

**NORME
INTERNATIONALE
INTERNATIONAL
STANDARD**

**CEI
IEC**

60950-1

Première édition
First edition
2001-10

**Matériels de traitement de l'information –
Sécurité –**

**Partie 1:
Prescriptions générales**

**Information technology equipment –
Safety –**

**Part 1:
General requirements**



Numéro de référence
Reference number
CEI/IEC 60950-1:2001

Numérotation des publications

Depuis le 1er janvier 1997, les publications de la CEI sont numérotées à partir de 60000. Ainsi, la CEI 34-1 devient la CEI 60034-1.

Editions consolidées

Les versions consolidées de certaines publications de la CEI incorporant les amendements sont disponibles. Par exemple, les numéros d'édition 1.0, 1.1 et 1.2 indiquent respectivement la publication de base, la publication de base incorporant l'amendement 1, et la publication de base incorporant les amendements 1 et 2.

Informations supplémentaires sur les publications de la CEI

Le contenu technique des publications de la CEI est constamment revu par la CEI afin qu'il reflète l'état actuel de la technique. Des renseignements relatifs à cette publication, y compris sa validité, sont disponibles dans le Catalogue des publications de la CEI (voir ci-dessous) en plus des nouvelles éditions, amendements et corrigenda. Des informations sur les sujets à l'étude et l'avancement des travaux entrepris par le comité d'études qui a élaboré cette publication, ainsi que la liste des publications parues, sont également disponibles par l'intermédiaire de:

- **Site web de la CEI (www.iec.ch)**
- **Catalogue des publications de la CEI**
Le catalogue en ligne sur le site web de la CEI (www.iec.ch/catlg-f.htm) vous permet de faire des recherches en utilisant de nombreux critères, comprenant des recherches textuelles, par comité d'études ou date de publication. Des informations en ligne sont également disponibles sur les nouvelles publications, les publications remplacées ou retirées, ainsi que sur les corrigenda.
- **IEC Just Published**
Ce résumé des dernières publications parues (www.iec.ch/JP.htm) est aussi disponible par courrier électronique. Veuillez prendre contact avec le Service client (voir ci-dessous) pour plus d'informations.
- **Service clients**
Si vous avez des questions au sujet de cette publication ou avez besoin de renseignements supplémentaires, prenez contact avec le Service clients:
Email: custserv@iec.ch
Tél: +41 22 919 02 11
Fax: +41 22 919 03 00

Publication numbering

As from 1 January 1997 all IEC publications are issued with a designation in the 60000 series. For example, IEC 34-1 is now referred to as IEC 60034-1.

Consolidated editions

The IEC is now publishing consolidated versions of its publications. For example, edition numbers 1.0, 1.1 and 1.2 refer, respectively, to the base publication, the base publication incorporating amendment 1 and the base publication incorporating amendments 1 and 2.

Further information on IEC publications

The technical content of IEC publications is kept under constant review by the IEC, thus ensuring that the content reflects current technology. Information relating to this publication, including its validity, is available in the IEC Catalogue of publications (see below) in addition to new editions, amendments and corrigenda. Information on the subjects under consideration and work in progress undertaken by the technical committee which has prepared this publication, as well as the list of publications issued, is also available from the following:

- **IEC Web Site (www.iec.ch)**
- **Catalogue of IEC publications**
The on-line catalogue on the IEC web site (www.iec.ch/catlg-e.htm) enables you to search by a variety of criteria including text searches, technical committees and date of publication. On-line information is also available on recently issued publications, withdrawn and replaced publications, as well as corrigenda.
- **IEC Just Published**
This summary of recently issued publications (www.iec.ch/JP.htm) is also available by email. Please contact the Customer Service Centre (see below) for further information.
- **Customer Service Centre**
If you have any questions regarding this publication or need further assistance, please contact the Customer Service Centre:
Email: custserv@iec.ch
Tel: +41 22 919 02 11
Fax: +41 22 919 03 00

CONTENTS

FOREWORD.....	27
INTRODUCTION.....	31
0 Principles of safety	31
0.1 General principles of safety	31
0.2 Hazards.....	33
0.2.1 Electric shock.....	33
0.2.2 Energy related hazards.....	37
0.2.3 Fire	39
0.2.4 Heat related hazards	39
0.2.5 Mechanical hazards.....	39
0.2.6 Radiation.....	41
0.2.7 Chemical hazards.....	41
0.3 Materials and components.....	41
1 General	43
1.1 Scope.....	43
1.1.1 Equipment covered by this standard	43
1.1.2 Additional requirements	45
1.1.3 Exclusions	47
1.2 Definitions	47
1.2.1 Equipment electrical ratings.....	51
1.2.2 Operating conditions.....	51
1.2.3 Equipment mobility	51
1.2.4 Classes of equipment – Protection against electric shock.....	53
1.2.5 Connection to the supply	53
1.2.6 Enclosures	55
1.2.7 Accessibility	55
1.2.8 Circuits and circuit characteristics	57
1.2.9 Insulation	61
1.2.10 Clearances and creepage distances	63
1.2.11 Components	63
1.2.12 Flammability	65
1.2.13 Miscellaneous.....	67
1.3 General requirements.....	71
1.3.1 Application of requirements	71
1.3.2 Equipment design and construction	71
1.3.3 Supply voltage.....	71
1.3.4 Constructions not specifically covered	71
1.3.5 Equivalent materials	73
1.3.6 Orientation during transport and use.....	73
1.3.7 Choice of criteria	73
1.3.8 Examples mentioned in the standard	73
1.3.9 Conductive liquids	73

1.4	General conditions for tests.....	73
1.4.1	Application of tests	73
1.4.2	Type tests	73
1.4.3	Test samples	73
1.4.4	Operating parameters for tests	75
1.4.5	Supply voltage for tests	75
1.4.6	Supply frequency for tests	77
1.4.7	Electrical measuring instruments	77
1.4.8	Normal operating voltages	77
1.4.9	Measurement of voltage to earth	79
1.4.10	Loading configuration of the EUT	79
1.4.11	Power from a telecommunication network.....	81
1.4.12	Temperature measurement conditions	81
1.4.13	Temperature measurement methods	81
1.4.14	Simulated faults and abnormal conditions.....	83
1.4.15	Compliance by inspection of relevant data.....	83
1.5	Components.....	83
1.5.1	General	83
1.5.2	Evaluation and testing of components	85
1.5.3	Thermal controls.....	85
1.5.4	Transformers.....	85
1.5.5	Interconnecting cables.....	85
1.5.6	Capacitors in primary circuits	85
1.5.7	Double insulation or reinforced insulation bridged by components.....	87
1.5.8	Components in equipment for IT power distribution systems.....	87
1.6	Power interface	89
1.6.1	AC power distribution systems.....	89
1.6.2	Input current.....	89
1.6.3	Voltage limit of hand-held equipment.....	89
1.6.4	Neutral conductor	89
1.7	Markings and instructions	91
1.7.1	Power rating	91
1.7.2	Safety instructions	95
1.7.3	Short duty cycles	97
1.7.4	Supply voltage adjustment.....	97
1.7.5	Power outlets on the equipment.....	97
1.7.6	Fuse identification	97
1.7.7	Wiring terminals	99
1.7.8	Controls and indicators	101
1.7.9	Isolation of multiple power sources	101
1.7.10	IT power distribution systems	103
1.7.11	Thermostats and other regulating devices	103
1.7.12	Language	103
1.7.13	Durability.....	103
1.7.14	Removable parts	103

1.7.15	Replaceable batteries.....	103
1.7.16	Operator access with a tool.....	105
1.7.17	Equipment for restricted access locations.....	105
2	Protection from hazards.....	107
2.1	Protection from electric shock and energy hazards.....	107
2.1.1	Protection in operator access areas.....	107
2.1.2	Protection in service access areas.....	119
2.1.3	Protection in restricted access locations.....	119
2.2	SELV circuits.....	121
2.2.1	General requirements.....	121
2.2.2	Voltages under normal conditions.....	121
2.2.3	Voltages under fault conditions.....	121
2.2.4	Connection of SELV circuits to other circuits.....	123
2.3	TNV circuits.....	125
2.3.1	Limits.....	125
2.3.2	Separation from other circuits and from accessible parts.....	127
2.3.3	Separation from hazardous voltages.....	129
2.3.4	Connection of TNV circuits to other circuits.....	129
2.3.5	Test for operating voltages generated externally.....	131
2.4	Limited current circuits.....	133
2.4.1	General requirements.....	133
2.4.2	Limit values.....	133
2.4.3	Connection of limited current circuits to other circuits.....	135
2.5	Limited power sources.....	135
2.6	Provisions for earthing and bonding.....	139
2.6.1	Protective earthing.....	139
2.6.2	Functional earthing.....	139
2.6.3	Protective earthing and protective bonding conductors.....	141
2.6.4	Terminals.....	147
2.6.5	Integrity of protective earthing.....	149
2.7	Overcurrent and earth fault protection in primary circuits.....	153
2.7.1	Basic requirements.....	153
2.7.2	Faults not covered in 5.3.....	153
2.7.3	Short-circuit backup protection.....	153
2.7.4	Number and location of protective devices.....	155
2.7.5	Protection by several devices.....	157
2.7.6	Warning to service persons.....	157
2.8	Safety interlocks.....	159
2.8.1	General principles.....	159
2.8.2	Protection requirements.....	159
2.8.3	Inadvertent reactivation.....	159
2.8.4	Fail-safe operation.....	161
2.8.5	Moving parts.....	161
2.8.6	Overriding.....	161
2.8.7	Switches and relays.....	163
2.8.8	Mechanical actuators.....	165

2.9	Electrical insulation	165
2.9.1	Properties of insulating materials.....	165
2.9.2	Humidity conditioning	165
2.9.3	Grade of insulation	167
2.10	Clearances, creepage distances and distances through insulation.....	173
2.10.1	General	173
2.10.2	Determination of working voltage.....	175
2.10.3	Clearances	177
2.10.4	Creepage distances.....	191
2.10.5	Solid insulation.....	195
2.10.6	Coated printed boards	201
2.10.7	Enclosed and sealed parts	209
2.10.8	Spacings filled by insulating compound	209
2.10.9	Component external terminations	211
2.10.10	Insulation with varying dimensions.....	211
3	Wiring, connections and supply.....	213
3.1	General	213
3.1.1	Current rating and overcurrent protection	213
3.1.2	Protection against mechanical damage.....	213
3.1.3	Securing of internal wiring	213
3.1.4	Insulation of conductors.....	215
3.1.5	Beads and ceramic insulators.....	215
3.1.6	Screws for electrical contact pressure	215
3.1.7	Insulating materials in electrical connections	217
3.1.8	Self-tapping and spaced thread screws	217
3.1.9	Termination of conductors	217
3.1.10	Sleeving on wiring	219
3.2	Connection to an a.c. mains supply or a d.c. mains supply	219
3.2.1	Means of connection	219
3.2.2	Multiple supply connections.....	221
3.2.3	Permanently connected equipment.....	221
3.2.4	Appliance inlets.....	223
3.2.5	Power supply cords	225
3.2.6	Cord anchorages and strain relief.....	227
3.2.7	Protection against mechanical damage.....	231
3.2.8	Cord guards	231
3.2.9	Supply wiring space.....	233
3.3	Wiring terminals for connection of external conductors	233
3.3.1	Wiring terminals	233
3.3.2	Connection of non-detachable power supply cords	233
3.3.3	Screw terminals.....	233
3.3.4	Conductor sizes to be connected.....	235
3.3.5	Wiring terminal sizes	235
3.3.6	Wiring terminal design.....	237
3.3.7	Grouping of wiring terminals	237
3.3.8	Stranded wire	237

3.4	Disconnection from the mains supply.....	239
3.4.1	General requirement.....	239
3.4.2	Disconnect devices.....	239
3.4.3	Permanently connected equipment.....	241
3.4.4	Parts which remain energized.....	241
3.4.5	Switches in flexible cords.....	241
3.4.6	Single-phase and d.c. equipment.....	241
3.4.7	Three-phase equipment.....	241
3.4.8	Switches as disconnect devices.....	243
3.4.9	Plugs as disconnect devices.....	243
3.4.10	Interconnected equipment.....	243
3.4.11	Multiple power sources.....	243
3.5	Interconnection of equipment.....	243
3.5.1	General requirements.....	243
3.5.2	Types of interconnection circuits.....	245
3.5.3	ELV circuits as interconnection circuits.....	245
4	Physical requirements.....	247
4.1	Stability.....	247
4.2	Mechanical strength.....	247
4.2.1	General.....	247
4.2.2	Steady force test, 10 N.....	249
4.2.3	Steady force test, 30 N.....	249
4.2.4	Steady force test, 250 N.....	251
4.2.5	Impact test.....	251
4.2.6	Drop test.....	253
4.2.7	Stress relief test.....	253
4.2.8	Cathode ray tubes.....	255
4.2.9	High pressure lamps.....	255
4.2.10	Wall or ceiling mounted equipment.....	255
4.3	Design and construction.....	255
4.3.1	Edges and corners.....	255
4.3.2	Handles and manual controls.....	255
4.3.3	Adjustable controls.....	257
4.3.4	Securing of parts.....	257
4.3.5	Connection of plugs and sockets.....	257
4.3.6	Direct plug-in equipment.....	259
4.3.7	Heating elements in earthed equipment.....	259
4.3.8	Batteries.....	259
4.3.9	Oil and grease.....	261
4.3.10	Dust, powders, liquids and gases.....	263
4.3.11	Containers for liquids or gases.....	263
4.3.12	Flammable liquids.....	263
4.3.13	Radiation.....	265
4.4	Protection against hazardous moving parts.....	273
4.4.1	General.....	273
4.4.2	Protection in operator access areas.....	273
4.4.3	Protection in restricted access locations.....	275
4.4.4	Protection in service access areas.....	275

4.5	Thermal requirements	275
4.5.1	Maximum temperatures	275
4.5.2	Resistance to abnormal heat	279
4.6	Openings in enclosures	281
4.6.1	Top and side openings	281
4.6.2	Bottoms of fire enclosures	287
4.6.3	Doors or covers in fire enclosures	291
4.6.4	Openings in transportable equipment	291
4.6.5	Adhesives for constructional purposes.....	293
4.7	Resistance to fire	293
4.7.1	Reducing the risk of ignition and spread of flame.....	295
4.7.2	Conditions for a fire enclosure	295
4.7.3	Materials	297
5	Electrical requirements and simulated abnormal conditions	311
5.1	Touch current and protective conductor current.....	311
5.1.1	General	311
5.1.2	Equipment under test (EUT)	311
5.1.3	Test circuit	311
5.1.4	Application of measuring instrument.....	315
5.1.5	Test procedure	317
5.1.6	Test measurements	317
5.1.7	Equipment with touch current exceeding 3,5 mA.....	319
5.1.8	Touch currents to telecommunication networks and cable distribution systems and from telecommunication networks	321
5.2	Electric strength	325
5.2.1	General	325
5.2.2	Test procedure	325
5.3	Abnormal operating and fault conditions.....	333
5.3.1	Protection against overload and abnormal operation.....	333
5.3.2	Motors.....	333
5.3.3	Transformers.....	333
5.3.4	Functional insulation.....	335
5.3.5	Electromechanical components	335
5.3.6	Simulation of faults	335
5.3.7	Unattended equipment	337
5.3.8	Compliance criteria for abnormal operating and fault conditions	339
6	Connection to telecommunication networks	341
6.1	Protection of telecommunication network service persons, and users of other equipment connected to the network, from hazards in the equipment	341
6.1.1	Protection from hazardous voltages.....	341
6.1.2	Separation of the telecommunication network from earth	341
6.2	Protection of equipment users from overvoltages on telecommunication networks.....	343
6.2.1	Separation requirements	343
6.2.2	Electric strength test procedure	345

6.3	Protection of the telecommunication wiring system from overheating.....	349
7	Connection to cable distribution systems	353
7.1	Protection of cable distribution system service persons, and users of other equipment connected to the system, from hazardous voltages in the equipment.....	353
7.2	Protection of equipment users from overvoltages on the cable distribution system	353
7.3	Insulation between primary circuits and cable distribution systems.....	355
7.3.1	General	355
7.3.2	Voltage surge test	355
7.3.3	Impulse test.....	357
Annex A (normative) Tests for resistance to heat and fire		359
A.1	Flammability test for fire enclosures of movable equipment having a total mass exceeding 18 kg and of stationary equipment (see 4.7.3.2).....	359
A.1.1	Samples	359
A.1.2	Conditioning of samples	359
A.1.3	Mounting of samples	359
A.1.4	Test flame	359
A.1.5	Test procedure	359
A.1.6	Compliance criteria	361
A.2	Flammability test for fire enclosures of movable equipment having a total mass not exceeding 18 kg, and for material and components located inside fire enclosures (see 4.7.3.2 and 4.7.3.4).....	361
A.2.1	Samples	361
A.2.2	Conditioning of samples	361
A.2.3	Mounting of samples	361
A.2.4	Test flame	361
A.2.5	Test procedure	361
A.2.6	Compliance criteria	363
A.2.7	Alternative test	363
A.3	Hot flaming oil test (see 4.6.2)	363
A.3.1	Mounting of samples	363
A.3.2	Test procedure	363
A.3.3	Compliance criterion.....	363
Annex B (normative) Motor tests under abnormal conditions (see 4.7.2.2 and 5.3.2).....		365
B.1	General requirements	365
B.2	Test conditions	365
B.3	Maximum temperatures.....	367
B.4	Running overload test.....	369
B.5	Locked-rotor overload test	369
B.6	Running overload test for d.c. motors in secondary circuits.....	371

B.7	Locked-rotor overload test for d.c. motors in secondary circuits	373
B.7.1	Test procedure	373
B.7.2	Alternative test procedure.....	373
B.7.3	Electric strength test.....	373
B.8	Test for motors with capacitors	373
B.9	Test for three-phase motors.....	375
B.10	Test for series motors	375
Annex C (normative)	Transformers (see 1.5.4 and 5.3.3).....	377
C.1	Overload test.....	377
C.2	Insulation.....	379
Annex D (normative)	Measuring instruments for touch-current tests (see 5.1.4).....	383
D.1	Measuring instrument	383
D.2	Alternative measuring instrument.....	385
Annex E (normative)	Temperature rise of a winding (see 1.4.13)	387
Annex F (normative)	Measurement of clearances and creepage distances (see 2.10).....	389
Annex G (normative)	Alternative method for determining minimum clearances.....	403
G.1	Summary of the procedure for determining minimum clearances.....	403
G.2	Determination of mains transient voltage	403
G.2.1	AC mains supply	403
G.2.2	DC mains supply	405
G.3	Determination of telecommunication network transient voltage	407
G.4	Determination of required withstand voltage	407
G.5	Measurement of transient voltage levels	409
G.6	Determination of minimum clearances	411
Annex H (normative)	Ionizing radiation (see 4.3.13).....	417
Annex J (normative)	Table of electrochemical potentials (see 2.6.5.6).....	419
Annex K (normative)	Thermal controls (see 1.5.3 and 5.3.7).....	421
K.1	Making and breaking capacity.....	421
K.2	Thermostat reliability	421
K.3	Thermostat endurance test	421
K.4	Temperature limiter endurance	423
K.5	Thermal cut-out reliability.....	423
K.6	Stability of operation	423

Annex L (normative) Normal load conditions for some types of electrical business equipment (see 1.2.2.1 and 4.5.1).....	425
L.1 Typewriters.....	425
L.2 Adding machines and cash registers.....	425
L.3 Erasers.....	425
L.4 Pencil sharpeners.....	425
L.5 Duplicators and copy machines.....	425
L.6 Motor-operated files.....	427
L.7 Other business equipment.....	427
Annex M (normative) Criteria for telephone ringing signals (see 2.3.1).....	429
M.1 Introduction.....	429
M.2 Method A.....	429
M.3 Method B.....	435
M.3.1 Ringing signal.....	435
M.3.2 Tripping device and monitoring voltage.....	435
Annex N (normative) Impulse test generators (see 2.10.3.4, 6.2.2.1, 7.3.2 and clause G.5).....	439
N.1 ITU-T impulse test generators.....	439
N.2 IEC 60065 impulse test generator.....	441
Annex P (normative) Normative references.....	443
Annex Q (informative) Bibliography.....	449
Annex R (informative) Examples of requirements for quality control programmes.....	451
R.1 Minimum separation distances for unpopulated coated printed boards (see 2.10.6).....	451
R.2 Reduced clearances (see 2.10.3).....	453
Annex S (informative) Procedure for impulse testing (see 6.2.2.3).....	457
S.1 Test equipment.....	457
S.2 Test procedure.....	457
S.3 Examples of waveforms during impulse testing.....	457
Annex T (informative) Guidance on protection against ingress of water (see 1.1.2).....	461
Annex U (normative) Insulated winding wires for use without interleaved insulation (see 2.10.5.4).....	465
U.1 Wire construction.....	465
U.2 Type tests.....	465
U.2.1 Electric strength.....	465
U.2.2 Flexibility and adherence.....	465
U.2.3 Heat shock.....	467
U.2.4 Retention of electric strength after bending.....	467

U.3	Tests during manufacture	469
U.3.1	Routine testing	469
U.3.2	Sampling tests.....	469
Annex V (normative)	AC power distribution systems (see 1.6.1)	471
V.1	Introduction	471
V.2	TN power distribution systems	473
V.3	TT power distribution systems	479
V.4	IT power distribution systems.....	481
Annex W (informative)	Summation of touch currents.....	485
W.1	Touch current from electronic circuits	485
W.1.1	Floating circuits	485
W.1.2	Earthed circuits	487
W.2	Interconnection of several equipments.....	487
W.2.1	Isolation	489
W.2.2	Common return, isolated from earth	489
W.2.3	Common return, connected to protective earth	489
Annex X (informative)	Maximum heating effect in transformer tests (see clause C.1).....	491
X.1	Determination of maximum input current.....	491
X.2	Overload test procedure	493
Annex Y (normative)	Ultraviolet light conditioning test (see 4.3.13.3).....	495
Y.1	Test apparatus.....	495
Y.2	Mounting of test samples	495
Y.3	Carbon-arc light-exposure apparatus	495
Y.4	Xenon-arc light-exposure apparatus	495
Figure 2A	– Test finger.....	111
Figure 2B	– Test pin.....	113
Figure 2C	– Test probe.....	113
Figure 2D	– Maximum voltages permitted after a single fault	125
Figure 2E	– Test generator.....	133
Figure 2F	– Examples of application of insulation.....	173
Figure 2G	– Thermal ageing time.....	205
Figure 2H	– Abrasion resistance test for coating layers	207
Figure 4A	– Impact test using a steel ball	251
Figure 4B	– Examples of cross-sections of designs of openings preventing vertical access	283
Figure 4C	– Examples of louvre design.....	283
Figure 4D	– Enclosure openings.....	285
Figure 4E	– Typical bottom of a fire enclosure for partially enclosed component or assembly.....	287
Figure 4F	– Baffle plate construction.....	289
Figure 5A	– Test circuit for touch current of single-phase equipment on a star TN or TT power supply system	313

Figure 5B – Test circuit for touch current of three-phase equipment on a star TN or TT power supply system	315
Figure 6A – Test for separation between a telecommunication network and earth	343
Figure 6B – Application points of test voltage	347
Figure B.1 – Determination of arithmetic average temperature	367
Figure C.1 – Determination of arithmetic average temperature	379
Figure D.1 – Measuring instrument	383
Figure D.2 – Alternative measuring instrument	385
Figure F.1 – Narrow groove	389
Figure F.2 – Wide groove	391
Figure F.3 – V-shaped groove	391
Figure F.4 – Rib	391
Figure F.5 – Uncemented joint with narrow groove	393
Figure F.6 – Uncemented joint with wide groove	393
Figure F.7 – Uncemented joint with narrow and wide grooves	393
Figure F.8 – Narrow recess	395
Figure F.9 – Wide recess	395
Figure F.10 – Coating around terminals	397
Figure F.11 – Coating over printed wiring	397
Figure F.12 – Example of measurements in an enclosure of insulating material	399
Figure F.13 – Intervening, unconnected conductive part	401
Figure M.1 – Definition of ringing period and cadence cycle	431
Figure M.2 – I_{TS1} limit curve for cadenced ringing signal	433
Figure M.3 – Peak and peak-to-peak currents	433
Figure M.4 – Ringing voltage trip criteria	437
Figure N.1 – ITU-T impulse test generator circuit	439
Figure N.2 – IEC 60065 impulse test generator circuit	441
Figure S.1 – Waveform on insulation without surge suppressors and no breakdown	457
Figure S.2 – Waveforms on insulation during breakdown without surge suppressors	459
Figure S.3 – Waveforms on insulation with surge suppressors in operation	459
Figure S.4 – Waveform on short-circuited surge suppressor and insulation	459
Figure V.1 – Examples of TN-S power distribution systems	475
Figure V.2 – Example of TN-C-S power distribution system	477
Figure V.3 – Example of TN-C power distribution system	477
Figure V.4 – Example of single-phase, 3-wire TN-C power distribution system	479
Figure V.5 – Example of three line and neutral TT power distribution system	479
Figure V.6 – Example of three line TT power distribution system	481
Figure V.7 – Example of three line (and neutral) IT power distribution system	481
Figure V.8 – Example of three line IT power distribution system	483
Figure W.1 – Touch current from a floating circuit	485
Figure W.2 – Touch current from an earthed circuit	487
Figure W.3 – Summation of touch currents in a PABX	487
Table 1A – Voltage ranges of SELV and TNV circuits	61
Table 2A – Distance through insulation of internal wiring	115
Table 2B – Limits for inherently limited power sources	137

Table 2C – Limits for power sources not inherently limited (overcurrent protective device required).....	137
Table 2D – Minimum size of protective bonding conductors	143
Table 2E – Informative examples of protective devices in single-phase equipment or subassemblies.....	155
Table 2F – Informative examples of protective devices in three-phase equipment	157
Table 2G – Examples of application of insulation	169
Table 2H – Minimum clearances for insulation in primary circuits and between primary and secondary circuits.....	183
Table 2J – Additional clearances for insulation in primary circuits with peak working voltages exceeding the peak value of the nominal a.c. mains supply voltage	185
Table 2K – Minimum clearances in secondary circuits	189
Table 2L – Minimum creepage distances.....	195
Table 2M – Insulation in printed boards.....	199
Table 2N – Minimum separation distances for coated printed boards.....	203
Table 3A – Sizes of cables and conduits for equipment having a rated current not exceeding 16 A.....	223
Table 3B – Sizes of conductors	227
Table 3C – Physical tests on power supply cords.....	229
Table 3D – Range of conductor sizes to be accepted by terminals.....	235
Table 3E – Sizes of terminals for mains supply conductors and protective earthing conductors	235
Table 4A – Minimum property retention limits after UV exposure	267
Table 4B – Temperature limits Part 1	277
Table 4B – Temperature limits Part 2	279
Table 4C – Size and spacing of openings in metal bottoms of fire enclosures.....	289
Table 4D – Summary of material flammability requirements	309
Table 5A – Maximum current.....	319
Table 5B – Test voltages for electric strength tests Part 1	329
Table 5B – Test voltages for electric strength tests Part 2	331
Table B.1 – Permitted temperature limits for motor windings (except for running overload test).....	367
Table B.2 – Permitted temperature limits for running overload tests	369
Table C.1 – Permitted temperature limits for transformer windings	379
Table F.1 – Value of X	389
Table G.1 – Mains transient voltages.....	405
Table G.2 – Minimum clearances up to 2 000 m above sea level	413
Table J.1 – Electrochemical potentials (V)	419
Table N.1 – Component values for figures N.1 and N.2	441
Table R.1 – Rules for sampling and inspection – coated printed boards	453
Table R.2 – Rules for sampling and inspection – reduced clearances.....	455
Table T.1 – Extract from IEC 60529:1989.....	463
Table U.1 – Mandrel diameter	467
Table U.2 – Oven temperature	467
Table X.1 – Test steps	493

INTERNATIONAL ELECTROTECHNICAL COMMISSION

INFORMATION TECHNOLOGY EQUIPMENT – SAFETY –

Part 1: General requirements

FOREWORD

- 1) The IEC (International Electrotechnical Commission) is a worldwide organization for standardization comprising all national electrotechnical committees (IEC National Committees). The object of the IEC is to promote international co-operation on all questions concerning standardization in the electrical and electronic fields. To this end and in addition to other activities, the IEC publishes International Standards. Their preparation is entrusted to technical committees; any IEC National Committee interested in the subject dealt with may participate in this preparatory work. International, governmental and non-governmental organizations liaising with the IEC also participate in this preparation. The IEC collaborates closely with the International Organization for Standardization (ISO) in accordance with conditions determined by agreement between the two organizations.
- 2) The formal decisions or agreements of the IEC on technical matters express, as nearly as possible, an international consensus of opinion on the relevant subjects since each technical committee has representation from all interested National Committees.
- 3) The documents produced have the form of recommendations for international use and are published in the form of standards, technical specifications, technical reports or guides and they are accepted by the National Committees in that sense.
- 4) In order to promote international unification, IEC National Committees undertake to apply IEC International Standards transparently to the maximum extent possible in their national and regional standards. Any divergence between the IEC Standard and the corresponding national or regional standard shall be clearly indicated in the latter.
- 5) The IEC provides no marking procedure to indicate its approval and cannot be rendered responsible for any equipment declared to be in conformity with one of its standards.
- 6) Attention is drawn to the possibility that some of the elements of this International Standard may be the subject of patent rights. The IEC shall not be held responsible for identifying any or all such patent rights.

International Standard IEC 60950-1 has been prepared by IEC technical committee 74: Safety and energy efficiency of IT equipment.

This first edition of IEC 60950-1 cancels and replaces the third edition of IEC 60950, issued in 1999, and constitutes a technical revision.

The text of this standard is based on the following documents:

FDIS	Report on voting
74/590/FDIS	74/596/RVD

Full information on the voting for the approval of this standard can be found in the report on voting indicated in the above table.

The committee has decided that the contents of this publication will remain unchanged until 2004-11. At this date, the publication will be

- reconfirmed,
- withdrawn,
- replaced by a revised edition, or
- amended.

IEC 60950-1 includes the basic requirements for the safety of Information Technology equipment.

Additional parts cover specific safety requirements for Information Technology equipment having limited applications or having special features as follows:

Part 21: Remote feeding.

Annexes A, B, C, D, E, F, G, H, J, K, L, M, N, P, U, V and Y form an integral part of this standard.

Annexes Q, R, S, T, W and X are for information only.

In this standard, the following print types are used:

- Requirements proper and normative annexes: in roman type.
- *Compliance statements and test specifications: in italic type.*
- Notes and other informative matter: in smaller roman type.
- Normative conditions within tables: in smaller roman type.
- Terms that are defined in 1.2: SMALL CAPITALS.

INTRODUCTION

0 Principles of safety

The following principles have been adopted by technical committee 74 in the development of this standard.

These principles do not cover performance or functional characteristics of equipment.

Words printed in SMALL CAPITALS are terms that are defined in 1.2 of this standard.

0.1 General principles of safety

It is essential that designers understand the underlying principles of safety requirements in order that they can engineer safe equipment.

These principles are not an alternative to the detailed requirements of this standard, but are intended to provide designers with an appreciation of the basis of these requirements. Where the equipment involves technologies and materials or methods of construction not specifically covered, the design of the equipment should provide a level of safety not less than those described in these principles of safety.

Designers shall take into account not only normal operating conditions of the equipment but also likely fault conditions, consequential faults, foreseeable misuse and external influences such as temperature, altitude, pollution, moisture, overvoltages on the mains and overvoltages on a TELECOMMUNICATION NETWORK or a CABLE DISTRIBUTION SYSTEM.

The following priorities should be observed in determining what design measures to adopt:

- where possible, specify design criteria that will eliminate, reduce or guard against hazards;
- where the above is not practicable because the functioning of the equipment would be impaired, specify the use of protective means independent of the equipment, such as personal protective equipment (which is not specified in this standard);
- where neither of the above measures is practicable, or in addition to those measures, specify the provision of markings and instructions regarding the residual risks.

There are two types of persons whose safety needs to be considered, USERS (or OPERATORS) and SERVICE PERSONS.

USER is the term applied to all persons other than SERVICE PERSONS. Requirements for protection should assume that USERS are not trained to identify hazards, but will not intentionally create a hazardous situation. Consequently, the requirements will provide protection for cleaners and casual visitors as well as the assigned USERS. In general, USERS should not have access to hazardous parts, and to this end, such parts should only be in SERVICE ACCESS AREAS or in equipment located in RESTRICTED ACCESS LOCATIONS.

When USERS are admitted to RESTRICTED ACCESS LOCATIONS they shall be suitably instructed.

SERVICE PERSONS are expected to use their training and skill to avoid possible injury to themselves and others due to obvious hazards which exist in SERVICE ACCESS AREAS of the equipment or on equipment located in RESTRICTED ACCESS LOCATIONS. However, SERVICE PERSONS should be protected against unexpected hazards. This can be done by, for example, locating parts that need to be accessible for servicing away from electrical and mechanical hazards, providing shields to avoid accidental contact with hazardous parts, and providing labels or instructions to warn personnel about any residual risk.

Information about potential hazards can be marked on the equipment or provided with the equipment, depending on the likelihood and severity of injury, or made available for SERVICE PERSONS. In general, USERS shall not be exposed to hazards likely to cause injury, and information provided for USERS should primarily aim at avoiding misuse and situations likely to create hazards, such as connection to the wrong power source and replacement of fuses by incorrect types.

MOVABLE EQUIPMENT is considered to present a slightly increased risk of shock, due to possible extra strain on the supply cord leading to rupture of the earthing conductor. With HAND-HELD EQUIPMENT, this risk is increased; wear on the cord is more likely, and further hazards could arise if the units were dropped. TRANSPORTABLE EQUIPMENT introduces a further factor because it can be used and carried in any orientation; if a small metallic object enters an opening in the ENCLOSURE it can move around inside the equipment, possibly creating a hazard.

0.2 Hazards

Application of a safety standard is intended to reduce the risk of injury or damage due to the following:

- electric shock;
- energy related hazards;
- fire;
- heat related hazards;
- mechanical hazards;
- radiation;
- chemical hazards.

0.2.1 Electric shock

Electric shock is due to current passing through the human body. The resulting physiological effects depend on the value and duration of the current and the path it takes through the body. The value of the current depends on the applied voltage, the impedance of the source and the impedance of the body. The body impedance depends in turn on the area of contact, moisture in the area of contact and the applied voltage and frequency. Currents of approximately half a milliampere can cause a reaction in persons in good health and may cause injury indirectly due to involuntary reaction. Higher currents can have more direct effects, such as burn, muscle tetanization or ventricular fibrillation.

Steady state voltages up to 42,4 V peak, or 60 V d.c., are not generally regarded as hazardous under dry conditions for an area of contact equivalent to a human hand. Bare parts which have to be touched or handled should be at earth potential or properly insulated.

Some equipment will be connected to telephone and other external networks. Some TELECOMMUNICATION NETWORKS operate with signals such as voice and ringing superimposed on a steady DC VOLTAGE; the total may exceed the values given above for steady-state voltages. It is common practice for the SERVICE PERSONS of telephone companies to handle parts of such circuits bare-handed. This has not caused serious injury, because of the use of cadenced ringing and because there are limited areas of contact with bare conductors normally handled by SERVICE PERSONS. However, the area of contact of a part accessible to the USER, and the likelihood of the part being touched, should be further limited (for example, by the shape and location of the part).

It is normal to provide two levels of protection for USERS to prevent electric shock. Therefore, the operation of equipment under normal conditions and after a single fault, including any consequential faults, should not create a shock hazard. However, provision of additional protective measures, such as protective earthing or SUPPLEMENTARY INSULATION, is not considered a substitute for, or a relief from, properly designed BASIC INSULATION.

Harm may result from:

Contact with bare parts normally at HAZARDOUS VOLTAGES.

Breakdown of insulation between parts normally at HAZARDOUS VOLTAGES and accessible conductive parts.

Contact with circuits connected to TELE-COMMUNICATION NETWORKS which exceed 42,4 V peak or 60 V d.c.

Breakdown of USER-accessible insulation.

TOUCH CURRENT (leakage current) flowing from parts at HAZARDOUS VOLTAGES to accessible parts, or failure of a protective earthing connection. TOUCH CURRENT may include current due to EMC filter components connected between PRIMARY CIRCUITS and accessible parts.

Examples of measures to reduce risks:

Prevent USER access to parts at HAZARDOUS VOLTAGES by fixed or locked covers, SAFETY INTERLOCKS, etc. Discharge accessible capacitors that are at HAZARDOUS VOLTAGES.

Provide BASIC INSULATION and connect the accessible conductive parts and circuits to earth so that exposure to the voltage which can develop is limited because overcurrent protection will disconnect the parts having low impedance faults within a specified time; or provide a metal screen connected to protective earth between the parts, or provide DOUBLE INSULATION or REINFORCED INSULATION between the parts, so that breakdown to the accessible part is not likely to occur.

Limit the accessibility and area of contact of such circuits, and separate them from unearthed parts to which access is not limited.

Insulation which is accessible to the USER should have adequate mechanical and electrical strength to reduce the likelihood of contact with HAZARDOUS VOLTAGES.

Limit TOUCH CURRENT to a specified value, or provide a high integrity protective earthing connection.

0.2.2 Energy related hazards

Injury or fire may result from a short circuit between adjacent poles of high current supplies or high capacitance circuits, causing:

- burns;
- arcing;
- ejection of molten metal.

Even circuits whose voltages are safe to touch may be hazardous in this respect.

Examples of measures to reduce risks include:

- separation;
- shielding;
- provision of SAFETY INTERLOCKS.

0.2.3 Fire

Risk of fire may result from excessive temperatures either under normal operating conditions or due to overload, component failure, insulation breakdown or loose connections. Fires originating within the equipment should not spread beyond the immediate vicinity of the source of the fire, nor cause damage to the surroundings of the equipment.

Examples of measures to reduce risks include:

- providing overcurrent protection;
- using constructional materials having appropriate flammability properties for their purpose;
- selection of parts, components and consumable materials to avoid high temperature which might cause ignition;
- limiting the quantity of combustible materials used;
- shielding or separating combustible materials from likely ignition sources;
- using ENCLOSURES or barriers to limit the spread of fire within the equipment;
- using suitable materials for ENCLOSURES so as to reduce the likelihood of fire spreading from the equipment.

0.2.4 Heat related hazards

Injury may result from high temperatures under normal operating conditions, causing:

- burns due to contact with hot accessible parts;
- degradation of insulation and of safety-critical components;
- ignition of flammable liquids.

Examples of measures to reduce risks include:

- taking steps to avoid high temperature of accessible parts;
- avoiding temperatures above the ignition point of liquids;
- provision of markings to warn USERS where access to hot parts is unavoidable.

0.2.5 Mechanical hazards

Injury may result from:

- sharp edges and corners;
- moving parts which have the potential to cause injury;
- equipment instability;
- flying particles from imploding cathode ray tubes and exploding high pressure lamps.

Examples of measures to reduce risks include:

- rounding of sharp edges and corners;
- guarding;
- provision of SAFETY INTERLOCKS;
- providing sufficient stability to free-standing equipment;
- selecting cathode ray tubes and high pressure lamps that are resistant to implosion and explosion respectively;
- provision of markings to warn USERS where access is unavoidable.

0.2.6 Radiation

Injury to USERS and to SERVICE PERSONS may result from some forms of radiation emitted by equipment. Examples are sonic (acoustic), radio frequency, infra-red, ultraviolet and ionizing radiation, and high intensity visible and coherent light (lasers).

Examples of measures to reduce risks include:

- limiting the energy level of potential radiation sources;
- screening radiation sources;
- provision of SAFETY INTERLOCKS;
- provision of markings to warn USERS where exposure to the radiation hazard is unavoidable.

0.2.7 Chemical hazards

Injury may result from contact with some chemicals or from inhalation of their vapours and fumes.

Examples of measures to reduce risks include:

- avoiding the use of constructional and consumable materials likely to cause injury by contact or inhalation during intended and normal conditions of use;
- avoiding conditions likely to cause leakage or vaporization;
- provision of markings to warn USERS about the hazards.

0.3 Materials and components

Materials and components used in the construction of equipment should be so selected and arranged that they can be expected to perform in a reliable manner for the anticipated life of the equipment without creating a hazard, and would not contribute significantly to the development of a serious fire hazard. Components should be selected so that they remain within their manufacturers' ratings under normal operating conditions, and do not create a hazard under fault conditions.

INFORMATION TECHNOLOGY EQUIPMENT – SAFETY –

Part 1: General requirements

1 General

1.1 Scope

1.1.1 Equipment covered by this standard

This standard is applicable to mains-powered or battery-powered information technology equipment, including electrical business equipment and associated equipment, with a RATED VOLTAGE not exceeding 600 V.

This standard is also applicable to such information technology equipment:

- designed for use as telecommunication terminal equipment and TELECOMMUNICATION NETWORK infrastructure equipment, regardless of the source of power;
- designed and intended to be connected directly to, or used as infrastructure equipment in, a CABLE DISTRIBUTION SYSTEM, regardless of the source of power;
- designed to use the AC MAINS SUPPLY as a communication transmission medium (see note 4 of clause 6 and note 3 of clause 7).

This standard specifies requirements intended to reduce risks of fire, electric shock or injury for the OPERATOR and layman who may come into contact with the equipment and, where specifically stated, for a SERVICE PERSON.

This standard is intended to reduce such risks with respect to installed equipment, whether it consists of a system of interconnected units or independent units, subject to installing, operating and maintaining the equipment in the manner prescribed by the manufacturer.

Examples of equipment which is in the scope of this standard are:

Generic product type	Specific example of generic type
banking equipment	monetary processing machines including automated teller (cash dispensing) machines (ATM)
data and text processing machines and associated equipment	data preparation equipment, data processing equipment, data storage equipment, personal computers, plotters, printers, scanners, text processing equipment, visual display units
data network equipment	bridges, data circuit terminating equipment, data terminal equipment, routers
electrical and electronic retail equipment	cash registers, point of sale terminals including associated electronic scales
electrical and electronic office machines	calculators, copying machines, dictation equipment, document shredding machines, duplicators, erasers, micrographic office equipment, motor-operated files, paper trimmers (punchers, cutting machines, separators), paper jogging machines, pencil sharpeners, staplers, typewriters
other IT equipment	photoprinting equipment, public information terminals, multimedia equipment
postage equipment	mail processing machines, postage machines
telecommunication network infrastructure equipment	billing equipment, multiplexers, network powering equipment, network terminating equipment, radio basestations, repeaters, transmission equipment, telecommunication switching equipment
telecommunication terminal equipment	facsimile equipment, key telephone systems, modems, PABX's, pagers, telephone answering machines, telephone sets (wired and wireless)

NOTE The requirements of IEC 60065 may also be used to meet safety requirements for multimedia equipment. See IEC Guide 112, Guide on the safety of multimedia equipment ¹⁾.

This list is not intended to be comprehensive, and equipment that is not listed is not necessarily excluded from the scope.

Equipment complying with the relevant requirements in this standard is considered suitable for use with process control equipment, automatic test equipment and similar systems requiring information processing facilities. However, this standard does not include requirements for performance or functional characteristics of equipment.

1.1.2 Additional requirements

Requirements additional to those specified in this standard may be necessary for:

- equipment intended for operation in special environments (for example, extremes of temperature; excessive dust, moisture or vibration; flammable gases; and corrosive or explosive atmospheres);
- electromedical applications with physical connections to the patient;
- equipment intended to be used in vehicles, on board ships or aircraft, in tropical countries, or at altitudes greater than 2 000 m;
- equipment intended for use where ingress of water is possible; for guidance on such requirements and on relevant testing, see annex T.

NOTE Attention is drawn to the fact that authorities of some countries impose additional requirements.

¹⁾ A list of informative references is given in annex Q: "Bibliography".

1.1.3 Exclusions

This standard does not apply to:

- support equipment, such as air conditioning, fire detection or fire extinguishing systems;
- power supply systems which are not an integral part of the equipment, such as motor-generator sets, battery backup systems and transformers;
- building installation wiring;
- devices requiring no electric power.

1.2 Definitions

For the purpose of this International Standard the following definitions apply. Where the terms "voltage" and "current" are used they imply the r.m.s. values, unless otherwise specified.

Definitions in alphabetical order of nouns

Area, operator access	1.2.7.1
Area, service access	1.2.7.2
Body	1.2.7.5
Cable, interconnecting	1.2.11.6
Cable distribution system	1.2.13.14
Circuit, ELV	1.2.8.6
Circuit, limited current	1.2.8.8
Circuit, primary	1.2.8.3
Circuit, secondary	1.2.8.4
Circuit, SELV	1.2.8.7
Circuit, TNV	1.2.8.10
Circuit, TNV-1	1.2.8.11
Circuit, TNV-2	1.2.8.12
Circuit, TNV-3	1.2.8.13
Clearance	1.2.10.1
Conductor, protective bonding	1.2.13.11
Conductor, protective earthing	1.2.13.10
Cord, detachable power supply	1.2.5.4
Cord, non-detachable power supply	1.2.5.5
Creepage distance	1.2.10.2
Current, protective conductor	1.2.13.13
Current, rated	1.2.1.3
Current, touch	1.2.13.12
Cut-out, thermal	1.2.11.3
Cut-out, thermal, automatic reset	1.2.11.4
Cut-out, thermal, manual reset	1.2.11.5
Earthing, functional	1.2.13.9
Enclosure	1.2.6.1
Enclosure, electrical	1.2.6.4
Enclosure, fire	1.2.6.2
Enclosure, mechanical	1.2.6.3
Energy level, hazardous	1.2.8.9
Equipment, Class I	1.2.4.1
Equipment, Class II	1.2.4.2
Equipment, Class III	1.2.4.3
Equipment, direct plug-in	1.2.3.6
Equipment, for building-in	1.2.3.5
Equipment, hand-held	1.2.3.2
Equipment, movable	1.2.3.1

Equipment, permanently connected	1.2.5.3
Equipment, pluggable, type A	1.2.5.1
Equipment, pluggable, type B	1.2.5.2
Equipment, stationary	1.2.3.4
Equipment, transportable	1.2.3.3
Frequency, rated	1.2.1.4
Insulation, basic	1.2.9.2
Insulation, double	1.2.9.4
Insulation, functional	1.2.9.1
Insulation, reinforced	1.2.9.5
Insulation, supplementary	1.2.9.3
Interlock, safety	1.2.7.6
Limit, explosion	1.2.12.15
Limiter, temperature	1.2.11.2
Load, normal	1.2.2.1
Location, restricted access	1.2.7.3
Materials, flammability classification	1.2.12.1
Material, 5VA class	1.2.12.5
Material, 5VB class	1.2.12.6
Material, HF-1 class foamed	1.2.12.7
Material, HF-2 class foamed	1.2.12.8
Material, HBF class foamed	1.2.12.9
Material, HB40 class	1.2.12.10
Material, HB75 class	1.2.12.11
Material, V-0 class	1.2.12.2
Material, V-1 class	1.2.12.3
Material, V-2 class	1.2.12.4
Material, VTM-0 class	1.2.12.12
Material, VTM-1 class	1.2.12.13
Material, VTM-2 class	1.2.12.14
Network, telecommunication	1.2.13.8
Operation, continuous	1.2.2.3
Operation, intermittent	1.2.2.5
Operation, short-time	1.2.2.4
Operator	1.2.13.7
Part, decorative	1.2.6.5
Person, service	1.2.13.5
Range, rated frequency	1.2.1.5
Range, rated voltage	1.2.1.2
Supply, a.c. mains	1.2.8.1
Supply, d.c. mains	1.2.8.2
Surface, bounding	1.2.10.3
Test, routine	1.2.13.3
Test, sampling	1.2.13.2
Test, type	1.2.13.1
Thermostat	1.2.11.1
Time, rated operating	1.2.2.2
Tool	1.2.7.4
User	1.2.13.6
Voltage, d.c.	1.2.13.4
Voltage, hazardous	1.2.8.5
Voltage, mains transient	1.2.9.9
Voltage, peak working	1.2.9.7
Voltage, rated	1.2.1.1
Voltage, required withstand	1.2.9.8
Voltage, telecommunication network transient	1.2.9.10
Voltage, working	1.2.9.6

1.2.1 Equipment electrical ratings

1.2.1.1 RATED VOLTAGE: The supply voltage (for a three-phase AC MAINS SUPPLY, the line-to-line voltage) as declared by the manufacturer.

1.2.1.2 RATED VOLTAGE RANGE: The supply voltage range as declared by the manufacturer, expressed by its lower and upper RATED VOLTAGES.

1.2.1.3 RATED CURRENT: The input current of the equipment as declared by the manufacturer.

1.2.1.4 RATED FREQUENCY: The supply frequency as declared by the manufacturer.

1.2.1.5 RATED FREQUENCY RANGE: The supply frequency range as declared by the manufacturer, expressed by its lower and upper RATED FREQUENCIES.

1.2.2 Operating conditions

1.2.2.1 NORMAL LOAD: The mode of operation which approximates as closely as possible the most severe conditions of normal use in accordance with the operating instructions. However, when the conditions of actual use can obviously be more severe than the maximum recommended load conditions, a load is used that is representative of the maximum that can be applied.

NOTE NORMAL LOAD conditions for some types of equipment are given in annex L.

1.2.2.2 RATED OPERATING TIME: The operating time assigned to the equipment by the manufacturer.

1.2.2.3 CONTINUOUS OPERATION: Operation under NORMAL LOAD for an unlimited period.

1.2.2.4 SHORT-TIME OPERATION: Operation under NORMAL LOAD for a specified period, starting from cold, the intervals after each period of operation being sufficient to allow the equipment to cool down to room temperature.

1.2.2.5 INTERMITTENT OPERATION: Operation in a series of specified identical cycles, each composed of a period of operation under NORMAL LOAD followed by a rest period with the equipment switched off or running idle.

1.2.3 Equipment mobility

1.2.3.1 MOVABLE EQUIPMENT: Equipment which is either:

- 18 kg or less in mass and not fixed, or
- equipment with wheels, castors or other means to facilitate movement by the OPERATOR as required to perform its intended use.

1.2.3.2 HAND-HELD EQUIPMENT: MOVABLE EQUIPMENT, or a part of any kind of equipment, that is intended to be held in the hand during normal use.

1.2.3.3 TRANSPORTABLE EQUIPMENT: MOVABLE EQUIPMENT that is intended to be routinely carried by a USER.

NOTE Examples include laptop personal computers, pen-based tablet computers, and their portable accessories such as printers and CD-ROM drives.

1.2.3.4 STATIONARY EQUIPMENT: Equipment that is not MOVABLE EQUIPMENT.

1.2.3.5 EQUIPMENT FOR BUILDING-IN: Equipment intended to be installed in a prepared recess, such as in a wall, or similar situation.

NOTE In general, EQUIPMENT FOR BUILDING-IN does not have an ENCLOSURE on all sides, as some of the sides will be protected after installation.

1.2.3.6 DIRECT PLUG-IN EQUIPMENT: Equipment that is intended to be used without a power supply cord; the mains plug forms an integral part of the equipment ENCLOSURE so that the weight of the equipment is taken by the socket-outlet.

1.2.4 Classes of equipment – Protection against electric shock

NOTE Some information technology equipment cannot be identified as conforming to one of the following classes.

1.2.4.1 CLASS I EQUIPMENT: Equipment where protection against electric shock is achieved by:

- using BASIC INSULATION, and also
- providing a means of connection to the PROTECTIVE EARTHING CONDUCTOR in the building wiring those conductive parts that are otherwise capable of assuming HAZARDOUS VOLTAGES if the BASIC INSULATION fails.

NOTE CLASS I EQUIPMENT may have parts with DOUBLE INSULATION or REINFORCED INSULATION.

1.2.4.2 CLASS II EQUIPMENT: Equipment in which protection against electric shock does not rely on BASIC INSULATION only, but in which additional safety precautions, such as DOUBLE INSULATION or REINFORCED INSULATION are provided, there being no reliance on protective earthing.

1.2.4.3 CLASS III EQUIPMENT: Equipment in which protection against electric shock relies upon supply from SELV CIRCUITS and in which HAZARDOUS VOLTAGES are not generated.

NOTE For CLASS III EQUIPMENT, although there is no requirement for protection against electric shock, all other requirements of the standard apply.

1.2.5 Connection to the supply

1.2.5.1 PLUGGABLE EQUIPMENT TYPE A: Equipment which is intended for connection to the building installation wiring via a non-industrial plug and socket-outlet or a non-industrial appliance coupler, or both.

1.2.5.2 PLUGGABLE EQUIPMENT TYPE B: Equipment which is intended for connection to the building installation wiring via an industrial plug and socket-outlet or an appliance coupler, or both, complying with IEC 60309²⁾ or with a comparable national standard.

1.2.5.3 PERMANENTLY CONNECTED EQUIPMENT: Equipment which is intended for connection to the building installation wiring using screw terminals or other reliable means.

1.2.5.4 DETACHABLE POWER SUPPLY CORD: A flexible cord, for supply purposes, intended to be connected to the equipment by means of a suitable appliance coupler.

1.2.5.5 NON-DETACHABLE POWER SUPPLY CORD: A flexible cord, for supply purposes, fixed to or assembled with the equipment.

²⁾ A list of normative references is given in annex P.

Such a cord may be:

Ordinary: a flexible cord which can be easily replaced without special preparation of the cord or special TOOLS, or

Special: a flexible cord which is specially prepared, or requires the use of specially designed TOOLS for replacement, or is such that it cannot be replaced without damage to the equipment.

The term "specially prepared" includes provision of an integral cord guard, the use of cable lugs, formation of eyelets, etc., but not the re-shaping of the conductor before introduction into a terminal or the twisting of a stranded conductor to consolidate the end.

1.2.6 Enclosures

1.2.6.1 ENCLOSURE: A part of the equipment providing one or more of the functions described in 1.2.6.2, 1.2.6.3 or 1.2.6.4.

NOTE One type of ENCLOSURE can be inside another type (for example, an ELECTRICAL ENCLOSURE inside a FIRE ENCLOSURE or a FIRE ENCLOSURE inside an ELECTRICAL ENCLOSURE). Also, a single ENCLOSURE can provide the functions of more than one type (for example, the functions of both an ELECTRICAL ENCLOSURE and a FIRE ENCLOSURE).

1.2.6.2 FIRE ENCLOSURE: A part of the equipment intended to minimize the spread of fire or flames from within.

1.2.6.3 MECHANICAL ENCLOSURE: A part of the equipment intended to reduce the risk of injury due to mechanical and other physical hazards.

1.2.6.4 ELECTRICAL ENCLOSURE: A part of the equipment intended to limit access to parts that may be at HAZARDOUS VOLTAGES or HAZARDOUS ENERGY LEVELS or are in TNV CIRCUITS.

1.2.6.5 DECORATIVE PART: A part of the equipment, outside the ENCLOSURE, which has no safety function.

1.2.7 Accessibility

1.2.7.1 OPERATOR ACCESS AREA: An area to which, under normal operating conditions, one of the following applies:

- access can be gained without the use of a TOOL;
- the means of access is deliberately provided to the OPERATOR;
- the OPERATOR is instructed to enter regardless of whether or not a TOOL is needed to gain access.

The terms "access" and "accessible", unless qualified, relate to OPERATOR ACCESS AREA as defined above.

1.2.7.2 SERVICE ACCESS AREA: An area, other than an OPERATOR ACCESS AREA, where it is necessary for SERVICE PERSONS to have access even with the equipment switched on.

1.2.7.3 RESTRICTED ACCESS LOCATION: A location for equipment where both of the following paragraphs apply:

- access can only be gained by SERVICE PERSONS or by USERS who have been instructed about the reasons for the restrictions applied to the location and about any precautions that shall be taken; and
- access is through the use of a TOOL or lock and key, or other means of security, and is controlled by the authority responsible for the location.

NOTE The requirements for equipment intended for installation in RESTRICTED ACCESS LOCATIONS are the same as for OPERATOR ACCESS AREAS, except as given in 1.7.17, 2.1.3 and 4.5.1.

1.2.7.4 TOOL: A screwdriver or any other object which may be used to operate a screw, latch or similar fixing means.

1.2.7.5 BODY: All accessible conductive parts, shafts of handles, knobs, grips and the like, and metal foil in contact with all accessible surfaces of insulating material.

1.2.7.6 SAFETY INTERLOCK: A means either of preventing access to a hazardous area until the hazard is removed, or of automatically removing the hazardous condition when access is gained.

1.2.8 Circuits and circuit characteristics

1.2.8.1 AC MAINS SUPPLY: An a.c. power distribution system external to the equipment for supplying power to a.c. powered equipment. These power sources include public or private utilities and, unless otherwise specified in the standard (for example, 1.4.5), equivalent sources such as motor-driven generators and uninterruptible power supplies.

NOTE 1 See annex V for typical examples of a.c. power distribution systems.

NOTE 2 Where the term "mains" or "mains supply" is used, it refers to both an AC MAINS SUPPLY and a DC MAINS SUPPLY.

1.2.8.2 DC MAINS SUPPLY: A d.c. power distribution system, with or without batteries, external to the equipment, for supplying power to d.c. powered equipment, excluding:

- a d.c. supply providing power over TELECOMMUNICATION NETWORK wiring to remote equipment;
- a limited power source (see 2.5) whose open circuit voltage is less than or equal to 42,4 V d.c.;
- a d.c. supply whose open circuit voltage is greater than 42,4 V d.c. and less than or equal to 60 V d.c., and whose available power output is less than 240 VA.

Circuitry connected to a DC MAINS SUPPLY is considered to be a SECONDARY CIRCUIT in the meaning of this standard (see 2.10.3.3).

NOTE 1 See ITU-T Recommendation K.27 for bonding configurations and earthing inside a telecommunication building.

NOTE 2 Where the term "mains" or "mains supply" is used, it refers to both an AC MAINS SUPPLY and a DC MAINS SUPPLY.

1.2.8.3 PRIMARY CIRCUIT: A circuit which is directly connected to the AC MAINS SUPPLY. It includes, for example, the means for connection to the AC MAINS SUPPLY, the primary windings of transformers, motors and other loading devices.

NOTE Conductive parts of an INTERCONNECTING CABLE may be part of a PRIMARY CIRCUIT as stated in 1.2.11.6.

1.2.8.4 SECONDARY CIRCUIT: A circuit which has no direct connection to a PRIMARY CIRCUIT and derives its power from a transformer, converter or equivalent isolation device, or from a battery.

NOTE Conductive parts of an INTERCONNECTING CABLE may be part of a SECONDARY CIRCUIT as stated in 1.2.11.6.

1.2.8.5 HAZARDOUS VOLTAGE: A voltage exceeding 42,4 V peak, or 60 V d.c., existing in a circuit which does not meet the requirements for either a LIMITED CURRENT CIRCUIT or a TNV CIRCUIT.

1.2.8.6 ELV CIRCUIT: A SECONDARY CIRCUIT with voltages between any two conductors of the circuit, and between any one such conductor and earth (see 1.4.9), not exceeding 42,4 V peak, or 60 V d.c., under normal operating conditions, which is separated from HAZARDOUS VOLTAGE by BASIC INSULATION, and which neither meets all of the requirements for an SELV CIRCUIT nor meets all of the requirements for a LIMITED CURRENT CIRCUIT.

1.2.8.7 SELV CIRCUIT: A SECONDARY CIRCUIT which is so designed and protected that under normal operating conditions and single fault conditions, its voltages do not exceed a safe value.

NOTE 1 The limit values of voltages under normal operating conditions and single fault conditions (see 1.4.14) are specified in 2.2. See also table 1A.

NOTE 2 This definition of an SELV CIRCUIT differs from the term "SELV system" as used in IEC 61140.

1.2.8.8 LIMITED CURRENT CIRCUIT: A circuit which is so designed and protected that, under both normal operating conditions and single fault conditions, the current which can be drawn is not hazardous.

NOTE The limit values of currents under normal operating conditions and single fault conditions (see 1.4.14) are specified in 2.4.

1.2.8.9 HAZARDOUS ENERGY LEVEL: An available power level of 240 VA or more having a duration of 60 s or more, or a stored energy level of 20 J or more (for example, from one or more capacitors), at a potential of 2 V or more.

1.2.8.10 TNV CIRCUIT: A circuit which is in the equipment and to which the accessible area of contact is limited and that is so designed and protected that, under normal operating conditions and single fault conditions (see 1.4.14), the voltages do not exceed specified limit values.

A TNV CIRCUIT is considered to be a SECONDARY CIRCUIT in the meaning of this standard.

NOTE 1 The specified limit values of voltages under normal operating conditions and single fault conditions (see 1.4.14) are given in 2.3.1. Requirements regarding accessibility of TNV CIRCUITS are given in 2.1.1.1.

NOTE 2 Conductive parts of an INTERCONNECTING CABLE may be part of a TNV CIRCUIT as stated in 1.2.11.6.

TNV CIRCUITS are classified as TNV-1, TNV-2 and TNV-3 CIRCUITS as defined in 1.2.8.11, 1.2.8.12 and 1.2.8.13.

NOTE 3 The voltage relationships between SELV and TNV CIRCUITS are shown in table 1A.

Table 1A – Voltage ranges of SELV and TNV circuits

Overvoltages from TELECOMMUNICATION NETWORKS possible?	Overvoltages from CABLE DISTRIBUTION SYSTEMS possible ?	Normal operating voltages	
		Within SELV CIRCUIT limits	Exceeding SELV CIRCUIT limits but within TNV CIRCUIT limits
Yes	Yes	TNV-1 CIRCUIT	TNV-3 CIRCUIT
No	Not applicable	SELV CIRCUIT	TNV-2 CIRCUIT

1.2.8.11 TNV-1 CIRCUIT: A TNV CIRCUIT:

- whose normal operating voltages do not exceed the limits for an SELV CIRCUIT under normal operating conditions; and
- on which overvoltages from TELECOMMUNICATION NETWORKS and CABLE DISTRIBUTION SYSTEMS are possible.

1.2.8.12 TNV-2 CIRCUIT: A TNV CIRCUIT:

- whose normal operating voltages exceed the limits for an SELV CIRCUIT under normal operating conditions; and
- which is not subject to overvoltages from TELECOMMUNICATION NETWORKS.

1.2.8.13 TNV-3 CIRCUIT: A TNV CIRCUIT:

- whose normal operating voltages exceed the limits for an SELV CIRCUIT under normal operating conditions; and
- on which overvoltages from TELECOMMUNICATION NETWORKS and CABLE DISTRIBUTION SYSTEMS are possible.

1.2.9 Insulation

1.2.9.1 FUNCTIONAL INSULATION: Insulation that is necessary only for the correct functioning of the equipment.

NOTE FUNCTIONAL INSULATION by definition does not protect against electric shock. It may, however, reduce the likelihood of ignition and fire.

1.2.9.2 BASIC INSULATION: Insulation to provide basic protection against electric shock.

1.2.9.3 SUPPLEMENTARY INSULATION: Independent insulation applied in addition to BASIC INSULATION in order to reduce the risk of electric shock in the event of a failure of the BASIC INSULATION.

1.2.9.4 DOUBLE INSULATION: Insulation comprising both BASIC INSULATION and SUPPLEMENTARY INSULATION.

1.2.9.5 REINFORCED INSULATION: A single insulation system which provides a degree of protection against electric shock equivalent to DOUBLE INSULATION under the conditions specified in this standard.

NOTE The term "insulation system" does not imply that the insulation has to be in one homogeneous piece. It may comprise several layers which cannot be tested as SUPPLEMENTARY INSULATION or BASIC INSULATION.

1.2.9.6 WORKING VOLTAGE: The highest voltage to which the insulation or the component under consideration is, or can be, subjected when the equipment is operating under conditions of normal use.

1.2.9.7 PEAK WORKING VOLTAGE: The highest peak or d.c. value of a WORKING VOLTAGE, including repetitive peak impulses generated in the equipment, but not including external transients.

1.2.9.8 REQUIRED WITHSTAND VOLTAGE: The peak voltage that the insulation under consideration is required to withstand.

1.2.9.9 MAINS TRANSIENT VOLTAGE: The highest peak voltage expected at the power input to the equipment, arising from external transients on the AC MAINS SUPPLY or DC MAINS SUPPLY.

1.2.9.10 TELECOMMUNICATION NETWORK TRANSIENT VOLTAGE: The highest peak voltage expected at the TELECOMMUNICATION NETWORK connection point of the equipment, arising from external transients on the network.

NOTE The effect of transients from CABLE DISTRIBUTION SYSTEMS is not taken into account.

1.2.10 Clearances and creepage distances

1.2.10.1 CLEARANCE: The shortest distance between two conductive parts, or between a conductive part and the BOUNDING SURFACE of the equipment, measured through air.

1.2.10.2 CREEPAGE DISTANCE: The shortest path between two conductive parts, or between a conductive part and the BOUNDING SURFACE of the equipment, measured along the surface of the insulation.

1.2.10.3 BOUNDING SURFACE: The outer surface of the ELECTRICAL ENCLOSURE, considered as though metal foil were pressed into contact with accessible surfaces of insulating material.

1.2.11 Components

1.2.11.1 THERMOSTAT: A cycling temperature-sensing control, which is intended to keep a temperature between two particular values under normal operating conditions and which may have provision for setting by the OPERATOR.

1.2.11.2 TEMPERATURE LIMITER: A temperature-sensing control which is intended to keep a temperature below or above one particular value during normal operating conditions and which may have provision for setting by the OPERATOR.

NOTE A TEMPERATURE LIMITER may be of the automatic reset or of the manual reset type.

1.2.11.3 THERMAL CUT-OUT: A temperature-sensing control intended to operate under abnormal operating conditions and which has no provision for the OPERATOR to change the temperature setting.

NOTE A THERMAL CUT-OUT may be of the automatic reset or of the manual reset type.

1.2.11.4 THERMAL CUT-OUT, AUTOMATIC RESET: A THERMAL CUT-OUT which automatically restores the current after the relevant part of the equipment has cooled down sufficiently.

1.2.11.5 THERMAL CUT-OUT, MANUAL RESET: A THERMAL CUT-OUT which requires resetting by hand, or replacement of a part, in order to restore the current.

1.2.11.6 INTERCONNECTING CABLE: A cable used to electrically connect an accessory to a unit of information technology equipment, to interconnect units in a system or to connect a unit to a TELECOMMUNICATION NETWORK or to a CABLE DISTRIBUTION SYSTEM. Such a cable may carry any type of circuit from one unit to another.

NOTE A power supply cord for connection to the mains supply is not an INTERCONNECTING CABLE.

1.2.12 Flammability

1.2.12.1 FLAMMABILITY CLASSIFICATION OF MATERIALS: The recognition of the burning behaviour of materials and their ability to extinguish if ignited. Materials are classified as in 1.2.12.2 to 1.2.12.14 when tested in accordance with IEC 60695-11-10, IEC 60695-11-20, ISO 9772 or ISO 9773.

NOTE 1 When applying the requirements in this standard, HF-1 CLASS FOAMED MATERIALS are regarded as better than those of CLASS HF-2, and HF-2 better than HBF.

NOTE 2 Similarly, other MATERIALS, including rigid (engineering structural) foam of CLASS 5VA are regarded as better than those of CLASS 5VB, 5VB better than V-0, V-0 better than V-1, V-1 better than V-2, V-2 better than HB40 and HB40 better than HB75.

NOTE 3 Similarly, other MATERIALS of CLASS VTM-0 are regarded as better than those of CLASS VTM-1 and VTM-1 better than VTM-2.

NOTE 4 Materials of FLAMMABILITY CLASSES VTM-0, VTM-1 and VTM-2 are considered to be equivalent to materials of FLAMMABILITY CLASSES V-0, V-1 and V-2, respectively, but only for their flammability properties. Their electrical and mechanical properties are not necessarily equivalent.

NOTE 5 Certain flammability classes are replacing the classes used in earlier editions of this standard. The equivalence of the old and the new classes is shown below.

Old class	New class	Equivalence
–	5VA (1.2.12.5)	5VA is not required in this standard.
5V	5VB (1.2.12.6)	Materials that pass the tests for class 5V in clause A.9 of earlier editions of this standard are equivalent to 5VB or better.
HB	HB40 (1.2.12.10)	Samples of materials in a thickness of 3 mm that pass the tests of clause A.8 in earlier editions of this standard (maximum burning rate 40 mm/min during test) are equivalent to HB40.
	HB75 (1.2.12.11)	Samples of materials in a thickness of less than 3 mm that pass the tests of clause A.8 in earlier editions of this standard (maximum burning rate 75 mm/min during test) are equivalent to HB75.

1.2.12.2 V-0 CLASS MATERIAL: A material tested in the thinnest significant thickness used and classified V-0 according to IEC 60695-11-10.

1.2.12.3 V-1 CLASS MATERIAL: A material tested in the thinnest significant thickness used and classified V-1 according to IEC 60695-11-10.

1.2.12.4 V-2 CLASS MATERIAL: A material tested in the thinnest significant thickness used and classified V-2 according to IEC 60695-11-10.

1.2.12.5 5VA CLASS MATERIAL: A material tested in the thinnest significant thickness used and classified 5VA according to IEC 60695-11-20.

1.2.12.6 5VB CLASS MATERIAL: A material tested in the thinnest significant thickness used and classified 5VB according to IEC 60695-11-20.

1.2.12.7 HF-1 CLASS FOAMED MATERIAL: A foamed material tested in the thinnest significant thickness used and classified HF-1 according to ISO 9772.

1.2.12.8 HF-2 CLASS FOAMED MATERIAL: A foamed material tested in the thinnest significant thickness used and classified HF-2 according to ISO 9772.

1.2.12.9 HBF CLASS FOAMED MATERIAL: A foamed material tested in the thinnest significant thickness used and classified HBF according to ISO 9772.

1.2.12.10 HB40 CLASS MATERIAL: A material tested in the thinnest significant thickness used and classified HB40 according to IEC 60695-11-10.

1.2.12.11 HB75 CLASS MATERIAL: A material tested in the thinnest significant thickness used and classified HB75 according to IEC 60695-11-10.

1.2.12.12 VTM-0 CLASS MATERIAL: A material tested in the thinnest significant thickness used and classified VTM-0 according to ISO 9773.

1.2.12.13 VTM-1 CLASS MATERIAL: A material tested in the thinnest significant thickness used and classified VTM-1 according to ISO 9773.

1.2.12.14 VTM-2 CLASS MATERIAL: A material tested in the thinnest significant thickness used and classified VTM-2 according to ISO 9773.

1.2.12.15 EXPLOSION LIMIT: The lowest concentration of a combustible material in a mixture containing any of the following: gases, vapours, mists or dusts, in which a flame is able to propagate after removal of the ignition source.

1.2.13 Miscellaneous

1.2.13.1 TYPE TEST: A test on a representative sample of the equipment with the objective of determining if the equipment, as designed and manufactured, can meet the requirements of this standard.

1.2.13.2 SAMPLING TEST: A test on a number of samples taken at random from a batch. [IEV 151-04-17, modified]

1.2.13.3 ROUTINE TEST: A test to which each individual sample is subjected during or after manufacture to check if the sample complies with certain criteria. [IEV 151-04-16, modified]

1.2.13.4 DC VOLTAGE: The average value of a voltage (as measured by a moving coil meter) having a peak-to-peak ripple not exceeding 10 % of the average value.

NOTE Where peak-to-peak ripple exceeds 10 % of the average value, the requirements related to peak voltage are applicable.

1.2.13.5 SERVICE PERSON: A person having appropriate technical training and experience necessary to be aware of hazards to which that person may be exposed in performing a task and of measures to minimize the risks to that person or other persons.

1.2.13.6 USER: Any person, other than a SERVICE PERSON. The term USER in this standard is the same as the term OPERATOR and the two terms can be interchanged.

1.2.13.7 OPERATOR: See USER (1.2.13.6).

1.2.13.8 TELECOMMUNICATION NETWORK: A metallicly terminated transmission medium intended for communication between equipment that may be located in separate buildings, excluding:

- the mains system for supply, transmission and distribution of electrical power, if used as a telecommunication transmission medium;
- CABLE DISTRIBUTION SYSTEMS;
- SELV CIRCUITS connecting units of information technology equipment.

NOTE 1 The term TELECOMMUNICATION NETWORK is defined in terms of its functionality, not its electrical characteristics. A TELECOMMUNICATION NETWORK is not itself defined as being either an SELV CIRCUIT or a TNV CIRCUIT. Only the circuits in the equipment are so classified.

NOTE 2 A TELECOMMUNICATION NETWORK may be:

- publicly or privately owned;
- subject to transient overvoltages due to atmospheric discharges and faults in power distribution systems;
- subject to longitudinal (common mode) voltages induced from nearby power lines or electric traction lines.

NOTE 3 Examples of TELECOMMUNICATION NETWORKS are:

- a public switched telephone network;
- a public data network;
- an Integrated Services Digital Network (ISDN);
- a private network with electrical interface characteristics similar to the above.

1.2.13.9 FUNCTIONAL EARTHING: The earthing of a point in equipment or in a system, which is necessary for a purpose other than safety. [IEV 195-01-13, modified]

1.2.13.10 PROTECTIVE EARTHING CONDUCTOR: A conductor in the building installation wiring, or in the power supply cord, connecting a main protective earthing terminal in the equipment to an earth point in the building installation.

NOTE In some countries, the term "grounding conductor" is used instead of "PROTECTIVE EARTHING CONDUCTOR".

1.2.13.11 PROTECTIVE BONDING CONDUCTOR: A conductor in the equipment, or a combination of conductive parts in the equipment, connecting a main protective earthing terminal to a part of the equipment that is required to be earthed for safety purposes.

1.2.13.12 TOUCH CURRENT: Electric current through a human body when it touches one or more accessible parts. [IEV 195-05-21, modified]

NOTE TOUCH CURRENT was previously included in the term "leakage current".

1.2.13.13 PROTECTIVE CONDUCTOR CURRENT: Current flowing through the PROTECTIVE EARTHING CONDUCTOR under normal operating conditions.

NOTE PROTECTIVE CONDUCTOR CURRENT was previously included in the term "leakage current".

1.2.13.14 CABLE DISTRIBUTION SYSTEM: A metallicly terminated transmission medium mainly intended for transmission of video and/or audio signals between separate buildings or between outdoor antennas and buildings, excluding:

- the mains system for supply, transmission and distribution of electric power, if used as a communication transmission medium;
- TELECOMMUNICATION NETWORKS;
- SELV CIRCUITS connecting units of information technology equipment.

NOTE 1 Examples of CABLE DISTRIBUTION SYSTEMS are:

- local area cable networks, community antenna television systems and master antenna television systems providing video and audio signal distribution;
- outdoor antennas including satellite dishes, receiving antennas, and other similar devices.

NOTE 2 CABLE DISTRIBUTION SYSTEMS may be subjected to greater transients than TELECOMMUNICATION NETWORKS (see 7.3.1).

1.3 General requirements

1.3.1 Application of requirements

The requirements detailed in this standard shall be applied only if safety is involved.

In order to establish whether or not safety is involved, the circuits and construction shall be carefully investigated to take into account the consequences of possible failures.

1.3.2 Equipment design and construction

Equipment shall be so designed and constructed that, under all conditions of normal use and under likely abnormal use or single fault conditions (see 1.4.14), protection is provided to reduce the risk of personal injury from electric shock and other hazards, and against spread of fire originating in the equipment.

Compliance is checked by inspection and by the relevant tests.

1.3.3 Supply voltage

Equipment shall be designed to be safe at any supply voltage to which it is intended to be connected.

Compliance is checked by inspection and by carrying out the relevant tests of this standard under the conditions specified in 1.4.5.

1.3.4 Constructions not specifically covered

Where the equipment involves technologies and materials or methods of construction not specifically covered in this standard, the equipment shall provide a level of safety not less than that generally afforded by this standard and the principles of safety contained herein.

NOTE The need for additional detailed requirements to cope with a new situation should be brought promptly to the attention of the appropriate committee.

1.3.5 Equivalent materials

Where the standard specifies a particular grade of insulation, the use of a better grade of insulation is permitted. Similarly, where the standard requires material of a particular FLAMMABILITY CLASS, the use of a better class is permitted.

1.3.6 Orientation during transport and use

Where it is clear that the orientation of use of equipment is likely to have a significant effect on the application of the requirements or the results of tests, all orientations of use permitted in the installation or USER instructions shall be taken into account. For TRANSPORTABLE EQUIPMENT, all orientations of transport and use shall be taken into account.

NOTE The above may apply to 4.1, 4.5, 4.6 and 5.3.

1.3.7 Choice of criteria

Where the standard permits a choice between different criteria for compliance, or between different methods or conditions of test, the choice is specified by the manufacturer.

1.3.8 Examples mentioned in the standard

Where examples of equipment, parts, methods of construction, design techniques and faults are given in the standard, prefaced by "for example" or "such as", other examples, situations and solutions are not excluded.

1.3.9 Conductive liquids

For the electrical requirements of this standard, conductive liquids shall be treated as conductive parts.

1.4 General conditions for tests

1.4.1 Application of tests

The tests detailed in this standard shall be carried out only if safety is involved.

If it is evident from the design and construction of the equipment that a particular test is not applicable, the test is not made.

Unless otherwise stated, upon conclusion of the tests, the equipment need not be operational.

1.4.2 Type tests

Except where otherwise stated, the tests specified in this standard are TYPE TESTS.

1.4.3 Test samples

Unless otherwise specified, the sample or samples under test shall be representative of the equipment the USER would receive, or shall be the actual equipment ready for shipment to the USER.

As an alternative to carrying out tests on the complete equipment, tests may be carried out separately on circuits, components or subassemblies outside the equipment, provided that inspection of the equipment and circuit arrangements indicates that the results of such testing will be representative of the results of testing the assembled equipment. If any such test indicates a likelihood of non-conformance in the complete equipment, the test shall be repeated in the equipment.

If a test specified in this standard could be destructive, it is permitted to use a model to represent the condition to be evaluated.

NOTE 1 The tests should be carried out in the following order:

- component or material pre-selection;
- component or subassembly bench tests;
- tests where the equipment is not energized;
- live tests:
 - under normal operating conditions;
 - under abnormal operating conditions;
 - involving likely destruction.

NOTE 2 In view of the resources involved in testing and in order to minimize waste, it is recommended that all parties concerned jointly consider the test programme, the test samples and the test sequence.

1.4.4 Operating parameters for tests

Except where specific test conditions are stated elsewhere in the standard and where it is clear that there is a significant impact on the results of the test, the tests shall be carried out under the most unfavourable combination within the manufacturer's operating specifications of the following parameters:

- supply voltage (see 1.4.5);
- supply frequency (see 1.4.6);
- operating temperature (see 1.4.12);
- physical location of equipment and position of movable parts;
- operating mode;
- adjustment of THERMOSTATS, regulating devices or similar controls in OPERATOR ACCESS AREAS, which are:
 - adjustable without the use of a TOOL; or
 - adjustable using a means, such as a key or a TOOL, deliberately provided for the OPERATOR.

1.4.5 Supply voltage for tests

In determining the most unfavourable voltage for the power to energize the equipment under test (EUT), the following variables shall be taken into account:

- multiple RATED VOLTAGES;
- tolerances on RATED VOLTAGE as specified below;
- extremes of RATED VOLTAGE RANGES.

If the equipment is intended for direct connection to an AC MAINS SUPPLY, the tolerances on RATED VOLTAGE shall be taken as +6 % and –10 %, unless:

- the RATED VOLTAGE is 230 V single-phase or 400 V three-phase, in which case the tolerance shall be taken as +10 % and –10 %; or
- a wider tolerance is declared by the manufacturer, in which case the tolerance shall be taken as this wider value.

If the equipment is intended only for connection to an a.c. mains equivalent source, such as a motor-driven generator or an uninterruptible power supply (see 1.2.8.1), or a source other than an AC MAINS SUPPLY or a DC MAINS SUPPLY, the tolerances on RATED VOLTAGE shall be declared by the manufacturer.

If equipment is intended for connection to a DC MAINS SUPPLY, the tolerance shall be taken as +20 % and –15 %, unless declared otherwise by the manufacturer.

When testing equipment designed for d.c. only, the possible influence of polarity shall be taken into account.

1.4.6 Supply frequency for tests

In determining the most unfavourable frequency for the power to energize the EUT, different RATED FREQUENCIES within the RATED FREQUENCY RANGE shall be taken into account (for example, 50 Hz and 60 Hz) but consideration of the tolerance on a RATED FREQUENCY (for example, 50 Hz \pm 0,5 Hz) is not normally necessary.

1.4.7 Electrical measuring instruments

Electrical measuring instruments shall have adequate bandwidth to provide accurate readings, taking into account all components (d.c., AC MAINS SUPPLY frequency, high frequency and harmonic content) of the parameter being measured. If the r.m.s. value is measured, care shall be taken that measuring instruments give true r.m.s. readings of non-sinusoidal waveforms as well as sinusoidal waveforms.

1.4.8 Normal operating voltages

For the purposes of:

- determining WORKING VOLTAGES (see 1.2.9.6); and
- classifying circuits in the equipment as ELV CIRCUITS, SELV CIRCUITS, TNV-1 CIRCUITS, TNV-2 CIRCUITS, TNV-3 CIRCUITS, or HAZARDOUS VOLTAGE circuits;

the following voltages shall be considered:

- normal operating voltages generated in the equipment, including repetitive peak voltages such as those associated with switch mode power supplies;
- normal operating voltages generated outside the equipment, including ringing signals received from TELECOMMUNICATION NETWORKS.

For these purposes, unwanted, externally generated, non-repetitive transient voltages (for example, MAINS TRANSIENT VOLTAGES and TELECOMMUNICATION NETWORK TRANSIENT VOLTAGES) induced by power distribution system switching and lightning surges, shall not be considered:

- when determining WORKING VOLTAGES, because such transients have been taken into account in the procedures for determining minimum CLEARANCES, see 2.10.3 and annex G;
- when classifying circuits in the equipment, except when distinguishing between SELV CIRCUITS and TNV-1 CIRCUITS and between TNV-2 CIRCUITS and TNV-3 CIRCUITS, see 1.2.8.10, table 1A.

NOTE The effects of unwanted steady-state voltages generated outside the equipment (for example, earth potential differences and voltages induced on TELECOMMUNICATION NETWORKS by electric train systems) are controlled by installation practices or by appropriate isolation in the equipment. Such measures are application dependent and are not dealt with by this standard.

1.4.9 Measurement of voltage to earth

Where the standard specifies a voltage between a conductive part and earth, all of the following earthed parts are considered:

- the protective earthing terminal (if any); and
- any other conductive part required to be connected to protective earth (for example see 2.6.1); and
- any conductive part that is earthed within the equipment for functional reasons.

Parts that will be earthed in the application by connection to other equipment, but are unearthed in the equipment as tested, shall be connected to earth at the point by which the highest voltage is obtained. When measuring a voltage between earth and a conductor in a circuit that will not be earthed in the intended application of the equipment, a non-inductive resistor of $5\,000\ \Omega \pm 10\%$ shall be connected across the voltage measuring instrument.

Voltage drop in the PROTECTIVE EARTHING CONDUCTOR of the power supply cord, or in an earthed conductor in other external wiring, is not included in the measurements.

1.4.10 Loading configuration of the EUT

In determining the input current, and where other test results could be affected, the following variables shall be considered and adjusted to give the most unfavourable results:

- loads due to optional features, offered or provided by the manufacturer for inclusion in or with the EUT;
- loads due to other units of equipment intended by the manufacturer to draw power from the EUT;
- loads which could be connected to any standard supply outlets in OPERATOR ACCESS AREAS on the equipment, up to the value indicated in the marking required by 1.7.5.

It is permitted to use artificial loads to simulate such loads during testing.

1.4.11 Power from a telecommunication network

For the purpose of this standard, the power available from a TELECOMMUNICATION NETWORK is considered to be limited to 15 VA.

1.4.12 Temperature measurement conditions

1.4.12.1 General

Temperatures measured on the EUT shall conform to 1.4.12.2 or 1.4.12.3, as applicable, all temperatures being in degrees Celsius ($^{\circ}\text{C}$); where

T is the temperature of the given part measured under the prescribed test conditions;

T_{max} is the maximum temperature specified for compliance with the test;

T_{amb} is the ambient temperature during test;

T_{ma} is the maximum ambient temperature permitted by the manufacturer's specification, or 25°C , whichever is greater.

1.4.12.2 Temperature dependent equipment

For equipment where the amount of heating or cooling is designed to be dependent on temperature (for example, the equipment contains a fan that has a higher speed at a higher temperature), the temperature measurement is made at the least favourable ambient temperature within the manufacturer's specified operating range. In this case:

T shall not exceed T_{max} .

NOTE 1 In order to find the highest value of T for each component, it may be necessary to conduct several tests at different values of T_{amb} .

NOTE 2 The least favourable value of T_{amb} may be different for different components.

1.4.12.3 Non-temperature dependent equipment

For equipment where the amount of heating or cooling is not designed to be dependent on ambient temperature, it is permitted to use the method in 1.4.12.2. Alternatively, the test is performed at any value of T_{amb} within the manufacturer's specified operating range. In this case:

T shall not exceed $(T_{\text{max}} + T_{\text{amb}} - T_{\text{ma}})$.

During the test, T_{amb} should not exceed T_{ma} unless agreed by all parties involved.

1.4.13 Temperature measurement methods

Unless a particular method is specified, the temperatures of windings shall be determined either by the thermocouple method or by the resistance method (see annex E). The temperatures of parts other than windings shall be determined by the thermocouple method. Any other suitable method of temperature measurement, which does not noticeably influence the thermal balance and which achieves an accuracy sufficient to show compliance, is also permitted. The choice of and position of temperature sensors shall be made so that they have minimum effect on the temperature of the part under test.

1.4.14 Simulated faults and abnormal conditions

Where it is required to apply simulated faults or abnormal operating conditions, these shall be applied in turn and one at a time. Faults which are the direct consequence of a simulated fault or abnormal operating condition are considered to be part of that simulated fault or abnormal operating condition.

When applying simulated faults or abnormal operating conditions, parts, supplies, consumable materials, media and recording materials shall be in place if they are likely to have an effect on the outcome of the test.

Where there is a specific reference to a single fault, the single fault consists of a single failure of any insulation (excluding DOUBLE INSULATION or REINFORCED INSULATION) or a single failure of any component (excluding components with DOUBLE INSULATION or REINFORCED INSULATION).

The equipment, circuit diagrams and component specifications are examined to determine those fault conditions that might reasonably be expected to occur. Examples include:

- short circuits and open circuits of semiconductor devices and capacitors;
- faults causing continuous dissipation in resistors designed for intermittent dissipation;
- internal faults in integrated circuits causing excessive dissipation;
- failure of BASIC INSULATION between current-carrying parts of the PRIMARY CIRCUIT and
 - accessible conductive parts;
 - earthed conductive screens (see clause C.2);
 - parts of SELV CIRCUITS;
 - parts of LIMITED CURRENT CIRCUITS.

1.4.15 Compliance by inspection of relevant data

Where in this standard compliance of materials, components or subassemblies is checked by inspection or by testing of properties, it is permitted to confirm compliance by reviewing any relevant data or previous test results that are available instead of carrying out the specified TYPE TESTS.

1.5 Components

1.5.1 General

Where safety is involved, components shall comply either with the requirements of this standard or with the safety aspects of the relevant IEC component standards.

NOTE 1 An IEC component standard is considered relevant only if the component in question clearly falls within its scope.

NOTE 2 In Sweden, switches containing mercury are not allowed.

A component which is to be connected to an SELV CIRCUIT and also to an ELV CIRCUIT or to a part at HAZARDOUS VOLTAGE shall comply with the requirements of 2.2.

NOTE 3 An example of such a component is a relay with different supplies connected to different elements (coils and contacts).

1.5.2 Evaluation and testing of components

Evaluation and testing of components shall be carried out as follows:

- *a component that has been demonstrated to comply with a standard harmonized with the relevant IEC component standard shall be checked for correct application and use in accordance with its rating. It shall be subjected to the applicable tests of this standard as part of the equipment with the exception of those tests which are part of the relevant IEC component standard;*
- *a component that has not been demonstrated to comply with a relevant standard as above shall be checked for correct application and use in accordance with its specified rating. It shall be subjected to the applicable tests of this standard, as part of the equipment, and to the applicable tests of the component standard, under the conditions occurring in the equipment;*

NOTE The applicable test for compliance with a component standard is, in general, carried out separately.

- *where no relevant IEC component standard exists, or where components are used in circuits not in accordance with their specified ratings, the components shall be tested under the conditions occurring in the equipment. The number of samples required for test is, in general, the same as required by an equivalent standard.*

1.5.3 Thermal controls

Thermal controls shall be tested in accordance with annex K.

1.5.4 Transformers

Transformers shall comply with the relevant requirements of this standard, including those of annex C.

1.5.5 Interconnecting cables

INTERCONNECTING CABLES provided as part of the equipment shall comply with the relevant requirements of this standard and shall not present a hazard in the meaning of this standard whether they are detachable or non-detachable.

For INTERCONNECTING CABLES supplied alone (for example, printer cables), it is permitted to apply the requirements of this subclause at the option of the manufacturer.

It is permitted to treat cables, or those parts of cables, that are within an equipment ENCLOSURE either as INTERCONNECTING CABLES or as internal wiring.

1.5.6 Capacitors in primary circuits

A capacitor connected between two line conductors of the PRIMARY CIRCUIT, or between one line conductor and the neutral conductor, shall comply with IEC 60384-14:1993, subclass X1 or X2. The duration of the damp heat, steady state test as specified in 4.12 of IEC 60384-14:1993 shall be 21 days.

A capacitor connected between the PRIMARY CIRCUIT and protective earth shall comply with IEC 60384-14:1993, subclass Y1, Y2 or Y4, as applicable.

NOTE The above requirement does not apply to a capacitor connected from a HAZARDOUS VOLTAGE SECONDARY CIRCUIT to earth. For such a capacitor, the electric strength test of 5.2.2 is considered sufficient.

Compliance is checked by inspection.

1.5.7 Double insulation or reinforced insulation bridged by components

1.5.7.1 General

Compliance with 1.5.7.2 to 1.5.7.4 is checked by inspection and relevant tests.

1.5.7.2 Bridging capacitors

It is permitted to bridge DOUBLE INSULATION or REINFORCED INSULATION by:

- a single capacitor complying with IEC 60384-14:1993, subclass Y1; or
- a single capacitor complying with IEC 60384-14:1993, subclass Y2, where the equipment RATED VOLTAGE is less than 150 V with respect to neutral or earth; or
- two capacitors in series, each complying with IEC 60384-14:1993, subclass Y2 or Y4.

A Y1 capacitor, or a Y2 capacitor used in accordance with the above second dash, is considered to have REINFORCED INSULATION.

Where two capacitors are used in series, they shall each be rated for the total WORKING VOLTAGE across the pair and shall have the same nominal capacitance value.

1.5.7.3 Bridging resistors

It is permitted to bridge DOUBLE INSULATION or REINFORCED INSULATION by two resistors in series. The resistors shall each comply with the requirements of 2.10.3 and 2.10.4 for BASIC INSULATION or SUPPLEMENTARY INSULATION, as applicable, between their terminations for the total WORKING VOLTAGE across the pair and shall have the same nominal resistance value.

1.5.7.4 Accessible parts

Where accessible conductive parts or circuits are separated from other parts by DOUBLE INSULATION or REINFORCED INSULATION that is bridged by components in accordance with 1.5.7.2 or 1.5.7.3, the accessible parts or circuits shall comply with the requirements for LIMITED CURRENT CIRCUITS in 2.4. These requirements shall apply after electric strength testing of the insulation has been carried out.

1.5.8 Components in equipment for IT power distribution systems

For equipment to be connected to IT power distribution systems, components connected between line and earth shall be capable of withstanding the stress due to the line-to-line voltage. However, capacitors rated for the applicable line-to-neutral voltage are permitted in such applications if they comply with IEC 60384-14:1993, subclass Y1, Y2 or Y4.

NOTE 1 The above capacitors are endurance tested at 1,7 times the voltage rating of the capacitor.

NOTE 2 In Norway, due to the IT power distribution system used (see annex V, figure V.7), capacitors are required to be rated for the applicable line-to-line voltage (230 V).

Compliance is checked by inspection.

1.6 Power interface

1.6.1 AC power distribution systems

AC power distribution systems are classified as TN, TT or IT (see annex V).

NOTE In Australia, TN-S and other systems apply.

1.6.2 Input current

The steady state input current of the equipment shall not exceed the RATED CURRENT by more than 10 % under NORMAL LOAD.

NOTE See also 1.4.10.

Compliance is checked by measuring the input current of the equipment at NORMAL LOAD under the following conditions:

- *where an equipment has more than one RATED VOLTAGE, the input current is measured at each RATED VOLTAGE;*
- *where an equipment has one or more RATED VOLTAGE RANGES, the input current is measured at each end of each RATED VOLTAGE RANGE. Where a single value of RATED CURRENT is marked (see 1.7.1), it is compared with the higher value of input current measured in the associated voltage range. Where two values of RATED CURRENT are marked, separated by a hyphen, they are compared with the two values measured in the associated voltage range.*

In each case, the readings are taken when the input current has stabilized. If the current varies during the normal operating cycle, the steady-state current is taken as the mean indication of the value, measured on a recording r.m.s. ammeter, during a representative period.

1.6.3 Voltage limit of hand-held equipment

The RATED VOLTAGE of HAND-HELD EQUIPMENT shall not exceed 250 V.

Compliance is checked by inspection.

1.6.4 Neutral conductor

The neutral conductor, if any, shall be insulated from earth and from the BODY throughout the equipment as if it were a line conductor. Components connected between neutral and earth shall be rated for the line-to-neutral voltage.

Compliance is checked by inspection.

1.7 Markings and instructions

NOTE Additional requirements for markings and instructions are contained in the following subclauses:

2.1.1.2	USER access within battery compartments
2.3.2	Separation from other circuits and from accessible parts
2.6.1	Unearthed parts in SERVICE ACCESS AREAS
2.6.2	Functional earthing
2.7.1	Protection provided by the building installation
2.7.6	Neutral fusing
3.2.1.2	Connection of a DC MAINS SUPPLY
3.3.7	Grouping of wiring terminals
3.4.6	Provision of two-pole disconnect devices
3.4.7	Provision of four-pole disconnect devices
3.4.9	Plugs as disconnect devices
3.4.10	Interconnected equipment
3.4.11	Multiple power sources
4.1	Equipment stability
4.3.3	Adjustable controls
4.3.5	Connection of plugs and sockets
4.3.13.4	Human exposure to UV radiation
4.3.13.5	Classification of equipment containing a laser
4.4.2	Hazardous moving parts
4.5.1, table 4B	Marking of hot parts
4.6.2	Stationary equipment on non-combustible floors
4.6.3	Removable doors and covers
5.1.7	TOUCH CURRENT exceeding 3,5 mA
5.1.8.2	Summation of TOUCH CURRENTS
6.1.1	Protection from HAZARDOUS VOLTAGES in equipment connected to a TELECOMMUNICATION NETWORK
6.1.2.2	Earthing of equipment connected to a TELECOMMUNICATION NETWORK
7.1	Protection from HAZARDOUS VOLTAGES in equipment connected to a CABLE DISTRIBUTION SYSTEM
7.3.1	Earthing provisions for a CABLE DISTRIBUTION SYSTEM
G.2.1	Additional protection for equipment in Overvoltage Categories III and IV

Compliance with each subclause of 1.7 is checked by inspection unless otherwise specified (see 1.7.13).

1.7.1 Power rating

Equipment shall be provided with a power rating marking, the purpose of which is to specify a supply of correct voltage and frequency, and of adequate current-carrying capacity.

If a unit is not provided with a means for direct connection to an AC MAINS SUPPLY or a DC MAINS SUPPLY, it need not be marked with any electrical rating, such as its RATED VOLTAGE, RATED CURRENT or RATED FREQUENCY.

For equipment intended to be installed by an OPERATOR, the marking shall be readily visible in an OPERATOR ACCESS AREA, including any area that is directly visible only after an OPERATOR has opened a door or cover. If a manual voltage selector is not OPERATOR-accessible, the marking shall indicate the RATED VOLTAGE for which the equipment is set during manufacture; a temporary marker is permitted for this purpose. Marking is permitted on any outer surface of the equipment, except the bottom of equipment having a mass exceeding 18 kg. Additionally, on STATIONARY EQUIPMENT, the marking shall be visible after the equipment has been installed as in normal use.

For equipment intended to be installed by a SERVICE PERSON, and if the marking is in a SERVICE ACCESS AREA, the location of the permanent marking shall be indicated in the installation instructions or on a readily visible marker on the equipment. It is permitted to use a temporary marker for this purpose.

The marking shall include the following:

- RATED VOLTAGE(S) or RATED VOLTAGE RANGE(S), in volts;
 - the voltage range shall have a hyphen (-) between the minimum and maximum RATED VOLTAGES. When multiple RATED VOLTAGES or RATED VOLTAGE RANGES are given, they shall be separated by a solidus (/).

NOTE 1 Some examples of RATED VOLTAGE markings are:

- RATED VOLTAGE RANGE: 220-240 V. This means that the equipment is designed to be connected to an AC MAINS SUPPLY having any voltage between 220 V and 240 V.
- Multiple RATED VOLTAGE: 120/230/240 V. This means that the equipment is designed to be connected to an AC MAINS SUPPLY having a voltage of 120 V or 230 V or 240 V, usually after internal adjustment.
- if equipment is to be connected to both of the line conductors and to the neutral conductor of a single-phase, 3-wire power distribution system, the marking shall give the line-to-neutral voltage and the line-to-line voltage, separated by a solidus (/), with the added notation "Three wires plus protective earth", "3W + PE" or equivalent.

NOTE 2 Some examples of the above system rating markings are:

120/240 V; 3 wire + PE

120/240 V; 3W +  (60417-1-IEC-5019)

100/200 V; 2W + N + PE

- symbol for nature of supply, for d.c. only;
- RATED FREQUENCY or RATED FREQUENCY RANGE, in hertz, unless the equipment is designed for d.c. only;
- RATED CURRENT, in milliamperes or amperes;
 - for equipment with multiple RATED VOLTAGES, the corresponding RATED CURRENTS shall be marked such that the different current ratings are separated by a solidus (/) and the relation between RATED VOLTAGE and associated RATED CURRENT appears distinctly;
 - equipment with a RATED VOLTAGE RANGE shall be marked with either the maximum RATED CURRENT or with the current range;
 - the marking for RATED CURRENT of a group of units having a single supply connection shall be placed on the unit which is directly connected to an AC MAINS SUPPLY or a DC MAINS SUPPLY. The RATED CURRENT marked on that unit shall be the total maximum current that can be on circuit at the same time and shall include the combined currents to all units in the group that can be supplied simultaneously through the unit and that can be operated simultaneously.

NOTE 3 Some examples of RATED CURRENT markings are:

- for equipment with multiple RATED VOLTAGES;

120/240 V; 2,4/1,2 A

- for equipment with a RATED VOLTAGE RANGE;

100-240 V; 2,8 A

100-240 V; 2,8-1,4 A

100-120 V; 2,8 A

200-240 V; 1,4 A

It is recognized that in some regions it is customary to use a point (.) as a decimal marker instead of a comma.

- manufacturer's name or trade-mark or identification mark;
- manufacturer's model or type reference;
- symbol  (60417-1-IEC-5172), for CLASS II EQUIPMENT only.

Additional markings are permitted, provided that they do not give rise to misunderstanding.

Where symbols are used, they shall conform to ISO 7000 or IEC 60417-1 where appropriate symbols exist.

1.7.2 Safety instructions

Sufficient information shall be provided to the USER concerning any condition necessary to ensure that, when used as prescribed by the manufacturer, the equipment is unlikely to present a hazard within the meaning of this standard.

If it is necessary to take special precautions to avoid the introduction of hazards when operating, installing, servicing, transporting or storing equipment, the necessary instructions shall be made available.

NOTE 1 Special precautions may be necessary, for example, for connection of the equipment to the supply and for the interconnection of separate units, if any.

NOTE 2 Where appropriate, installation instructions should include reference to national wiring rules.

NOTE 3 Servicing instructions are normally made available only to SERVICE PERSONS.

NOTE 4 In Finland, Norway and Sweden, CLASS I PLUGGABLE EQUIPMENT TYPE A intended for connection to other equipment or a network, must, if safety relies on connection to protective earth or if surge suppressors are connected between the network terminals and accessible parts, have a marking stating that the equipment must be connected to an earthed mains socket-outlet.

The operating instructions, and the installation instructions for PLUGGABLE EQUIPMENT intended for USER installation, shall be made available to the USER.

Where the disconnect device is not incorporated in the equipment (see 3.4.3) or where the plug on the power supply cord is intended to serve as the disconnect device, the installation instructions shall state that:

- for PERMANENTLY CONNECTED EQUIPMENT, a readily accessible disconnect device shall be incorporated in the building installation wiring;
- for PLUGGABLE EQUIPMENT, the socket-outlet shall be installed near the equipment and shall be easily accessible.

For equipment that may produce ozone, the installation and operating instructions shall refer to the need to take precautions to ensure that the concentration of ozone is limited to a safe value.

NOTE 5 The present recommended long term exposure limit for ozone is 0,1 ppm (0,2 mg/m³) calculated as an 8 h time-weighted average concentration. It should be noted that ozone is heavier than air.

1.7.3 Short duty cycles

Equipment intended for SHORT-TIME OPERATION or for INTERMITTENT OPERATION shall be marked with RATED OPERATING TIME, or RATED OPERATING TIME and rated resting time respectively, unless the operating time is limited by the construction or by the definition of its NORMAL LOAD.

The marking of SHORT-TIME OPERATION or INTERMITTENT OPERATION shall correspond to normal use.

The marking of INTERMITTENT OPERATION shall be such that the RATED OPERATING TIME precedes the rated resting time, the two markings being separated by a solidus (/).

1.7.4 Supply voltage adjustment

For equipment intended for connection to multiple RATED VOLTAGES or FREQUENCIES, the method of adjustment shall be fully described in the servicing or installation instructions.

Unless the means of adjustment is a simple control near the power rating marking, and the setting of this control is obvious by inspection, the following instruction or a similar one shall appear in or near the power rating marking:

**SEE INSTALLATION INSTRUCTIONS
BEFORE CONNECTING TO THE SUPPLY**

1.7.5 Power outlets on the equipment

If any standard power supply outlet in the equipment is accessible to the OPERATOR, a marking shall be placed in the vicinity of the outlet to show the maximum load that is permitted to be connected to it.

Socket-outlets conforming to IEC 60083 are examples of standard power supply outlets.

1.7.6 Fuse identification

Marking shall be located adjacent to each fuse or fuseholder, or on the fuseholder, or in another location provided that it is obvious to which fuse the marking applies, giving the fuse current rating and, where fuses of different voltage rating value could be fitted, the fuse voltage rating.

Where fuses with special fusing characteristics such as time delay or breaking capacity are necessary, the type shall also be indicated.

For fuses not located in OPERATOR ACCESS AREAS and for soldered-in fuses located in OPERATOR ACCESS AREAS, it is permitted to provide an unambiguous cross-reference (for example, F1, F2, etc.) to the servicing instructions which shall contain the relevant information.

NOTE See 2.7.6 regarding other warnings to SERVICE PERSONS.

1.7.7 Wiring terminals

1.7.7.1 Protective earthing and bonding terminals

A wiring terminal intended for connection of a PROTECTIVE EARTHING CONDUCTOR shall be indicated by the symbol \oplus (60417-1-IEC-5019). This symbol shall not be used for other earthing terminals.

It is not a requirement to mark terminals for PROTECTIVE BONDING CONDUCTORS, but where such terminals are marked, the symbol \perp (60417-1-IEC-5017) shall be used.

The following situations are exempt from the above requirements:

- where terminals for the connection of a supply are provided on a component (for example, a terminal block) or subassembly (for example, a power supply unit), the symbol \perp is permitted for the protective earthing terminal instead of \oplus ;
- on subassemblies or components, the symbol \oplus is permitted in place of the symbol \perp provided that it does not give rise to confusion.

These symbols shall not be located on screws, or other parts which might be removed when conductors are being connected.

These requirements are applicable to terminals for connection of a PROTECTIVE EARTHING CONDUCTOR whether run as an integral part of a power supply cord or with supply conductors.

1.7.7.2 Terminals for a.c. mains supply conductors

For PERMANENTLY CONNECTED EQUIPMENT and equipment with ordinary NON-DETACHABLE POWER SUPPLY CORDS:

- terminals intended exclusively for connection of the AC MAINS SUPPLY neutral conductor, if any, shall be indicated by the capital letter N; and
- on three-phase equipment, if incorrect phase rotation could cause overheating or other hazard, terminals intended for connection of the AC MAINS SUPPLY line conductors shall be marked in such a way that, in conjunction with any installation instructions, the sequence of phase rotation is unambiguous.

These indications shall not be located on screws, or other parts which might be removed when conductors are being connected.

1.7.7.3 Terminals for d.c. mains supply conductors

For PERMANENTLY CONNECTED EQUIPMENT and equipment with ordinary NON-DETACHABLE POWER SUPPLY CORDS, terminals intended exclusively for connection of a DC MAINS SUPPLY shall be marked to indicate polarity.

If a single terminal is provided, both as a main protective earthing terminal in the equipment and for the connection to one pole of the DC MAINS SUPPLY, it shall be marked as specified in 1.7.7.1, in addition to polarity marking.

These indications shall not be located on screws or other parts which might be removed when conductors are being connected.

1.7.8 Controls and indicators

1.7.8.1 Identification, location and marking

Unless it is obviously unnecessary, indicators, switches and other controls affecting safety shall be identified or located so as to indicate clearly which function they control.

Markings and indications for switches and other controls shall be located either:

- on or adjacent to the switch or control, or
- elsewhere, provided that it is obvious to which switch or control the marking applies.

Indications used for this purpose shall, wherever practicable, be comprehensible without a knowledge of languages, national standards, etc.

1.7.8.2 Colours

Where safety is involved, colours of controls and indicators shall comply with IEC 60073. Where colours are used for functional controls or indicators, any colour, including red, is permitted provided that it is clear that safety is not involved.

1.7.8.3 Symbols

Where symbols are used on or near controls (for example, switches and push buttons) to indicate "ON" and "OFF" conditions, they shall be the line | for "ON" and circle ○ for "OFF" (60417-1-IEC-5007 and 60417-1-IEC-5008). For push-push type switches the symbol ① shall be used (60417-1-IEC-5010).

It is permitted to use the symbols ○ and | to indicate the "OFF" and "ON" positions of any primary or secondary power switches, including isolating switches.

A "STAND-BY" condition shall be indicated by the symbol  (60417-1-IEC-5009).

1.7.8.4 Markings using figures

If figures are used for indicating different positions of any control, the "OFF" position shall be indicated by the figure 0 (zero) and higher figures shall be used to indicate greater output, input, etc.

1.7.9 Isolation of multiple power sources

Where there is more than one connection supplying HAZARDOUS VOLTAGES or HAZARDOUS ENERGY LEVELS to equipment, a prominent marking, located close to the entry point provided for a SERVICE PERSON to gain access to the hazardous parts, shall be provided to indicate which disconnect device or devices isolate the equipment completely and which disconnect devices can be used to isolate each section of the equipment.

1.7.10 IT power distribution systems

If the equipment has been designed or, when required, modified for connection to an IT power distribution system, the equipment installation instructions shall so state.

1.7.11 Thermostats and other regulating devices

THERMOSTATS and similar regulating devices intended to be adjusted during installation or in normal use shall be provided with an indication for the direction of adjustment to increase or decrease the value of the characteristic being adjusted. Indication by the symbols + and – is permitted.

1.7.12 Language

Instructions and equipment marking related to safety shall be in a language which is acceptable in the country in which the equipment is to be installed.

NOTE 1 Documentation intended for use only by SERVICE PERSONS is permitted to be in the English language only.

NOTE 2 In Germany, safety related information also for SERVICE PERSONS has to be in the German language.

1.7.13 Durability

Any marking required by this standard shall be durable and legible. In considering the durability of the marking, the effect of normal use shall be taken into account.

Compliance is checked by inspection and by rubbing the marking by hand for 15 s with a piece of cloth soaked with water and again for 15 s with a piece of cloth soaked with petroleum spirit. After this test, the marking shall be legible; it shall not be possible to remove marking plates easily and they shall show no curling.

The petroleum spirit to be used for the test is aliphatic solvent hexane having a maximum aromatics content of 0,1 % by volume, a kauributenol value of 29, an initial boiling point of approximately 65 °C, a dry point of approximately 69 °C and a mass per unit volume of approximately 0,7 kg/l.

1.7.14 Removable parts

Marking required by this standard shall not be placed on removable parts which can be replaced in such a way that the marking would become misleading.

1.7.15 Replaceable batteries

If an equipment is provided with a replaceable battery, and if replacement by an incorrect type could result in an explosion (for example, with some lithium batteries), the following applies:

- if the battery is placed in an OPERATOR ACCESS AREA, there shall be a marking close to the battery or a statement in both the operating and the servicing instructions;
- if the battery is placed elsewhere in the equipment, there shall be a marking close to the battery or a statement in the servicing instructions.

This marking or statement shall include the following or similar text:

CAUTION
RISK OF EXPLOSION IF BATTERY IS REPLACED
BY AN INCORRECT TYPE.
DISPOSE OF USED BATTERIES ACCORDING
TO THE INSTRUCTIONS

1.7.16 Operator access with a tool

If a TOOL is necessary to gain access to an OPERATOR ACCESS AREA, either all other compartments within that area containing a hazard shall be inaccessible to the OPERATOR by the use of the same TOOL, or such compartments shall be marked to discourage OPERATOR access.

An acceptable marking for an electric shock hazard is  (ISO 3864, No. 5036).

1.7.17 Equipment for restricted access locations

For equipment intended only for installation in a RESTRICTED ACCESS LOCATION, the installation instructions shall contain a statement to this effect.

2 Protection from hazards

2.1 Protection from electric shock and energy hazards

NOTE In Australia, additional requirements apply.

2.1.1 Protection in operator access areas

This subclause specifies requirements for protection against electric shock from energized parts based on the principle that the OPERATOR is permitted to have access to:

- bare parts of SELV CIRCUITS; and
- bare parts of LIMITED CURRENT CIRCUITS; and
- TNV CIRCUITS under the conditions specified in 2.1.1.1.

Access to other energized parts, and to their insulation, is restricted as specified in 2.1.1.1.

Additional requirements are specified in 2.1.1.5 for protection against energy hazards.

2.1.1.1 Access to energized parts

The equipment shall be so constructed that in OPERATOR ACCESS AREAS there is adequate protection against contact with:

- bare parts of ELV CIRCUITS; and
- bare parts at HAZARDOUS VOLTAGES; and
- FUNCTIONAL INSULATION or BASIC INSULATION of parts or wiring in ELV CIRCUITS, except as permitted in 2.1.1.3; and
- FUNCTIONAL INSULATION or BASIC INSULATION of parts or wiring at HAZARDOUS VOLTAGES; and

NOTE 1 FUNCTIONAL INSULATION includes, but is not limited to, insulation, such as lacquer, solvent-based enamel, ordinary paper, cotton and oxide film, or displaceable insulation such as beads and sealing compounds other than self-hardening resin.

- unearthed conductive parts separated from ELV CIRCUITS or from parts at HAZARDOUS VOLTAGES by FUNCTIONAL INSULATION or BASIC INSULATION only; and
- bare parts of TNV CIRCUITS, except that access is permitted to:
 - contacts of connectors which cannot be touched by the test probe (figure 2C);
 - bare conductive parts in the interior of a battery compartment that complies with 2.1.1.2;
 - bare conductive parts of TNV-1 CIRCUITS that have any point connected in accordance with 2.6.1 e) to a protective earthing terminal;
 - bare conductive parts of connectors in TNV-1 CIRCUITS that are separated from unearthed accessible conductive parts of the equipment in accordance with 6.2.1.

NOTE 2 A typical application is the shell for a coaxial connector.

NOTE 3 Access to TNV-1 CIRCUITS and TNV-3 CIRCUITS via other circuits is also restricted by 6.2.1 in some cases.

Unrestricted access is permitted to LIMITED CURRENT CIRCUITS.

These requirements apply for all positions of the equipment when it is wired and operated as in normal use.

Protection shall be achieved by insulation or by guarding or by the use of interlocks.

Compliance is checked by all of the following.

- a) *Inspection.*
- b) *A test with the test finger, figure 2A, which shall not contact parts described above when applied to openings in the ENCLOSURES after removal of parts that can be detached by an OPERATOR, including fuseholders, and with OPERATOR access doors and covers open. It is permitted to leave lamps in place for this test. Connectors that can be separated by an OPERATOR, other than plugs and socket-outlets complying with IEC 60083, shall also be tested during disconnection.*
- c) *A test with the test pin, figure 2B, which shall not contact bare parts at HAZARDOUS VOLTAGES when applied to openings in an external ELECTRICAL ENCLOSURE. Parts that can be detached by an OPERATOR, including fuseholders and lamps, are left in place, and OPERATOR access doors and covers are closed during this test.*
- d) *A test with the test probe, figure 2C, where appropriate.*

The test finger, the test pin and the test probe are applied as above, without appreciable force, in every possible position, except that floor-standing equipment having a mass exceeding 40 kg is not tilted.

Equipment intended for building-in or rack-mounting, or for incorporation in larger equipment, is tested with access to the equipment limited according to the method of mounting detailed in the installation instructions.

Openings preventing the entry of the test finger, test b) above, are further tested by means of a straight unjointed version of the test finger applied with a force of 30 N. If the unjointed finger enters, test b) is repeated except that the finger is pushed through the opening using any necessary force up to 30 N.

NOTE 4 If an electrical contact indicator is used to show contact, care should be taken to ensure that the application of the test does not damage components of electronic circuits.

The above requirements regarding contact with parts at HAZARDOUS VOLTAGE apply only to HAZARDOUS VOLTAGES not exceeding 1 000 V a.c. or 1 500 V d.c. For higher voltages, contact is not permitted, and there shall be an air gap between the part at HAZARDOUS VOLTAGE and the test finger, figure 2A, or the test pin, figure 2B, placed in its most unfavourable position. This air gap shall either have a minimum length equal to the minimum CLEARANCE for BASIC INSULATION specified in 2.10.3 or shall withstand the relevant electric strength test in 5.2.2. (See figure F.12, point A.)

If components are movable, for instance, for the purpose of belt tensioning, the test with the test finger is made with each component in its most unfavourable position within the range of adjustment, the belt being removed, if necessary, for this purpose.

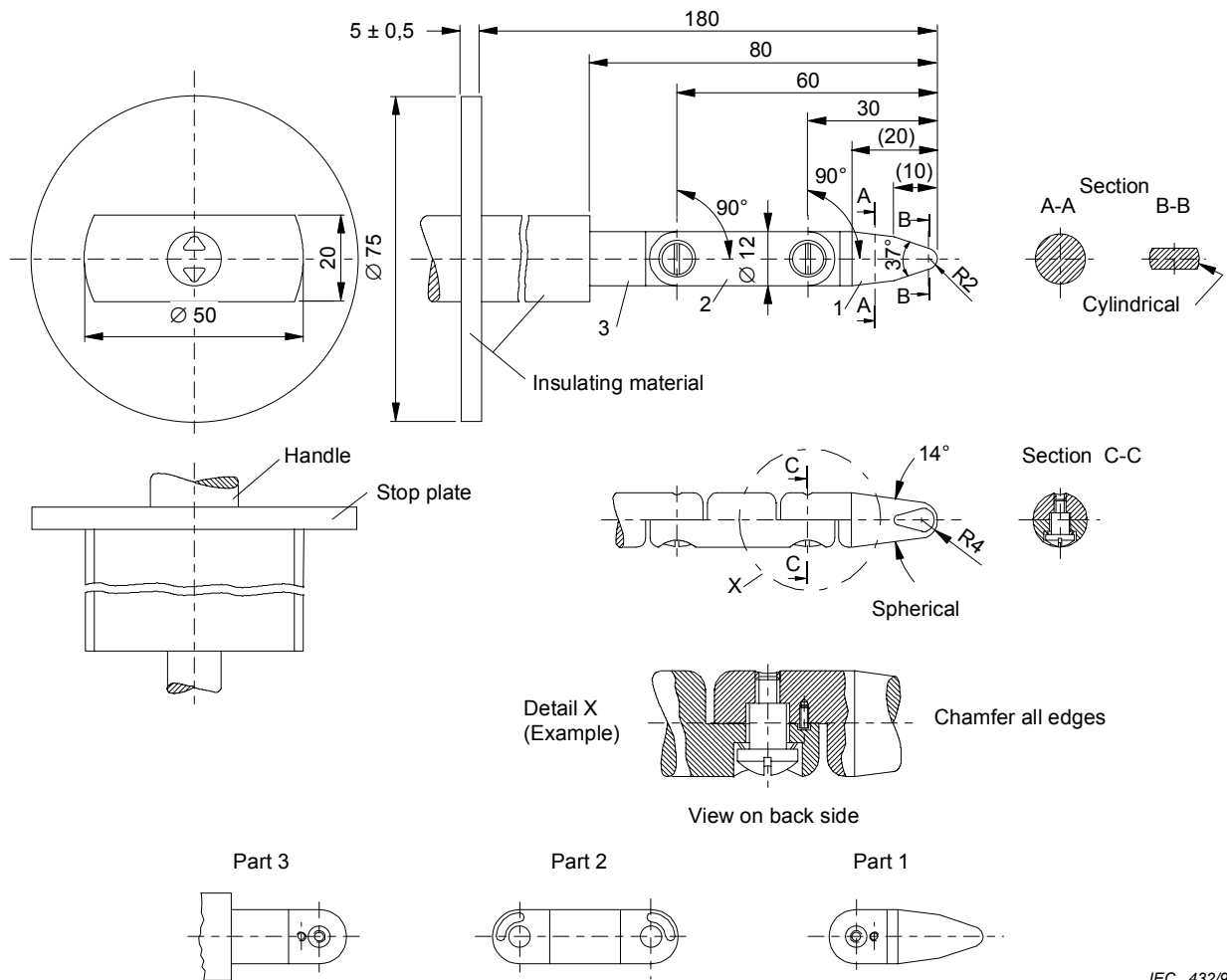

IEC 432/99

Linear dimensions in millimetres

Tolerances on dimensions without specific tolerances:

- 14° and 37° angles: $\pm 15'$
- on radii: $\pm 0,1$ mm
- on linear dimensions:
 - ≤ 15 mm: $\begin{matrix} 0 \\ -0,1 \end{matrix}$ mm
 - > 15 mm ≤ 25 mm: $\pm 0,1$ mm
 - > 25 mm: $\pm 0,3$ mm

Material of finger: heat-treated steel, for example.

Both joints of this finger can be bent through an angle of $90^\circ \begin{matrix} +10^\circ \\ 0 \end{matrix}$ but in one and the same direction only.

NOTE 1 Using the pin and groove solution is only one of the possible approaches in order to limit the bending angle to 90° . For this reason, dimensions and tolerances of these details are not given in the drawing. The actual design must insure a 90° bending angle with a 0° to $+10^\circ$ tolerance.

NOTE 2 Dimensions in parentheses are for information only.

NOTE 3 The test finger is taken from IEC 61032, figure 2, test probe B. In some cases, the tolerances are different.

Figure 2A – Test finger

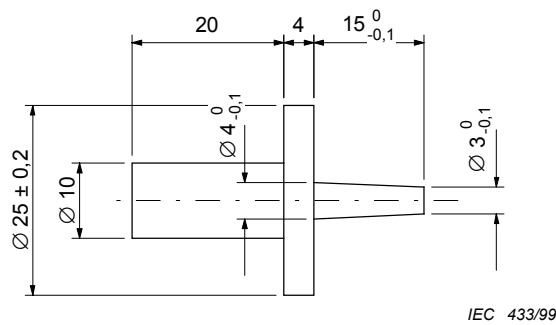

Dimensions in millimetres

The handle dimensions (\varnothing 10 and 20) are not critical.

NOTE The test pin dimensions are those given in IEC 61032, figure 8, test probe 13. In some cases the tolerances are different.

Figure 2B – Test pin

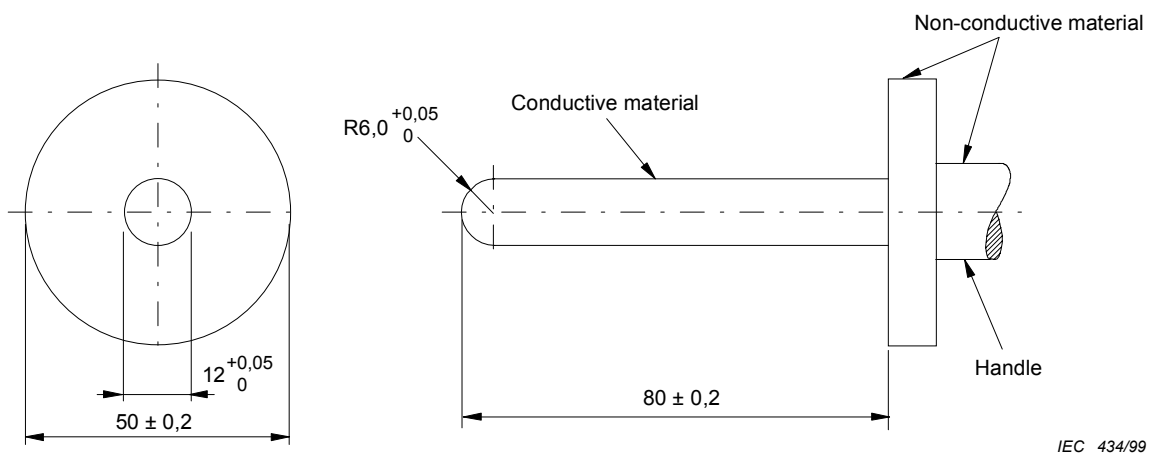

Dimensions in millimetres

Figure 2C – Test probe

2.1.1.2 Battery compartments

Access to bare conductive parts of TNV CIRCUITS within a battery compartment in the equipment is permitted if all of the following conditions are met:

- the compartment has a door that requires a deliberate technique to open, such as the use of a TOOL or latching device; and
- the TNV CIRCUIT is not accessible when the door is closed; and
- there is a marking next to the door, or on the door if the door is secured to the equipment, with instructions for protection of the USER once the door is opened.

NOTE Information stating that the telephone cord is to be disconnected prior to opening the door is an example of an acceptable instruction.

Compliance is checked by inspection.

2.1.1.3 Access to ELV wiring

Insulation of internal wiring in an ELV CIRCUIT is permitted to be accessible to an OPERATOR provided that:

- a) the insulation meets the requirements for SUPPLEMENTARY INSULATION detailed in 3.1.4; or
- b) all of the following apply:
 - the wiring does not need to be handled by the OPERATOR and is so placed that the OPERATOR is unlikely to pull on it, or is so fixed that the connecting points are relieved from strain; and
 - the wiring is routed and fixed so as not to touch unearthed accessible conductive parts; and
 - the insulation passes the electric strength test of 5.2.2 for SUPPLEMENTARY INSULATION; and
 - the distance through the insulation is not less than that given in table 2A.

Table 2A – Distance through insulation of internal wiring

WORKING VOLTAGE (in case of failure of BASIC INSULATION)		Minimum distance through insulation mm
V peak or d.c.	V r.m.s. (sinusoidal)	
Over 71, up to 350	Over 50, up to 250	0,17
Over 350	Over 250	0,31

Compliance is checked by inspection and measurement, and by the test of 5.2.2.

2.1.1.4 Access to hazardous voltage circuit wiring

Where the insulation of internal wiring at HAZARDOUS VOLTAGE is accessible to an OPERATOR, or is not routed and fixed to prevent it from touching unearthed accessible conductive parts, it shall meet the requirements of 3.1.4 for DOUBLE INSULATION or REINFORCED INSULATION.

Compliance is checked by inspection and measurement and, if necessary, by test.

2.1.1.5 Energy hazards

There shall be no risk of injury due to an energy hazard in an OPERATOR ACCESS AREA.

Compliance is checked by inspection and measurement and, if necessary, by tests.

- a) *A risk of injury due to an energy hazard exists if it is likely that two or more bare parts (one of which may be earthed) between which a HAZARDOUS ENERGY LEVEL exists, will be bridged by a metallic object.*
- b) *The likelihood of bridging the parts under consideration is determined by means of the test finger, figure 2A (see 2.1.1.1), in a straight position. It shall not be possible to bridge the parts with this test finger, applied without appreciable force.*
- c) *The existence of a HAZARDOUS ENERGY LEVEL is determined as follows:*

- 1) *with the equipment operating under normal operating conditions, a variable resistive load is connected to the parts under consideration and adjusted to obtain a level of 240 VA. Further adjustment is made, if necessary, to maintain 240 VA for a period of 60 s. If the voltage is 2 V or more, the output power is at a HAZARDOUS ENERGY LEVEL, unless an overcurrent protective device opens during the above test, or for any other reason the power cannot be maintained at 240 VA for 60 s;*
- 2) *the stored energy in a capacitor is at a HAZARDOUS ENERGY LEVEL if the voltage, U, is 2 V or more, and the stored energy, E, calculated from the following equation, exceeds 20 J:*

$$E = 0,5 CU^2 \times 10^{-6}$$

where

E is the energy, in joules (J);

C is the capacitance, in microfarads (μF);

U is the measured voltage on the capacitor, in volts (V).

2.1.1.6 Manual controls

Conductive shafts of operating knobs, handles, levers and the like shall not be connected to parts at HAZARDOUS VOLTAGES, to ELV CIRCUITS or to TNV CIRCUITS.

In addition, conductive operating knobs, handles, levers and the like which are manually moved in normal use and which are earthed only through a pivot or bearing, shall either:

- be separated from parts at HAZARDOUS VOLTAGES by DOUBLE INSULATION or REINFORCED INSULATION; or
- have their accessible parts covered by SUPPLEMENTARY INSULATION.

Compliance is checked by inspection.

2.1.1.7 Discharge of capacitors in equipment

Equipment shall be so designed that, at an external point of disconnection of an AC MAINS SUPPLY or a DC MAINS SUPPLY, the risk of electric shock from stored charge on capacitors connected in the equipment is reduced.

Compliance is checked by inspection of the equipment and relevant circuit diagrams, taking into account the possibility of disconnection of the supply with the "ON"/"OFF" switch in either position.

Equipment is considered to comply if any capacitor having a marked or nominal capacitance exceeding 0,1 μF and in circuits connected to the AC MAINS SUPPLY or the DC MAINS SUPPLY has a means of discharge resulting in a time constant not exceeding:

- 1 s for PLUGGABLE EQUIPMENT TYPE A; and
- 10 s for PERMANENTLY CONNECTED EQUIPMENT and for PLUGGABLE EQUIPMENT TYPE B.

The relevant time constant is the product of the effective capacitance in microfarads and the effective discharge resistance in megohms. If it is difficult to determine the effective capacitance and resistance values, a measurement of voltage decay at the point of external disconnection can be used.

NOTE During an interval equal to one time constant, the voltage will have decayed to 37 % of its original value.

2.1.2 Protection in service access areas

In a SERVICE ACCESS AREA, the following requirements apply.

Bare parts at HAZARDOUS VOLTAGES shall be located or guarded so that unintentional contact with such parts is unlikely during service operations involving other parts of the equipment.

Bare parts at HAZARDOUS VOLTAGE shall be located or guarded so that accidental shorting to SELV CIRCUITS or to TNV CIRCUITS (for example, by TOOLS or test probes used by a SERVICE PERSON) is unlikely.

No requirement is specified regarding access to ELV CIRCUITS or to TNV CIRCUITS. However, bare parts that present a HAZARDOUS ENERGY LEVEL shall be located or guarded so that unintentional bridging by conductive materials that might be present is unlikely during service operations involving other parts of the equipment.

Any guards required for compliance with 2.1.2 shall be easily removable and replaceable if removal is necessary for servicing.

Compliance is checked by inspection and measurement. In deciding whether or not unintentional contact is likely, account is taken of the way a SERVICE PERSON needs to gain access past, or near to, the bare parts in order to service other parts. For determination of a HAZARDOUS ENERGY LEVEL see 2.1.1.5 c).

2.1.3 Protection in restricted access locations

For equipment to be installed in a RESTRICTED ACCESS LOCATION, the requirements for OPERATOR ACCESS AREAS apply, except as permitted in the following three paragraphs.

If a SECONDARY CIRCUIT at HAZARDOUS VOLTAGE is used to supply a ringing signal generator that complies with 2.3.1 b), contact with bare parts of the circuit is permitted with the test finger, figure 2A (see 2.1.1.1). However, such parts shall be so located or guarded that unintentional contact is unlikely.

Bare parts that present a HAZARDOUS ENERGY LEVEL shall be located or guarded so that unintentional bridging by conductive materials that might be present is unlikely.

No requirement is specified regarding contact with bare parts of TNV-1, TNV-2 and TNV-3 CIRCUITS.

Compliance is checked by inspection and measurement. In deciding whether or not unintentional contact is likely, account is taken of the need to gain access past, or near to, the bare parts. For determination of a HAZARDOUS ENERGY LEVEL see 2.1.1.5 c).

2.2 SELV circuits

2.2.1 General requirements

SELV CIRCUITS shall exhibit voltages that are safe to touch both under normal operating conditions and after a single fault (see 1.4.14). If no external load is applied to the SELV CIRCUIT (open circuit), the voltage limits of 2.2.2 and 2.2.3 shall not be exceeded.

Compliance with 2.2.1 to 2.2.4 is checked by inspection and relevant tests.

2.2.2 Voltages under normal conditions

In a single SELV CIRCUIT or in interconnected SELV CIRCUITS, the voltage between any two conductors of the SELV CIRCUIT or CIRCUITS, and between any one such conductor and earth (see 1.4.9), shall not exceed 42,4 V peak, or 60 V d.c., under normal operating conditions.

NOTE A circuit that meets the above requirements, but that is subject to overvoltages from a TELECOMMUNICATION NETWORK or a CABLE DISTRIBUTION SYSTEM, is a TNV-1 CIRCUIT.

2.2.3 Voltages under fault conditions

Except as permitted in 2.3.2, in the event of a single fault (see 1.4.14), the voltages between any two conductors of the SELV CIRCUIT or CIRCUITS and between any one such conductor and earth (see 1.4.9) shall not exceed 42,4 V peak, or 60 V d.c., for longer than 0,2 s. Moreover, a limit of 71 V peak, or 120 V d.c., shall not be exceeded.

NOTE In Canada and the United States, the exception mentioned in 2.3.2 is not permitted.

Except as permitted in 2.2.4, one of the methods specified in 2.2.3.1, 2.2.3.2, or 2.2.3.3 shall be used.

It is permitted for some parts of a circuit (for example, a transformer-rectifier circuit) to comply with all of the requirements for SELV CIRCUITS and to be OPERATOR-accessible, while other parts of the same circuit do not comply with all of the requirements for SELV CIRCUITS and are therefore not permitted to be OPERATOR-accessible.

2.2.3.1 Separation by double insulation or reinforced insulation (Method 1)

Where an SELV CIRCUIT is separated from other circuits by DOUBLE INSULATION or REINFORCED INSULATION only, one of the following constructions shall be used:

- provide permanent separation by barriers, routing or fixing; or
- provide insulation of all adjacent wiring involved that is rated for the highest WORKING VOLTAGE present; or
- provide insulation on either the wiring of the SELV CIRCUIT or that of the other circuits that meets the insulation requirements for SUPPLEMENTARY INSULATION or REINFORCED INSULATION, as appropriate, for the highest WORKING VOLTAGE present; or
- provide an additional layer of insulation, where required, over either the wiring of the SELV CIRCUIT or that of the other circuits; or
- provide two separate transformers in tandem, where one transformer provides BASIC INSULATION and the other transformer provides SUPPLEMENTARY INSULATION; or
- use any other means providing equivalent insulation.

2.2.3.2 Separation by earthed screen (Method 2)

Where SELV CIRCUITS are separated from parts at HAZARDOUS VOLTAGE by an earthed screen or other earthed conductive parts, the parts at HAZARDOUS VOLTAGE shall be separated from the earthed parts by BASIC INSULATION. The earthed parts shall comply with 2.6.

2.2.3.3 Protection by earthing of the SELV circuit (Method 3)

Parts of SELV CIRCUITS protected by earthing shall be connected to a protective earthing terminal in such a way that the requirements of 2.2.3 are met by relative circuit impedances or by the operation of a protective device or both. Except as permitted in 2.3.2, parts of SELV CIRCUITS shall also be separated from parts of non-SELV CIRCUITS by BASIC INSULATION. The SELV CIRCUIT shall have adequate fault current-carrying capacity to ensure operation of the protective device, if any, and to assure the integrity of the fault current path to earth. The earthed parts shall comply with 2.6.1 b).

NOTE 1 Different parts of the same SELV CIRCUIT may be protected by different methods, for example:

- Method 2 within a power transformer feeding a bridge rectifier; and
- Method 1 for the a.c. SECONDARY CIRCUIT; and
- Method 3 at the output of the bridge rectifier.

NOTE 2 For normal conditions the SELV CIRCUIT voltage limit is the same for an ELV CIRCUIT; an SELV CIRCUIT may be regarded as an ELV CIRCUIT with additional protection under fault conditions.

2.2.4 Connection of SELV circuits to other circuits

An SELV CIRCUIT is permitted to be connected to other circuits provided that, when the SELV CIRCUIT is so connected, all of the following conditions are met:

- except as permitted by 1.5.7 and 2.4.3, the SELV CIRCUIT is separated by BASIC INSULATION from any PRIMARY CIRCUIT (including the neutral) within the equipment; and
- the SELV CIRCUIT meets the limits of 2.2.2 under normal operating conditions; and
- except as specified in 2.3.2, the SELV CIRCUIT meets the limits of 2.2.3 in the event of a single fault (see 1.4.14) in the SELV CIRCUIT or in the SECONDARY CIRCUIT to which the SELV CIRCUIT is connected.

If an SELV CIRCUIT is connected to one or more other circuits, the SELV CIRCUIT is that part which complies with the requirements of 2.2.2 and 2.2.3.

If an SELV CIRCUIT obtains its supply conductively from a SECONDARY CIRCUIT which is separated from a HAZARDOUS VOLTAGE circuit by either:

- DOUBLE INSULATION or REINFORCED INSULATION; or
- an earthed conductive screen that is separated from the HAZARDOUS VOLTAGE circuit by BASIC INSULATION;

the SELV CIRCUIT shall be considered as being separated from the HAZARDOUS VOLTAGE circuit by the same method.

NOTE For requirements in Norway, see 1.7.2, note 4 and the note to 6.1.2.1.

If an SELV CIRCUIT is derived from a HAZARDOUS VOLTAGE SECONDARY CIRCUIT, and the HAZARDOUS VOLTAGE SECONDARY CIRCUIT is separated from the PRIMARY CIRCUIT by DOUBLE INSULATION or REINFORCED INSULATION, the SELV CIRCUIT shall remain within the limits given in 2.2.3 under single fault conditions (see 1.4.14). In such a case, the short circuiting of the insulation in a transformer that provides the separation between the HAZARDOUS VOLTAGE SECONDARY CIRCUIT and the SELV CIRCUIT is considered to be a single fault, for the purpose of applying the single fault conditions, provided the insulation in the transformer passes an electrical strength test for BASIC INSULATION in accordance with 5.2.2, based on the WORKING VOLTAGE involved.

2.3 TNV circuits

2.3.1 Limits

In a single TNV CIRCUIT or interconnected TNV CIRCUITS, the voltage between any two conductors of the TNV CIRCUIT or CIRCUITS and between any one such conductor and earth (see 1.4.9) shall comply with the following.

a) TNV-1 CIRCUITS

The voltages do not exceed the following:

- the voltage limits in 2.2.2 for an SELV CIRCUIT under normal operating conditions;
- the voltage limits of figure 2D measured across a $5\,000\ \Omega \pm 2\%$ resistor in the event of a single fault (see 1.4.14) within the equipment.

NOTE 1 In the event of a single insulation or component failure, the limit after 200 ms is the limit in 2.3.1 b) for a TNV-2 or TNV-3 CIRCUIT for normal operating conditions.

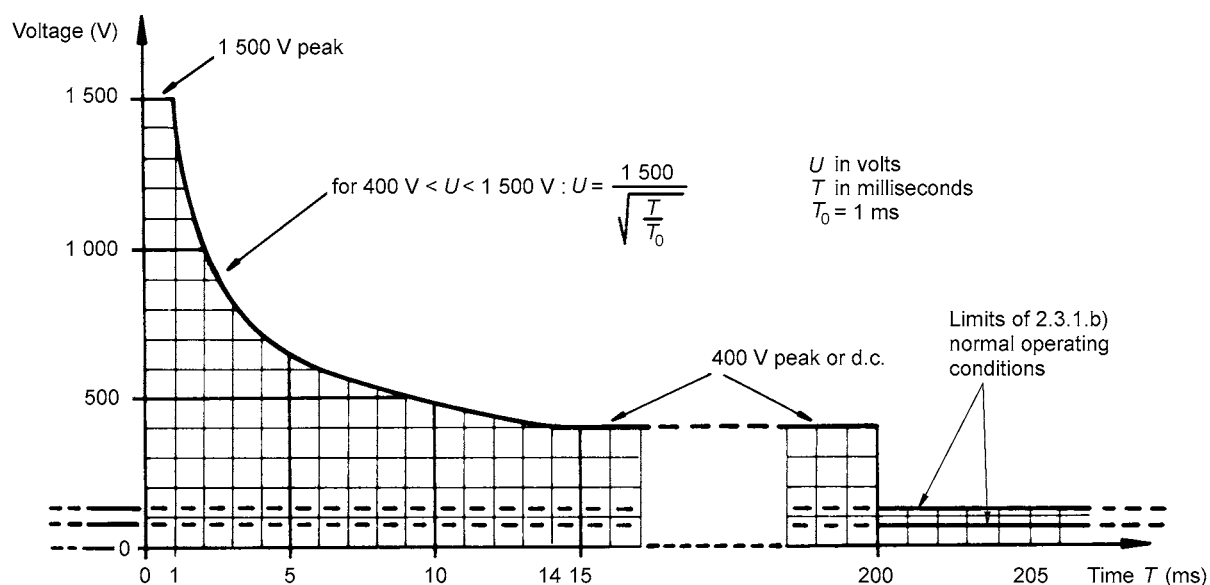

Figure 2D – Maximum voltages permitted after a single fault

b) TNV-2 CIRCUITS and TNV-3 CIRCUITS

The voltages exceed the limits in 2.2.2 for an SELV CIRCUIT but do not exceed the following:

- when telephone ringing signals are present, voltages such that the signal complies with the criteria of either clause M.2 or clause M.3;
- when telephone ringing signals are not present;
 - a combination of a.c. voltage and DC VOLTAGE under normal operating conditions such that:

$$\frac{U_{ac}}{71} + \frac{U_{dc}}{120} \leq 1$$

where

U_{ac} is the peak value of the a.c. voltage (V) at any frequency;

U_{dc} is the value of the DC VOLTAGE (V).

NOTE 2 When U_{dc} is zero, U_{ac} can be up to 71 V peak.

NOTE 3 When U_{ac} is zero, U_{dc} can be up to 120 V.

and

- the voltage limits of figure 2D measured across a $5\,000\ \Omega \pm 2\%$ resistor in the event of a single fault (see 1.4.14) within the equipment.

Compliance is checked by inspection and measurement.

NOTE 4 Telegraph and teletypewriter signals may be present on existing TELECOMMUNICATION NETWORKS. However, these signals are considered to be obsolescent and their characteristics are not considered in this standard.

2.3.2 Separation from other circuits and from accessible parts

NOTE 1 See also 6.1.2 and 6.2.

Separation of SELV CIRCUITS, TNV-1 CIRCUITS and accessible conductive parts from TNV-2 CIRCUITS and TNV-3 CIRCUITS shall be such that in the event of a single fault (see 1.4.14), the voltage limits specified in 2.3.1 b) for TNV-2 CIRCUITS and TNV-3 CIRCUITS under normal operating conditions are not exceeded on the SELV CIRCUITS and accessible conductive parts. In the event of a single fault (see 1.4.14), the voltages of TNV-1 CIRCUITS are permitted to rise to the limits of figure 2D.

NOTE 2 In Canada and the United States, in the event of a single fault as described above, the limits of 2.2.3 apply.

NOTE 3 Under normal operating conditions, the limits of 2.2.2 always apply to each SELV CIRCUIT and accessible conductive part.

NOTE 4 The limits of 2.3.1 always apply to each TNV CIRCUIT.

The separation requirements will be met if BASIC INSULATION is provided as indicated in table 2G (see 2.9.3), other solutions are not excluded.

BASIC INSULATION is not required provided that all of the following are met:

- the SELV CIRCUIT, TNV-1 CIRCUIT or accessible conductive part shall be connected to a protective earthing terminal in accordance with 2.6; and

- for PLUGGABLE EQUIPMENT TYPE A, a separate protective earthing terminal shall be provided in addition to the main protective earthing terminal, if any (see 2.6.4.1). The installation instructions shall specify that this separate protective earthing terminal be permanently connected to earth; and
- for PLUGGABLE EQUIPMENT TYPE B, the equipment shall either comply with the above requirements for PLUGGABLE EQUIPMENT TYPE A or be provided with both a marking on the equipment and a statement in the installation instructions, specifying that the USER is to disconnect all TELECOMMUNICATION NETWORK connectors and all CABLE DISTRIBUTION SYSTEM connectors before disconnecting the power; and

NOTE 5 PERMANENTLY CONNECTED EQUIPMENT is assumed to have the main protective earthing terminal permanently connected to earth.

- the test of 2.3.5 shall be carried out if the TNV-2 CIRCUIT or TNV-3 CIRCUIT is intended to receive signals or power that are generated externally during normal operation (for example, in a TELECOMMUNICATION NETWORK).

At the choice of the manufacturer, it is permitted to treat a TNV-1 CIRCUIT or a TNV-2 CIRCUIT as a TNV-3 CIRCUIT. In this case, the TNV-1 CIRCUIT or TNV-2 CIRCUIT shall meet all the separation requirements for a TNV-3 CIRCUIT.

Compliance is checked by inspection and measurement and, where necessary, by simulation of failures of components and insulation such as are likely to occur in the equipment. Prior to the tests, insulation that does not meet the requirements for BASIC INSULATION is short-circuited.

NOTE 6 Where BASIC INSULATION is provided and 6.2.1 also applies to this insulation, the test voltage prescribed in 6.2.2 is in most cases higher than that for BASIC INSULATION.

NOTE 7 For requirements in Finland, Norway and Sweden see the note to 6.1.2.1.

NOTE 8 In Denmark, the insulation between TNV CIRCUITS and any part or circuit connected to earth shall withstand an electric strength test of 500 V a.c. r.m.s. for 1 min.

2.3.3 Separation from hazardous voltages

Except as permitted in 2.3.4, TNV CIRCUITS shall be separated from circuits at HAZARDOUS VOLTAGES by one or both of the following methods.

- a) DOUBLE INSULATION or REINFORCED INSULATION.
- b) BASIC INSULATION, together with protective screening connected to the protective earthing terminal.

Compliance is checked by inspection and measurement.

NOTE 1 In Denmark and Finland, method b) is permitted only for PERMANENTLY CONNECTED EQUIPMENT or for PLUGGABLE EQUIPMENT TYPE B.

NOTE 2 For requirements in Norway, see 1.7.2, note 4 and the note to 6.1.2.1.

2.3.4 Connection of TNV circuits to other circuits

Except as permitted in 1.5.7, a TNV CIRCUIT is permitted to be connected to other circuits, provided that it is separated by BASIC INSULATION from any PRIMARY CIRCUIT (including the neutral) within the equipment.

NOTE 1 The limits of 2.3.1 always apply to TNV CIRCUITS.

If a TNV CIRCUIT is connected to one or more other circuits, the TNV CIRCUIT is that part which complies with 2.3.1.

If a TNV CIRCUIT obtains its supply conductively from a SECONDARY CIRCUIT which is separated from a HAZARDOUS VOLTAGE circuit by:

- DOUBLE INSULATION or REINFORCED INSULATION; or
- the use of an earthed conductive screen that is separated from a HAZARDOUS VOLTAGE circuit by BASIC INSULATION;

the TNV CIRCUIT shall be considered as being separated from the HAZARDOUS VOLTAGE circuit by the same method.

If a TNV CIRCUIT is derived from a HAZARDOUS VOLTAGE SECONDARY CIRCUIT, and the HAZARDOUS VOLTAGE SECONDARY CIRCUIT is separated from the PRIMARY CIRCUIT by DOUBLE INSULATION or REINFORCED INSULATION, the TNV CIRCUIT shall remain within the limits given in 2.3.1 under single fault conditions (see 1.4.14). In such a case, the short circuiting of the insulation in a transformer that provides the separation between the HAZARDOUS VOLTAGE SECONDARY CIRCUIT and the TNV CIRCUIT is considered to be a single fault, for the purpose of applying the single fault conditions, provided the insulation in the transformer passes an electrical strength test for BASIC INSULATION in accordance with 5.2.2, based on the WORKING VOLTAGE involved.

Compliance is checked by inspection, and by simulation of single faults (see 1.4.14) such as are likely to occur in the equipment. No such simulated fault shall cause the voltage across a $5\,000\ \Omega \pm 2\%$ resistor, connected between any two conductors of the TNV CIRCUIT or between one such conductor and earth, to fall outside the shaded area of figure 2D (see 2.3.1). Observation is continued until stable conditions have existed for at least 5 s.

NOTE 2 For requirements in Norway, see 1.7.2, note 4 and the note to 6.1.2.1.

NOTE 3 For requirements in Finland, see 2.3.3, note 1.

2.3.5 Test for operating voltages generated externally

This test is only carried out if specified in 2.3.2.

A test generator specified by the manufacturer is used, representing the maximum normal operating voltage expected to be received from the external source. In the absence of such a specification, a test generator is used that provides $120\ \text{V} \pm 2\ \text{V a.c.}$ at 50 Hz or 60 Hz and has an internal impedance of $1\,200\ \Omega \pm 2\%$.

NOTE The above test generator is not intended to represent the actual voltages on the TELECOMMUNICATION NETWORK but to stress the circuit of the EUT in a repeatable manner.

The test generator is connected between the TELECOMMUNICATION NETWORK terminals of the equipment. One pole of the test generator is also connected to the earthing terminal of the equipment, see figure 2E. The test voltage is applied for a maximum of 30 min. If it is clear that no further deterioration will take place, the test is terminated earlier.

During the test, the SELV CIRCUIT, TNV-1 CIRCUIT or accessible conductive part shall continue to comply with 2.2.2.

The test is repeated after reversing the connections to the TELECOMMUNICATION NETWORK terminals of the equipment.

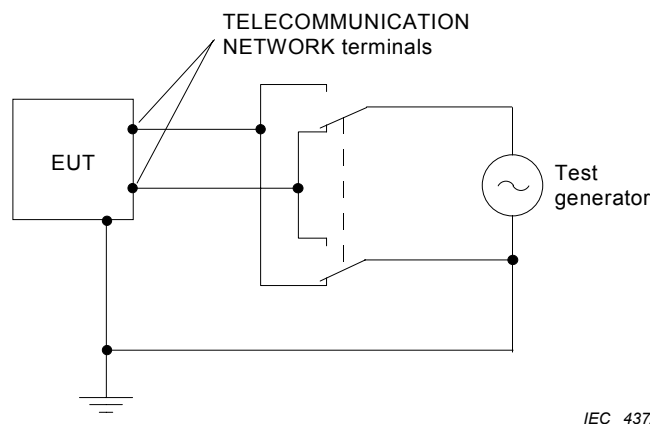

Figure 2E – Test generator

2.4 Limited current circuits

2.4.1 General requirements

LIMITED CURRENT CIRCUITS shall be so designed that the limits specified in 2.4.2 are not exceeded under normal operating conditions and in the event of a single failure within the equipment (see 1.4.14 and 1.5.7).

Except as permitted in 2.4.3, segregation of accessible parts of LIMITED CURRENT CIRCUITS from other circuits shall be as described in 2.2 for SELV CIRCUITS.

Compliance is checked by inspection and measurement.

2.4.2 Limit values

For frequencies not exceeding 1 kHz, the steady-state current drawn through a non-inductive resistor of $2\,000\ \Omega \pm 10\%$ connected between any two parts of a LIMITED CURRENT CIRCUIT, or between any such part and earth (see 1.4.9), shall not exceed 0,7 mA peak, or 2 mA d.c.

For frequencies above 1 kHz, the limit of 0,7 mA is multiplied by the value of the frequency in kilohertz but shall not exceed 70 mA peak.

Alternatively, it is permitted to use the measuring instruments of annex D instead of the non-inductive resistor of $2\,000\ \Omega \pm 10\%$ mentioned above.

When using the measuring instrument of figure D.1, the voltage, U_2 , is measured and the current is calculated by dividing the measured voltage, U_2 , by 500. The calculated value shall not exceed 0,7 mA peak.

NOTE 1 If one side of the LIMITED CURRENT CIRCUIT has a conductive connection to earth, point B of the measuring instrument of figure D.1 should be connected to that side.

When using the measuring instrument of figure D.2, the measured value of the current shall not exceed 0,7 mA peak.

For parts not exceeding 450 V peak or d.c., the circuit capacitance shall not exceed 0,1 μF .

For parts whose voltage, U , exceeds 0,45 kV peak or d.c., but does not exceed 15 kV peak or d.c., the circuit capacitance shall not exceed $45/U$ nF, where U is expressed in kilovolts.

NOTE 2 The limit of $45/U$ corresponds to an available stored charge of 45 μC .

For parts whose voltage, U , exceeds 15 kV peak or d.c., the circuit capacitance shall not exceed $700/U^2$ nF, where U is expressed in kilovolts.

NOTE 3 The limit of $700/U^2$ corresponds to an available energy of 350 mJ.

2.4.3 Connection of limited current circuits to other circuits

LIMITED CURRENT CIRCUITS are permitted to be supplied from or connected to other circuits, provided that the following conditions are met:

- the LIMITED CURRENT CIRCUIT meets the limits of 2.4.2 under normal operating conditions;
- the LIMITED CURRENT CIRCUIT continues to meet the limits of 2.4.2 in the event of a single failure of any component or insulation in the LIMITED CURRENT CIRCUIT, or of any component or insulation in the other circuit to which it is connected.

If a LIMITED CURRENT CIRCUIT is connected to one or more other circuits, the LIMITED CURRENT CIRCUIT is that part which complies with the requirements of 2.4.1.

2.5 Limited power sources

A limited power source shall comply with one of the following:

- the output is inherently limited in compliance with table 2B; or
- an impedance limits the output in compliance with table 2B. If a positive temperature coefficient device is used, it shall pass the tests specified in IEC 60730-1, clauses 15, 17, J15 and J17; or
- an overcurrent protective device is used and the output is limited in compliance with table 2C; or
- a regulating network limits the output in compliance with table 2B, both under normal operating conditions and after any single fault (see 1.4.14) in the regulating network (open circuit or short circuit); or
- a regulating network limits the output in compliance with table 2B under normal operating conditions, and an overcurrent protective device limits the output in compliance with table 2C after any single fault (see 1.4.14) in the regulating network (open circuit or short circuit).

Where an overcurrent protective device is used, it shall be a fuse or a non-adjustable, non-autoreset, electromechanical device.

A limited power source operated from an AC MAINS SUPPLY, or a battery-operated limited power source that is recharged from an AC MAINS SUPPLY while supplying the load, shall incorporate an isolating transformer.

Compliance is checked by inspection and measurement and, where appropriate, by examination of the manufacturer's data for batteries. Batteries shall be fully charged when conducting the measurements for U_{oc} and I_{sc} according to tables 2B and 2C.

The load referenced in items 2) and 3) of tables 2B and 2C is adjusted to develop maximum current and power transfer respectively. Single faults in a regulating network are applied under these maximum current and power conditions.

Table 2B – Limits for inherently limited power sources

Output voltage ¹⁾ (U_{oc})		Output current ²⁾ (I_{sc})	Apparent power ³⁾ (S)
V a.c.	V d.c.	A	VA
≤ 20	≤ 20	$\leq 8,0$	$\leq 5 \times U_{oc}$
$20 < U_{oc} \leq 30$	$20 < U_{oc} \leq 30$	$\leq 8,0$	≤ 100
–	$30 < U_{oc} \leq 60$	$\leq 150/U_{oc}$	≤ 100

1) U_{oc} : Output voltage measured in accordance with 1.4.5 with all load circuits disconnected. Voltages are for substantially sinusoidal a.c. and ripple free d.c. For non-sinusoidal a.c. and d.c. with ripple greater than 10 % of the peak, the peak voltage shall not exceed 42,4 V.

2) I_{sc} : Maximum output current with any non-capacitive load, including a short circuit, measured 60 s after application of the load.

3) S (VA): Maximum output VA with any non-capacitive load measured 60 s after application of the load.

**Table 2C – Limits for power sources not inherently limited
(overcurrent protective device required)**

Output voltage ¹⁾ (U_{oc})		Output current ²⁾ (I_{sc})	Apparent power ³⁾ (S)	Current rating of overcurrent protective device ⁴⁾
V a.c.	V d.c.	A	VA	A
≤ 20	≤ 20	$\leq 1\,000/U_{oc}$	≤ 250	$\leq 5,0$
$20 < U_{oc} \leq 30$	$20 < U_{oc} \leq 30$			$\leq 100/U_{oc}$
–	$30 < U_{oc} \leq 60$			$\leq 100/U_{oc}$

1) U_{oc} : Output voltage measured in accordance with 1.4.5 with all load circuits disconnected. Voltages are for substantially sinusoidal a.c. and ripple free d.c. For non-sinusoidal a.c. and for d.c. with ripple greater than 10 % of the peak, the peak voltage shall not exceed 42,4 V.

2) I_{sc} : Maximum output current with any non-capacitive load, including a short circuit, measured 60 s after application of the load. Current limiting impedances in the equipment remain in the circuit during measurement, but overcurrent protective devices are bypassed.

3) S (VA): Maximum output VA with any non-capacitive load measured 60 s after application of the load. Current limiting impedances in equipment remain in the circuit during measurement, but overcurrent protective devices are bypassed.

NOTE The reason for making measurements with overcurrent protective devices bypassed is to determine the amount of energy that is available to cause possible overheating during the operating time of the overcurrent protective devices.

4) The current ratings of overcurrent protective devices are based on fuses and circuit breakers that break the circuit within 120 s with a current equal to 210 % of the current rating specified in the table.

2.6 Provisions for earthing and bonding

NOTE For additional requirements with regard to earthing of equipment to be connected to TELECOMMUNICATION NETWORKS, see 2.3.2, 2.3.3, 6.1.1 and 6.1.2; and for CABLE DISTRIBUTION SYSTEMS, see 7.1 and 7.3.1.

2.6.1 Protective earthing

The following parts of equipment shall be reliably connected to the main protective earthing terminal of the equipment.

Parts likely to carry fault currents intended to operate overcurrent protective devices.

- a) Accessible conductive parts that might assume a HAZARDOUS VOLTAGE in the event of a single fault (see 1.4.14).
- b) Parts required to be earthed to maintain the integrity of SELV CIRCUITS, if required by 2.2.3.2 or 2.2.3.3.
- c) Parts required to be earthed to maintain the integrity of TNV CIRCUITS, if required by 2.3.3 b).
- d) SELV CIRCUITS, TNV CIRCUITS and accessible conductive parts required to be earthed by 2.3.2, if the power source is not a TELECOMMUNICATION NETWORK or a CABLE DISTRIBUTION SYSTEM.

Parts that carry other currents.

- e) SELV CIRCUITS, TNV CIRCUITS and accessible conductive parts required to be earthed by 2.3.2, if the power source is a TELECOMMUNICATION NETWORK or a CABLE DISTRIBUTION SYSTEM.
- f) Circuits, transformer screens and components (such as surge suppressors) that could not assume a HAZARDOUS VOLTAGE in the event of a single fault (see 1.4.14) but are required to be earthed in order to reduce transients that might affect insulation (for example see 6.2.1 and 7.3.1).
- g) SELV CIRCUITS and TNV CIRCUITS that are required to be earthed in order to reduce or eliminate TOUCH CURRENT to a TELECOMMUNICATION NETWORK or a CABLE DISTRIBUTION SYSTEM (see 5.1.8.1).

In SERVICE ACCESS AREAS, where conductive parts, such as motor frames, electronic chassis, etc., might assume a HAZARDOUS VOLTAGE in the event of a single fault (see 1.4.14), either these conductive parts shall be connected to the main protective earthing terminal or, if this is impossible or impracticable, a suitable marking shall indicate to a SERVICE PERSON that such parts are not earthed and should be checked for HAZARDOUS VOLTAGE before being touched.

Compliance is checked by inspection and, where appropriate, by the test specified in 2.6.3.

2.6.2 Functional earthing

If FUNCTIONAL EARTHING of accessible or other conductive parts is necessary, all of the following apply to the FUNCTIONAL EARTHING circuit:

- the FUNCTIONAL EARTHING circuit shall be separated from parts at HAZARDOUS VOLTAGES in the equipment by either:
 - DOUBLE INSULATION or REINFORCED INSULATION; or

- a protectively earthed screen or another protectively earthed conductive part, separated from parts at HAZARDOUS VOLTAGES by at least BASIC INSULATION; and
- it is permitted to connect the FUNCTIONAL EARTHING circuit to a protective earth terminal or to a PROTECTIVE BONDING CONDUCTOR; and
- wiring terminals to be used only for FUNCTIONAL EARTHING shall not be marked by the symbol \perp (60417-1-IEC-5017) or by the symbol \oplus (60417-1-IEC-5019), except that, where a wiring terminal is provided on a component (for example, a terminal block) or subassembly, the symbol \perp is permitted; and

NOTE Other markings such as one of the symbols, \oplus (60417-1-IEC-5018) or \perp (60417-1-IEC-5020), if appropriate, are permitted.

- for internal FUNCTIONAL EARTHING conductors, the colour combination green-and-yellow shall not be used except in multipurpose preassembled components (for example, multi-conductor cables or EMC filters); and
- in a power supply cord where a conductor having green-and-yellow insulation is used only to provide a FUNCTIONAL EARTHING connection;
 - the equipment shall not be marked with the symbol \square (60417-1-IEC-5172); and
 - there are no requirements other than those in 3.1.9 regarding the termination of this conductor at the equipment end.

Compliance is checked by inspection.

2.6.3 Protective earthing and protective bonding conductors

2.6.3.1 General

PROTECTIVE EARTHING CONDUCTORS and PROTECTIVE BONDING CONDUCTORS shall have sufficient current-carrying capacity.

The requirements of 2.6.3.2, 2.6.3.3 and 2.6.3.4 apply to PROTECTIVE EARTHING CONDUCTORS and PROTECTIVE BONDING CONDUCTORS provided to comply with 2.6.1 a), b), c) and d).

For PROTECTIVE EARTHING CONDUCTORS and PROTECTIVE BONDING CONDUCTORS provided to comply with 2.6.1 e), the requirements of 2.6.3.4 apply. The test current is 1,5 times the maximum current available from a TELECOMMUNICATION NETWORK or a CABLE DISTRIBUTION SYSTEM (if known) or 2 A, whichever is the greater.

For PROTECTIVE EARTHING CONDUCTORS and PROTECTIVE BONDING CONDUCTORS provided to comply with 2.6.1 f) and 2.6.1 g), and for FUNCTIONAL EARTHING conductors, the current-carrying capacity shall be adequate for the actual current under normal operating conditions, in accordance with 3.1.1, that is the conductors are not required to carry fault currents to earth.

2.6.3.2 Size of protective earthing conductors

PROTECTIVE EARTHING CONDUCTORS in power supply cords supplied with the equipment, shall comply with the minimum conductor sizes in table 3B (see 3.2.5).

Compliance is checked by inspection and measurement.

2.6.3.3 Size of protective bonding conductors

PROTECTIVE BONDING CONDUCTORS shall comply with one of the following:

- the minimum conductor sizes in table 3B (see 3.2.5); or
- the requirements of 2.6.3.4 and also, if the current rating of the circuit is more than 16 A, with the minimum conductor sizes in table 2D; or
- for components only, be not smaller than the conductors supplying power to the component.

The current rating of the circuit used in table 2D and in the test of 2.6.3.4 depends on the provision and location of overcurrent protective devices and shall be taken as the smaller of a) or b) as follows.

- a) The rating of an overcurrent protective device specified in the equipment installation instructions to be installed in the building installation wiring to protect the equipment.
- b) The rating of an overcurrent protective device in the equipment that protects the circuit or part required to be earthed.

For PLUGGABLE EQUIPMENT TYPE A, and if neither a) nor b) is applicable, the current rating of the circuit shall be taken as the RATED CURRENT of the equipment or 16 A, whichever is greater.

Compliance is checked by inspection and measurement.

Table 2D – Minimum size of protective bonding conductors

Current rating of the circuit under consideration A	Minimum conductor sizes	
	Cross-sectional area mm ²	AWG or kcmil (cross-sectional area in mm ²)
Up to and including 16	Size not specified	Size not specified
Over 16 up to and including 25	1,5	14 (2)
Over 25 up to and including 32	2,5	12 (3)
Over 32 up to and including 40	4,0	10 (5)
Over 40 up to and including 63	6,0	8 (8)
Over 63 up to and including 80	10	6 (13)
Over 80 up to and including 100	16	4 (21)
Over 100 up to and including 125	25	2 (33)
Over 125 up to and including 160	35	1 (42)
Over 160 up to and including 190	50	0 (53)
Over 190 up to and including 230	70	000 (85)
Over 230 up to and including 260	95	0000 (107)
Over 260 up to and including 300	120	250 kcmil (126)
Over 300 up to and including 340	150	300 kcmil (152)
Over 340 up to and including 400	185	400 kcmil (202)
Over 400 up to and including 460	240	500 kcmil (253)

NOTE AWG and kcmil sizes are provided for information only. The associated cross-sectional areas have been rounded to show significant figures only. AWG refers to the American Wire Gage and the term "cmil" refers to circular mils where one circular mil is equal to the area of a circle having a diameter of one mil (one thousandth of an inch). These terms are commonly used to designate wire sizes in North America.

2.6.3.4 Resistance of earthing conductors and their terminations

Earthing conductors and their terminations shall not have excessive resistance.

PROTECTIVE EARTHING CONDUCTORS are considered to comply without test.

PROTECTIVE BONDING CONDUCTORS that meet the minimum conductor sizes in table 3B (see 3.2.5) throughout their length and whose terminals all meet the minimum sizes in table 3E (see 3.3.5) are considered to comply without test.

Compliance is checked by inspection, measurement and, for PROTECTIVE BONDING CONDUCTORS that do not meet the minimum conductor sizes in table 3B (see 3.2.5) throughout their length or whose terminals do not all meet the minimum sizes in table 3E (see 3.3.5), by the following test.

The voltage drop in a PROTECTIVE BONDING CONDUCTOR is measured after conducting the test current for the time period specified below. The test current can be either a.c. or d.c. and the test voltage shall not exceed 12 V. The measurement is made between the main protective earthing terminal and the point in the equipment that is required by 2.6.1 to be earthed. The resistance of the PROTECTIVE EARTHING CONDUCTOR is not included in the measurement. However, if the PROTECTIVE EARTHING CONDUCTOR is supplied with the equipment, it is permitted to include the conductor in the test circuit but the measurement of the voltage drop is made only from the main protective earthing terminal to the part required to be earthed.

On equipment where the protective earth connection to a subassembly or to a separate unit is by means of one core of a multicore cable which also supplies mains power to that subassembly or unit, the resistance of the PROTECTIVE BONDING CONDUCTOR in that cable is not included in the measurement. However, this option is only permitted if the cable is protected by a suitably rated protective device which takes into account the size of the conductor.

If the protection of an SELV CIRCUIT is achieved by earthing in accordance with 2.2.3.3, the resistance limit applies from the earthed side of the SELV CIRCUIT to the main protective earthing terminal and not from the unearthed side of the SELV CIRCUIT.

Care is taken that the contact resistance between the tip of the measuring probe and the conductive part under test does not influence the test results.

The test current, duration of the test and test results are as follows:

- if the current rating of the circuit under test is 16 A or less, the test current is 1,5 times the current rating of the circuit under test, the current is applied for 60 s and the resistance of the PROTECTIVE BONDING CONDUCTOR, calculated from the voltage drop, shall not exceed 0,1 Ω ;*
- if the current rating of the circuit under test exceeds 16 A:*
 - for a.c. powered equipment, the test current is two times the current rating of the circuit under test, the current is applied for 2 min and the voltage drop across the PROTECTIVE BONDING CONDUCTOR shall not exceed 2,5 V;*
 - for d.c. powered equipment the test current and duration are as specified by the manufacturer and the voltage drop across the PROTECTIVE BONDING CONDUCTOR shall not exceed 2,5 V.*

2.6.3.5 Colour of insulation

The insulation of the PROTECTIVE EARTHING CONDUCTOR in a power supply cord supplied with the equipment shall be green-and-yellow.

If a PROTECTIVE BONDING CONDUCTOR is insulated, the insulation shall be green-and-yellow except in the following two cases:

- for an earthing braid, the insulation shall be either green-and-yellow or transparent;
- for a PROTECTIVE BONDING CONDUCTOR in assemblies such as ribbon cables, busbars, printed wiring, etc., any colour is permitted provided that no misinterpretation of the use of the conductor is likely to arise.

Except as permitted in 2.6.2, the colour combination green-and-yellow shall be used only to identify PROTECTIVE EARTHING CONDUCTORS and PROTECTIVE BONDING CONDUCTORS.

Compliance is checked by inspection.

2.6.4 Terminals

2.6.4.1 General

The requirements of 2.6.4.2 and 2.6.4.3 apply only to protective earthing terminals provided to comply with 2.6.1 a), b), c) and d).

NOTE For additional requirements concerning terminals, see 3.3.

For protective earthing provided to comply with 2.6.1 e), f) and g), it is sufficient for the terminals to comply with 3.3.

2.6.4.2 Protective earthing and bonding terminals

Equipment required to have protective earthing shall have a main protective earthing terminal. For equipment with a DETACHABLE POWER SUPPLY CORD, the earthing terminal in the appliance inlet is regarded as the main protective earthing terminal.

If equipment is provided with more than one supply connection (for example, with different voltages or frequencies or as backup power), it is permitted to have a main protective earthing terminal associated with each supply connection. In such a case, the terminals shall be sized according to the rating of the associated supply input.

Terminals shall be designed to resist accidental loosening of the conductor. In general, the designs commonly used for current-carrying terminals, other than some terminals of the pillar type, provide sufficient resilience to comply with this requirement; for other designs, special provisions, such as the use of an adequately resilient part which is not likely to be removed inadvertently, shall be used.

Except as noted below, all pillar, stud or screw type protective earthing and protective bonding terminals shall comply with the minimum size requirements of table 3E (see 3.3.5).

Where a terminal for a PROTECTIVE BONDING CONDUCTOR does not comply with table 3E (see 3.3.5), the test of 2.6.3.4 shall be applied to the PROTECTIVE BONDING CONDUCTOR path in which the terminal is used.

The main protective earthing terminal for PERMANENTLY CONNECTED EQUIPMENT shall be:

- located so that it is readily accessible while making the supply connections; and
- provided with factory installed pillar terminals, studs, screws, bolts or similar terminals, together with the necessary fixing hardware, if a PROTECTIVE EARTHING CONDUCTOR larger than 7 mm² (3 mm diameter) is required.

Compliance is checked by inspection and measurement.

2.6.4.3 Separation of the protective earthing conductor from protective bonding conductors

Separate wiring terminals, which may be on the same busbar, shall be provided, one for the PROTECTIVE EARTHING CONDUCTOR, or one for each PROTECTIVE EARTHING CONDUCTOR if more than one is provided, and one or more for PROTECTIVE BONDING CONDUCTORS.

However, it is permitted to provide a single wiring terminal of the screw or stud type in PERMANENTLY CONNECTED EQUIPMENT having a NON-DETACHABLE POWER SUPPLY CORD, and in PLUGGABLE EQUIPMENT TYPE A or B having a special NON-DETACHABLE POWER SUPPLY CORD, provided that the wiring termination of the PROTECTIVE EARTHING CONDUCTOR is separated by a nut from that of the PROTECTIVE BONDING CONDUCTORS. The order of stacking of the terminations of the PROTECTIVE EARTHING CONDUCTOR and the PROTECTIVE BONDING CONDUCTORS is not specified.

It is also permitted to provide a single wiring terminal in equipment with an appliance inlet.

Compliance is checked by inspection.

2.6.5 Integrity of protective earthing

2.6.5.1 Interconnection of equipment

In a system of interconnected equipment, the protective earthing connection shall be assured for all equipment requiring a protective earthing connection, regardless of the arrangement of equipment in the system.

Equipment that contains a PROTECTIVE BONDING CONDUCTOR to maintain continuity of protective earthing circuits to other equipment in the system, shall not be marked with the symbol  (60417-1-IEC-5172).

Such equipment shall also provide power to the other equipment in the system (see 2.6.5.3).

Compliance is checked by inspection.

2.6.5.2 Components in protective earthing conductors and protective bonding conductors

PROTECTIVE EARTHING CONDUCTORS and PROTECTIVE BONDING CONDUCTORS shall not contain switches or overcurrent protective devices.

Compliance is checked by inspection.

2.6.5.3 Disconnection of protective earth

Protective earthing connections shall be such that disconnection of a protective earth at one point in a unit or a system does not break the protective earthing connection to other parts or units in a system, unless the relevant hazard is removed at the same time.

Compliance is checked by inspection.

2.6.5.4 Parts that can be removed by an operator

Protective earthing connections shall make earlier and break later than the supply connections in each of the following:

- the connector of a part that can be removed by an OPERATOR;
- a plug on a power supply cord;
- an appliance coupler.

Compliance is checked by inspection.

2.6.5.5 Parts removed during servicing

Protective earthing connections shall be so designed that they do not have to be disconnected for servicing other than for the removal of the part which they protect unless the relevant hazard is removed at the same time.

Compliance is checked by inspection.

2.6.5.6 Corrosion resistance

Conductive parts in contact at protective earthing terminals and connections shall not be subject to significant corrosion due to electrochemical action in any working, storage or transport environment conditions as specified in the instructions supplied with the equipment. Combinations above the line in annex J shall be avoided. Corrosion resistance can be achieved by a suitable plating or coating process.

Compliance is checked by inspection and by reference to the table of electrochemical potentials (annex J).

2.6.5.7 Screws for protective bonding

NOTE The following requirements are additional to those in 3.1.6.

Self-tapping (thread-cutting and thread-forming) and spaced thread (sheet metal) screws are permitted to provide protective bonding but it shall not be necessary to disturb the connection during servicing.

In any case, the thickness of the metal part at the point where a screw is threaded into it shall be not less than twice the pitch of the screw thread. It is permitted to use local extrusion of a metal part to increase the effective thickness.

At least two screws shall be used for each connection. However, it is permitted to use a single self-tapping screw provided that the thickness of the metal part at the point where the screw is threaded into it is a minimum of 0,9 mm for a screw of the thread-forming type and 1,6 mm for a screw of the thread-cutting type.

Compliance is checked by inspection.

2.6.5.8 Reliance on telecommunication network or cable distribution system

Protective earthing shall not rely on a TELECOMMUNICATION NETWORK or a CABLE DISTRIBUTION SYSTEM.

Compliance is checked by inspection.

2.7 Overcurrent and earth fault protection in primary circuits

2.7.1 Basic requirements

Protection in PRIMARY CIRCUITS against overcurrents, short circuits and earth faults shall be provided, either as an integral part of the equipment or as part of the building installation.

If PLUGGABLE EQUIPMENT TYPE B or PERMANENTLY CONNECTED EQUIPMENT relies on protective devices in the building installation for protection, the equipment installation instructions shall so state and shall also specify the requirements for short-circuit protection or overcurrent protection or, where necessary, for both.

NOTE In the member countries of CENELEC, the protective devices necessary to comply with the requirements of 5.3 must, with certain exceptions, be included as part of the equipment.

2.7.2 Faults not covered in 5.3

Protection against faults not covered in 5.3 (for example, short circuits to protective earth from wiring in a PRIMARY CIRCUIT) need not be fitted as an integral part of the equipment.

Compliance is checked by inspection.

2.7.3 Short-circuit backup protection

Unless appropriate short-circuit backup protection is provided, protective devices shall have adequate breaking (rupturing) capacity to interrupt the maximum fault current (including short-circuit current) which can flow.

For PERMANENTLY CONNECTED EQUIPMENT or PLUGGABLE EQUIPMENT TYPE B, it is permitted for short circuit backup protection to be in the building installation.

For PLUGGABLE EQUIPMENT TYPE A, the building installation is considered as providing short-circuit backup protection.

NOTE If fuses complying with IEC 60127 are used in PRIMARY CIRCUITS, they should have high breaking capacity (1 500 A) if the prospective short-circuit current exceeds 35 A or 10 times the current rating of the fuse, whichever is greater.

Compliance is checked by inspection and by the tests of 5.3.

2.7.4 Number and location of protective devices

Protective systems or devices in PRIMARY CIRCUITS shall be in such a number and located so as to detect and to interrupt the overcurrent flowing in any possible fault current path (for example, line-to-line, line-to-neutral, line to protective earth conductor or line to PROTECTIVE BONDING CONDUCTOR).

No protection is required against earth faults in equipment that either:

- has no connection to earth; or
- has DOUBLE INSULATION or REINFORCED INSULATION between the PRIMARY CIRCUIT and all parts connected to earth.

NOTE 1 Where DOUBLE INSULATION or REINFORCED INSULATION is provided, a short circuit to earth would be considered to be two faults.

In a supply using more than one line conductor to a load, if a protective device interrupts the neutral conductor, it shall also interrupt all other supply conductors. Single pole protective devices, therefore, shall not be used in such cases.

Compliance is checked by inspection and, where necessary, by simulation of single fault conditions (see 1.4.14).

NOTE 2 For protective devices that are an integral part of the equipment, examples of the number and location of fuses or circuit-breaker poles necessary to provide fault current interruption in commonly encountered supply systems are given in informative table 2E for single-phase equipment or subassemblies and in informative table 2F for three-phase equipment. The examples are not necessarily valid for protective devices in the building installation.

Table 2E – Informative examples of protective devices in single-phase equipment or subassemblies

Equipment supply connections	Protection against	Minimum number of fuses or circuit-breaker poles	Location
Case A: Equipment to be connected to power distribution systems with earthed neutral reliably identified, except for case C below.	Earth faults	1	Line conductor
	Overcurrent	1	Either of the two conductors
Case B: Equipment to be connected to any supply, including IT power distribution systems and supplies with reversible plugs, except for case C below.	Earth faults	2	Both conductors
	Overcurrent	1	Either of the two conductors
Case C: Equipment to be connected to 3-wire power distribution systems with earthed neutral reliably identified.	Earth faults	2	Each line conductor
	Overcurrent	2	Each line conductor

**Table 2F – Informative examples of protective devices
in three-phase equipment**

Power distribution system	Number of supply conductors	Protection against	Minimum number of fuses or circuit-breaker poles	Location
Three-phase without neutral	3	Earth faults	3	All three conductors
		Overcurrent	2	Any two conductors
With earthed neutral (TN or TT)	4	Earth faults	3	Each line conductor
		Overcurrent	3	Each line conductor
With unearthed neutral	4	Earth faults	4	All four conductors
		Overcurrent	3	Each line conductor

2.7.5 Protection by several devices

Where protective devices are used in more than one pole of a supply to a given load, those devices shall be located together. It is permitted to combine two or more protective devices in one component.

Compliance is checked by inspection.

2.7.6 Warning to service persons

Suitable marking shall be provided on the equipment or a statement shall be provided in the servicing instructions to alert a SERVICE PERSON to a possible hazard, where both of the following conditions exist:

- where a fuse is used in the neutral of single-phase equipment either permanently connected or provided with a non-reversible plug; and
- where, after operation of the fuse, parts of the equipment that remain energized might represent a hazard during servicing.

The following or similar wording is regarded as suitable:

**CAUTION
DOUBLE POLE/NEUTRAL FUSING**

As an alternative to the above wording, use of the following combination of representative symbols, which includes the electric shock hazard symbol ISO 3864, No. 5036, the fuse symbol 60417-1-IEC-5016, and an indication that the fuse is in the neutral N, is permitted. However in this case, the statement shall also be provided in the servicing instructions.

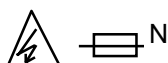

2.8 Safety interlocks

2.8.1 General principles

SAFETY INTERLOCKS shall be provided where OPERATOR access involves areas normally presenting hazards in the meaning of this standard.

Compliance is checked by inspection.

2.8.2 Protection requirements

SAFETY INTERLOCKS shall be so designed that the hazard will be removed before the covers, doors, etc., are in any position that will permit contact with hazardous parts by the test finger, figure 2A (see 2.1.1.1).

For protection against electric shock, radiation and energy hazards, removal, opening or withdrawal of the cover, door, etc., shall either:

- necessitate previous de-energization of such parts; or
- automatically initiate disconnection of the supply to such parts, and reduce within 2 s the voltage to 42,4 V peak, or 60 V d.c., or less, and the energy level to less than 20 J.

For a moving part which will continue to move through momentum and will continue to present a mechanical hazard (for example, a spinning print drum), removal, opening or withdrawal of the cover, door, etc., shall either:

- necessitate previous reduction of movement to an acceptable safe level; or
- automatically initiate reduction of the movement to an acceptable safe level.

Compliance is checked by inspection, measurement and use of the test finger, figure 2A (see 2.1.1.1).

2.8.3 Inadvertent reactivation

SAFETY INTERLOCKS shall be designed so that inadvertent reactivation of the hazard cannot occur when covers, guards, doors, etc., are not in the closed position.

Any accessible SAFETY INTERLOCK which can be operated by means of the test finger, figure 2A (see 2.1.1.1), is considered to be likely to cause inadvertent reactivation of the hazard.

SAFETY INTERLOCK switches shall be selected taking into account the mechanical shock and vibration experienced in normal operation, so that this does not cause inadvertent switching to an unsafe condition.

Compliance is checked by inspection and, where necessary, by a test with the test finger, figure 2A (see 2.1.1.1).

2.8.4 Fail-safe operation

A SAFETY INTERLOCK system shall be so designed and constructed that either:

- a failure of the SAFETY INTERLOCK system during the normal life of the equipment is not likely to occur and, even if a failure should occur, it shall not create an extreme hazard; or
- a failure of the SAFETY INTERLOCK system during the normal life of the equipment is possible, the probable failure mode(s) will not create a hazard for which protection is required.

Compliance is checked by inspection of the SAFETY INTERLOCK system, circuit diagrams and available data and, if necessary, by simulation of single faults (see 1.4.14) (for example, failure of a semi-conductor device or an electromechanical component). Moving mechanical parts in mechanical and electromechanical systems are not subjected to simulated single faults if they comply with 2.8.5 and 2.8.7.

It is permitted to use simulated SAFETY INTERLOCK systems for tests.

2.8.5 Moving parts

Moving mechanical parts in mechanical and electromechanical SAFETY INTERLOCK systems shall have adequate endurance.

Compliance is checked by inspection of the SAFETY INTERLOCK system, available data and, if necessary, by cycling the SAFETY INTERLOCK system through 10 000 operating cycles without failure other than in a safe mode.

NOTE The above test is carried out to check the endurance of moving parts other than those in SAFETY INTERLOCK switches and relays. SAFETY INTERLOCK switches and relays, if any, are subject to 2.8.7. If the test of 2.8.7.3 is required in addition to the above test, the tests should be combined.

2.8.6 Overriding

Where it may be necessary for a SERVICE PERSON to override a SAFETY INTERLOCK, the override system shall comply with all of the following:

- require an intentional effort to operate; and
- reset automatically to normal operation when servicing is complete, or prevent normal operation unless the SERVICE PERSON has carried out restoration; and
- require a TOOL for operation when in an OPERATOR ACCESS AREA and not be operable with the test finger, figure 2A (see 2.1.1.1); and
- not bypass a SAFETY INTERLOCK for an extreme hazard unless another reliable means of safety protection becomes effective when the SAFETY INTERLOCK is thus bypassed. The equipment shall be designed such that the SAFETY INTERLOCK cannot be bypassed until the other means of protection is fully in place and operational.

Compliance is checked by inspection.

2.8.7 Switches and relays

A switch in a SAFETY INTERLOCK system shall:

- for switches, conform to IEC 61058-1, with evaluation for 10 000 operating cycles in accordance with IEC 61058-1, 7.1.4.4; or
- comply with 2.8.7.1 and pass the tests of 2.8.7.3 and 2.8.7.4; or
- pass the tests of 2.8.7.2, 2.8.7.3 and 2.8.7.4.

A relay in a SAFETY INTERLOCK system shall:

- comply with 2.8.7.1 and pass the tests of 2.8.7.3 and 2.8.7.4; or
- pass the tests of 2.8.7.2, 2.8.7.3 and 2.8.7.4.

2.8.7.1 Contact gaps

If the contact gap is located in the PRIMARY CIRCUIT, the contact gap shall not be less than that for a disconnect device (see 3.4.2). If the contact gap is located in a circuit other than a PRIMARY CIRCUIT, the contact gap shall be not less than the relevant minimum CLEARANCE value for BASIC INSULATION in a SECONDARY CIRCUIT specified in 2.10.3.3.

Compliance is checked by inspection of the available data and, if necessary, by measurement.

2.8.7.2 Overload test

The contact of the SAFETY INTERLOCK switch or relay is subjected to an overload test consisting of 50 cycles of operation at the rate of 6 to 10 cycles per minute, making and breaking 150 % of the current imposed in the application, except that where a contact switches a motor load, the test is conducted with the rotor of the motor in a locked condition. After the test, the switch or relay shall still be functional.

2.8.7.3 Endurance test

The contact of the SAFETY INTERLOCK switch or relay is subjected to an endurance test, making and breaking 100 % of the current imposed in the application at a rate of 6 to 10 cycles of operation per minute. A higher rate of cycling is permitted if requested by the manufacturer. For reed switches in ELV CIRCUITS, SELV CIRCUITS and TNV-1 CIRCUITS, the test is 100 000 operating cycles. For other switches and relays, the test is 10 000 operating cycles. After the test, the switch or relay shall still be functional.

2.8.7.4 Electric strength test

Except for reed switches in ELV CIRCUITS, SELV CIRCUITS and TNV-1 CIRCUITS, an electric strength test as specified in 5.2.2, is applied between the contacts after the tests of 2.8.7.2 and 2.8.7.3. If the contact is in a PRIMARY CIRCUIT, the test voltage is as specified for REINFORCED INSULATION. If the contact is in a circuit other than a PRIMARY CIRCUIT, the test voltage is as specified for BASIC INSULATION in a PRIMARY CIRCUIT.

2.8.8 Mechanical actuators

Where the actuating part in a mechanical SAFETY INTERLOCK system is relied upon for safety, precautions shall be taken to ensure that it is not overstressed. If this requirement is not covered by the design of the component, the over-travel beyond the operating position of the actuator shall be limited to 50 % of the maximum (for example, by its mounting or location) or by adjustment.

Compliance is checked by inspection and measurement.

2.9 Electrical insulation

2.9.1 Properties of insulating materials

The choice and application of insulating materials shall take into account the needs for electrical, thermal and mechanical strength, frequency of the WORKING VOLTAGE and the working environment (temperature, pressure, humidity and pollution).

Natural rubber, hygroscopic materials and materials containing asbestos shall not be used as insulation.

Driving belts and couplings shall not be relied upon to ensure electrical insulation, unless the belt or coupling is of a special design which removes the risk of inappropriate replacement.

Compliance is checked by inspection and, where necessary, by evaluation of the data for the material.

Where necessary, if the data does not confirm that the material is non-hygroscopic, the hygroscopic nature of the material is determined by subjecting the component or subassembly employing the insulation in question to the humidity treatment of 2.9.2. The insulation is then subjected to the relevant electric strength test of 5.2.2 while still in the humidity cabinet, or in the room in which the samples were brought to the prescribed temperature.

2.9.2 Humidity conditioning

Where required by 2.9.1, 2.10.6.5 or 2.10.7, humidity conditioning is carried out for 48 h in a cabinet or room containing air with a relative humidity of 91 % to 95 %. The temperature of the air, at all places where samples can be located, is maintained within 1 °C of any convenient value t between 20 °C and 30 °C such that condensation does not occur. During this conditioning the component or subassembly is not energized.

With the concurrence of the manufacturer, it is permitted to increase the 48 h time duration.

Before the humidity conditioning the sample is brought to a temperature between t and $t + 4$ °C.

2.9.3 Grade of insulation

Insulation shall be considered to be FUNCTIONAL INSULATION, BASIC INSULATION, SUPPLEMENTARY INSULATION, REINFORCED INSULATION or DOUBLE INSULATION.

The application of insulation in many common situations is described in table 2G and illustrated in figure 2F, but other situations and solutions are possible. These examples are informative; in some cases the necessary grade of insulation may be higher or lower. Where a different grade may be necessary, or if a particular configuration of energized parts is not represented in the examples, the necessary grade of insulation should be determined by considering the effect of a single fault (see 1.4.14). This should leave the requirements for protection against electric shock intact.

In certain cases, insulation may be bridged by a conductive path (for example, where 1.5.7, 2.2.4, 2.3.4 or 2.4.3 applies) provided that the level of safety is maintained.

For DOUBLE INSULATION it is permitted to interchange the BASIC INSULATION and SUPPLEMENTARY INSULATION elements. Where DOUBLE INSULATION is used, ELV CIRCUITS or unearthed conductive parts are permitted between the BASIC INSULATION and the SUPPLEMENTARY INSULATION provided that the overall level of insulation is maintained.

Table 2G – Examples of application of insulation

Grade of insulation	Location of insulation		Key to figure 2F
	between	and	
FUNCTIONAL see 1)	unearthed SELV CIRCUIT or double-insulated conductive part	– earthed conductive part – double-insulated conductive part – unearthed SELV CIRCUIT – earthed SELV CIRCUIT – earthed TNV-1 CIRCUIT	F1 F2 F2 F1 F10 see 6)
	earthed SELV CIRCUIT	– earthed SELV CIRCUIT – earthed conductive part – unearthed TNV-1 CIRCUIT – earthed TNV-1 CIRCUIT	F11 F11 F12 see 6) F13 see 6)
	ELV CIRCUIT or basic- insulated conductive part	– earthed conductive part – earthed SELV CIRCUIT – basic-insulated conductive part – ELV CIRCUIT	F3 F3 F4 F4
	earthed HAZARDOUS VOLTAGE SECONDARY CIRCUIT	earthed HAZARDOUS VOLTAGE SECONDARY CIRCUIT	F5
	TNV-1 CIRCUIT	TNV-1 CIRCUIT	F7
	TNV-2 CIRCUIT	TNV-2 CIRCUIT	F8
	TNV-3 CIRCUIT	TNV-3 CIRCUIT	F9
	series-parallel sections of a transformer winding		F6
BASIC	PRIMARY CIRCUIT	– earthed or unearthed HAZARDOUS VOLTAGE SECONDARY CIRCUIT – earthed conductive part – earthed SELV CIRCUIT – basic-insulated conductive part – ELV CIRCUIT	B1 B2 B2 B3 B3
	earthed or unearthed HAZARDOUS VOLTAGE SECONDARY CIRCUIT	– unearthed HAZARDOUS VOLTAGE SECONDARY CIRCUIT – earthed conductive part – earthed SELV CIRCUIT – basic-insulated conductive part – ELV CIRCUIT	B4 B5 B5 B6 B6
	unearthed SELV CIRCUIT or double-insulated conductive part	– unearthed TNV-1 CIRCUIT – TNV-2 CIRCUIT – TNV-3 CIRCUIT	B7 see 6) B8 B9 see 5)
	earthed SELV CIRCUIT	– TNV-2 CIRCUIT – TNV-3 CIRCUIT	B10 see 4) B11 see 4) 5)
	TNV-2 CIRCUIT	– unearthed TNV-1 CIRCUIT – earthed TNV-1 CIRCUIT – TNV-3 CIRCUIT	B12 see 5) B13 see 4) 5) B14 see 6)
	TNV-3 CIRCUIT	– unearthed TNV-1 CIRCUIT – earthed TNV-1 CIRCUIT	B12 B13 see 4)
SUPPLEMENTARY	basic-insulated conductive part or ELV CIRCUIT	– double-insulated conductive part – unearthed SELV CIRCUIT	S1 see 2) S1 see 2)
	TNV CIRCUIT	– basic-insulated conductive part – ELV CIRCUIT	S2 see 4) S2

Table 2G (concluded)

Grade of insulation	Location of insulation		Key to figure 2F
	between	and	
SUPPLEMENTARY OR REINFORCED	unearthed HAZARDOUS VOLTAGE SECONDARY CIRCUIT	<ul style="list-style-type: none"> – double-insulated conductive part – unearthed SELV CIRCUIT – TNV CIRCUIT 	S/R1 see ³⁾ S/R1 see ³⁾ S/R2 see ³⁾
REINFORCED	PRIMARY CIRCUIT	<ul style="list-style-type: none"> – double-insulated conductive part – unearthed SELV CIRCUIT – TNV CIRCUIT 	R1 R1 R2
	earthed HAZARDOUS VOLTAGE SECONDARY CIRCUIT	<ul style="list-style-type: none"> – double-insulated conductive part – unearthed SELV CIRCUIT – TNV CIRCUIT 	R3 R3 R4
<p>1) See 5.3.4 for requirements for FUNCTIONAL INSULATION.</p> <p>2) The WORKING VOLTAGE of the SUPPLEMENTARY INSULATION between an ELV CIRCUIT or a basic-insulated conductive part and an unearthed accessible conductive part is equal to the most onerous WORKING VOLTAGE for the BASIC INSULATION. The most onerous WORKING VOLTAGE may be due to a PRIMARY CIRCUIT or SECONDARY CIRCUIT and the insulation is specified accordingly.</p> <p>3) Insulation between an unearthed SECONDARY CIRCUIT at HAZARDOUS VOLTAGE and an unearthed accessible conductive part or circuit (S/R in figure 2F) shall satisfy the more onerous of the following:</p> <ul style="list-style-type: none"> – REINFORCED INSULATION whose WORKING VOLTAGE is equal to the HAZARDOUS VOLTAGE; or – SUPPLEMENTARY INSULATION whose WORKING VOLTAGE is equal to the voltage between the SECONDARY CIRCUIT at HAZARDOUS VOLTAGE and <ul style="list-style-type: none"> • another SECONDARY CIRCUIT at HAZARDOUS VOLTAGE, or • a PRIMARY CIRCUIT. <p>These examples apply if:</p> <ul style="list-style-type: none"> – there is only BASIC INSULATION between the SECONDARY CIRCUIT and the PRIMARY CIRCUIT; and – there is only BASIC INSULATION between the SECONDARY CIRCUIT and earth. <p>4) BASIC INSULATION is not always required (see 2.3.2).</p> <p>5) The requirements of 2.10 apply. See also 6.2.1.</p> <p>6) The requirements of 2.10 do not apply, but see 6.2.1.</p>			
<p>NOTE The term "conductive part" refers to an electrically conductive part that is:</p> <ul style="list-style-type: none"> – not normally energized, and – not connected to any of the following: <ul style="list-style-type: none"> • a circuit at HAZARDOUS VOLTAGE, or • an ELV CIRCUIT, or • a TNV CIRCUIT, or • an SELV CIRCUIT, or • a LIMITED CURRENT CIRCUIT. <p>Examples of such a conductive part are the BODY of equipment, a transformer core, and in some cases a conductive screen in a transformer.</p> <p>If such a conductive part is protected from a part at HAZARDOUS VOLTAGE by:</p> <ul style="list-style-type: none"> – DOUBLE INSULATION or REINFORCED INSULATION, it is termed a "double-insulated conductive part"; – BASIC INSULATION plus protective earthing, it is termed an "earthed conductive part"; – BASIC INSULATION but is not earthed, that is it has no second level of protection, it is termed a "basic-insulated conductive part". <p>A circuit or conductive part is termed "earthed" if it is connected to a protective earthing terminal or contact in such a way as to meet the requirements in 2.6 (although it will not necessarily be at earth potential). Otherwise the circuit or conductive part is termed "unearthed".</p>			

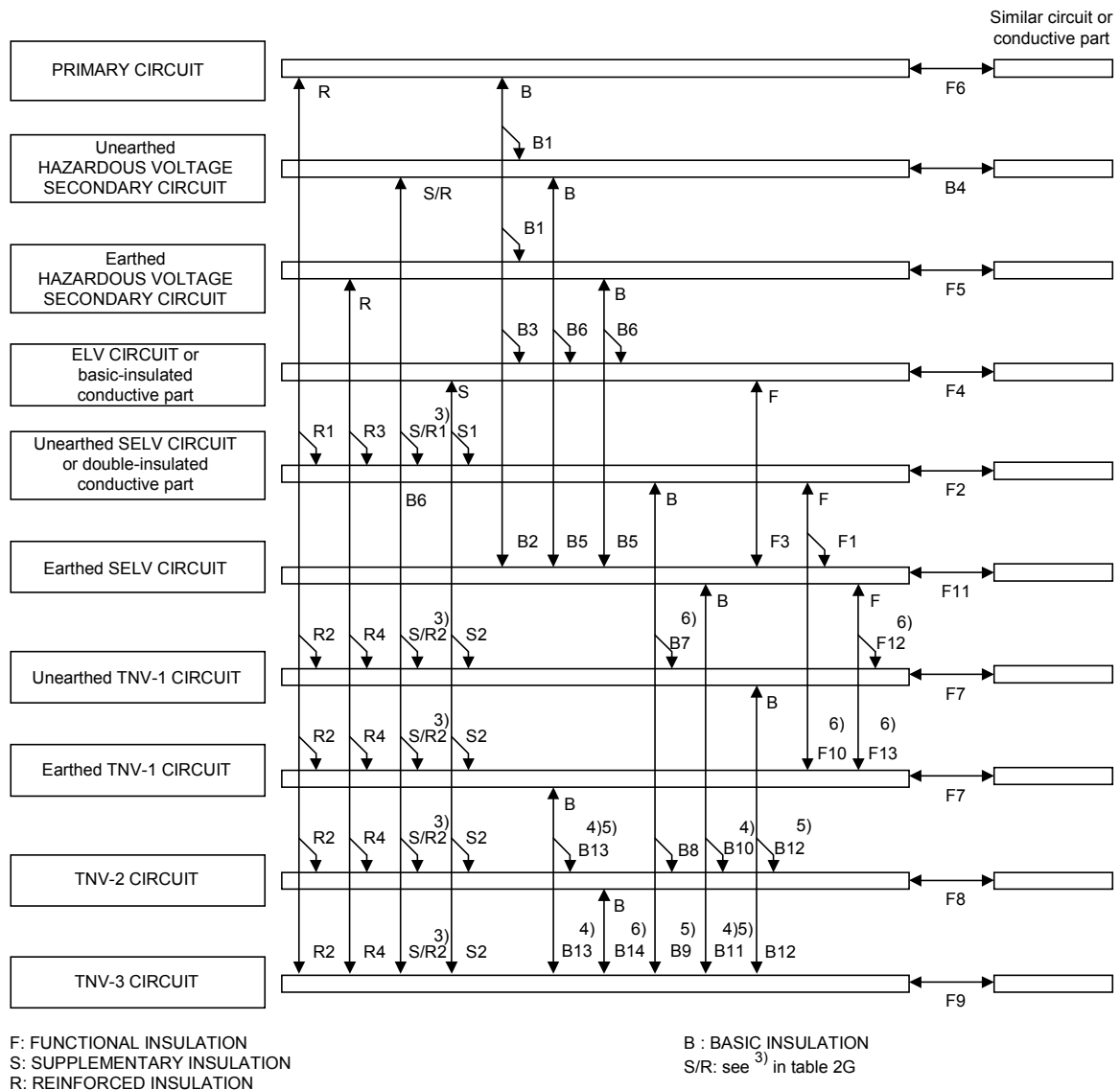

Figure 2F – Examples of application of insulation

2.10 Clearances, creepage distances and distances through insulation

2.10.1 General

CLEARANCES shall be so dimensioned that overvoltage transients which may enter the equipment, and peak voltages which may be generated within the equipment, do not break down the CLEARANCE. Detailed requirements are given in 2.10.3.

CREEPAGE DISTANCES shall be so dimensioned that, for a given WORKING VOLTAGE and Pollution Degree, no flashover or breakdown (tracking) of insulation will occur. Detailed requirements are given in 2.10.4.

When classifying a circuit in the equipment as an SELV CIRCUIT, TNV-1 CIRCUIT, TNV-2 CIRCUIT or a TNV-3 CIRCUIT for the purposes of determining CLEARANCES and electric strength requirements, the normal operating voltages and any overvoltages coming from the AC MAINS SUPPLY or DC MAINS SUPPLY shall be taken into account.

The methods of measuring CLEARANCES and CREEPAGE DISTANCES are given in annex F.

Solid insulation shall be:

- so dimensioned that overvoltage transients that enter the equipment and peak voltages that may be generated within the equipment, do not break down the solid insulation; and
- for thin layers of insulation, so arranged that the likelihood of having pinholes aligned is limited.

Detailed requirements are given in 2.10.5.

The insulation requirements given in 2.10 are for frequencies up to 30 kHz. It is permitted to use the same requirements for insulation operating at frequencies over 30 kHz until additional data is available.

NOTE For information on insulation behaviour in relation to frequency see IEC 60664-1 and IEC 60664-4.

For FUNCTIONAL INSULATION, CLEARANCES and CREEPAGE DISTANCES smaller than those specified in 2.10 are permitted subject to the requirements of 5.3.4 b) or 5.3.4 c).

It is permitted for CLEARANCES and CREEPAGE DISTANCES to be divided by intervening, unconnected (floating) conductive parts, such as unused contacts of a connector, provided that the sum of the individual distances meets the specified minimum requirements (see figure F.13).

The minimum CLEARANCE and CREEPAGE DISTANCE values given for various Pollution Degrees apply as follows:

- Pollution Degree 1 for components and assemblies which are sealed so as to exclude dust and moisture (see 2.10.7).
- Pollution Degree 2 generally for equipment covered by the scope of this standard.
- Pollution Degree 3 where a local internal environment within the equipment is subject to conductive pollution or to dry non-conductive pollution which could become conductive due to expected condensation.

2.10.2 Determination of working voltage

In determining the WORKING VOLTAGES, all of the following requirements apply (see also 1.4.7):

- the value of the RATED VOLTAGE or the upper voltage of the RATED VOLTAGE RANGE shall be:
 - used for WORKING VOLTAGE between a PRIMARY CIRCUIT and earth; and
 - taken into account for determination of the WORKING VOLTAGE between a PRIMARY CIRCUIT and a SECONDARY CIRCUIT; and

- unearthed accessible conductive parts shall be assumed to be earthed; and
- where a transformer winding or other part is floating, that is not connected to a circuit which establishes its potential relative to earth, it shall be assumed to be earthed at the point by which the highest WORKING VOLTAGE is obtained; and
- where DOUBLE INSULATION is used, the WORKING VOLTAGE across the BASIC INSULATION shall be determined by imagining a short circuit across the SUPPLEMENTARY INSULATION, and vice versa. For DOUBLE INSULATION between transformer windings, the short circuit shall be assumed to take place at the point by which the highest WORKING VOLTAGE is produced in the other insulation; and
- except as permitted in 2.10.10, for insulation between two transformer windings, the highest voltage between any two points in the two windings shall be used, taking into account external voltages to which the windings will be connected; and
- except as permitted in 2.10.10, for insulation between a transformer winding and another part, the highest voltage between any point on the winding and the other part shall be used.

2.10.3 Clearances

2.10.3.1 General

It is permitted to use either the following method or the alternative method in annex G for a particular component or subassembly or for the whole equipment.

NOTE 1 The advantages of annex G are as follows.

- CLEARANCES are aligned with the basic safety publication IEC 60664-1 and are therefore harmonized with other safety publications (for example, transformers).
- Additional flexibility is provided for the designer due to an improved interpolation method compared to the method in 2.10.3 where steps are taken from one line to the next in tables 2H, 2J and 2K.
- Attenuation of transients within the equipment is considered, including attenuation of transients in PRIMARY CIRCUITS.
- Inconsistencies in table 2H are corrected (4 000 V_{peak} requires 2,0 mm or 2,5 mm for FUNCTIONAL INSULATION and 3,2 mm for BASIC INSULATION).

NOTE 2 For equipment intended to be supplied from the AC MAINS SUPPLY, CLEARANCE and electric strength requirements are based on the expected overvoltage transients which may enter the equipment from the AC MAINS SUPPLY. According to IEC 60664-1, the magnitude of these transients is determined by the normal supply voltage and the supply arrangements. These transients are categorized according to IEC 60664-1 into four groups as Overvoltage Categories I to IV (also known as installation categories I to IV). Annex G covers all four Overvoltage Categories. Elsewhere in this standard Overvoltage Category II is assumed.

NOTE 3 The design of solid insulation and CLEARANCES should be coordinated in such a way that if an incident overvoltage transient exceeds the limits of Overvoltage Category II, the solid insulation can withstand a higher voltage than the CLEARANCES.

For all a.c. power distribution systems, the AC MAINS SUPPLY voltage in tables 2H, 2J and 2K is the line-to-neutral voltage.

NOTE 4 In Norway, due to the IT power distribution system used (see annex V, figure V.7), the AC MAINS SUPPLY voltage is considered to be equal to the line-to-line voltage, and will remain 230 V in case of a single earth fault.

For circuitry intended to be connected to a DC MAINS SUPPLY, the requirements for an SELV CIRCUIT, TNV CIRCUIT or HAZARDOUS VOLTAGE SECONDARY CIRCUIT apply depending on its maximum normal operating voltage and any overvoltages expected.

The specified CLEARANCES are subject to the following minimum values:

- 10 mm for an air gap serving as REINFORCED INSULATION between a part at HAZARDOUS VOLTAGE and an accessible conductive part of the ENCLOSURE of floor-standing equipment or of the non-vertical top surface of desk top equipment;
- 2 mm for an air gap serving as BASIC INSULATION between a part at HAZARDOUS VOLTAGE and an earthed accessible conductive part of the external ENCLOSURE of PLUGGABLE EQUIPMENT TYPE A.

The specified CLEARANCES are not applicable to the air gap between the contacts of THERMOSTATS, THERMAL CUT-OUTS, overload protection devices, switches of microgap construction, and similar components where the CLEARANCE varies with the contacts.

NOTE 5 For air gaps between contacts of interlock switches, see 2.8.7.1. For air gaps between contacts of disconnect switches, see 3.4.2.

Compliance with 2.10.3 is checked by measurement, taking into account annex F. There is no electric strength test to verify CLEARANCES. The following conditions are applicable:

- *movable parts shall be placed in the most unfavourable position;*
- *the force tests of 4.2.2, 4.2.3 and 4.2.4 apply;*
- *when measuring CLEARANCES from an ENCLOSURE of insulating material through a slot or opening in the ENCLOSURE, the accessible surface shall be considered to be conductive as if it were covered by metal foil wherever it can be touched by the test finger, figure 2A (see 2.1.1.1), applied without appreciable force (see figure F.12, point B).*

2.10.3.2 Clearances in primary circuits

CLEARANCES in PRIMARY CIRCUITS shall comply with the minimum dimensions in table 2H and, where appropriate, table 2J.

Table 2H is applicable to equipment that will not be subjected to transients exceeding Overvoltage Category II according to IEC 60664-1. The appropriate MAINS TRANSIENT VOLTAGES are given in each column. If higher transients are expected, additional protection might be necessary in the AC MAINS SUPPLY to the equipment or in the installation.

NOTE 1 Annex G provides an alternative design method for higher transients.

For PRIMARY CIRCUITS operating on nominal AC MAINS SUPPLY voltages up to 300 V, if the PEAK WORKING VOLTAGE in the circuit exceeds the peak value of the AC MAINS SUPPLY voltage, the minimum CLEARANCE for the insulation under consideration is the sum of the following two values:

- the minimum CLEARANCE value from table 2H for a WORKING VOLTAGE equal to the AC MAINS SUPPLY voltage; and
- the appropriate additional CLEARANCE value from table 2J.

For a WORKING VOLTAGE to be used in determining CLEARANCES for PRIMARY CIRCUITS in accordance with table 2H:

- the peak value of any superimposed ripple on a DC VOLTAGE, shall be included;
- non-repetitive transients (for example, due to atmospheric disturbances) shall not be taken into account;

NOTE 2 It is assumed that any such non-repetitive transients in a SECONDARY CIRCUIT will not exceed the MAINS TRANSIENT VOLTAGE of the PRIMARY CIRCUIT.

- the voltage of any ELV CIRCUIT, SELV CIRCUIT or TNV CIRCUIT (including ringing voltage) shall be regarded as zero;

and in accordance with table 2J, where appropriate, for PEAK WORKING VOLTAGES exceeding the values of the AC MAINS SUPPLY voltage, the maximum PEAK WORKING VOLTAGE shall be used.

NOTE 3 The total CLEARANCES obtained by the use of table 2J lie between the values required for homogeneous and inhomogeneous fields. As a result, they may not assure conformance with the appropriate electric strength test in case of fields which are substantially inhomogeneous.

NOTE 4 Use of CLEARANCE – tables 2H and 2J:

Select the appropriate column in table 2H for the MAINS TRANSIENT VOLTAGE and Pollution Degree. Select the row appropriate to a WORKING VOLTAGE equal to the AC MAINS SUPPLY voltage. Note the minimum CLEARANCE requirement.

Go to table 2J. Select the appropriate column for the nominal AC MAINS SUPPLY voltage and Pollution Degree and choose the row in that column which covers the actual PEAK WORKING VOLTAGE. Read the additional CLEARANCE required from one of the two right hand columns and add this to the minimum CLEARANCE from table 2H to give the total minimum CLEARANCE.

**Table 2H – Minimum clearances for insulation in primary circuits
and between primary and secondary circuits**

CLEARANCES in millimetres

WORKING VOLTAGE up to and including		MAINS TRANSIENT VOLTAGE 1 500 V (Nominal AC MAINS SUPPLY voltage ≤150 V)						MAINS TRANSIENT VOLTAGE 2 500 V (Nominal AC MAINS SUPPLY voltage >150 V ≤ 300 V)						MAINS TRANSIENT VOLTAGE 4 000 V (Nominal AC MAINS SUPPLY voltage >300 V ≤ 600 V)			
Voltage peak or d.c.	Voltage r.m.s. (sinu- soidal)	Pollution Degrees 1 and 2			Pollution Degree 3			Pollution Degrees 1 and 2			Pollution Degree 3			Pollution Degrees 1, 2 and 3			
		F	B/S	R	F	B/S	R	F	B/S	R	F	B/S	R	F	B/S	R	
V	V																
71	50	0,4	1,0 (0,5)	2,0 (1,0)	0,8	1,3 (0,8)	2,6 (1,6)	1,0	2,0 (1,5)	4,0 (3,0)	1,3	2,0 (1,5)	4,0 (3,0)	2,0	3,2 (3,0)	6,4 (6,0)	
210	150	0,5	1,0 (0,5)	2,0 (1,0)	0,8	1,3 (0,8)	2,6 (1,6)	1,4	2,0 (1,5)	4,0 (3,0)	1,5	2,0 (1,5)	4,0 (3,0)	2,0	3,2 (3,0)	6,4 (6,0)	
420	300	F 1,5 B/S 2,0 (1,5) R 4,0 (3,0)											2,5	3,2 (3,0)	6,4 (6,0)		
840	600	F 3,0 B/S 3,2 (3,0) R 6,4 (6,0)															
1 400	1 000	F/B/S 4,2 R 6,4															
2 800	2 000	F/B/S/R 8,4															
7 000	5 000	F/B/S/R 17, 5															
9 800	7 000	F/B/S/R 25															
14 000	10 000	F/B/S/R 37															
28 000	20 000	F/B/S/R 80															
42 000	30 000	F/B/S/R 130															
<p>1) The values in the table are applicable to FUNCTIONAL INSULATION (F), BASIC INSULATION (B), SUPPLEMENTARY INSULATION (S) and REINFORCED INSULATION (R).</p> <p>2) The values in parentheses are applicable to BASIC INSULATION, SUPPLEMENTARY INSULATION or REINFORCED INSULATION only if manufacturing is subjected to a quality control programme that provides at least the same level of assurance as the example given in clause R.2. In particular, DOUBLE INSULATION and REINFORCED INSULATION shall be subjected to ROUTINE TESTS for electric strength.</p> <p>3) For WORKING VOLTAGES between 2 800 V peak or d.c. and 42 000 V peak or d.c., linear interpolation is permitted between the nearest two points, the calculated spacing being rounded up to the next higher 0,1 mm increment.</p>																	

Table 2J – Additional clearances for insulation in primary circuits with peak working voltages exceeding the peak value of the nominal a.c. mains supply voltage

Nominal AC MAINS SUPPLY voltage ≤150 V		Nominal AC MAINS SUPPLY voltage >150 V ≤ 300 V	Additional CLEARANCE mm	
Pollution Degrees 1 and 2	Pollution Degree 3	Pollution Degrees 1, 2 and 3	FUNCTIONAL, BASIC OR SUPPLEMENTARY INSULATION	REINFORCED INSULATION
Maximum PEAK WORKING VOLTAGE V	Maximum PEAK WORKING VOLTAGE V	Maximum PEAK WORKING VOLTAGE V		
210 (210)	210 (210)	420 (420)	0	0
298 (288)	294 (293)	493 (497)	0,1	0,2
386 (366)	379 (376)	567 (575)	0,2	0,4
474 (444)	463 (459)	640 (652)	0,3	0,6
562 (522)	547 (541)	713 (729)	0,4	0,8
650 (600)	632 (624)	787 (807)	0,5	1,0
738 (678)	715 (707)	860 (884)	0,6	1,2
826 (756)	800 (790)	933 (961)	0,7	1,4
914 (839)		1 006 (1 039)	0,8	1,6
1 002 (912)		1 080 (1 116)	0,9	1,8
1 090 (990)		1 153 (1 193)	1,0	2,0
		1 226 (1 271)	1,1	2,2
		1 300 (1 348)	1,2	2,4
		– (1 425)	1,3	2,6

The values in parentheses shall apply:

- when the values in parentheses in table 2H are used in accordance with item 2) of table 2H; and
- for FUNCTIONAL INSULATION.

2.10.3.3 Clearances in secondary circuits

CLEARANCES in SECONDARY CIRCUITS shall comply with the minimum dimensions of table 2K.

For a WORKING VOLTAGE to be used in determining CLEARANCES for SECONDARY CIRCUITS in accordance with table 2K:

- the peak value of any superimposed ripple on a DC VOLTAGE, shall be included;
- the peak value shall be used for non-sinusoidal voltages.

A SECONDARY CIRCUIT derived from an AC MAINS SUPPLY will normally be Overvoltage Category I if the PRIMARY CIRCUIT is Overvoltage Category II; the maximum transients for various AC MAINS SUPPLY voltages in Overvoltage Category I are shown in the column headings of table 2K. However, a floating SECONDARY CIRCUIT shall be subjected to the requirements for PRIMARY CIRCUIT in tables 2H and 2J unless it is in equipment with a protective earthing terminal and either:

- it is separated from the PRIMARY CIRCUIT by an earthed metal screen; or
- transients on the SECONDARY CIRCUIT are below the permitted maximum value for Overvoltage Category I (for example, due to being attenuated by connecting a component, such as a capacitor, between the SECONDARY CIRCUIT and earth). See 2.10.3.4 for the method of measuring the transient level.

For the purposes of using table 2K for equipment to be supplied from a DC MAINS SUPPLY that is connected to protective earth and is entirely within a single building, the MAINS TRANSIENT VOLTAGE is considered to be zero.

NOTE 1 The connection to protective earth can be at the source of the DC MAINS SUPPLY or at the equipment location, or both (see ITU-T Recommendation K.27).

For equipment to be supplied from a DC MAINS SUPPLY that is not connected to protective earth, the value of the MAINS TRANSIENT VOLTAGE in the DC MAINS SUPPLY is the same as the MAINS TRANSIENT VOLTAGE in the PRIMARY CIRCUIT from which it is derived.

NOTE 2 For CLEARANCES which are provided for compliance with 2.3.2, table 2K applies.

If the TELECOMMUNICATION NETWORK TRANSIENT VOLTAGE is not known, an assumed transient rating of 800 V peak should be used for TNV-2 CIRCUITS and 1,5 kV peak for TNV-1 CIRCUITS and TNV-3 CIRCUITS.

If the TELECOMMUNICATION NETWORK TRANSIENT VOLTAGE is known, the known value should be used.

If it is known that the incoming transients will be attenuated within the equipment, the value should be determined in accordance with 2.10.3.4 b) and be used.

The effect of transients from a CABLE DISTRIBUTION SYSTEM is not taken into account when determining CLEARANCES (however, see 7.3.1).

Table 2K – Minimum clearances in secondary circuits

CLEARANCES in millimetres

WORKING VOLTAGE up to and including		Transient rating for SECONDARY CIRCUIT 800 V see 5) (Nominal AC MAINS SUPPLY voltage ≤150 V)						Transient rating for SECONDARY CIRCUIT 1 500 V see 5) (Nominal AC MAINS SUPPLY voltage >150 V ≤ 300 V)						Transient rating for SECONDARY CIRCUIT 2 500 V see 5) (Nominal AC MAINS SUPPLY voltage >300 V ≤ 600 V)			Circuit not subject to transient overvoltages see 4)		
Voltage peak or d.c. V	Voltage r.m.s. (sinu- soidal) V	Pollution Degrees 1 and 2			Pollution Degree 3			Pollution Degrees 1 and 2			Pollution Degree 3			Pollution Degrees 1, 2 and 3			Pollution Degrees 1 and 2 only		
		F	B/S	R	F	B/S	R	F	B/S	R	F	B/S	R	F	B/S	R	F	B/S	R
71	50	0,4 (0,2)	0,7 (0,2)	1,4 (0,4)	1,0 (0,8)	1,3 (0,8)	2,6 (1,6)	0,7 (0,5)	1,0 (0,5)	2,0 (1,0)	1,0 (0,8)	1,3 (0,8)	2,6 (1,6)	1,7 (1,5)	2,0 (1,5)	4,0 (3,0)	0,4 (0,2)	0,4 (0,2)	0,8 (0,4)
140	100	0,6 (0,2)	0,7 (0,2)	1,4 (0,4)	1,0 (0,8)	1,3 (0,8)	2,6 (1,6)	0,7 (0,5)	1,0 (0,5)	2,0 (1,0)	1,0 (0,8)	1,3 (0,8)	2,6 (1,6)	1,7 (1,5)	2,0 (1,5)	4,0 (3,0)	0,6 (0,2)	0,7 (0,2)	1,4 (0,4)
210	150	0,6 (0,2)	0,9 (0,2)	1,8 (0,4)	1,0 (0,8)	1,3 (0,8)	2,6 (1,6)	0,7 (0,5)	1,0 (0,5)	2,0 (1,0)	1,0 (0,8)	1,3 (0,8)	2,6 (1,6)	1,7 (1,5)	2,0 (1,5)	4,0 (3,0)	0,6 (0,2)	0,7 (0,2)	1,4 (0,4)
280	200	F 1,1 (0,8) B/S 1,4 (0,8) R 2,8 (1,6)												1,7 (1,5)	2,0 (1,5)	4,0 (3,0)	1,1 (0,2)	1,1 (0,2)	2,2 (0,4)
420	300	F 1,6 (1,0) B/S 1,9 (1,0) R 3,8 (2,0)												1,7 (1,5)	2,0 (1,5)	4,0 (3,0)	1,4 (0,2)	1,4 (0,2)	2,8 (0,4)
700	500													F/B/S 2,5			R 5,0		
840	600													F/B/S 3,2			R 5,0		
1 400	1 000													F/B/S 4,2			R 5,0		
2 800	2 000													F/B/S/R 8,4			See 6)		
7 000	5 000													F/B/S/R 17,5			See 6)		
9 800	7 000													F/B/S/R 25			See 6)		
14 000	10 000													F/B/S/R 37			See 6)		
28 000	20 000													F/B/S/R 80			See 6)		
42 000	30 000													F/B/S/R 130			See 6)		

- 1) The values in the table are applicable to FUNCTIONAL INSULATION (F), BASIC INSULATION (B), SUPPLEMENTARY INSULATION (S) and REINFORCED INSULATION (R).
- 2) The values in parentheses are applicable to BASIC INSULATION, SUPPLEMENTARY INSULATION or REINFORCED INSULATION only if manufacturing is subjected to a quality control programme that provides at least the same level of assurance as the example given in clause R.2. In particular, DOUBLE INSULATION and REINFORCED INSULATION shall be subjected to ROUTINE TESTS for electric strength.
- 3) For WORKING VOLTAGES between 2 800 V peak or d.c. and 42 000 V peak or d.c., linear interpolation is permitted between the nearest two points, the calculated spacing being rounded up to the next higher 0,1 mm increment.
- 4) The values are applicable to d.c. SECONDARY CIRCUITS which are reliably connected to earth and have capacitive filtering which limits the peak-to-peak ripple to 10 % of the DC VOLTAGE.
- 5) Where transients in the equipment exceed this value, the appropriate higher CLEARANCE shall be used.
- 6) For WORKING VOLTAGES above 1 400 V peak or d.c. or 1 000 V r.m.s. the minimum CLEARANCE is 5 mm provided that the CLEARANCE path is:
 - entirely through air, or
 - wholly or partly along the surface of an insulating material of Material Group I;
 - and the insulation involved passes an electric strength test according to 5.2.2 using:
 - an a.c. test voltage whose r.m.s. value is equal to 1,06 times the PEAK WORKING VOLTAGE, or
 - a d.c. test voltage equal to the peak value of the a.c. test voltage prescribed above.

If the CLEARANCE path is partly along the surface of a material that is not Material Group I, the electric strength test is conducted across the air gap only.

2.10.3.4 Measurement of transient voltage levels

The following tests are conducted only where it is required to determine whether or not transient voltage across the CLEARANCE in any circuit is lower than normal (for example, due to the effect of a filter in the equipment). The transient voltage across the CLEARANCE is measured using the following test procedure, and the CLEARANCE shall be based on the measured value.

During the tests, the equipment is connected to its separate power supply unit, if any, but is not connected to the mains, nor to any TELECOMMUNICATION NETWORKS, and any surge suppressors in PRIMARY CIRCUITS are disconnected.

A voltage measuring device is connected across the CLEARANCE in question.

a) Transients due to MAINS TRANSIENT VOLTAGES on the AC MAINS SUPPLY

To measure the reduced level of transient voltages across a CLEARANCE due to MAINS TRANSIENT VOLTAGES on the AC MAINS SUPPLY, the impulse test generator reference 2 of table N.1 is used to generate 1,2/50 μ s impulses. U_c is equal to the MAINS TRANSIENT VOLTAGE given in the column headings of table 2H.

NOTE For a DC MAINS SUPPLY, see G.2.2 and clause G.5.

Three to six impulses of alternating polarity, with intervals of at least 1 s between impulses, are applied between each of the following points where relevant:

- line-to-line;
- all line conductors joined together and neutral;
- all line conductors joined together and protective earth;
- neutral and protective earth.

b) Transients due to TELECOMMUNICATION NETWORK TRANSIENT VOLTAGES

To measure the reduced level of transient voltages across a CLEARANCE due to TELECOMMUNICATION NETWORK TRANSIENT VOLTAGES, the impulse test generator reference 1 of table N.1 is used to generate 10/700 μ s impulses. U_c is equal to the TELECOMMUNICATION NETWORK TRANSIENT VOLTAGE.

If the TELECOMMUNICATION NETWORK TRANSIENT VOLTAGE is not known for the TELECOMMUNICATION NETWORK in question, it shall be taken as:

- 1 500 V_{peak} if the circuit connected to the TELECOMMUNICATION NETWORK is a TNV-1 CIRCUIT or a TNV-3 CIRCUIT; and
- 800 V_{peak} if the circuit connected to the TELECOMMUNICATION NETWORK is an SELV CIRCUIT or a TNV-2 CIRCUIT.

Three to six impulses of alternating polarity, with intervals of at least 1 s between impulses, are applied between each of the following TELECOMMUNICATION NETWORK connection points:

- each pair of terminals (for example, A and B or tip and ring) in an interface;
- all terminals of a single interface type joined together and earth.

2.10.4 Creepage distances

CREEPAGE DISTANCES shall be not less than the appropriate minimum values specified in table 2L, taking into account the value of the WORKING VOLTAGE, the Pollution Degree and the Material Group.

For REINFORCED INSULATION, the values for CREEPAGE DISTANCE are twice the values for BASIC INSULATION in table 2L.

If the minimum CREEPAGE DISTANCE derived from table 2L is less than the applicable minimum CLEARANCE, that value of minimum CLEARANCE shall be applied as the minimum CREEPAGE DISTANCE.

It is permitted to use minimum CREEPAGE DISTANCES equal to the applicable CLEARANCES for glass, mica, ceramic or similar materials.

For the WORKING VOLTAGE to be used in determining CREEPAGE DISTANCES:

- the actual r.m.s. or d.c. value shall be used;
- if the d.c. value is used, any superimposed ripple shall not be taken into account;
- short-term conditions (for example, cadenced ringing signals in TNV CIRCUITS) shall not be taken into account;
- short-term disturbances (for example, transients) shall not be taken into account.

When determining the WORKING VOLTAGE for a TNV CIRCUIT connected to a TELECOMMUNICATION NETWORK whose characteristics are not known, the normal operating voltages shall be assumed to be the following values:

- 60 V d.c. for TNV-1 CIRCUITS;
- 120 V d.c. for TNV-2 CIRCUITS and TNV-3 CIRCUITS.

Material Groups are classified as follows:

Material Group I	$600 \leq \text{CTI}$ (comparative tracking index)
Material Group II	$400 \leq \text{CTI} < 600$
Material Group IIIa	$175 \leq \text{CTI} < 400$
Material Group IIIb	$100 \leq \text{CTI} < 175$

The Material Group is verified by evaluation of the test data for the material according to IEC 60112 using 50 drops of solution A.

If the Material Group is not known, Material Group IIIb shall be assumed.

If a CTI of 175 or greater is needed, and the data is not available, the Material Group can be established with a test for proof tracking index (PTI) as detailed in IEC 60112. A material may be included in a group if its PTI established by these tests is equal to, or greater than, the lower value of the CTI specified for the group.

Table 2L – Minimum creepage distances

CREEPAGE DISTANCES in millimetres

WORKING VOLTAGE V r.m.s. or d.c.	FUNCTIONAL, BASIC and SUPPLEMENTARY INSULATION						
	Pollution Degree 1	Pollution Degree 2			Pollution Degree 3		
	Material Group	Material Group			Material Group		
	I, II, IIIa or IIIb	I	II	IIIa or IIIb	I	II	IIIa or IIIb
≤50	see 1)	0,6	0,9	1,2	1,5	1,7	1,9
100		0,7	1,0	1,4	1,8	2,0	2,2
125		0,8	1,1	1,5	1,9	2,1	2,4
150		0,8	1,1	1,6	2,0	2,2	2,5
200		1,0	1,4	2,0	2,5	2,8	3,2
250		1,3	1,8	2,5	3,2	3,6	4,0
300		1,6	2,2	3,2	4,0	4,5	5,0
400		2,0	2,8	4,0	5,0	5,6	6,3
600		3,2	4,5	6,3	8,0	9,6	10,0
800		4,0	5,6	8,0	10,0	11,0	12,5
1000	5,0	7,1	10,0	12,5	14,0	16,0	

1) No minimum CREEPAGE DISTANCE is specified for insulation in Pollution Degree 1. However, the minimum CLEARANCE, as previously determined in 2.10.3 or annex G, still applies.

2) Linear interpolation is permitted between the nearest two points, the calculated spacing being rounded to the next higher 0,1 mm increment.

Compliance is checked by measurement, taking into account annex F.

The following conditions are applicable.

Movable parts are placed in their most unfavourable positions.

For equipment incorporating ordinary NON-DETACHABLE POWER SUPPLY CORDS, CREEPAGE DISTANCE measurements are made with supply conductors of the largest cross-sectional area specified in 3.3.4, and also without conductors.

When measuring CREEPAGE DISTANCES from an ENCLOSURE of insulating material through a slot or opening in the ENCLOSURE, the accessible surface is considered to be conductive as if it were covered by metal foil wherever it can be touched by the test finger, figure 2A (see 2.1.1.1), applied without appreciable force (see figure F.12, point B).

2.10.5 Solid insulation

The adequacy of solid insulation is verified by electric strength tests according to 5.2.

NOTE 1 The term "solid insulation" refers to material that provides electrical insulation between two opposite surfaces, not along an outer surface. Its required properties are specified either as the actual minimum distance through the insulation (see 2.10.5.1), or by other requirements and tests in this standard instead of a minimum distance.

NOTE 2 See also 3.1.4.

2.10.5.1 Minimum distance through insulation

Except where 2.1.1.3 or another subclause of 2.10.5 applies, distances through insulation shall be dimensioned according to PEAK WORKING VOLTAGE and to the application of the insulation (see 2.9) and as follows:

- if the PEAK WORKING VOLTAGE does not exceed 71 V, there is no requirement for distance through insulation;
- if the PEAK WORKING VOLTAGE exceeds 71 V, the following rules apply:
 - for FUNCTIONAL INSULATION and BASIC INSULATION there is no requirement at any PEAK WORKING VOLTAGE for distance through insulation;
 - SUPPLEMENTARY INSULATION or REINFORCED INSULATION shall have a minimum distance through insulation of 0,4 mm.

The requirements of 2.10.5.1 also apply to gel dielectrics such as are used in some opto-couplers.

There is no distance through insulation requirement for SUPPLEMENTARY INSULATION or REINFORCED INSULATION consisting of an insulating compound completely filling the casing of a semiconductor component (for example, an opto-coupler), so that CLEARANCES and CREEPAGE DISTANCES do not exist, if the component:

- passes the tests and inspection criteria of 2.10.8; and
- is subjected to ROUTINE TESTS for electric strength during manufacturing, using the appropriate value of the test voltage in 5.2.2.

Compliance is checked by inspection, measurement and test.

2.10.5.2 Thin sheet material

NOTE The requirements for wound components are given in 2.10.5.4.

Insulation in thin sheet materials is permitted, irrespective of its thickness, provided that it is used within the equipment ENCLOSURE and is not subject to handling or abrasion during OPERATOR servicing, and one of the following applies:

- SUPPLEMENTARY INSULATION comprises at least two layers of material, each of which will pass the electric strength test for SUPPLEMENTARY INSULATION; or
- SUPPLEMENTARY INSULATION comprises three layers of material for which all combinations of two layers together will pass the electric strength test for SUPPLEMENTARY INSULATION; or
- REINFORCED INSULATION comprises at least two layers of material, each of which will pass the electric strength test for REINFORCED INSULATION; or
- REINFORCED INSULATION comprises three layers of material for which all combinations of two layers together will pass the electric strength test for REINFORCED INSULATION.

There is no requirement for all layers of insulation to be of the same material.

Solvent-based enamel coatings are not considered to be insulation in thin sheet material.

Compliance is checked by inspection and by an electric strength test.

2.10.5.3 Printed boards

For the inner layers of multi-layer boards, the distance between two adjacent tracks on the same layer of a printed board is treated as distance through insulation (see 2.10.5.1).

SUPPLEMENTARY INSULATION or REINFORCED INSULATION between conductive layers in double-sided, single-layer printed boards, multi-layer printed boards and metal core printed boards, shall have a minimum thickness of 0,4 mm or meet the requirements according to table 2M.

Table 2M – Insulation in printed boards

Insulation	TYPE TESTS ¹⁾	ROUTINE TESTS for electric strength ³⁾
Two layers of sheet insulating material including pre-preg ²⁾	No	Yes
Three or more layers of sheet insulating material including pre-preg ²⁾	No	No
A ceramic coating that is cured at ≥ 500 °C	No	Yes
An insulation system, with two or more coatings, that is cured at < 500 °C	Yes	Yes
¹⁾ Thermal ageing and thermal cycling of 2.10.6 followed by the electric strength test of 5.2.2. ²⁾ Layers of pre-preg are counted before curing. ³⁾ Electric strength testing is carried out on the finished printed board. NOTE Pre-preg is the term used for a layer of glass cloth impregnated with a partially cured resin.		

Compliance is checked by inspection and measurement and by electric strength tests.

Where ROUTINE TESTS are required, the test voltage is the relevant test voltage of 5.2.2. The electric strength tests apply to the overall SUPPLEMENTARY INSULATION or REINFORCED INSULATION.

2.10.5.4 Wound components

Where BASIC INSULATION, SUPPLEMENTARY INSULATION or REINFORCED INSULATION is required between windings, they shall be separated by interleaved insulation complying with 2.10.5.1 or 2.10.5.2, or both, unless one of the following wire constructions a), b) or c) is used.

- a) Wire that has insulation, other than solvent-based enamel, complying with 2.10.5.1.
- b) Wire that has multi-layer extruded or spirally wrapped insulation (where the layers can be individually tested for electric strength) complying with 2.10.5.2 and passes the tests of annex U.
- c) Wire that has multi-layer extruded or spirally wrapped insulation (where only the finished wire can be tested) and passes the tests of annex U.

NOTE 1 See also 6.2.1.

In 2.10.5.4 c), the minimum number of constructional layers applied to the conductor shall be as follows:

- BASIC INSULATION: two wrapped layers or one extruded layer;
- SUPPLEMENTARY INSULATION: two layers, wrapped or extruded;
- REINFORCED INSULATION: three layers, wrapped or extruded.

In 2.10.5.4 b) and 2.10.5.4 c), for spirally wrapped insulation where the CREEPAGE DISTANCES between layers, as wrapped, are less than those given in table 2L for Pollution Degree 1, the path between layers shall be sealed as for a cemented joint in 2.10.8 and the test voltages of the TYPE TESTS in clause U.2 are increased to 1,6 times their normal values.

NOTE 2 One layer of material wound with more than 50 % overlap is considered to constitute two layers.

Where two insulated wires or one bare and one insulated wire are in contact inside the wound component, crossing each other at an angle between 45° and 90° and subject to winding tension, protection against mechanical stress shall be provided. This protection can be achieved, for example, by providing physical separation in the form of insulating sleeving or sheet material, or by using double the required number of insulation layers.

The finished component shall pass ROUTINE TESTS for electric strength using the appropriate test voltages in 5.2.2.

Compliance is checked by inspection and measurement and, if applicable, as specified in annex U. However, the tests of annex U are not repeated if the material data sheets confirm compliance.

2.10.6 Coated printed boards

2.10.6.1 General

For printed boards whose surface conductors are coated with a suitable coating material, the minimum separation distances of table 2N are applicable to conductors before they are coated, subject to the following requirements.

Either one or both conductive parts and at least 80 % of the distances over the surface between the conductive parts shall be coated. Between any two uncoated conductive parts and over the outside of the coating, the minimum distances in tables 2H, 2J or 2K apply.

The values in table 2N shall be used only if manufacturing is subject to a quality control programme that provides at least the same level of assurance as the example given in clause R.1. In particular, DOUBLE INSULATION and REINFORCED INSULATION shall pass ROUTINE TESTS for electric strength.

In default of the above conditions, the requirements of 2.10.1, 2.10.2, 2.10.3 or annex G, and 2.10.4 shall apply.

The coating process, the coating material and the base material shall be such that uniform quality is assured and the separation distances under consideration are effectively protected.

Compliance is checked by measurement taking into account figure F.11, and by the following tests.

2.10.6.2 Sample preparation and preliminary inspection

Three sample boards (or, for 2.10.9, two components and one board) identified as samples 1, 2 and 3 are required. It is permitted to use either actual boards or specially produced samples with representative coating and minimum separations. Each sample board shall be representative of the minimum separations used, and coated. Each sample is subjected to the full sequence of manufacturing processes, including soldering and cleaning, to which it is normally subjected during equipment assembly.

When visually inspected, the boards shall show no evidence of pinholes or bubbles in the coating or breakthrough of conductive tracks at corners.

Table 2N – Minimum separation distances for coated printed boards

WORKING VOLTAGE V r.m.s. or d.c.		FUNCTIONAL, BASIC or SUPPLEMENTARY INSULATION mm	REINFORCED INSULATION mm
	Up to and including 63	0,1	0,2
Over	63 up to and including 125	0,2	0,4
Over	125 up to and including 160	0,3	0,6
Over	160 up to and including 200	0,4	0,8
Over	200 up to and including 250	0,6	1,2
Over	250 up to and including 320	0,8	1,6
Over	320 up to and including 400	1,0	2,0
Over	400 up to and including 500	1,3	2,6
Over	500 up to and including 630	1,8	3,6
Over	630 up to and including 800	2,4	3,8
Over	800 up to and including 1 000	2,8	4,0
Over	1 000 up to and including 1 250	3,4	4,2
Over	1 250 up to and including 1 600	4,1	4,6
Over	1 600 up to and including 2 000	5,0	5,0
Over	2 000 up to and including 2 500	6,3	6,3
Over	2 500 up to and including 3 200	8,2	8,2
Over	3 200 up to and including 4 000	10	10
Over	4 000 up to and including 5 000	13	13
Over	5 000 up to and including 6 300	16	16
Over	6 300 up to and including 8 000	20	20
Over	8 000 up to and including 10 000	26	26
Over	10 000 up to and including 12 500	33	33
Over	12 500 up to and including 16 000	43	43
Over	16 000 up to and including 20 000	55	55
Over	20 000 up to and including 25 000	70	70
Over	25 000 up to and including 30 000	86	86

For voltages between 2 000 V and 30 000 V, linear interpolation is permitted between the nearest two points, the calculated spacing being rounded up to the next higher 0,1 mm increment.

2.10.6.3 Thermal cycling

Sample 1 is subjected 10 times to the following sequence of temperature cycles:

68 h at $T_1 \pm 2 \text{ }^\circ\text{C}$;

1 h at $25 \text{ }^\circ\text{C} \pm 2 \text{ }^\circ\text{C}$;

2 h at $0 \text{ }^\circ\text{C} \pm 2 \text{ }^\circ\text{C}$;

not less than 1 h at $25 \text{ }^\circ\text{C} \pm 2 \text{ }^\circ\text{C}$.

$T_1 = T_2 + T_{ma} - T_{amb} + 10 \text{ K}$, measured in accordance with 1.4.5 and, where relevant, 1.4.13, or $100 \text{ }^\circ\text{C}$, whichever is higher. However, the 10 K margin is not added if the temperature is measured by an embedded thermocouple.

T_2 is the temperature of the parts measured during the test of 4.5.1.

The significance of T_{ma} and T_{amb} is as given in 1.4.12.1.

The period of time taken for the transition from one temperature to another is not specified, but the transition is permitted to be gradual.

2.10.6.4 Thermal ageing

Sample 2 shall be aged in a full draught oven at a temperature and for a time duration chosen from the graph of figure 2G using the temperature index line that corresponds to the maximum operating temperature of the coated board. The temperature of the oven shall be maintained at the specified temperature $\pm 2 \text{ }^\circ\text{C}$. The temperature used to determine the temperature index line is the highest temperature on the board where safety is involved.

When using figure 2G, interpolation is permitted between the nearest two temperature index lines.

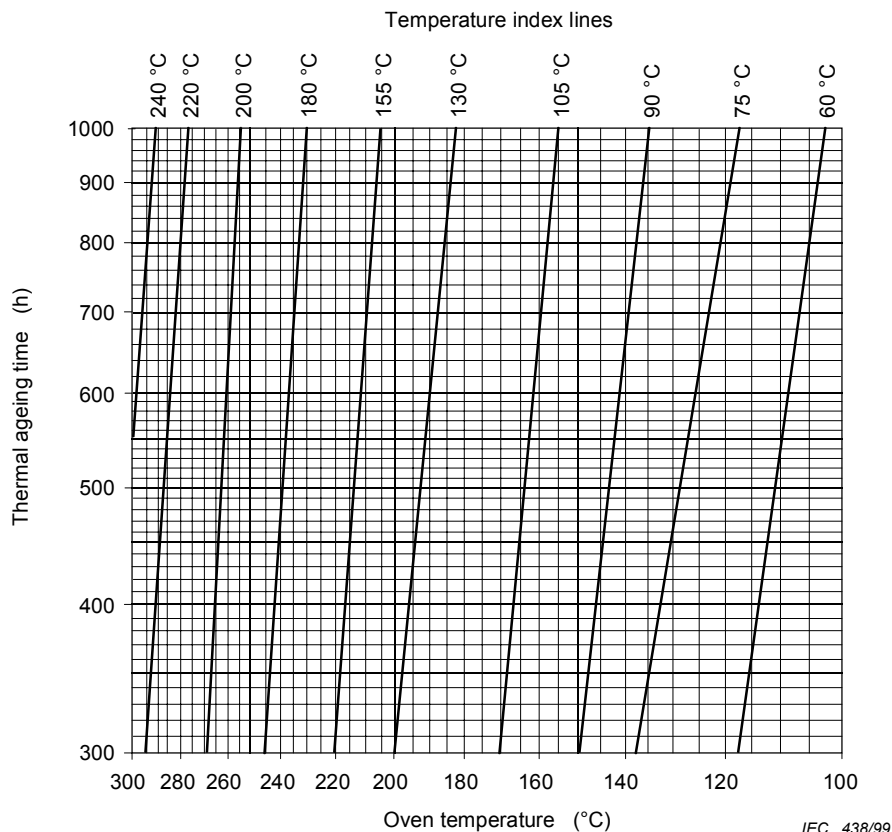

Figure 2G – Thermal ageing time

2.10.6.5 Electric strength test

Samples 1 and 2 are then subjected to the humidity conditioning of 2.9.2 (48 h) and shall withstand the relevant electric strength test of 5.2.2 between conductors.

2.10.6.6 Abrasion resistance test

Sample board 3 is subjected to the following test.

Scratches are made across five pairs of conducting parts and the intervening separations at points where the separations will be subject to the maximum potential gradient during the tests.

The scratches are made by means of a hardened steel pin, the end of which has the form of a cone having a tip angle of 40° , its tip being rounded and polished, with a radius of $0,25 \text{ mm} \pm 0,02 \text{ mm}$.

Scratches are made by drawing the pin along the surface in a plane perpendicular to the conductor edges at a speed of $20 \text{ mm/s} \pm 5 \text{ mm/s}$ as shown in figure 2H. The pin is so loaded that the force exerted along its axis is $10 \text{ N} \pm 0,5 \text{ N}$. The scratches shall be at least 5 mm apart and at least 5 mm from the edge of the specimen.

After this test, the coating layer shall neither have loosened nor have been pierced, and it shall withstand an electric strength test as specified in 5.2.2 between conductors. In the case of metal core printed boards, the substrate is one of the conductors.

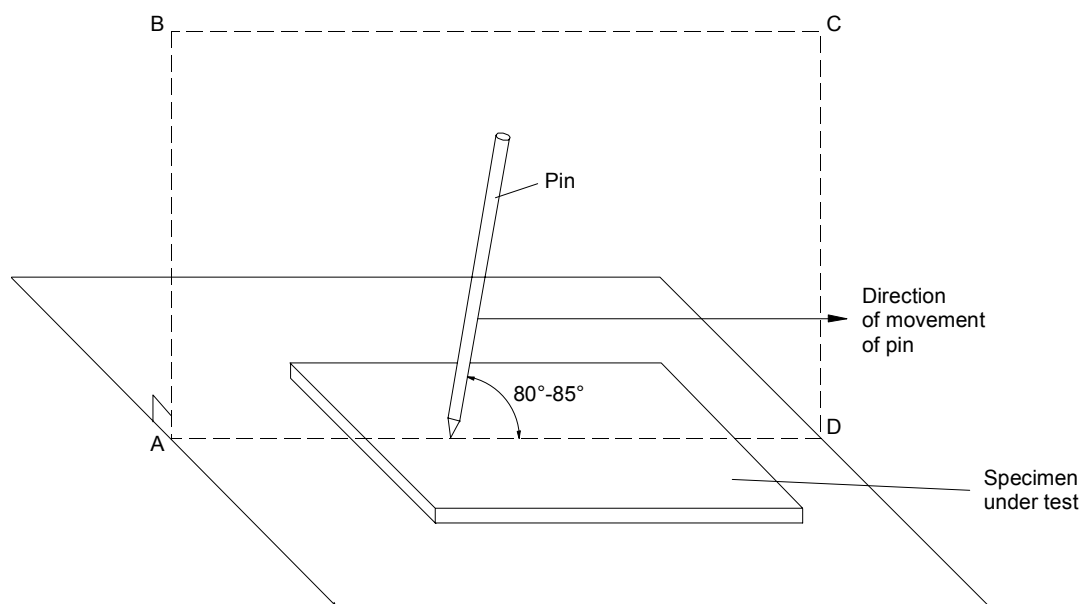

IEC 439/99

NOTE The pin is in the plane ABCD which is perpendicular to the specimen under test.

Figure 2H – Abrasion resistance test for coating layers

2.10.7 Enclosed and sealed parts

For components or subassemblies which are adequately enclosed by enveloping or hermetic sealing to prevent ingress of dirt and moisture, the values for Pollution Degree 1 apply to internal CLEARANCES and CREEPAGE DISTANCES.

NOTE Some examples of such construction include parts in boxes that are hermetically sealed by adhesive or otherwise, and parts enveloped in a dip coat.

Compliance is checked by inspection from the outside, measurement and, if necessary, by test. A component or subassembly is considered to be adequately enclosed if a sample passes the following sequence of tests.

The sample is subjected 10 times to the following sequence of temperature cycles:

68 h at $T_1 \pm 2\text{ °C}$;

1 h at $25\text{ °C} \pm 2\text{ °C}$;

2 h at $0\text{ °C} \pm 2\text{ °C}$;

not less than 1 h at $25\text{ °C} \pm 2\text{ °C}$.

$T_1 = T_2 + T_{ma} - T_{amb} + 10\text{ K}$, measured in accordance with 1.4.5 and, where relevant, 1.4.13, or 85 °C , whichever is higher. However, the 10 K margin is not added if the temperature is measured by an embedded thermocouple or by the resistance method.

T_2 is the temperature of the parts measured during the test of 4.5.1.

The significance of T_{ma} and T_{amb} is as given in 1.4.12.1.

The period of time taken for the transition from one temperature to another is not specified, but the transition is permitted to be gradual.

The sample is allowed to cool to room temperature and is subjected to the humidity conditioning of 2.9.2, followed immediately by the electric strength tests of 5.2.2.

For transformers, magnetic couplers and similar devices, where insulation is relied upon for safety, a voltage of 500 V r.m.s. at 50 Hz to 60 Hz is applied between windings during the thermal cycling conditioning. No evidence of insulation breakdown shall occur during this test.

2.10.8 Spacings filled by insulating compound

Where distances between conductive parts are filled with insulating compound, including where insulation is reliably cemented together with insulating compound, so that CLEARANCES and CREEPAGE DISTANCES do not exist, only the requirements for distance through insulation of 2.10.5.1 apply.

NOTE Some examples of such treatment are variously known as potting, encapsulation and vacuum impregnation.

Compliance is checked by inspection, measurement and test. There is no measurement of CLEARANCES and CREEPAGE DISTANCES if samples pass the thermal cycling, humidity conditioning and electric strength tests specified in 2.10.7, applied as follows:

- *for components where insulating compound forms solid insulation between conductive parts, a single finished component is tested. The tests are followed by inspection, including sectioning, and measurement. There shall be neither cracks nor voids in the insulating compound such as would affect compliance with 2.10.5.1.*
- *for components where insulating compound forms a cemented joint with other insulating parts, the reliability of the joint is checked by subjecting three samples to the electric strength tests applied directly to the cemented joint. If a winding of solvent-based enamelled wire is used in the component, it is replaced for the test by a metal foil or by a few turns of bare wire, placed close to the cemented joint. The three samples are then tested as follows:*
 - *one of the samples is subjected to the relevant electric strength test of 5.2.2, immediately after the last period at highest temperature during thermal cycling, except that the test voltage is multiplied by 1,6;*
 - *the other samples are subjected to the relevant electric strength test of 5.2.2 after the humidity conditioning, except that the test voltage is multiplied by 1,6.*

2.10.9 Component external terminations

The requirements of 2.10.1, 2.10.2, 2.10.3 or annex G, and 2.10.4 are applicable to the spacings between external terminations of components unless they have a coating of material satisfying the requirements of 2.10.6 including the quality control requirements, an example of which is given in clause R.1. In such a case, the minimum separation distances of table 2N (see 2.10.6.1) apply to the component before coating. Between any two uncoated conductive parts and over the outside of the coating, the minimum CLEARANCE of 2.10.3 or annex G and the minimum CREEPAGE DISTANCE of 2.10.4 shall be applied.

If coatings are used over terminations to increase effective CREEPAGE DISTANCES and CLEARANCES, the mechanical arrangement and rigidity of the terminations shall be adequate to ensure that, during normal handling, assembly into equipment and subsequent use, the terminations will not be subject to deformation which would crack the coating or reduce the separation distances between conductive parts below the values in table 2N (see 2.10.6.1).

Compliance is checked by inspection taking into account figure F.10, and by applying the sequence covered by 2.10.6.2, 2.10.6.3, 2.10.6.4 and 2.10.6.5. This test is carried out on a completed assembly including the component(s).

The abrasion resistance test of 2.10.6.6 is carried out on a specially prepared sample printed board as described for sample 3 in 2.10.6.2, except that the separation between the conductive parts shall be representative of the minimum separations and maximum potential gradients used in the assembly.

2.10.10 Insulation with varying dimensions

If the insulation of a transformer has different WORKING VOLTAGES along the length of the winding, it is permitted to vary CLEARANCES, CREEPAGE DISTANCES and distances through insulation accordingly.

NOTE An example of such a construction is a 30 kV winding, consisting of multiple bobbins connected in series, and earthed at one end.

3 Wiring, connections and supply

3.1 General

3.1.1 Current rating and overcurrent protection

The cross-sectional area of internal wires and INTERCONNECTING CABLES shall be adequate for the current they are intended to carry when the equipment is operating under NORMAL LOAD such that the maximum permitted temperature of conductor insulation is not exceeded.

All internal wiring (including busbars) and INTERCONNECTING CABLES used in the distribution of PRIMARY CIRCUIT power shall be protected against overcurrent and short circuit by suitably rated protective devices.

Wiring not directly involved in the distribution path does not require protection if it can be shown that creation of hazards is unlikely (for example, indicating circuits).

NOTE 1 Devices for overload protection of components may also provide protection of associated wiring.

NOTE 2 Internal circuits connected to an AC MAINS SUPPLY or to a DC MAINS SUPPLY may require individual protection depending on reduced wire size and length of conductors.

Compliance is checked by inspection and, as appropriate, by the tests of 4.5.1.

3.1.2 Protection against mechanical damage

Wireways shall be smooth and free from sharp edges. Wires shall be protected so that they do not come into contact with burrs, cooling fins, moving parts, etc., which could cause damage to the insulation of conductors. Holes in metal, through which insulated wires pass, shall have smooth well-rounded surfaces or shall be provided with bushings.

It is permitted for wires to be in close contact with wire wrapping posts and the like if any breakdown of insulation will not create a hazard, or if adequate mechanical protection is provided by the insulation system.

Compliance is checked by inspection.

3.1.3 Securing of internal wiring

Internal wiring shall be routed, supported, clamped or secured in a manner that reduces the likelihood of:

- excessive strain on wire and on terminal connections; and
- loosening of terminal connections; and
- damage of conductor insulation.

Compliance is checked by inspection.

3.1.4 Insulation of conductors

Except as covered in 2.1.1.3 b), insulation of individual conductors of internal wiring shall fulfil the requirements of 2.10.5 and be capable of withstanding the applicable electric strength test specified in 5.2.2.

Where a power supply cord, whose insulating properties comply with those of the cord types of 3.2.5, is used inside the equipment, either as an extension of the external power supply cord or as an independent cable, the sheath of the power supply cord is considered to be adequate SUPPLEMENTARY INSULATION for the purpose of 3.1.4.

NOTE Requirements regarding colours of insulation are in 2.6.3.4.

Compliance is checked by inspection and evaluation of test data showing that the insulation withstands the relevant test voltage.

If such applicable test data is not available, compliance is checked by applying the electric strength test using a sample of approximately 1 m in length and by applying the relevant test voltage as follows:

- *for insulation of a conductor: by the voltage test method given in clause 3 of IEC 60885-1, using the relevant test voltage in 5.2.2 in this standard for the grade of insulation under consideration; and*
- *for SUPPLEMENTARY INSULATION (for example, sleeving around a group of conductors): between a conductor inserted into the sleeve and metal foil wrapped tightly round the sleeve for a length of at least 100 mm.*

3.1.5 Beads and ceramic insulators

Beads and similar ceramic insulators on conductors shall:

- be so fixed or supported that they cannot change their position in such a way that a hazard would be created; and
- not rest on sharp edges or sharp corners.

If beads are located inside flexible metal conduits, they shall be contained within an insulating sleeve, unless the conduit is mounted or secured in such a way that movement in normal use would not create a hazard.

Compliance is checked by inspection and, where necessary, by the following test.

A force of 10 N is applied to the insulators or to the conduit. The resulting movement, if any, shall not create a hazard in the meaning of this standard.

3.1.6 Screws for electrical contact pressure

Where electrical contact pressure is required, a screw shall engage at least two complete threads into a metal plate, a metal nut or a metal insert.

Screws of insulating material shall not be used where electrical connections, including protective earthing, are involved, or where their replacement by metal screws could impair SUPPLEMENTARY INSULATION or REINFORCED INSULATION.

Where screws of insulating material contribute to other safety aspects, they shall be engaged by at least two complete threads.

NOTE See also 2.6.5.7 for screws used for protective earthing continuity.

Compliance is checked by inspection.

3.1.7 Insulating materials in electrical connections

Electrical connections, including those for protective earthing functions (see 2.6), shall be so designed that contact pressure is not transmitted through insulating material unless there is sufficient resilience in the metallic parts to compensate for any possible shrinkage or distortion of the insulating material.

Compliance is checked by inspection.

3.1.8 Self-tapping and spaced thread screws

Spaced thread (sheet metal) screws shall not be used for the connection of current-carrying parts, unless they clamp these parts directly in contact with each other and are provided with a suitable means of locking.

Self-tapping (thread-cutting or thread-forming) screws shall not be used for the electrical connection of current-carrying parts, unless they generate a full form standard machine screw thread. Moreover, such screws shall not be used if they are operated by the USER or installer unless the thread is formed by a swaging action.

NOTE See also 2.6.5.7 for screws used for protective earthing continuity.

Compliance is checked by inspection.

3.1.9 Termination of conductors

Conductors shall be provided with a means (for example, barriers or fixing), or be so terminated, that they and their terminators (for example, ring terminals and flat quick-connect terminals) cannot, in normal use, become so displaced that CLEARANCES or CREEPAGE DISTANCES are reduced to less than the values specified in 2.10.

It is permitted to use soldered, welded, crimped, screwless (push-in) and similar terminations for the connection of conductors. For soldered terminations, the conductor shall be positioned or fixed so that reliance is not placed upon the soldering alone to maintain the conductor in position.

In multiway plugs and sockets, and wherever shorting could otherwise occur, means shall be provided to prevent contact between parts in SELV CIRCUITS or TNV CIRCUITS and parts at HAZARDOUS VOLTAGE due to loosening of a terminal or breaking of a wire at a termination.

Compliance is checked by inspection, by measurement and, where necessary, by the following test.

A force of 10 N is applied to the conductor near its termination point. The conductor shall not break away or pivot on its terminal to the extent that required CLEARANCE or CREEPAGE DISTANCES are reduced below the values required in 2.10.

For the purpose of assessing compliance it is assumed that:

- *two independent fixings will not become loose at the same time; and*
- *parts fixed by means of screws or nuts provided with self-locking washers or other means of locking are not liable to become loose.*

NOTE Spring washers and the like can provide satisfactory locking.

Examples of constructions regarded as meeting the requirements include:

- *close-fitting tubing (for example, a heat shrink or synthetic rubber sleeve), applied over the wire and its termination;*
- *conductors connected by soldering and held in place near to the termination, independently of the soldered connection;*
- *conductors connected by soldering and "hooked in" before soldering, provided that the hole through which the conductor is passed is not unduly large;*
- *conductors connected to screw terminals, with an additional fixing near to the terminal that clamps, in the case of stranded conductors, the insulation and not only the conductors;*
- *conductors connected to screw terminals and provided with terminators which are unlikely to become free (for example, ring lugs crimped onto the conductors). The pivoting of such terminators is considered;*
- *short rigid conductors that remain in position when the terminal screw is loosened.*

3.1.10 Sleeving on wiring

Where sleeving is used as SUPPLEMENTARY INSULATION on internal wiring, it shall be retained in position by positive means.

Compliance is checked by inspection.

Examples of constructions that are considered to meet the intent of this requirement include:

- *sleeving that can be removed only by breaking or cutting of either the wiring or sleeving;*
- *sleeving that is clamped at both ends;*
- *heat shrinkable sleeving that tightens against the wire insulation;*
- *sleeving that is of such length that it will not slip.*

3.2 Connection to an a.c. mains supply or a d.c. mains supply

3.2.1 Means of connection

3.2.1.1 Connection to an a.c. mains supply

For safe and reliable connection to an AC MAINS SUPPLY, equipment shall be provided with one of the following:

- terminals for permanent connection to the supply;
- a NON-DETACHABLE POWER SUPPLY CORD for permanent connection to the supply, or for connection to the supply by means of a plug;

NOTE In the United Kingdom, it is required to fit a plug conforming to BS 1363 to the power cord of certain equipment.

- an appliance inlet for connection of a DETACHABLE POWER SUPPLY CORD;
- a mains plug that is part of DIRECT PLUG-IN EQUIPMENT.

Compliance is checked by inspection.

3.2.1.2 Connection to a d.c. mains supply

For safe and reliable connection to a DC MAINS SUPPLY, equipment shall be provided with one of the following:

- terminals for permanent connection to the supply;
- a NON-DETACHABLE POWER SUPPLY CORD for permanent connection to the supply, or for connection to the supply by means of a plug;
- an appliance inlet for connection of a DETACHABLE POWER SUPPLY CORD.

Plugs and appliance inlets shall not be of a type that is used for AC MAINS SUPPLIES if a hazard could be created by their use. Plugs and appliance inlets shall be so designed that reverse polarity connections are prevented if a hazard could be created by such connection.

It is permitted for one pole of the DC MAINS SUPPLY to be connected both to an equipment mains input terminal and to the main protective earthing terminal of the equipment, if any, provided the equipment installation instructions detail the proper earthing for the system.

Compliance is checked by inspection.

3.2.2 Multiple supply connections

If equipment is provided with more than one supply connection (for example, with different voltages or frequencies or as backup power), the design shall be such that all of the following conditions are met:

- separate means of connection are provided for different circuits; and
- supply plug connections, if any, are not interchangeable if a hazard could be created by incorrect plugging; and
- bare parts of an ELV CIRCUIT or parts at HAZARDOUS VOLTAGES, such as plug contacts, are not accessible to an OPERATOR when one or more connectors are disconnected.

Compliance is checked by inspection and for accessibility, where necessary, by a test with the test finger, figure 2A (see 2.1.1.1).

3.2.3 Permanently connected equipment

PERMANENTLY CONNECTED EQUIPMENT shall be provided with either:

- a set of terminals as specified in 3.3; or
- a NON-DETACHABLE POWER SUPPLY CORD.

PERMANENTLY CONNECTED EQUIPMENT having a set of terminals shall:

- permit the connection of the supply wires after the equipment has been fixed to its support; and
- be provided with cable entries, conduit entries, knock-outs or glands, which allow connection of the appropriate types of cables or conduits.

For equipment having a RATED CURRENT not exceeding 16 A, the cable entries shall be suitable for cables and conduits having an overall diameter as shown in table 3A.

NOTE 1 In Canada and the United States the dimensions in parentheses are the size of conduit opening required for terminating nominal 1/2 inch and 3/4 inch trade size conduits.

NOTE 2 In Australia, additional requirements apply.

Conduit and cable entries and knock-outs for supply connections shall be so designed or located that the introduction of the conduit and cable does not affect the protection against electric shock, or reduce CLEARANCES and CREEPAGE DISTANCES below the values specified in 2.10.

Compliance is checked by inspection, by a practical installation test and by measurement.

Table 3A – Sizes of cables and conduits for equipment having a rated current not exceeding 16 A

Number of conductors, including the PROTECTIVE EARTHING CONDUCTOR where provided	Overall diameter mm	
	Cable	Conduit
2	13,0	16,0 (22,2)
3	14,0	16,0 (22,2)
4	14,5	20,0 (27,8)
5	15,5	20,0 (27,8)

3.2.4 Appliance inlets

Appliance inlets shall meet all of the following:

- be so located or enclosed that parts at HAZARDOUS VOLTAGE are not accessible during insertion or removal of the connector (appliance inlets complying with IEC 60309 or with IEC 60320 are considered to comply with this requirement); and
- be so located that the connector can be inserted without difficulty; and
- be so located that, after insertion of the connector, the equipment is not supported by the connector for any position of normal use on a flat surface.

Compliance is checked by inspection and, for accessibility, by means of the test finger, figure 2A (see 2.1.1.1).

3.2.5 Power supply cords

3.2.5.1 AC power supply cords

A power supply cord for connection to the AC MAINS SUPPLY shall comply with all of the following, as appropriate:

- if rubber insulated, be of synthetic rubber and not lighter than ordinary tough rubber-sheathed flexible cord according to IEC 60245 (designation 60245 IEC 53); and
- if PVC insulated:
 - for equipment provided with a NON-DETACHABLE POWER SUPPLY CORD and having a mass not exceeding 3 kg, be not lighter than light PVC sheathed flexible cord according to IEC 60227 (designation 60227 IEC 52);
 - for equipment provided with a NON-DETACHABLE POWER SUPPLY CORD and having a mass exceeding 3 kg, be not lighter than ordinary PVC sheathed flexible cord according to IEC 60227 (designation 60227 IEC 53);
 - for equipment provided with a DETACHABLE POWER SUPPLY CORD, be not lighter than light PVC sheathed flexible cord according to IEC 60227 (designation 60227 IEC 52); and

NOTE 1 There is no limit on the mass of the equipment if the equipment is intended for use with a DETACHABLE POWER SUPPLY CORD.

- include, for equipment required to have protective earthing, a PROTECTIVE EARTHING CONDUCTOR having green-and-yellow insulation; and
- have conductors with cross-sectional areas not less than those specified in table 3B.

NOTE 2 In Australia, additional requirements apply.

Compliance is checked by inspection and by measurement. In addition, for screened cords, compliance is checked by the tests of IEC 60227 (all parts). However, flexing tests need be applied only to screened power supply cords for MOVABLE EQUIPMENT.

NOTE 3 Although screened cords are not covered in the scope of IEC 60227 (all parts), the relevant tests of IEC 60227 (all parts) are used.

Damage to the screen is acceptable provided that:

- *during the flexing test the screen does not make contact with any conductor, and*
- *after the flexing test, the sample withstands the electric strength test between the screen and all other conductors.*

Table 3B – Sizes of conductors

RATED CURRENT of equipment A	Minimum conductor sizes	
	Nominal cross-sectional area mm ²	AWG or kcmil [cross-sectional area in mm ²] see note 2
Up to and including 6	0,75 ¹⁾	18 [0,8]
Over 6 up to and including 10	(0,75) ²⁾	16 [1,3]
Over 10 up to and including 13	(1,0) ³⁾	16 [1,3]
Over 13 up to and including 16	(1,0) ³⁾	14 [2]
Over 16 up to and including 25	2,5	12 [3]
Over 25 up to and including 32	4	10 [5]
Over 32 up to and including 40	6	8 [8]
Over 40 up to and including 63	10	6 [13]
Over 63 up to and including 80	16	4 [21]
Over 80 up to and including 100	25	2 [33]
Over 100 up to and including 125	35	1 [42]
Over 125 up to and including 160	50	0 [53]
Over 160 up to and including 190	70	000 [85]
Over 190 up to and including 230	95	0000 [107]
Over 230 up to and including 260	120	250 kcmil [126]
Over 260 up to and including 300	150	300 kcmil [152]
Over 300 up to and including 340	185	400 kcmil [202]
Over 340 up to and including 400	240	500 kcmil [253]
Over 400 up to and including 460	300	600 kcmil [304]

1) For RATED CURRENT up to 3 A, a nominal cross-sectional area of 0,5 mm² is permitted in some countries provided that the length of the cord does not exceed 2 m.

2) The value in parentheses applies to DETACHABLE POWER SUPPLY CORDS fitted with the connectors rated 10 A in accordance with IEC 60320 (types C13, C15, C15A and C17) provided that the length of the cord does not exceed 2 m.

3) The value in parentheses applies to DETACHABLE POWER SUPPLY CORDS fitted with the connectors rated 16 A in accordance with IEC 60320 (types C19, C21 and C23) provided that the length of the cord does not exceed 2 m.

NOTE 1 IEC 60320 specifies acceptable combinations of appliance couplers and flexible cords, including those covered by items 1), 2) and 3). However, a number of countries have indicated that they do not accept all of the values listed in table 3B, particularly those covered by items 1), 2) and 3).

NOTE 2 AWG and kcmil sizes are provided for information only. The associated cross-sectional areas, in square brackets, have been rounded to show significant figures only. AWG refers to the American Wire Gage and the term "cmil" refers to circular mils where one circular mil is equal to the area of a circle having a diameter of one mil (one thousandth of an inch). These terms are commonly used to designate wire sizes in North America.

3.2.5.2 DC power supply cords

A power supply cord for connection to the DC MAINS SUPPLY shall be suitable for the voltage, current and the physical abuses it is likely to encounter.

Compliance is checked by inspection.

3.2.6 Cord anchorages and strain relief

For equipment with a NON-DETACHABLE POWER SUPPLY CORD, a cord anchorage shall be supplied such that:

- the connecting points of the cord conductors are relieved from strain; and
- the outer covering of the cord is protected from abrasion.

It shall not be possible to push the cord back into the equipment to such an extent that the cord or its conductors, or both, could be damaged or internal parts of the equipment could be displaced.

For NON-DETACHABLE POWER SUPPLY CORDS containing a PROTECTIVE EARTHING CONDUCTOR, the construction shall be such that if the cord should slip in its anchorage, placing a strain on conductors, the PROTECTIVE EARTHING CONDUCTOR will be the last to take the strain.

The cord anchorage shall either be made of insulating material or have a lining of insulating material complying with the requirements for SUPPLEMENTARY INSULATION. However, where the cord anchorage is a bushing that includes the electrical connection to the screen of a screened power cord, this requirement shall not apply. The construction of the cord anchorage shall be such that:

- cord replacement does not impair the safety of the equipment; and
- for ordinary replacement cords, it is clear how relief from strain is to be obtained; and
- the cord is not clamped by a screw which bears directly on the cord, unless the cord anchorage, including the screw, is made of insulating material and the screw is of comparable size to the diameter of the cord being clamped; and
- methods such as tying the cord into a knot or tying the cord with a string are not used; and
- the cord cannot rotate in relation to the BODY of the equipment to such an extent that mechanical strain is imposed on the electrical connections.

Compliance is checked by inspection and by applying the following tests which are made with the type of power supply cord supplied with the equipment.

The cord is subjected to a steady pull of the value shown in table 3C, applied in the most unfavourable direction. The test is conducted 25 times, each time for a duration of 1 s.

During the tests, the power supply cord shall not be damaged. This is checked by visual inspection, and by an electric strength test between the power cord conductors and accessible conductive parts, at the test voltage appropriate for REINFORCED INSULATION.

After the tests, the power supply cord shall not have been longitudinally displaced by more than 2 mm nor shall there be appreciable strain at the connections, and CLEARANCES and CREEPAGE DISTANCES shall not be reduced below the values specified in 2.10.

Table 3C – Physical tests on power supply cords

Mass (M) of the equipment kg	Pull N
$M \leq 1$	30
$1 < M \leq 4$	60
$M > 4$	100

3.2.7 Protection against mechanical damage

Power supply cords shall not be exposed to sharp points or cutting edges within or on the surface of the equipment, or at the inlet opening or inlet bushing.

The overall sheath of a NON-DETACHABLE POWER SUPPLY CORD shall continue into the equipment through any inlet bushing or cord guard and shall extend by at least half the cord diameter beyond the clamp of the cord anchorage.

Inlet bushings, where used, shall:

- be reliably fixed; and
- not be removable without the use of a TOOL.

A metallic inlet bushing shall not be used in a non-metallic ENCLOSURE.

An inlet bushing or cord guard secured to a conductive part that is not protectively earthed shall meet the requirements for SUPPLEMENTARY INSULATION.

Compliance is checked by inspection and measurement.

3.2.8 Cord guards

A cord guard shall be provided at the power supply cord inlet opening of equipment which has a NON-DETACHABLE POWER SUPPLY CORD, and which is HAND-HELD EQUIPMENT or is intended to be moved while in operation. Alternatively, the inlet or bushing shall be provided with a smoothly rounded bell-mouthed opening having a radius of curvature equal to at least 1,5 times the overall diameter of the cord with the largest cross-sectional area to be connected.

Cord guards shall:

- be so designed as to protect the cord against excessive bending where it enters the equipment; and
- be of insulating material; and
- be fixed in a reliable manner; and
- project outside the equipment beyond the inlet opening for a distance of at least five times the overall diameter or, for flat cords, at least five times the major overall cross-sectional dimension of the cord.

Compliance is checked by inspection, by measurement and, where necessary, by the following test with the cord as delivered with the equipment.

The equipment is so placed that the axis of the cord guard, where the cord leaves it, projects at an angle of 45° when the cord is free from stress. A mass equal to $10 \times D^2$ g is then attached to the free end of the cord, where D is the overall diameter of, or for flat cords, the minor overall dimension of the cord, in millimetres.

If the cord guard is of temperature-sensitive material, the test is made at $23 \text{ °C} \pm 2 \text{ °C}$.

Flat cords are bent in the plane of least resistance.

Immediately after the mass has been attached, the radius of curvature of the cord shall nowhere be less than 1,5 D .

3.2.9 Supply wiring space

The supply wiring space provided inside, or as part of, the equipment for permanent connection or for connection of an ordinary NON-DETACHABLE POWER SUPPLY CORD shall be designed:

- to allow the conductors to be introduced and connected easily; and
- so that the uninsulated end of a conductor is unlikely to become free from its terminal, or, should it do so, cannot come into contact with:
 - an accessible conductive part that is not protectively earthed; or
 - an accessible conductive part of HAND-HELD EQUIPMENT; and
- to permit checking before fitting the cover, if any, that the conductors are correctly connected and positioned; and
- so that covers, if any, can be fitted without risk of damage to the supply conductors or their insulation; and
- so that covers, if any, giving access to the terminals can be removed with a commonly available TOOL.

Compliance is checked by inspection and by an installation test with cords of the largest cross-sectional area of the appropriate range specified in 3.3.4.

3.3 Wiring terminals for connection of external conductors

3.3.1 Wiring terminals

PERMANENTLY CONNECTED EQUIPMENT and equipment with ordinary NON-DETACHABLE POWER SUPPLY CORDS shall be provided with terminals in which connection is made by means of screws, nuts or equally effective devices (see also 2.6.4).

Compliance is checked by inspection.

3.3.2 Connection of non-detachable power supply cords

For equipment with special NON-DETACHABLE POWER SUPPLY CORDS, the connection of the individual conductors to the internal wiring of the equipment shall be accomplished by any means that will provide a reliable electrical and mechanical connection without exceeding the permitted temperature limits while the equipment is operated under NORMAL LOAD. (See also 3.1.9.)

Compliance is checked by inspection and by measuring the temperature of the connection which shall not exceed the values of 4.5.1.

3.3.3 Screw terminals

Screws and nuts which clamp external mains supply conductors shall have a thread conforming to ISO 261 or ISO 262, or a thread comparable in pitch and mechanical strength (for example, unified threads). The screws and nuts shall not serve to fix any other component, except that they are permitted also to clamp internal conductors provided that the internal conductors are so arranged that they are unlikely to be displaced when fitting the supply conductors. For protective earthing terminals, see also 2.6.4.2.

The terminals of a component (for example, a switch) built into the equipment are permitted for use as terminals for external mains supply conductors, provided that they comply with the requirements of 3.3.

Compliance is checked by inspection.

3.3.4 Conductor sizes to be connected

Terminals shall allow the connection of conductors having nominal cross-sectional areas as shown in table 3D.

Where heavier gauge conductors are used, the terminals shall be sized accordingly.

Compliance is checked by inspection, by measurement and by fitting cords of the smallest and largest cross-sectional areas of the appropriate range shown in table 3D.

Table 3D – Range of conductor sizes to be accepted by terminals

RATED CURRENT of equipment A	Nominal cross-sectional area mm ²	
	Flexible cords	Other cables
Up to and including 3	0,5 to 0,75	1 to 2,5
Over 3 up to and including 6	0,75 to 1	1 to 2,5
Over 6 up to and including 10	1 to 1,5	1 to 2,5
Over 10 up to and including 13	1,25 to 1,5	1,5 to 4
Over 13 up to and including 16	1,5 to 2,5	1,5 to 4
Over 16 up to and including 25	2,5 to 4	2,5 to 6
Over 25 up to and including 32	4 to 6	4 to 10
Over 32 up to and including 40	6 to 10	6 to 16
Over 40 up to and including 63	10 to 16	10 to 25

3.3.5 Wiring terminal sizes

Wiring terminals shall comply with the minimum sizes in table 3E.

Compliance is checked by inspection and measurement.

Table 3E – Sizes of terminals for mains supply conductors and protective earthing conductors ¹⁾

RATED CURRENT of equipment A	Minimum nominal thread diameter mm	
	Pillar type or stud type	Screw type ²⁾
Up to and including 10	3,0	3,5
Over 10 up to and including 16	3,5	4,0
Over 16 up to and including 25	4,0	5,0
Over 25 up to and including 32	4,0	5,0
Over 32 up to and including 40	5,0	5,0
Over 40 up to and including 63	6,0	6,0

¹⁾ This table is also used for the sizes of terminals for PROTECTIVE BONDING CONDUCTORS if specified in 2.6.4.2.

²⁾ "Screw type" refers to a terminal that clamps the conductor under the head of a screw, with or without a washer.

3.3.6 Wiring terminal design

Wiring terminals shall be so designed that they clamp the conductor between metal surfaces with sufficient contact pressure and without damage to the conductor.

Terminals shall be so designed or located that the conductor cannot slip out when the clamping screws or nuts are tightened.

Terminals shall be provided with appropriate fixing hardware for the conductors (for example, nuts and washers).

Terminals shall be so fixed that, when the means of clamping the conductor is tightened or loosened:

- the terminal itself does not work loose; and
- internal wiring is not subjected to stress; and
- CLEARANCES and CREEPAGE DISTANCES are not reduced below the values specified in 2.10.

Compliance is checked by inspection and measurement.

3.3.7 Grouping of wiring terminals

For ordinary NON-DETACHABLE POWER SUPPLY CORDS and for PERMANENTLY CONNECTED EQUIPMENT, all associated AC MAINS SUPPLY terminals shall be located in proximity to each other and to the main protective earthing terminal, if any.

For ordinary NON-DETACHABLE POWER SUPPLY CORDS and for PERMANENTLY CONNECTED EQUIPMENT, all associated DC MAINS SUPPLY terminals shall be located in proximity to each other. They need not be located in proximity to the main protective earthing terminal, if any, provided the installation instructions detail the proper earthing of the system.

Compliance is checked by inspection.

3.3.8 Stranded wire

The end of a stranded conductor shall not be consolidated by soft soldering at places where the conductor is subject to contact pressure unless the method of clamping is designed so as to reduce the likelihood of a bad contact due to cold flow of the solder.

Spring terminals that compensate for the cold flow are deemed to satisfy this requirement.

Preventing the clamping screws from rotating is not considered to be adequate.

Terminals shall be located, guarded or insulated so that, should a strand of a flexible conductor escape when the conductor is fitted, there is no likelihood of accidental contact between such a strand and:

- accessible conductive parts; or
- unearthed conductive parts separated from accessible conductive parts by SUPPLEMENTARY INSULATION only.

Compliance is checked by inspection and, unless a special cord is prepared in such a way as to prevent the escape of strands, by the following test.

A piece of insulation approximately 8 mm long is removed from the end of a flexible conductor having the appropriate nominal cross-sectional area. One wire of the stranded conductor is left free and the other wires are fully inserted into, and clamped in the terminal.

Without tearing the insulation back, the free wire is bent in every possible direction, but without making sharp bends around the guard.

If the conductor is at HAZARDOUS VOLTAGE, the free wire shall not touch any conductive part which is accessible or is connected to an accessible conductive part or, in the case of DOUBLE INSULATED equipment, any conductive part which is separated from accessible conductive parts by SUPPLEMENTARY INSULATION only.

If the conductor is connected to an earthing terminal, the free wire shall not touch any part at HAZARDOUS VOLTAGE.

3.4 Disconnection from the mains supply

3.4.1 General requirement

A disconnect device or devices shall be provided to disconnect the equipment from the mains supply for servicing.

NOTE Instructions may be provided to allow servicing parts of the equipment with or without opening the disconnect device.

Compliance is checked by inspection.

3.4.2 Disconnect devices

Disconnect devices shall have a contact separation of at least 3 mm and, when incorporated in the equipment, shall be connected as closely as practicable to the incoming supply.

Functional switches are permitted to serve as disconnect devices provided that they comply with all the requirements for disconnect devices. However, these requirements do not apply to functional switches where other means of isolation are provided.

The following types of disconnect devices are permitted:

- the plug on the power supply cord;
- a mains plug that is part of DIRECT PLUG-IN EQUIPMENT;
- an appliance coupler;
- an isolating switch;
- a circuit breaker;
- any equivalent device.

Compliance is checked by inspection.

3.4.3 Permanently connected equipment

For PERMANENTLY CONNECTED EQUIPMENT, the disconnect device shall be incorporated in the equipment, unless the equipment is accompanied by installation instructions in accordance with 1.7.2, stating that an appropriate disconnect device shall be provided as part of the building installation.

NOTE External disconnect devices will not necessarily be supplied with the equipment.

Compliance is checked by inspection.

3.4.4 Parts which remain energized

Parts on the supply side of a disconnect device in the equipment, which remain energized when the disconnect device is switched off, shall be guarded so as to reduce the likelihood of accidental contact by a SERVICE PERSON.

Compliance is checked by inspection.

3.4.5 Switches in flexible cords

Isolating switches shall not be fitted in flexible cords.

Compliance is checked by inspection.

3.4.6 Single-phase and d.c. equipment

For single-phase and d.c. equipment, the disconnect device shall disconnect both poles simultaneously, except that a single-pole disconnect device can be used to disconnect the line conductor where it is possible to rely on the identification of an earthed conductor in a DC MAINS SUPPLY or an earthed neutral in an AC MAINS SUPPLY.

For equipment provided with a single-pole disconnect device, the installation instructions shall specify that an additional two-pole disconnect device is to be provided in the building installation if the equipment is used where identification of an earthed conductor in a DC MAINS SUPPLY or an earthed neutral in an AC MAINS SUPPLY is not possible.

NOTE Three examples of cases where a two-pole disconnect device is required are:

- on equipment supplied from an IT power distribution system;
- on PLUGGABLE EQUIPMENT supplied through a reversible appliance coupler or a reversible plug (unless the appliance coupler or plug itself is used as the disconnect device);
- on equipment supplied from a socket-outlet with indeterminate polarity.

Compliance is checked by inspection.

3.4.7 Three-phase equipment

For three-phase equipment, the disconnect device shall disconnect simultaneously all line conductors of the AC MAINS SUPPLY.

For equipment requiring a neutral connection to an IT power distribution system, the disconnect device shall be a four-pole device and shall disconnect all line conductors and the neutral conductor. If this four-pole device is not provided in the equipment, the installation instructions shall specify the need for the provision of the device as part of the building installation.

If a disconnect device interrupts the neutral conductor, it shall simultaneously interrupt all line conductors.

Compliance is checked by inspection.

3.4.8 Switches as disconnect devices

Where the disconnect device is a switch incorporated in the equipment, its "ON" and "OFF" positions shall be marked in accordance with 1.7.8.

Compliance is checked by inspection.

3.4.9 Plugs as disconnect devices

Where a plug on the power supply cord is used as the disconnect device, the installation instructions shall comply with 1.7.2.

Compliance is checked by inspection.

3.4.10 Interconnected equipment

Where a group of units having individual supply connections is interconnected in such a way that it is possible for HAZARDOUS VOLTAGE or HAZARDOUS ENERGY LEVELS to be transmitted between units, a disconnect device shall be provided to disconnect hazardous parts likely to be contacted while the unit under consideration is being serviced, unless these parts are guarded and marked with appropriate warning labels. In addition a prominent label shall be provided on each unit giving adequate instructions for the removal of all such power from the unit.

Compliance is checked by inspection.

3.4.11 Multiple power sources

Where a unit receives power from more than one source (for example, different voltages or frequencies or as backup power), there shall be a prominent marking at each disconnect device giving adequate instructions for the removal of all power from the unit.

Compliance is checked by inspection.

3.5 Interconnection of equipment

3.5.1 General requirements

Where an equipment is intended to be electrically connected to another equipment, to an accessory or to a TELECOMMUNICATION NETWORK, interconnection circuits shall be selected to provide continued conformance to the requirements of 2.2 for SELV CIRCUITS, and with the requirements of 2.3 for TNV CIRCUITS, after making connections.

NOTE 1 This is normally achieved by connecting SELV CIRCUITS to SELV CIRCUITS, and TNV CIRCUITS to TNV CIRCUITS.

NOTE 2 It is permitted for an INTERCONNECTING CABLE to contain more than one type of circuit (for example, SELV CIRCUIT, LIMITED CURRENT CIRCUIT, TNV CIRCUIT, ELV CIRCUIT or HAZARDOUS VOLTAGE circuit) provided that they are separated as required by this standard.

Compliance is checked by inspection.

3.5.2 Types of interconnection circuits

Each interconnection circuit shall be one of the following types:

- an SELV CIRCUIT or a LIMITED CURRENT CIRCUIT; or
- a TNV-1, TNV-2 or TNV-3 CIRCUIT; or
- a HAZARDOUS VOLTAGE circuit.

Except as permitted in 3.5.3, interconnection circuits shall not be ELV CIRCUITS.

Compliance is checked by inspection.

3.5.3 ELV circuits as interconnection circuits

Where additional equipment is specifically complementary to the host (first) equipment (for example, a collator for a copying machine) ELV CIRCUITS are permitted as interconnection circuits between the equipments, provided that the equipments continue to meet the requirements of this standard when connected together.

Compliance is checked by inspection.

4 Physical requirements

4.1 Stability

Under conditions of normal use, units and equipment shall not become physically unstable to the degree that they could become a hazard to an OPERATOR or to a SERVICE PERSON.

If units are designed to be fixed together on site and not used individually, the stability of each individual unit is exempt from the requirements of 4.1.

The requirements of 4.1 are not applicable if the installation instructions for a unit specify that the equipment is to be secured to the building structure before operation.

Under conditions of OPERATOR use, a stabilizing means, if needed, shall be automatic in operation when drawers, doors, etc., are opened.

During operations performed by a SERVICE PERSON, the stabilizing means, if needed, shall either be automatic in operation, or a marking shall be provided to instruct the SERVICE PERSON to deploy the stabilizing means.

Compliance is checked by the following tests, where relevant. Each test is carried out separately. During the tests, containers are to contain the amount of substance within their rated capacity producing the most disadvantageous condition. All castors and jacks, if used in normal operation, are placed in their most unfavourable position, with wheels and the like locked or blocked. However, if the castors are intended only to transport the unit, and if the installation instructions require jacks to be lowered after installation, then the jacks (and not the castors) are used in this test; the jacks are placed in their most unfavourable position, consistent with reasonable levelling of the unit.

- *A unit shall not fall over when tilted to an angle of 10° from its normal upright position. Doors, drawers, etc., are closed during this test.*
- *A floor-standing unit having a mass of 25 kg or more shall not fall over when a force equal to 20 % of the weight of the unit, but not more than 250 N, is applied in any direction except upwards, at a height not exceeding 2 m from the floor. Doors, drawers, etc., which may be moved for servicing by the OPERATOR or by a SERVICE PERSON, are placed in their most unfavourable position, consistent with the installation instructions.*
- *A floor-standing unit shall not fall over when a constant downward force of 800 N is applied at the point of maximum moment to any horizontal surface of at least 12,5 cm by at least 20 cm, at a height up to 1 m from the floor. Doors, drawers, etc., are closed during this test. The 800 N force is applied by means of a suitable test tool having a flat surface of approximately 12,5 cm by 20 cm. The downward force is applied with the complete flat surface of the test tool in contact with the EUT; the test tool need not be in full contact with uneven surfaces (for example, corrugated or curved surfaces).*

4.2 Mechanical strength

4.2.1 General

Equipment shall have adequate mechanical strength and shall be so constructed as to remain safe in the meaning of this standard when subjected to handling as may be expected.

Mechanical strength tests are not required on an internal barrier, screen or the like, provided to meet the requirements of 4.6.2, if the ENCLOSURE provides mechanical protection.

A MECHANICAL ENCLOSURE shall be sufficiently complete to contain or deflect parts which, because of failure or for other reasons, might become loose, separated or thrown from a moving part.

Compliance is checked by inspection of the construction and available data and, where necessary, by the relevant tests of 4.2.2 to 4.2.7 as specified.

The tests are not applied to handles, levers, knobs, the face of cathode ray tubes (see 4.2.8) or to transparent or translucent covers of indicating or measuring devices, unless parts at HAZARDOUS VOLTAGE are accessible by means of the test finger, figure 2A (see 2.1.1.1), if the handle, lever, knob or cover is removed.

During the tests of 4.2.2, 4.2.3 and 4.2.4, earthed or unearthed conductive ENCLOSURES shall not bridge parts between which a HAZARDOUS ENERGY LEVEL exists and shall not contact a bare part at HAZARDOUS VOLTAGE. For voltages exceeding 1 000 V a.c. or 1 500 V d.c., contact is not permitted and there shall be an air gap between the part at HAZARDOUS VOLTAGE and the ENCLOSURE. This air gap shall either have a minimum length equal to the minimum CLEARANCE specified in 2.10.3 for BASIC INSULATION or withstand the relevant electric strength test in 5.2.2.

After the tests of 4.2.2 to 4.2.7, the sample shall continue to comply with the requirements of 2.1.1, 2.6.1, 2.10, 3.2.6 and 4.4.1. It shall show no signs of interference with the operation of safety features such as THERMAL CUT-OUTS, overcurrent protection devices or interlocks. In case of doubt, SUPPLEMENTARY INSULATION or REINFORCED INSULATION is subjected to an electric strength test as specified in 5.2.2.

Damage to finish, cracks, dents and chips are disregarded if they do not adversely affect safety.

NOTE If a separate ENCLOSURE or part of an ENCLOSURE is used for a test, it may be necessary to reassemble such parts on the equipment in order to check compliance.

4.2.2 Steady force test, 10 N

Components and parts, other than parts serving as an ENCLOSURE (see 4.2.3 and 4.2.4), are subjected to a steady force of 10 N ± 1 N.

Compliance criteria are in 4.2.1.

4.2.3 Steady force test, 30 N

Parts of an ENCLOSURE located in an OPERATOR ACCESS AREA, which are protected by a cover or door meeting the requirements of 4.2.4, are subjected to a steady force of 30 N ± 3 N for a period of 5 s, applied by means of a straight unjointed version of the test finger, figure 2A (see 2.1.1.1), to the part on or within the equipment.

Compliance criteria are in 4.2.1.

4.2.4 Steady force test, 250 N

External ENCLOSURES are subjected to a steady force of $250\text{ N} \pm 10\text{ N}$ for a period of 5 s, applied in turn to the top, bottom and sides of the ENCLOSURE fitted to the equipment, by means of a suitable test tool providing contact over a circular plane surface 30 mm in diameter. However, this test is not applied to the bottom of an ENCLOSURE of equipment having a mass of more than 18 kg.

Compliance criteria are in 4.2.1.

4.2.5 Impact test

Except for equipment identified in 4.2.6, external surfaces of ENCLOSURES, the failure of which would give access to hazardous parts, are tested as follows.

A sample consisting of the complete ENCLOSURE, or a portion thereof representing the largest unreinforced area, is supported in its normal position. A solid smooth steel ball, approximately 50 mm in diameter and with a mass of $500\text{ g} \pm 25\text{ g}$, is permitted to fall freely from rest through a vertical distance (H) of 1,3 m (see figure 4A) onto the sample. (Vertical surfaces are exempt from this test.)

In addition, the steel ball is suspended by a cord and swung as a pendulum in order to apply a horizontal impact, dropping through a vertical distance (H) of 1,3 m (see figure 4A) onto the sample. (Horizontal surfaces are exempt from this test.) Alternatively, the sample is rotated 90° about each of its horizontal axes and the ball dropped as in the vertical impact test.

The test is not applied to flat panel displays or to the platen glass of equipment (for example, copying machines).

Compliance criteria are in 4.2.1.

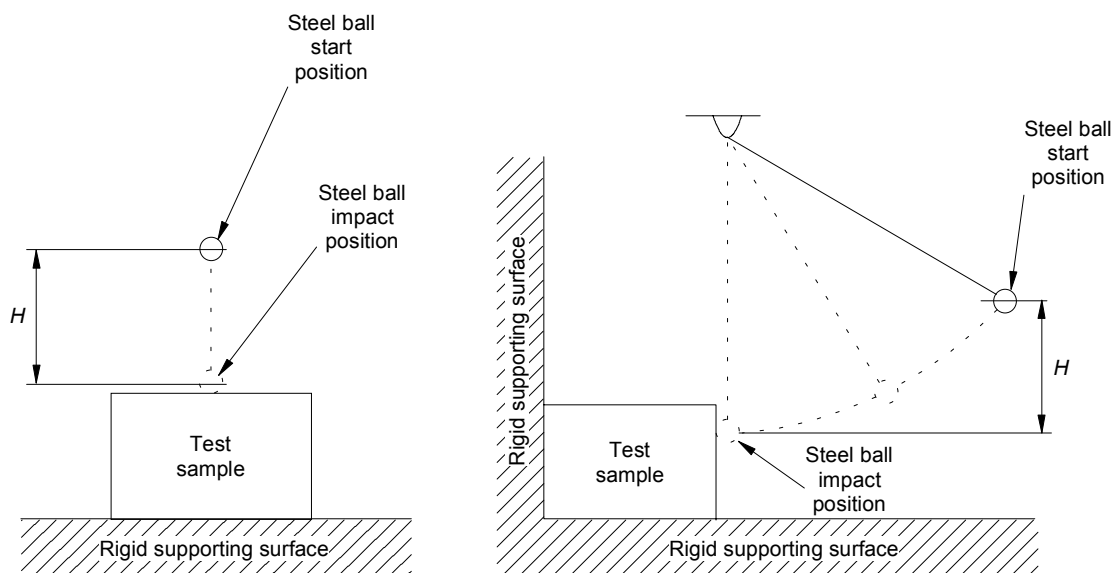

IEC 440/99

Figure 4A – Impact test using a steel ball

4.2.6 Drop test

The following equipment is subjected to a drop test:

- HAND-HELD EQUIPMENT;
- DIRECT PLUG-IN EQUIPMENT;
- TRANSPORTABLE EQUIPMENT;
- desk-top equipment having a mass of 5 kg or less that is intended for use with any one of the following:
 - a cord-connected telephone handset, or
 - another cord-connected hand-held accessory with an acoustic function, or
 - a headset.

A sample of the complete equipment is subjected to three impacts that result from being dropped onto a horizontal surface in positions likely to produce the most adverse results.

The height of the drop shall be:

- 750 mm ± 10 mm for desk-top equipment as described above;
- 1 000 mm ± 10 mm for HAND-HELD EQUIPMENT, DIRECT PLUG-IN EQUIPMENT and TRANSPORTABLE EQUIPMENT.

The horizontal surface consists of hardwood at least 13 mm thick, mounted on two layers of plywood each 19 mm to 20 mm thick, all supported on a concrete or equivalent non-resilient floor.

Compliance criteria are in 4.2.1.

4.2.7 Stress relief test

ENCLOSURES of moulded or formed thermoplastic materials shall be so constructed that any shrinkage or distortion of the material due to release of internal stresses caused by the moulding or forming operation does not result in the exposure of hazardous parts or in the reduction of CREEPAGE DISTANCES or CLEARANCES below the minimum required.

Compliance is checked by the test procedure described below or by the inspection of the construction and the available data where appropriate.

One sample consisting of the complete equipment, or of the complete ENCLOSURE together with any supporting framework, is placed in a circulating air oven (according to IEC 60216-4-1) at a temperature 10 K higher than the maximum temperature observed on the ENCLOSURE during the test of 4.5.1, but not less than 70 °C, for a period of 7 h, then permitted to cool to room temperature.

With the concurrence of the manufacturer, it is permitted to increase the above time duration.

For large equipment where it is impractical to condition a complete ENCLOSURE, it is permitted to use a portion of the ENCLOSURE representative of the complete assembly with regard to thickness and shape, including any mechanical support members.

NOTE Relative humidity need not be maintained at a specific value during this test.

If the above test is conducted, the compliance criteria of 4.2.1 apply.

4.2.8 Cathode ray tubes

If a cathode ray tube having a maximum face dimension exceeding 160 mm is included in the equipment, the cathode ray tube or the equipment, or both, shall comply with the requirements of IEC 60065 for mechanical strength and protection against the effects of implosion.

As an alternative, a cathode ray tube complying with IEC 61965 is permitted.

Compliance is checked by inspection, by measurement and, if necessary, by the relevant tests of IEC 60065.

4.2.9 High pressure lamps

The MECHANICAL ENCLOSURE of a high pressure lamp shall have adequate strength to contain an explosion of the lamp so as to reduce the likelihood of harm to an OPERATOR or person near the equipment during normal use or OPERATOR servicing.

For the purpose of this standard, a "high pressure lamp" means one in which the pressure exceeds 0,2 MPa when cold or 0,4 MPa when operating.

Compliance is checked by inspection.

4.2.10 Wall or ceiling mounted equipment

The mounting means of equipment intended for wall or ceiling mounting shall be adequate.

Compliance is checked by inspection of the construction and of available data, or where necessary, by the following test.

The equipment is mounted in accordance with the manufacturer's instructions. A force in addition to the weight of the equipment is applied downwards through the geometric centre of the equipment, for 1 min. The additional force shall be equal to three times the weight of the equipment but not less than 50 N. The equipment and its associated mounting means shall remain secure during the test.

4.3 Design and construction

4.3.1 Edges and corners

Where edges or corners could be hazardous to OPERATORS because of location or application in the equipment, they shall be rounded or smoothed.

This requirement does not apply to edges or corners that are required for proper functioning of the equipment.

Compliance is checked by inspection.

4.3.2 Handles and manual controls

Handles, knobs, grips, levers and the like shall be reliably fixed so that they will not work loose in normal use, if this might result in a hazard. Sealing compounds and the like, other than self-hardening resins, shall not be used to prevent loosening.

If handles, knobs and the like are used to indicate the position of switches or similar components, it shall not be possible to fix them in a wrong position if this might result in a hazard.

Compliance is checked by inspection, by manual test and by trying to remove the handle, knob, grip or lever by applying for 1 min an axial force as follows.

If the shape of these parts is such that an axial pull is unlikely to be applied in normal use, the force is:

- 15 N for the operating means of electrical components; and
- 20 N in other cases.

If the shape is such that an axial pull is likely to be applied, the force is:

- 30 N for the operating means of electrical components; and
- 50 N in other cases.

4.3.3 Adjustable controls

Equipment shall be so constructed that manual adjustment of a control device, such as a device for selection of different AC MAINS SUPPLY voltages, requires the use of a TOOL if incorrect setting or inadvertent adjustment might create a hazard.

NOTE Marking requirements for supply voltage adjustment are in 1.7.4.

Compliance is checked by manual test.

4.3.4 Securing of parts

Screws, nuts, washers, springs or similar parts shall be secured so as to withstand mechanical stresses occurring in normal use if loosening would create a hazard, or if CLEARANCES or CREEPAGE DISTANCES over SUPPLEMENTARY INSULATION or REINFORCED INSULATION would be reduced to less than the values specified in 2.10.

NOTE 1 Requirements regarding fixing of conductors are in 3.1.9.

Compliance is checked by inspection, by measurement and by manual test.

For the purpose of assessing compliance:

- it is assumed that two independent fixings will not become loose at the same time; and
- it is assumed that parts fixed by means of screws or nuts provided with self-locking washers or other means of locking are not liable to become loose.

NOTE 2 Spring washers and the like can provide satisfactory locking.

4.3.5 Connection of plugs and sockets

Within a manufacturer's unit or system, plugs and sockets likely to be used by the OPERATOR or by a SERVICE PERSON shall not be employed in a manner likely to create a hazard due to misconnection. In particular, connectors complying with IEC 60083 or IEC 60320 shall not be used for SELV CIRCUITS or TNV CIRCUITS. Keying, location or, in the case of connectors accessible only to a SERVICE PERSON, clear markings are permitted to meet the requirement.

Compliance is checked by inspection.

4.3.6 Direct plug-in equipment

DIRECT PLUG-IN EQUIPMENT shall not impose undue stress on the socket-outlet. The mains plug part shall comply with the standard for the relevant mains plug.

Compliance is checked by inspection and, if necessary, by the following test.

The equipment is inserted, as in normal use, into a fixed socket-outlet of a configuration as intended by the manufacturer, which can be pivoted about a horizontal axis intersecting the centre lines of the contacts at a distance of 8 mm behind the engagement face of the socket-outlet. The additional torque which has to be applied to the socket-outlet to maintain the engagement face in the vertical plane shall not exceed 0,25 N · m.

NOTE 1 In Australia, compliance is checked in accordance with AS/NZS 3112.

NOTE 2 In the United Kingdom:

- the torque test is performed using a socket-outlet complying with BS 1363, with an earthing contact;
- the plug part of DIRECT PLUG-IN EQUIPMENT is assessed to BS 1363: Part 1, 12.1, 12.2, 12.3, 12.9, 12.11, 12.12, 12.16 and 12.17, except that the test in 12.17 is carried out at not less than 125 °C.

4.3.7 Heating elements in earthed equipment

Heating elements in equipment that is earthed for safety purposes shall be protected so that, under earth fault conditions, a fire hazard due to overheating is prevented. In such equipment, temperature sensing devices, if provided, shall be located in all line conductors supplying the heating elements.

The temperature sensing devices shall also disconnect the neutral conductor for each of the following cases.

- a) In equipment supplied from an IT power distribution system.
- b) In PLUGGABLE EQUIPMENT supplied through a reversible appliance coupler or a reversible plug.
- c) In equipment supplied from a socket-outlet with indeterminate polarity.

In cases b) and c), it is permitted to meet this requirement by connecting a THERMOSTAT in one conductor and a THERMAL CUT-OUT in the other conductor.

It is not required to disconnect the conductors simultaneously.

Compliance is checked by inspection.

4.3.8 Batteries

NOTE 1 Requirements for markings or instructions are given in 1.7.15.

Equipment containing batteries shall be designed to reduce the risk of fire, explosion and chemical leaks under normal conditions and after a single fault in the equipment (see 1.4.14), including a fault in circuitry within the equipment battery pack. For USER-replaceable batteries, the design shall reduce the likelihood of reverse polarity installation if this would create a hazard.

Battery circuits shall be designed so that:

- the output characteristics of a battery charging circuit are compatible with its rechargeable battery; and
- for non-rechargeable batteries, discharging at a rate exceeding the battery manufacturer's recommendations, and unintentional charging, are prevented; and

- for rechargeable batteries, charging and discharging at a rate exceeding the battery manufacturer's recommendations, and reversed charging, are prevented.

NOTE 2 Reversed charging of a rechargeable battery occurs when the polarity of the charging circuit is reversed, aiding the discharge of the battery.

Compliance is checked by inspection and by evaluation of the data provided by the equipment manufacturer and battery manufacturer for charging and discharging rates.

When appropriate data is not available, compliance is checked by test. However, batteries that are inherently safe for the conditions given are not tested under those conditions. Consumer grade, non-rechargeable carbon-zinc or alkaline batteries are considered safe under short-circuiting conditions and therefore are not tested for discharge; nor are such batteries tested for leakage under storage conditions.

A new non-rechargeable battery or fully charged rechargeable battery provided with, or recommended by the manufacturer for use with, the equipment shall be used for each of the following tests:

- *for evaluating the overcharging of a rechargeable battery, a battery is charged for a period of 7 h under each of the following conditions in turn:*
 - *with the battery charging circuit adjusted for its maximum charging rate (if such an adjustment exists); followed by*
 - *any single component failure that is likely to occur in the charging circuit and which would result in overcharging of the battery; and*
- *for evaluating the unintentional charging of a non-rechargeable battery, a battery is charged for 7 h with any single component failure that is likely to occur and which would result in unintentional charging of the battery; and*
- *for evaluating the reversed charging of a rechargeable battery, a battery is charged for 7 h with any single component failure that is likely to occur and which would result in reversed charging of the battery; and*
- *for evaluating an excessive discharging rate for any battery, a battery is subjected to rapid discharge by open-circuiting or short-circuiting any current-limiting or voltage-limiting components in the load circuit of the battery under test.*

NOTE 3 Some of the tests specified can be hazardous to the persons carrying them out; all appropriate measures to protect personnel against possible chemical or explosion hazards should be taken.

These tests shall not result in any of the following:

- *chemical leaks caused by cracking, rupturing or bursting of the battery jacket, if such leakage could adversely affect required insulation; or*
- *explosion of the battery, if such explosion could result in injury to a USER; or*
- *emission of flame or expulsion of molten metal to the outside of the equipment ENCLOSURE.*

After completion of the tests, the equipment is subjected to the electric strength tests of 5.3.8.2.

4.3.9 Oil and grease

Where internal wiring, windings, commutators, slip-rings and the like, and insulation in general, are exposed to oil, grease or similar substances, the insulation shall have adequate properties to resist deterioration under these conditions.

Compliance is checked by inspection, and by evaluation of the data for the insulating material.

4.3.10 Dust, powders, liquids and gases

Equipment producing dust (for example, paper dust) or using powders, liquids or gases shall be so constructed that no dangerous concentration of these materials can exist and that no hazard in the meaning of this standard is created by condensation, vaporization, leakage, spillage or corrosion during normal operation, storage, filling or emptying. In particular, CREEPAGE DISTANCES and CLEARANCES shall not be reduced below the requirements of 2.10.

Compliance is checked by inspection, measurement and, where spillage of liquid could affect electrical insulation during replenishment, by the following test and, for flammable liquids, by the tests of 4.3.12.

The equipment shall be ready to use according to its installation instructions, but not energized.

The liquid container of the equipment is completely filled with the liquid specified by the manufacturer and a further quantity, equal to 15 % of the capacity of the container is poured in steadily over a period of 1 min. For liquid containers having a capacity not exceeding 250 ml, and for containers without drainage and for which the filling cannot be observed from outside, a further quantity of liquid, equal to the capacity of the container, is poured in steadily over a period of 1 min.

Immediately after this treatment, the equipment shall withstand an electric strength test as specified in 5.2.2 on any insulation on which spillage could have occurred and inspection shall show that the liquid has not created a hazard in the meaning of this standard.

The equipment is permitted to stand in normal test-room atmosphere for 24 h before being subjected to any further electrical test.

4.3.11 Containers for liquids or gases

Equipment that, in normal use, contains liquids or gases shall incorporate adequate safeguards against build-up of excessive pressure.

Compliance is checked by inspection and, if necessary, by an appropriate test.

4.3.12 Flammable liquids

If a flammable liquid is used in equipment, the liquid shall be kept in a closed reservoir, except for the amount needed for the functioning of the equipment. The maximum quantity of flammable liquid stored in an equipment shall in general be not more than 5 l. If, however, the usage of liquid is such that more than 5 l is consumed in 8 h, the quantity stored is permitted to be increased to that required for an 8 h operation.

Oil or equivalent liquids used for lubrication or in a hydraulic system shall have a flash point of 149 °C or higher, and the reservoir shall be of sealed construction. The system shall have provision for expansion of the liquid and shall incorporate means for pressure relief. This requirement is not applicable to lubricating oils which are applied to points of friction in quantities which would contribute negligible fuel to a fire.

Except under conditions given below, replenishable liquids such as printing inks shall have a flash point of 60 °C or higher, and shall not be under sufficient pressure to cause atomization.

Replenishable flammable liquids which have a flash point of less than 60 °C or which are under sufficient pressure to cause atomization are permitted provided inspection shows that there is no likelihood of liquid sprays or build-up of flammable vapour-air mixtures which could cause explosion or fire hazard. Under normal operating conditions, equipment using a flammable liquid shall not generate a mixture with a concentration exceeding one quarter of the EXPLOSION LIMIT if the mixture is in proximity to an ignition source, or exceeding half the EXPLOSION LIMIT if the mixture is not in proximity to an ignition source. The investigation shall also take into account the integrity of the liquid handling system. The liquid handling system shall be suitably housed or constructed so as to avoid the risk of fire or explosion, even under the test conditions specified in 4.2.5.

Compliance is checked by inspection and, where necessary, by the following test.

The equipment is operated in accordance with 4.5.1 until its temperature stabilizes. In this condition, the equipment is operated in a normal manner, as directed in the operating instructions, and samples of the atmosphere in the vicinity of the electrical components and around the equipment are taken to determine the concentration of flammable vapours present.

Samples of the atmosphere are taken at 4 min intervals; four samples to be taken during normal operation, then seven samples after the equipment has stopped.

If, after the equipment has stopped, the concentration of flammable vapours appears to be increasing, samples shall continue to be taken at 4 min intervals until the concentration is shown to be decreasing.

If an abnormal operation of the equipment is possible with any of its fans not running, this condition is simulated during this compliance test.

4.3.13 Radiation

4.3.13.1 General

Equipment shall be so designed that the risk of harmful effects of radiation to persons, and damage to materials affecting safety, is reduced.

Compliance is checked by inspection and as detailed in 4.3.13.2, 4.3.13.3, 4.3.13.4, 4.3.13.5 and 4.3.13.6 as appropriate.

4.3.13.2 Ionizing radiation

For equipment which generates ionizing radiation, compliance is checked by the test in annex H.

4.3.13.3 Effect of ultraviolet (UV) radiation on materials

The following requirements apply only to equipment containing lamps which produce significant UV radiation, that is having emission predominantly in the spectrum 180 nm to 400 nm, as specified by the lamp manufacturer.

NOTE General-purpose incandescent and fluorescent lamps, with ordinary glass envelopes, are not considered to emit significant UV radiation.

Non-metallic parts (for example, non-metallic ENCLOSURES and internal materials including wire and cable insulation) that are exposed to UV radiation from a lamp in the equipment, shall be sufficiently resistant to degradation to the extent that safety is not affected.

Table 4A – Minimum property retention limits after UV exposure

Parts to be tested	Property	Standard for the test method	Minimum retention after test
Parts providing mechanical support	Tensile strength ¹⁾ or Flexural strength ^{1) 2)}	ISO 527	70 %
		ISO 178	70 %
Parts providing impact resistance	Charpy impact ³⁾ or Izod impact ³⁾ or Tensile impact ³⁾	ISO 179	70 %
		ISO 180	70 %
		ISO 8256	70 %
All parts	Flammability classification	See 1.2.12 and annex A	See ⁴⁾

¹⁾ Tensile strength and Flexural strength tests are to be conducted on specimens no thicker than the actual thicknesses.
²⁾ The side of the sample exposed to UV radiation is to be in contact with the two loading points when using the three point loading method.
³⁾ Tests conducted on 3,0 mm thick specimens for Izod impact and Tensile impact tests and 4,0 mm thick specimens for Charpy impact tests are considered representative of other thicknesses, down to 0,8 mm.
⁴⁾ The flammability classification may change as long as it does not fall below that specified in clause 4.

Compliance is checked by examination of the construction and of available data regarding the UV resistance characteristics of the parts exposed to UV radiation in the equipment. If such data is not available, the tests in table 4A are carried out on the parts.

Samples taken from the parts, or consisting of identical material, are prepared according to the standard for the test to be carried out. They are then conditioned according to annex Y. After conditioning, the samples shall show no signs of significant deterioration, such as crazing or cracking. They are then kept at room ambient conditions for not less than 16 h and not more than 96 h, after which they are tested according to the standard for the relevant test.

In order to evaluate the percent retention of properties after test, samples that have not been conditioned according to annex Y are tested at the same time as the conditioned samples. The retention shall be as specified in table 4A.

4.3.13.4 Human exposure to ultraviolet (UV) radiation

The following requirements apply only to equipment containing lamps which produce significant UV radiation, that is having emission predominantly in the spectrum 180 nm to 400 nm as specified by the lamp manufacturer.

NOTE 1 General purpose incandescent and fluorescent lamps, with ordinary glass envelopes, are not considered to emit significant UV radiation.

Equipment shall not emit excessive UV radiation.

UV radiation shall either:

- be adequately contained by the ENCLOSURE of the UV lamp or the ENCLOSURE of the equipment; or
- not exceed the relevant limits given in IEC 60825-9.

During normal operation, the relevant limit is that for 8 h exposure.

Higher limits are permitted for limited periods of time for maintenance and cleaning operations, if it is necessary for the UV lamp to be on during these operations. The relevant limits are those for the expected time intervals for these operations, which shall be stated in the USER and servicing instructions.

All USER access doors and covers that, if opened, would allow access to higher emissions than those permitted above shall be marked with one of the following (see also 1.7.14):

- "WARNING: TURN OFF THE UV LAMP BEFORE OPENING", or equivalent; or
- the symbol  or equivalent.

The above marking is not required for a door or cover that is provided with a SAFETY INTERLOCK switch (see 2.8) that disconnects power to the UV lamp when the door or cover is opened, or any other mechanism which prevents UV radiation.

If the UV radiation symbol is used on the equipment, both the symbol and a warning similar to the above marking shall appear together in the USER and servicing instructions.

If higher emissions than those permitted above are accessible in a SERVICE ACCESS AREA, and it is necessary for the equipment to remain energized while being serviced, the equipment shall be marked with one of the following:

- "WARNING: USE UV RADIATION EYE AND SKIN PROTECTION DURING SERVICING", or equivalent; or
- the symbol  or equivalent.

The marking shall be located where readily visible during the servicing operation (see also 1.7.14).

If the UV radiation symbol is used on the equipment, both the symbol and a warning similar to the above marking shall appear together in the servicing instructions.

Compliance is checked by inspection, and if necessary by measurement.

UV radiation is measured using a scanning spectrograph or a specific detector having a spectral response equal to the relative spectral effectiveness for the UV range.

The UV radiation exposure and effective irradiance during normal operation shall not exceed the limits given in IEC 60825-9 for an 8 h exposure.

The UV radiation exposure and effective irradiance during maintenance and cleaning operations shall not exceed the limits in IEC 60825-9 corresponding to the exposure times stated for these operations in the relevant instructions. The maximum permitted radiation is that for 30 min exposure.

NOTE 2 The permitted radiation is increased as the exposure time is reduced.

All USER access doors and covers, and parts such as lenses, filters and the like, if their opening or removal could result in an increase in the UV radiation, shall be opened or removed during measurements, unless provided with a SAFETY INTERLOCK switch that disconnects the power to the UV lamp, or any other mechanism which prevents UV radiation.

NOTE 3 For guidance on measuring techniques, see CIE Publication 63.

4.3.13.5 Lasers (including LEDs)

Except as permitted below, equipment shall be classified and labelled according to IEC 60825-1 and IEC 60825-2, as applicable.

Equipment which is inherently a Class I laser product, that is the equipment contains no laser or light emitting diode (LED) of a higher class number, is not required to have a laser warning label or other laser statement (see 1.1 of IEC 60825-1).

The data for laser or LED components shall confirm that these components comply with the Accessibility Emission Limit for Class I when measured according to IEC 60825-1, for the above exception to apply. The data may be obtained from the component manufacturer (see 1.4.15) and can relate to the component alone or to the component in its intended application in the equipment. The lasers or LEDs shall produce radiation only in the wavelength range of 180 nm to 1 mm.

NOTE Some examples of applications of LEDs which will normally comply are those used as:

- indicating lights;
- infra-red devices such as are used in home entertainment devices;
- infra-red devices for data transmission such as are used between computers and computer peripherals;
- optocouplers; and
- other similar low power devices.

Compliance is checked by inspection, by evaluation of the data provided by the manufacturer and, if necessary, by testing according to IEC 60825-1.

4.3.13.6 Other types

For other types of radiation, compliance is checked by inspection.

4.4 Protection against hazardous moving parts

4.4.1 General

Hazardous moving parts of equipment, that is moving parts which have the potential to cause injury, shall be so arranged, enclosed or guarded as to provide adequate protection against the risk of personal injury.

AUTOMATIC RESET THERMAL CUT-OUTS or overcurrent protection devices, automatic timer starting, etc., shall not be incorporated if unexpected resetting might create a hazard.

Compliance is checked by inspection and as detailed in 4.4.2, 4.4.3 and 4.4.4.

4.4.2 Protection in operator access areas

In an OPERATOR ACCESS AREA, protection shall be provided by a suitable construction reducing the likelihood of access to hazardous moving parts, or by locating the moving parts in an ENCLOSURE provided with mechanical or electrical SAFETY INTERLOCKS that remove the hazard when access is gained.

Where it is not possible to comply fully with the above access requirements and also allow the equipment to function as intended, access is permitted provided that:

- the hazardous moving part concerned is directly involved in the process (for example, moving parts of a paper cutter); and
- the hazard associated with the part is obvious to the OPERATOR; and
- additional measures are taken as follows:
 - a statement shall be provided in the operating instructions and a marking shall be fixed to the equipment, each containing the following or a similar appropriate wording;

WARNING
HAZARDOUS MOVING PARTS
KEEP FINGERS AND OTHER BODY PARTS AWAY

- where the possibility exists that fingers, jewellery, clothing, etc., can be drawn into the moving parts, means shall be provided to enable the OPERATOR to stop the moving part.

The above warning notice and, where relevant, the means provided for stopping the moving part shall be placed in a prominent position, readily visible and accessible from the point where the risk of injury is greatest.

Compliance is checked by inspection and where necessary by a test with the test finger, figure 2A (see 2.1.1.1), after removal of OPERATOR-detachable parts, and with OPERATOR access doors and covers open.

Unless additional measures have been taken as specified above, it shall not be possible to touch hazardous moving parts with the test finger, applied without appreciable force in every possible position.

Openings preventing the entry of the test finger, figure 2A (see 2.1.1.1), are further tested by means of a straight unjointed version of the test finger applied with a force of 30 N. If the unjointed finger enters, the test with the test finger, figure 2A (see 2.1.1.1), is repeated, except that the finger is pushed through the opening using any necessary force up to 30 N.

4.4.3 Protection in restricted access locations

For equipment to be installed in a RESTRICTED ACCESS LOCATION, the requirements and compliance criteria in 4.4.2 for OPERATOR ACCESS AREAS apply.

4.4.4 Protection in service access areas

In a SERVICE ACCESS AREA, protection shall be provided such that unintentional contact with hazardous moving parts is unlikely during servicing operations involving other parts of the equipment.

Compliance is checked by inspection.

4.5 Thermal requirements

Subclause 4.5 specifies requirements intended to prevent:

- touchable parts from exceeding certain temperatures; and
- components, parts, insulation and plastic materials from exceeding temperatures which may degrade electrical, mechanical, or other properties during normal use over the expected life of the equipment.

Consideration shall be given to the fact that, on a long-term basis, the electrical and mechanical properties of certain insulating materials may be adversely affected (for example, by softeners evaporating at temperatures below the normal softening temperatures of the materials), see 2.9.1.

4.5.1 Maximum temperatures

Materials used in components and in the construction of the equipment shall be selected so that under NORMAL LOAD, temperatures do not exceed safe values in the meaning of this standard.

Components working at high temperature shall be effectively shielded or separated to avoid overheating of their adjacent materials and components.

Compliance is checked by inspection of material data sheets and by determining and recording the temperatures in accordance with 1.4.12 and 1.4.13.

Taking into account the requirements of 1.4.5, the equipment or parts of the equipment are operated under NORMAL LOAD as follows:

- *for CONTINUOUS OPERATION, until steady conditions are established; and*
- *for INTERMITTENT OPERATION, until steady conditions are established, using the rated "ON" and "OFF" periods; and*
- *for SHORT-TIME OPERATION, for the RATED OPERATING TIME.*

It is permitted to test components and other parts independently provided that the test conditions applicable to the equipment are followed.

Equipment intended for building-in or rack-mounting, or for incorporation in larger equipment, is tested under the most adverse actual or simulated conditions permitted in the installation instructions.

The temperature of electrical insulation (other than that of windings, see 1.4.13), the failure of which could create a hazard, is measured on the surface of the insulation at a point close to the heat source, see item 1) of table 4B. During the test:

- THERMAL CUT-OUTS and overcurrent protection devices shall not operate;
- THERMOSTATS are permitted to operate, provided that they do not interrupt the normal operation of the equipment;
- TEMPERATURE LIMITERS are permitted to operate;
- sealing compounds, if any, shall not flow out.

The temperature shall not exceed the values shown in table 4B, parts 1 and 2.

**Table 4B – Temperature limits
Part 1**

Part	Maximum temperature (T_{max}) °C
Insulation, including winding insulation: <ul style="list-style-type: none"> – of Class A material – of Class E material – of Class B material – of Class F material – of Class H material 	100 ^{1), 2), 3)} 115 ^{1), 2), 3)} 120 ^{1), 2), 3)} 140 ^{1), 2), 3)} 165 ^{1), 2), 3)}
Synthetic rubber or PVC insulation of internal and external wiring, including power supply cords: <ul style="list-style-type: none"> – without temperature marking – with temperature marking 	75 Temperature marking minus 25
Other thermoplastic insulation	4)
Terminals, including earthing terminals for external earthing conductors of STATIONARY EQUIPMENT, unless provided with a NON-DETACHABLE POWER SUPPLY CORD	85
Parts in contact with a flammable liquid	See 4.3.12
Components	See 1.5.1

**Temperature limits
Part 2**

Parts in OPERATOR ACCESS AREAS	Maximum temperature (T_{max})		
	°C		
	Metal	Glass, porcelain and vitreous material	Plastic and rubber ³⁾
Handles, knobs, grips, etc., held or touched for short periods only	60	70	85
Handles, knobs, grips, etc., continuously held in normal use	55	65	75
External surfaces of equipment which may be touched ⁵⁾	70	80	95
Parts inside the equipment which may be touched ⁶⁾	70	80	95

Table 4B (part 1 and part 2)

<p>1) If the temperature of a winding is determined by thermocouples, these values are reduced by 10 °C, except in the case of</p> <ul style="list-style-type: none"> – a motor, or – a winding with embedded thermocouples. <p>2) The classification of insulating materials (Classes A, E, B, F and H) is in accordance with IEC 60085.</p> <p>3) For each material, account shall be taken of the data for that material to determine the appropriate maximum temperature.</p> <p>4) Due to their wide variety, it is not possible to specify maximum permitted temperatures for thermoplastic materials. These shall pass the tests specified in 4.5.2.</p> <p>5) For areas on the external surface of equipment and having no dimension exceeding 50 mm, and which are not likely to be touched in normal use, temperatures up to 100 °C are permitted.</p> <p>6) Temperatures exceeding the limits are permitted provided that the following conditions are met:</p> <ul style="list-style-type: none"> – unintentional contact with such a part is unlikely; – the part has a marking indicating that this part is hot. It is permitted to use the symbol  (60417-1-IEC-5041) to provide this information.
--

For equipment intended for installation in a RESTRICTED ACCESS LOCATION, the temperature limits in table 4B, parts 1 and 2, apply, except that for external metal parts which are evidently designed as heat sinks or which have a visible warning, a temperature of 90 °C is permitted.

4.5.2 Resistance to abnormal heat

Thermoplastic parts on which parts at HAZARDOUS VOLTAGE are directly mounted shall be resistant to abnormal heat.

Compliance is checked by subjecting the part to the ball pressure test according to IEC 60695-10-2. The test is not made if it is clear from examination of the physical characteristics of the material that it will meet the requirements of this test.

The test is made in a heating cabinet at a temperature of $(T - T_{amb} + 40 \text{ °C}) \pm 2 \text{ °C}$ (see 1.4.12.1 for the significance of T and T_{amb}). However, a thermoplastic part supporting parts in a PRIMARY CIRCUIT is tested at a minimum of 125 °C.

4.6 Openings in enclosures

For equipment that is intended to be used in more than one orientation (see 1.3.6), the requirements of 4.6.1 and 4.6.2 apply in each appropriate orientation.

NOTE Additional requirements concerning openings in ENCLOSURES are in 2.1.1.

4.6.1 Top and side openings

Openings in the top and sides of ENCLOSURES, except for ENCLOSURES of TRANSPORTABLE EQUIPMENT (see 4.6.4), shall be so located or constructed that it is unlikely that objects will enter the openings and create hazards by contacting bare conductive parts.

NOTE 1 Hazards include energy hazards, and those created by bridging of insulation or by OPERATOR access to parts at HAZARDOUS VOLTAGE (for example, via metal jewellery).

Openings, located behind doors, panels, covers, etc., that can be opened or removed by an OPERATOR, are not required to comply provided that the equipment openings comply with the doors, panels and covers closed or in place.

Where a portion of the side of a FIRE ENCLOSURE falls within the area traced out by the 5° angle in figure 4E, the limitations in 4.6.2 on sizes of openings in bottoms of FIRE ENCLOSURES also apply to this portion of the side.

Compliance is checked by inspection and measurement. Except for that portion of the side of a FIRE ENCLOSURE that is subject to the requirements of 4.6.2 (see above paragraph), any one of the following is considered to satisfy the requirements (other constructions are not excluded):

- *openings that do not exceed 5 mm in any dimension;*
- *openings that do not exceed 1 mm in width regardless of length;*
- *top openings in which vertical entry is prevented (see figure 4B for examples);*
- *side openings provided with louvres that are shaped to deflect outwards an external vertically falling object (see figure 4C for examples);*
- *top or side openings, as shown in figure 4D, that are not located vertically, or within a volume V bounded by a 5° vertical projection up to the size of opening L, above bare conductive parts:*
 - *at HAZARDOUS VOLTAGE, or*
 - *which present an energy hazard within the meaning of 2.1.1.5.*

NOTE 2 The examples of figures 4B, 4C, 4D and 4E are not intended to be used as engineering drawings but are only shown to illustrate the intent of these requirements.

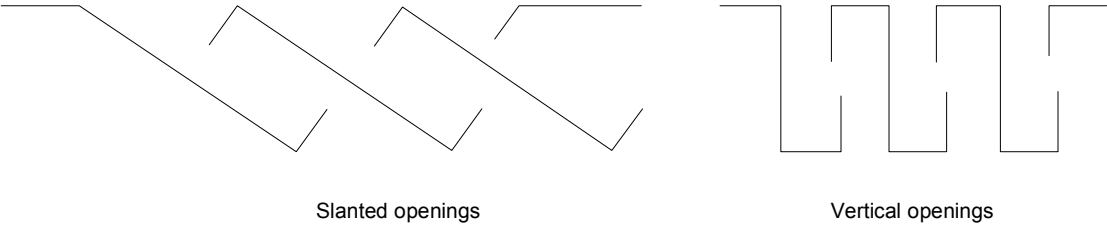

IEC 441/99

Figure 4B – Examples of cross-sections of designs of openings preventing vertical access

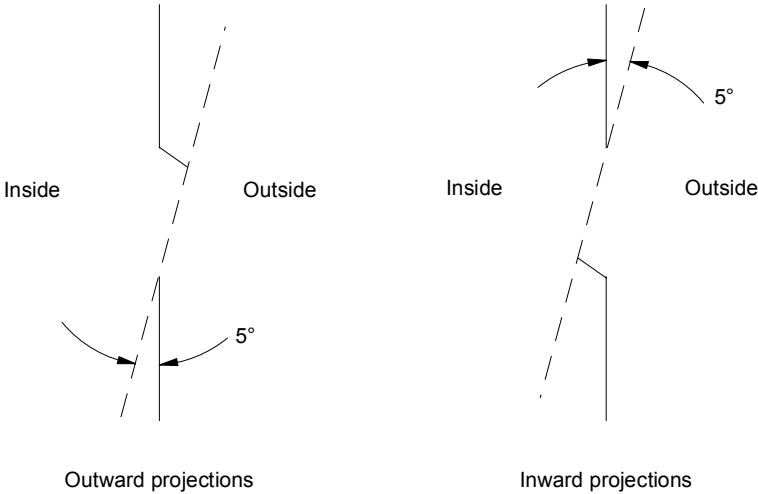

IEC 442/99

Figure 4C – Examples of louvre design

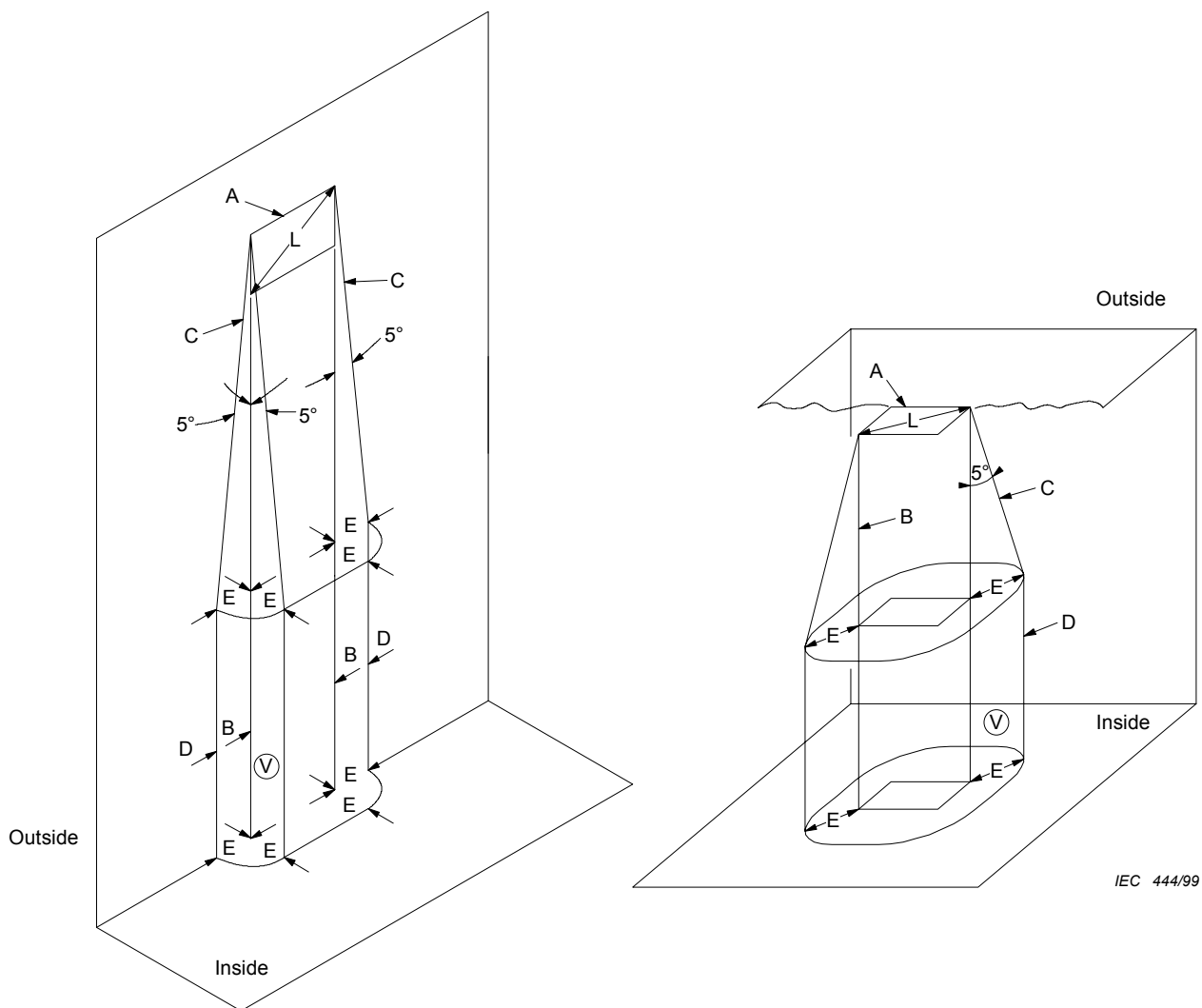

IEC 443/99

IEC 444/99

- A ENCLOSURE opening.
- B Vertical projection of the outer edges of the opening.
- C Inclined lines that project at a 5° angle from the edges of the opening to points located E distance from B.
- D Line which is projected straight downward in the same plane as the ENCLOSURE side wall.
- E Projection of the outer edge of the opening (B) and the inclined line (C) (not to be greater than L).
- L Maximum dimension of the ENCLOSURE opening.
- V Volume in which bare parts at HAZARDOUS VOLTAGE, or which are energy hazards (see 4.6.1), are not located.

Figure 4D – Enclosure openings

4.6.2 Bottoms of fire enclosures

The bottom of a FIRE ENCLOSURE, or individual barriers, shall provide protection under all internal parts, including partially enclosed components or assemblies, which, under fault conditions, could emit material likely to ignite the supporting surface.

NOTE See 4.7.2.2 for parts that do not require a FIRE ENCLOSURE.

The bottom or barrier shall be located as, and no smaller in area than, indicated in figure 4E and be horizontal, lipped or otherwise shaped to provide equivalent protection.

An opening in the bottom shall be protected by a baffle, screen or other means so that molten metal and burning material are unlikely to fall outside the FIRE ENCLOSURE.

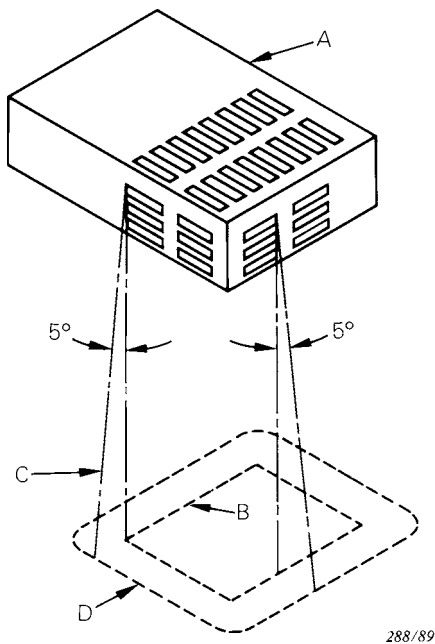

- A The portion of a component under which a FIRE ENCLOSURE is required, for example, under those openings in a component or assembly through which flaming particles might be emitted. If the component or assembly does not have its own FIRE ENCLOSURE, the area to be protected is the entire area occupied by the component or assembly.
- B The outline of the area of A projected vertically downward onto the horizontal plane of the lowest point of the FIRE ENCLOSURE.
- C Inclined line that traces an outline D on the same plane as B. Moving around the perimeter of the outline B, this line projects at a 5° angle from the vertical at every point round the perimeter of the openings in A and is oriented to trace out the largest area.
- D Minimum outline of the bottom of the FIRE ENCLOSURE. A portion of the side of a FIRE ENCLOSURE which is within the area traced out by the 5° angle is also considered to be part of the bottom of the FIRE ENCLOSURE.

Figure 4E – Typical bottom of a fire enclosure for partially enclosed component or assembly

The requirements of 4.6.2 do not apply to:

- TRANSPORTABLE EQUIPMENT, which is covered by 4.6.4; or
- STATIONARY EQUIPMENT intended only for use in a RESTRICTED ACCESS LOCATION and to be mounted on a concrete floor or other non-combustible surface. Such equipment shall be marked as follows:

**SUITABLE FOR MOUNTING ON CONCRETE
OR OTHER NON-COMBUSTIBLE SURFACE ONLY**

Compliance is checked by inspection and, where necessary, by the test of clause A.3.

The following constructions are considered to satisfy the requirement without test:

- no opening in the bottom of a FIRE ENCLOSURE;
- openings in the bottom of any size under an internal barrier, screen or the like, which itself complies with the requirements for a FIRE ENCLOSURE (see also 4.2.1);
- openings in the bottom, each not larger than 40 mm², under components and parts meeting the requirements for FLAMMABILITY CLASS V-1, or FLAMMABILITY CLASS HF-1 or under small components which pass the needle-flame test of IEC 60695-2-2 using a 30 s flame application;
- baffle plate construction as illustrated in figure 4F;
- metal bottoms of FIRE ENCLOSURES conforming to the dimensional limits of any line in table 4C;
- metal bottom screens having a mesh with nominal openings not greater than 2 mm between centre lines and with wire diameters of not less than 0,45 mm.

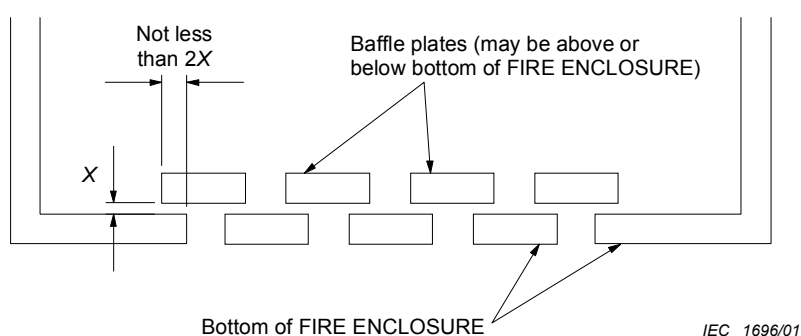

Figure 4F – Baffle plate construction

Table 4C – Size and spacing of openings in metal bottoms of fire enclosures

Applicable to circular holes			Applicable to other shaped openings	
Metal bottom minimum thickness	Maximum diameter of holes	Minimum spacing of holes centre to centre	Maximum area	Minimum spacing of openings border to border
mm	mm	mm	mm ²	mm
0,66	1,1	1,7	1,1	0,56
0,66	1,2	2,3	1,2	1,1
0,76	1,1	1,7	1,1	0,55
0,76	1,2	2,3	1,2	1,1
0,81	1,9	3,1	2,9	1,1
0,89	1,9	3,1	2,9	1,2
0,91	1,6	2,7	2,1	1,1
0,91	2,0	3,1	3,1	1,2
1,0	1,6	2,7	2,1	1,1
1,0	2,0	3,0	3,2	1,0

4.6.3 Doors or covers in fire enclosures

If part of a FIRE ENCLOSURE consists of a door or cover leading to an OPERATOR ACCESS AREA, it shall comply with one of the following requirements:

- the door or cover shall be interlocked to comply with the requirements in 2.8;
- a door or cover, intended to be routinely opened by the OPERATOR, shall comply with both of the following conditions:
 - it shall not be removable from other parts of the FIRE ENCLOSURE by the OPERATOR; and
 - it shall be provided with a means to keep it closed during normal operation;
- a door or cover intended only for occasional use by the OPERATOR, such as for the installation of accessories, is permitted to be removable provided that the equipment instructions include directions for correct removal and reinstallation of the door or cover.

Compliance is checked by inspection.

4.6.4 Openings in transportable equipment

The risk of ignition caused by small metallic objects, such as paper clips or staples, moving around inside TRANSPORTABLE EQUIPMENT during transportation shall be reduced by measures to minimize the likelihood of such objects entering the equipment and bridging bare conductive parts between which the power is not limited in accordance with 2.5.

Acceptable measures include:

- providing openings that do not exceed 1 mm in width regardless of length; or
- providing a screen having a mesh with nominal openings not greater than 2 mm between centre lines and constructed with a thread or wire diameter of not less than 0,45 mm; or
- providing internal barriers.

Additionally, where metallized parts of a plastic barrier or ENCLOSURE are within 13 mm of parts of circuits where the available power is greater than 15 VA, one of the following requirements applies:

- access by a foreign metallic object shall be limited in accordance with the above acceptable measures even though the available power meets the limits of 2.5; or
- there shall be a barrier between the bare conductive parts and the ENCLOSURE; or
- fault testing shall be carried out to simulate bridging along a direct path between a bare conductive part and the nearest metallized part of a barrier or ENCLOSURE that is within 13 mm of the bare conductive part.

NOTE Examples of metallized plastic barriers or ENCLOSURES include those made of conductive composite materials or that are electroplated, vacuum-deposited, painted or foil lined.

Compliance is checked by inspection and measurement and, where appropriate, by test. All doors or covers are closed or in place and peripheral devices or assemblies, such as disk drives, batteries, etc., are installed as intended during the inspection (see also 1.3.6).

If simulated fault testing is carried out, no ignition of the metallized barrier or ENCLOSURE shall occur.

4.6.5 Adhesives for constructional purposes

If a barrier or screen provided to comply with 4.6.1, 4.6.2 or 4.6.4 is secured with adhesive to the inside of the ENCLOSURE or to other parts inside the ENCLOSURE, the adhesive shall have adequate bonding properties throughout the life of the equipment.

Compliance is checked by examination of the construction and of the available data. If such data is not available, compliance is checked by the following tests.

A sample of the equipment or a part of the ENCLOSURE with the barrier or screen attached is evaluated with the sample placed with the barrier or screen on the underside.

Condition the sample in an oven at one of the following temperatures for the time durations specified:

100 °C ± 2 °C for one week; or

90 °C ± 2 °C for three weeks; or

82 °C ± 2 °C for eight weeks.

Upon completion of the temperature conditioning:

Remove the sample from oven and leave it at any convenient temperature between 20 °C and 30 °C for 1 h.

Place the sample in a freezer at –40 °C ± 2 °C for 4 h.

Remove and allow the sample to come to any convenient temperature between 20 °C and 30 °C for 8 h.

Place the sample in a cabinet at 91 % to 95 % relative humidity for 72 h.

Remove the sample and leave it at any convenient temperature between 20 °C and 30 °C for 1 h.

Place the sample in an oven at the temperature used for the temperature conditioning for 4 h.

Remove the sample and allow it to reach any convenient temperature between 20 °C and 30 °C for 8 h.

The sample is then immediately subjected to the tests of 4.2 as applicable. The barrier or screen shall not fall off or partly dislodge as a result of these tests.

With the concurrence of the manufacturer, it is permitted to increase any of the above time durations.

4.7 Resistance to fire

This subclause specifies requirements intended to reduce the risk of ignition and the spread of flame, both within the equipment and to the outside, by the appropriate use of materials and components and by suitable construction.

NOTE 1 The risk of ignition is reduced by limiting the maximum temperature of components under normal operating conditions and after a single fault (see 1.4.14), or by limiting the power available in a circuit.

NOTE 2 The spread of flame in the event of ignition is reduced by the use of flame retardant materials and insulation, or by providing adequate separation.

NOTE 3 For a ranking of materials with respect to flammability, refer to the notes of 1.2.12.1.

Metals, ceramic materials and glass shall be considered to comply without test.

4.7.1 Reducing the risk of ignition and spread of flame

For equipment or a portion of equipment, there are two alternative methods of providing protection against ignition and spread of flame that could affect materials, wiring, wound components and electronic components such as integrated circuits, transistors, thyristors, diodes, resistors and capacitors.

Method 1 – Selection and application of components, wiring and materials which reduce the possibility of ignition and spread of flame and, where necessary, by the use of a FIRE ENCLOSURE. The appropriate requirements are detailed in 4.7.2 and 4.7.3. In addition, the simulated faults of 5.3.6 are applied, except for 5.3.6 c), when using this method.

NOTE 1 Method 1 may be preferred for equipment or that portion of equipment with a large number of electronic components.

Method 2 – Application of all of the simulated fault tests in 5.3.6. A FIRE ENCLOSURE is not required for equipment or that portion of equipment for which only Method 2 is used. In particular, 5.3.6 c) applies, which includes testing all relevant components in both PRIMARY CIRCUITS and SECONDARY CIRCUITS.

NOTE 2 Method 2 may be preferred for equipment or that portion of equipment with a small number of electronic components.

4.7.2 Conditions for a fire enclosure

A FIRE ENCLOSURE is required when temperatures of parts under fault conditions could be sufficient for ignition.

4.7.2.1 Parts requiring a fire enclosure

Except where Method 2 of 4.7.1 is used, or as permitted in 4.7.2.2, the following are considered to have a risk of ignition and, therefore, require a FIRE ENCLOSURE:

- components in PRIMARY CIRCUITS;
- components in SECONDARY CIRCUITS supplied by power sources which exceed the limits specified in 2.5;
- components in SECONDARY CIRCUITS supplied by limited power sources as specified in 2.5, but not mounted on material of FLAMMABILITY CLASS V-1;
- components within a power supply unit or assembly having a limited power output as specified in 2.5, including overcurrent protective devices, limiting impedances, regulating networks and wiring, up to the point where the limited power source output criteria are met;
- components having unenclosed arcing parts, such as open switch and relay contacts and commutators, in a circuit at HAZARDOUS VOLTAGE or at a HAZARDOUS ENERGY LEVEL; and
- insulated wiring.

4.7.2.2 Parts not requiring a fire enclosure

The following do not require a FIRE ENCLOSURE:

- motors;
- transformers;
- electromechanical components complying with 5.3.5;
- wiring and cables insulated with PVC, TFE, PTFE, FEP, neoprene or polyimide;
- plugs and connectors forming part of a power supply cord or INTERCONNECTING CABLE;
- components, including connectors, meeting the requirements of 4.7.3.2, which fill an opening in a FIRE ENCLOSURE;
- connectors in SECONDARY CIRCUITS supplied by power sources which are limited to a maximum of 15 VA (see 1.4.11) under normal operating conditions and after a single fault in the equipment (see 1.4.14);
- connectors in SECONDARY CIRCUITS supplied by limited power sources complying with 2.5;
- other components in SECONDARY CIRCUITS:
 - supplied by limited power sources complying with 2.5 and mounted on materials of FLAMMABILITY CLASS V-1;
 - supplied by internal or external power sources which are limited to a maximum of 15 VA (see 1.4.11) under normal operating conditions and after a single fault in the equipment (see 1.4.14) and mounted on material of FLAMMABILITY CLASS HB75 if the thinnest significant thickness of this material is <3 mm or FLAMMABILITY CLASS HB40 if the thinnest significant thickness of this material is ≥3 mm;

NOTE In Canada and the United States, additional requirements for protection from overvoltage apply for TNV CIRCUITS.

- complying with Method 2 of 4.7.1;
- equipment, or a part of the equipment, having a momentary contact switch which the USER has to activate continuously, and the release of which removes all power from the equipment or part.

Compliance with 4.7.2.1 and 4.7.2.2 is checked by inspection and by evaluation of the data provided by the manufacturer. In the case where no data is provided, compliance is determined by tests.

4.7.3 Materials

4.7.3.1 General

ENCLOSURES, components and other parts shall be so constructed, or shall make use of such materials, that the propagation of fire is limited.

Materials of FLAMMABILITY CLASSES VTM-0, VTM-1 and VTM-2 are considered to be equivalent to materials of FLAMMABILITY CLASSES V-0, V-1 and V-2, respectively, for their flammability properties. Their electrical and mechanical properties are not necessarily equivalent.

Where material of FLAMMABILITY CLASS HB40, FLAMMABILITY CLASS HB75 or FLAMMABILITY CLASS HBF, is required, material passing the glow-wire test at 550 °C according to IEC 60695-2-11 is acceptable as an alternative.

Where it is not practical to protect components against overheating under fault conditions, the components shall be mounted on materials of FLAMMABILITY CLASS V-1. Additionally, such components shall be separated from material of a class lower than FLAMMABILITY CLASS V-1 (see 1.2.12.1, note 2) by at least 13 mm of air, or by a solid barrier of material of FLAMMABILITY CLASS V-1.

NOTE 1 See also 4.7.3.5.

NOTE 2 In Canada and the United States, requirements in addition to 4.7.3.2 and 4.7.3.3 apply to ENCLOSURES and DECORATIVE PARTS having an external surface with an exposed area of greater than 0,9 m² or a single dimension greater than 1,8 m.

NOTE 3 In considering how to limit propagation of fire, and what are "small parts", account should be taken of the cumulative effect of small parts when they are adjacent to each other, and also of the possible effect of propagating fire from one part to another.

NOTE 4 The material flammability requirements in 4.7.3 are summarized in table 4D.

Compliance is checked by inspection and by evaluation of relevant data provided by the manufacturer.

4.7.3.2 Materials for fire enclosures

The following requirements apply as appropriate.

The 18 kg mass criterion applies to individual complete equipments, even if they are used in close proximity to each other (for example, one on top of another). However, if a part of the FIRE ENCLOSURE is removed in such a situation (in the same example, the bottom cover of the top equipment), the combined mass of the equipment applies. In determining the total mass of equipment, supplies, consumable materials, media and recording materials used with the equipment shall not be taken into account.

For MOVABLE EQUIPMENT having a total mass not exceeding 18 kg, the material of a FIRE ENCLOSURE, in the thinnest significant wall thickness used, shall be of FLAMMABILITY CLASS V-1 or shall pass the test of clause A.2.

For MOVABLE EQUIPMENT having a total mass exceeding 18 kg and for all STATIONARY EQUIPMENT, the material of a FIRE ENCLOSURE, in the thinnest significant wall thickness used, shall be of FLAMMABILITY CLASS 5VB or shall pass the test of clause A.1.

Materials for components which fill an opening in a FIRE ENCLOSURE, and which are intended to be mounted in this opening shall:

- be of FLAMMABILITY CLASS V-1; or
- pass the tests of clause A.2; or
- comply with the flammability requirements of the relevant IEC component standard.

NOTE Examples of these components are fuseholders, switches, pilot lights, connectors and appliance inlets.

Plastic materials of a FIRE ENCLOSURE shall be located more than 13 mm through air from arcing parts such as unenclosed commutators and unenclosed switch contacts.

Plastic materials of a FIRE ENCLOSURE located less than 13 mm through air from non-arcing parts which, under any condition of normal or abnormal operation, could attain a temperature sufficient to ignite the material, shall be capable of passing the test of IEC 60695-2-20. The average time to ignition of the samples shall be not less than 15 s. If a sample melts through without igniting, the time at which this occurs is not considered to be the time to ignition.

Compliance is checked by inspection of the equipment and material data sheets and, if necessary, by the appropriate test or tests in annex A or IEC 60695-2-20.

4.7.3.3 Materials for components and other parts outside fire enclosures

Except as otherwise noted below, materials for components and other parts (including MECHANICAL ENCLOSURES, ELECTRICAL ENCLOSURES and DECORATIVE PARTS), located outside FIRE ENCLOSURES, shall be of FLAMMABILITY CLASS HB75 if the thinnest significant thickness of this material is <3 mm, or FLAMMABILITY CLASS HB40 if the thinnest significant thickness of this material is ≥3 mm, or FLAMMABILITY CLASS HBF.

NOTE Where a MECHANICAL or an ELECTRICAL ENCLOSURE also serves as a FIRE ENCLOSURE, the requirements for FIRE ENCLOSURES apply.

Requirements for materials in air filters assemblies are in 4.7.3.5 and for materials in high-voltage components in 4.7.3.6.

Connectors shall comply with one of the following:

- be made of material of FLAMMABILITY CLASS V-2; or
- pass the tests of clause A.2; or
- comply with the flammability requirements of the relevant IEC component standard; or
- be mounted on material of FLAMMABILITY CLASS V-1 and be of a small size; or
- be located in a SECONDARY CIRCUIT supplied by a power source that is limited to a maximum of 15 VA (see 1.4.11) under normal operating conditions and after a single fault in the equipment (see 1.4.14).

The requirement for materials for components and other parts to be of FLAMMABILITY CLASS HB40, FLAMMABILITY CLASS HB75, or FLAMMABILITY CLASS HBF, does not apply to any of the following:

- electrical components which do not present a fire hazard under abnormal operating conditions when tested according to 5.3.6;
- materials and components within an ENCLOSURE of 0,06 m³ or less, consisting totally of metal and having no ventilation openings, or within a sealed unit containing an inert gas;
- meter cases (if otherwise determined to be suitable for mounting of parts at HAZARDOUS VOLTAGE), meter faces and indicator lamps or their jewels;
- components meeting the flammability requirements of a relevant IEC component standard which includes such requirements;
- electronic components, such as integrated circuit packages, opto-coupler packages, capacitors and other small parts that are:
 - mounted on material of FLAMMABILITY CLASS V-1; or
 - supplied from a power source of no more than 15 VA (see 1.4.11) under normal operating conditions or after a single fault in the equipment (see 1.4.14) and mounted on material of FLAMMABILITY CLASS HB75 if the thinnest significant thickness of this material is <3 mm, or FLAMMABILITY CLASS HB40 if the thinnest significant thickness of this material is ≥3 mm.

- wiring, cables and connectors insulated with PVC, TFE, PTFE, FEP, neoprene or polyimide;
- individual clamps (not including helical wraps or other continuous forms), lacing tape, twine and cable ties used with wiring harnesses;
- gears, cams, belts, bearings and other small parts which would contribute negligible fuel to a fire, including DECORATIVE PARTS, labels, mounting feet, key caps, knobs and the like;
- supplies, consumable materials, media and recording materials;
- parts which are required to have particular properties in order to perform intended functions, such as rubber rollers for paper pick-up and delivery, and ink tubes.

Compliance is checked by inspection of the equipment and material data sheets and, if necessary, by the appropriate test or tests in annex A.

4.7.3.4 Materials for components and other parts inside fire enclosures

Requirements for materials in air filters assemblies are in 4.7.3.5 and requirements for materials in high-voltage components in 4.7.3.6.

Inside FIRE ENCLOSURES, materials for components and other parts, (including MECHANICAL and ELECTRICAL ENCLOSURES located inside FIRE ENCLOSURES), shall comply with one of the following:

- be of FLAMMABILITY CLASS V-2 or FLAMMABILITY CLASS HF-2; or
- pass the flammability test described in clause A.2; or
- meet the flammability requirements of a relevant IEC component standard which includes such requirements.

The above requirement does not apply to any of the following:

- electrical components which do not present a fire hazard under abnormal operating conditions when tested according to 5.3.6;
- materials and components within an ENCLOSURE of 0,06 m³ or less, consisting totally of metal and having no ventilation openings, or within a sealed unit containing an inert gas;
- one or more layers of thin insulating material, such as adhesive tape, used directly on any surface within a FIRE ENCLOSURE, including the surface of current-carrying parts, provided that the combination of the thin insulating material and the surface of application complies with the requirements of FLAMMABILITY CLASS V-2, or FLAMMABILITY CLASS HF-2;

NOTE Where the thin insulating material referred to in the above exclusion is on the inner surface of the FIRE ENCLOSURE itself, the requirements in 4.6.2 continue to apply to the FIRE ENCLOSURE.

- meter cases (if otherwise determined to be suitable for mounting of parts at HAZARDOUS VOLTAGE), meter faces and indicator lamps or their jewels;
- electronic components, such as integrated circuit packages, opto-coupler packages, capacitors and other small parts that are mounted on material of FLAMMABILITY CLASS V-1;
- wiring, cables and connectors insulated with PVC, TFE, PTFE, FEP, neoprene or polyimide;

- individual clamps (not including helical wraps or other continuous forms), lacing tape, twine and cable ties used with wiring harnesses;
- the following parts, provided that they are separated from electrical parts (other than insulated wires and cables) which under fault conditions are likely to produce a temperature that could cause ignition, by at least 13 mm of air or by a solid barrier of material of FLAMMABILITY CLASS V-1:
 - gears, cams, belts, bearings and other small parts which would contribute negligible fuel to a fire, including, labels, mounting feet, key caps, knobs and the like;
 - supplies, consumable materials, media and recording materials;
 - parts which are required to have particular properties in order to perform intended functions, such as rubber rollers for paper pick-up and delivery, and ink tubes;
 - tubing for air or any fluid systems, containers for powders or liquids and foamed plastic parts, provided that they are of FLAMMABILITY CLASS HB75 if the thinnest significant thickness of the material is <3 mm, or FLAMMABILITY CLASS HB40 if the thinnest significant thickness of the material is ≥3 mm, or FLAMMABILITY CLASS HBF.

Compliance is checked by inspection of the equipment and material data sheets and, if necessary, by the appropriate test or tests of annex A.

4.7.3.5 Materials for air filter assemblies

Air filter assemblies shall be constructed of materials of FLAMMABILITY CLASS V-2, or FLAMMABILITY CLASS HF-2.

This requirement does not apply to the following constructions:

- air filter assemblies in air circulating systems, whether or not airtight, that are not intended to be vented outside the FIRE ENCLOSURE;
- air filter assemblies located inside or outside a FIRE ENCLOSURE, provided that the filter materials are separated by a metal screen from parts that could cause ignition. This screen may be perforated and shall meet the requirements of 4.6.2 for the bottoms of FIRE ENCLOSURES;
- air filter frames constructed of materials of FLAMMABILITY CLASS HB75 if the thinnest significant thickness of this material is <3 mm, or FLAMMABILITY CLASS HB40 if the thinnest significant thickness of this material is ≥3 mm, or FLAMMABILITY CLASS HBF, provided that they are separated from electrical parts (other than insulated wires and cables) which under fault conditions are likely to produce a temperature that could cause ignition, by at least 13 mm of air or by a solid barrier of material of FLAMMABILITY CLASS V-1;
- air filter assemblies located externally to the FIRE ENCLOSURE, constructed of materials of FLAMMABILITY CLASS HB75 if the thinnest significant thickness of this material is <3 mm, or FLAMMABILITY CLASS HB40 if the thinnest significant thickness of this material is ≥3 mm, or FLAMMABILITY CLASS HBF.

Compliance is checked by inspection of the equipment and material data sheets and, if necessary, by the appropriate test or tests of annex A.

4.7.3.6 Materials used in high-voltage components

High-voltage components operating at peak-to-peak voltages exceeding 4 kV shall either be of FLAMMABILITY CLASS V-2, or FLAMMABILITY CLASS HF-2, or comply with 14.4 of IEC 60065 or pass the needle flame test according to IEC 60695-2-2.

Compliance is checked by the inspection of the equipment and material data sheets and, if necessary, by the test described in 14.4 of IEC 60065 or by the needle flame test according to IEC 60695-2-2.

In addition, the following details apply, referring to clauses of IEC 60695-2-2:

Clause 5 – Severities

The test flame is applied for 10 s. If a self-sustaining flame does not last longer than 30 s, the test flame is applied again for 1 min at the same point or at any other point. If again a self-sustaining flame does not last longer than 30 s, the test flame is then applied for 2 min at the same point or at any other point.

Clause 6 – Preconditioning

Except for high voltage transformers and high voltage multipliers the samples are stored for 2 h in an oven at a temperature of $100\text{ °C} \pm 2\text{ °C}$.

For high voltage transformers, a power of 10 W (d.c. or a.c. at mains frequency) is initially supplied to the high-voltage winding. This power is maintained for 2 min, after which it is increased by successive steps of 10 W at 2 min intervals to 40 W.

The treatment lasts 8 min or is terminated as soon as interruption of the winding or appreciable splitting of the protective covering occurs.

NOTE 1 Certain transformers are so designed that this preconditioning cannot be carried out. In such cases the oven preconditioning applies.

For high-voltage multipliers, a voltage taken from an appropriate high-voltage transformer, is supplied to each sample, its output circuit being short-circuited.

The input voltage is adjusted so that the short-circuit current is initially $25\text{ mA} \pm 5\text{ mA}$. This current is maintained for 30 min or is terminated as soon as any interruption of the circuit or appreciable splitting of the protective covering occurs.

NOTE 2 Where the design of a high-voltage multiplier is such that a short-circuit current of 25 mA cannot be obtained, a preconditioning current is used, which represents the maximum attainable current, determined either by the design of the multiplier or by its conditions of use in a particular apparatus.

Clause 10 – Evaluation of test results

After the first application of the test flame, the test sample shall not be consumed completely.

After any application of the test flame, any self-sustaining flame shall extinguish within 30 s. No burning of the tissue paper shall occur and the board shall not be scorched.

Table 4D – Summary of material flammability requirements

Part		Requirement
FIRE ENCLOSURES 4.7.3.2	MOVABLE EQUIPMENT > 18 kg and STATIONARY EQUIPMENT	<ul style="list-style-type: none"> – 5VB – Test A.1 – Hot wire test of IEC 60695-2-20 (If <13 mm of air from parts at high temperatures which could cause ignition)
	MOVABLE EQUIPMENT ≤ 18 kg	<ul style="list-style-type: none"> – V-1 – Test A.2 – Hot wire test – IEC 60695-2-20 (If < 13 mm of air from parts at high temperatures which could cause ignition)
	Parts which fill an opening	<ul style="list-style-type: none"> – V-1 – Test A.2 – Component standard
Components and parts, including MECHANICAL and ELECTRICAL ENCLOSURES, outside FIRE ENCLOSURES 4.7.3.1 and 4.7.3.3		<ul style="list-style-type: none"> – HB40 for thicknesses ≥ 3 mm – HB75 for thicknesses < 3 mm – HBF – Glow-wire test 550 °C of IEC 60695-2-11 <p>For connectors and exceptions see 4.7.3.3</p>
Components and parts, including MECHANICAL and ELECTRICAL ENCLOSURES, inside FIRE ENCLOSURES 4.7.3.4		<ul style="list-style-type: none"> – V-2 – HF-2 – Test A.2 – Component standard <p>For exceptions see 4.7.3.4</p>
Air filter assemblies 4.7.3.5		<ul style="list-style-type: none"> – V-2 – HF-2 – Test A.2 <p>For exceptions see 4.7.3.5</p>
High voltage (> 4 kV) components 4.7.3.6		<ul style="list-style-type: none"> – V-2 – HF-2 – Test of IEC 60065, 14.4 – Needle flame test of IEC 60695-2-2

5 Electrical requirements and simulated abnormal conditions

5.1 Touch current and protective conductor current

In this subclause measurements of current through networks simulating the impedance of the human body are referred to as measurements of TOUCH CURRENT.

Except for application of 5.1.8.2, these requirements do not apply to equipment intended to be supplied by only a DC MAINS SUPPLY.

5.1.1 General

Equipment shall be so designed and constructed that neither TOUCH CURRENT nor PROTECTIVE CONDUCTOR CURRENT is likely to create an electric shock hazard.

Compliance is checked by testing in accordance with 5.1.2 to 5.1.7 inclusive, and, if relevant, 5.1.8 (see also 1.4.4).

However, if it is clear from a study of the circuit diagrams of either PERMANENTLY CONNECTED EQUIPMENT or PLUGGABLE EQUIPMENT TYPE B, that has a PROTECTIVE EARTHING CONDUCTOR, that the TOUCH CURRENT will exceed 3,5 mA r.m.s., but that the PROTECTIVE CONDUCTOR CURRENT will not exceed 5 % of input current, the tests of 5.1.5, 5.1.6 and 5.1.7 are not made.

5.1.2 Equipment under test (EUT)

Systems of interconnected equipment with individual connections to the AC MAINS SUPPLY shall have each piece of equipment tested separately. Systems of interconnected equipment with one common connection to the AC MAINS SUPPLY shall be treated as a single piece of equipment. See also 1.4.10 regarding the inclusion of optional features.

NOTE Systems of interconnected equipment are specified in more detail in IEC 60990, annex A.

Equipment which is designed for connection to multiple power sources, only one of which is required at a time (for example, for backup) shall be tested with only one source connected.

Equipment requiring power simultaneously from two or more power sources shall be tested with all power sources connected.

5.1.3 Test circuit

Equipment is tested using the test circuit in figure 5A (for single-phase equipment to be connected only to a star TN or TT power distribution system) or figure 5B (for three-phase equipment to be connected only to a star TN or TT power distribution system) or where appropriate, another test circuit from IEC 60990, figures 7, 9, 10, 12, 13 or 14.

The use of a test transformer for isolation is optional. For maximum protection, a test transformer for isolation (T in figures 5A and 5B) is used and the main protective earthing terminal of the EUT is earthed. Any capacitive leakage in the transformer shall then be taken into account. As an alternative to earthing the EUT, the test transformer secondary and the EUT are left floating (not earthed) in which case capacitive leakage in the transformer need not be taken into account.

If transformer *T* is not used, the equipment is mounted on an insulating stand, and appropriate safety precautions are taken in view of the possibility of the BODY of the equipment being at a HAZARDOUS VOLTAGE.

Equipment to be connected to an IT power distribution system is tested accordingly (see figures 9, 10 and 12 of IEC 60990). Such equipment may also be connected to a TN or TT power distribution system.

Single-phase equipment intended to be operated between two line conductors is tested using a three-phase test circuit such as figure 5B.

If it is inconvenient to test equipment at the most unfavourable supply voltage (see 1.4.5), it is permitted to test the equipment at any available voltage within the tolerance of RATED VOLTAGE or within the RATED VOLTAGE RANGE, and then calculate the results.

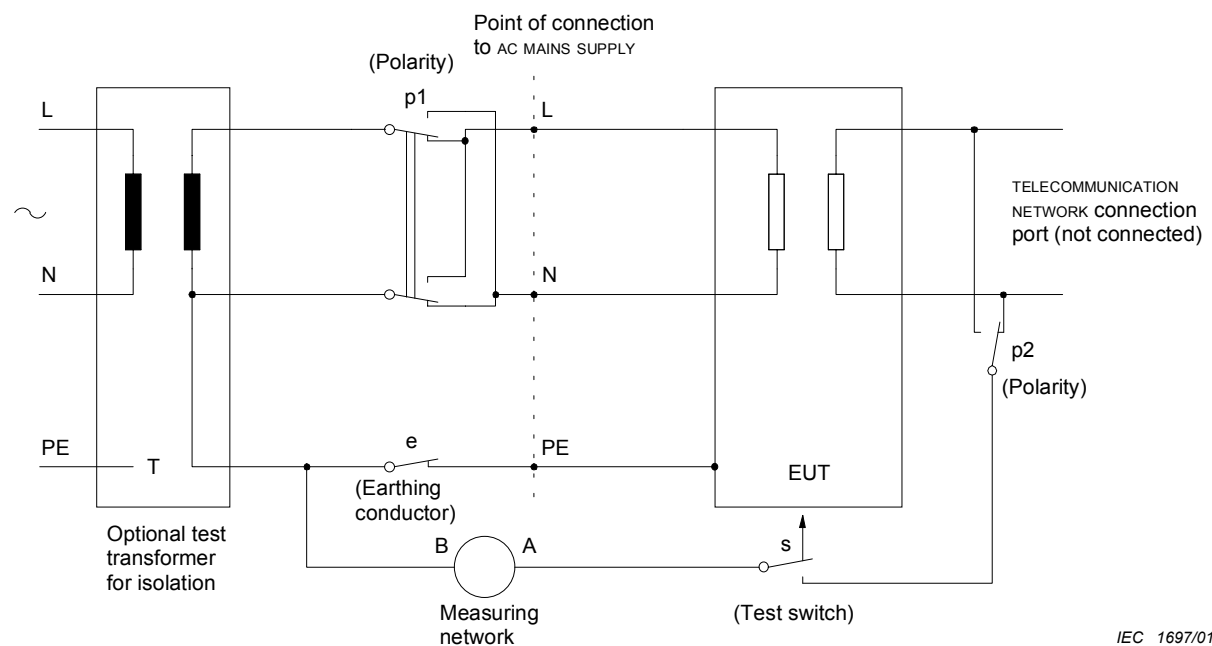

IEC 1697/01

NOTE This figure is derived from IEC 60990, figure 6.

Figure 5A – Test circuit for touch current of single-phase equipment on a star TN or TT power supply system

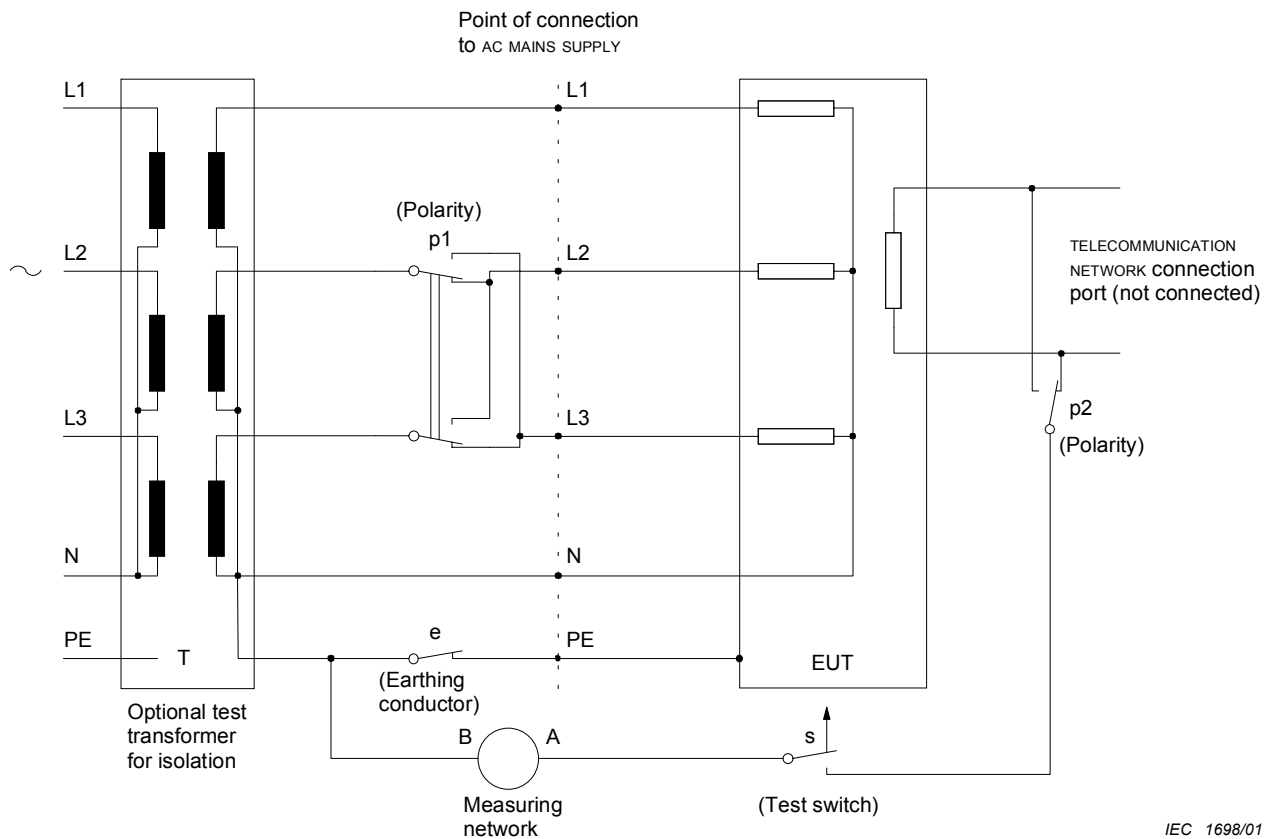

NOTE This figure is derived from IEC 60990, figure 11.

Figure 5B – Test circuit for touch current of three-phase equipment on a star TN or TT power supply system

5.1.4 Application of measuring instrument

Tests are conducted using one of the measuring instruments in annex D, or any other circuit giving the same results.

Terminal B of the measuring instrument is connected to the earthed (neutral) conductor of the supply (see figure 5A or 5B).

Terminal A of the measuring instrument is connected as specified in 5.1.5.

For an accessible non-conductive part, the test is made to metal foil having dimensions of 10 cm × 20 cm in contact with the part. If the area of the foil is smaller than the surface under test, the foil is moved so as to test all parts of the surface. Where adhesive metal foil is used, the adhesive shall be conductive. Precautions are taken to prevent the metal foil from affecting the heat dissipation of the equipment.

NOTE 1 The foil test simulates hand contact.

Accessible conductive parts that are incidentally connected to other parts are tested both as connected and disconnected parts.

NOTE 2 Incidentally connected parts are described in more detail in IEC 60990, annex C.

5.1.5 Test procedure

For equipment having a protective earthing connection or a FUNCTIONAL EARTHING connection, terminal A of the measuring instrument is connected via measurement switch "s" to the equipment earthing terminal of the EUT, with the earthing conductor switch "e" open.

The test is also carried out, on all equipment, with terminal A of the measuring network connected via measurement switch "s" to each unearthed or non-conductive accessible part and each unearthed accessible circuit, in turn, with the earthing conductor switch "e" closed.

Additionally:

- for single-phase equipment, the tests are repeated in reverse polarity (switch "p1");*
- for three-phase equipment, the tests are repeated in reverse polarity (switch "p1") unless the equipment is sensitive to phase sequence.*

When testing three-phase equipment, any components used for EMC purposes and connected between line and earth are disconnected one at a time; for this purpose, groups of components in parallel connected through a single connection are treated as single components. Each time a line-to-earth component is disconnected the sequence of switch operations is repeated.

NOTE Where filters are normally encapsulated, it may be necessary to provide an unencapsulated unit for test or to simulate the filter network.

For each placement of the measuring instrument, any switches in the PRIMARY CIRCUIT and likely to be operated in normal use are open and closed in all possible combinations.

After applying each test condition, the equipment is restored to its original condition, that is without fault or consequential damage.

5.1.6 Test measurements

Either the r.m.s. value of the voltage, U_2 , is measured using the measuring instrument of figure D.1, or the r.m.s. value of the current is measured using the measuring instrument of figure D.2.

The D.1 instrument gives a more accurate measurement than the D.2 instrument if the waveform is non-sinusoidal and the fundamental frequency exceeds 100 Hz.

Alternatively, the peak value of the voltage, U_2 , is measured using the measuring instrument described in clause D.1.

If the voltage, U_2 , is measured using the measuring instrument described in clause D.1, the following calculation is used:

$$\text{TOUCH CURRENT (A)} = U_2 / 500$$

NOTE Although r.m.s. values of TOUCH CURRENT have traditionally been measured, peak values provide better correlation with the response of the human body to non-sinusoidal current waveforms.

None of the values measured in accordance with 5.1.6 shall exceed the relevant limits in table 5A, except as permitted in 5.1.7.

Table 5A – Maximum current

Type of equipment	Terminal A of measuring instrument connected to:	Maximum TOUCH CURRENT mA r.m.s. ¹⁾	Maximum PROTECTIVE CONDUCTOR CURRENT
All equipment	Accessible parts and circuits not connected to protective earth	0,25	–
HAND-HELD	Equipment main protective earthing terminal (if any)	0,75	–
MOVABLE (other than HAND-HELD, but including TRANSPORTABLE EQUIPMENT)		3,5	–
STATIONARY, PLUGGABLE TYPE A		3,5	–
All other STATIONARY EQUIPMENT		3,5	–
– not subject to the conditions of 5.1.7	5 % of input current		
– subject to the conditions of 5.1.7	–	–	5 % of input current
¹⁾ If peak values of TOUCH CURRENT are measured, the maximum values are obtained by multiplying the r.m.s. values in the table by 1,414.			

5.1.7 Equipment with touch current exceeding 3,5 mA

For STATIONARY PERMANENTLY CONNECTED EQUIPMENT or STATIONARY PLUGGABLE EQUIPMENT TYPE B having a main protective earthing terminal, if the TOUCH CURRENT measurements exceed 3,5 mA r.m.s., all of the following conditions apply:

- the r.m.s. PROTECTIVE CONDUCTOR CURRENT shall not exceed 5 % of the input current per line under normal operating conditions. If the load is unbalanced, the largest of the three line currents shall be used for this calculation. To measure the PROTECTIVE CONDUCTOR CURRENT, the procedure for measuring TOUCH CURRENT is used but the measuring instrument is replaced by an ammeter of negligible impedance; and
- the cross-sectional area of the PROTECTIVE BONDING CONDUCTOR shall be not be less than that of the conductors in table 3B (see 3.2.5), with a minimum of 1,0 mm² in the path of high PROTECTIVE CONDUCTOR CURRENT; and
- one of the following labels, or a label with similar wording, shall be affixed adjacent to the equipment AC MAINS SUPPLY connection:

WARNING
HIGH LEAKAGE CURRENT
EARTH CONNECTION ESSENTIAL
BEFORE CONNECTING SUPPLY

WARNING
HIGH TOUCH CURRENT
EARTH CONNECTION ESSENTIAL
BEFORE CONNECTING SUPPLY

NOTE Attention is drawn to IEC 60364-7-707.

Compliance is checked by inspection and measurement.

5.1.8 Touch currents to telecommunication networks and cable distribution systems and from telecommunication networks

NOTE In this subclause, references to "TELECOMMUNICATION NETWORK connection ports" (or telecommunication ports) are intended to cover those connection points to which a TELECOMMUNICATION NETWORK is intended to be attached. Such references are not intended to include other data ports, such as those commonly identified as serial, parallel, keyboard, game, joystick, etc.

5.1.8.1 Limitation of the touch current to a telecommunication network and a cable distribution system

The TOUCH CURRENT from equipment supplied from the AC MAINS SUPPLY to a TELECOMMUNICATION NETWORK or a CABLE DISTRIBUTION SYSTEM shall be limited.

Compliance is checked using the test circuit detailed in 5.1.3.

The tests are not applied to equipment where the circuit to be connected to a TELECOMMUNICATION NETWORK or a CABLE DISTRIBUTION SYSTEM is connected to a protective earthing terminal in the equipment; the TOUCH CURRENT from the EUT to the TELECOMMUNICATION NETWORK or the CABLE DISTRIBUTION SYSTEM is considered to be zero.

For equipment having more than one circuit to be connected to a TELECOMMUNICATION NETWORK or a CABLE DISTRIBUTION SYSTEM, the test is applied to only one example of each type of circuit.

For equipment that has no main protective earthing terminal, the earthing conductor switch "e", if connected to a FUNCTIONAL EARTHING terminal on the EUT, is left open. Otherwise it is closed.

Terminal B of the measuring instrument is connected to the earthed (neutral) conductor of the supply. Terminal A is connected via the measurement switch "s" and the polarity switch "p2" to the TELECOMMUNICATION NETWORK or CABLE DISTRIBUTION SYSTEM connection port.

For single-phase equipment, the test is made in all combinations of the polarity switches "p1" and "p2".

For three-phase equipment, the test is made in both positions of polarity switch "p2".

After applying each test condition, the equipment is restored to its original operating state.

Test measurements are made using one of the measuring instruments of annex D as described in 5.1.6.

None of the values measured in accordance with 5.1.8.1 shall exceed 0,25 mA r.m.s.

5.1.8.2 Summation of touch currents from telecommunication networks

NOTE Annex W explains the background to 5.1.8.2.

An EUT that provides TELECOMMUNICATION NETWORK connection ports for connection of multiple items of other telecommunication equipment, shall not create a hazard for USERS and TELECOMMUNICATION NETWORK SERVICE PERSONS due to summation of TOUCH CURRENT.

In these requirements, abbreviations have the following meanings:

- I_1 is the TOUCH CURRENT received from other equipment via a TELECOMMUNICATION NETWORK at a telecommunication port of the EUT;
- $\sum I_1$ is the summation of TOUCH CURRENTS received from other equipment at all such telecommunication ports of the EUT;
- I_2 is the TOUCH CURRENT due to the AC MAINS SUPPLY of the EUT.

It shall be assumed that each telecommunication port receives 0,25 mA (I_1) from the other equipment, unless the actual current from the other equipment is known to be lower.

The following requirements, a) or b) as applicable, shall be met:

a) EUT with earthed telecommunication ports

For an EUT in which each telecommunication port is connected to the main protective earthing terminal of the EUT, the following items 1), 2) and 3) shall be considered:

- 1) If $\sum I_1$ (not including I_2) exceeds 3,5 mA:
 - the equipment shall have provision for a permanent connection to protective earth in addition to the PROTECTIVE EARTHING CONDUCTOR in the power supply cord of PLUGGABLE EQUIPMENT TYPE A or B; and
 - the installation instructions shall specify the provision of a permanent connection to protective earth with a cross-sectional area of not less than 2,5 mm², if mechanically protected, or otherwise 4,0 mm²; and
 - one of the following labels, or a label with similar wording, shall be affixed adjacent to the permanent earth connection, it is permitted to combine this label with the label in 5.1.7.

WARNING
HIGH LEAKAGE CURRENT
EARTH CONNECTION ESSENTIAL
BEFORE MAKING
TELECOMMUNICATION NETWORK
CONNECTIONS

WARNING
HIGH TOUCH CURRENT
EARTH CONNECTION ESSENTIAL
BEFORE MAKING
TELECOMMUNICATION NETWORK
CONNECTIONS

- 2) $\sum I_1$ plus I_2 shall comply with the limits in table 5A (see 5.1.6).
- 3) If relevant, such equipment shall comply with 5.1.7. The value of I_2 shall be used to calculate the 5 % input current limit per phase specified in 5.1.7.

Compliance with item a) is checked by inspection and if necessary by test.

If the equipment has provision for a permanent protective earth connection in accordance with item 1) above, it is not necessary to make any measurements, except that I_2 shall comply with the relevant requirements of 5.1.

TOUCH CURRENT tests, if necessary, are made using the relevant measuring instrument described in annex D or any other instrument giving the same results. A capacitively coupled a.c. source of the same line frequency and phase as the AC MAINS SUPPLY is applied to each telecommunication port such that 0,25 mA, or the actual current from other equipment if known to be lower, is available to flow into that telecommunication port. The current flowing in the earthing conductor is then measured.

b) EUT whose telecommunication ports have no reference to protective earth

If the telecommunication ports on the EUT do not have a common connection, each telecommunication port shall comply with 5.1.8.1.

If all telecommunication ports or any groups of such ports have a common connection, the total TOUCH CURRENT from each common connection shall not exceed 3,5 mA.

Compliance with item b) is checked by inspection and if necessary by the tests of 5.1.8.1 or, if there are common connection points, by the following test.

A capacitively coupled a.c. source of the same frequency and phase as the AC MAINS SUPPLY is applied to each telecommunication port such that 0,25 mA, or the actual current from the other equipment if known to be lower, is available to flow into that telecommunication port. Common connection points are tested in accordance with 5.1, whether or not the points are accessible.

5.2 Electric strength

NOTE Where specific reference to conducting the electric strength test according to 5.2 is made in other parts of this standard, it is intended that the electric strength test be conducted with the equipment in a well-heated condition according to 5.2.1.

Where specific reference to conducting the electric strength test according to 5.2.2 is made in other parts of this standard, it is intended that the electric strength test be conducted without preheating according to 5.2.1.

5.2.1 General

The electric strength of the solid insulation used in the equipment shall be adequate.

Compliance is checked in accordance with 5.2.2 while the equipment is still in a well-heated condition immediately following the heating test as specified in 4.5.1.

If components or subassemblies are tested separately outside the equipment, they are brought to the temperature attained by that part during the heating test (for example, by placing them in an oven) prior to performing the electric strength test. However, it is permitted to conduct electric strength testing of thin sheet material for SUPPLEMENTARY INSULATION or REINFORCED INSULATION, referenced in 2.10.5.2, at room temperature.

5.2.2 Test procedure

The insulation is subjected either to a voltage of substantially sine-wave form having a frequency of 50 Hz or 60 Hz, or to a DC VOLTAGE equal to the peak voltage of the prescribed a.c. test voltage. Unless otherwise specified elsewhere in this standard, test voltages are as specified in table 5B for the appropriate grade of INSULATION (FUNCTIONAL, BASIC, SUPPLEMENTARY or REINFORCED) and the WORKING VOLTAGE (U), determined in 2.10.2, across the insulation. DC values of WORKING VOLTAGE shall be used for DC VOLTAGES and peak values for other voltages.

The voltage applied to the insulation under test is gradually raised from zero to the prescribed voltage and held at that value for 60 s.

NOTE 1 For ROUTINE TESTS specified elsewhere in this standard, it is permitted to reduce the duration of the electric strength test to 1 s.

There shall be no insulation breakdown during the test.

Insulation breakdown is considered to have occurred when the current which flows as a result of the application of the test voltage rapidly increases in an uncontrolled manner, that is the insulation does not restrict the flow of the current. Corona discharge or a single momentary flashover is not regarded as insulation breakdown.

Insulation coatings are tested with metal foil in contact with the insulating surface. This procedure is limited to places where the insulation is likely to be weak, for example, where there are sharp metal edges under the insulation. If practicable, insulating linings are tested separately. Care is taken that the metal foil is so placed that no flashover occurs at the edges of the insulation. Where adhesive metal foil is used, the adhesive shall be conductive.

To avoid damage to components or insulation which are not involved in the test, disconnection of integrated circuits or the like and the use of equipotential bonding are permitted.

For equipment incorporating both REINFORCED INSULATION and lower grades of insulation, care is taken that the voltage applied to the REINFORCED INSULATION does not overstress BASIC INSULATION or SUPPLEMENTARY INSULATION.

NOTE 2 Where there are capacitors across the insulation under test (for example, radio-frequency filter capacitors), it is recommended that d.c. test voltages are used.

NOTE 3 Components providing a d.c. path in parallel with the insulation to be tested, such as discharge resistors for filter capacitors and voltage limiting devices, should be disconnected.

Where insulation of a transformer winding varies along the length of the winding in accordance with 2.10.10, an electric strength test method is used that stresses the insulation accordingly.

NOTE 4 An example of such a test method is an induced voltage test which is applied at a frequency sufficiently high to avoid saturation of the transformer. The input voltage is raised to a value which would induce an output voltage equal to the required test voltage.

No test is applied to FUNCTIONAL INSULATION, unless 5.3.4 b) has been selected.

**Table 5B – Test voltages for electric strength tests
Part 1**

Grade of Insulation	Points of application (as appropriate)						
	PRIMARY CIRCUIT to BODY PRIMARY CIRCUIT to SECONDARY CIRCUIT between parts in PRIMARY CIRCUITS					SECONDARY CIRCUIT to BODY between independent SECONDARY CIRCUITS	
	WORKING VOLTAGE					WORKING VOLTAGE	
	$U \leq 184 \text{ V}$ peak or d.c. ²⁾	$184 \text{ V} < U \leq 354 \text{ V}$ peak or d.c. ³⁾	$354 \text{ V} < U \leq 1,41 \text{ kV}$ peak or d.c.	$1,41 \text{ kV} < U \leq 10 \text{ kV}$ peak or d.c. ⁴⁾	$10 \text{ kV} < U \leq 50 \text{ kV}$ peak or d.c.	$U \leq 42,4 \text{ V}$ peak or 60 V d.c. ⁵⁾	$42,4 \text{ V}$ peak or 60 V d.c. < $U \leq 10 \text{ kV}$ peak or d.c. ⁵⁾
	Test voltage, volts r.m.s. ¹⁾					Test voltage, voltage r.m.s. ¹⁾	
FUNCTIONAL	1 000	1 500	see V_a in table 5B, part 2	see V_a in table 5B, part 2	$1,06 U$	500	see V_a in table 5B, part 2
BASIC, SUPPLEMENTARY	1 000	1 500	see V_a in table 5B, part 2	see V_a in table 5B, part 2	$1,06 U$	No test	see V_a in table 5B, part 2
REINFORCED	2 000	3 000	3 000	see V_b in table 5B, part 2	$1,06 U$	No test	see V_b in table 5B, part 2

1) For WORKING VOLTAGES exceeding 10 kV peak or d.c. in SECONDARY CIRCUITS, the same test voltages as for PRIMARY CIRCUITS apply.

2) Use this column for a DC MAINS SUPPLY up to and including 184 V d.c. and subject to MAINS TRANSIENT VOLTAGES.

3) Use this column for a DC MAINS SUPPLY over 184 V d.c., up to and including 354 V d.c. and subject to MAINS TRANSIENT VOLTAGES.

4) Use this column for a DC MAINS SUPPLY over 354 V d.c. and subject to MAINS TRANSIENT VOLTAGES.

5) Use these columns for d.c. derived within the equipment from a.c. supplies, or to d.c. derived from equipment within the same building.

**Table 5B – Test voltages for electric strength tests
Part 2**

U peak or d.c.	V_a r.m.s.	V_b r.m.s.	U peak or d.c.	V_a r.m.s.	V_b r.m.s.	U peak or d.c.	V_a r.m.s.	V_b r.m.s.
34	500	800	250	1 261	2 018	1 750	3 257	3 257
35	507	811	260	1 285	2 055	1 800	3 320	3 320
36	513	821	270	1 307	2 092	1 900	3 444	3 444
38	526	842	280	1 330	2 127	2 000	3 566	3 566
40	539	863	290	1 351	2 162	2 100	3 685	3 685
42	551	882	300	1 373	2 196	2 200	3 803	3 803
44	564	902	310	1 394	2 230	2 300	3 920	3 920
46	575	920	320	1 414	2 263	2 400	4 034	4 034
48	587	939	330	1 435	2 296	2 500	4 147	4 147
50	598	957	340	1 455	2 328	2 600	4 259	4 259
52	609	974	350	1 474	2 359	2 700	4 369	4 369
54	620	991	360	1 494	2 390	2 800	4 478	4 478
56	630	1 008	380	1 532	2 451	2 900	4 586	4 586
58	641	1 025	400	1 569	2 510	3 000	4 693	4 693
60	651	1 041	420	1 605	2 567	3 100	4 798	4 798
62	661	1 057	440	1 640	2 623	3 200	4 902	4 902
64	670	1 073	460	1 674	2 678	3 300	5 006	5 006
66	680	1 088	480	1 707	2 731	3 400	5 108	5 108
68	690	1 103	500	1 740	2 784	3 500	5 209	5 209
70	699	1 118	520	1 772	2 835	3 600	5 309	5 309
72	708	1 133	540	1 803	2 885	3 800	5 507	5 507
74	717	1 147	560	1 834	2 934	4 000	5 702	5 702
76	726	1 162	580	1 864	2 982	4 200	5 894	5 894
78	735	1 176	588	1 875	3 000	4 400	6 082	6 082
80	744	1 190	600	1 893	3 000	4 600	6 268	6 268
85	765	1 224	620	1 922	3 000	4 800	6 452	6 452
90	785	1 257	640	1 951	3 000	5 000	6 633	6 633
95	805	1 288	660	1 979	3 000	5 200	6 811	6 811
100	825	1 319	680	2 006	3 000	5 400	6 987	6 987
105	844	1 350	700	2 034	3 000	5 600	7 162	7 162
110	862	1 379	720	2 060	3 000	5 800	7 334	7 334
115	880	1 408	740	2 087	3 000	6 000	7 504	7 504
120	897	1 436	760	2 113	3 000	6 200	7 673	7 673
125	915	1 463	780	2 138	3 000	6 400	7 840	7 840
130	931	1 490	800	2 164	3 000	6 600	8 005	8 005
135	948	1 517	850	2 225	3 000	6 800	8 168	8 168
140	964	1 542	900	2 285	3 000	7 000	8 330	8 330
145	980	1 568	950	2 343	3 000	7 200	8 491	8 491
150	995	1 593	1 000	2 399	3 000	7 400	8 650	8 650
152	1 000	1 600	1 050	2 454	3 000	7 600	8 807	8 807
1) 155	1 000	1 617	1 100	2 508	3 000	7 800	8 964	8 964
1) 160	1 000	1 641	1 150	2 560	3 000	8 000	9 119	9 119
1) 165	1 000	1 664	1 200	2 611	3 000	8 200	9 273	9 273
1) 170	1 000	1 688	1 250	2 661	3 000	8 400	9 425	9 425
1) 175	1 000	1 711	1 300	2 710	3 000	8 600	9 577	9 577
1) 180	1 000	1 733	1 350	2 758	3 000	8 800	9 727	9 727
1) 184	1 000	1 751	1 400	2 805	3 000	9 000	9 876	9 876
185	1 097	1 755	1 410	2 814	3 000	9 200	10 024	10 024
190	1 111	1 777	1 450	2 868	3 000	9 400	10 171	10 171
200	1 137	1 820	1 500	2 934	3 000	9 600	10 317	10 317
210	1 163	1 861	1 550	3 000	3 000	9 800	10 463	10 463
220	1 189	1 902	1 600	3 065	3 065	10 000	10 607	10 607
230	1 214	1 942	1 650	3 130	3 130			
240	1 238	1 980	1 700	3 194	3 194			

1) At these voltages, the values of V_b are determined by the general curve $V_b = 155,86 U^{0,4638}$ and are not $1,6 V_a$.

2) Linear interpolation is permitted between adjacent points in the table.

5.3 Abnormal operating and fault conditions

5.3.1 Protection against overload and abnormal operation

Equipment shall be so designed that the risk of fire or electric shock due to mechanical or electrical overload or failure, or due to abnormal operation or careless use, is limited as far as practicable.

After abnormal operation or a single fault (see 1.4.14), the equipment shall remain safe for an OPERATOR in the meaning of this standard, but it is not required that the equipment should still be in full working order. It is permitted to use fusible links, THERMAL CUT-OUTS, overcurrent protection devices and the like to provide adequate protection.

Compliance is checked by inspection and by the tests of 5.3. Before the start of each test, it is checked that the equipment is operating normally.

If a component or subassembly is so enclosed that short-circuiting or disconnection as specified in 5.3 is not practicable or is difficult to perform without damaging the equipment, it is permitted to make the tests on sample parts provided with special connecting leads. If this is not possible or not practical, the component or subassembly as a whole shall pass the tests.

Equipment is tested by applying any condition that may be expected in normal use and foreseeable misuse.

In addition, equipment which is provided with a protective covering is tested with the covering in place under normal idling conditions until steady conditions are established.

5.3.2 Motors

Under overload, locked rotor and other abnormal conditions, motors shall not cause a hazard due to excessive temperatures.

NOTE Methods of achieving this include the following:

- the use of motors which do not overheat under locked-rotor conditions (protection by inherent or external impedance);
- the use in SECONDARY CIRCUITS of motors which may exceed the permitted temperature limits but which do not create a hazard;
- the use of a device responsive to motor current;
- the use of an integral THERMAL CUT-OUT;
- the use of a sensing circuit which disconnects power from the motor in a sufficiently short time to prevent overheating if, for example, the motor fails to perform its intended function.

Compliance is checked by the applicable test of annex B.

5.3.3 Transformers

Transformers shall be protected against overload, for example, by:

- overcurrent protection;
- internal THERMAL CUT-OUTS;
- use of current limiting transformers.

Compliance is checked by the applicable tests of clause C.1.

5.3.4 Functional insulation

For FUNCTIONAL INSULATION, CLEARANCES and CREEPAGE DISTANCES shall satisfy one of the following requirements a), b) or c).

For insulation between a SECONDARY CIRCUIT and an inaccessible conductive part that is earthed for functional reasons, CLEARANCES and CREEPAGE DISTANCES shall satisfy a), b) or c).

- a) They meet the CLEARANCE and CREEPAGE DISTANCE requirements for FUNCTIONAL INSULATION in 2.10.
- b) They withstand the electric strength tests for FUNCTIONAL INSULATION in 5.2.2.
- c) They are short-circuited where a short circuit could cause:
 - 1) overheating of any material creating a risk of fire, unless the material that could be overheated is of FLAMMABILITY CLASS V-1; or
 - 2) thermal damage to BASIC INSULATION, SUPPLEMENTARY INSULATION or REINFORCED INSULATION, thereby creating a risk of electric shock.

Compliance criteria for 5.3.4 c) are in 5.3.8.

5.3.5 Electromechanical components

Where a hazard is likely to occur, electromechanical components other than motors are checked for compliance with 5.3.1 by applying the following conditions:

- *mechanical movement shall be locked in the most disadvantageous position while the component is energized normally; and*
- *in the case of a component which is normally energized intermittently, a fault shall be simulated in the drive circuit to cause continuous energizing of the component.*

The duration of each test shall be as follows:

- *for equipment or components whose failure to operate is not evident to the OPERATOR: as long as necessary to establish steady conditions or up to the interruption of the circuit due to other consequences of the simulated fault condition, whichever is the shorter; and*
- *for other equipment and components: 5 min or up to interruption of the circuit due to a failure of the component (for example, burn-out) or to other consequences of the simulated fault condition, whichever is the shorter.*

For compliance criteria see 5.3.8.

5.3.6 Simulation of faults

For components and circuits other than those covered by 5.3.2, 5.3.3 and 5.3.5, compliance is checked by simulating single fault conditions (see 1.4.14).

The following faults are simulated.

- a) *Short circuit or disconnection of any components in PRIMARY CIRCUITS.*
- b) *Short circuit or disconnection of any components where failure could adversely affect SUPPLEMENTARY INSULATION or REINFORCED INSULATION.*

- c) *Short circuit, disconnection or overloading of all relevant components and parts unless they comply with the requirements of 4.7.3.*

NOTE 1 An overload condition is any condition between NORMAL LOAD and maximum current condition up to short circuit.

- d) *Faults arising from connection of the most unfavourable load impedance to terminals and connectors that deliver power or signal outputs from the equipment, other than mains power outlets.*

Where there are multiple outlets having the same internal circuitry, the test is only made on one sample outlet.

For components in PRIMARY CIRCUITS associated with the mains input, such as the supply cord, appliance couplers, EMC filtering components, switches and their interconnecting wiring, no fault is simulated, provided that the component complies with 5.3.4 a).

NOTE 2 Such components are still subject to other requirements of this standard where applicable, including 1.5.1, 2.10.5, 4.7.3 and 5.2.2.

In addition to the compliance criteria given in 5.3.8, temperatures in the transformer supplying the component under test shall not exceed those specified in clause C.1, and account shall be taken of the exception detailed in clause C.1 regarding transformers that would require replacement.

5.3.7 Unattended equipment

Equipment intended for unattended use and having THERMOSTATS, TEMPERATURE LIMITERS and THERMAL CUT-OUTS, or having a capacitor not protected by a fuse or the like connected in parallel with the contacts, is subjected to the following tests.

THERMOSTATS, TEMPERATURE LIMITERS and THERMAL CUT-OUTS are also assessed for compliance with the requirements in clause K.6.

Equipment is operated under the conditions specified in 4.5.1 and any control that serves to limit the temperature is short-circuited. If the equipment is provided with more than one THERMOSTAT, TEMPERATURE LIMITER or THERMAL CUT-OUT, each is short-circuited, one at a time.

If interruption of the current does not occur, the equipment is switched off as soon as steady conditions are established and is permitted to cool down to approximately room temperature.

For equipment rated for only SHORT-TIME OPERATION, the duration of the test is equal to the RATED OPERATING TIME.

For equipment rated for SHORT-TIME OPERATION or INTERMITTENT OPERATION, the test is repeated until steady-state conditions are reached, irrespective of the RATED OPERATING TIME. For this test the THERMOSTATS, TEMPERATURE LIMITERS and THERMAL CUT-OUTS are not short-circuited.

If in any test a MANUAL-RESET THERMAL CUT-OUT operates, or if the current is otherwise interrupted before steady conditions are reached, the heating period is taken to have ended; but if the interruption is due to the rupture of an intentionally weak part, the test is repeated on a second sample. Both samples shall comply with the conditions specified in 5.3.8.

5.3.8 Compliance criteria for abnormal operating and fault conditions

5.3.8.1 During the tests

During the tests of 5.3.4 c), 5.3.5, 5.3.6, 5.3.7 and clause C.1:

- *if a fire occurs it shall not propagate beyond the equipment; and*
- *the equipment shall not emit molten metal; and*
- *ENCLOSURES shall not deform in such a way as to cause non-compliance with 2.1.1, 2.6.1, 2.10.3 and 4.4.1.*

Moreover, during the tests of 5.3.6 c), unless otherwise specified the temperatures of insulating materials other than thermoplastic materials shall not exceed 150 °C for Class A, 165 °C for Class E, 175 °C for Class B, 190 °C for Class F and 210 °C for Class H materials.

If the failure of the insulation would not result in HAZARDOUS VOLTAGES or HAZARDOUS ENERGY LEVELS becoming accessible, a maximum temperature of 300 °C is permitted. Higher temperatures are permitted for insulation made of glass or ceramic material.

5.3.8.2 After the tests

After the tests of 5.3.4 c), 5.3.5, 5.3.6 and 5.3.7 and clause C.1, an electric strength test according to 5.2.2 is made on:

- *REINFORCED INSULATION; and*
- *BASIC INSULATION or SUPPLEMENTARY INSULATION forming part of DOUBLE INSULATION; and*
- *BASIC INSULATION between the PRIMARY CIRCUIT and the protective earthing terminal;*

if any of the following applies:

- *the CLEARANCE or CREEPAGE DISTANCE has been reduced below the value specified in 2.10; or*
- *the insulation shows visible signs of damage; or*
- *the insulation cannot be inspected.*

6 Connection to telecommunication networks

If the equipment is to be connected to a TELECOMMUNICATION NETWORK, the requirements of clause 6 apply in addition to the requirements of clauses 1 to 5 in this standard.

NOTE 1 It is assumed that adequate measures according to ITU-T Recommendation K.11 have been taken to reduce the likelihood that the overvoltages presented to the equipment exceed 1,5 kV peak. In installations where overvoltages presented to the equipment may exceed 1,5 kV peak, additional measures such as surge suppression may be necessary.

NOTE 2 Legal requirements may exist regarding the connection of information technology equipment to a TELECOMMUNICATION NETWORK operated by a public network operator.

NOTE 3 The requirements of 2.3.2, 6.1.2 and 6.2 can apply to the same physical insulation or CLEARANCE.

NOTE 4 The AC MAINS SUPPLY system, if used as a communication transmission medium, is not a TELECOMMUNICATION NETWORK (see 1.2.13.8), and clause 6 does not apply. The other clauses of this standard will apply to coupling components, such as signal transformers, connected between the mains and other circuitry. The requirements for DOUBLE INSULATION or REINFORCED INSULATION will generally apply. See also IEC 60664-1 for overvoltages to be expected at various points in the AC MAINS SUPPLY system.

6.1 Protection of telecommunication network service persons, and users of other equipment connected to the network, from hazards in the equipment

6.1.1 Protection from hazardous voltages

Circuitry intended to be directly connected to a TELECOMMUNICATION NETWORK shall comply with the requirements for an SELV CIRCUIT or a TNV CIRCUIT.

Where protection of the TELECOMMUNICATION NETWORK relies on the protective earthing of the equipment, the installation instructions and other relevant literature shall state that integrity of protective earthing shall be ensured (see also 1.7.2).

Compliance is checked by inspection and measurement.

6.1.2 Separation of the telecommunication network from earth

6.1.2.1 Requirements

Except as specified in 6.1.2.2, there shall be insulation between circuitry intended to be connected to a TELECOMMUNICATION NETWORK and any parts or circuitry that will be earthed in some applications, either within the EUT or via other equipment.

Surge suppressors that bridge the insulation shall have a minimum d.c. sparkover voltage of 1,6 times the RATED VOLTAGE or 1,6 times the upper voltage of the RATED VOLTAGE RANGE of the equipment.

Compliance is checked by inspection and by the following tests.

NOTE In Finland, Norway and Sweden, there are additional requirements for the insulation.

Insulation is subjected to an electric strength test according to 5.2.2. The a.c. test voltage is as follows:

- *for equipment intended to be installed in an area where the nominal AC MAINS SUPPLY voltage exceeds 130 V: 1,5 kV*
- *for all other equipment: 1,0 kV*

The test voltages apply whether or not the equipment is powered from the AC MAINS SUPPLY.

Components bridging the insulation that are left in place during electric strength testing shall not be damaged. There shall be no breakdown of insulation during electric strength testing.

It is permitted to remove components that bridge the insulation, other than capacitors, during electric strength testing. If this option is chosen, an additional test with a test circuit according to figure 6A is performed with all components in place. The test is performed with a voltage equal to the RATED VOLTAGE of the equipment or to the upper voltage of the RATED VOLTAGE RANGE. The current flowing in the test circuit of figure 6A shall not exceed 10 mA.

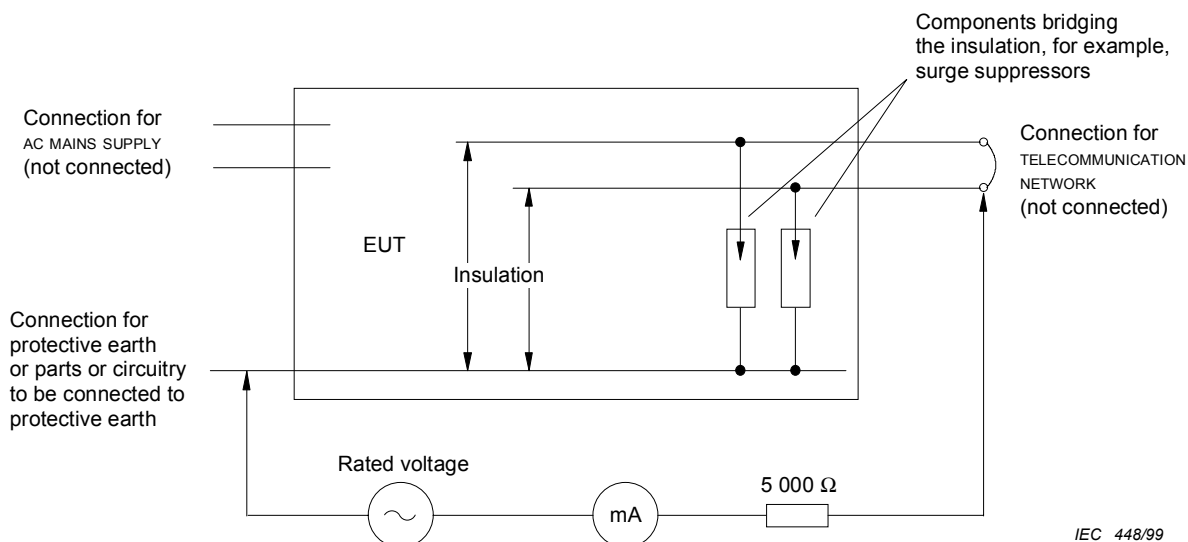

IEC 448/99

Figure 6A – Test for separation between a telecommunication network and earth

6.1.2.2 Exclusions

The requirements of 6.1.2.1 do not apply to any of the following:

- PERMANENTLY CONNECTED EQUIPMENT OR PLUGGABLE EQUIPMENT TYPE B;
- equipment that is intended to be installed by a SERVICE PERSON and has installation instructions that require the equipment to be connected to a socket-outlet with a protective earthing connection (see 6.1.1);
- equipment that has provision for a permanently connected PROTECTIVE EARTHING CONDUCTOR and is provided with instructions for the installation of that conductor.

NOTE In Finland, Norway and Sweden, the exclusions are applicable only for PERMANENTLY CONNECTED EQUIPMENT, PLUGGABLE EQUIPMENT TYPE B and equipment intended to be used in a RESTRICTED ACCESS LOCATION where equipotential bonding has been applied, for example, in a telecommunication centre, and which has provision for a permanently connected PROTECTIVE EARTHING CONDUCTOR and is provided with instructions for the installation of that conductor by a SERVICE PERSON.

6.2 Protection of equipment users from overvoltages on telecommunication networks

6.2.1 Separation requirements

Equipment shall provide adequate electrical separation between a TNV-1 CIRCUIT or a TNV-3 CIRCUIT and the following parts of the equipment.

- a) Unearthed conductive parts and non-conductive parts of the equipment expected to be held or touched during normal use (for example, a telephone handset or a keyboard).

- b) Parts and circuitry that can be touched by the test finger, figure 2A (see 2.1.1.1), except contacts of connectors that cannot be touched by the test probe, figure 2C (see 2.1.1.1).
- c) An SELV CIRCUIT, a TNV-2 CIRCUIT or a LIMITED CURRENT CIRCUIT provided for connection of other equipment. The requirement for separation applies whether or not this circuit is accessible.

These requirements do not apply where circuit analysis and equipment investigation indicate that safety is assured by other means, for example, between two circuits each of which has a permanent connection to protective earth.

Compliance is checked by the tests of 6.2.2. The requirements of 2.10 regarding the dimensions and construction of CLEARANCE, CREEPAGE DISTANCE and solid insulation do not apply for compliance with 6.2.1.

NOTE The requirements of 2.10 may apply for compliance with 2.2 and 2.3. See items 5) and 6) of table 2G.

6.2.2 Electric strength test procedure

Compliance with 6.2.1 is checked by the test of either 6.2.2.1 or 6.2.2.2.

NOTE In Australia, the tests of both 6.2.2.1 and 6.2.2.2 apply.

If a test is applied to a component (see 1.4.3), for example, a signal transformer, which is clearly intended to provide the separation required, the component shall not be bypassed by other components, mounting devices or wiring, unless these components or wiring also meet the separation requirements of 6.2.

For the tests, all conductors intended to be connected to the TELECOMMUNICATION NETWORK are connected together (see figure 6B), including any conductors required by the TELECOMMUNICATION NETWORK authority to be connected to earth. Similarly, all conductors intended to be connected to other equipment are connected together for testing related to 6.2.1 c).

Non-conductive parts are tested with metal foil in contact with the surface. Where adhesive metal foil is used, the adhesive shall be conductive.

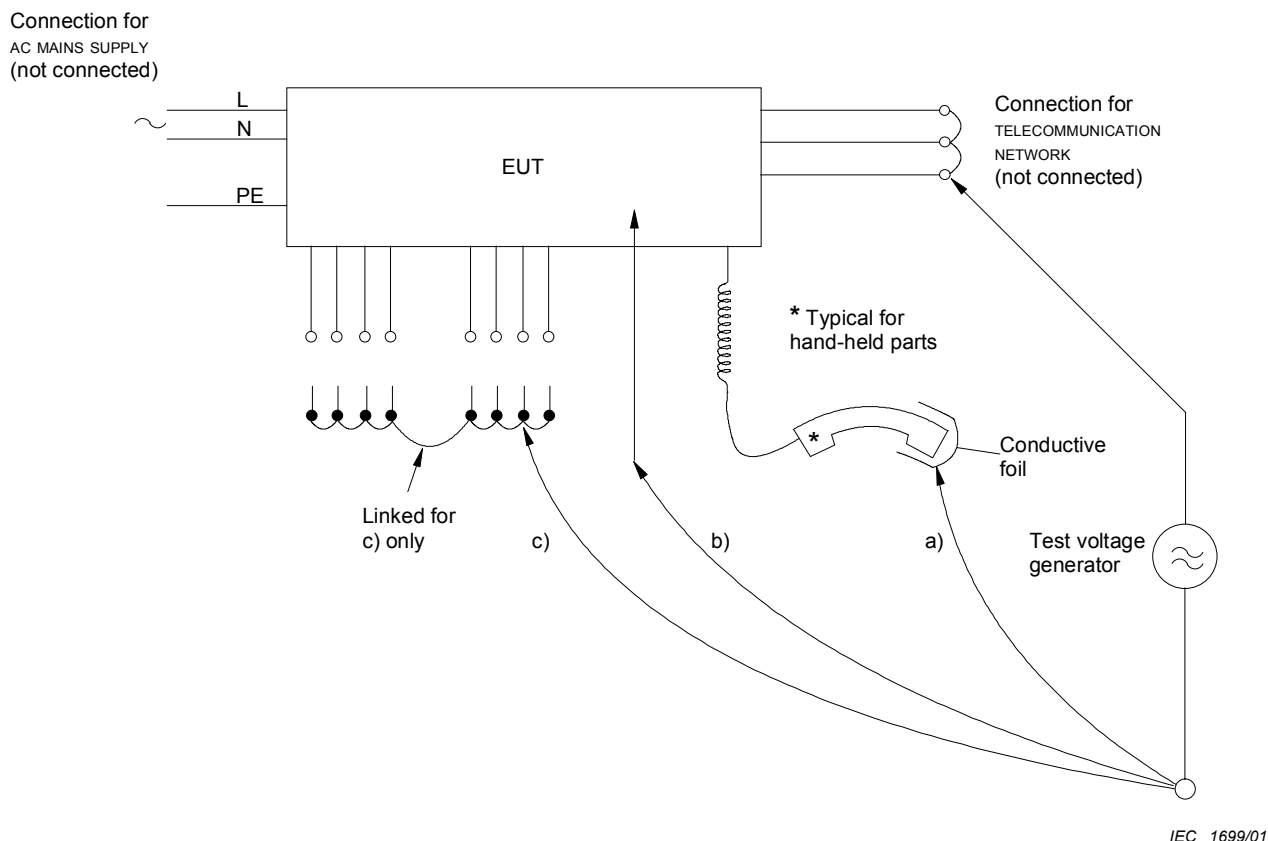

Figure 6B – Application points of test voltage

6.2.2.1 Impulse test

The electrical separation is subjected to 10 impulses of alternating polarity, using the impulse test generator of annex N for 10/700 μ s impulses. The interval between successive impulses is 60 s and the initial voltage, U_c , is:

- for 6.2.1 a): 2,5 kV; and
- for 6.2.1 b) and 6.2.1 c): 1,5 kV.

NOTE 1 The value of 2,5 kV for 6.2.1 a) has been chosen primarily to ensure the adequacy of the insulation concerned and it does not necessarily simulate likely overvoltages.

NOTE 2 In Australia, a value of $U_c = 7,0$ kV is used in 6.2.1 a).

6.2.2.2 Steady-state test

The electrical separation is subjected to an electric strength test according to 5.2.2.

The a.c. test voltage is:

- for 6.2.1 a): 1,5 kV; and
- for 6.2.1 b) and 6.2.1 c): 1,0 kV.

NOTE In Australia, a value of 3,0 kV is used in 6.2.1 a) for hand-held telephones and headsets and 2,5 kV for other equipment, to simulate lightning surges on typical rural and semi rural network lines. A value of 1,5 kV is used in 6.2.1 b) and c).

For 6.2.1 b) and 6.2.1 c), it is permitted to remove surge suppressors, provided that such devices pass the impulse test of 6.2.2.1 for 6.2.1 b) and 6.2.1 c) when tested as components outside the equipment. For 6.2.1 a), surge suppressors shall not be removed.

6.2.2.3 Compliance criteria

During the tests of 6.2.2.1 and 6.2.2.2, there shall be no breakdown of insulation.

Insulation breakdown is considered to have occurred when the current which flows as a result of the application of the test voltage rapidly increases in an uncontrolled manner, that is the insulation does not restrict the flow of current.

If a surge suppressor operates (or sparkover occurs within a gas discharge tube) during the test:

- for 6.2.1 a), such operation represents a failure; and*
- for 6.2.1 b) and 6.2.1 c), such operation is permitted during the impulse test; and*
- for 6.2.1 b) and 6.2.1 c), such operation during the electric strength test (by any surge suppressor left in place) represents a failure.*

For impulse tests, damage to insulation is verified in one of two ways, as follows:

- during the application of the impulses, by observation of oscillograms. Surge suppressor operation or breakdown through insulation is judged from the shape of an oscillogram.*
- after application of all the impulses, by an insulation resistance test. Disconnection of surge suppressors is permitted while insulation resistance is being measured. The test voltage is 500 V d.c. or, if surge suppressors are left in place, a d.c. test voltage that is 10 % less than the surge suppressor operating or striking voltage. The insulation resistance shall not be less than 2 M Ω .*

NOTE A description of procedures to judge whether a surge suppressor operation or breakdown of insulation has occurred, using oscillograms, is given in annex S.

6.3 Protection of the telecommunication wiring system from overheating

Equipment intended to provide power over the telecommunication wiring system to remote equipment shall limit the output current to a value that does not cause damage to the telecommunication wiring system, due to overheating, under any external load condition. The maximum continuous current from equipment shall not exceed a current limit that is suitable for the minimum wire gauge specified in the equipment installation instructions. The current limit is 1,3 A if such wiring is not specified.

NOTE 1 The overcurrent protective device may be a discrete device such as a fuse, or a circuit that performs that function.

NOTE 2 The minimum wire diameter normally used in telecommunication wiring is 0,4 mm, for which the maximum continuous current for a multipair cable is 1,3 A. This wiring is not usually controlled by the equipment installation instructions, since the wiring is often installed independent of the equipment installation.

NOTE 3 Further current limitation may be necessary for equipment intended for connection to networks which are subject to overvoltages, due to operating parameters for protective devices.

Compliance is checked as follows.

If current limiting is due to the inherent impedance of the power source, the output current into any resistive load, including a short circuit, is measured. The current limit shall not be exceeded after 60 s of test.

If current limiting is provided by an overcurrent protective device having a specified time/current characteristic:

- *the time/current characteristic shall show that a current equal to 110 % of the current limit will be interrupted within 60 min; and*

NOTE 4 Time/current characteristics of type gD and type gN fuses specified in IEC 60269-2-1 comply with the above limit. Type gD or type gN fuses rated 1 A, would meet the 1,3 A current limit.

- *the output current into any resistive load, including a short circuit, with the overcurrent protective device bypassed, measured after 60 s of test, shall not exceed $1\,000/U$, where U is the output voltage measured in accordance with 1.4.5 with all load circuits disconnected.*

If current limiting is provided by an overcurrent protective device that does not have a specified time/current characteristic:

- *the output current into any resistive load, including a short circuit, shall not exceed the current limit after 60 s of test; and*
- *the output current into any resistive load, including a short circuit, with the overcurrent protective device bypassed, measured after 60 s of test, shall not exceed $1\,000/U$, where U is the output voltage measured in accordance with 1.4.5 with all load circuits disconnected.*

7 Connection to cable distribution systems

If the equipment is to be connected to a CABLE DISTRIBUTION SYSTEM, the requirements of clause 7 apply in addition to the requirements of clauses 1 to 5 of this standard.

NOTE 1 It is assumed that adequate measures have been taken to reduce the likelihood that transient overvoltages presented to the equipment exceed the following values:

- 5 kV to power fed repeaters, see ITU-T Recommendation K.17;
- 4 kV to other equipment, see ITU-T Recommendation K.21;
- 10 kV for equipment to be connected only to an outdoor antenna.

In installations where overvoltages presented to the equipment may exceed these values, additional measures such as surge suppression may be necessary.

NOTE 2 Legal requirements may exist regarding the connection of information technology equipment to a CABLE DISTRIBUTION SYSTEM operated by a public network operator.

NOTE 3 The AC MAINS SUPPLY system, if used as a communication medium, is not a CABLE DISTRIBUTION SYSTEM (see 1.2.13.14) and clause 7 does not apply. For equipment to be connected to such systems, the other clauses of this standard will apply to coupling components, such as signal transformers and capacitors, connected between the mains and other circuitry. The requirements for DOUBLE INSULATION or REINFORCED INSULATION will generally apply. See also IEC 60664-1 for overvoltages to be expected at various points in the AC MAINS SUPPLY system.

NOTE 4 It is assumed that the cable shield will be earthed in accordance with the installation requirements of ITU-T Recommendation K.31.

7.1 Protection of cable distribution system service persons, and users of other equipment connected to the system, from hazardous voltages in the equipment

Circuitry intended to be directly connected to a CABLE DISTRIBUTION SYSTEM shall comply with the requirements for a TNV-1 CIRCUIT, a TNV-3 CIRCUIT or a HAZARDOUS VOLTAGE SECONDARY CIRCUIT, depending on the normal operating voltage.

Where protection of the CABLE DISTRIBUTION SYSTEM relies on protective earthing of the equipment, the installation instructions and other relevant literature shall state that the integrity of the protective earth must be ensured. (See also 1.7.2.)

Compliance is checked by inspection and by measurement.

NOTE For requirements in Finland, Norway and Sweden, see 6.1.2.1, note and 6.1.2.2 note. The term TELECOMMUNICATION NETWORK in 6.1.2 is replaced by CABLE DISTRIBUTION SYSTEM.

7.2 Protection of equipment users from overvoltages on the cable distribution system

The requirements and tests of 6.2 apply except that the term "TELECOMMUNICATION NETWORK" is replaced by "CABLE DISTRIBUTION SYSTEM" throughout 6.2. When applying 6.2 to CABLE DISTRIBUTION SYSTEMS, the separation requirements apply only to those circuit parts that are directly connected to the inner conductor (or conductors) of the coaxial cable; the separation requirements do not apply to those circuit parts that are directly connected to the outer screen or screens.

7.3 Insulation between primary circuits and cable distribution systems

7.3.1 General

Except as specified below, the insulation between the PRIMARY CIRCUIT and the terminal or lead provided for the connection of a CABLE DISTRIBUTION SYSTEM shall comply with:

- the voltage surge test of 7.3.2 for equipment intended to be connected to outdoor antennas; or
- the impulse test of 7.3.3 for equipment intended to be connected to other CABLE DISTRIBUTION SYSTEMS.

If an equipment is intended for connection to both an outdoor antenna and another CABLE DISTRIBUTION SYSTEM, it shall be tested according to both 7.3.2 and 7.3.3.

The above requirement does not apply to any of the following:

- equipment intended for indoor use only, provided with a built in (integral) antenna and not provided with a connection to a CABLE DISTRIBUTION SYSTEM;
- PERMANENTLY CONNECTED EQUIPMENT, or PLUGGABLE EQUIPMENT TYPE B, in which the circuit intended to be connected to the CABLE DISTRIBUTION SYSTEM is also connected to protective earth in accordance with 2.6.1 f);
- PLUGGABLE EQUIPMENT TYPE A, in which the circuit intended to be connected to the CABLE DISTRIBUTION SYSTEM is also connected to protective earth in accordance with 2.6.1 f); and either
 - is intended to be installed by a SERVICE PERSON and has installation instructions that require the equipment to be connected to a socket-outlet with a protective earthing connection; or
 - has provision for a permanently connected PROTECTIVE EARTHING CONDUCTOR, including instructions for the installation of that conductor.

Compliance is checked by inspection and if necessary by the voltage surge test of 7.3.2 or impulse test of 7.3.3.

NOTE CLEARANCES are determined by the requirements of 2.10.3 or annex G. It may be necessary to increase the CLEARANCES between PRIMARY CIRCUITS and SECONDARY CIRCUITS intended for connection to CABLE DISTRIBUTION SYSTEMS so that the circuits can comply with 7.3.2 or 7.3.3.

7.3.2 Voltage surge test

The test is applied between the supply circuit terminals and the main protective earthing terminal, if any, joined together, and the connection points for the CABLE DISTRIBUTION SYSTEM, excluding any earthed conductor, joined together. Fifty discharges are applied from the impulse test generator reference 3 of table N.1, at a maximum rate of 12 discharges per minute, with U_c equal to 10 kV. The "ON"/"OFF" switch, if provided, is in the "ON" position.

After the test, the insulation shall continue to comply with the electric strength test requirement of 5.2.2.

7.3.3 Impulse test

The test is applied between the supply circuit terminals and the main protective earthing terminal, if any, joined together, and the connection points for the CABLE DISTRIBUTION SYSTEM, excluding any earthed conductor, joined together. Ten impulses of alternating polarity are applied from the impulse test generator reference 1 of table N.1, with a 60 s interval between successive impulses, with U_c equal to

- 5 kV for power-fed repeaters;*
- 4 kV for all other terminal and network equipment.*

The "ON"/"OFF" switch, if provided, is in the "ON" position.

After the test, the insulation shall continue to comply with the electric strength test requirement of 5.2.2.

Annex A (normative)

Tests for resistance to heat and fire

It should be noted that toxic fumes may be given off during the tests. Where appropriate the tests should be carried out either under a ventilated hood or in a well-ventilated room, but free from draughts which could invalidate the tests.

A.1 Flammability test for fire enclosures of movable equipment having a total mass exceeding 18 kg and of stationary equipment (see 4.7.3.2)

A.1.1 Samples

Three samples, each consisting of either a complete FIRE ENCLOSURE or a section of the FIRE ENCLOSURE representing the thinnest significant wall thickness and including any ventilation opening, are tested.

A.1.2 Conditioning of samples

Prior to being tested, the samples are conditioned in a circulating air oven for a period of 7 days (168 h), at a uniform temperature 10 K higher than the maximum temperature reached by the material measured during the test of 4.5.1, or 70 °C, whichever is the higher, and then cooled to room temperature.

A.1.3 Mounting of samples

Samples are mounted as they would be in actual use. A layer of untreated surgical cotton is located 300 mm below the point of application of the test flame.

A.1.4 Test flame

The test flame according to IEC 60695-11-3 is used.

A.1.5 Test procedure

The test flame is applied to an inside surface of the sample, at a location judged to be likely to become ignited because of its proximity to a source of ignition. If a vertical part is involved, the flame is applied at an angle of approximately 20° from the vertical. If ventilation openings are involved, the flame is applied to an edge of an opening, otherwise to a solid surface. In all cases, the tip of the inner blue cone is to be in contact with the sample. The flame is applied for 5 s and removed for 5 s. This operation is repeated until the sample has been subjected to five applications of the test flame to the same location.

The test is repeated on the remaining two samples. If more than one part of the FIRE ENCLOSURE is near a source of ignition, each sample is tested with the flame applied to a different location.

A.1.6 Compliance criteria

During the test, the sample shall not release either flaming drops or particles capable of igniting the surgical cotton. The sample shall not continue to burn for more than 1 min after the fifth application of the test flame, and shall not be consumed completely.

A.2 Flammability test for fire enclosures of movable equipment having a total mass not exceeding 18 kg, and for material and components located inside fire enclosures (see 4.7.3.2 and 4.7.3.4)

A.2.1 Samples

Three samples are tested. For FIRE ENCLOSURES, each sample consists of either a complete FIRE ENCLOSURE or a section of the FIRE ENCLOSURE representing the thinnest significant wall thickness and including any ventilation opening. For material to be located within the FIRE ENCLOSURE, each sample of the material consists of one of the following:

- the complete part; or*
- a section of the part representing the thinnest significant wall thickness; or*
- a test plaque or bar of uniform thickness representing the thinnest significant section of the part.*

For components to be located within the FIRE ENCLOSURE, each sample is to be a complete component.

A.2.2 Conditioning of samples

Prior to being tested, the samples are conditioned in a circulating air oven for a period of 7 days (168 h), at a uniform temperature 10 K higher than the maximum temperature of the part measured during the test of 4.5.1, or 70 °C, whichever is the higher, and then cooled to room temperature.

A.2.3 Mounting of samples

Samples are mounted and oriented as they would be in actual use.

A.2.4 Test flame

The test flame according to IEC 60695-11-4 is used.

A.2.5 Test procedure

The test flame is applied to an inside surface of the sample at a point judged to be likely to become ignited because of its proximity to a source of ignition. For the evaluation of materials located within the FIRE ENCLOSURE, it is permitted to apply the test flame to an external surface of the sample. For the evaluation of components to be located within the FIRE ENCLOSURE, the test flame is applied directly to the component.

If a vertical part is involved, the flame is applied at an angle of approximately 20° from the vertical. If ventilation openings are involved, the flame is applied to an edge of an opening, otherwise to a solid surface. In all cases, the tip of the flame is to be in contact with the sample. The flame is applied for 30 s and removed for 60 s, then reapplied to the same location for 30 s.

The test is repeated on the remaining two samples. If any part being tested is near a source of ignition at more than one point, each sample is tested with the flame applied to a different point which is near a source of ignition.

A.2.6 Compliance criteria

During the test, the samples shall not continue to burn for more than 1 min after the second application of the test flame, and shall not be consumed completely.

A.2.7 Alternative test

As an alternative to the apparatus and procedure specified in A.2.4 and A.2.5, it is permitted to use the apparatus and procedure specified in IEC 60695-2-2:1991, clauses 4 and 8. The manner, duration and number of flame applications are as specified in A.2.5 and compliance is in accordance with A.2.6.

NOTE Compliance with the method of either A.2.4 and A.2.5 or of A.2.7 is acceptable; it is not required to comply with both methods.

A.3 Hot flaming oil test (see 4.6.2)

A.3.1 Mounting of samples

A sample of the complete finished bottom of the FIRE ENCLOSURE is securely supported in a horizontal position. Bleached cheesecloth of approximately 40 g/m² is placed in one layer over a shallow, flat-bottomed pan approximately 50 mm below the sample, and is of sufficient size to cover completely the pattern of openings in the sample, but not large enough to catch any of the oil that runs over the edge of the sample or otherwise does not pass through the openings.

NOTE Use of a metal screen or a wired-glass partition surrounding the test area is recommended.

A.3.2 Test procedure

A small metal ladle (preferably no more than 65 mm in diameter), with a pouring lip and a long handle whose longitudinal axis remains horizontal during pouring, is partially filled with 10 ml of a distillate fuel oil which is a medium volatile distillate having a mass per unit volume between 0,845 g/ml and 0,865 g/ml, a flash point between 43,5 °C and 93,5 °C and an average calorific value of 38 MJ/l. The ladle containing the oil is heated and the oil ignited and permitted to burn for 1 min, at which time all of the hot flaming oil is poured at the rate of approximately 1 ml/s in a steady stream onto the centre of the pattern of openings, from a position approximately 100 mm above the openings.

The test is repeated twice at 5 min intervals, using clean cheesecloth.

A.3.3 Compliance criterion

During these tests the cheesecloth shall not ignite.

Annex B (normative)

Motor tests under abnormal conditions

(see 4.7.2.2 and 5.3.2)

B.1 General requirements

Motors, other than d.c. motors in SECONDARY CIRCUITS, shall pass the tests of B.4 and B.5 and, where applicable, B.8, B.9 and B.10, except that the following motors are not required to pass the test of B.4:

- *motors which are used for air-handling only and where the air propelling component is directly coupled to the motor shaft; and*
- *shaded pole motors whose values of locked-rotor current and no-load current do not differ by more than 1 A and have a ratio of not more than 2/1.*

DC motors in SECONDARY CIRCUITS shall pass the tests of B.6, B.7 and B.10 except that motors which by their intrinsic operation normally operate under locked-rotor conditions, such as stepper motors, are not tested.

B.2 Test conditions

Unless otherwise specified in this annex, during the test the equipment is operated at RATED VOLTAGE, or at the upper voltage of the RATED VOLTAGE RANGE.

The tests are carried out either in the equipment or under simulated conditions on the bench. It is permitted to use separate samples for bench tests. Simulated conditions include:

- *any protection devices which would protect the motor in the complete equipment; and*
- *use of any mounting means which may serve as a heat sink to the motor frame.*

Temperatures of windings are measured as specified in 1.4.13. Where thermocouples are used they are applied to the surface of the motor windings. Temperatures are determined at the end of the test period where specified, otherwise when the temperature has stabilized, or at the instant of operation of fuses, THERMAL CUT-OUTS, motor protection devices and the like.

For totally enclosed, impedance-protected motors, the temperatures are measured by thermocouples applied to the motor case.

When motors without inherent thermal protection are tested under simulated conditions on the bench, the measured winding temperature is adjusted to take into account the ambient temperature in which the motor is normally located within the equipment as measured during the test of 4.5.1.

B.3 Maximum temperatures

For the tests in B.5, B.7, B.8 and B.9, the temperature limits, as specified in table B.1, shall not be exceeded for each class of insulating material.

**Table B.1 – Permitted temperature limits for motor windings
(except for running overload test)**

Maximum temperature °C					
Method of protection	Class A	Class E	Class B	Class F	Class H
Protection by inherent or external impedance	150	165	175	190	210
Protection by protective device which operates during the first hour	200	215	225	240	260
Protection by any protective device:					
– maximum after first hour	175	190	200	215	235
– arithmetic average during the 2nd hour and during the 72nd hour	150	165	175	190	210

The arithmetic average temperature is determined as follows:

The graph of temperature against time, see figure B.1, while the power to the motor is cycling on and off, is plotted for the period of test under consideration. The arithmetic average temperature (t_A) is determined by the formula:

$$t_A = \frac{t_{\max} + t_{\min}}{2}$$

where

t_{\max} is the average of the maxima;

t_{\min} is the average of the minima.

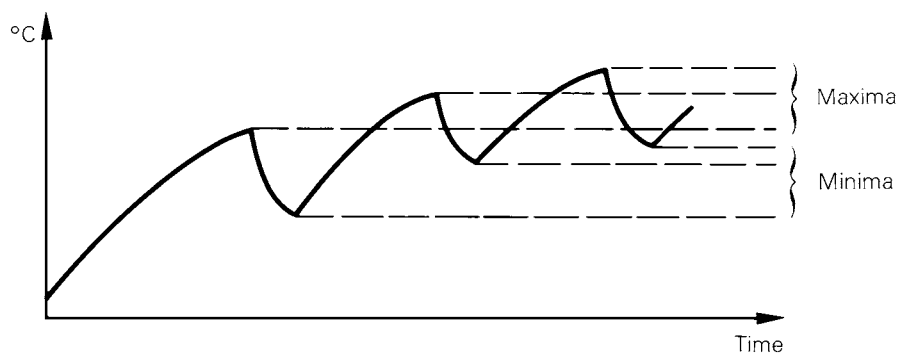

328/86

Figure B.1 – Determination of arithmetic average temperature

For the tests in B.4 and B.6, the temperature limits, as specified in table B.2, shall not be exceeded for each class of insulating material.

Table B.2 – Permitted temperature limits for running overload tests

Maximum temperature °C				
Class A	Class E	Class B	Class F	Class H
140	155	165	180	200

B.4 Running overload test

A running overload protection test is carried out by operating the motor under NORMAL LOAD. The load is then increased so that the current is increased in appropriate gradual steps, the motor supply voltage being maintained at its original value. When steady conditions are established, the load is again increased. The load is thus progressively increased in appropriate steps but without reaching locked-rotor condition (see clause B.5), until the overload protection device operates.

The motor winding temperatures are determined during each steady period and the maximum temperature recorded shall not exceed the values specified in table B.2.

B.5 Locked-rotor overload test

A locked-rotor test is carried out starting at room temperature.

The duration of the test is as follows:

- a motor protected by inherent or external impedance is operated with its rotor locked for 15 days except that testing may be discontinued when the windings of the motor, of either the open or totally enclosed type, reach a constant temperature, provided that the constant temperature is not more than that specified in 4.5.1 for the insulation system used;
- a motor with an automatic reset protection device is cycled with its rotor locked for 18 days;
- a motor with a manual reset protection device is cycled with its rotor locked for 60 cycles, the protection device being reset after each operation as soon as possible for it to remain closed, but after not less than 30 s;
- a motor with a non-resettable protection device is operated with its rotor locked until the device operates.

Temperatures are recorded at regular intervals during the first three days for a motor with inherent or external impedance protection or with an automatic reset protection device, or during the first ten cycles for a motor with a manual reset protection device, or at the time of operation of a non-resettable protection device.

The temperatures shall not exceed the values specified in table B.1.

During the test, protective devices shall operate reliably without breakdown of insulation to the motor frame or permanent damage to the motor, including excessive deterioration of the insulation.

Permanent damage to the motor includes:

- severe or prolonged smoking or flaming;*
- electrical or mechanical breakdown of any associated component part such as a capacitor or starting relay;*
- flaking, embrittlement or charring of insulation.*

Discoloration of the insulation is permitted but charring or embrittlement to the extent that insulation flakes off or material is removed when the winding is rubbed with the thumb is not permitted.

After the period specified for temperature measurement, the motor shall withstand the electric strength test in 5.2.2 after the insulation has cooled to room temperature and with test voltages reduced to 0,6 times the specified values. No further electric strength test is required.

NOTE Continuation of the test of an automatic reset protection device beyond 72 h, and of a manual reset protection device beyond 10 cycles, is for the purpose of demonstrating the capability of the device to make and break locked-rotor current for an extended period of time.

B.6 Running overload test for d.c. motors in secondary circuits

The running overload test is carried out only if a possibility of an overload occurring is determined by inspection or by review of the design. The test need not be carried out, for example, where electronic drive circuits maintain a substantially constant drive current.

The test is carried out by operating the motor under NORMAL LOAD. The load is then increased so that the current is increased in appropriate gradual steps, the motor supply voltage being maintained at its original value. When steady conditions are established the load is again increased. The load is thus progressively increased in appropriate steps until either the overload protection device operates or the winding becomes an open circuit.

The motor winding temperatures are determined during each steady period and the maximum temperature recorded shall not exceed the value in table B.2, except that, where difficulty is experienced in obtaining accurate temperature measurements, due to the small size or unconventional design of the motor, it is permitted to use the following test instead of temperature measurement.

During the running overload test, the motor is covered with a single layer of bleached cotton cheesecloth of approximately 40 g/m². There shall be no ignition of the cheesecloth during the test or at its conclusion.

Compliance with either method is acceptable; it is not necessary to comply with both methods.

B.7 Locked-rotor overload test for d.c. motors in secondary circuits

Motors shall pass the test in B.7.1, except that, where difficulty is experienced in obtaining accurate temperature measurements, due to the small size or unconventional design of the motor, the method of B.7.2 can be used instead. Compliance may be established by either method.

B.7.1 Test procedure

The motor is operated at the voltage used in its application and with its rotor locked for 7 h or until steady conditions are established, whichever is the longer. Temperatures shall not exceed the values specified in table B.1.

B.7.2 Alternative test procedure

The motor is placed on a wooden board which is covered with a single layer of wrapping tissue, and the motor in turn covered with a single layer of bleached cotton cheesecloth of approximately 40 g/m².

NOTE Wrapping tissue is defined in ISO 4046 as a soft and strong, lightweight wrapping paper of grammage generally between 12 g/m² and 30 g/m², primarily intended for protective packaging of delicate articles and for gift wrapping.

The motor is then operated at the voltage used in its application and with its rotor locked for 7 h or until steady conditions are established, whichever is the longer.

At the conclusion of the test there shall be no ignition of the wrapping tissue or cheesecloth.

B.7.3 Electric strength test

Following the test of B.7.1 or B.7.2, as applicable, if the motor voltage exceeds 42,4 V peak, or 60 V d.c., and after it has cooled to room temperature, the motor shall withstand the electric strength test in 5.2.2 but with test voltages reduced to 0,6 times the specified values.

B.8 Test for motors with capacitors

Motors having phase-shifting capacitors are tested under locked rotor conditions with the capacitor short-circuited or open-circuited (whichever is the more unfavourable).

The short-circuit test is not made if the capacitor is so designed that, upon failure, it will not remain short-circuited.

Temperatures shall not exceed the values specified in table B.1.

NOTE Locked rotor is specified because some motors may not start and variable results could be obtained.

B.9 Test for three-phase motors

Three-phase motors are tested under NORMAL LOAD, with one line conductor disconnected, unless circuit controls prevent the application of voltage to the motor with one or more supply conductors disconnected.

The effect of other loads and circuits within the equipment may necessitate that the motor be tested within the equipment and with each of the three line conductors disconnected one at a time.

Temperatures shall not exceed the values specified in table B.1.

B.10 Test for series motors

Series motors are operated at a voltage equal to 1,3 times the motor voltage rating for 1 min with the lowest possible load.

After the test, windings and connections shall not have worked loose and no hazard shall be present in the meaning of this standard.

Annex C (normative)

Transformers (see 1.5.4 and 5.3.3)

C.1 Overload test

If the tests in this clause are carried out under simulated conditions on the bench, these conditions shall include any protection device which would protect the transformer in the complete equipment.

Transformers for switch mode power supply units are tested in the complete power supply unit or in the complete equipment. Test loads are applied to the output of the power supply unit.

A linear transformer or a ferro-resonant transformer has each secondary winding loaded in turn, with any other secondaries loaded between zero and their specified maxima to result in the maximum heating effect.

The output of a switch mode power supply unit is loaded to result in the maximum heating effect in the transformer.

NOTE For examples of loading to give the maximum heating effect, see annex X.

Where an overload cannot occur or is unlikely to create a hazard, the above tests are not made.

Maximum temperatures of windings shall not exceed the values in table C.1 when measured as specified in 1.4.13, and determined as specified below:

- *with external overcurrent protection: at the moment of operation, for determination of the time until the overcurrent protection operates, it is permitted to refer to a data sheet of the overcurrent protection device showing the trip time versus the current characteristics;*
- *with an AUTOMATIC RESET THERMAL CUT-OUT: as shown in table C.1 and after 400 h;*
- *with a MANUAL RESET THERMAL CUT-OUT: at the moment of operation;*
- *for current-limiting transformers: after temperature has stabilized.*

Secondary windings which exceed the temperature limits but which become open circuit or otherwise require replacement of the transformer do not constitute a failure of this test, provided that no hazard is created in the meaning of this standard.

For compliance criteria see 5.3.8.1 and 5.3.8.2.

Table C.1 – Permitted temperature limits for transformer windings

Maximum temperature °C					
Protection method	Class A	Class E	Class B	Class F	Class H
Protection by inherent or external impedance	150	165	175	190	210
Protection by protective device which operates during the first hour	200	215	225	240	260
Protection by any protective device:					
– maximum after first hour	175	190	200	215	235
– arithmetic average during the 2nd hour and during the 72nd hour	150	165	175	190	210

The arithmetic average temperature is determined as follows:

The graph of temperature against time (see figure C.1), while the power to the transformer is cycling on and off, is plotted for the period of test under consideration. The arithmetic average temperature (t_A) is determined by the formula:

$$t_A = \frac{t_{\max} + t_{\min}}{2}$$

where

t_{\max} is the average of the maxima;

t_{\min} is the average of the minima.

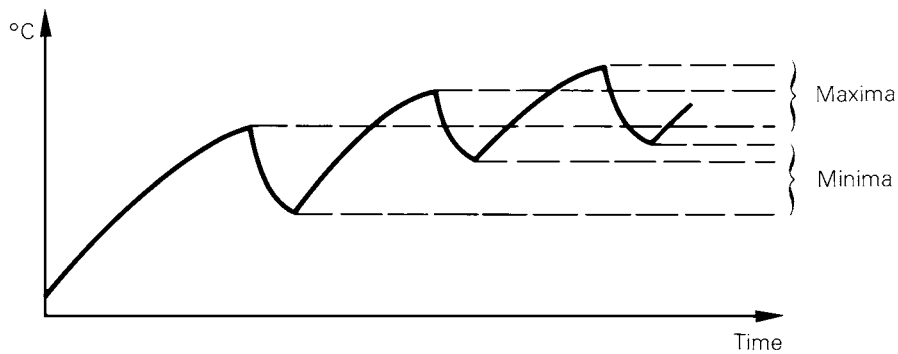

Figure C.1 – Determination of arithmetic average temperature

C.2 Insulation

Insulation in transformers shall comply with the following requirements.

Windings and conductive parts of transformers shall be treated as parts of the circuits to which they are connected, if any. The insulation between them shall comply with the relevant requirements of 2.10 and pass the relevant tests of 5.2, according to the application of the insulation in the equipment (see 2.9.3).

Precautions shall be taken to prevent the reduction below the required minimum values of CLEARANCES and CREEPAGE DISTANCE that provide BASIC INSULATION, SUPPLEMENTARY INSULATION or REINFORCED INSULATION by:

- *displacement of windings or their turns;*
- *displacement of internal wiring or wires for external connections;*
- *undue displacement of parts of windings or internal wiring, in the event of rupture of wires adjacent to connections or loosening of the connections;*
- *bridging of insulation by wires, screws, washers and the like should they loosen or become free.*

It is not expected that two independent fixings will loosen at the same time.

All windings shall have the end turns retained by positive means.

Compliance is checked by inspection, measurement, and if necessary, by the following tests.

If the transformer is fitted with a screen for protective earthing purposes that is separated from the primary winding connected to a HAZARDOUS VOLTAGE circuit by BASIC INSULATION only, the screen shall comply with one of the following:

- *meet the requirements of 2.6.3.3;*
- *meet the requirements of 2.6.3.4 between the earthed screen and the main protective earthing terminal of the equipment;*
- *pass a test simulating breakdown of BASIC INSULATION between the screen and the associated primary winding. The transformer shall be protected by any protective device used in the end application. The protective earthing path and the screen shall not be damaged.*

If tests are carried out, a specially prepared sample transformer having an extra lead-out wire from the free end of the screen is used to ensure that the current during the test passes through the screen.

No electric strength test applies to insulation between any winding and the core or screen, provided that the core or screen is totally enclosed or encapsulated and there is no electrical connection to the core or screen. However, the tests between windings which have terminations continue to apply.

NOTE Examples of acceptable forms of construction are the following (there are other acceptable forms of construction):

- windings isolated from each other by placing them on separate limbs of the core, with or without spools;
- windings on a single spool with a partition wall, where either the spool and partition wall are pressed or moulded in one piece, or a pushed-on partition wall has an intermediate sheath or covering over the joint between the spool and the partition wall;
- concentric windings on a spool of insulating material without flanges, or on insulation applied in thin sheet form to the transformer core;
- insulation is provided between windings consisting of sheet insulation extending beyond the end turns of each layer;
- concentric windings, separated by an earthed conductive screen which consists of metal foil extending the full width of the windings, with suitable insulation between each winding and the screen. The conductive screen and its lead-out wire have a cross section sufficient to ensure that on breakdown of the insulation an overload device will open the circuit before the screen is destroyed. The overload device may be a part of the transformer.

Annex D (normative)

Measuring instruments for touch-current tests (see 5.1.4)

D.1 Measuring instrument

The measuring instrument of figure D.1 is from IEC 60990, figure 4.

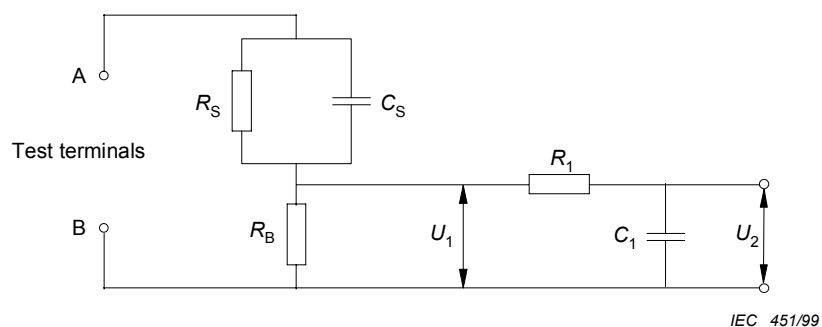

R_S	1 500 Ω	
R_B	500 Ω	
R_1	10 k Ω	
C_S	0,22 μF	
C_1	0,022 μF	
Voltmeter or oscilloscope (r.m.s. or peak reading)	Input resistance:	>1 M Ω
	Input capacitance:	<200 pF
	Frequency range:	15 Hz up to 1 MHz (appropriate for the highest frequency of interest, see 1.4.7)

Figure D.1 – Measuring instrument

The measuring instrument is calibrated by comparing the frequency factor of U_2 with the solid line in figure F.2 of IEC 60990 at various frequencies. A calibration curve is constructed showing the deviation of U_2 from the ideal curve as a function of frequency.

D.2 Alternative measuring instrument

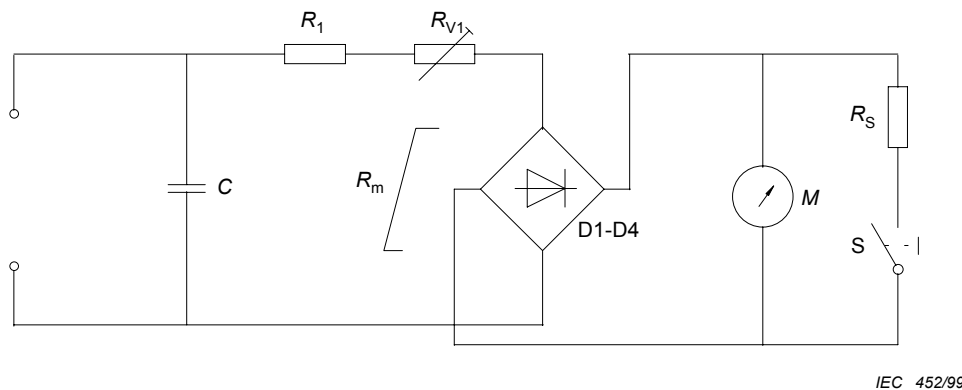

M	0 mA – 1 mA moving coil movement
$R_1 + R_{V1} + R_m$ at 0,5 mA d.c. =	1 500 $\Omega \pm 1\%$ with $C = 150 \text{ nF} \pm 1\%$ or 2 000 $\Omega \pm 1\%$ with $C = 112 \text{ nF} \pm 1\%$
D1-D4	Rectifier
R_s	Non-inductive shunt for $\times 10$ range
S	Sensitivity button (press for maximum sensitivity)

Figure D.2 – Alternative measuring instrument

The instrument comprises a rectifier/moving coil meter with additional series resistance, the two being shunted by a capacitor, as shown in figure D.2. The effect of the capacitor is to reduce the sensitivity to harmonics and other frequencies above the power frequency. The instrument should also include a $\times 10$ range obtained by shunting the meter coil by a non-inductive resistor. It is also permitted to include overcurrent protection, provided that the method used does not affect the basic characteristics of the instrument.

R_{V1} is adjusted for the desired value of total resistance at 0,5 mA d.c.

The meter is calibrated at the following calibration points on the maximum sensitivity range at 50 Hz to 60 Hz sinusoidal:

0,25 mA, 0,5 mA, 0,75 mA.

The following response is checked at the 0,5 mA calibration point:

Sensitivity at 5 kHz sinusoidal: 3,6 mA $\pm 5\%$.

Annex E (normative)

Temperature rise of a winding (see 1.4.13)

The value of the temperature rise of a winding is calculated from the formula:

for a copper winding
$$\Delta t = \frac{R_2 - R_1}{R_1} (234,5 + t_1) - (t_2 - t_1)$$

for an aluminium winding
$$\Delta t = \frac{R_2 - R_1}{R_1} (225 + t_1) - (t_2 - t_1)$$

where

Δt *is the temperature rise, in kelvins;*

R_1 *is the resistance of the winding at the beginning of the test, in ohms;*

R_2 *is the resistance of the winding at the end of the test, in ohms;*

t_1 *is the room temperature at the beginning of the test, in degrees Celsius;*

t_2 *is the room temperature at the end of the test, in degrees Celsius.*

At the beginning of the test, the windings are at room temperature.

It is recommended that the resistance of windings at the end of the test be determined by taking resistance measurements as soon as possible after switching off, and then at short intervals so that a curve of resistance against time can be plotted for ascertaining the resistance at the instant of switching off.

For comparison of winding temperatures determined by the resistance method of this annex with the temperature limits of table 4A, 25 °C is to be added to the calculated temperature rise.

Annex F (normative)

Measurement of clearances and creepage distances (see 2.10)

The methods of measuring CLEARANCES and CREEPAGE DISTANCES which are specified in the following figures are used in interpreting the requirements of this standard.

In the following figures, the value of X is given in table F.1. Where the distance shown is less than X , the depth of the gap or groove is disregarded when measuring a CREEPAGE DISTANCE.

Table F.1 is valid only if the required minimum CLEARANCE is 3 mm or more. If the required minimum CLEARANCE is less than 3 mm, the value of X is the lesser of:

- the relevant value in table F.1; or
- one third of the required minimum CLEARANCE.

Table F.1 – Value of X

Pollution degree (see 2.10.1)	X mm
1	0,25
2	1,0
3	1,5

In the following figures, CLEARANCES and CREEPAGE DISTANCES are shown as follows:

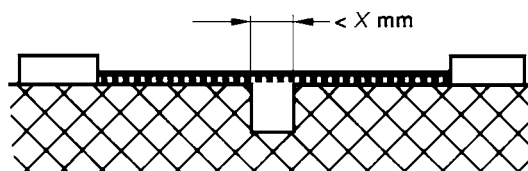

Condition: Path under consideration includes a parallel or converging-sided groove of any depth with width less than X mm.

Rule: CLEARANCE and CREEPAGE DISTANCE are measured directly across the groove.

Figure F.1 – Narrow groove

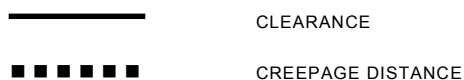

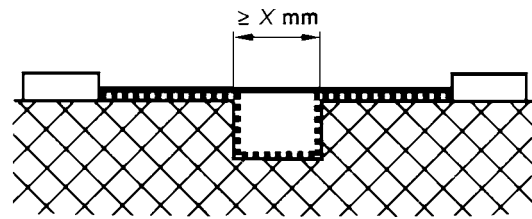

Condition: Path under consideration includes a parallel-sided groove of any depth, and equal to or more than X mm wide.

Rule: CLEARANCE is the "line of sight" distance. CREEPAGE DISTANCE path follows the contour of the groove.

Figure F.2 - Wide groove

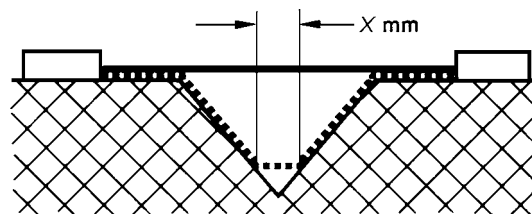

Condition: Path under consideration includes a V-shaped groove with internal angle of less than 80° and a width greater than X mm.

Rule: CLEARANCE is "line of sight" distance. CREEPAGE DISTANCE path follows the contour of the groove but "short circuits" the bottom of the groove by a link X mm long.

Figure F.3 - V-shaped groove

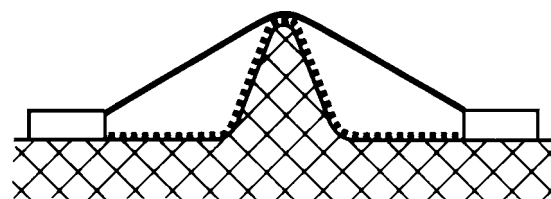

Condition: Path under consideration includes a rib.

Rule: CLEARANCE is the shortest direct air path over the top of the rib. CREEPAGE DISTANCE path follows the contour of the rib.

Figure F.4 - Rib

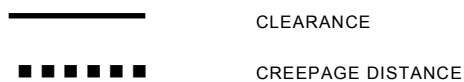

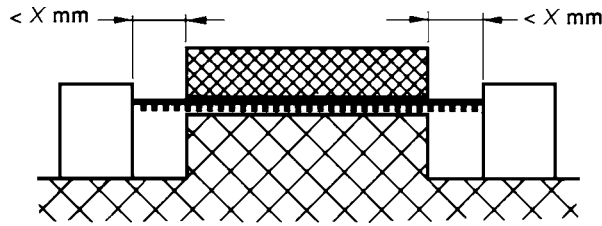

Condition: Path under consideration includes an uncemented joint with grooves less than X mm wide on either side.

Rule: CLEARANCE and CREEPAGE DISTANCE path is the "line of sight" distance shown.

Figure F.5 – Uncemented joint with narrow groove

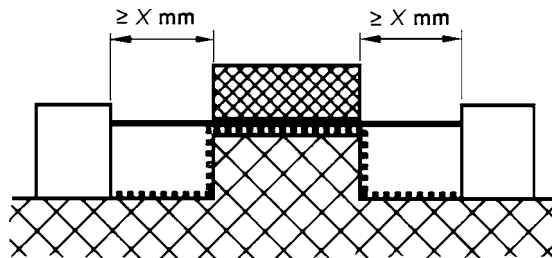

Condition: Path under consideration includes an uncemented joint with a groove equal to or more than X mm wide each side.

Rule: CLEARANCE is the "line of sight" distance. CREEPAGE DISTANCE path follows the contour of the groove.

Figure F.6 – Uncemented joint with wide groove

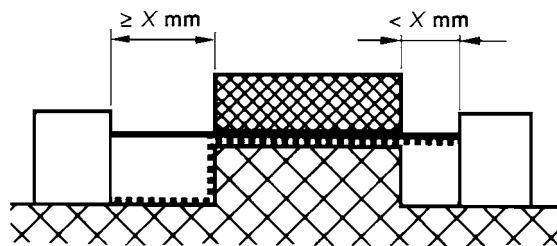

Condition: Path under consideration includes an uncemented joint with a groove on one side less than X mm wide and a groove on the other equal to or more than X mm wide.

Rule: CLEARANCE and CREEPAGE DISTANCE path are as shown.

Figure F.7 – Uncemented joint with narrow and wide grooves

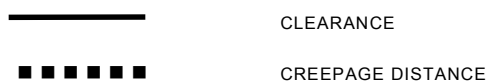

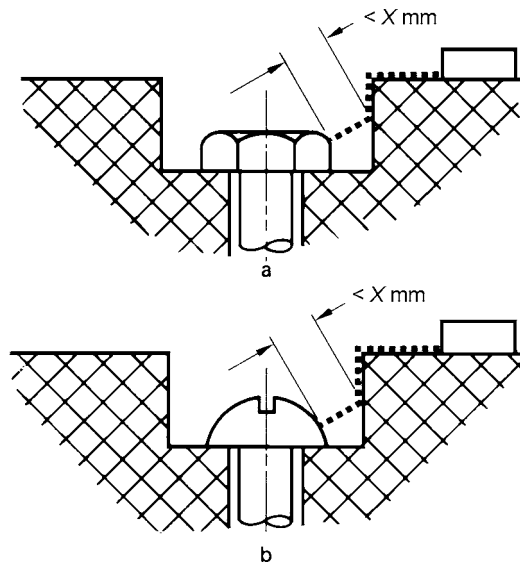

Gap between head of screw and wall of recess too narrow to be taken into account.

Figure F.8 – Narrow recess

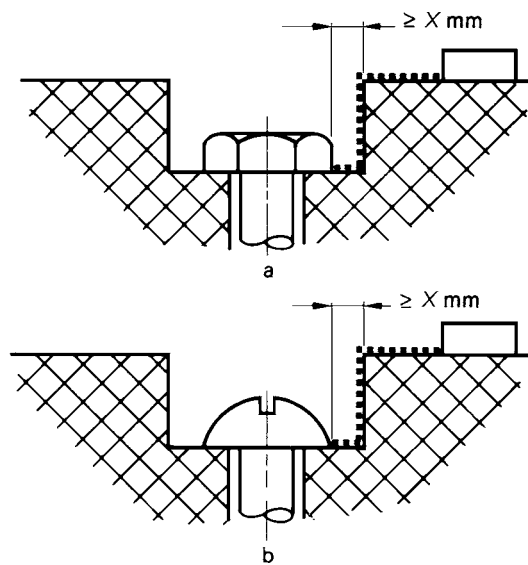

Gap between head of screw and wall of recess wide enough to be taken into account.

Figure F.9 – Wide recess



CREEPAGE DISTANCE

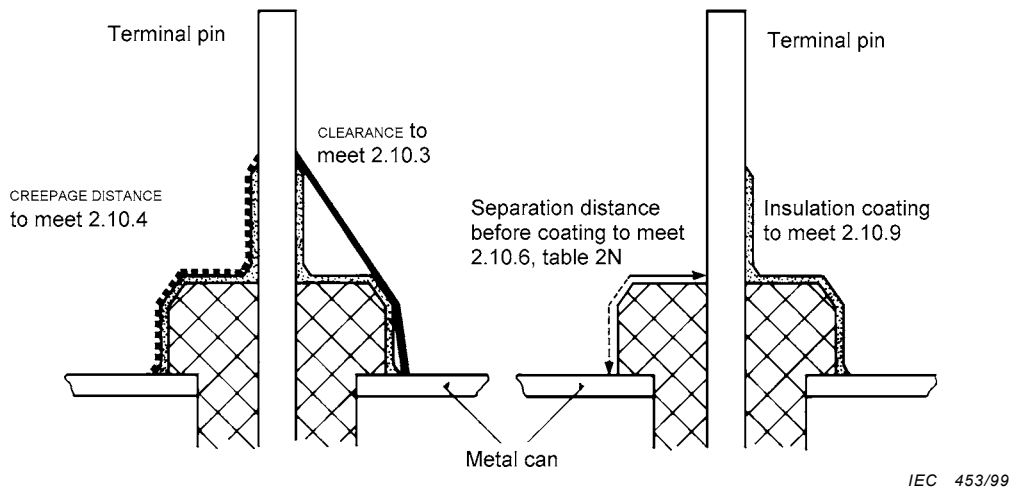

Figure F.10 – Coating around terminals

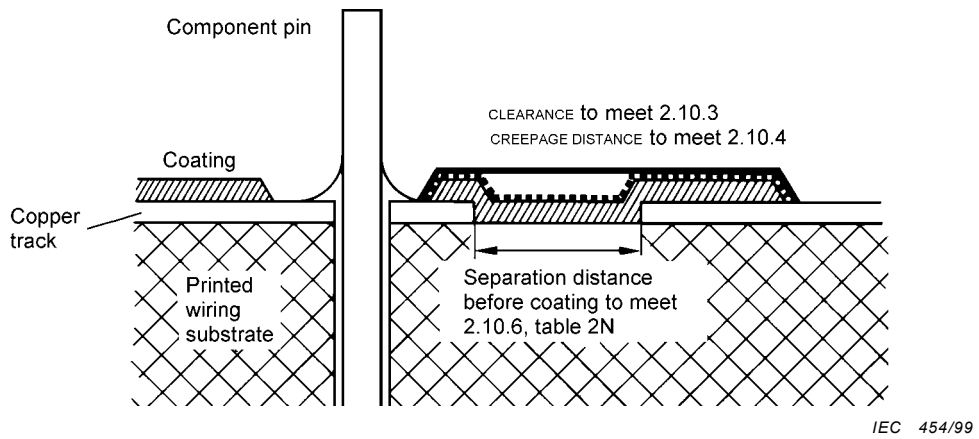
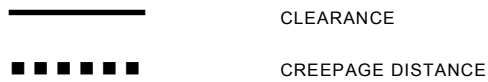
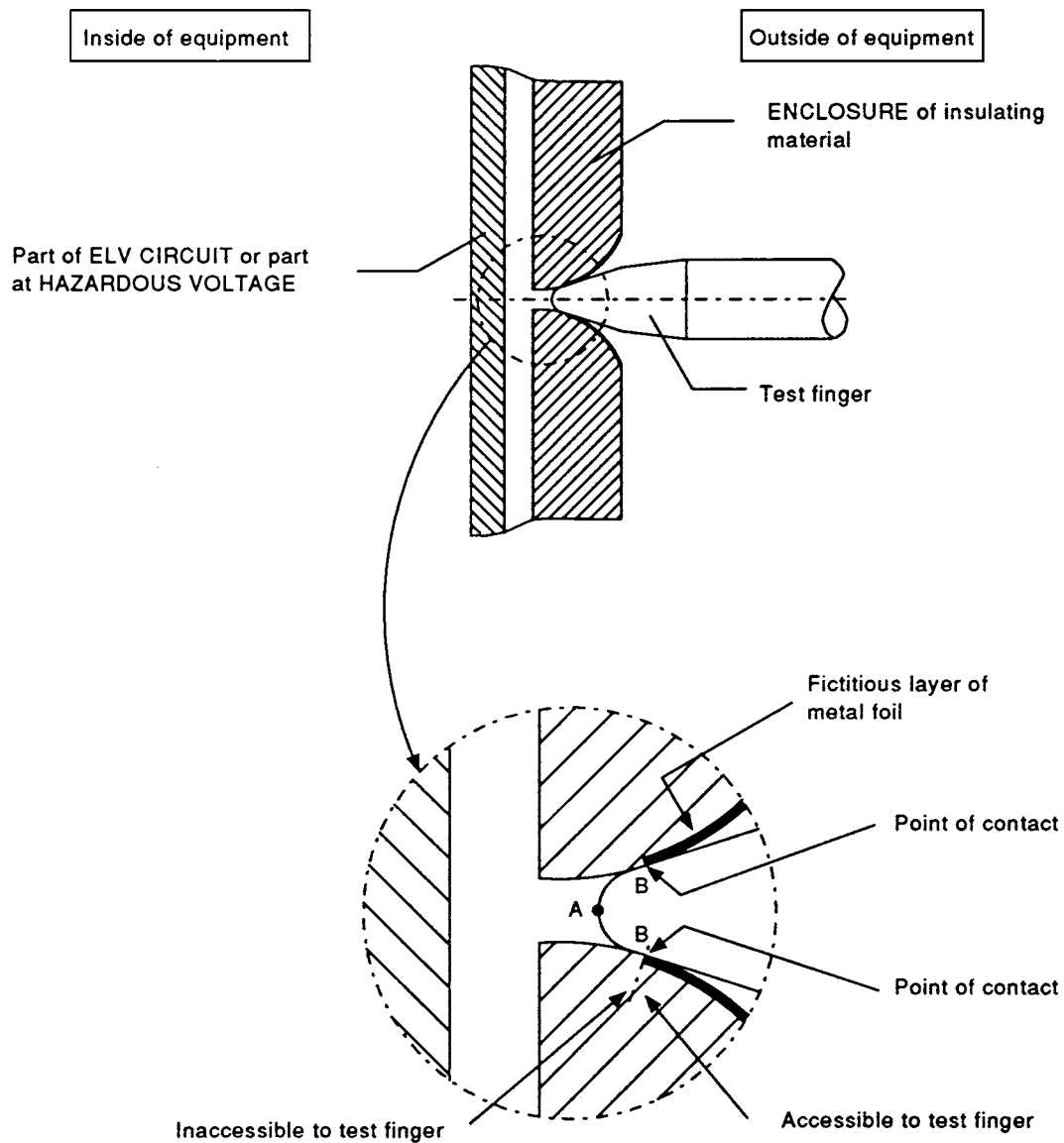

Figure F.11 – Coating over printed wiring





IEC 640193

Point A is used for determining the air gap to a part at a voltage exceeding 1 000 V a.c. or 1 500 V d.c. (see 2.1.1.1).

Point B is used for measurements of CLEARANCE and CREEPAGE DISTANCE from the outside of an ENCLOSURE of insulating material to a part inside the ENCLOSURE (see 2.10.3.1 and 2.10.4).

Figure F.12 – Example of measurements in an enclosure of insulating material

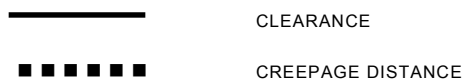

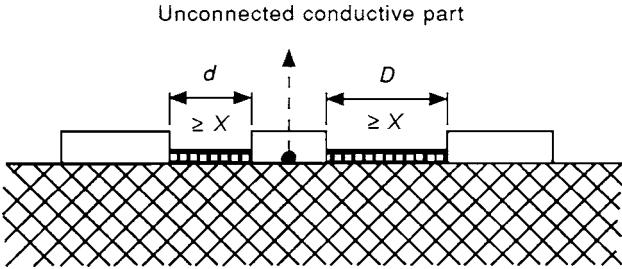

Condition: Insulation distance with intervening, unconnected conductive part.

Rule: CLEARANCE is the distance $d + D$.
CREEPAGE DISTANCE is also $d + D$.
Where the value of d or D is smaller than X , it shall be considered as zero.

Figure F.13 – Intervening, unconnected conductive part



Annex G (normative)

Alternative method for determining minimum clearances

This annex contains the alternative method for determining minimum CLEARANCES referred to in 2.10.3.

G.1 Summary of the procedure for determining minimum clearances

NOTE The minimum clearances for FUNCTIONAL INSULATION, BASIC INSULATION, SUPPLEMENTARY INSULATION and REINFORCED INSULATION, whether in a PRIMARY CIRCUIT or another circuit, depend on the REQUIRED WITHSTAND VOLTAGE. The REQUIRED WITHSTAND VOLTAGE depends in turn on the combined effect of the normal operating voltage (including repetitive peaks due to internal circuitry such as switch mode power supplies) and non-repetitive overvoltages due to external transients.

To determine the minimum value for each required CLEARANCE, the following steps shall be used:

1. Measure the PEAK WORKING VOLTAGE across the CLEARANCE in question.
2. If the equipment is mains operated:
 - determine the MAINS TRANSIENT VOLTAGE (G.2); and
 - for equipment to be connected to an AC MAINS SUPPLY, calculate the peak value of the nominal AC MAINS SUPPLY voltage.
3. Use the rules in item a) of clause G.4 and the above voltage values to determine the REQUIRED WITHSTAND VOLTAGE for mains transients and internal transients. In the absence of transients coming from a TELECOMMUNICATION NETWORK, go to step 7.
4. If the equipment is to be connected to a TELECOMMUNICATION NETWORK, determine the TELECOMMUNICATION NETWORK TRANSIENT VOLTAGE (clause G.3).
5. Use the TELECOMMUNICATION NETWORK TRANSIENT VOLTAGE and the rules in item b) of clause G.4 to determine the REQUIRED WITHSTAND VOLTAGE for TELECOMMUNICATION NETWORK transients. In the absence of mains and internal transients, go to step 7.
6. Use the rules in item c) of clause G.4 to determine the total REQUIRED WITHSTAND VOLTAGE.
7. Use the REQUIRED WITHSTAND VOLTAGE to determine the minimum CLEARANCE (G.6).

NOTE The effect of transients from a CABLE DISTRIBUTION SYSTEM is not taken into account when determining CLEARANCES (however, see 7.3.1).

G.2 Determination of mains transient voltage

G.2.1 AC mains supply

For equipment to be supplied from the AC MAINS SUPPLY, the value of the MAINS TRANSIENT VOLTAGE depends on the Overvoltage Category and the nominal value of the AC MAINS SUPPLY voltage. In general, CLEARANCES in equipment intended to be connected to the AC MAINS SUPPLY shall be designed for a MAINS TRANSIENT VOLTAGE in Overvoltage Category II.

Equipment that is part of the building power installation, or that may be subject to transient overvoltages exceeding those for Overvoltage Category II, shall be designed for Overvoltage Category III or IV, unless additional protection is to be provided external to the equipment. In this case, the installation instructions shall state the need for such external protection.

It should be noted that annex G only provides a method of determining minimum CLEARANCES for Overvoltage Categories III and IV. Other aspects of design for Overvoltage Categories III and IV must be considered, for example, requirements for solid insulation and for electric strength testing (see IEC 60664-1) and appropriate rating of components to withstand the MAINS TRANSIENT VOLTAGES given in table G.1.

The applicable value of the MAINS TRANSIENT VOLTAGE shall be determined from the Overvoltage Category and the nominal AC MAINS SUPPLY voltage using table G.1.

Table G.1 – Mains transient voltages

Nominal AC MAINS SUPPLY voltage line-to-neutral up to and including V r.m.s.	MAINS TRANSIENT VOLTAGE V_{peak}			
	Overvoltage category			
	I	II	III	IV
50	330	500	800	1 500
100	500	800	1 500	2 500
150 ¹⁾	800	1 500	2 500	4 000
300 ²⁾	1 500	2 500	4 000	6 000
600 ³⁾	2 500	4 000	6 000	8 000
1) Including 120/208 or 120/240 V. 2) Including 230/400 or 277/480 V. 3) Including 400/690 V.				

NOTE 1 In Norway, due to the IT power distribution system used (see figure V.7), the AC MAINS SUPPLY voltage is considered to be equal to the line-to-line voltage, and will remain 230 V in case of a single earth fault.

NOTE 2 In Japan, the value of the MAINS TRANSIENT VOLTAGES for the nominal AC MAINS SUPPLY voltage of 100 V is determined from columns applicable to the nominal AC MAINS SUPPLY voltage of 150 V.

G.2.2 DC mains supply

For equipment to be supplied from a DC MAINS SUPPLY that is connected to protective earth and is entirely within a single building, the MAINS TRANSIENT VOLTAGE is considered to be zero.

NOTE The connection to protective earth can be at the source of the DC MAINS SUPPLY or at the equipment location, or both (see ITU-T Recommendation K.27).

For equipment to be supplied from a DC MAINS SUPPLY that is not connected to protective earth, the value of the MAINS TRANSIENT VOLTAGE in the DC MAINS SUPPLY is the same as the MAINS TRANSIENT VOLTAGE in the PRIMARY CIRCUIT from which it is derived.

G.3 Determination of telecommunication network transient voltage

If the TELECOMMUNICATION NETWORK TRANSIENT VOLTAGE is not known for the TELECOMMUNICATION NETWORK in question, it shall be taken as:

- 1 500 V_{peak} if the circuit connected to the TELECOMMUNICATION NETWORK is a TNV-1 CIRCUIT or a TNV-3 CIRCUIT; and
- 800 V_{peak} if the circuit connected to the TELECOMMUNICATION NETWORK is an SELV CIRCUIT or a TNV-2 CIRCUIT.

G.4 Determination of required withstand voltage

a) Mains and internal transients

- PRIMARY CIRCUIT receiving the unattenuated mains transient:

In such a PRIMARY CIRCUIT, the effect of transients coming from a TELECOMMUNICATION NETWORK is ignored, and the following rules shall be applied:

Rule 1) If the PEAK WORKING VOLTAGE, U_{pw} , is less than the peak value of the nominal AC MAINS SUPPLY voltage, the REQUIRED WITHSTAND VOLTAGE is the MAINS TRANSIENT VOLTAGE determined in clause G.2;

$$U_{\text{required withstand}} = U_{\text{mains transient}}$$

Rule 2) If the PEAK WORKING VOLTAGE, U_{pw} , is greater than the peak value of the nominal AC MAINS SUPPLY voltage, the REQUIRED WITHSTAND VOLTAGE is the MAINS TRANSIENT VOLTAGE determined in clause G.2, plus the difference between the PEAK WORKING VOLTAGE and the peak value of the nominal AC MAINS SUPPLY voltage.

$$U_{\text{required withstand}} = U_{\text{mains transient}} + U_{\text{pw}} - U_{\text{mains peak}}$$

- SECONDARY CIRCUIT whose PRIMARY CIRCUIT receives the unattenuated mains transient:

In such a SECONDARY CIRCUIT, the REQUIRED WITHSTAND VOLTAGE shall be determined as follows, ignoring the effect of transients coming from TELECOMMUNICATION NETWORKS.

The above rules 1) and 2) are applied, with the MAINS TRANSIENT VOLTAGE determined in clause G.2 replaced by a voltage that is one step smaller in the following list:

330, 500, 800, 1 500, 2 500, 4 000, 6 000 and 8 000 V_{peak} .

However, this reduction is not permitted for a floating SECONDARY CIRCUIT unless it is in equipment with a main protective earthing terminal and is separated from its PRIMARY CIRCUIT by an earthed metal screen, connected to protective earth in accordance with 2.6.

Alternatively, the above rules 1) and 2) are applied but the voltage determined by measurement, see item a) of clause G.5, is taken as the MAINS TRANSIENT VOLTAGE.

- PRIMARY and SECONDARY CIRCUITS not receiving the unattenuated mains transient:

In such PRIMARY or SECONDARY CIRCUITS, the REQUIRED WITHSTAND VOLTAGE, ignoring the effect of transients coming from any TELECOMMUNICATION NETWORK, is determined as follows. The above rules 1) and 2) are applied, but a voltage determined by measurement, see item a) of clause G.5, shall be taken as the MAINS TRANSIENT VOLTAGE.

- SECONDARY CIRCUIT supplied by a d.c. source having capacitive filtering:

In any earthed SECONDARY CIRCUIT supplied by a d.c. source with capacitive filtering, the REQUIRED WITHSTAND VOLTAGE shall be taken as equal to the DC VOLTAGE.

b) *TELECOMMUNICATION NETWORK transients*

If transients only from a TELECOMMUNICATION NETWORK are involved, the REQUIRED WITHSTAND VOLTAGE is the TELECOMMUNICATION NETWORK TRANSIENT VOLTAGE determined in clause G.3, unless a lower level is measured when tested according to item b) of clause G.5.

c) *Combination of transients*

If both transients a) and b) are involved, the REQUIRED WITHSTAND VOLTAGE is the larger of the two voltages. The two values shall not be added together.

d) *Transients from CABLE DISTRIBUTION SYSTEMS*

The effect of transients from CABLE DISTRIBUTION SYSTEMS is not taken into account when determining REQUIRED WITHSTAND VOLTAGE.

G.5 Measurement of transient voltage levels

The following tests are conducted only where it is required to determine whether or not transient voltage across the CLEARANCE in any circuit is lower than normal (for example, due to the effect of a filter in the equipment). The transient voltage across the CLEARANCE is measured using the following test procedure, and the CLEARANCE shall be based on the measured value.

During the tests, the equipment is connected to its separate power supply unit, if any, but is not connected to the mains, nor to any TELECOMMUNICATION NETWORKS, and any surge suppressors in PRIMARY CIRCUITS are disconnected.

A voltage measuring device is connected across the CLEARANCE in question.

a) *Transients due to MAINS TRANSIENT VOLTAGES on the AC MAINS SUPPLY*

To measure the reduced level of transient voltages across a CLEARANCE due to MAINS TRANSIENT VOLTAGES on the AC MAINS SUPPLY, the impulse test generator reference 2 of table N.1 is used to generate 1,2/50 μ s impulses. U_c is equal to the MAINS TRANSIENT VOLTAGE determined in clause G.2.

Three to six impulses of alternating polarity, with intervals of at least 1 s between impulses, are applied between each of the following points where relevant:

- *line-to-line;*
- *all line conductors conductively joined together and neutral;*
- *all line conductors conductively joined together and protective earth;*
- *neutral and protective earth.*

b) *Transients due to TELECOMMUNICATION NETWORK TRANSIENT VOLTAGES*

To measure the reduced level of transient voltages across a CLEARANCE due to TELECOMMUNICATION NETWORK TRANSIENT VOLTAGES, the impulse test generator reference 1 of table N.1 is used to generate 10/700 μ s impulses. U_c is equal to the TELECOMMUNICATION NETWORK TRANSIENT VOLTAGE determined in clause G.3.

Three to six impulses of alternating polarity, with intervals of at least 1 s between impulses, are applied between each of the following TELECOMMUNICATION NETWORK connection points of a single interface type:

- *each pair of terminals (for example, A and B or tip and ring) in an interface;*
- *all terminals of a single interface type joined together and earth.*

Only one of a set of identical circuits is tested.

G.6 Determination of minimum clearances

For equipment to be operated up to 2 000 m above sea level, each CLEARANCE shall comply with the minimum dimensions given in table G.2, using the value of REQUIRED WITHSTAND VOLTAGE determined according to clause G.4.

For equipment to be operated at more than 2 000 m above sea level, the multiplication factors of table A.2 of IEC 60664-1:1992 shall be used in addition to table G.2. Interpolation of the table A.2 values is permitted.

Except as required by 2.8.7.1, the specified CLEARANCES are not applicable to the air gap between the contacts of THERMOSTATS, THERMAL CUT-OUTS, overload protection devices, switches of microgap construction and similar components where the air gap varies with the contacts.

NOTE For air gaps between contacts of disconnect devices, see 3.4.2. For air gaps between the contacts of interlock switches, see 2.8.7.1.

The specified CLEARANCES are subject to the following minimum values:

- 10 mm for an air gap serving as REINFORCED INSULATION between a part at HAZARDOUS VOLTAGE and an accessible conductive part of the ENCLOSURE of floor-standing equipment or of the non-vertical top surface of desk-top equipment;
- 2 mm for an air gap serving as BASIC INSULATION between a part at HAZARDOUS VOLTAGE and an accessible conductive part of the external ENCLOSURE of PLUGGABLE EQUIPMENT TYPE A.

Table G.2 – Minimum clearances up to 2 000 m above sea level

CLEARANCES in millimetres

REQUIRED WITHSTAND VOLTAGE	Minimum CLEARANCES in air		
	FUNCTIONAL INSULATION	BASIC INSULATION and SUPPLEMENTARY INSULATION	REINFORCED INSULATION
V peak or d.c.			
Up to 400	0,1	0,2 (0,1)	0,4 (0,2)
800	0,1	0,2	0,4
1 000	0,2	0,3	0,6
1 200	0,3	0,4	0,8
1 500	0,5	0,8 (0,5)	1,6 (1)
2 000	1	1,3 (1)	2,6 (2)
2 500	1,5	2 (1,5)	4 (3)
3 000	2	2,6 (2)	5,2 (4)
4 000	3	4 (3)	6
6 000	5,5	7,5	11
8 000	8	11	16
10 000	11	15	22
12 000	14	19	28
15 000	18	24	36
25 000	33	44	66
40 000	60	80	120
50 000	75	100	150
60 000	90	120	180
80 000	130	173	260
100 000	170	227	340

1) Except in PRIMARY CIRCUITS in item a) of clause G.4, linear interpolation is permitted between the nearest two points, the calculated minimum CLEARANCES being rounded up to the next higher 0,1 mm increment.

2) The values in parentheses are applicable only if manufacturing is subjected to a quality control programme, that provides at least the same level of assurance as the example given in clause R.2. In particular, DOUBLE INSULATION and REINFORCED INSULATION shall be subjected to ROUTINE TESTS for electric strength.

3) Compliance with a minimum CLEARANCE value of 5,0 mm or greater for SECONDARY CIRCUITS is not required if a minimum CLEARANCE of 5,0 mm is maintained and the CLEARANCE path is:

- entirely through air; or
- wholly or partly along the surface of an insulation of Material Group I;

and the insulation involved passes an electric strength test according to 5.2.2, using:

- an a.c. test voltage whose r.m.s. value is equal to 1,06 times the PEAK WORKING VOLTAGE; or
- a d.c. test voltage equal to the peak value of the a.c. test voltage prescribed above.

If the CLEARANCE path is partly along the surface of a material that is not of Material Group I, the electric strength test is conducted in the air gap only.

Compliance is checked by measurement, taking into account annex F. There is no electric strength test to verify CLEARANCES. The following conditions are applicable:

- movable parts shall be placed in the most unfavourable position;*
- the force tests of 4.2.2, 4.2.3 and 4.2.4 apply;*
- when measuring CLEARANCES from an ENCLOSURE of insulating material through a slot or opening in the ENCLOSURE, the accessible surface shall be considered to be conductive as if it were covered by metal foil wherever it can be touched by the test finger, figure 2A (see 2.1.1.1), applied without appreciable force (see figure F.12, point B).*

Annex H (normative)

Ionizing radiation (see 4.3.13)

Equipment which might produce ionizing radiation is checked by measuring the amount of radiation.

The amount of radiation is determined by means of a radiation monitor of the ionizing chamber type with an effective area of 10 cm² or by measuring equipment of other types giving equivalent results.

Measurements are made with the equipment on test operating at the most unfavourable supply voltage (see 1.4.5) and with OPERATOR controls and service controls adjusted so as to give maximum radiation whilst maintaining the equipment operative for normal use.

Internal preset controls not intended to be adjusted during the lifetime of the equipment are not considered to be service controls.

At any point 5 cm from the surface of the OPERATOR ACCESS AREA, the dose-rate shall not exceed 36 pA/kg (5 μSv/h) (0,5 mR/h) (see note 1). Account is taken of the background level.

NOTE 1 This value appears in ICRP 15.

NOTE 2 In the member countries of CENELEC, the amount of ionizing radiation is regulated by European Council Directive 96/29/Euratom of 13 May 1996. This Directive requires that at any point 10 cm from the surface of the equipment, the dose-rate shall not exceed 1 μSv/h (0,1 mR/h) taking account of the background level.

Annex J (normative)

Table of electrochemical potentials (see 2.6.5.6)

Table J.1 – Electrochemical potentials (V)

Magnesium, magnesium alloys	Zinc, zinc alloys	80 tin/20 Zn on steel, Zn on iron or steel	Aluminium	Cd on steel	Al/Mg alloy	Mild steel	Duralumin	Lead	Cr on steel, soft solder	Cr on Ni on steel, tin on steel	12 % Cr stainless steel	High Cr stainless steel	Copper, copper alloys	Silver solder, Austenitic stainless steel	Ni on steel	Silver	Rh on Ag on Cu, silver/gold alloy	Carbon	Gold, platinum
0	0,5	0,55	0,7	0,8	0,85	0,9	1,0	1,05	1,1	1,15	1,25	1,25	1,35	1,4	1,45	1,6	1,65	1,7	1,75
0	0,05	0,2	0,35	0,4	0,5	0,55	0,6	0,65	0,7	0,85	0,9	0,95	1,05	1,1	1,15	1,2	1,25	1,25	1,25
0	0	0,15	0,25	0,3	0,35	0,4	0,5	0,6	0,7	0,8	0,85	0,9	1,05	1,1	1,15	1,2	1,25	1,25	1,25
0	0	0	0,1	0,15	0,2	0,3	0,35	0,4	0,45	0,55	0,7	0,75	0,9	0,95	1,0	1,05	1,1	1,15	1,2
0	0	0	0,05	0,1	0,2	0,25	0,3	0,35	0,45	0,55	0,6	0,65	0,8	0,85	0,9	0,95	1,0	1,05	1,05
Ag	Silver	Aluminium	0	0,05	0,15	0,2	0,2	0,3	0,4	0,5	0,55	0,6	0,75	0,8	0,85	0,9	0,95	1,0	0,95
Al	Aluminium	0	0,15	0,2	0,2	0,2	0,3	0,4	0,5	0,55	0,6	0,65	0,75	0,8	0,85	0,9	0,95	1,0	0,95
Cd	Cadmium	0	0,1	0,15	0,2	0,25	0,35	0,45	0,5	0,55	0,7	0,75	0,8	0,85	0,9	0,95	1,0	1,05	1,05
Cr	Chromium	0	0	0,05	0,1	0,15	0,25	0,35	0,4	0,45	0,6	0,65	0,7	0,75	0,8	0,85	0,9	1,0	1,05
Cu	Copper	0	0,05	0,1	0,15	0,2	0,25	0,3	0,35	0,4	0,45	0,6	0,65	0,7	0,75	0,8	0,9	1,0	1,05
Mg	Magnesium	0	0,05	0,1	0,15	0,2	0,25	0,3	0,35	0,4	0,45	0,6	0,65	0,7	0,75	0,8	0,9	1,0	1,05
Ni	Nickel	0	0	0,5	0,1	0,2	0,3	0,35	0,4	0,45	0,6	0,65	0,7	0,75	0,8	0,9	1,0	1,05	1,05
Rh	Rhodium	0	0,05	0,15	0,25	0,3	0,35	0,4	0,45	0,6	0,65	0,7	0,75	0,8	0,9	0,95	1,0	1,05	1,05
Zn	Zinc	0	0,05	0,15	0,25	0,3	0,35	0,4	0,45	0,6	0,65	0,7	0,75	0,8	0,9	0,95	1,0	1,05	1,05
		0	0	0,1	0,2	0,25	0,3	0,35	0,4	0,45	0,6	0,65	0,7	0,75	0,8	0,9	0,95	1,0	1,05
		0	0	0,1	0,2	0,25	0,3	0,35	0,4	0,45	0,6	0,65	0,7	0,75	0,8	0,9	0,95	1,0	1,05
		0	0	0,1	0,2	0,25	0,3	0,35	0,4	0,45	0,6	0,65	0,7	0,75	0,8	0,9	0,95	1,0	1,05
		0	0	0,1	0,2	0,25	0,3	0,35	0,4	0,45	0,6	0,65	0,7	0,75	0,8	0,9	0,95	1,0	1,05
		0	0	0,1	0,2	0,25	0,3	0,35	0,4	0,45	0,6	0,65	0,7	0,75	0,8	0,9	0,95	1,0	1,05
		0	0	0,1	0,2	0,25	0,3	0,35	0,4	0,45	0,6	0,65	0,7	0,75	0,8	0,9	0,95	1,0	1,05
		0	0	0,1	0,2	0,25	0,3	0,35	0,4	0,45	0,6	0,65	0,7	0,75	0,8	0,9	0,95	1,0	1,05
		0	0	0,1	0,2	0,25	0,3	0,35	0,4	0,45	0,6	0,65	0,7	0,75	0,8	0,9	0,95	1,0	1,05
		0	0	0,1	0,2	0,25	0,3	0,35	0,4	0,45	0,6	0,65	0,7	0,75	0,8	0,9	0,95	1,0	1,05
		0	0	0,1	0,2	0,25	0,3	0,35	0,4	0,45	0,6	0,65	0,7	0,75	0,8	0,9	0,95	1,0	1,05
		0	0	0,1	0,2	0,25	0,3	0,35	0,4	0,45	0,6	0,65	0,7	0,75	0,8	0,9	0,95	1,0	1,05
		0	0	0,1	0,2	0,25	0,3	0,35	0,4	0,45	0,6	0,65	0,7	0,75	0,8	0,9	0,95	1,0	1,05
		0	0	0,1	0,2	0,25	0,3	0,35	0,4	0,45	0,6	0,65	0,7	0,75	0,8	0,9	0,95	1,0	1,05
		0	0	0,1	0,2	0,25	0,3	0,35	0,4	0,45	0,6	0,65	0,7	0,75	0,8	0,9	0,95	1,0	1,05
		0	0	0,1	0,2	0,25	0,3	0,35	0,4	0,45	0,6	0,65	0,7	0,75	0,8	0,9	0,95	1,0	1,05
		0	0	0,1	0,2	0,25	0,3	0,35	0,4	0,45	0,6	0,65	0,7	0,75	0,8	0,9	0,95	1,0	1,05
		0	0	0,1	0,2	0,25	0,3	0,35	0,4	0,45	0,6	0,65	0,7	0,75	0,8	0,9	0,95	1,0	1,05
		0	0	0,1	0,2	0,25	0,3	0,35	0,4	0,45	0,6	0,65	0,7	0,75	0,8	0,9	0,95	1,0	1,05
		0	0	0,1	0,2	0,25	0,3	0,35	0,4	0,45	0,6	0,65	0,7	0,75	0,8	0,9	0,95	1,0	1,05
		0	0	0,1	0,2	0,25	0,3	0,35	0,4	0,45	0,6	0,65	0,7	0,75	0,8	0,9	0,95	1,0	1,05
		0	0	0,1	0,2	0,25	0,3	0,35	0,4	0,45	0,6	0,65	0,7	0,75	0,8	0,9	0,95	1,0	1,05
		0	0	0,1	0,2	0,25	0,3	0,35	0,4	0,45	0,6	0,65	0,7	0,75	0,8	0,9	0,95	1,0	1,05
		0	0	0,1	0,2	0,25	0,3	0,35	0,4	0,45	0,6	0,65	0,7	0,75	0,8	0,9	0,95	1,0	1,05
		0	0	0,1	0,2	0,25	0,3	0,35	0,4	0,45	0,6	0,65	0,7	0,75	0,8	0,9	0,95	1,0	1,05
		0	0	0,1	0,2	0,25	0,3	0,35	0,4	0,45	0,6	0,65	0,7	0,75	0,8	0,9	0,95	1,0	1,05
		0	0	0,1	0,2	0,25	0,3	0,35	0,4	0,45	0,6	0,65	0,7	0,75	0,8	0,9	0,95	1,0	1,05
		0	0	0,1	0,2	0,25	0,3	0,35	0,4	0,45	0,6	0,65	0,7	0,75	0,8	0,9	0,95	1,0	1,05
		0	0	0,1	0,2	0,25	0,3	0,35	0,4	0,45	0,6	0,65	0,7	0,75	0,8	0,9	0,95	1,0	1,05
		0	0	0,1	0,2	0,25	0,3	0,35	0,4	0,45	0,6	0,65	0,7	0,75	0,8	0,9	0,95	1,0	1,05
		0	0	0,1	0,2	0,25	0,3	0,35	0,4	0,45	0,6	0,65	0,7	0,75	0,8	0,9	0,95	1,0	1,05
		0	0	0,1	0,2	0,25	0,3	0,35	0,4	0,45	0,6	0,65	0,7	0,75	0,8	0,9	0,95	1,0	1,05
		0	0	0,1	0,2	0,25	0,3	0,35	0,4	0,45	0,6	0,65	0,7	0,75	0,8	0,9	0,95	1,0	1,05
		0	0	0,1	0,2	0,25	0,3	0,35	0,4	0,45	0,6	0,65	0,7	0,75	0,8	0,9	0,95	1,0	1,05
		0	0	0,1	0,2	0,25	0,3	0,35	0,4	0,45	0,6	0,65	0,7	0,75	0,8	0,9	0,95	1,0	1,05
		0	0	0,1	0,2	0,25	0,3	0,35	0,4	0,45	0,6	0,65	0,7	0,75	0,8	0,9	0,95	1,0	1,05
		0	0	0,1	0,2	0,25	0,3	0,35	0,4	0,45	0,6	0,65	0,7	0,75	0,8	0,9	0,95	1,0	1,05
		0	0	0,1	0,2	0,25	0,3	0,35	0,4	0,45	0,6	0,65	0,7	0,75	0,8	0,9	0,95	1,0	1,05
		0	0	0,1	0,2	0,25	0,3	0,35	0,4	0,45	0,6	0,65	0,7	0,75	0,8	0,9	0,95	1,0	1,05
		0	0	0,1	0,2	0,25	0,3	0,35	0,4	0,45	0,6	0,65	0,7	0,75	0,8	0,9	0,95	1,0	1,05
		0	0	0,1	0,2	0,25	0,3	0,35	0,4	0,45	0,6	0,65	0,7	0,75	0,8	0,9	0,95	1,0	1,05
		0	0	0,1	0,2	0,25	0,3	0,35	0,4	0,45	0,6	0,65	0,7	0,75	0,8	0,9	0,95	1,0	1,05
		0	0	0,1	0,2	0,25	0,3	0,35	0,4	0,45	0,6	0,65	0,7	0,75	0,8	0,9	0,95	1,0	1,05
		0	0	0,1	0,2	0,25	0,3	0,35	0,4	0,45	0,6	0,65	0,7	0,75	0,8	0,9	0,95	1,0	1,05
		0	0	0,1	0,2	0,25	0,3	0,35	0,4	0,45	0,6	0,65	0,7	0,75	0,8	0,9	0,95	1,0	1,05
		0	0	0,1	0,2	0,25	0,3	0,35	0,4	0,45	0,6	0,65	0,7	0,75	0,8	0,9	0,95	1,0	1,05
		0	0	0,1	0,2	0,25	0,3	0,35	0,4	0,45	0,6	0,65	0,7	0,75	0,8	0,9	0,95	1,0	1,05
		0	0	0,1	0,2	0,25	0,3	0,35	0,4	0,45	0,6	0,65	0,7	0,75	0,8	0,9	0,95	1,0	1,05
		0	0	0,1	0,2	0,25	0,3	0,35	0,4	0,45	0,6	0,65	0,7	0,75	0,8	0,9	0,95	1,0	1,05
		0	0	0,1	0,2	0,25	0,3	0,35	0,4	0,45	0,6	0,65	0,7	0,75	0,8	0,9	0,95	1,0	1,05
		0	0	0,1	0,2	0,25	0,3	0,35	0,4	0,45	0,6	0,65	0,7	0,75	0,8				

Annex K (normative)

Thermal controls (see 1.5.3 and 5.3.7)

K.1 Making and breaking capacity

THERMOSTATS and TEMPERATURE LIMITERS shall have adequate making and breaking capacity.

Compliance is checked by subjecting three samples either to the tests of clauses K.2 and K.3, or to the tests of clause K.4, as appropriate. If the component is T-marked, one sample is tested with the switch part at room temperature, and two samples with the switch part at a temperature in accordance with the marking.

Components not marked with individual ratings are tested either in the equipment or separately, whichever is more convenient, but, if tested separately, the test conditions are to be similar to those occurring in the equipment.

During the tests, no sustained arcing shall occur.

After the tests, the samples shall show no damage impairing their further use. Electrical connections shall not have worked loose. The component shall withstand an electric strength test as specified in 5.2.2, except that the test voltage for the insulation between the contacts is twice the voltage applied when the equipment is operated at RATED VOLTAGE or at the upper voltage of the RATED VOLTAGE RANGE.

For test purposes the switching frequency can be increased above the normal switching frequency inherent to the equipment, provided that no greater risk of failure is induced.

If it is not possible to test the component separately, three samples of the equipment in which it is used are tested.

K.2 Thermostat reliability

THERMOSTATS are caused, thermally, to perform 200 cycles of operation (200 makes and 200 breaks) when the equipment is operated at a voltage equal to 1,1 times RATED VOLTAGE or to 1,1 times the upper voltage of the RATED VOLTAGE RANGE, and under NORMAL LOAD.

K.3 Thermostat endurance test

THERMOSTATS are caused, thermally, to perform 10 000 cycles of operation (10 000 makes and 10 000 breaks) when the equipment is operated at RATED VOLTAGE or at the upper voltage of the RATED VOLTAGE RANGE, and under NORMAL LOAD.

K.4 Temperature limiter endurance

TEMPERATURE LIMITERS are caused, thermally, to perform 1 000 cycles of operation (1 000 makes and 1 000 breaks) when the equipment is operated at RATED VOLTAGE, or at the upper voltage of the RATED VOLTAGE RANGE, and under NORMAL LOAD.

K.5 Thermal cut-out reliability

THERMAL CUT-OUTS shall operate reliably.

Compliance is checked while the equipment is operating under the conditions specified in 4.5.1.

AUTOMATIC RESET THERMAL CUT-OUTS are caused to operate 200 times; MANUAL RESET THERMAL CUT-OUTS are reset after each operation and thus caused to operate 10 times.

After the tests, the samples shall show no damage impairing their further use.

Forced cooling and resting periods are permitted to prevent damage to the equipment.

K.6 Stability of operation

THERMOSTATS, TEMPERATURE LIMITERS and THERMAL CUT-OUTS shall be so constructed that their setting is not changed appreciably by heating, vibration, etc., occurring in normal use.

Compliance is checked by inspection during the abnormal operation tests of 5.3.

Annex L (normative)

Normal load conditions for some types of electrical business equipment (see 1.2.2.1 and 4.5.1)

L.1 Typewriters

Typewriters are energized with no load applied until steady conditions are established. Manually keyed machines are then operated at a rate of 200 characters per minute, with a line transport operation after each 60 characters including spaces, until steady conditions are established. Automatically operated machines are operated at the maximum typing speed recommended in the manufacturer's instruction sheet.

L.2 Adding machines and cash registers

For adding machines and cash registers, four digit numbers are entered or set and the repeat key or operating bar activated 24 times per minute, until steady conditions are established, the four digit number to be used being that which loads the machine most heavily. If the cash register has a drawer which opens every time an item is rung up, the cash register is operated at a rate of 15 operation cycles per minute, the drawer being shut after each operation, until steady conditions are established. For an adding machine or cash register, an operation consists of the OPERATOR setting or inserting the figures with which the machine is to operate and then pressing the operating bar, repeating key or the like for each operation.

L.3 Erasers

Erasers are operated continuously at no load for 1 h.

L.4 Pencil sharpeners

For a pencil sharpener, five new pencils are each sharpened eight times according to the following timetable. Except for new pencils, the point is broken off before each sharpening.

<i>Sharpening period</i>	<i>4 s for a new pencil</i>
	<i>2 s for subsequent sharpenings</i>
<i>Interval between sharpenings</i>	<i>6 s</i>
<i>Interval between pencils</i>	<i>60 s</i>

All times are approximate.

L.5 Duplicators and copy machines

Duplicators and copy machines are operated continuously at maximum speed until steady conditions are established. It is permitted to introduce a rest period of 3 min after each 500 copies if this is compatible with the design of the machine.

L.6 Motor-operated files

Motor-operated files are loaded to simulate a condition of unbalance caused by uneven distribution of the contents. During operation, the unbalanced load is moved approximately one-third of the total carrier travel of the path that will impose maximum loading during each operation. The operation is repeated each 15 s until steady conditions are established.

A load caused by the non-uniform distribution of the contents is permitted to be simulated as follows.

In the case of vertical transport, three-eighths of the filing area are to be loaded, without leaving clearances, with three-eighths of the admissible load. The entire transport way is to be travelled with this load. The transport cycle is to be repeated, at intervals of 10 s, until the temperature has stabilized.

In the case of a different transport, for example, horizontal or circular mode of transport, the total load is moved over the whole transport way. The transport cycle is to be repeated, at intervals of 15 s, until the temperature has stabilized.

L.7 Other business equipment

Other business equipment is operated according to the most unfavourable way of operation given in the operating instructions.

Annex M (normative)

Criteria for telephone ringing signals (see 2.3.1)

M.1 Introduction

The two alternative methods described in this annex reflect satisfactory experience in different parts of the world. Method A is typical of analogue telephone networks in Europe, and Method B of those in North America. The two methods result in standards of electrical safety which are broadly equivalent.

M.2 Method A

This method requires that the currents I_{TS1} and I_{TS2} flowing through a 5 000 Ω resistor, between any two conductors or between one conductor and earth do not exceed the limits specified, as follows.

a) *For normal operation, I_{TS1} , the current determined from the calculated or measured current for any single active ringing period t_1 (as defined in figure M.1), does not exceed:*

- 1) *for cadenced ringing ($t_1 < \infty$), the current given by the curve of figure M.2 at t_1 ;*
- 2) *for continuous ringing ($t_1 = \infty$), 16 mA.*

I_{TS1} , in mA, is as given by

$$I_{TS1} = \frac{I_p}{\sqrt{2}} \quad \text{for } (t_1 \leq 600 \text{ ms})$$

$$I_{TS1} = \frac{t_1 - 600}{600} \times \frac{I_{pp}}{2\sqrt{2}} + \frac{1\,200 - t_1}{600} \times \frac{I_p}{\sqrt{2}} \quad \text{for } (600 \text{ ms} < t_1 < 1\,200 \text{ ms})$$

$$I_{TS1} = \frac{I_{pp}}{2\sqrt{2}} \quad \text{for } (t_1 \geq 1\,200 \text{ ms})$$

where

I_p is the peak current, in mA, of the relevant waveform given in figure M.3;

I_{pp} is the peak-to-peak current, in mA, of the relevant waveform given in figure M.3;

t_1 is expressed in ms.

- b) For normal operation, I_{TS2} , the average current for repeated bursts of a cadenced ringing signal calculated for one ringing cadence cycle t_2 (as defined in figure M.1), does not exceed 16 mA r.m.s.

I_{TS2} in mA is as given by

$$I_{TS2} = \left[\frac{t_1}{t_2} \times I_{TS1}^2 + \frac{t_2 - t_1}{t_2} \times \frac{I_{dc}^2}{3,75^2} \right]^{1/2}$$

where

I_{TS1} in mA, is as given by item a) of M.2);

I_{dc} is the d.c. current in mA flowing through the 5 000 Ω resistor during the non-active period of the cadence cycle;

t_1 and t_2 are expressed in milliseconds.

NOTE The frequencies of telephone ringing voltages are normally within the range of 14 Hz to 50 Hz.

- c) Under single fault conditions, including where cadenced ringing becomes continuous:

- I_{TS1} shall not exceed the current given by the curve of figure M.2, or 20 mA, whichever is greater;
- I_{TS2} shall not exceed a limit of 20 mA.

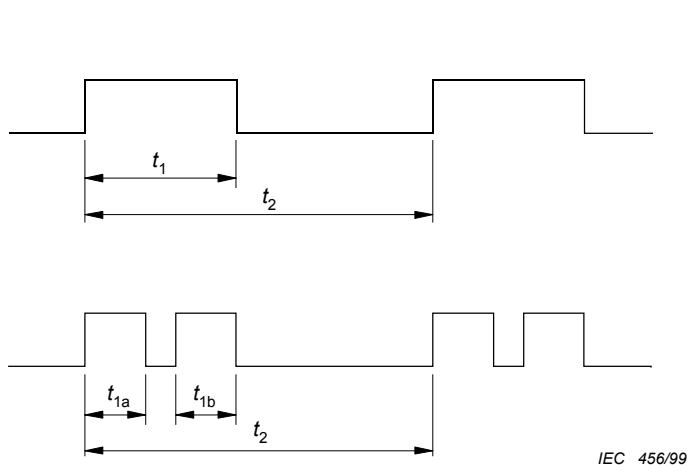

t_1 is:

- the duration of a single ringing period, where the ringing is active for the whole of the single ringing period;
- the sum of the active periods of ringing within the single ringing period, where the single ringing period contains two or more discrete active periods of ringing, as in the example shown, for which $t_1 = t_{1a} + t_{1b}$.

t_2 is the duration of one complete cadence cycle.

Figure M.1 – Definition of ringing period and cadence cycle

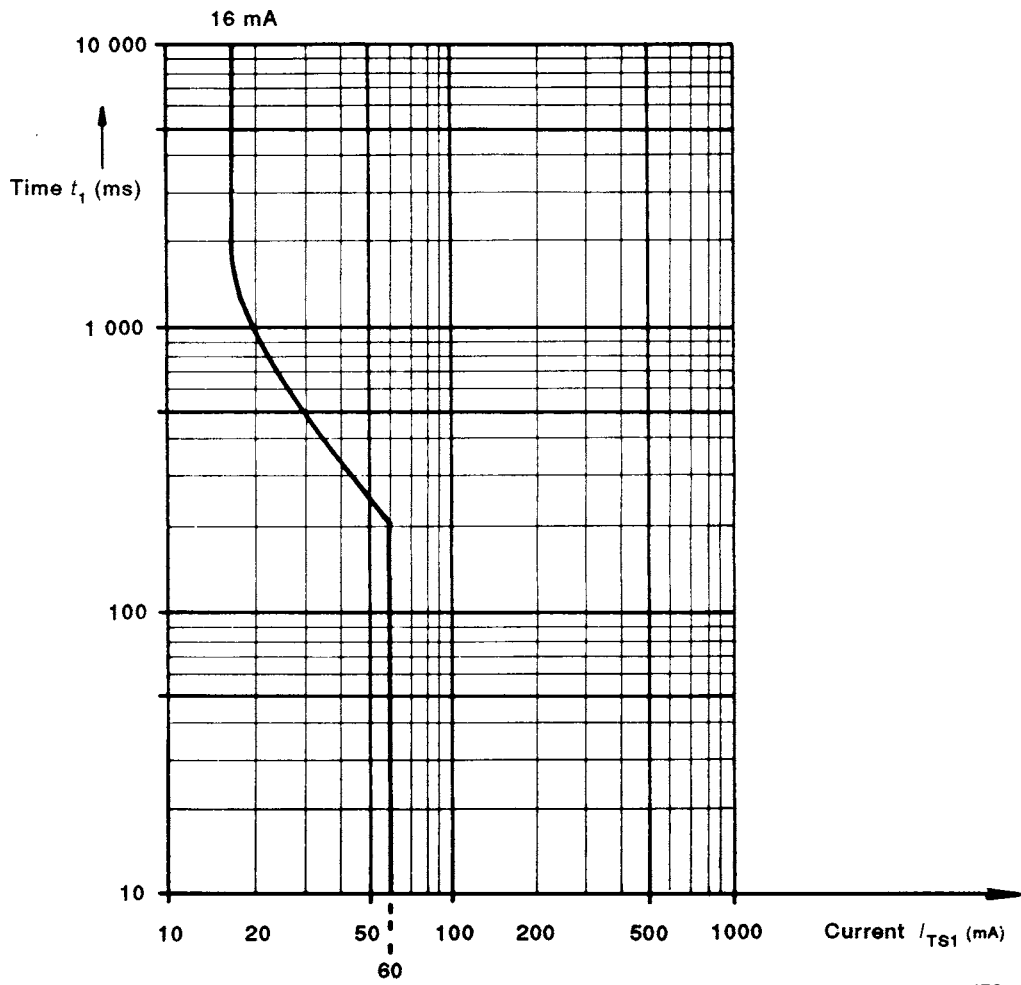

IEC 457/99

Figure M.2 - I_{TS1} limit curve for cadenced ringing signal

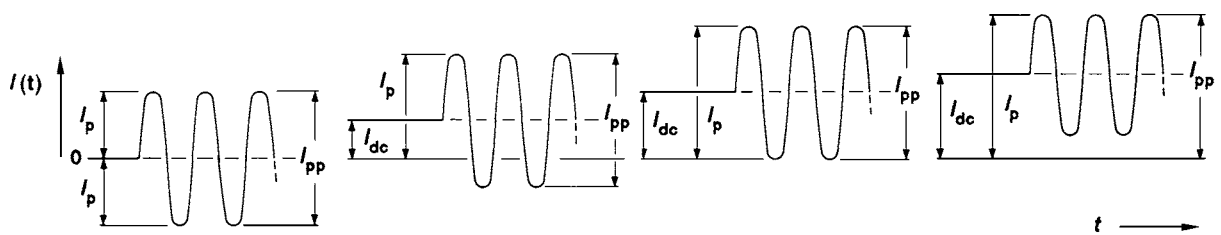

IEC 607/91

Figure M.3 - Peak and peak-to-peak currents

M.3 Method B

NOTE This method is based on USA CFR 47 ("FCC Rules") Part 68, Sub-part D, with additional requirements that apply under fault conditions.

M.3.1 Ringing signal

M.3.1.1 Frequency

The ringing signal shall use only frequencies whose fundamental component is equal to or less than 70 Hz.

M.3.1.2 Voltage

The ringing voltage shall be less than 300 V peak-to-peak and less than 200 V peak with respect to earth, measured across a resistance of at least 1 M Ω .

M.3.1.3 Cadence

The ringing voltage shall be interrupted to create quiet intervals of at least 1 s duration separated by no more than 5 s. During the quiet intervals, the voltage to earth shall not exceed 56,5 V d.c.

M.3.1.4 Single fault current

Where cadenced ringing becomes continuous as a consequence of a single fault, the current through a 5 000 Ω resistor connected between any two output conductors or between one output conductor and earth shall not exceed 56,5 mA peak-to-peak, as shown in figure M.3.

M.3.2 Tripping device and monitoring voltage

M.3.2.1 Conditions for use of a tripping device or a monitoring voltage

A ringing signal circuit shall include a tripping device as specified in M.3.2.2, or provide a monitoring voltage as specified in M.3.2.3, or both, depending on the current through a specified resistance connected between the ringing signal generator and earth, as follows:

- if the current through a 500 Ω resistor does not exceed 100 mA peak-to-peak, neither a tripping device nor a monitoring voltage is required;
- if the current through a 1 500 Ω resistor exceeds 100 mA peak-to-peak, a tripping device shall be included. If the tripping device meets the trip criteria specified in figure M.4 with $R = 500 \Omega$ no monitoring voltage is required. If, however, the tripping device only meets the trip criteria with $R = 1 500 \Omega$, a monitoring voltage shall also be provided;
- if the current through a 500 Ω resistor exceeds 100 mA peak-to-peak, but the current through a 1 500 Ω resistor does not exceed this value, either:
 - a tripping device shall be provided, meeting the trip criteria specified in figure M.4 with $R = 500 \Omega$ or
 - a monitoring voltage shall be provided.

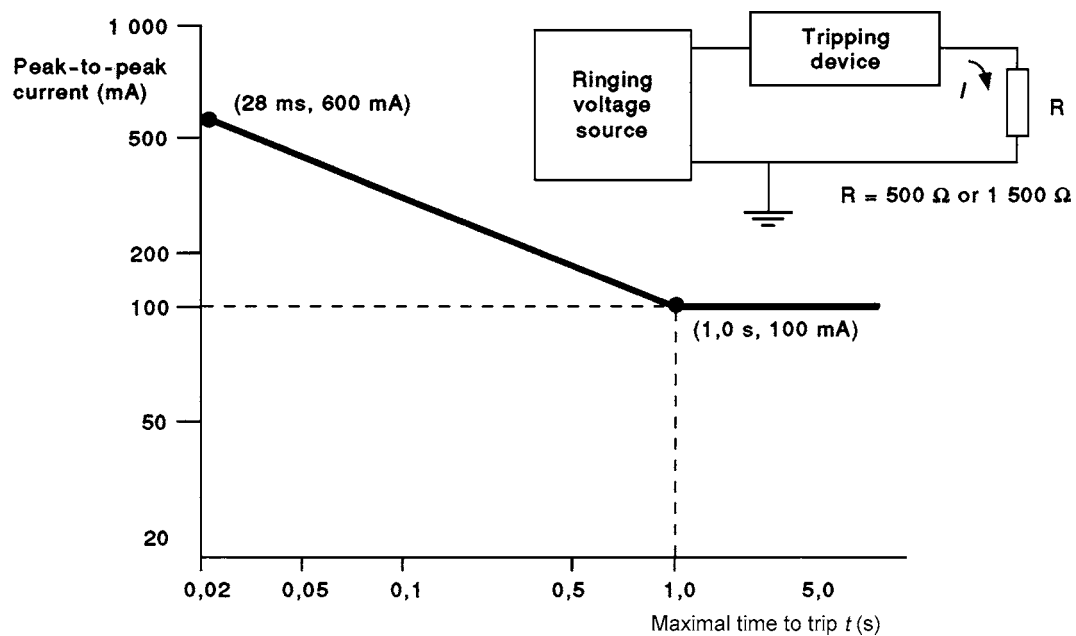

NOTE 1 t is measured from the time of connection of the resistor R to the circuit.

IEC 458/99

NOTE 2 The sloping part of the curve is defined as $I = 100/\sqrt{t}$.

Figure M.4 – Ringing voltage trip criteria

M.3.2.2 Tripping device

A series current-sensitive tripping device in the ringlead which will trip ringing as specified in figure M.4.

M.3.2.3 Monitoring voltage

A voltage to earth on the tip or ring conductor with a magnitude of at least 19 V peak, but not exceeding 56,5 V d.c., whenever the ringing voltage is not present (idle state).

Annex N (normative)

Impulse test generators

(see 2.10.3.4, 6.2.2.1, 7.3.2 and clause G.5)

NOTE Extreme care is necessary when using these test generators due to the high electric charge stored in the capacitor C_1 .

N.1 ITU-T impulse test generators

The circuit in figure N.1, using the component values in references 1 and 2 of table N.1, is used to generate impulses, the C_1 capacitor being charged initially to a voltage U_c .

Circuit reference 1 of table N.1 generates 10/700 μs impulses (10 μs virtual front time, 700 μs virtual time to half value) as specified in ITU-T Recommendation K.17 to simulate lightning interference in the TELECOMMUNICATION NETWORK.

Circuit reference 2 of table N.1 generates 1,2/50 μs impulses (1,2 μs virtual front time, 50 μs virtual time to half value) as specified in ITU-T Recommendation K.21 to simulate transients in power distribution systems.

The impulse wave shapes are under open-circuit conditions and can be different under load conditions.

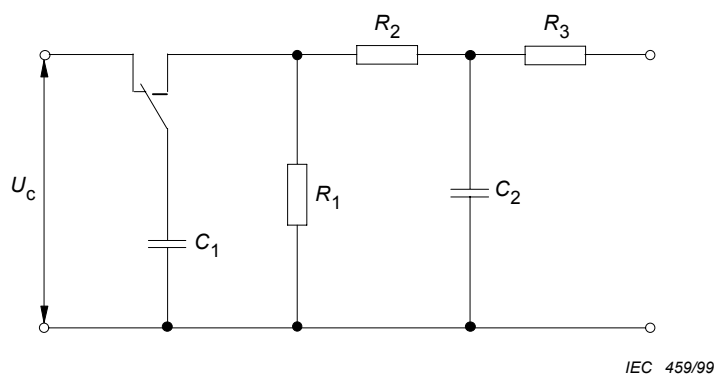

Figure N.1 – ITU-T impulse test generator circuit

N.2 IEC 60065 impulse test generator

The circuit in figure N.2, using the component values reference 3 in table N.1, is used to generate impulses, the C_1 capacitor being charged initially to a voltage U_c . The switch used in figure N.2 is a critical part of the circuit. See IEC 60065:1998, 10.1, for further information.

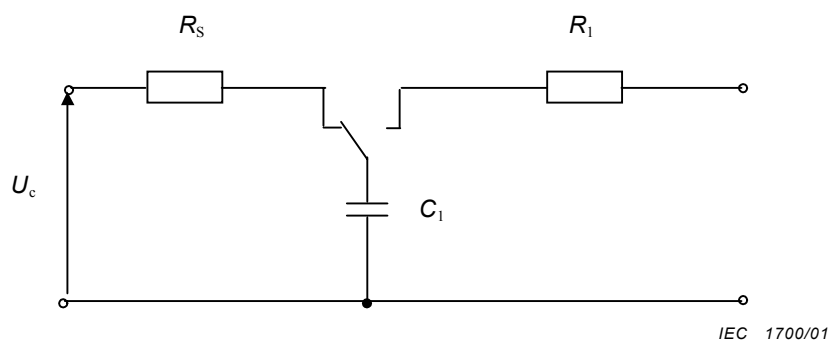

Figure N.2 – IEC 60065 impulse test generator circuit

Table N.1 – Component values for figures N.1 and N.2

Reference	Test impulse	Figure	C_1	C_2	R_1	R_2	R_3	R_s	See
1	10/700 μ s	N.1	20 μ F	0,2 μ F	50 Ω	15 Ω	25 Ω	–	2.10.3.4, 6.2.2.1 and item b) of clause G.5
2	1,2/50 μ s	N.1	1 μ F	33 nF	76 Ω	13 Ω	25 Ω	–	2.10.3.4 and clause G.5
3	–	N.2	1 nF	–	1 k Ω	–	–	15 M Ω	7.3.2

Reference 1 impulse is typical of voltages induced into telephone wires and coaxial cables in long outdoor cable runs due to nearby lightning strikes to earth.

Reference 2 impulse is typical of earth potential rises due to either lightning strikes to power lines or power line faults.

Reference 3 impulse is typical of voltages induced into antenna system wiring due to nearby lightning strikes to earth.

Annex P (normative)

Normative references

The following normative documents contain provisions which, through reference in this text, constitute provisions of this part of IEC 60950. For dated references, subsequent amendments to, or revisions of, any of these publications do not apply. However, parties to agreements based on this part of IEC 60950 are encouraged to investigate the possibility of applying the most recent editions of the normative documents indicated below. For undated references, the latest edition of the normative document referred to applies. Members of IEC and ISO maintain registers of currently valid International Standards.

IEC 60050-151, *International Electrotechnical Vocabulary – Chapter 151: Electrical and magnetic devices*

IEC 60050-195, *International Electrotechnical Vocabulary – Chapter 195: Earthing and protection against electric shock*

IEC 60065:1998, *Audio, video and similar electronic apparatus – Safety requirements*

IEC 60073:1996, *Basic and safety principles for man-machine interface, marking and identification – Coding principles for indication devices and actuators*

IEC/TR 60083:1997, *Plugs and socket-outlets for domestic and similar general use standardized in member countries of IEC*

IEC 60085:1984, *Thermal evaluation and classification of electrical insulation*

IEC 60112:1979, *Method for determining the comparative and the proof tracking indices of solid insulating materials under moist conditions*

IEC 60216-4-1:1990, *Guide for the determination of thermal endurance properties of electrical insulating materials – Part 4: Ageing ovens – Section 1: Single-chamber ovens*

IEC 60227 (all parts), *Polyvinyl chloride insulated cables of rated voltages up to and including 450/750 V*

IEC 60245 (all parts), *Rubber insulated cables – Rated voltages up to and including 450/750 V*

IEC 60309 (all parts), *Plugs, socket-outlets and couplers for industrial purposes*

IEC 60317-43:1997, *Specifications for particular types of winding wires – Part 43: Aromatic polyimide tape wrapped round copper wire, class 240*

IEC 60320 (all parts), *Appliance couplers for household and similar general purposes*

IEC 60364-3:1993, *Electrical installations of buildings – Part 3: Assessment of general characteristics*

IEC 60364-4-41:1992, *Electrical installations of buildings – Part 4: Protection for safety – Chapter 41: Protection against electric shock*

IEC 60384-14:1993, *Fixed capacitors for use in electronic equipment – Part 14: Sectional specification: Fixed capacitors for electromagnetic interference suppression and connection to the supply mains*

IEC 60417-1, *Graphical symbols for use on equipment – Part 1: Overview and application*

IEC 60664-1:1992, *Insulation coordination for equipment within low-voltage systems – Part 1: Principles, requirements and tests*

IEC 60695-2-2:1991, *Fire hazard testing – Part 2: Test methods – Section 2: Needle-flame test*

IEC 60695-2-11:2000, *Fire hazard testing – Part 2-11: Glowing /hot-wire based test methods – Glow-wire flammability test method for end-products*

IEC 60695-2-20:1995, *Fire hazard testing – Part 2: Glowing/Hot wire based test methods – Section 20: Hot-wire coil ignitability test on materials*

IEC 60695-10-2:1995, *Fire hazard testing – Part 10: Guidance and test methods for the minimization of the effects of abnormal heat on electrotechnical products involved in fires – Section 2: Method for testing products made from non-metallic materials for resistance to heat using the ball pressure test*

IEC/TS 60695-11-3:2000, *Fire hazard testing – Part 11-3: Test flames – 500 W flames – Apparatus and confirmational test methods*

IEC/TS 60695-11-4:2000, *Fire hazard testing – Part 11-4: Test flames – 50 W flames – Apparatus and confirmational test methods*

IEC 60695-11-10:1999, *Fire hazard testing – Part 11-10: Test flames – 50 W horizontal and vertical flame test methods*

IEC 60695-11-20:1999, *Fire hazard testing – Part 11-20: Test flames – 500 W flame test methods*

IEC 60730-1:1999, *Automatic electrical controls for household and similar use – Part 1: General requirements*

IEC 60825-1:1993, *Safety of laser products – Part 1: Equipment classification, requirements and user's guide*

IEC 60825-2:2000, *Safety of laser products – Part 2: Safety of optical fibre communication systems*

IEC/TR 60825-9:1999, *Safety of laser products – Part 9: Compilation of maximum permissible exposure to incoherent optical radiation*

IEC 60851-3:1996, *Winding wires – Test methods – Part 3: Mechanical properties*

IEC 60851-5:1996, *Winding wires – Test methods – Part 5: Electrical properties*

IEC 60851-6:1996, *Methods of test for winding wires – Part 6: Thermal properties*

IEC 60885-1:1987, *Electrical test methods for electric cables – Part 1: Electrical tests for cables, cords and wires for voltages up to and including 450/750 V*

IEC 60990:1999, *Methods of measurement of touch current and protective conductor current*

IEC 61058-1:2000, *Switches for appliances – Part 1: General requirements*

IEC 61965:2000, *Mechanical safety of cathode ray tubes*

ISO 178:1993, *Plastics – Determination of flexural properties*

ISO 179 (all parts), *Plastics – Determination of Charpy impact properties*

ISO 180:2000, *Plastics – Determination of Izod impact strength*

ISO 261:1998, *ISO General-purpose metric screw threads – General plan*

ISO 262:1998, *ISO General-purpose metric screw threads – Selected sizes for screws, bolts and nuts*

ISO 527 (all parts), *Plastics – Determination of tensile properties*

ISO 3864:1984, *Safety colours and safety signs*

ISO 4892 (all parts), *Plastics, Methods of exposure to laboratory light sources*

ISO 7000:1989, *Graphical symbols for use on equipment – Index and synopsis*

ISO 8256:1990, *Plastics – Determination of tensile-impact strength*

ISO 9772:1994, *Cellular plastics – Determination of horizontal burning characteristics of small specimens subjected to a small flame*

ISO 9773:1998, *Plastics – Determination of burning behaviour of thin flexible vertical specimens in contact with a small-flame ignition source*

ITU-T Recommendation K.17: 1988, *Tests on power-fed repeaters using solid-state devices in order to check the arrangements for protection from external interference*

ITU-T Recommendation K.21: 2000, *Resistibility of telecommunication equipment installed in customer's premises to overvoltages and overcurrents*

Annex Q (informative)

Bibliography

IEC 60127 (all parts), *Miniature fuses*

IEC 60269-2-1:1998, *Low voltage fuses – Part 2-1: Supplementary requirements for fuses for use by authorized persons (fuses mainly for industrial application) – Sections I to V: Examples of types of standardized fuses*

IEC 60364-7-707:1984, *Electrical installations of buildings – Part 7: Requirements for special installations or locations – Section 707: Earthing requirements for the installation of data processing equipment*

IEC 60410:1973, *Sampling plans and procedures for inspection by attributes*

IEC 60529:1989, *Degrees of protection provided by enclosures (IP Code)*

IEC/TR 60664-4:1997, *Insulation coordination for equipment within low voltage systems – Part 4: Considerations of high-frequency voltage stress*

IEC 61032:1997, *Test probes to verify protection by enclosures*

IEC 61140:1997, *Protection against electric shock – Common aspects for installation and equipment*

IEC Guide 112:2000, *Guide on the safety of multimedia equipment*

ISO 2859-1:1999, *Sampling procedures for inspection by attributes – Part 1: Sampling schemes indexed by acceptance quality limit (AQL) for lot-by-lot inspection*

ISO 4046:1978, *Paper, board, pulp and related terms – Vocabulary*

CFR 47, Part 68: *Code of Federal Regulations (USA) Part 68: Connection of terminal equipment to the telephone network (commonly referred to as "FCC Rules, part 68")*

CIE Publication 63:1984, *The spectroradiometric measurement of light sources*

ICRP 15:1969, *Protection against ionising radiation from external sources*, published for the International Commission on Radiological Protection by Pergamon Press

ITU-T Recommendation K.11:1993, *Principles of protection against overvoltages and overcurrents*

ITU-T Recommendation K.27:1996, *Bonding configurations and earthing inside a telecommunication building*

ITU-T Recommendation K.31:1993, *Bonding configurations and earthing of telecommunication installations inside a subscriber's building*

Annex R (informative)

Examples of requirements for quality control programmes

NOTE This annex gives examples of requirements for quality control programmes as specified in 2.10.6 for minimum separation distances for coated printed boards and in 2.10.3 and clause G.2 for reduced CLEARANCES.

R.1 Minimum separation distances for unpopulated coated printed boards (see 2.10.6)

A manufacturer wishing to use the reduced separation distances permitted by 2.10.6, table 2N, shall implement a quality control programme for those features of the boards which are listed in table R.1. This programme shall include specific quality controls for the tools and materials which affect conductor spacing, adequate inspection of pattern and spacing, cleanliness, coating thickness, electrical tests for short circuits, insulation resistance and electric withstand voltage.

The manufacturer shall also identify and plan the protection and, where applicable, installation processes which directly affect quality and shall ensure that these processes are carried out under controlled conditions. Controlled conditions shall include the following:

- documented work instructions defining process, equipment, environment and manner of production where the absence of such instructions would adversely affect quality, use of suitable production and installation equipment, suitable working environment, compliance with reference standards, specifications and quality plans;
- monitoring and control of suitable processes and product characteristics during production and installation in the equipment;
- criteria for workmanship stipulated to the extent necessary in written specifications or by means of representative samples;
- records maintained for qualified processes, equipment and personnel as appropriate.

Table R.1 provides the sampling plan for attributes and tests necessary to conform to the requirements of 2.10.6. The number of samples of production boards shall be based on IEC 60410 or ISO 2859-1 or equivalent national standards.

Table R.1 – Rules for sampling and inspection – coated printed boards

Tests	BASIC INSULATION	SUPPLEMENTARY INSULATION	REINFORCED INSULATION
Spacing mm ¹⁾	Sampling S2 AQL 1,0	Sampling S2 AQL 1,0	Sampling S2 AQL 1,0
Electric strength test ²⁾	Sampling S2 AQL 2,5	Sampling S2 AQL 2,5	ROUTINE TEST; one failure requires evaluation for cause
Abrasion resistance	Sampling S1 AQL 2,5	Sampling S1 AQL 2,5	Sampling S1 AQL 2,5
Thermal ageing ³⁾	Sampling S3 AQL 4	Sampling S3 AQL 4	Sampling S3 AQL 4
Thermal cycling ³⁾	Sampling S1 AQL 1,5	Sampling S1 AQL 1,5	Sampling S1 AQL 1,5
Insulation resistance ⁴⁾	Sampling S2 AQL 2,5	Sampling S2 AQL 2,5	Sampling S2 AQL 2,5
Visual inspection of coating ⁵⁾	ROUTINE TEST	ROUTINE TEST	ROUTINE TEST
<p>1) To minimize test and inspection time, it is permitted to replace measurement of separation distances by measurement of breakdown voltage. Initially the breakdown voltage is established for 10 uncoated boards for which the correct spacing measurements have been confirmed. The breakdown voltage of subsequent uncoated production boards is then checked against a lower limit equal to the minimum breakdown voltage for the 10 initial boards minus 100 V. If breakdown occurs at this lower limit, a board is considered a failure unless direct measurement of the spacing conforms with the requirement.</p> <p>2) The electric strength test shall be conducted according to 5.2.2 except that the duration shall be 1 s to 5 s.</p> <p>3) The thermal ageing and thermal cycling tests shall be done whenever the type of coating material, printed board material, or the process is changed. It is recommended that it should be done at least once a year.</p> <p>4) The insulation resistance shall be not less than 1 000 MΩ.</p> <p>5) Visual inspection without optical magnification or automated optical inspection with equivalent resolution shall show no cracks, no bubbles, no pinholes, or detachment of the coating in the area of reduced spacings. Any such defects shall be reason for rejection of the printed board.</p>			

R.2 Reduced clearances (see 2.10.3)

A manufacturer wishing to use reduced CLEARANCES permitted by 2.10.3, tables 2H, 2J, 2K and clause G.2, shall implement a quality control programme for those features of the construction listed in table R.2. This programme shall include specific quality controls for the tools and materials which affect CLEARANCES.

The manufacturer shall also identify and plan the protection and, where applicable, installation processes which directly affect quality and shall ensure that these processes are carried out under controlled conditions. Controlled conditions shall include the following:

- documented work instructions defining process, equipment, environment, and manner of production where the absence of such instructions would adversely affect quality, suitable working environment, compliance with reference standards or specifications and quality plans;

- monitoring and control of suitable processes and product characteristics during production and installation in the equipment;
- criteria for workmanship stipulated to the extent necessary in written specifications or by means of representative samples;
- records maintained for qualified processes, equipment and personnel as appropriate.

Table R.2 provides the sampling plan for attributes and tests necessary to conform to the requirements of 2.10.3. The number of samples of production parts or assemblies shall be based on IEC 60410 or ISO 2859-1 or equivalent national standards.

Table R.2 – Rules for sampling and inspection – reduced clearances

Tests	BASIC INSULATION	SUPPLEMENTARY INSULATION	REINFORCED INSULATION
CLEARANCE ¹⁾	Sampling S2 AQL 4	Sampling S2 AQL 4	Sampling S2 AQL 4
Electric strength test ²⁾	No test	No test	ROUTINE TEST; one failure requires evaluation for cause
<p>¹⁾ To minimize test and inspection time, it is permitted to replace measurement of CLEARANCES by measurement of breakdown voltage. Initially the breakdown voltage is established for 10 samples for which the correct CLEARANCE measurements have been confirmed. The breakdown voltage of subsequent parts or assemblies is then checked against a lower limit equal to the minimum breakdown voltage of the initial 10 samples minus 100 V. If breakdown occurs at this lower limit, a part or assembly is considered a failure unless direct measurement of the CLEARANCE conforms to the requirement.</p> <p>²⁾ The electric strength test for REINFORCED INSULATION shall consist of one of the following alternatives:</p> <ul style="list-style-type: none"> – six impulses of alternating polarity, using a 1,2/50 µs impulse with a magnitude equal to the peak of the test voltage in table 5B (see 5.2.2); – a three cycle pulse of a.c. power frequency with a magnitude equal to the test voltage in table 5B (see 5.2.2); – six impulses of alternating polarity, using 10 ms d.c. impulses with a magnitude equal to the peak of the test voltage in table 5B (see 5.2.2). 			

Annex S (informative)

Procedure for impulse testing (see 6.2.2.3)

S.1 Test equipment

Impulse generator according to annex N.

Storage oscilloscope with a bandwidth of a few MHz.

High voltage probe with compensating elements.

S.2 Test procedure

Apply the required number of impulses to the equipment under test and record the waveform patterns.

Examples are given in clause S.3 to assist in judging whether or not a surge suppressor has operated or insulation has broken down.

S.3 Examples of waveforms during impulse testing

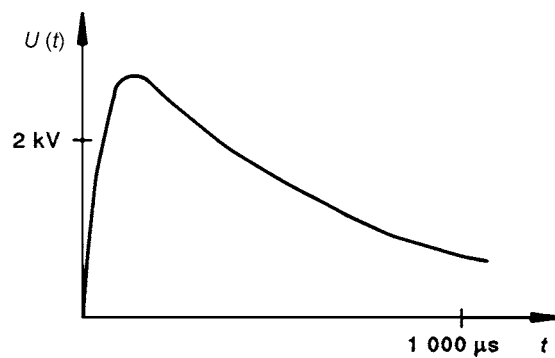

IEC 1701/01

Consecutive impulses are identical in their waveforms.

Figure S.1 – Waveform on insulation without surge suppressors and no breakdown

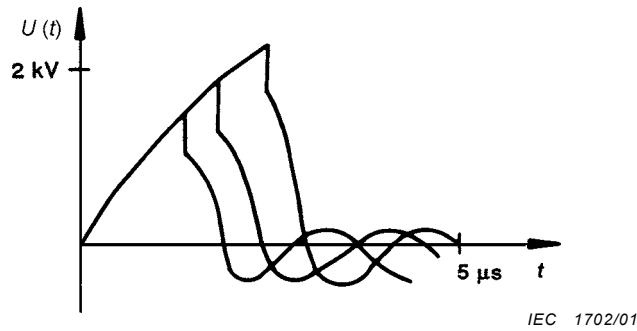

Consecutive impulses are not identical in their waveforms. The pulse shape changes from pulse to pulse until a stable resistance path through the insulation is established. Breakdown can be seen clearly on the shape of the pulse voltage oscillogram.

Figure S.2 – Waveforms on insulation during breakdown without surge suppressors

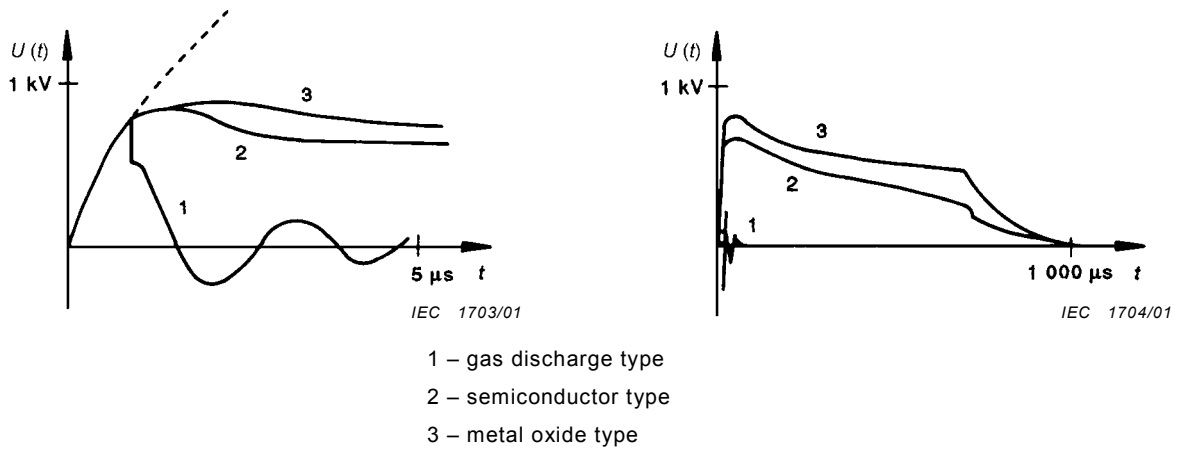

Consecutive impulses are identical in their waveforms.

Figure S.3 – Waveforms on insulation with surge suppressors in operation

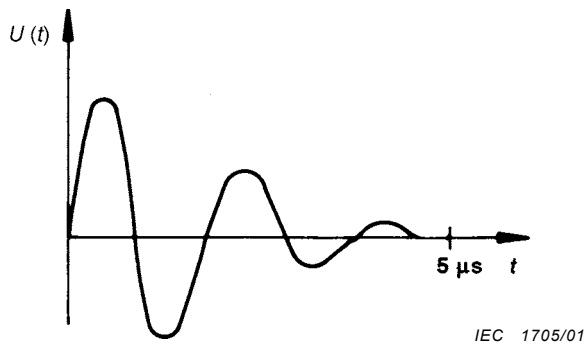

Figure S.4 – Waveform on short-circuited surge suppressor and insulation

Annex T (informative)

Guidance on protection against ingress of water (see 1.1.2)

When the intended application is such that ingress of water is possible, an appropriate degree of protection other than IPX0 should be selected by the manufacturer from IEC 60529:1989, an extract from which is included in this annex.

Additional design features should then be included to ensure that ingress of water does not affect insulation.

IEC 60529:1989 gives test conditions for each degree of protection other than IPX0. The conditions appropriate to the selected degree of protection should be applied to the equipment, immediately followed by an electric strength test as specified in 5.2.2 on any insulation which may have become wet, and inspection should show that water has not created a risk of personal injury or fire. In particular, there should be no trace of water on insulation that is not designed to operate when wet.

If the equipment is provided with drain holes, inspection should show that any water which enters does not accumulate and that it drains away without affecting compliance.

If the equipment is not provided with drain holes, account should be taken of the possibility of build-up of water.

Where equipment is only partly exposed to water, for example, when it is to be installed through an opening in an outside wall, only the exposed parts should be subjected to the IEC 60529:1989 test conditions. For these tests, such equipment should be installed in an appropriate test assembly, simulating actual conditions of installation according to the installation instructions, including the use of a kit of sealing parts where required.

It should not be possible to remove, without the aid of a TOOL, parts which ensure the required degree of protection against ingress of water.

The information in table T.1 is extracted from IEC 60529:1989.

Table T.1 – Extract from IEC 60529:1989

Second characteristic numeral	Degree of protection	
	Brief description	Definition
0	Non-protected	–
1	Protected against vertically falling water drops	Vertically falling water drops shall have no harmful effects
2	Protected against vertically falling water drops when enclosure tilted up to 15°	Vertically falling drops shall have no harmful effects when the enclosure is tilted at any angle up to 15° on either side of the vertical
3	Protected against spraying water	Water sprayed at an angle up to 60° on either side of the vertical shall have no harmful effects
4	Protected against splashing water	Water splashed against the enclosure from any direction shall have no harmful effects
5	Protected against water jets	Water projected in jets against the enclosure from any direction shall have no harmful effects
6	Protected against powerful water jets	Water projected in powerful jets against the enclosure from any direction shall have no harmful effects
7	Protected against the effects of temporary immersion in water	Ingress of water in quantities causing harmful effects shall not be possible when the enclosure is temporarily immersed in water under standardized conditions of pressure and time
8	Protected against the effects of continuous immersion in water	Ingress of water in quantities causing harmful effects shall not be possible when the enclosure is continuously immersed in water under conditions which shall be agreed between the manufacturer and user but which are more severe than for numeral 7

Annex U (normative)

Insulated winding wires for use without interleaved insulation (see 2.10.5.4)

This annex specifies winding wire whose insulation may be used to provide BASIC INSULATION, SUPPLEMENTARY INSULATION, DOUBLE INSULATION or REINFORCED INSULATION in wound components without interleaved insulation.

This annex covers round winding wires having diameters between 0,05 mm and 5,00 mm.

U.1 Wire construction

If the wire is insulated with two or more spirally wrapped layers of tape, the overlap of layers shall be adequate to ensure continued overlap during manufacture of the wound component. The layers of spirally wrapped wire insulation shall be sufficiently secured to maintain the amount of overlap.

U.2 Type tests

The wire shall pass the tests of U.2.1 to U.2.4, carried out at a temperature between 15 °C and 35 °C and a relative humidity between 45 % and 75 %, unless specified otherwise.

U.2.1 Electric strength

The test sample is prepared according to IEC 60851-5:1996, 4.4.1 (for a twisted pair). The sample is then subjected to the test of 5.2.2 of this standard. The test voltage shall be not less than twice the appropriate voltage in table 5B (see 5.2.2) of this standard, with a minimum of:

- 3 000 V for BASIC INSULATION or SUPPLEMENTARY INSULATION; or
- 6 000 V for REINFORCED INSULATION.

U.2.2 Flexibility and adherence

Test 8 of IEC 60851-3:1996, 5.1.1, using the mandrel diameters of table U.1. The test sample is then examined in accordance with IEC 60851-3:1996, 5.1.1.4, followed by the test of 5.2.2 of this standard except that the test voltage is applied between the wire and the mandrel. The test voltage shall be not less than the appropriate voltage in table 5B (see 5.2.2) of this standard, with a minimum of:

- 1 500 V for BASIC INSULATION or SUPPLEMENTARY INSULATION; or
- 3 000 V for REINFORCED INSULATION.

Table U.1 – Mandrel diameter

Nominal conductor diameter mm	Mandrel diameter mm ± 0,2 mm
0,05 – 0,34	4,0
0,35 – 0,49	6,0
0,50 – 0,74	8,0
0,75 – 2,49	10,0
2,50 – 5,00	four times the conductor diameter ¹⁾
¹⁾ In accordance with IEC 60317-43.	

The tension to be applied to the wire during winding on the mandrel is calculated from the wire diameter to be equivalent to 118 MPa ± 10 % (118 N/mm² ± 10 %).

U.2.3 Heat shock

Test 9 of IEC 60851-6:1996, followed by the electric strength test of 5.2.2 of this standard except that the test voltage is applied between the wire and the mandrel. The voltage shall be not less than the appropriate voltage in table 5B (see 5.2.2) of this standard, with a minimum of:

- 1 500 V for BASIC INSULATION or SUPPLEMENTARY INSULATION; or
- 3 000 V for REINFORCED INSULATION.

The oven temperature is the relevant temperature for the thermal class of insulation in table U.2.

The mandrel diameter and tension applied to the wire during winding on the mandrel are as in U.2.2.

The electric strength test is conducted at room temperature after removal from the oven.

Table U.2 – Oven temperature

Thermal class	A (105)	E (120)	B (130)	F (155)	H (180)
Oven temperature °C ± 5 °C	200	215	225	240	260

U.2.4 Retention of electric strength after bending

Five samples are prepared as in U.2.2 above and tested as follows. Each sample is removed from the mandrel, placed in a container and positioned so that it can be surrounded by at least 5 mm of metal shot. The ends of the conductor in the sample shall be sufficiently long to avoid flash over. The shot shall be not more than 2 mm in diameter and shall consist of balls of stainless steel, nickel or nickel plated iron. The shot is gently poured into the container until the sample under test is covered by at least 5 mm of shot. The shot shall be cleaned periodically with a suitable solvent (for example, 1,1,1-trichloroethane).

NOTE The above test procedure is reproduced from 4.6.1 c) of IEC 60851-5:1988 (second edition including amendment 1), now withdrawn. It is not included in the third edition of that standard.

The test voltage shall be not less than the appropriate test voltage in table 5B (see 5.2.2) of this standard, with a minimum of:

- 1 500 V for BASIC INSULATION or SUPPLEMENTARY INSULATION; or
- 3 000 V for REINFORCED INSULATION.

The test voltage is applied between the shot and the conductor.

The mandrel diameter and tension applied to the wire during winding on the mandrel are as in U.2.2.

U.3 Tests during manufacture

The wire shall be subjected by the wire manufacturer to electric strength tests during manufacture as specified in U.3.1 and U.3.2.

U.3.1 Routine testing

The test voltage for ROUTINE TESTING shall be the appropriate voltage in table 5B (see 5.2.2) of this standard, with a minimum of:

- 1 500 V r.m.s. or 2 100 V peak for BASIC INSULATION or SUPPLEMENTARY INSULATION; or
- 3 000 V r.m.s. or 4 200 V peak for REINFORCED INSULATION.

U.3.2 Sampling tests

Twisted pair samples shall be tested in accordance with IEC 60851-5:1996, 4.4.1. The minimum breakdown voltage shall be twice the appropriate voltage in table 5B (see 5.2.2) of this standard, with a minimum of:

- 3 000 V r.m.s. or 4 200 V peak for BASIC INSULATION or SUPPLEMENTARY INSULATION; or
- 6 000 V r.m.s. or 8 400 V peak for REINFORCED INSULATION.

Annex V (normative)

AC power distribution systems (see 1.6.1)

V.1 Introduction

In IEC 60364-3, a.c. power distribution systems are classified TN, TT and IT, depending on the arrangement of current-carrying conductors and the method of earthing. The classes and codes are explained in this annex. Some examples of each class are given in the figures; other configurations also exist.

In the figures:

- in most cases, the power distribution systems apply for single-phase and three-phase equipment, but for simplicity, only single-phase equipment is illustrated;
- the power sources may be transformer secondaries, motor-driven generators or uninterruptible power distribution systems;
- for transformers within a user's building, some of the figures apply, and the building boundary represents a floor of the building;
- some power distribution systems are earthed at additional points, for example, at the power entry points of users' buildings (see IEC 60364-4-41, 413.1.3.1, note 1).

The following types of equipment connection are taken into account; the numbers of wires mentioned do not include conductors used exclusively for earthing.

Single-phase, 2 wire

Single-phase, 3 wire

Two-phase, 3 wire

Three-phase, 3 wire

Three-phase, 4 wire

The system codes used have the following meaning:

- First letter: relationship of the power distribution system to earth;
 - T means direct connection of one pole to earth,
 - I means system isolated from earth, or one point connected to earth through an impedance.
- Second letter: earthing of the equipment;
 - T means direct electrical connection of the equipment to earth, independently of the earthing of any point of the power distribution system,
 - N means direct electrical connection of the equipment to the earthed point of the power distribution system (in a.c. systems, the earthed point of the power distribution system is normally the neutral point or, if a neutral point is not available, a phase conductor).

- Subsequent letters if any: arrangement of neutral and protective conductors;
 - S means the protective function is provided by a conductor separate from the neutral or from the earthed line (or in a.c. systems, earthed phase) conductor,
 - C means the neutral and protective functions are combined in a single conductor (PEN conductor).

V.2 TN power distribution systems

TN power distribution systems are directly earthed, the parts of the equipment required to be earthed being connected by PROTECTIVE EARTHING CONDUCTORS. Three types of TN power distribution systems are considered:

- TN-S power distribution system, in which a separate protective conductor is used through-out the system;
- TN-C-S power distribution system, in which neutral and protective functions are combined in a single conductor in part of the system;
- TN-C power distribution system, in which neutral and protective functions are combined in a single conductor throughout the system.

Some TN power distribution systems are supplied from a secondary winding of a transformer that has an earthed centre tap (neutral). Where the two phase conductors and the neutral conductor are available, these systems are commonly known as "single-phase, 3-wire power distribution systems".

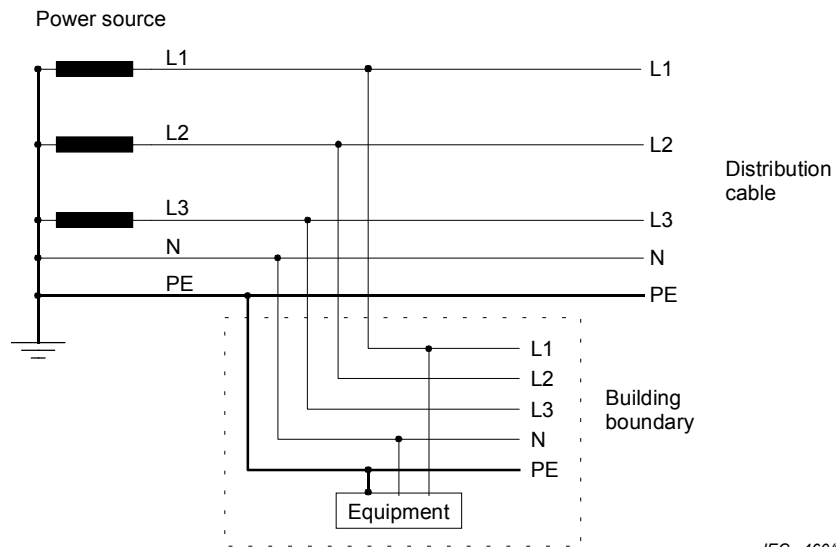

IEC 460/99

Separate neutral and protective conductors

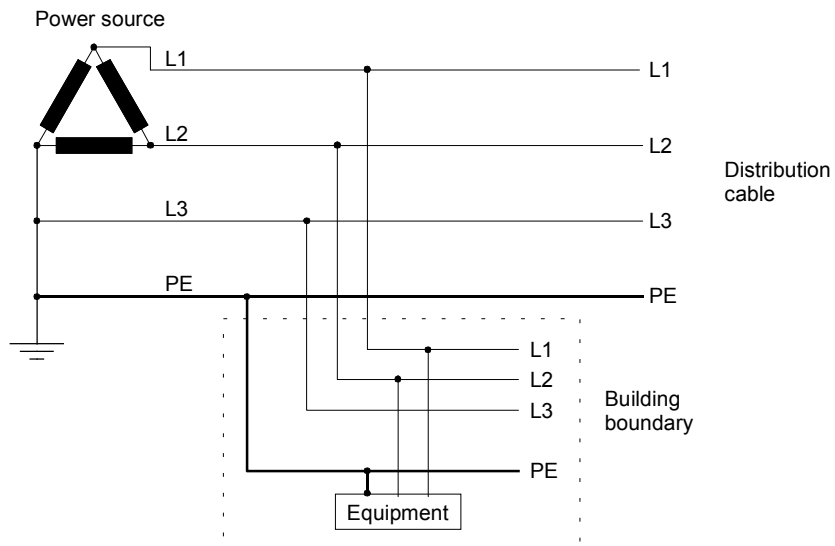

IEC 461/99

Earthed line conductor

Figure V.1 – Examples of TN-S power distribution systems

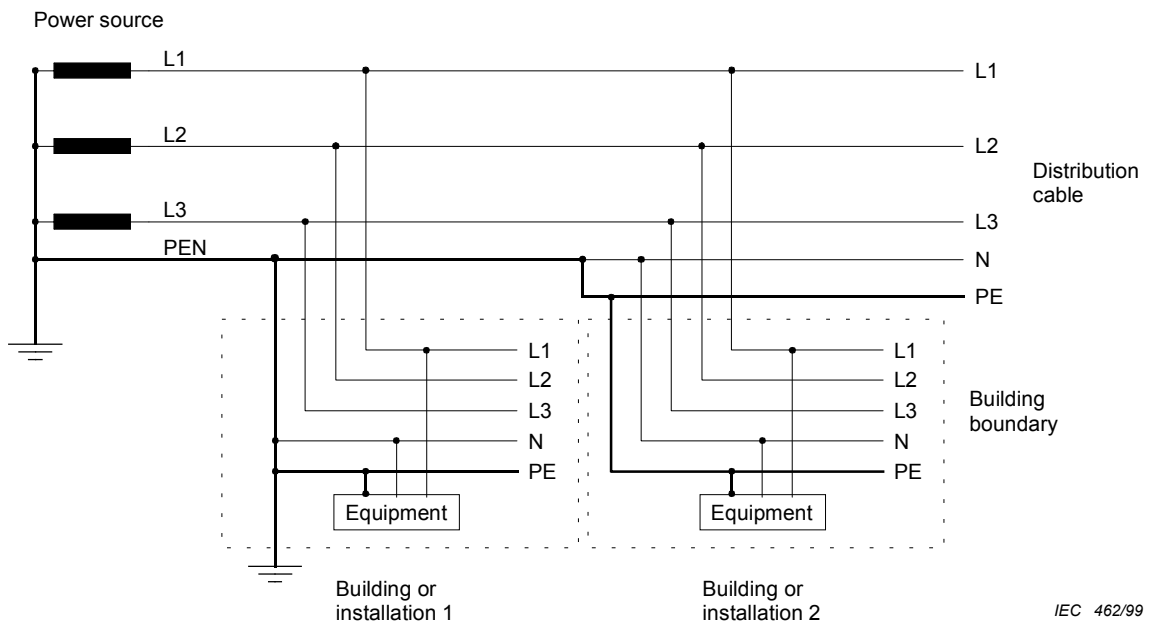

Neutral and protective functions combined in a single conductor in part of the system (PEN)

NOTE The point at which the PEN conductor is separated into protective earth and neutral conductors may be at the building entrance or at distribution panels within the building.

Figure V.2 – Example of TN-C-S power distribution system

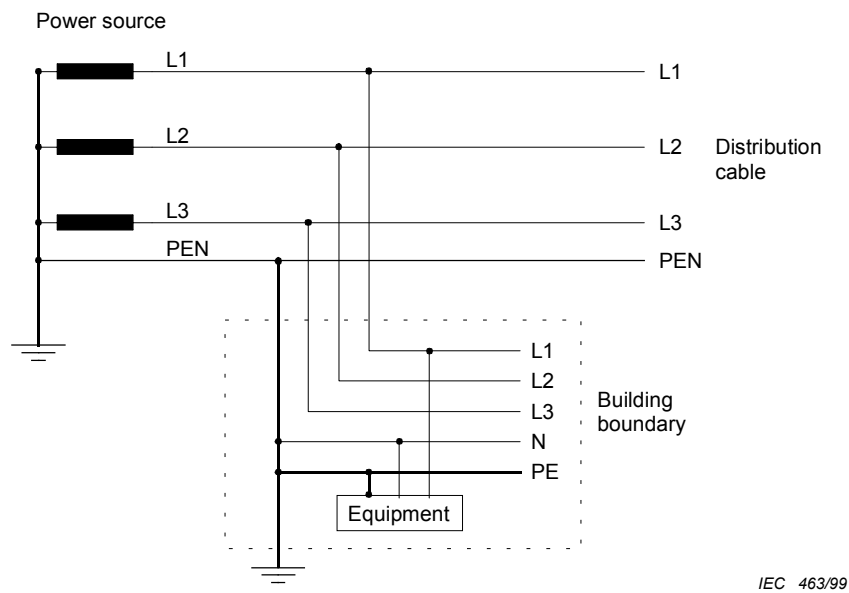

Neutral and protective functions combined in one conductor (PEN)

Figure V.3 – Example of TN-C power distribution system

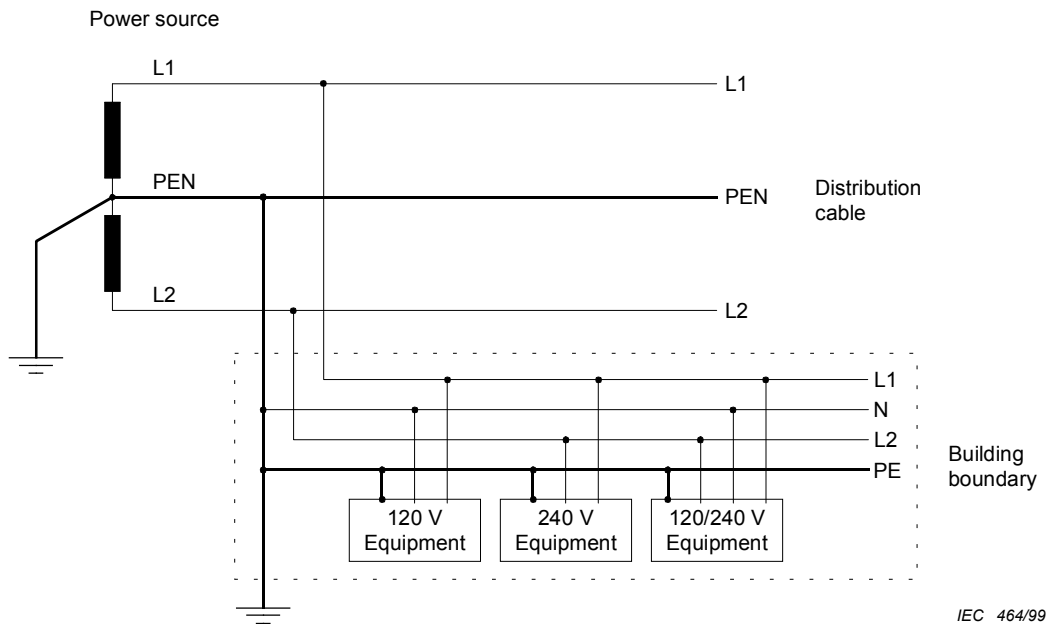

Protective and neutral functions combined in one conductor (PEN)
This system is widely used in North America at 120/240 V.

Figure V.4 – Example of single-phase, 3-wire TN-C power distribution system

V.3 TT power distribution systems

TT power distribution systems have one point directly earthed, the parts of the equipment required to be earthed being connected at the user’s premises to earth electrodes that are electrically independent of the earth electrodes of the power distribution system.

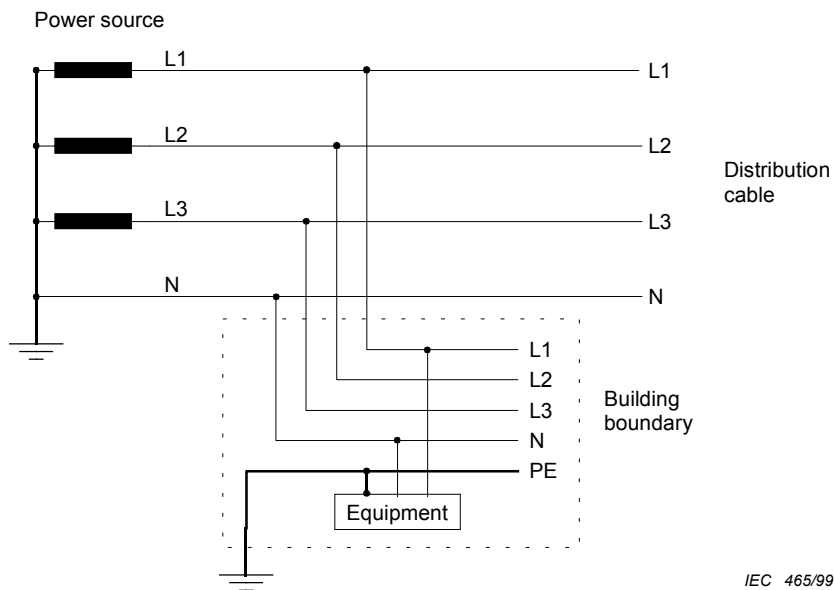

Earthed neutral and independent earthing of equipment

Figure V.5 – Example of three line and neutral TT power distribution system

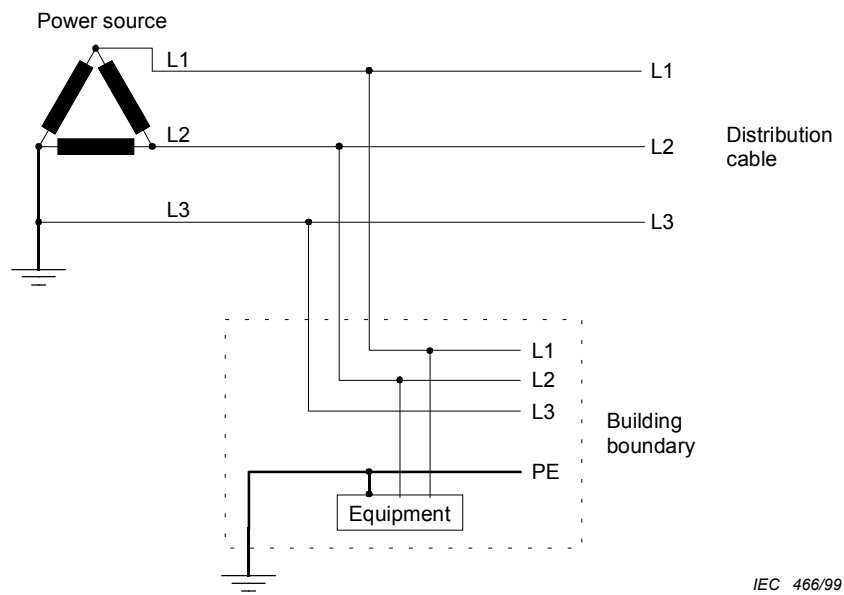

Earthed line and independent earthing of equipment

Figure V.6 – Example of three line TT power distribution system

V.4 IT power distribution systems

IT power distribution systems are isolated from earth, except that one point may be connected to earth through an impedance or a voltage limiter. The parts of the equipment required to be earthed are connected to earth electrodes at the user’s premises.

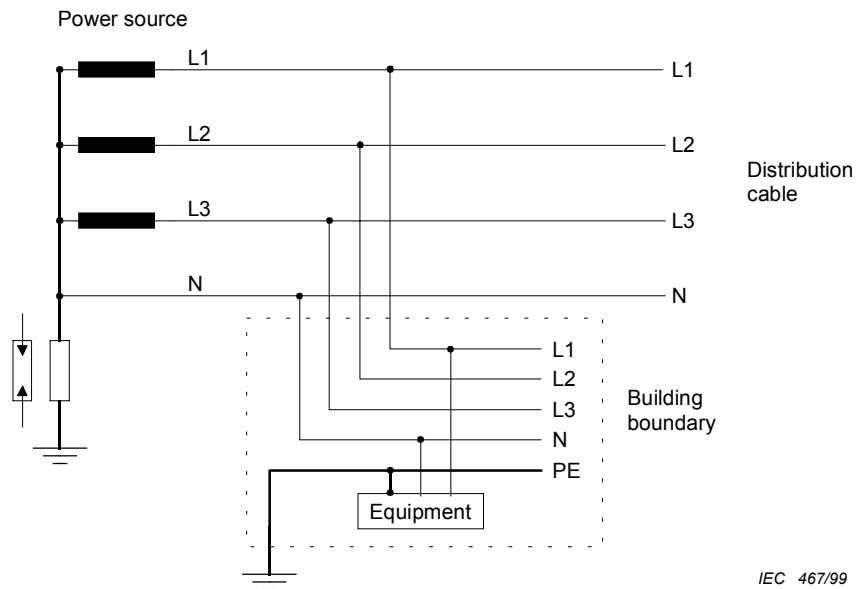

The neutral may be connected to earth through an impedance or voltage limiter, or isolated from earth.

This system is widely used isolated from earth, in some installations in France, with impedance to earth, at 230/400 V, and in Norway, with voltage limiter, neutral not distributed, at 230 V line-to-line.

Figure V.7 – Example of three line (and neutral) IT power distribution system

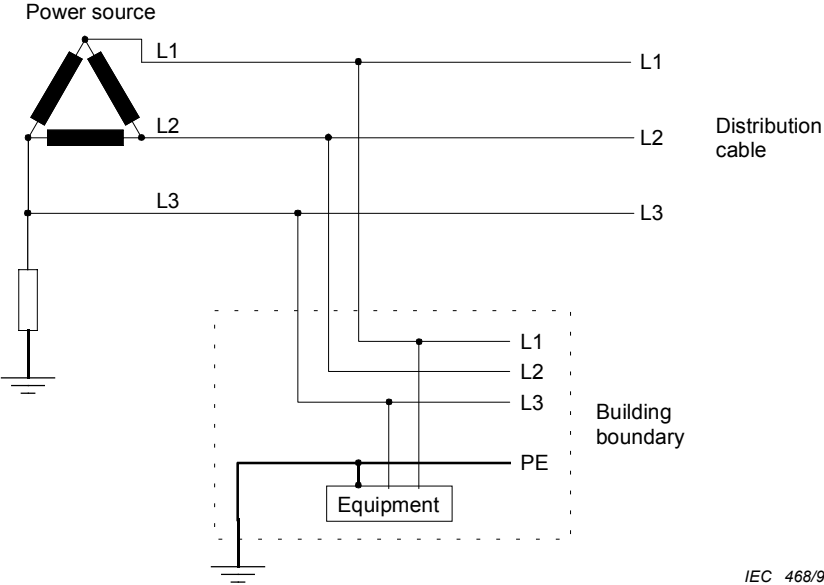

IEC 468/99

The system may be isolated from earth

Figure V.8 – Example of three line IT power distribution system

Annex W (informative)

Summation of touch currents

This annex explains the background to the requirements and tests in 5.1.8.2.

W.1 Touch current from electronic circuits

There are two quite different mechanisms that determine the current through a human body that touches an electronic circuit (or power bus), depending on whether or not the circuit is earthed. This distinction between earthed and unearthed (floating) circuits is not the same as between CLASS I EQUIPMENT and CLASS II EQUIPMENT. Floating circuits can exist in CLASS I EQUIPMENT and earthed circuits in CLASS II EQUIPMENT. Floating circuits are commonly, but not exclusively, used in telecommunication equipment and earthed circuits in data processing equipment, but not exclusively.

In order to consider the worst case, it will be assumed in this annex that TELECOMMUNICATION NETWORKS are floating and that the AC MAINS SUPPLY and human bodies (SERVICE PERSONS or OPERATORS) are earthed. It should be noted that a SERVICE PERSON can touch some parts that are not OPERATOR-accessible. An "earthed" circuit means that the circuit is either directly earthed or in some way referenced to earth so that its potential with respect to earth is fixed.

W.1.1 Floating circuits

If the circuit is not earthed, the current (I_C) through the human body is "leakage" through stray or added capacitance (C) across the insulation in the mains transformer (see figure W.1).

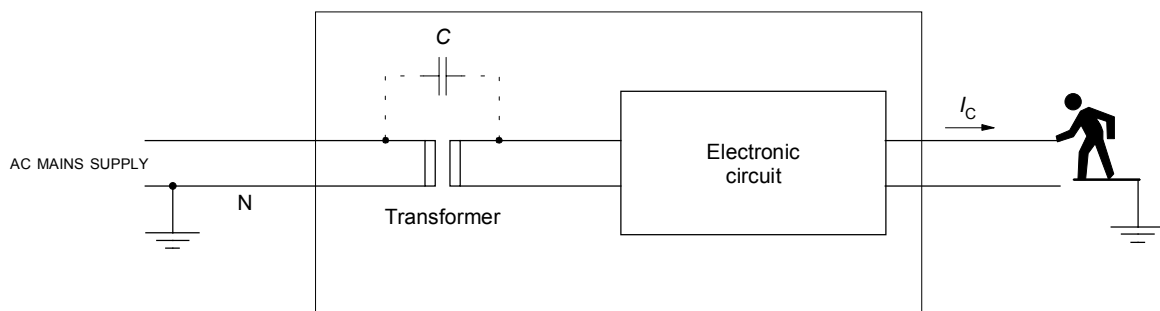

IEC 469/99

Figure W.1 – Touch current from a floating circuit

This current comes from a relatively high voltage, high impedance source, and its value is largely unaffected by the operating voltage on the electronic circuit. In this standard, the body current (I_C) is limited by applying a test using the measuring instrument in annex D, which roughly simulates a human body.

W.1.2 Earthed circuits

If the electronic circuit is earthed, the current through the human body (I_V) is due to the operating voltage (V) of the circuit, which is a source of low impedance compared with the body (see figure W.2). Any leakage current from the mains transformer (see W.1.1), will be conducted to earth and will not pass through the body.

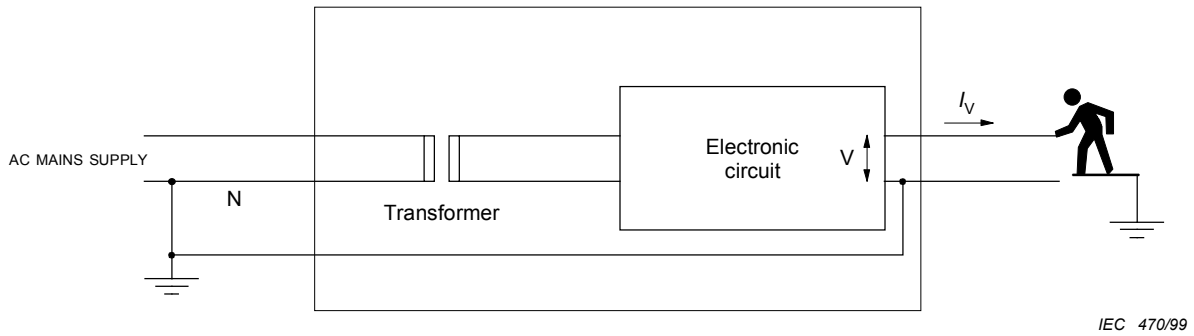

Figure W.2 – Touch current from an earthed circuit

In this standard, the body current (I_V) is limited by specifying maximum voltage values for the accessible circuit, which shall be an SELV CIRCUIT or (with restricted accessibility) a TNV CIRCUIT.

W.2 Interconnection of several equipments

It is a characteristic of information technology equipment, especially in telecommunication applications, that many equipments may be connected to a single central equipment in a "star" topology. An example is telephone extensions or data terminals connected to a PABX, which may have tens or hundreds of ports. This example is used in the following description (see figure W.3).

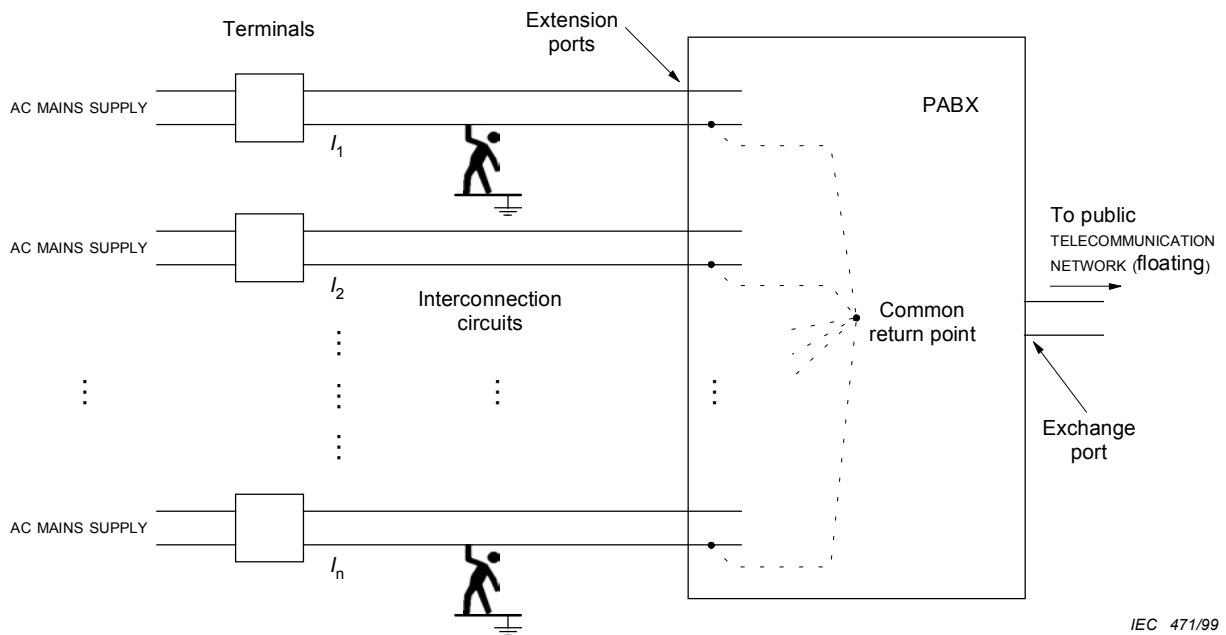

Figure W.3 – Summation of touch currents in a PABX

Each terminal equipment can deliver current to a human body touching the interconnecting circuit (I_1 , I_2 , etc.), added to any current coming from the PABX port circuitry. If several circuits are connected to a common point, their individual TOUCH CURRENTS will add together, and this represents a possible risk to an earthed human body that touches the interconnection circuit.

Various ways of avoiding this risk are considered in the following subclauses.

W.2.1 Isolation

Isolate all interconnection circuits from each other and from earth, and limit I_1 , I_2 , etc., to a safe value as described in W.1.1. This implies either the use in the PABX of a separate power supply for each port, or the provision of an individual line (signal) transformer for each port. Such solutions may not be cost effective.

W.2.2 Common return, isolated from earth

Connect all interconnection circuits to a common return point that is isolated from earth. (Such connections to a common point may in any case be necessary for functional reasons.) In this case the total current from all interconnection circuits will pass through an earthed human body that touches either wire of any interconnection circuit. This current can only be limited by controlling the values I_1 , I_2 ... I_n in relation to the number of ports on the PABX. However, the value of the total current will probably be less than $I_1 + I_2 + \dots + I_n$ due to harmonic and other effects.

W.2.3 Common return, connected to protective earth

Connect all interconnection circuits to a common return point and connect that point to protective earth. The situation described in W.1.2 applies regardless of the number of ports. Since safety depends on the presence of the earth connection, it may be necessary to use high-integrity earthing arrangements, depending on the maximum value of the total current that could flow.

Annex X (informative)

Maximum heating effect in transformer tests (see clause C.1)

Clause C.1 requires transformers to be loaded in such a way as to give the maximum heating effect. In this annex examples are given of various methods of producing this condition. Other methods are possible and compliance with clause C.1 is not restricted to these examples.

X.1 Determination of maximum input current

The value of the input current at rated load is established. This is I_r , see step A of table X.1. The value may be established by test or from manufacturer's data.

A load is applied to the output winding or to the output of the switch mode power supply unit while measuring the input current. The load is adjusted as quickly as possible to provide the maximum value of input current which can be sustained for approximately 10 s of operation. This is I_m , see step B of table X.1. The test is then repeated according to step C and, if necessary, steps D to J of table X.1. The input current at each step is then noted and maintained until either:

- the temperature of the transformer stabilizes without the operation of any component or protective device (inherent protection) in which case no further testing is conducted; or*
- a component or protective device operates, in which case the winding temperature is noted immediately and the test of clause X.2 is then conducted depending on the type of protection.*

If any component or protective device operates within 10 s after the application of the primary voltage, I_m is the value recorded just before the component or protective device operates.

In conducting the tests described in steps C to J of table X.1, the variable load is adjusted to the required value as quickly as possible and readjusted, if necessary, 1 min after application of the primary voltage. The sequence of steps C to J may be reversed.

Table X.1 – Test steps

Steps	Input current of the transformer or switch mode power supply unit
A	Input current at rated load = I_r
B	Maximum value of input current after 10 s of operation = I_m
C	$I_r + 0,75 (I_m - I_r)$
D	$I_r + 0,50 (I_m - I_r)$
E	$I_r + 0,25 (I_m - I_r)$
F	$I_r + 0,20 (I_m - I_r)$
G	$I_r + 0,15 (I_m - I_r)$
H	$I_r + 0,10 (I_m - I_r)$
J	$I_r + 0,05 (I_m - I_r)$

X.2 Overload test procedure

Electronic protection:

If the test of clause X.1 results in condition X.1 b), the current is either reduced in steps of 5 % from this condition or increased in steps of 5 % from the rated load to find the maximum overload at which the temperature stabilizes without the operation of any electronic protection.

Thermal protection:

An overload is applied such that the operating temperature remains a few degrees below the rated opening temperature of the thermal protection.

Overcurrent protection:

An overload is applied such that a current flows in accordance with the current versus time trip curves of the overcurrent protective device.

Annex Y (normative)

Ultraviolet light conditioning test (see 4.3.13.3)

Y.1 Test apparatus

Samples are exposed to ultraviolet light by using one of the following apparatus:

- a twin enclosed carbon-arc, (see clause Y.3), with continuous exposure. The test apparatus shall operate with a black-panel temperature of $63\text{ °C} \pm 3\text{ °C}$ in a relative humidity of $50\% \pm 5\%$; or
- a xenon-arc (see clause Y.4), with continuous exposure. The test apparatus shall operate with a 6 500 W, water-cooled xenon-arc lamp, a spectral irradiance of $0,35\text{ W/m}^2$ at 340 nm, a black-panel temperature of $63\text{ °C} \pm 3\text{ °C}$ in a relative humidity of $50\% \pm 5\%$.

Y.2 Mounting of test samples

The samples are mounted vertically on the inside of the cylinder of the light exposure apparatus, with the widest portion of the samples facing the arcs. They are mounted so that they do not touch each other.

Y.3 Carbon-arc light-exposure apparatus

The apparatus described in ISO 4892-4, or equivalent, is used in accordance with the procedures given in ISO 4892-1 and ISO 4892-4 using a type 1 filter, without water spray.

Y.4 Xenon-arc light-exposure apparatus

The apparatus described in ISO 4892-2, or equivalent, is used in accordance with the procedures given in ISO 4892-1 and ISO 4892-2 using method A, without water spray.

NOTE The wording "without water spray" indicates that the samples are not sprayed with water during the test. This should not be confused with water cooling which is necessary for operation of the apparatus.

INDEX

This index is for information only and does not purport to be a complete guide to the use of this standard. The inclusion or omission of items in the index does not imply any particular importance.

Location references are clause or sub-clause numbers or annex letters.

Table numbers and figure numbers are linked to the clause or annex in which they are found. For example, table 2A is the first table in clause 2, and figure F.2 is the second figure in annex F.

Principal references are printed **Bold**.

If a term is defined in 1.2 of this standard, its definition is indicated in the index by an asterisk,

for example: **RATED VOLTAGE** 1.2.1.1*.

This index is also used to explain some acronyms, for example: **EUT** equipment under test.

Country notes are listed, but the contents are not indexed.

In this edition, several subclause numbers are new, deleted or changed. On the next page is a list of these changes, which have been taken into account in the Index.

Numbering Changes Table

Third edition number	Action	New number
Subclauses		
	new	1.2.8.2
1.2.8.2 - 1.2.8.12	renumbered	1.2.8.3 - 1.2.8.13
	new	1.4.15
	new	1.5.7.1
1.5.7.1		1.5.7.2
1.5.7.2		1.5.7.3
1.5.7.3		1.5.7.4
	new	1.7.7.3
	new	2.6.3.1
2.6.3.1		2.6.3.2
2.6.3.2		2.6.3.3
2.6.3.3		2.6.3.4
	new	2.6.4.1
2.6.4.1		2.6.4.2
2.6.4.2		2.6.4.3
2.9.3	deleted	
2.9.4	deleted	
2.9.5		2.9.3
3.2.1		3.2.1.1
	new	3.2.1.2
3.2.5		3.2.5.1
	new	3.2.5.2
4.3.13		4.3.13.1, 2, 5 and 6
	new	4.3.13.3
	new	4.3.13.4
	new	clause 7
A.3, A.4	deleted	
A.5		A.3
A.6 - A.10	deleted	
N		N.1 and N.2
Figures		
4G	deleted	
A1 - A4	deleted	
	new	N.2
Tables		
	new	4A
4A		4B
4B		4C
4C		4D
A1	deleted	

A

abnormal conditions	0.1, 1.3.2	sharp edge	4.3.1
heating elements	4.3.7	TELECOMMUNICATION NETWORK	6.2.1
overload protection	5.3.1, 5.3.3	terminals in supply wiring space	3.2.9
sequence of testing	1.4.3	TNV CIRCUIT <i>see</i> TNV CIRCUIT, accessibility	
simulated	5.3.6	ultraviolet radiation, <i>see</i> ultraviolet radiation	
fan not running	4.3.12	with a tool	1.7.16
general	4.7.1	within a battery compartment	2.1.1.2
one at a time	1.4.14	acoustic noise hazard	0.2.6
test under abnormal conditions of		actuators, mechanical, in SAFETY INTERLOCK system	2.8.5, 2.8.8
electrical components	5.3.6		
electromechanical components	5.3.5	adhesive	
motors	5.3.2, annex B	ageing test	4.6.5
thermoplastic parts	4.5.2	application	2.10.7 (note), 4.3.2
thermostats	K.6	foil	5.1.4, 5.2.2, 6.2.2
thermal cut-out operates	1.2.11.3	tape, as insulating material	4.7.3.4
within FIRE ENCLOSURE	4.7.3.2	adjustment	
abnormal operating conditions <i>see</i> abnormal conditions		marking	
abrasion resistance test	2.10.6.6 , 2.10.9, R.1	for rated voltage	1.7.4
AC MAINS SUPPLY	1.2.8.1*, 1.7.1	for thermostats etc.	1.7.11
capacitor	1.5.6, 2.1.1.7	mechanical actuators	2.8.8
connections	3.2.1.1 , 5.1.2	must not create a hazard	4.3.3
equivalent source	1.2.8.1, 1.4.5	worst case conditions for test	1.4.4, 1.4.10, 2.1.1.1, 2.1.1.5, 2.5, 4.3.8, annex H, annex X
for a limited power source	2.5	air gap	
frequency	1.4.7	behind conductive ENCLOSURE	2.10.3.1, 4.2.1, G.6
isolation <i>see</i> disconnection		CLEARANCE applicable	2.10.3.1, G.6
neutral	3.4.6, 3.4.7	CLEARANCE not applicable	2.10.3.1, G.6
terminals	1.7.7.2, 3.3	disconnect device	3.4.2
<i>see also</i> mains, power supply cord, PRIMARY CIRCUIT and wiring terminals		SAFETY INTERLOCK switch	2.8.7.1
a.c. power distribution system		tip of test finger if voltage is over 1 kV	2.1.1.1, annex F (figure F.12 point A)
<i>see</i> power distribution system, a.c.		altitude (elevation) during operation	0.1, 1.1.2, G.6
access, accessibility		ampacity <i>see</i> current-carrying capacity and wiring terminals - current-carrying capacity	
by		antenna	clause 7 (note 1), 7.3.1, 7.3.2, N.2 (figure N.2)
a SERVICE PERSON <i>see</i> SERVICE ACCESS AREA		as a CABLE DISTRIBUTION SYSTEM	1.2.13.14
a USER or OPERATOR <i>see</i> OPERATOR ACCESS AREA		aperture <i>see</i> opening in an ENCLOSURE	
<i>see also</i> RESTRICTED ACCESS LOCATION		appliance coupler	annex P (IEC 60320)
definition	1.2.7*	as disconnect device <i>see</i> disconnection for servicing	
means OPERATOR access (area)	1.2.7.1	as means of connection to earth	2.6.5.4
prevention by a SAFETY INTERLOCK <i>see</i> SAFETY INTERLOCK		as means of connection to power	3.2.1.1, 3.2.1.2
through an opening in an ENCLOSURE		fault testing	5.3.6
2.1.1.1, annex F (figure F.12, point A)		in PLUGGABLE EQUIPMENT	1.2.5.1, 1.2.5.2
to		ON DETACHABLE POWER SUPPLY CORD	1.2.5.4, 3.2.5.1 (note 1)
CABLE DISTRIBUTION NETWORK	7.2 (6.2)	reversible (unpolarized)	3.4.6 (note), 4.3.7
connector shell	2.1.1.1	that fills an aperture in an ENCLOSURE	4.7.3.2
connectors, by a SERVICE PERSON	4.3.5	appliance inlet	3.2.4
control	4.3.3	earthing terminal	2.6.4.2, 2.6.4.3
ELV CIRCUIT <i>see</i> ELV CIRCUIT, accessibility		<i>see also</i> appliance coupler	
energized part	0.1, 2.1.1	applicability	
handles, levers, knobs	2.1.1.6	of requirements	1.3.1
internal wiring	2.1.1.3, 2.1.1.4	of tests	1.4.1, 1.5.2
laser radiation <i>see</i> laser radiation		of this standard	1.1.1
moving part	2.8.2, 4.4		
plugs and sockets, by a SERVICE PERSON	4.3.5		
SAFETY INTERLOCK	2.8.3, 2.8.6		

arcing			
as energy hazard		0.2.2	
causing ignition of air filter		4.7.3.5	
in FIRE ENCLOSURE		4.7.2.1, 4.7.3.2	
in thermostats		K.1	
asbestos, not to be used as insulation		2.9.1	
attitude	see	orientation	
AWG (American Wire Gage)		2.6.3.3 (table 2D), 3.2.5.1 (table 3B)	
B			
backup			
overcurrent protection		2.7.3	
source of power	see	multiple power sources	
baffle in bottom of FIRE ENCLOSURE		4.6.2	
ball pressure test on thermoplastic part		4.5.2	
bandwidth of measuring instrument		1.4.7, S.1	
barrier		0.2.3	
for electrical separation		2.2.3.1	
for power connection		3.1.9	
in bottom of FIRE ENCLOSURE		4.6.2	
in TRANSPORTABLE EQUIPMENT		4.6.4	
no mechanical strength test within MECHANICAL ENCLOSURE		4.2.1	
secured with adhesive		4.6.5	
to prevent ignition		4.6.2, 4.7.3.1, 4.7.3.4, 4.7.3.5	
BASIC INSULATION		0.2.1, 1.2.9.2*, 1.2.9.3, 1.2.9.4, 1.2.9.5 (note)	
application		2.1.1, 2.1.1.1, 2.9.3	
in			
an ELV CIRCUIT		1.2.8.6, 2.1.1.3	
a FUNCTIONAL EARTHING circuit		2.6.2	
an SELV CIRCUIT		2.2.1, 2.2.3.2, 2.2.3.3, 2.2.4	
a TNV CIRCUIT		2.3.2, 2.3.3, 2.3.4	
a wound component		2.10.5.4, annex U	
on coated printed board		2.10.6, annex F (figure F.11)	
bridging	see	bridging of insulation	
consequences of failure		2.2.1, 2.2.3, 2.3.2, 2.4.1, 2.6.1	
dimensions		2.10.3, 2.10.4, 2.10.5 , annex F, G.6 , R.2	
electric strength		5.2	
failure to be simulated		1.4.14	
integrity			
after a test		5.3.4, 5.3.8.2	
in service		3.3.8	
interchanged with SUPPLEMENTARY INSULATION		2.9.3	
one element of DOUBLE INSULATION		2.10.2, 5.2.2, 5.3.8.2	
short-circuited before test		2.3.2	
WORKING VOLTAGE		2.10.2	
battery			
as SECONDARY CIRCUIT		1.2.8.4	
in a limited power source		2.5	
replaceable		1.7.15, 4.3.8	
requirement		4.3.8	
battery backup systems, not in Scope of this standard		1.1.3	
battery compartment, access to a TNV CIRCUIT		2.1.1.2	
bead, ceramic		3.1.5	
OPERATOR access		2.1.1.1 (note 1)	
belt		2.1.1.1, 2.9.1, 4.7.3.3, 4.7.3.4	
Bibliography			annex Q
body (human)			
current through		0.2.1, 5.1.4 (note 1), 5.1.6 (note), annex Q (IEC 60479-1), annex W	
see also		TOUCH CURRENT	
effect of ultraviolet radiation			4.3.13.4
BODY (of equipment)			1.2.7.5*
conductive		1.6.4, 2.9.3 (note to table 2G), 5.1.3, 5.2.2 (table 5B part 1)	
bonding	see	PROTECTIVE BONDING CONDUCTOR and protective earthing and bonding	
BOUNDING SURFACE		1.2.10.1, 1.2.10.2, 1.2.10.3*	
breakdown (of insulation)	see	failure (of insulation)	
bridging of insulation		1.5.7, 2.9.3, 6.1.2.1	
by			
capacitor		1.5.6, 1.5.7.2, 1.5.8, 5.2.2 (note 2)	
conductive object		4.6.4, C.2	
resistor		1.5.7.3, 5.2.2 (note 3)	
surge suppressor		6.1.2.1	
components removed for test			see component - removal during a test
in TRANSPORTABLE EQUIPMENT			4.6.4
permitted with conditions		1.5.7, 2.2.4, 2.3.4, 2.4.3	
under fault conditions		3.1.6, 3.1.9, 3.3.8, C.2	
see also		energy hazard and short-circuit of insulation for test	
building installation (fixed wiring)		1.2.5.1, 1.2.5.2, 1.2.5.3, 1.2.13.10, 2.7.4	
see also		IEC 60364, all parts	
disconnect device in		1.7.2, 3.4.3, 3.4.6, 3.4.7	
not in Scope of this standard		1.1.3	
protective device in		2.7.1, 2.7.3, 2.7.4 (note 2)	
special earthing requirements		annex Q (IEC 364-7-707)	
building wiring	see	building installation	
BUILDING-IN, EQUIPMENT FOR	see	EQUIPMENT FOR BUILDING-IN	
burn hazard		0.2.1, 0.2.2, 0.2.4	
see also		flammability	
busbar			
as internal wiring			3.1.1
as PROTECTIVE EARTHING CONDUCTOR			2.6.4.3
colour			2.6.3.5
bushings			
as cord anchorage			3.2.6
in metal			3.1.2
power cord			3.2.7, 3.2.8
business equipment			1.1.1
normal load conditions			annex L
C			
CABLE DISTRIBUTION SYSTEM		1.2.13.14*, clause 7	
connected to a circuit in equipment		2.2.2 (note), 7.1	
connections to		1.2.11.6, clause 7	
earthing requirements			2.6 (note), 2.6.5.8, 5.1.8.1, 5.1.8.2, 7.1
not a reliable earth			2.6.5.8
not a TELECOMMUNICATION NETWORK			1.2.13.8, clause 7 (note 3)

separation from hazardous voltage	7.1	chemical hazard	0.2.7
parts of equipment	7.2	in battery	4.3.8
TOUCH CURRENT to	2.6.1 g), 2.6.3.1, 5.1.8.1	ozone	1.7.2
		see also corrosion	
CABLE, INTERCONNECTING		CIE (Commission Internationale de l'Eclairage)	
see INTERCONNECTING CABLE		Publication 63	4.3.13.4 (note 3), annex Q
cables		circuit characteristics (definitions)	1.2.8*
earthing conductor, colour of insulation	2.6.2, 2.6.3.5	circuits	
FIRE ENCLOSURE not required	4.7.2.2	interconnection	3.5.1, 3.5.2
power	3.3.4, 3.3.5, annex P (IEC 60227, IEC 60245, IEC 60885-1)	ELV see ELV CIRCUIT	
telecommunication	6.3 (note 2)	LIMITED CURRENT see LIMITED CURRENT CIRCUIT	
television distribution	1.2.13.14	PRIMARY see PRIMARY CIRCUIT	
		SECONDARY see SECONDARY CIRCUIT	
calibre of conductor see current-carrying capacity		SELV see SELV CIRCUIT	
		TNV see TNV CIRCUIT	
capacitors		classification of equipment (protection against electric shock)	1.2.4*
class X (IEC 60384-14)	1.5.6	CLASS I EQUIPMENT	1.2.4.1*, 1.7.2 (note 4), W.1
class Y (IEC 60384-14)	1.5.6, 1.5.7.2, 1.5.8	CLASS II EQUIPMENT	1.2.4.2*, 1.7.1, W.1
connected to IT power distribution system	1.5.8	CLASS III EQUIPMENT	1.2.4.3*
energy hazard	2.1.1.5	CLEARANCE	1.2.10.1*, 2.10.1, 2.10.3.1 , annex F, annex G
failure	1.4.14	as FUNCTIONAL INSULATION	5.3.4
IEC 60065	4.7.3.6	behind conductive ENCLOSURE	2.10.3.1, 4.2.1, G.6
in a circuit	1.5.6, 1.5.8	divided by floating part	2.10.1, annex F (figure F.13)
in filter	1.5.6, 1.5.8, 5.2.2 (notes 2 and 3)	in	
discharging	2.1.1.7	encapsulated part	2.10.8
in FIRE ENCLOSURE	4.7.3.4	enclosed part	2.10.7
motor	B.5, B.8	PRIMARY CIRCUIT	2.10.3.2 , annex G
not protected by fuse	5.3.7	SECONDARY CIRCUIT	2.10.3.3 , annex G
separate testing see separate testing		increased by coating	2.10.9
stored charge	2.1.1.7, 2.4.2 , annex P (IEC 61965)	integrity in service	2.10.1, C.2
cathode ray tube, mechanical strength	0.2.5, 4.2.1, 4.2.8	measured through an opening	2.10.3.1, annex F (figure F.12 point B), G.6
CCITT Recommendations see ITU-T Recommendations		reduced	R.2
note - CCITT Recommendations are now ITU-T Recommendations		varying	2.10.10
ceiling-mounted equipment	4.2.10	WORKING VOLTAGE	2.10.2
cemented joints		see also IEC 60664 (all parts), interpolation, TELECOMMUNICATION NETWORK TRANSIENT VOLTAGE, transients and separation distances	
in insulation	2.10.8, annex F (figures F.5, F.6 and F.7)	cmil see AWG	
in winding wire	2.10.5.4	coated printed board	2.10.6 , annex F (figure F.11), R.1
ceramic and glass insulation		colours	
CREEPAGE DISTANCE	2.10.4	controls and indicators	1.7.8.2, annex P (IEC 60073, ISO 3864)
flammability, no test	4.7	flexible printed wiring	2.6.3.5
on printed board	2.10.5.3 (table 2M)	FUNCTIONAL EARTHING conductor	2.6.2
temperature during a test	4.5.1 (table 4B part 2), 5.3.8.1	PROTECTIVE EARTHING CONDUCTOR	2.6.3.5, 3.2.5.1
see also bead, ceramic		comparative tracking index (CTI) see tracking	
CFR 47, part 68	M.3 (note), annex Q	compliance checked by inspection of relevant data	1.4.15
		see also separate testing	

component	1.2.11*	controls	
bridging insulation	see bridging of insulation	manual	2.1.1.8
electromechanical	see electromechanical component	accessibility	4.3.3
high voltage	4.7.3.6	fixing	4.3.2
material selection	4.7.3	isolation	2.1.1.6
removal during a test	2.10.3.4, 5.1.5, 5.2.2, 6.1.2.1, 6.2.2.2, 6.2.2.3	operated during a test	1.4.4, 5.1.5, 5.3.7, annex H
selection	0.3, 1.5.1 , 1.5.8, 4.7.1	marking	1.7.8
separate testing	see separate testing	supply voltage adjustment	1.7.4, 4.3.3
voltage rating	1.5.8, 1.6.4	temperature	4.5.1 (table 4B part 2)
wound	2.10.5.4, 5.3.5, annex U	see also colours and symbols	
	see also capacitor, resistor, sealed components, semiconductor device and transformer	cord anchorage, power cord	3.2.6
conductive liquid	see liquid - conductive	cord guard (for power cord)	3.2.7, 3.2.8
conductor	see busbar and wire, wiring	integral with cord	1.2.5.5
conductor size	see current-carrying capacity	cord, power supply	see power supply cord
connection terminals		cord, telephone	2.1.1.2 (note)
see wiring terminals		corrosion	
connections		by consumable materials	4.3.10
between circuits	2.2.4, 2.3.4, 2.4.3	by electrochemical action	annex J
FUNCTIONAL EARTHING	2.6.2	by environment	1.1.2
to		in protective earthing connection	2.6.5.6
CABLE DISTRIBUTION SYSTEM	1.1.1, 2.2.2 (note), clause 7	country notes <i>can be found in the following subclauses:</i>	
multiple power sources	see multiple power sources	general	1.1.2, 1.2.13.10, 3.2.5.1 (table 3B), M.1
other equipment	see interconnection of equipment	Australia	1.6.1, 2.1, 3.2.3, 3.2.5.1, 4.3.6, 6.2.2, 6.2.2.1, 6.2.2.2
protective earth	2.6 , 2.9.3	Canada	2.2.3, 2.3.2, 3.2.3, 4.7.2.2, 4.7.3.1
supply source	1.2.5*, 3.1, 3.2, 3.3, 5.1.2	CENELEC countries	2.7.1, annex H
TELECOMMUNICATION NETWORK	1.1.1, 1.4.11, 2.2.2 (note), clause 6 , annex Q (CFR 47, part 68)	Denmark	1.7.2, 2.3.2, 2.3.3
see also disconnection and INTERCONNECTING CABLE		France	annex V (figure V.7)
connectors		Germany	1.7.12 (note 2)
contact by test probe	2.1.1.1, 6.2.1	Finland	1.7.2, 2.3.2, 2.3.3, 2.3.4, 6.1.2.1, 6.1.2.2
FIRE ENCLOSURE not required	4.7.2.2	Japan	G.2.1
flammability	4.7.2.2, 4.7.3.3, 4.7.3.4	Norway	1.5.8, 1.7.2, 2.2.4, 2.3.2, 2.3.3, 2.3.4, 2.10.3.1, 6.1.2.1, 6.1.2.2, G.2.1, annex V (figure V.7)
mismatching, not to create a hazard	4.3.5	Sweden	1.5.1, 1.7.2, 2.3.2, 6.1.2.1, 6.1.2.2
multiway	3.1.9	United Kingdom	3.2.1.1, 4.3.6
power	3.2	United States of America	2.2.3, 2.3.2, 3.2.3, 4.7.2.2, 4.7.3.1
protective earthing contact in	2.6.4.2, 2.6.5.3, 2.6.5.4	covering, protective, in place during a test	5.3.1
see also appliance coupler, appliance inlet, mains plug and socket-outlet		covers	
construction		of supply wiring space	3.2.9
details	4.3	transparent, no mechanical strength test	4.2.1
general requirements	1.3.1, 1.3.2	see also doors and covers	
not covered by this standard	1.3.4	CREEPAGE DISTANCE	1.2.10.2*, 2.10.1, 2.10.4 , annex F
consumable supplies	0.2.3, 0.2.7, 1.4.14, 4.7.3.2, 4.7.3.3, 4.7.3.4	as FUNCTIONAL INSULATION	5.3.4
contact		divided by floating part	2.10.1, annex F (figure F.13)
gap see air gap		in encapsulated part	2.10.8
pressure	3.1.6, 3.1.7, 3.3.6, 3.3.8	in enclosed part	2.10.7
see also access		increased by coating	2.10.9
CONTINUOUS OPERATION	1.2.2.3*, 4.5.1	integrity in service	C.2
control, quality	see quality control	measured through an opening	2.10.4, annex F (figure F.12 point B)
		not less than CLEARANCE	2.10.4
		varying	2.10.10
		WORKING VOLTAGE	2.10.2, 2.10.4
		see also IEC 60664, interpolation, and separation distances	
		CTI (comparative tracking index) see tracking	
		current	
		in human body	0.2.1
		input, determination	1.4.10
		input, maximum	1.6.2

limiter	2.5	disconnect device	3.4.2, 3.4.6, 3.4.7
locked rotor	B.1, B.5	appliance coupler	2.6.5.4, 3.4.2
maximum ringing signal	M.2, M.3	in building installation	1.7.2, 3.4.3, 3.4.6, 3.4.7
r.m.s. value implied unless otherwise specified	1.2	single phase	3.4.6
to telecommunication wiring	6.3	switch	3.4.5, 3.4.8
<i>see also</i> PROTECTIVE CONDUCTOR CURRENT, TOUCH CURRENT <i>and</i> RATED CURRENT		three-phase	3.4.7
current-carrying capacity		from CABLE DISTRIBUTION SYSTEM	2.3.2
INTERCONNECTING CABLE	3.1.1	from multiple sources, marking	1.7.9
internal wiring	3.1.1	from protective earth	2.6.5.3, 2.6.5.5
power supply cord	3.2.5.1, 3.2.5.2	from TELECOMMUNICATION NETWORK	2.1.1.2, 2.3.2
PROTECTIVE BONDING CONDUCTOR	2.6.3.3	of components, during a test	<i>see</i> component - removal during a test
for an SELV CIRCUIT	2.2.3.3	of heating element	4.3.7
PROTECTIVE EARTHING CONDUCTOR	2.6.3.2	distance through insulation	2.10.5.1 , 2.10.8
telecommunication wiring	6.3	printed board	2.10.5.3
wiring terminals		varying	2.10.10, 5.2.2
<i>see</i> wiring terminals - current-carrying capacity		wiring in an ELV CIRCUIT	2.1.1.3
CUT-OUT, THERMAL <i>see</i> THERMAL CUT-OUT		doors and covers	4.2.3, 4.6.1, 4.6.3
D		access through <i>see</i> opening in an ENCLOSURE - access	
d.c. component of waveform	1.4.7, 2.3.1	marking on or near	1.7.1, 4.3.13.4
<i>see also</i> ripple		position during a test	2.1.1.1, 4.1, 4.3.13.4, 4.4.2, 4.6.4
d.c. current for test	2.6.3.4	<i>see also</i> SAFETY INTERLOCK	
DC MAINS SUPPLY	1.2.8.2*, 1.7.1	DOUBLE INSULATION	0.2.1, 1.2.9.4*, 1.2.9.5
capacitor	2.1.1.7	application	2.9.3
circuitry considered to be a SECONDARY CIRCUIT	1.2.8.2	in	
connections	3.2.1.2	a FUNCTIONAL EARTHING circuit	2.6.2
isolation <i>see</i> disconnection		a HAZARDOUS VOLTAGE circuit	2.1.1.4
polarity	1.4.5, 1.7.7.3	manual control	2.1.1.6
power cord	3.2.5.2	printed board	2.10.6
symbol for supply	1.7.1	an SELV CIRCUIT	2.2.3.1, 2.2.4
terminals	1.7.7.3	a TNV CIRCUIT	2.3.3, 2.3.4
TOUCH CURRENT requirements not applicable	5.1	a wound component	2.10.5.4, annex U
<i>see also</i> mains <i>and</i> PRIMARY CIRCUIT		BASIC and SUPPLEMENTARY can be interchanged	2.9.3
transients	2.10.3.3, G.2.2	bridging <i>see</i> bridging of insulation	
d.c. motor, testing	B.1, B.6, B.7, B.10	care during electric strength tests	5.2.2
d.c. power source	1.4.5, 1.7.1, 2.6.3.4, 5.2.2 (table 5B, items 2 to 5)	dimensions <i>see</i> BASIC INSULATION <i>and</i> SUPPLEMENTARY INSULATION	
d.c. power supply distribution system	<i>see</i> power distribution system, d.c.	integrity	
DC VOLTAGE	0.2.1, 1.2.13.4*	after a test	5.3.8.2
for test, instead of a.c.	5.2.2, 6.2.2.3, annex R	in service	3.3.8
for testing a capacitor	5.2.2 (note 2)	protective device not needed	2.7.4
<i>see also</i> ripple		unearthed parts within	2.9.3
DECORATIVE PART	1.2.6.5*, 4.7.3.1 (note 2), 4.7.3.3	WORKING VOLTAGE	2.10.2
<i>see also</i> ENCLOSURE		meaning, for DOUBLE INSULATION	2.10.2
definitions	1.2*	drop test	4.2.6
miscellaneous	1.2.13	dust	
design, general requirements	1.3, 4.3, 5.3.1	additional requirements if present	1.1.2, 4.3.10
DETACHABLE POWER SUPPLY CORD <i>see</i> power supply cord		explosion limit	1.2.12.15
different criteria and tests in this standard, manufacturer's choice	1.3.7, 2.3.2	excluded in pollution degree 1	2.10.1
DIRECT PLUG-IN EQUIPMENT	1.2.3.6*, 3.2.1.1, 3.4.2, 4.2.6, 4.3.6	duty cycle, marking SHORT-TIME and INTERMITTENT	1.7.3
disconnection		E	
automatic	2.7 , 4.3.7, 5.3.2 (note)	earth, earthing	0.2.1, 2.6
by a SAFETY INTERLOCK	2.8	a.c. power distribution system	annex V
for servicing (isolation)	3.4	functional earthing	1.2.13.9*, 2.6.2
		permanent connection	6.1.2.2
		protective <i>see</i> PROTECTIVE BONDING CONDUCTOR, protective earthing and bonding, PROTECTIVE EARTHING CONDUCTOR <i>and</i> screen, conductive, earthed	
		rise of potential, not covered by this standard	1.4.8 (note)
		voltage measurement to	1.4.9

earth fault protection	2.7	endurance testing	
<i>see also</i> overcurrent protection device		capacitors	1.5.8 (note)
earth leakage current	<i>see</i> TOUCH CURRENT	SAFETY INTERLOCK switch	2.8.5, 2.8.7.3
electric shock	0.2.1 , 1.3.2	thermal control	annex K
caused by		energy hazard	0.2.2, 5.3.8.1
heat damage	5.3.4	disconnection	3.4.10
overload, abnormal operation etc.	5.3.1	in	
stored charge	2.1.1.7	ENCLOSURE	4.2.1, 4.6.1 (note 1)
touching bare conductive part	2.1.1, 5.1	FIRE ENCLOSURE	4.7.2.1
protection	2.1	OPERATOR ACCESS AREA	2.1.1, 2.1.1.5
by insulation	1.2.9	RESTRICTED ACCESS LOCATION	2.1.3
by a SAFETY INTERLOCK	2.8.2	SERVICE ACCESS AREA	2.1.2
by an SELV CIRCUIT	2.2	multiple sources	1.7.9
by a TNV CIRCUIT	2.3	reduced by a SAFETY INTERLOCK	2.8.2
two levels	0.2.1	ENERGY LEVEL, HAZARDOUS	1.2.6.4, 1.2.8.9*
warning symbol	1.7.16, 2.7.6	determination of accessibility	2.1.1.5 a)
electric strength test	5.2	determination of existence	2.1.1.5 c)
not for verifying CLEARANCE	2.10.3.1, annex G	<i>see also</i> energy hazard	
used for verifying solid insulation	2.10.5	environment of equipment	
with or without pre-heating	5.2 (note), 5.2.1	manufacturing	R.1, R.2
WORKING VOLTAGE	2.10.2	special	1.1.2
<i>note - electric strength tests are required in numerous places in this standard</i>		to be taken into account in design	2.6.5.6, 2.9.1
ELECTRICAL ENCLOSURE	1.2.6.4*, 2.1.1.1, 4.7.3.3, 4.7.3.4	<i>see also</i> humidity, pollution degree, temperature	
<i>see also</i> ENCLOSURE <i>and</i>		equipment	
opening in an ENCLOSURE		electrical ratings (definitions)	1.2.1*
electrical filter		not operational after a test	1.4.1, 5.3.1
effect of	2.10.3.2, 2.10.3.4, G.4 a), G.5	EQUIPMENT FOR BUILDING-IN	1.2.3.5*, 2.1.1.1, 4.5.1
electric strength test	5.2.2 (notes 2 <i>and</i> 3)	equivalent level of safety	1.3.4
fault testing	5.3.6	equivalent materials permitted	1.3.5
three-phase, during a TOUCH CURRENT test	5.1.5 (note)	equivalent sources of power	1.2.8.1, 1.4.5
electrochemical potential	2.6.5.6, annex J	EUT equipment under test	
electromechanical component	2.8.4, 2.8.8, 4.7.2.2, 5.3.5	examples given in this standard, others not excluded	1.3.8
elevation	<i>see</i> altitude	explosion	
ELV CIRCUIT	1.2.8.6*	EXPLOSION LIMIT	1.2.12.15, 4.3.12
accessibility	2.1.1.1, 2.1.1.6, 3.2.2	(implosion) of cathode ray tube	0.2.5, 4.2.8
in a SERVICE ACCESS AREA	2.1.2	of battery	1.7.15, 4.3.8
of insulation	2.1.1.3	of high pressure lamp	0.2.5, 4.2.9
as an interconnection circuit	3.5.2, 3.5.3	F	
insulation	2.9.3	failure	5.3.1
operating voltage	1.4.8	consequences	1.3.1
reed switch in	2.8.7.3	(failure, <i>continued</i>)	
similar to an SELV CIRCUIT	2.2.3.3 (note 2)	of	
e.m.c.	<i>see</i> electrical filter	component	0.1, 0.2.1, 0.2.3, 1.4.14, 2.2.3, 2.3.1, 4.3.8, 5.3.6
enamel, solvent-based, not suitable as safety insulation	2.1.1.1 (note 1), 2.10.5.2, 2.10.5.4, 2.10.8	in a battery circuit	4.3.8
encapsulated part	2.10.8, 5.1.5 (note)	in a heating element	4.3.7
enclosed part	2.10.7, B.2, B.5, C.2	in a LIMITED CURRENT CIRCUIT	2.4.1, 2.4.3
ENCLOSURE	1.2.6.1*, 5.3.8.1	in an SELV CIRCUIT	2.2.1, 2.2.4
bottom	4.2.4, 4.2.5, 4.6.1, 4.6.2	in a TNV CIRCUIT	2.3.1, 2.3.2, 2.3.4
definition	1.2.6*	ENCLOSURE	4.2.5, 4.7
flammability	4.7.3.2, A.1, A.2	equipment to operate, evident to an OPERATOR	5.3.5
mechanical strength	4.2	insulation	0.1, 0.2.3, 1.4.14, 2.2.3, 2.3.1, 2.4.3
metallized plastic, in TRANSPORTABLE EQUIPMENT	4.6.4	motor capacitor	B.8
<i>see also</i> air gap behind conductive ENCLOSURE,		SAFETY INTERLOCK system	2.8.4
DECORATIVE PART, ELECTRICAL ENCLOSURE, FIRE		screwed connection	4.3.4
ENCLOSURE, water ingress, MECHANICAL ENCLOSURE		mechanical	5.3.5
<i>and</i> opening in an ENCLOSURE		<i>see also</i> fault	

fault		1.3.2	fire hazard	0.2.3, 0.3, 1.1.1, 1.2.9.1 (note), 1.3.2, 4.7 , annex P (IEC 60695)
consequential	0.1, 0.2.1, 1.4.14, 5.3.5		caused by	
earth	2.7.1, 2.7.4, 4.3.7		battery	4.3.8
in			breakdown of FUNCTIONAL INSULATION	1.2.9.1 (note), 5.3.4, 5.3.8
equipment earthed for safety purpose	2.6.1		flammable liquid	4.3.10, 4.3.12
LIMITED CURRENT CIRCUIT	1.2.8.8, 2.4.1		heating element	4.3.7
limited power source	2.5		overload	5.3.1
metallized enclosure	4.6.4		water ingress	annex T
power distribution system	1.2.13.8 (note 2)		see also flammability	
protective earthing connection	5.1.1, 5.1.5		fire protection equipment, not in Scope of this standard	1.1.3
ringing signal circuit	M.2, M.3		fixed wiring	see building installation
SELV CIRCUIT	1.2.8.7, 2.2		fixing (securing) of	
TNV CIRCUIT	1.2.8.10, 2.3.1, 2.3.2		equipment	1.2.3.4, 1.2.3.5
not covered in 5.3	2.7.2		units, fixed together	4.1
simulated	1.4.14, 2.3.4, 2.7.4, 5.3.5, 5.3.6		parts	
single	0.2.1, 1.4.14, 2.9.3		adhesive	4.6.5
see also abnormal conditions and failure			conductors	see wiring terminals
fault condition		1.3.2	control	4.3.2
difference between an ELV CIRCUIT and an SELV CIRCUIT			cord guard	3.2.8
	2.2.3.3 (note 2)		inlet bushing	3.2.7
protection required	2.7.1, 2.7.3, 2.7.4, 4.7.3.3, 4.7.3.4		insulation	3.1.5
fault current		2.2.3.3, 2.7.3, 2.7.4	minor part	4.3.4
in PROTECTIVE EARTHING CONDUCTOR		2.6.1, 2.6.3	two fixings not loose at the same time	3.1.9, 4.3.4, C.2
FCC Rule, Part 68		M.3 (note), annex Q	wiring	2.1.1.3, 2.1.1.4, 2.2.3.1, 3.1.3
FEP (fluoro ethylene propylene)		4.7.2.2, 4.7.3.3, 4.7.3.4	flammability	0.2.3, 0.2.4, 1.2.12*, 4.7
filter, air, flammability		4.7.3.5	better class permitted	1.3.5
filter, electrical	see electrical filter and capacitors in filter		exemption from flammability requirement	4.7.3.3, 4.7.3.4
FIRE ENCLOSURE		1.2.6.2*	of fluids	4.3.12
air filter in		4.7.3.5	ranking (one class better than another)	1.2.12.1 (notes), 1.3.5
components in		4.7.2.1, 4.7.2.2	summary of requirements	table 4D
construction		4.6.2, 4.6.3, 4.7.1	tests	Annex A, Annex P (IEC 60695-x, ISO 9772, ISO 9773)
material		4.7.3.2	FLAMMABILITY CLASSES	1.2.12.1*, 1.3.5, table 4D
not required		1.4.11, 4.7.2.2	equivalence of V-series and VTM-series	4.7.3.1
required		4.7.2 , 4.7.2.1	5VA	1.2.12.1 (notes 2 and 5), 1.2.12.5*
see also ENCLOSURE and opening in an ENCLOSURE			note - 5VA CLASS is not required in this standard	
			5VB	1.2.12.1 (notes 2 and 5), 1.2.12.6*
			application	4.7.3.2
			HB40	1.2.12.1 (notes 2 and 5), 1.2.12.10*
			application	4.7.2.2, 4.7.3.3, 4.7.3.4, 4.7.3.5
			glow-wire test acceptable	4.7.3.1
			HB75	1.2.12.1 (notes 2 and 5), 1.2.12.11*
			application	4.7.2.2, 4.7.3.3, 4.7.3.4, 4.7.3.5
			glow-wire test acceptable	4.7.3.1
			HBF (foamed material)	2.12.1 (note 1), 1.2.12.9*
			application	4.7.2.2, 4.7.3.3, 4.7.3.4, 4.7.3.5
			glow-wire test acceptable	4.7.3.1
			HF-1 (foamed material)	1.2.12.1 (note 1), 1.2.12.7*
			application	4.6.2
			HF-2 (foamed material)	1.2.12.1 (note 1), 1.2.12.8*
			application	4.7.3.4, 4.7.3.5, 4.7.3.6
			V-0	1.2.12.1 (notes 2 and 4), 1.2.12.2*
			note - V-0 CLASS is not required in this standard	
			V-1	1.2.12.1 (notes 2 and 4), 1.2.12.3*
			application	4.6.2, 4.7.2.1, 4.7.2.2,
				4.7.3.1, 4.7.3.2, 4.7.3.3, 4.7.3.4, 4.7.3.5, 5.3.4
			V-2	1.2.12.1 (notes 2 and 4), 1.2.12.4*
			application	4.7.3.3, 4.7.3.4, 4.7.3.5, 4.7.3.6
			(flammability classes, continued)	

VTM-0	1.2.12.1 (note 3), 1.2.12.12*	gas flame for flammability testing	A.1.4, A.2.4
equivalent to V-0	1.2.12.1 (note 4), 4.7.3.1	gases	
<i>note - VTM-0 and V-0 CLASSES are not required in this standard</i>		flammable	1.1.2, 1.2.12.15, 4.3.10
VTM-1	1.2.12.1 (note 3), 1.2.12.13*	inert, in a sealed unit	4.7.3.3, 4.7.3.4
equivalent to V-1	1.2.12.1 (note 4), 4.7.3.1	produced by equipment	4.3.10
VTM-2	1.2.12.1 (note 3), 1.2.12.14*	under pressure	4.3.11
equivalent to V-2	1.2.12.1 (note 4), 4.7.3.1	gel dielectric	2.10.5.1
floating parts and windings		glass	
see unearthed parts and windings		cloth, prepreg	2.10.5.3 (table 2M)
foil (conductive)		flammability, no test	4.7
in definition	1.2.7.5, 1.2.10.3	platen, no impact test	4.2.5
in test		see also ceramic and glass insulation	
on a non-conductive surface		glow-wire test	annex P (IEC 60695-2-1/1)
2.10.3.1, 2.10.4, 2.10.8, 5.1.4, 5.2.2, 6.2.2, G.6		acceptable for HB40, HB75 and HBF	4.7.3.1
on wire	3.1.4	grease	see oil and grease
metallized plastic	4.6.4 (note)	green-and-yellow	see colours
frequency		grips	see handles and levers
higher than 50/60 Hz	0.2.6, 1.4.7, 5.1.6, 5.2.2 (note 4)	ground, grounding,	see earth, earthing
in a LIMITED CURRENT CIRCUIT	2.4.2	guard, guarding, against hazards	0.1, 2.1.1.1, 2.1.2, 2.1.3, 2.8.3, 3.3.8, 3.4.4, 3.4.10, 4.4.1
in a TNV CIRCUIT	2.3.1 b), 6.2.2.1	see also cord guard	
of electric strength test voltage	5.2.2, R.1, R.2		
of ringing signal	M.2 (note), M.3.1.1		
see also RATED FREQUENCY and RATED FREQUENCY RANGE			
of supply	1.7.1, 1.7.4, 3.4.11, 3.2.2		
during a test	1.4.4, 1.4.6		
of WORKING VOLTAGE	2.9.1, 2.10.1		
FUNCTIONAL EARTHING	1.2.13.9*, 2.6.2, 2.6.3, 5.1.5, 5.1.8.1		
FUNCTIONAL INSULATION	1.2.9.1*, 5.3.4		
application	2.1.1.1, 2.9.3		
bridging	see bridging of insulation		
dimensions	2.10.3, 2.10.4, annex F		
coated printed board	2.10.6, annex F (figure F.11)		
distance through insulation, no requirement	2.10.5.1		
electric strength	5.2, 5.3.4 b)		
no test	5.2.2		
failure to be simulated	5.3.4 c)		
no protection against electric shock	1.2.9.1 (note)		
smaller spacing permitted	2.10.1, 5.3.4		
WORKING VOLTAGE	2.10.2		
<i>note - the term FUNCTIONAL INSULATION has replaced the term OPERATIONAL INSULATION</i>			
fuse	annex Q (IEC 60127, IEC 60269-2-1)		
breaking capacity	2.7.3 (note)		
in neutral conductor	2.7.6		
location	2.7.1, 2.7.4		
marking	1.7.6		
minimum number	2.7.4		
not allowed in protective conductor	2.6.5.2		
operating during motor test	B.2		
performance	2.5 (table 2C item 4)		
protecting a capacitor	5.3.7		
protecting telecommunication wiring	6.3 (notes 1 and 4)		
warning to SERVICE PERSON	2.7.6		
fuseholder	2.1.1.1 b), 2.1.1.1 c), 4.7.3.2 (note)		
G			
gap	see air gap		
gas discharge tube	see surge arrester		
		hand, human	see body - human
		HAND-HELD EQUIPMENT	0.1, 1.2.3.2*, 3.2.8, 3.2.9
		maximum RATED VOLTAGE 250 V	1.6.3
		mechanical strength	4.2.6
		power supply cord	3.2.5.1
		TOUCH CURRENT	5.1.6 (table 5A)
		handles and levers	
		conductive	2.1.1.6
		must be reliably fixed	4.3.2
		no mechanical strength test	4.2.1
		part of BODY	1.2.7.5
		shaft of	2.1.1.6
		temperature	4.5.1 (table 4B part 2)
		hazard	clause 0
		access using a TOOL	1.7.16
		acoustic	0.2.6
		basis of design	0.1, 1.3.2
		energy	see energy hazard
		fire	see fire hazard
		information to the USER	1.7.2
		mechanical	see mechanical hazard
		none after mechanical strength test	4.2.1, 5.3.8.2
		SERVICE PERSON aware of	0.1, 1.2.13.5
		HAZARDOUS ENERGY LEVEL	1.2.6.4, 1.2.8.9*
		see also energy hazard	
		HAZARDOUS VOLTAGE	0.2.1, 1.2.8.5*
		multiple sources	see multiple power sources
		not to be accessible	2.1.1.1
		after mechanical strength test	4.2.1, 5.3.8.2
		at an appliance inlet	3.2.4
		at a connector	3.1.9, 3.2.2
		in an OPERATOR ACCESS AREA	2.1
		in a RESTRICTED ACCESS LOCATION	2.1.3
		in a SERVICE ACCESS AREA	2.1.2
		on a thermoplastic part	4.5.2

protection by earthing	2.2.3.3, 2.6.1, 6.1.1, 7.1.1	IEC 60529	annex T, annex Q
separation from		IEC 60664-1	2.10.1 (note), 2.10.3.1 (notes 1 <i>and</i> 2), 2.10.3.2, clause 6 (note 4), clause 7 (note 3), G.2.1, G.6, annex P
ELV CIRCUIT	1.2.8.6		
FUNCTIONAL EARTHING circuit	2.6.2		
SELV CIRCUIT	2.1.2, 2.2.3, 2.2.4	IEC 60664-4	2.10.1 (note), annex Q
TNV CIRCUIT	2.1.2, 2.3.3, 2.3.4		
warning notice	1.7.9, 2.7.6	IEC 60695-2-1/1	4.7.3.1, annex P
heat		IEC 60695-2-2	4.6.2, 4.7.3.6, A.2.7, annex P
ceramic printed board curing temperature	2.10.5.3 (table 2M)	IEC 60695-2-20	4.7.3.2, annex P
hazard	0.2.4	IEC 60695-10-2	4.5.2, annex P
shock test on winding wire	U.2.3	IEC 60695-11-3	A.1.4, annex P
sink	4.5.1, B.2	IEC 60695-11-4	A.2.4, annex P
<i>see also</i> fire hazard		IEC 60695-11-10	1.2.12.1, 1.2.12.2, 1.2.12.3, 1.2.12.4, 1.2.12.10, 1.2.12.11, annex P
heating	4.5	IEC 60695-11-20	1.2.12.1, 1.2.12.5, 1.2.12.6, annex P
maximum, during a transformer test	annex X	IEC 60730-1	2.5, annex P
heating element	4.3.7	IEC 60825-1	4.3.13.5, annex P
high voltage component	4.7.3.6	IEC 60825-2	4.3.13.5, annex P
hot flaming oil test	4.6.2, A.3	IEC 60825-9	4.3.13.4, annex P
hot part symbol	4.5.1 (table 4B, item 6)	IEC 60851-3	annex P, U.2.2
hot wire ignitability test (IEC 60695-2-20)	4.7.3.2	IEC 60851-5	annex P, U.2.1, U.2.4 (note), U.3.2
human body <i>see</i> body - human		IEC 60851-6	annex P, U.2.3
humidity	2.9.1	IEC 60885-1	3.1.4, annex P
additional requirements if high	1.1.2	IEC 60950, part 21	Foreword
conditioning (treatment)	2.9.2 , 2.10.6.5, 2.10.7, 2.10.8	IEC 60990	5.1.2 (note), 5.1.3, 5.1.4 (note 2), D.1, annex P
relative (r.h.) during a test	4.2.7 (note), 4.6.5, U.2, Y.1	IEC 61032	2.1.1.1 (figure 2A, note 3 <i>and</i> figure 2B, note), annex Q
hygroscopic material, not to be used as insulation	2.9.1	IEC 61058-1	2.8.7, annex P
I		IEC 61140	1.2.8.7 (note 2), annex Q
ICRP 15	annex H (note 1), annex Q	IEC 61965	4.2.8, annex P
IEC 60065	1.1.1 (note), 4.2.8, 4.7.3.6, N.2, annex P	IEC Guide 112	1.1.1 (note), annex Q
IEC 60073	1.7.8.2, annex P	IEV (International Electrotechnical Vocabulary)	1.2.13.2, 1.2.13.3, 1.2.13.9, 1.2.13.12
IEC 60083	1.7.5, 2.1.1.1, 4.3.5, annex P	ignition	0.2.3, 0.2.4, 4.3.12, 4.6.4, 4.7 <i>see also</i> FIRE ENCLOSURE
IEC 60085	4.5.1 (table 4B, item 2), annex P	impact test	4.2.1, 4.2.5
IEC 60112	2.10.4, annex P	implosion of cathode ray tube	0.2.5, 4.2.8
IEC 60127	2.7.3 (note), annex Q	impulse test	2.10.3.4, 6.2.2.1 , 6.2.2.3, 7.3.3 , G.5, R.2 (table R.2, item 2), annex S test generators annex N
IEC 60216-4-1	4.2.7, annex P	indicator, indicating devices	
IEC 60227	3.2.5.1, annex P	colour	1.7.8.2, , annex P (IEC 60073, ISO 3864)
IEC 60245	3.2.5.1, annex P	exempt from mechanical strength requirement	4.2.1
IEC 60269-2-1	6.3 (note 4), annex Q	lamp exempt from flammability requirements	4.7.3.3, 4.7.3.4
IEC 60309	1.2.5.2, 3.2.4, annex P	marking	1.7.8
IEC 60317-43	U.2.2 (table U.1), annex P	information technology equipment	
IEC 60320	3.2.4, 3.2.5.1 (table 3B), 4.3.5, annex P		
IEC 60364-3	annex P, V.1		
IEC 60364-4-41	annex P, V.1		
IEC 60364-7-707	5.1.7 (note), annex Q		
IEC 60384-14	1.5.6, 1.5.7.2, 1.5.8, annex P		
IEC 60410	annex Q, R.1, R.2		
IEC 60417-1	1.7.1, 1.7.7.1, 1.7.8.3, 2.6.2, 2.6.5.1, 2.7.6, 4.3.13.4, 4.5.1 (table 4B item 6), annex P		

connection to			
a CABLE DISTRIBUTION SYSTEM		clause 7	
a TELECOMMUNICATION NETWORK		clause 6, W.2	2.10.5.4, annex U
examples in Scope of this standard		1.1.1	
informative reference		annex Q	
ingress of water	see	water ingress	
ink		4.3.12	
ink tube		4.7.3.3, 4.7.3.4	
inlet bushing, power cord		3.2.7	
installation, building	see	building installation	
installation category	see	overvoltage category	
<i>note - the term overvoltage category has replaced the term installation category</i>			
installation instructions		1.7.1, 1.7.2, 1.7.4, 2.1.1.1	
disconnect device		3.4.3, 3.4.6, 3.4.7, 3.4.9	
orientation		1.3.6	
physical		4.1, 4.2.10, annex T	
removal of all power		3.4.10, 3.4.11	
RESTRICTED ACCESS LOCATION		1.7.17	
wiring			
earth		2.3.2, 3.2.1.2, 3.3.7, 5.1.8.2, 6.1.1, 6.1.2.2, 7.1, 7.3.1	
power		1.7.7.2, 1.7.10, 2.7.1, G.2.1	
telecommunication		6.3	
instructions		0.1, 1.7.2 , 2.6.5.6	
language		1.7.12	
see also		installation instructions, operating instructions and servicing instructions	
insulation (electrical)		0.2.1, 1.2.9*, 2.9	
application		2.9.1, 2.9.3	
BASIC	see	BASIC INSULATION	
better grade necessary		2.9.3	
better grade permitted		1.3.5	
bridging	see	bridging of insulation	
classification		4.5.1 (table 4B)	
colour	see	colours	
compliance checked by inspection of relevant data		1.4.15	
dimensions		2.10	
DOUBLE	see	DOUBLE INSULATION	
fault, simulated		1.4.14	
for more than one requirement		clause 6 (note 3)	
FUNCTIONAL	see	FUNCTIONAL INSULATION	
operational	see	FUNCTIONAL INSULATION	
printed board	see	printed board	
REINFORCED	see	REINFORCED INSULATION	
separate testing	see	separate testing	
solid		2.10.1, 2.10.3.1 (note 3), 2.10.8, 5.2.1	
meaning		2.10.5 (note 1)	
see also		distance through insulation	
SUPPLEMENTARY	see	SUPPLEMENTARY INSULATION	
test		5.2, 5.3.8, 6.1.2, 6.2.2, 7.3, annex S, annex U	
with varying dimensions		2.10.10, 5.2.2	
integrity of protective earthing and bonding		2.6.5	
INTERCONNECTING CABLE		1.2.11.6*, 1.5.5 , 3.1.1, 3.5.1 (note 2)	
part of a PRIMARY CIRCUIT		1.2.8.3 (note)	
part of a SECONDARY CIRCUIT		1.2.8.4 (note)	
part of a TNV CIRCUIT		1.2.8.10 (note 2)	
interconnection of equipment			
1.7.2 (note 1), 2.6.5.1, 3.4.10 , 3.5 , 5.1.2, W.2			
see also		connections	
interleaved insulation in wound components			
interlock	see	SAFETY INTERLOCK	
INTERMITTENT OPERATION		1.2.2.5*, 1.7.3, 4.5.1, 5.3.5, 5.3.7	
internal wiring		2.1.1.3, 2.1.1.4, 3.1.1, 3.1.3, 3.1.4, 3.1.10, 4.7.3.3, 4.7.3.4, C.2	
INTERCONNECTING CABLE, treated as			1.5.5
interpolation, permitted in			
electric strength test voltages		5.2.2 (table 5B, part 2)	
insulation spacings		2.10.3.1 (note 1), tables 2H, 2K, 2L, 2N and G2	
temperature for thermal ageing		2.10.6.4 (figure 2G)	
ionizing radiation		0.2.6, 4.3.13.2 , annex H	
ISDN (Integrated Services Digital Network)		1.2.13.8 (note 3)	
ISO 178		4.3.13.3 (table 4A), annex P	
ISO 179		4.3.13.3 (table 4A), annex P	
ISO 180		4.3.13.3 (table 4A), annex P	
ISO 261		3.3.3, annex P	
ISO 262		3.3.3, annex P	
ISO 527		4.3.13.3, annex P	
ISO 2859-1		annex Q, R.1, R.2	
ISO 3864		1.7.16, 2.7.6, annex P	
ISO 4046		B.7.2 (note), annex Q	
ISO 4892		Y.3, Y.4, annex P	
ISO 7000		1.7.1, annex P	
ISO 8256		4.3.13.3 (table 4A), annex P	
ISO 9772		1.2.12.1, 1.2.12.7, 1.2.12.8, 1.2.12.9, annex P	
ISO 9773		1.2.12.1, 1.2.12.12, 1.2.12.13, 1.2.12.14, annex P	
isolation (from the supply)	see	disconnection for servicing	

IT power distribution system	1.6.1, V.4	liquid	
heating element	4.3.7	conductive	1.3.9 , 4.3.10
marking of equipment	1.7.10	container	4.7.3.4
primary power isolation		under pressure	4.3.11
single phase	3.4.6 (note)	flammable	0.2.3, 0.2.4, 4.3.10, 4.3.12 , 4.5.1 (table 4B part 1)
three phase	3.4.7	parts in contact	4.5.1 (table 4B part 1)
protective device	2.7.4 (tables)	loosening	see fixing
TOUCH CURRENT	5.1.3	louvre	4.6.1
voltage rating of component	1.5.8		see also opening in an ENCLOSURE
ITU-T Recommendation K.11	clause 6 (note 1), annex Q	M	
ITU-T Recommendation K.17	clause 7 (note 1), annex N, annex P	mains	
ITU-T Recommendation K.21	clause 7 (note 1), annex N, annex P	as communication transmission medium	
ITU-T Recommendation K.27	1.2.8.2 (note 1), 2.10.3.3 (note 1), G.2.2 (note), annex Q	1.1.1, clause 6 (note 4), clause 7 (note 3)	
ITU-T Recommendation K.31	clause 7 (note 4), annex Q	not a CABLE DISTRIBUTION SYSTEM	1.2.13.14
		not a TELECOMMUNICATION NETWORK	1.2.13.8
		capacitor	1.5.6, 1.5.8, 2.1.1.7
		frequency	1.4.6, 1.4.7, 1.7.1
		isolation from	see disconnection
		see also	AC MAINS SUPPLY, DC MAINS SUPPLY, DIRECT PLUG-IN EQUIPMENT, PRIMARY CIRCUIT and wiring
		terminals	
		means a.c. or d.c.	1.2.8.2 (note 2)
		plug	1.2.3.6, 3.2.1.1, 3.2.1.2
		design and selection	2.6.5.4, 3.2.2, 4.3.5, 4.3.6
		disconnect device	1.7.2, 3.4.2, 3.4.9
		voltage	1.4.5, 1.7.1, 2.10.3.1, G.2.1
		adjustment	1.7.4, 4.3.3
		d.c.	1.4.5, 1.7.1, 5.2.2 (table 5B, items 2-5)
		line to neutral, used for determining clearance	2.10.3.1, G.2.1 (table G.1)
		mains supply	means AC MAINS SUPPLY and DC MAINS SUPPLY
			1.2.8.1 (note 2), 1.2.8.2 (note 2)
		MAINS TRANSIENT VOLTAGE	1.2.9.9*, 1.4.8, 2.10.3.2, G.2.1 , G.2.2 , G.4
		reduced level in SECONDARY CIRCUIT	2.10.3.3
		measurement	2.10.3.4, G.5
		see also	transients
		markings	0.1, 1.7 , 2.1.1.2
		additional marking requirements	see 1.7 (note)
		durability	1.7.13
		t-marking	4.5.1 (table 4B part 1)
		see also	warning notices
		mass	
		cord anchorage test	3.2.6
		cord guard test	3.2.8
		marking not on bottom of equipment over 18 kg	1.7.1
		of equipment, parameter for requirements and test	1.2.3.1, 2.1.1.1, 3.2.5.1, 4.1, 4.2.4, 4.2.6, 4.7.3.2, A.1, A.2
		steel ball impact test	4.2.5
		material group	see tracking
		materials	
		must be reliable	0.3
		not covered in this standard	1.3.4
		use of better materials permitted	1.3.5
		see also	insulation and separate testing
IT power distribution system	1.6.1, V.4		
heating element	4.3.7		
marking of equipment	1.7.10		
primary power isolation			
single phase	3.4.6 (note)		
three phase	3.4.7		
protective device	2.7.4 (tables)		
TOUCH CURRENT	5.1.3		
voltage rating of component	1.5.8		
ITU-T Recommendation K.11	clause 6 (note 1), annex Q		
ITU-T Recommendation K.17	clause 7 (note 1), annex N, annex P		
ITU-T Recommendation K.21	clause 7 (note 1), annex N, annex P		
ITU-T Recommendation K.27	1.2.8.2 (note 1), 2.10.3.3 (note 1), G.2.2 (note), annex Q		
ITU-T Recommendation K.31	clause 7 (note 4), annex Q		
K			
knobs	see handles and levers		
L			
label	see warning notice		
lamps			
high pressure	0.2.5, 4.2.9		
left in place during a test	2.1.1.1		
no flammability requirement	4.7.3.3, 4.7.3.4		
languages for instructions and marking	1.7.12		
laser radiation (including LEDs)	0.2.6, 4.3.13.5 , annex P (IEC 60825-1)		
leakage current	1.2.13.12 (note), 1.2.13.13 (note), 5.1.7, 5.1.8.2, W.1.2		
see also	TOUCH CURRENT		
LED, light emitting diode	see laser radiation		
legal requirements	1.1.2 (note), clause 6 (note 2), clause 7 (note 2)		
see also	country notes		
levers	see handles and levers		
lightning	see transients		
limit	see EXPLOSION LIMIT and maximum		
LIMITED CURRENT CIRCUIT	1.2.8.8*, 2.4		
connection to other equipment	3.5.2		
in an OPERATOR ACCESS AREA	1.5.7.4, 2.1.1		
limited power source	2.5 , 4.7.2.1, 4.7.2.2		
LIMITER, TEMPERATURE			
see	TEMPERATURE LIMITER		

maximum			
amount of flammable liquid	4.3.12		
current to telecommunication wiring	6.3		
input current	1.6.2		
ionizing radiation	see ionizing radiation		
LIMITED CURRENT CIRCUIT levels	2.4.2		
limited power source levels	2.5		
load (mode of operation)	1.2.2.1		
output load	1.7.5		
overvoltage, assumed in this standard	2.10.3.1 (note 2), clause 6 (note 1), clause 7 (note 1), G.2.1		
ozone level	1.7.2 (note 5)		
power from TELECOMMUNICATION NETWORK 15 VA	1.4.11		
RATED VOLTAGE			
250 V for HAND-HELD EQUIPMENT	1.6.3		
600 V in Scope of this standard	1.1.1		
ringing signal level	M.2, M.3		
ripple	see ripple		
SELV CIRCUIT voltages			
normal	2.2.2		
fault condition	2.2.3		
temperature	1.4.12, 1.4.13, 4.5.1		
in an OPERATOR ACCESS AREA	4.5.1		
of			
conductor	3.1.1		
insulation during a test	5.3.8.1		
materials and components	0.2.4, 4.5.1		
motor	B.3 , B.4, B.5, B.7.1, B.8, B.9		
transformer	C.1, annex X		
winding	1.4.13, annex E		
TNV CIRCUIT voltages			
TNV-1 CIRCUIT	2.3.1 a)		
TNV-2 and TNV-3 CIRCUITS	2.3.1 b)		
TOUCH CURRENT	5.1.1, 5.1.6, 5.1.8.1, 5.1.8.2		
transient voltage	see transients		
ultraviolet radiation	4.3.13.4		
measuring instrument, electrical			
ammeter, negligible impedance	1.4.7, 1.4.9, 2.4.2, 5.1, annex D 5.1.7		
MECHANICAL ENCLOSURE	1.2.6.3*, 4.2 , 4.4		
see also ENCLOSURE, opening in an ENCLOSURE			
mechanical hazard	0.2.5, 2.8.2, 4.1		
mechanical shock			
affecting CLEARANCE	2.10.3.1 (note 6), G.6 (note 2)		
affecting a SAFETY INTERLOCK	2.8.3		
mechanical strength	4.2		
after ultraviolet radiation	4.3.13.3		
cathode ray tube	0.2.5, 4.2.8		
handles (no test)	4.2.1		
high pressure lamp	4.2.9		
in a SAFETY INTERLOCK	2.8.5, 2.8.8		
insulating materials	2.9.1		
no test in a MECHANICAL ENCLOSURE	4.2.1		
screws	3.3.3		
mechanical stress, on insulation	2.10.5.4, 3.2.7, 5.2.2		
mechanically operated part in a SAFETY INTERLOCK system	2.8.4, 2.8.5		
mechanically operated switch in a SAFETY INTERLOCK system	2.8.7		
metal			
core in printed board	2.10.5.3, 2.10.6.6		
foil	see foil, conductive		
molten	0.2.2, 4.3.8, 4.6.2, 5.3.8.1		
screen	see screen, conductive		
metal, no flammability test	4.7		
misuse, foreseeable	0.1, 5.3.1		
mobility of equipment (definitions)	1.2.3*		
moisture	see humidity and water ingress		
motor			
requirements	5.3.2		
tests	annex B		
at RATED VOLTAGE	B.2		
d.c. motor	B.1, B.6, B.7, B.10		
locked rotor	B.5		
motor with capacitors	B.8		
running overload	B.4		
series motor	B.10		
stepper motor	B.1		
three-phase motor	B.9		
motor-generator sets, not in Scope of this standard	1.1.3		
MOVABLE EQUIPMENT	1.2.3.1*, 1.2.3.2, 1.2.3.3, 1.2.3.4, 5.1.6 (table 5A)		
FIRE ENCLOSURE	4.7.3.2, A.1, A.2		
power supply cord flexing test	3.2.5.1		
movable part of equipment	1.4.4, 2.1.1.1, 2.10.3.1, 2.10.4, G.6		
see also removable part			
moving part of			
equipment	2.8.2, 3.1.2, 4.2.1, 4.4		
SAFETY INTERLOCK system	2.8.4, 2.8.5		
multiple power sources	1.7.9, 2.6.4.2, 3.2.2, 3.4.10, 3.4.11 , 5.1.2		
N			
national requirements	see country notes and legal requirements		
needle flame test	4.6.2, 4.7.3.6, annex P (IEC 60495-2-2)		
neoprene	4.7.2.2, 4.7.3.3, 4.7.3.4		
see also rubber, synthetic			
network	see TELECOMMUNICATION NETWORK		
neutral conductor	1.6.4		
disconnection by disconnect device	3.4.6, 3.4.7		
disconnection by protective device	2.7.4, 4.3.7		
earthed and reliably identified	3.4.6, 2.7.4		
fuse in neutral, warning required	2.7.6		
in power distribution system	annex V		
marking of terminals	1.7.7.2		
noise hazard (acoustic)	0.2.6		

nominal AC MAINS SUPPLY voltages		overcurrent and earth fault protection	
2.10.3.2 (tables 2H, 2J and 2K), G.2.1 (table G.1), G.4		0.2.3, 2.7, annex P (ITU-T Rec. K.21)	
NON-DETACHABLE POWER SUPPLY CORD		overcurrent protection device	
see power supply cord		CLEARANCE not applicable	2.10.3.1, G.6
NORMAL LOAD condition	1.2.2.1*, 1.6.2, 4.5.1, annex L	in limited power source	2.5
normative references	annex P	not allowed to operate	4.5.1
O		not damaged during a test	4.2.1
oil and grease	4.3.9, 4.3.12	overcurrent protection for telecommunication wiring	6.3
hot flaming oil test	A.3	overcurrent protection for transformers	5.3.3, C.1, annex X
see also liquid		unexpected restart	4.4.1
opening in an ENCLOSURE	4.6	overheating of telecommunication wiring	6.3
access to		overload	
electrical hazard	2.1.1.1, 2.1.1.2, 2.8.2	mechanical	5.3.1
mechanical hazard	2.8.2, 4.4.2	electrical	3.1.1, 5.3.1, 6.3
ultraviolet radiation	2.8.2, 4.3.13.4	see also overcurrent	
component which fills	4.7.2.2, 4.7.3.2	motor	5.3.2, B.2 (table B2), B.4, B.5, B.6, B.7
for power cord	3.2.7, 3.2.8	test	5.3.6
in bottom of an ENCLOSURE	4.6.2	transformer	5.3.3, C.1, annex X
in top and sides of an ENCLOSURE	4.6.1	overriding a SAFETY INTERLOCK	2.8.6
in TRANSPORTABLE EQUIPMENT	4.6.4	overvoltage	0.1, 2.10.1, annex P (ITU-T Rec. K.21), annex Q (ITU-T Rec. K.11)
measuring through	2.10.3.1, 2.10.4, G.6	maximum level assumed in this standard	2.10.3.1 (note 2), clause 6 (note 1), clause 7 (note 1), G.2.1
ventilation, in FIRE ENCLOSURE	4.7.3.3, 4.7.3.4, A.1.1, A.1.5, A.2.1, A.2.5	not considered	1.4.8
operating conditions (definitions)	1.2.2*	on a TELECOMMUNICATION NETWORK	see TELECOMMUNICATION NETWORK TRANSIENT VOLTAGE
operating instructions	1.2.2.1, 1.2.7.1, 1.2.7.3, 1.3.6, 1.4.4, 1.7.2, 1.7.15, 2.1.1.2, 2.3.2, 3.4.10, 3.4.11, 4.3.13.4, 4.4.2, 4.6.3 c), annex L	see also overvoltage category and transients	
OPERATION, CONTINUOUS		on TNV CIRCUITS	1.2.8.10 (table 1A), 1.2.8.11, 1.2.8.12, 1.2.8.13, 2.2.2 (note)
see CONTINUOUS OPERATION		overvoltage category	2.10.3.1 (notes 2 and 3), 2.10.3.2, 2.10.3.3, G.2.1
OPERATION, INTERMITTENT		note - the term overvoltage category has replaced the term installation category	
see INTERMITTENT OPERATION		overvoltage categories III and IV	G.2.1
OPERATION, SHORT-TIME		ozone	1.7.2
see SHORT-TIME OPERATION		P	
operational insulation	see FUNCTIONAL INSULATION	Part 68, FCC Rule	M.3 (note), annex P
note - the term FUNCTIONAL INSULATION has replaced the term operational insulation		passive devices, not in Scope of this standard	1.1.3
OPERATOR	see USER, which has the same meaning	PEAK WORKING VOLTAGE	1.2.9.7*, 2.10.3.2, 2.10.3.3, 2.10.5.1, G.1, G.4, G.6
OPERATOR ACCESS AREA	0.1, 1.2.7.1*, 2.1	PERMANENTLY CONNECTED EQUIPMENT	1.2.5.3*
access probes	2.1.1.1	discharge of capacitor	2.1.1.7
compared with a RESTRICTED ACCESS LOCATION	1.2.7.3 (note), 2.1.3	disconnect device	3.4.3
door in FIRE ENCLOSURE	4.6.3	earthing	2.3.2 (note 5), 2.6.4.2, 2.6.4.3, 6.1.2.2, 7.3.1
markings to be visible	1.7.1	marking	1.7.2, 1.7.7.2, 1.7.7.3
TOOL required for access	1.2.7.1, 1.7.16	overcurrent protection	2.7.1, 2.7.3, 2.7.6
ordinary NON-DETACHABLE POWER SUPPLY CORD	1.2.5.5	terminals	3.2.3, 3.3.1, 3.3.7
see also power supply cord		TOUCH CURRENT	5.1.1, 5.1.7
orientation (attitude)	0.1, 1.3.6, 4.6	permission to connect to a TELECOMMUNICATION NETWORK	see legal requirements
		person, network service	see SERVICE PERSON
		PERSON, SERVICE	see SERVICE PERSON
		plating, protective earthing component	2.6.5.6
		PLUGGABLE EQUIPMENT	1.7.2, 4.3.7

discharging filter capacitor	2.1.1.7	PRIMARY CIRCUIT	1.2.8.3*, 1.2.8.4
earthing	2.3.2	capacitors in	1.5.6, 2.1.1.7
isolation	3.4.2, 3.4.6	CLEARANCE in	2.10.3.2, annex G
overcurrent protection		faults in components in	5.3.6
TYPE A	1.2.5.1*, 2.1.1.7, 2.3.2, 2.6.3.3, 2.6.4.3, 2.7.3, 2.10.3.1, 5.1.6 (table 5A), 5.1.8.2, 7.3.1, G.6	filter in	0.2.1, 5.1
TYPE B	1.2.5.2*, 2.1.1.7, 2.3.2, 2.3.3 (note 1), 2.6.4.3, 2.7.1, 2.7.3, 5.1.1, 5.1.7, 5.1.8.2, 6.1.2.2, 7.3.1	internal wiring	3.1.1
plugs <i>see</i> connectors <i>and</i> mains		marking of switch	1.7.8
pollution (degree)	0.1, 2.9.1, 2.10.1, 2.10.3.2 (tables), 2.10.3.3 (table 2K), 2.10.4 (table 2L), 2.10.5.4, annex F (table F.1)	marking of terminals	1.7.7
pollution degree 1 applies	2.10.7	protection	2.7
polyimide insulating material	4.7.2.2, 4.7.3.3, 4.7.3.4	SAFETY INTERLOCK switch, contact gap	2.8.7.1, 2.8.7.4
powder	4.3.10	WORKING VOLTAGE in	2.10.2
container	4.7.3.4	<i>see also</i> mains	
power		primary power	<i>see</i> AC MAINS SUPPLY, DC MAINS SUPPLY <i>and</i> PRIMARY CIRCUIT
apparent	2.5 (tables)	principles of safety	clause 0
connection to equipment	3.2	printed boards	
from a TELECOMMUNICATION NETWORK 15 VA	1.4.11	coated	2.10.6
limited <i>see</i> limited power source		CLEARANCE <i>and</i> CREEPAGE DISTANCE	
no power required, excluded from Scope of this standard	1.1.3	2.10.6.1, annex F (figure F.11), R.1	
outlet on equipment <i>see</i> socket-outlet on equipment		distance through insulation	2.10.5.3
supplied to telecommunication wiring	6.3	metal core	2.10.5.3, 2.10.6.6
rating, marking	1.7.1 , 1.7.4	multi-layer	2.10.5.3
sources for equipment		quality control	R.1
any, included in Scope	1.1.1	printed wiring, colour of flexible	2.6.3.5
multiple <i>see</i> multiple power sources		<i>see also</i> printed boards	
power distribution system, a.c.	1.2.8.1, 1.6.1, annex V	proof tracking index (PTI) <i>see</i> tracking	
single phase, three wire	V.2 (figure V.4)	protection	
<i>see also</i> IT power distribution system, TN power distribution system <i>and</i> TT power distribution system		against electric shock and energy hazards	2.1, clause 6, clause 7
power distribution system, d.c.	1.2.8.2	against ingress of water <i>see</i> water ingress	
power supply cord	3.2.1.1, 3.2.1.2, 3.2.5.1 , 3.2.5.2	against moving parts of equipment	<i>see</i> moving parts of equipment
DETACHABLE POWER SUPPLY CORD		against overcurrent and earth faults	2.7
1.2.5.4*, 2.6.4.2, 3.2.1.1, 3.2.1.2, 3.2.5.1		backup protection	2.7.3
inside the equipment	3.1.4	provided by building installation	2.7.1, 2.7.3
marking of wiring terminals	1.7.7	in an OPERATOR ACCESS AREA	2.1.1
NON-DETACHABLE POWER SUPPLY CORD	1.2.5.5*, 3.2.1.1, 3.2.1.2, 3.2.3, 3.2.5.1, 4.5.1 (table 4B part 1)	in a RESTRICTED ACCESS LOCATION	2.1.3
connection to equipment		in a SERVICE ACCESS AREA	2.1.2
mechanical connection	3.2.6, 3.2.7, 3.2.8, 3.2.9	of a cable system equipment USER	7.1, 7.2
terminals	2.6.4.3, 3.3.1, 3.3.2, 3.3.7	of a SERVICE PERSON <i>see</i> SERVICE PERSON	
ordinary	2.10.4, 3.2.6, 3.2.9, 3.3.1, 3.3.7	of a telecommunication equipment USER	6.1, 6.2
special	2.6.4.3, 3.3.2, 3.3.8	of telecommunication wiring	6.3
PROTECTIVE EARTHING CONDUCTOR	2.6.3.2, 3.2.5.1, 3.2.6	PROTECTIVE BONDING CONDUCTOR	1.2.13.11*, 2.6.3
colour of insulation	2.6.3.5	colour of insulation	2.6.3.5
screened	3.2.5.1, 3.2.6	components not allowed in	2.6.5.2
voltage drop not measured	1.4.9, 2.6.3.4	integrity to be assured	2.6.5
power supply unit in equipment, earth terminal marking	1.7.7.1	resistance	2.6.3.4
pre-preg	2.10.5.3 (table 2M)	separation from PROTECTIVE EARTHING CONDUCTOR	2.6.4.3
		size	2.6.3.3, 3.2.5 (table 3B)
		terminals	1.7.7.1, 2.6.4.2, 3.3.5
		PROTECTIVE CONDUCTOR CURRENT	
		1.2.13.13*, 5.1.1, 5.1.7, annex P (IEC 60990)	
		protective covering in place during a test	5.3.1
		protective device	2.7

protective earthing and bonding	2.6	when determining WORKING VOLTAGE	2.10.2
corrosion resistance of conductive parts	2.6.5.6	when measuring input current	1.6.2
screws	2.6.5.7, 3.1.6, 3.3.3		
PROTECTIVE EARTHING CONDUCTOR	1.2.13.10*, 2.6.3	RATED VOLTAGE RANGE of equipment	1.2.1.2*
colour of insulation	2.6.3.5	marking	1.7.1
components not allowed in	2.6.5.2	used for test	1.4.5, 5.1.3, 6.1.2.1, B.2, annex K
in power supply cord	3.2.5.1, 3.2.6	when determining WORKING VOLTAGE	2.10.2
integrity to be assured	2.3.2, 2.6.5 , 5.1.7, 5.1.8.2 a), 6.1.1, 6.1.2.2, 7.1	when measuring input current	1.6.2
resistance	2.6.3.4	rated voltage of components	1.6.4
separation from PROTECTIVE BONDING CONDUCTOR	2.6.4.3	capacitor	1.5.7.2, 1.5.7.3, 1.5.8
size	2.6.3.2, 3.2.5 (table 3B)	fuse	1.7.6
terminal	1.7.7.1, 2.3.2, 2.6.4.2, 3.3	motor, used for test	B.6, B.10
voltage drop not measured	1.4.9, 2.6.3.4	surge suppressor	6.1.2.1
<i>see also</i> PLUGGABLE EQUIPMENT TYPE B			
PTC (positive temperature coefficient) device	2.5	redundant power supply	<i>see</i> multiple power sources
PTFE (polytetrafluoro ethylene)	4.7.2.2, 4.7.3.3, 4.7.3.4	reed switch, reliability test	2.8.7.3
PTI (proof tracking index)	<i>see</i> tracking	REINFORCED INSULATION	0.2.1, 1.2.9.5*
PVC (polyvinyl chloride)	3.2.5.1, 4.5.1 (table 4B part 1), 4.7.2.2, 4.7.3.3, 4.7.3.4, annex P (IEC 60227)	application	2.9.3, clause 6 (note 4)
		in	
		CABLE DISTRIBUTION SYSTEM	clause 7 (note 3)
		FUNCTIONAL EARTHING circuit	2.6.2
		internal wiring	2.1.1.6
		manual control	2.1.1.6
		printed board	2.10.5.3, 2.10.6, annex F (figure F.11)
		SELV CIRCUIT	2.2.3.1, 2.2.4
		TNV CIRCUIT	2.3.3, 2.3.4
		wound component	2.10.5.4, annex U
		bridging	<i>see</i> bridging of insulation
		dimensions	2.10.3, 2.10.4, 2.10.5 , annex F, G.6, R.2
		electric strength	5.2
		integrity	
		after a test	4.2.1, 5.3.4, 5.3.6, 5.3.8.2
		in service	3.1.6, 4.3.4, C.2
		protective device not needed	2.7.4
		WORKING VOLTAGE	2.10.2
		relative humidity	<i>see</i> humidity
		relays	1.5.1 (note 2)
		in a FIRE ENCLOSURE	4.7.2.1
		in a SAFETY INTERLOCK switch, contact gap	2.8.7.1, 2.8.7.4
		in a SAFETY INTERLOCK system	2.8.5 (note), 2.8.7
		motor starting	B.5
		reliability	<i>see</i> endurance testing
		remote power feeding (of telecommunication equipment)	Foreword
		<i>see also part 21 of this standard</i> , IEC 60950-21	
		removable part	1.7.14 , 2.1.2, 3.2.7, 4.6.3
		REQUIRED WITHSTAND VOLTAGE	1.2.9.8*, G.1, G.4, G.6
		requirements of this standard,	
		applicable only if safety is involved	1.3.1
		resistance, protective conductor	2.6.3.4
		resistance to fire	<i>see</i> fire hazard
Q			
quality control	2.10.3.2 (table 2H item 2), 2.10.3.3 (table 2K, item 2), 2.10.6.1, 2.10.9, G.6 (table G.2, item 2)		
quality control programme	annex R		
R			
radiation	4.3.13		
hazards	0.2.6		
ionizing	<i>see</i> ionizing radiation		
laser	<i>see</i> laser radiation		
ultraviolet	<i>see</i> ultraviolet radiation		
range			
current	1.7.1		
frequency	<i>see</i> RATED FREQUENCY RANGE		
of conductor size	3.3.4, 3.3.5		
voltage	<i>see</i> RATED VOLTAGE RANGE		
RATED CURRENT (of equipment)	1.2.1.3*		
input current not to exceed	1.6.2		
marking	1.7.1		
power supply cord current-carrying capacity	2.6.3.2, 3.2.5.1		
purpose of marking	1.7.1		
range	1.7.1		
terminal sizes	3.2.3, 3.3.4, 3.3.5		
rated current of overcurrent device	1.7.6, 2.5		
RATED FREQUENCY	1.2.1.4*, 1.4.6, 1.7.1, 1.7.4		
RATED FREQUENCY RANGE	1.2.1.5*, 1.4.6, 1.7.1, 1.7.4		
RATED OPERATING TIME	1.2.2.2*, 1.7.3, 4.5.1, 5.3.7		
RATED VOLTAGE of equipment	1.2.1.1*		
IT power distribution system	1.5.8		
marking and instructions	1.7.1, 1.7.4		
maximum value			
250 V for HAND-HELD EQUIPMENT	1.6.3		
600 V in Scope of this standard	1.1.1		
tolerance	1.4.5		
used for test	1.4.5, 1.6.2, 5.1.3, 6.1.2.1, B.2, annex K		

resistors					
bridging	see	bridging of insulation			
faults in			1.4.14, 5.3.6		
RESTRICTED ACCESS LOCATION		0.1, 1.2.7.3*, 2.1.1.1, 2.1.3			
bottom of FIRE ENCLOSURE			4.6.2		
compared with an OPERATOR ACCESS AREA			1.2.7.3 (note), 2.1.3		
installation instructions			1.7.17		
maximum temperature, exception for heat sink			4.5.1		
mechanical hazard in			4.4.3		
r.f.i.		radio frequency interference			
see		electrical filter			
ringing signal	see	telephone ringing signal			
ripple in DC VOLTAGE					
definition			1.2.13.4		
in a limited power source			2.5 (table 2B, item 1, table 2C, item 1)		
in WORKING VOLTAGE			2.10.3.2, 2.10.3.3, 2.10.4		
r.m.s. value implied unless otherwise specified			1.2		
ROUTINE TEST			1.2.13.3*		
coated printed board		2.10.6.1, R.1 (table R.1)			
distance through insulation		2.10.5.1, 2.10.5.3			
electric strength, for ROUTINE TEST		5.2.2 (note 1)			
reduced CLEARANCE		2.10.3.2 (table 2H item 2), 2.10.3.3, (table 2K, item 2), 2.10.6.1, 2.10.9, G.6 (table G2, item 2), R.2 (table R.2)			
winding wire			U.3.1		
wound component			2.10.5.4		
routing of wiring		2.1.1.3, 2.1.1.4, 2.2.3.1, 3.1.3			
rubber					
cable insulation		annex P (IEC 60245)			
natural, not to be used as insulation			2.9.1		
parts		4.5.1 (table 4B part 2)			
roller		4.7.3.3, 4.7.3.4			
synthetic, as insulation		3.1.9, 3.2.5.1, 4.5.1 (table 4B, part 1)			
running overload tests					
a.c. motor			B.4		
d.c. motor			B.6		
S					
SAFETY INTERLOCK		1.2.7.6*, 2.8			
fail-safe operation			2.8.4		
mechanical actuator		2.8.5, 2.8.8			
mechanical shock affecting			2.8.3		
not damaged during a mechanical strength test			4.2.1		
overriding a SAFETY INTERLOCK					
by a SERVICE PERSON			2.8.6		
TOOL required			2.8.6		
tests					
moving part			2.8.5		
switches and relays					
endurance			2.8.7.3		
overload			2.8.7.2		
samples for test					
components			1.5.2		
equipment		1.2.13.1, 1.2.13.2, 1.2.13.3, 1.4.3			
flammability		A.1.1, A.2.1, A.3.1			
to be as supplied to the USER			1.4.3		
SAMPLING TEST			1.2.13.2*, R.1, R.2, U.3.2		
Scope of this standard					1.1
screen					
bottom of FIRE ENCLOSURE			4.6.2, 4.7.3.5		
conductive			2.9.3 (note to table 2G)		
coaxial cable			7.2		
earthed		0.2.1, 1.4.14, 2.6.1 f), 2.10.3.3, C.2, G.4 a)			
for a FUNCTIONAL EARTHING circuit			2.6.2		
for an SELV CIRCUIT			2.2.3.2, 2.2.4		
for a TNV CIRCUIT			2.3.3, 2.3.4		
in a power supply cord			3.2.5.1, 3.2.6		
mechanical			4.2.1, 4.4.2, 4.6.4		
secured with adhesive			4.6.5		
screws, screw connections		annex P (ISO 261, ISO 262)			
for electrical contact			3.1.6, 3.1.8		
for protective earthing continuity		2.6.4.2, 2.6.4.3, 2.6.5.7, 3.1.6, 3.1.8, 3.3.1, 3.3.3, 3.3.5, 3.3.6, 3.3.8			
for securing a part			4.3.4		
into, or made of, insulating material			3.1.7, 3.2.6		
no marking on			1.7.7.1, 1.7.7.2		
self-tapping and spaced thread			2.6.5.7, 3.1.8		
terminals		1.2.5.3, 2.6.4.2, 2.6.4.3, 3.1.9, 3.3.1, 3.3.3, 3.3.5, 3.3.6, 3.3.8			
sealed, sealing					
components		2.10.1, 2.10.7, 4.7.3.3, 4.7.3.4			
compound		2.1.1.1 (note 1), 4.3.2, 4.5.1			
kit (against moisture)			annex T		
layers of insulation tape on winding wire			2.10.5.4, U.1		
liquid reservoir			4.3.12		
SECONDARY CIRCUIT		1.2.8.2, 1.2.8.4*, 1.2.8.6, 1.2.8.7, 1.2.8.10, 2.9.3			
CLEARANCE in			2.10.3.3, annex G		
FIRE ENCLOSURE			4.7.2.1, 4.7.2.2		
floating			2.10.3.3, G.4 a)		
hazardous voltage		1.5.6 (note), 2.1.3, 2.2.4, 2.3.4, 7.1			
motor in			5.3.2, B.1, B.6, B.7		
switch in			1.7.8.3		
TNV CIRCUIT			1.2.8.10		
transients in		2.10.3.2 (note 2), 2.10.3.3, G.4 a)			
WORKING VOLTAGE					
over 10 kV		5.2.2 (table 5B part 1, item 1)			
between a PRIMARY CIRCUIT and a SECONDARY CIRCUIT			2.10.2		
secondary winding overload test					C.1, annex X
securing	see	fixing			
SELV CIRCUIT			1.2.8.7*, 2.2		
accessibility			2.1.1		
barrier in			2.2.3.1		
boundary of		2.2.2 (note), 2.2.4			
CABLE DISTRIBUTION SYSTEM, excluded from			1.2.13.4		
compared with a TNV CIRCUIT			1.2.8.10 (table 1A)		
connected to a CABLE DISTRIBUTION SYSTEM			7.1		
(SELV CIRCUIT, <i>continued</i>)					
connected to a TELECOMMUNICATION NETWORK			1.4.11, 2.2.2 (note), 2.10.3.4, 6.1.1 , G.3		

connection to other circuits	2.2.4	shock, electric	see electric shock
connection to other equipment	3.5.1, 3.5.2	shock, mechanical	see mechanical shock
connectors	4.3.5	short circuit	2.7
different from the term "SELV system" in IEC 61140	1.2.8.7 (note 2)	of	
earthing	2.2.3.3, 2.6.3.4	battery	4.3.8
faults	1.2.8.7, 1.4.14, 2.2.1, 2.2.3, 2.3.1, 2.3.2	components, for a test	5.3.6
FIRE ENCLOSURE not required	1.4.11, 4.7.2.2	during servicing	2.1.2, 2.1.3
insulation	2.9.3	insulation, for test	2.2.4, 2.3.2, 2.3.4, 2.10.2, 5.3.4 c)
maximum voltages		limited power source	2.5
earthing	2.6.3.4	motor capacitor	B.8
normal conditions	1.4.8, 2.2.2, 2.3.2	telecommunication wiring	6.3
fault conditions	2.2.3, 2.3.1	temperature limiter in unattended equipment	5.3.7
separation		transformer	C.1, annex X
from an accessible part, no requirement	2.1.1	protection against	2.7, 3.1.1, 5.3.1
from a HAZARDOUS VOLTAGE	2.2.3	see also energy hazard	
from other circuits	2.9.3 (table 2G), 3.1.9, 6.2.1	SHORT-TIME OPERATION	1.2.2.4*, 1.7.3, 4.5.1, 5.3.7
TELECOMMUNICATION NETWORK, excluded from	1.2.13.8	simulated	
WORKING VOLTAGE	2.10.2	body impedance	5.1, W.1.1
semiconductor devices		conditions for test	1.4.10, 2.3.2, 2.3.4, 4.5.1, 5.1.5 (note), 5.3.1, B.2, C.1, L.6, annex T
faults	1.4.14, 5.3.6	external voltage	2.3.5
filled with insulating compound	2.10.5.1	interference	annex N
see also components and surge arrestor		<i>note - fault conditions are simulated in numerous places in this standard</i>	
separate testing (of components, sub-assemblies etc.)		sleeving as additional insulation	2.10.5.4, 3.1.4, 3.1.10
components	2.10.8, 5.2.2, 5.3.6, 6.1.2.1, 6.2.2, 6.2.2.2	around insulating beads	3.1.5
enclosed parts	2.10.7, 5.3.1	small part, flammability	4.7.3.1 (note 3), 4.7.3.3, 4.7.3.4
motors	B.2	socket	see connectors and socket-outlet
switch mode power supply unit	C.1, annex X	socket-outlet	annex P (IEC 60083, IEC 60309)
use of previous test results, preselection	1.4.15, 1.5.2, 2.9.1, 4.5.1, 4.7.3	in building installation	
separation distance under a coating		for DIRECT PLUG-IN EQUIPMENT	1.2.3.6, 4.3.6
around a terminal	2.10.9, annex F (figure F.10)	for PLUGGABLE EQUIPMENT	1.2.5.1, 1.2.5.2, 1.7.2, 7.3.1
coated printed board	2.10.6.1, 2.10.6.2, R.1	protective earthing connection required	6.1.2.2
SERVICE ACCESS AREA	1.2.7.2*	reversible	3.4.6, 4.3.7
see also RESTRICTED ACCESS LOCATION and SERVICE PERSON		on equipment	1.7.5
service manual	see servicing instructions	accessibility	2.1.1.1
SERVICE PERSON	0.1, 1.2.13.5*	load to be taken into account	1.4.10, 5.3.6
connectors accessible to	4.3.5	solenoid	see wound component
of a CABLE DISTRIBUTION SYSTEM	7.1	solid insulation	2.10.1, 2.10.3.1 (note 3), 2.10.5
of a TELECOMMUNICATION NETWORK	5.1.8.2, 6.1	electric strength	5.2
overriding a SAFETY INTERLOCK	2.8.6	formed by insulating compound	2.10.8
protection	1.1.1	meaning of term	2.10.5 (note 1)
from		see also distance through insulation	
mechanical hazard	4.1, 4.4.3, 4.4.4	solvent-based enamel	see enamel
unearthed part	2.6.1	special NON-DETACHABLE POWER SUPPLY CORD	1.2.5.5
unexpected hazard	2.1.2, 2.1.3, 3.4.4	see also power supply cord	
warning notices	1.7.9, 2.6.1, 2.7.6, 3.4.10		
see also RESTRICTED ACCESS LOCATION			
servicing instructions	0.1, 1.7.2		
available only to SERVICE PERSON	1.7.2 (note 3)		
battery	1.7.15		
disconnection	1.7.2, 1.7.9, 2.6.5.5, 3.4.1 (note), 3.4.10, 3.4.11		
fuse in neutral, warning required	2.7.6		
fuse rating	1.7.6		
languages	1.7.12		
supply voltage adjustment	1.7.4, 4.3.3		
ultraviolet radiation warning	4.3.13.4		
see also SERVICE PERSON			
sheath (of power supply cord)	3.1.4, 3.2.5.1, 3.2.7		
shield,	see screen, conductive		

stability			in a FIRE ENCLOSURE	4.7.2.1, 4.7.3.2
of operation, thermal control	K.6		in a PRIMARY CIRCUIT	5.3.6
physical	4.1		isolating	3.4.2, 3.4.5, 3.4.8
stand-by condition, marking	1.7.8.3		marking	1.7.8.1, 1.7.8.2, 1.7.8.3, 4.3.2
STATIONARY EQUIPMENT	1.2.3.4*, 4.5.1 (table 4A part 1)		microgap, CLEARANCE not applicable	2.10.3.1, G.6
ENCLOSURE	4.7.3.2		momentary contact	4.7.2.2
flammability	A.1		reed, reliability test	2.8.7.3
marking	1.7.1, 4.6.2		SAFETY INTERLOCK	2.8.3, 2.8.7, 4.3.13.4
temperature of earthing terminal	4.5.1 (table 4A part 1)		terminals of	3.3.3
TOUCH CURRENT	5.1.7		thermal control	annex K
steady force test when measuring CLEARANCE	2.10.3.1, G.6		switch mode power supply	G.1 (note)
steady force test, 10 N	3.1.5, 3.1.9, 4.2.1, 4.2.2		testing	C.1, annex X
steady force test, 30 N	4.2.1, 4.2.3		symbols, marking	1.7.1, 1.7.7.1, 1.7.8.3, 1.7.11, 1.7.16, 2.6.2, 2.7.6, 4.3.13.4
steady force test, 250 N	4.2.1, 4.2.4		<i>see also</i> ISO 7000 <i>and</i> IEC 60417	
steel ball impact test	4.2.1, 4.2.5			
strain relief			T	
on fluid container	4.3.11		TELECOMMUNICATION NETWORK	1.2.13.8*
on power cord	3.2.6		connected to an SELV CIRCUIT or a TNV CIRCUIT	
stranded conductor	1.2.5.5, 3.1.9, 3.3.8		1.2.13.8 (note 1), 1.4.8, 2.2.2 (note), 6.1.1	
stress, mechanical, on insulation	2.10.5.4		connections to	1.2.11.6, 1.4.11, clause 6, W.2
stress relief test on plastic material	4.2.1, 4.2.7		earthing requirements	2.6 (note), 6.1.1
subassembly testing <i>see</i> separate testing			equipment powered from,	
			included in Scope of this standard	1.1.1
			not a reliable earth	2.6.5.8
			operating voltage generated in	0.2.1, 2.3.2, 2.3.5, 2.10.4
			<i>see also</i> telephone ringing signal	
			power limit 15 VA	1.4.11
SUPPLEMENTARY INSULATION	0.2.1, 1.2.9.3*, 1.2.9.4, 1.2.9.5 (note)		separation from	
application	2.1.1.6, 2.9.3		earth	6.1.2
as sleeving	3.1.4, 3.1.10		hazardous voltage	6.1.1
in			parts of equipment	6.2
cord anchorage	3.2.6		surge protection	6.1.2.1 (figure 6A)
cord guard	3.2.7		TOUCH CURRENT, to and from	2.6.1 g), 2.6.3, 5.1.8
internal wiring	2.1.1.3			
manual control	2.1.1.6		TELECOMMUNICATION NETWORK TRANSIENT VOLTAGE	
power supply cord	3.1.4		1.2.8.10 (table 1A), 1.2.8.11, 1.2.8.12, 1.2.8.13,	
printed board	2.10.6, annex F (figure F.11)		1.2.9.10*, 1.2.13.8 (note 2), 1.4.8, 2.10.3.3, G.1, G.3 , G.4	
SELV CIRCUIT	2.2.3		measuring reduced level	2.10.3.4 b), G.5 b)
wound component	2.10.5.4		telecommunication wiring, protection	6.3
bridging <i>see</i> bridging of insulation			telegraph signals, not considered	2.3.1 (note 4)
consequences of failure	2.2.3, 2.4.1		telephone ringing signal	annex M
dimensions	2.10.3, 2.10.4, 2.10.5 , annex F, G.1 (note), G.6, R.2		considered as operating voltage	0.2.1, 1.4.8
electric strength	5.2		disregarded for CREEPAGE DISTANCE	2.10.4
integrity			frequency	M.2 (note), M.3.1.1
after a test	4.2.1, 5.3.4, 5.3.6, 5.3.8.2		in a RESTRICTED ACCESS LOCATION	2.1.3
in service	3.1.6, 3.3.8, 4.3.4		maximum level	2.3.1 b), M.2, M.3
interchanged with BASIC INSULATION	2.9.3		television distribution system <i>see</i> CABLE DISTRIBUTION SYSTEM	
one element of DOUBLE INSULATION	2.10.2, 5.2.2, 5.3.8.2		temperature	
WORKING VOLTAGE	2.10.2		ambient during a test	1.4.4, 1.4.12, 2.9.2, 3.2.8, annex E, U.2
surge arrester, surge suppressor	2.6.1 f), 2.10.3.4, 5.2.2 (note 3), clause 6 (note 1), 6.1.2.1, figure 6A, 6.2.2.2, 6.2.2.3, G.5, annex S		applied to part under test	2.9.1, 2.10.6.3, 2.10.6.4, 2.10.7, 2.10.8, 4.2.7, 4.5.2, 4.6.5, 5.2.1
<i>see also</i> component - removal during a test <i>and</i> separate testing			conditioning	4.6.5, A.1.2, A.2.2
switch			extreme	1.1.2
arcing	4.7.3.2		hazard	0.2.3, 0.2.4, 2.9.1
as disconnect device <i>see</i> disconnection for servicing			(temperature, <i>continued</i>)	
for an appliance <i>see</i> IEC 61058-1			heat sink	4.5.1
forbidden in PROTECTIVE EARTHING CONDUCTORS <i>and</i> PROTECTIVE BONDING CONDUCTORS	2.6.5.2		maximum <i>see</i> maximum temperature	
functional	3.4.2		measurement	1.4.12, 1.4.13, 4.5.1

winding	annex E	thermal cycling	2.10.5.3 (table 2M), 2.10.6.3, 2.10.7, 2.10.8, R.1
<i>note - temperature measurements are required in numerous places in the standard</i>		thermal requirements	4.5
TEMPERATURE LIMITER	1.2.11.2*, 1.5.3, 1.7.11, 5.3.7, annex K	thermoplastic part	4.2.7, 4.5.1, 4.5.2
operate during a test	4.5.1	THERMOSTAT	
terminals	see wiring terminals	1.2.11.1*, 1.4.4, 1.5.3, 1.7.11, 4.3.7, 5.3.7, annex K	
test, testing		contact gap, CLEARANCE not applicable	2.10.3.1, G.6
see also tests, specific and separate testing		not to operate during heating test	4.5.1
applicable only if safety is involved	1.4.1	thickness (of insulation)	see distance through insulation
checking compliance using previous test results	1.4.15	thin sheet insulating material	2.10.5.2 , 2.10.5.3 (table 2M), 2.10.5.4, C.2
choice of methods of test	1.3.7	electric strength testing	5.2.1
endurance	see endurance testing	pregreg, layers counted before curing	2.10.5.3 (table 2M)
equipment not operational after a test	1.4.1	three-phase	
general conditions	1.4	disconnect device	3.4.7
reliability	see endurance testing	equipment	
ROUTINE	see ROUTINE TEST	protection	2.7.4 (tables)
samples	see samples for test	TOUCH CURRENT	5.1.3, 5.1.5, 5.1.7, 5.1.8.1
SAMPLING	see SAMPLING TEST	motor	B.9
test finger	2.1.1.1 (figure 2A), annex F (figure F.12)	power distribution system	annex V
<i>note - test fingers are specified for checking access in numerous places in this standard</i>		rotation, marking if critical	1.7.7.2
test pin	2.1.1.1 and figure 2B	TIME, RATED OPERATING	see RATED OPERATING TIME
test probe	2.1.1.1 and figure 2C, 6.2.1 b)	TN power distribution system	1.6.1, 5.1, V.2
TYPE	see TYPE TEST	protective device	2.7.4 (tables)
tests, specific		TNV CIRCUIT	1.2.8.10*, 2.3
abnormal conditions	5.3	accessibility	2.1.1.1, 2.1.1.6, 2.1.2, 2.1.3
abrasion resistance	2.10.6.6, 2.10.9	in battery compartment	2.1.1.2
adhesive ageing	4.6.5	via another circuit	6.2.1
ball pressure	4.5.2	boundary of	2.3.4
current supplied to telecommunication wiring	6.3	compared with an SELV CIRCUIT	1.2.8.10 (table 1A)
drop	4.2.1, 4.2.6	connected to a CABLE DISTRIBUTION SYSTEM	7.1
durability of marking	see markings - durability	connected to an SELV CIRCUIT	2.3.2
flammability	A.1, A.2	connected to a TELECOMMUNICATION NETWORK	1.4.11, 6.1.1
electric strength	see electric strength test	connection to other circuits	2.3.4
glow wire	4.7.3.1, annex P (IEC 60695-2-1/1)	connection to other equipment	3.5.1, 3.5.2
hot flaming oil	4.6.2, A.3	connectors	4.3.5
hot wire ignitability	4.7.3.2	considered to be a SECONDARY CIRCUIT	1.2.8.10
ignition	4.6.4, 4.7, A.3	earth required	2.6.1
impact	4.2.1, 4.2.5, 4.3.13.3	FIRE ENCLOSURE not required	1.4.11, 4.7.2.2
implosion test (cathode ray tubes)	4.2.8	insulation	2.9.3
impulse	see impulse test	maximum voltages	2.3.1
mechanical strength	see mechanical strength	separation	
needle flame	see needle flame test	from accessible part	2.3.2
stability	see stability - physical	from HAZARDOUS VOLTAGE	2.3.3, 3.1.9
steady force, 10 N	3.1.5, 3.1.9, 4.2.1, 4.2.2	from an SELV CIRCUIT and from other TNV CIRCUITS	2.3.2, 2.9.3 (table 2G)
steady force, 30 N	4.2.1, 4.2.3	WORKING VOLTAGE	2.10.1, 2.10.3.2, 2.10.4
steady force, 250 N	4.2.1, 4.2.4	TNV-1 CIRCUIT	1.2.8.11*, 2.3.1 a)
steel ball impact	4.2.1, 4.2.5	separation from parts of equipment	6.2.1
stress relief on plastic material	4.2.1, 4.2.7	treated as a TNV-3 CIRCUIT	2.3.2
surge	7.3.2	TNV-2 CIRCUIT	1.2.8.12*, 2.3.1 b)
thermal ageing	see thermal ageing	treated as a TNV-3 CIRCUIT	2.3.2
thermal cycling	see thermal cycling	TNV-3 CIRCUIT	1.2.8.13*, 2.3.1 b)
TOUCH CURRENT	5.1	separation from parts of equipment	6.2.1
transient voltage	2.10.3.4, G.5	tolerances	
TFE (tetrafluoro ethylene)	4.7.2.2, 4.7.3.3, 4.7.3.4	frequency	1.4.6
thermal ageing	2.10.5.3 (table 2M, item 1), 2.10.6.4, R.1	voltage	1.4.5
THERMAL CUT-OUT	1.2.11.3*, 1.5.3, 4.3.7, 5.3.1, 5.3.2, 5.3.3, 5.3.7, B.2, C.1, annex K, annex X	during TOUCH CURRENT tests	5.1.3
AUTOMATIC RESET	1.2.11.4*, 4.4.1		
contact gap, CLEARANCE not applicable	2.10.3.1, G.6		
integrity after a test	4.2.1		
MANUAL RESET	1.2.11.5*		
not to operate during heating test	4.5.1		

TOOL	1.2.7.4*	transient rating (Overvoltage Category II)	2.10.3.2 (table 2H), 2.10.3.3 (table 2K)
not required for an OPERATOR ACCESS AREA	1.2.7.1	transients	
required for		affecting WORKING VOLTAGE	1.2.9.7, 2.10.1, 2.10.2
access	1.2.7.3, 1.7.16, 3.2.9	attenuated	2.6.1 f), 2.10.3.4, G.5, clause 6 (note 1), clause 7 (note 1)
adjustment	1.4.4, 4.3.3	disregarded for CREEPAGE DISTANCE	2.10.4
replacement of special cord	1.2.5.5	in PRIMARY CIRCUIT	1.2.9.9, 2.10.3.2, 2.10.3.3, G.1, G.4 a)
required to		in SECONDARY CIRCUIT	2.10.3.3, G.1, G.4 a)
open a battery compartment	2.1.1.2	in TNV CIRCUIT	1.2.8.11, 1.2.8.12, 1.2.8.13
override a SAFETY INTERLOCK	2.8.6	not part of operating voltage	1.4.8
remove a bushing	3.2.7	internally generated	2.10.3.3, G.1, G.4 a)
remove a guard against water ingress	annex T	measurement in a floating SECONDARY CIRCUIT	2.10.3.4, G.5
risk of short-circuit during servicing	2.1.2	non-repetitive, not affecting WORKING VOLTAGE	2.10.3.2
		on a TELECOMMUNICATION NETWORK	
		see TELECOMMUNICATION NETWORK TRANSIENT VOLTAGE	
TOUCH CURRENT	0.2.1, 1.2.13.12*, 5.1, annexes D and W	simulated	annex N
high TOUCH CURRENT	5.1.7, 5.1.8.2 a)	see also impulse test, MAINS TRANSIENT VOLTAGE and overvoltage category	
maximum	5.1.6, 5.1.8.1, 5.1.8.2	transport	
measuring instruments	annex D	castors	1.2.3.1, 4.1
summation	5.1.8.2, annex W	conditions during	2.6.5.6
to and from a TELECOMMUNICATION NETWORK	2.6.1 g), 2.6.3, 5.1.8	orientation	1.3.6
		precautions during	1.7.2
		TRANSPORTABLE EQUIPMENT	
		0.1, 1.2.3.3*, 4.2.6, 4.6.1, 4.6.4, 5.1.6 (table 5A)	
tracking	2.10.1, 2.10.4, annex P (IEC 60112)	orientation	1.3.6
transformer	1.5.4, annex C	TT power distribution system	1.6.1, S.1, V.3
conductive foil as screen	C.2 (note)	protective device	2.7.4 (tables)
core	2.9.3 (note to table 2G), C.2	TYPE TEST	1.2.13.1*, 1.4.2, 1.4.15, 1.5.2, 2.10.5.3 (table 2M), 2.10.5.4, U.2
enclosed	2.10.7		
ferro-resonant	C.1, annex X	U	
high voltage	4.7.3.6	ultraviolet radiation	0.2.6
in FIRE ENCLOSURE	4.7.2.1	effect on materials	4.3.13.3, annex Y
in TOUCH CURRENT testing	5.1.3	human exposure	4.3.13.4
insulation	2.9.3, 2.10.2, C.2	unattended equipment, testing	5.3.7
varying dimensions	2.10.10, 5.2.2	unearthed (floating)	2.10.1, 2.10.2, annex F (figure F.13)
isolating	1.2.8.3, 1.2.8.4	ENCLOSURE	4.2.1
in limited power source	2.5	EUT during TOUCH CURRENT tests	5.1.3
in SELV CIRCUIT	2.2.4	meaning of term	2.9.3 (note to table 2G), 2.10.2
in TNV CIRCUIT	2.3.3	neutral in 3-phase system	2.7.4 (table 2F)
used for test	5.1.3	parts and windings	
maximum temperature	C.1, annex X	1.4.9, 2.10.1, 2.10.2, 6.2.1, annex F (figure F.13)	
not in Scope of this standard		accessibility	2.1.1.1, 2.1.1.3, 2.1.1.4
unless integral in equipment	1.1.3	in determination of WORKING VOLTAGE	2.10.2, G.4
overload protection	5.3.3, C.1, annex X	separation	2.1.1.1
power distribution	V.1	from internal wiring	2.1.1.3, 2.1.1.4
screen see screen, conductive		from stranded wire	3.3.8
signal	clause 6 (note 4), 6.2.2, clause 7 (note 3), W.2.1	TOUCH CURRENT test	5.1.5, annex W
tandem	2.2.3.1	within DOUBLE INSULATION	2.9.3
testing	2.10.7, 5.3.6, C.1, annex X	SECONDARY CIRCUIT	
winding wire see winding wire		treated as a PRIMARY CIRCUIT	2.10.3.3, 6.4
WORKING VOLTAGE	2.10.2	SELV CIRCUIT	2.6.3.4, 2.9.3
		uninsulated conductors and parts	2.1.1.1, 3.2.9
		see also busbar	
		USER	0.1, 0.2.1, 1.2.3.3, 1.2.13.6*, 1.2.13.7
		(or OPERATOR which has the same meaning)	
		handling equipment	
		battery	4.3.8

(USER - handling equipment *continued*)

high pressure lamp	4.2.9
insulation	2.10.5.2
screws	3.1.8
stability	4.1
switch	4.7.2.2
information supplied to	<i>see</i> operating instructions
of cable distribution equipment	7.1, 7.2
of telecommunication equipment	6.1, 6.2

V

vapour 0.2.7, 1.2.12.15, 4.3.12

vibration *see* mechanical shock

voltage

equipment to be safe at any supply voltage	1.3.3
for tests	1.4.5
generated externally	1.4.8, 2.3.5
steady-state, not covered by this standard	1.4.8 (note)
measurement to earth	1.4.9
normal operating	1.4.8
rating	<i>see</i> rated voltage of components
r.m.s. value implied unless otherwise specified	1.2
selector	1.7.1, 1.7.4, 4.3.3
SELV CIRCUIT and TNV CIRCUIT compared	1.2.8.10 (note 2 and table 1A)

VOLTAGE, HAZARDOUS *see* HAZARDOUS VOLTAGEVOLTAGE, RATED *see* RATED VOLTAGEVOLTAGE, REQUIRED WITHSTAND
see REQUIRED WITHSTAND VOLTAGEVOLTAGE, WORKING *see* WORKING VOLTAGE**W**

wall-mounted equipment 1.2.3.5, 4.2.10, annex T

warning notices

examples for reduction of hazards	0.1, 0.2.4, 0.2.5, 0.2.6, 0.2.7
high TOUCH CURRENT	5.1.7, 5.1.8.2 a)
moving part	4.4.2
symbol, electric shock hazard	1.7.16, 2.7.6
symbol, ultraviolet radiation	4.3.13.4
temperature	4.5.1 (table 4A item 6)
to SERVICE PERSON	1.7.9, 2.6.1, 2.7.6, 3.4.10, 4.3.13.4

water ingress 1.1.2, 2.10.7, 2.10.8, annex T

weight *see* mass

wire, wiring

clause 3

access to, in	
an ELV CIRCUIT	2.1.1.3
a HAZARDOUS VOLTAGE circuit	2.1.1.4
fixed	<i>see</i> fixing of parts - wiring
enamelled	<i>see</i> enamel
equipment	3.1.4
gauge (AWG, cmil)	2.6.3.3 (table 2D), 3.2.5.1 (table 3B)

insulation	
colour	2.6.3.5
flammability	4.7.3.3, 4.7.3.4
in FIRE ENCLOSURE	4.7.2.1, 4.7.2.2
resistance to oil	4.3.9
overcurrent protection	2.7 , 3.1.1
physical protection	2.10.5.4, 3.1.2 , 3.1.3, 4.3.13.3
printed	2.6.3.4, annex F (figure F.11)
sleeved	<i>see</i> sleeving as additional insulation
stranded	3.3.8
telecommunication	6.3
temperature	4.5.1
terminals	<i>see</i> wiring terminals
termination	3.1.9, C.2
winding	2.10.5.4, annex U
	<i>see also</i> current-carrying capacity <i>and</i> building installation

wiring terminals	1.7.7 , 2.6.4, 3.1 , 3.2.1, 3.2.3, 3.3
access	3.2.9
corrosion	2.6.5.6
current-carrying capacity	2.6.4.2, 3.3.4, 3.3.5
grouping	3.3.7
(main) protective earthing terminal	1.2.13.10, 1.2.13.11, 1.4.9, 2.2.3.3, 2.3.2, 2.3.3, 2.6.1, 2.6.3.4, 2.6.4.2 , 2.6.4.3, 5.1.3, 5.1.5, 5.1.6 (table 5A), 5.1.8.2
equipment with	5.1.7, 5.1.8.1, G.4 a)
equipment without	2.6.2, 5.1.8.1
of transformer	C.2
more than one	2.6.4.2
marking	
power supply	1.7.7.2, 1.7.7.3
protective earthing	1.7.7.1
temperature	4.5.1 (table 4A part 1)
WORKING VOLTAGE	1.2.9.6*
determination of	1.4.8, 2.10.1 , 2.10.2
for CLEARANCE in a PRIMARY circuit	2.10.3.2
for CLEARANCE in a SECONDARY circuit	2.10.3.3
for CREEPAGE DISTANCE	2.10.3.3, 2.10.4
for electric strength test	5.2.2
meaning, for DOUBLE INSULATION	2.10.2
PEAK	<i>see</i> PEAK WORKING VOLTAGE
to be considered	2.9.1, 2.9.3 (items 2 and 3)
varying	2.10.10
	<i>see also</i> rated voltage of components
wound component	2.10.5.4 , 4.7.1, 5.3.5, annex U
	<i>see also</i> motor <i>and</i> transformer

Xx-ray *see* ionizing radiation



Standards Survey

The IEC would like to offer you the best quality standards possible. To make sure that we continue to meet your needs, your feedback is essential. Would you please take a minute to answer the questions overleaf and fax them to us at +41 22 919 03 00 or mail them to the address below. Thank you!

Customer Service Centre (CSC)

International Electrotechnical Commission

3, rue de Varembé
1211 Genève 20
Switzerland

or

Fax to: **IEC/CSC** at +41 22 919 03 00

Thank you for your contribution to the standards-making process.

A Prioritaire

Nicht frankieren
Ne pas affranchir



Non affrancare
No stamp required

RÉPONSE PAYÉE

SUISSE

Customer Service Centre (CSC)
International Electrotechnical Commission
3, rue de Varembé
1211 GENEVA 20
Switzerland





Enquête sur les normes

La CEI ambitionne de vous offrir les meilleures normes possibles. Pour nous assurer que nous continuons à répondre à votre attente, nous avons besoin de quelques renseignements de votre part. Nous vous demandons simplement de consacrer un instant pour répondre au questionnaire ci-après et de nous le retourner par fax au +41 22 919 03 00 ou par courrier à l'adresse ci-dessous. Merci !

Centre du Service Clientèle (CSC)

Commission Electrotechnique Internationale

3, rue de Varembé

1211 Genève 20

Suisse

ou

Télécopie: **CEI/CSC** +41 22 919 03 00

Nous vous remercions de la contribution que vous voudrez bien apporter ainsi à la Normalisation Internationale.

A Prioritaire

Nicht frankieren
Ne pas affranchir



Non affrancare
No stamp required

RÉPONSE PAYÉE

SUISSE

Centre du Service Clientèle (CSC)

Commission Electrotechnique Internationale

3, rue de Varembé

1211 GENÈVE 20

Suisse



