

Synchronous Boost DC/DC Regulator HX3001

Features

- Up to 96% Efficiency
- Low voltage start-up: 0.9V
- Shut-down current: < 1 μ A
- Input voltage: 0.6V~4.4V
- Output voltage: 2.5V~4.3V (Up to 5V with Schottky)
- Low switch on resistance $R_{DS(ON)}$, Internal switch: 0.35 Ω
- 1.4MHz fixed frequency switching
- High switch on current: 1A
- Short-Circuit protection
- Low profile SOT-23-6 package (lead-free packaging is now available)

Applications

- Digital cameras and MP3
- Palmtop computers / PDAs
- Cellular phones
- Wireless handsets and DSL modems
- PC cards
- Portable media players

Description

The HX3001 is high efficiency synchronous, PWM step-up DC/DC converters optimized to provide a high efficient solution to medium power systems. The devices work under the input voltage between 0.6V and 4.4V with a 1.4MHz fixed frequency switching. These features minimizes overall solution footprint by allowing the use of tiny, low profile inductors and ceramic capacitors.

The HX3001 is capable of supplying an output voltage between 2.5V and 4.3V, the internal synchronous switch is desired to provide high efficiency without Schottky.

The devices also featured providing up to 260mA from a single AA cell input or up to 600mA from a 2-cell AA with a 3V/3.3V output.

The HX3001 regulators are available in the industry standard SOT-23-6 power packages (or upon request).

Typical Application

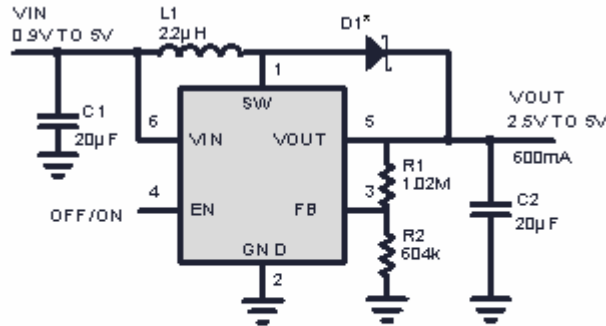

*LOCATE COMPONENTS CLOSE TO THE PIN
 C1: TAIYO YUDEN X5R JMK212BJ206MM
 C2: TAIYO YUDEN X5R JMK212BJ206MM
 D1: MOTOROLA MBR0520L
 L1: COILCRAFT D0160C-222

Pin Assignment

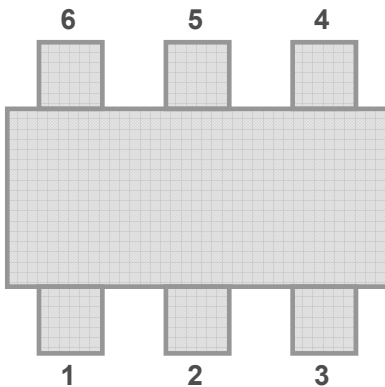

PIN NUMBER SOT-23-6	PIN NAME	FUNCTION
1	SW	Switch Output
2	GND	Ground
3	FB	Feedback
4	EN	ON/OFF Control (High Enable)
5	V _{OUT}	Output
6	V _{IN}	Input

Order Information

HX3001 - ① ② :

SYMBOL	DESCRIPTION
①	Denotes Output voltage: A : Adjustable Output
②	Denotes Package Types: F: SOT-23-6

Functional Diagram

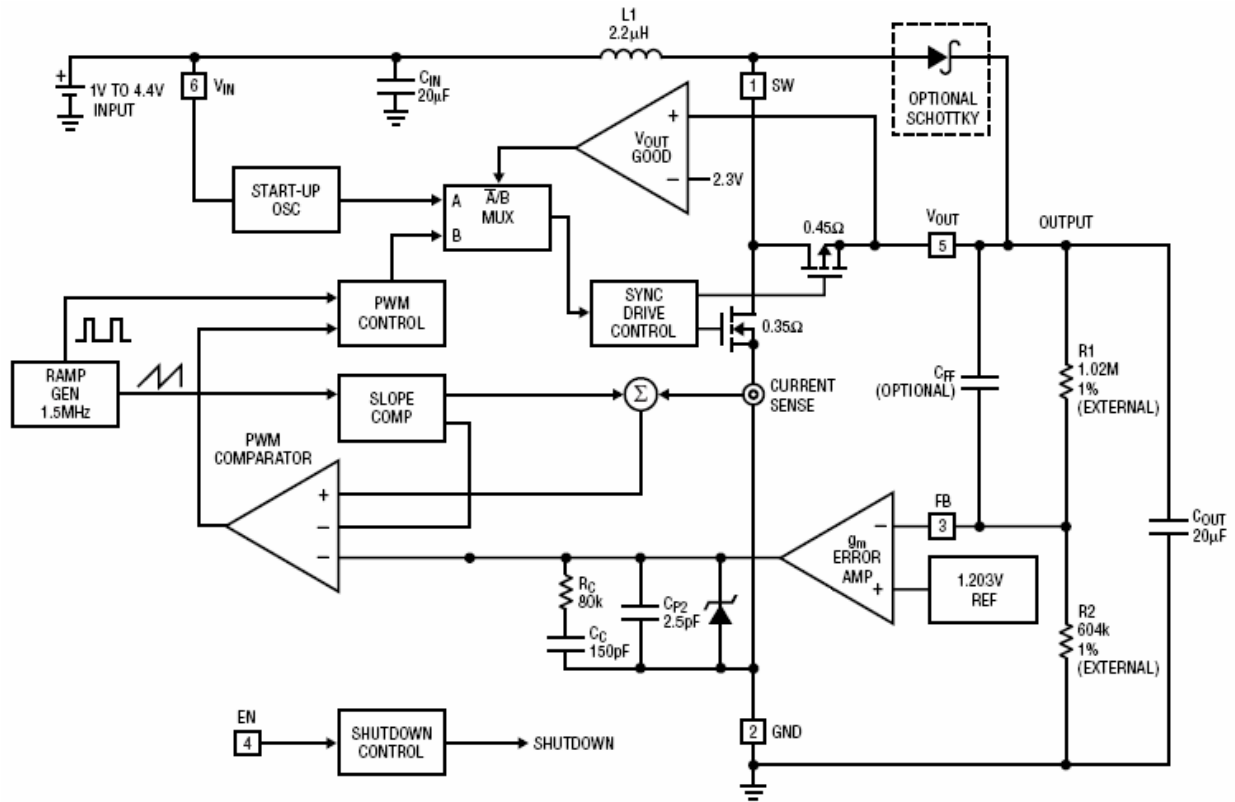

Absolute Maximum Ratings

- Power Dissipation.....Internally limited
- V_{IN} - 0.3 V ~ + 6 V
- V_{OUT} - 0.3 V ~ + 6 V
- V_{SW} - 0.3 V ~ + 6 V
- V_{EN}, V_{OUT} - 0.3 V ~ + 6 V
- Operating Temperature Range - 30°C ~ + 85°C
- Lead Temperature (Soldering 10 sec.) + 300°C
- Storage Temperature Range - 65°C ~ + 125°C

Electrical Characteristics

Operating Conditions: $T_A=25^{\circ}\text{C}$, $V_{IN}=1.2\text{V}$, $V_{OUT}=3.3\text{V}$ unless otherwise specified.

PARAMETER	CONDITIONS	MIN	TYP	MAX	UNITS
Output Voltage Range (Adj.)		2.5		5	V
Minimum Start-Up Voltage	$I_{LOAD} = 1\text{mA}$		0.9	1.1	V
Minimum Operating Voltage	$EN = V_{IN}$		0.6	0.75	V
Switching Frequency		1.1	1.4	1.7	MHz
Max Duty Cycle	$V_{FB} = 1.15\text{V}$	80	87		%
Current Limit Delay to Output			40		ns
Feedback Voltage		1.165	1.203	1.241	V
Feedback Input Current	$V_{FB} = 1.22\text{V}$		1		nA
NMOS Switch Leakage	$V_{SW} = 5\text{V}$		0.1	5	μA
PMOS Switch Leakage	$V_{SW} = 0\text{V}$		0.1	5	μA
NMOS Switch On Resistance	$V_{OUT} = 3.3\text{V}$		0.35		Ω
PMOS Switch On Resistance	$V_{OUT} = 3.3\text{V}$		0.45		Ω
NMOS Current Limit		700	950		mA
Quiescent Current (Active)	Measured On V_{OUT} , Nonswitching		300	500	μA
Shutdown Current	$V_{EN}=0\text{V}$, Including Switch Leakage		0.1	1	μA
En Input High		1			V
En Input Low				0.35	V
En Input Current	$V_{EN} = 5.5\text{V}$		0.01	1	μA

Typical Performance Characteristics

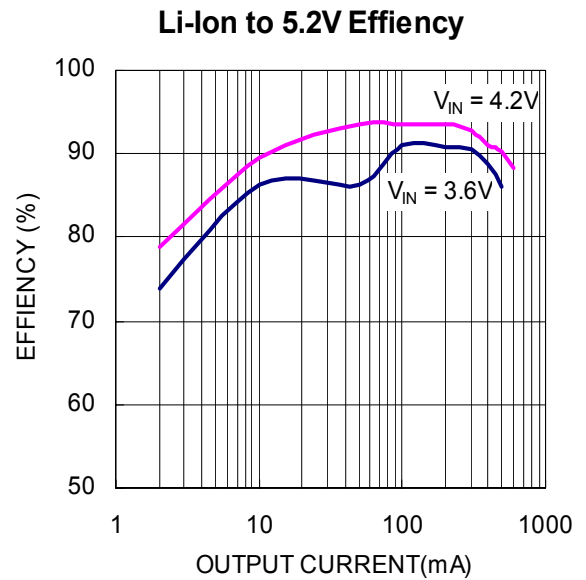
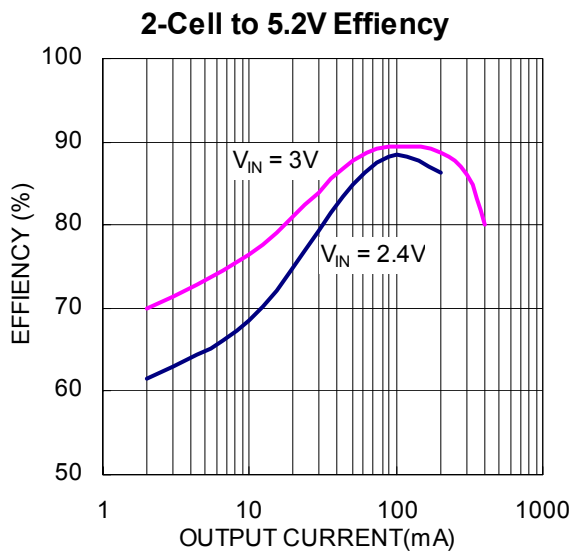
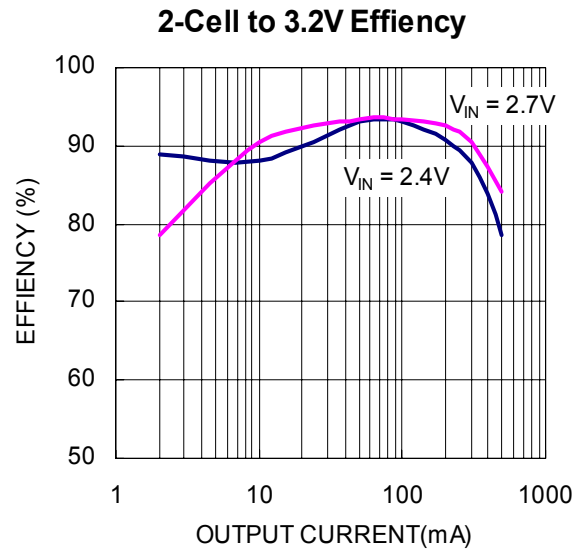
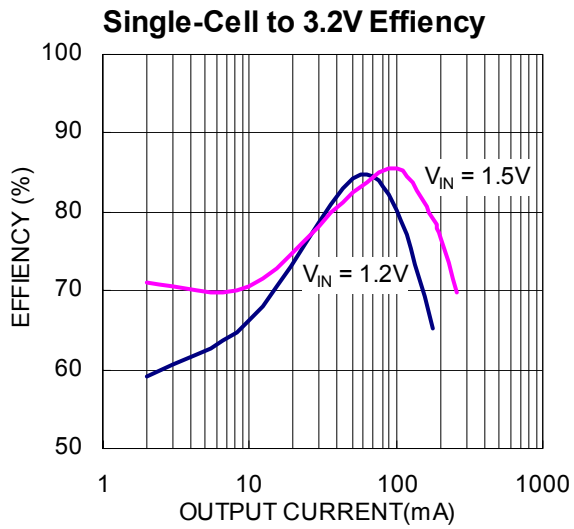

Application Information

PIN ASSIGNMENT

SW (Pin 1): Switch Pin. Connect inductor between SW and V_{IN} . Keep these PCB trace lengths as short and wide as possible to reduce EMI and voltage overshoot.

GND (Pin 2): Signal and Power Ground. Provide a short direct PCB path between GND and the (–) side of the output capacitor(s).

FB (Pin 3): Feedback Input to the g_m Error Amplifier. Connect resistor divider tap to this pin. The output voltage can be adjusted from 2.5V to 5V by: $V_{OUT} = 1.203V \cdot [1 + (R1/R2)]$

EN (Pin 4): Logic Controlled Shutdown Input. EN = High: Normal free running operation, 1.5MHz typical operating frequency. EN = Low: Shutdown, quiescent current $<1\mu A$. Output capacitor can be completely discharged through the load or feedback resistors.

V_{OUT} (Pin 5): Output Voltage Sense Input and Drain of the Internal Synchronous Rectifier MOSFET. Bias is derived from V_{OUT} . PCB trace length from V_{OUT} to the output filter capacitor(s) should be as short and wide as possible.

V_{IN} (Pin 6): Battery Input Voltage. The device gets its start-up bias from V_{IN} . Once V_{OUT} exceeds V_{IN} , bias comes from V_{OUT} . Thus, once started, operation is completely independent from V_{IN} . Operation is only limited by the output power level and the battery's internal series resistance.

PCB LAYOUT GUIDELINES

The high speed operation of the HX3001 demands careful attention to board layout. You will not get advertised performance with careless layout. Figure 2 shows the recommended component placement. A large ground pin copper area will help to lower the chip temperature. A multilayer board with a separate ground plane is ideal, but not absolutely necessary.

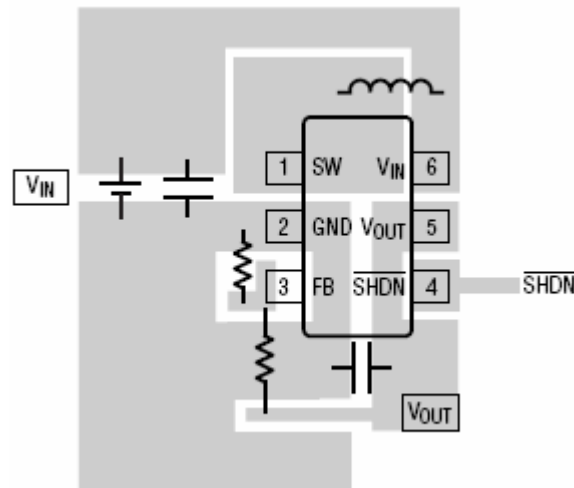

Figure 2. Recommended Component Placement for Single Layer Board

INDUCTOR SELECTION

The HX3001 can utilize small surface mount and chip inductors due to its fast 1.5MHz switching frequency. Typically, a 2.2μH inductor is recommended for most applications. Larger values of inductance will allow greater output current capability by reducing the inductor ripple current. Increasing the inductance above 10μH will increase size while providing little improvement in output current capability.

$$I_{OUT(MAX)} = \eta \cdot \left(I_P - \frac{V_{IN} \cdot D}{f \cdot L \cdot 2} \right) \cdot (1 - D)$$

where:

η = estimated efficiency

I_P = peak current limit value (0.6A)

V_{IN} = input (battery) voltage

D = steady-state duty ratio = $(V_{OUT} - V_{IN})/V_{OUT}$

f = switching frequency (1.5MHz typical)

L = inductance value

The inductor current ripple is typically set for 20% to 40% of the maximum inductor current (I_P). High frequency ferrite core inductor materials reduce frequency dependent power losses compared to cheaper powdered iron types, improving efficiency. The inductor should have low ESR (series resistance of the windings) to reduce the I^2R power losses, and must be able to handle the peak inductor current without saturating. Molded chokes and some chip inductors usually do not have enough core to support the peak inductor currents of 850mA seen on the HX3001. To minimize radiated noise, use a toroid, pot core or shielded bobbin inductor. See Table 1 for some suggested components and suppliers.

Table 1. Recommended Inductors

PART	L (μ H)	MAX DCR m Ω	MAX DC CURRENT (A)	SIZE W \times L \times H (mm ³)	VENDOR
CDRH3D16	2.2	75	1.20	3.8 \times 3.8 \times 1.8	Sumida
CDH3B16	2.2	70	1.20	4.0 \times 4.0 \times 1.8	Ceaiya

OUTPUT AND INPUT CAPACITOR SELECTION

Low ESR (equivalent series resistance) capacitors should be used to minimize the output voltage ripple. Multilayer ceramic capacitors are an excellent choice as they have extremely low ESR and are available in small footprints. A 4.7 μ F to 20 μ F output capacitor is sufficient for most applications. Larger values up to 22 μ F may be used to obtain extremely low output voltage ripple and improve transient response. An additional phase lead capacitor may be required with output capacitors larger than 10 μ F to maintain acceptable phase margin. X5R and X7R dielectric materials are preferred for their ability to maintain capacitance over wide voltage and temperature ranges.

Low ESR input capacitors reduce input switching noise and reduce the peak current drawn from the battery. It follows that ceramic capacitors are also a good choice for input decoupling and should be located as close as possible to the device. A 10 μ F input capacitor is sufficient for virtually any application. Larger values may be used without limitations. Table 2 shows a list of several ceramic capacitor manufacturers. Consult the manufacturers directly for detailed information on their entire selection of ceramic capacitors.

Table 2. Capacitor Vendor Information

SUPPLIER	WEBSITE
AVX	www.avxcorp.com
Murata	www.murata.com
Taiyo Yuden	www.t-yuden.com

Packaging Information

SOT-23-6 Package Outline Dimension

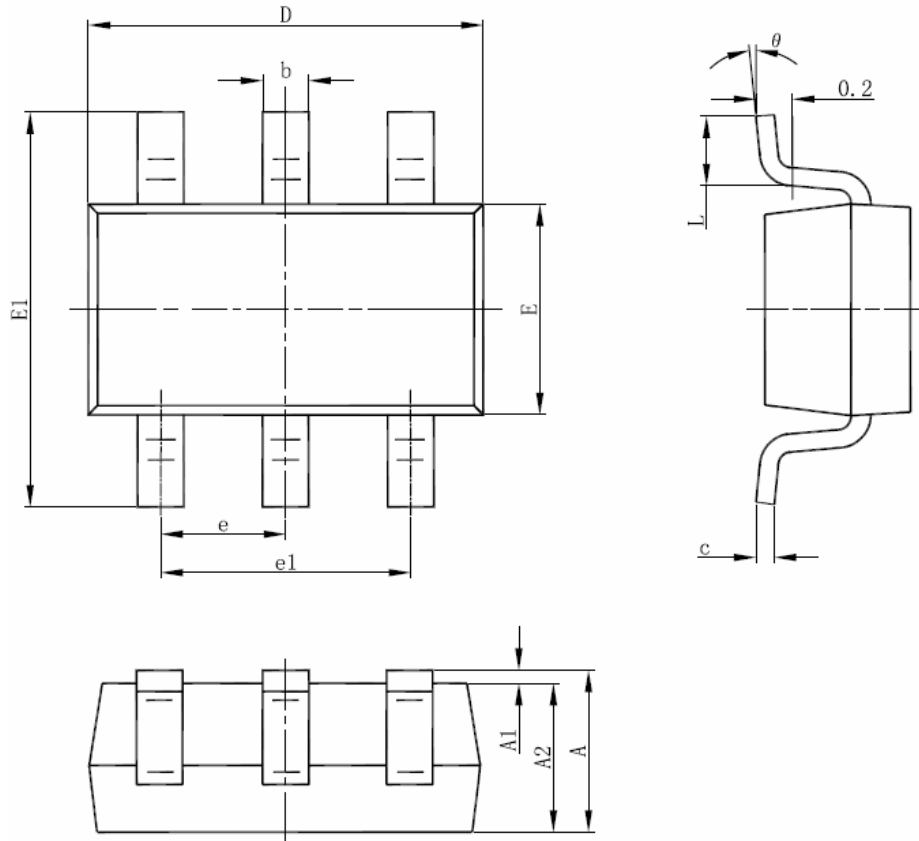

Symbol	Dimensions In Millimeters		Dimensions In Inches	
	Min	Max	Min	Max
A	1.050	1.250	0.041	0.049
A1	0.000	0.100	0.000	0.004
A2	1.050	1.150	0.041	0.045
b	0.300	0.500	0.012	0.020
c	0.100	0.200	0.004	0.008
D	2.820	3.020	0.111	0.119
E	1.500	1.700	0.059	0.067
E1	2.650	2.950	0.104	0.116
e	0.950(BSC)		0.037(BSC)	
e1	1.800	2.000	0.071	0.079
L	0.300	0.600	0.012	0.024
θ	0°	8°	0°	8°