

UL 153

0-7629-0518-2

Portable Electric Luminaires

Underwriters Laboratories Inc. (UL)
333 Pfingsten Road
Northbrook, IL 60062-2096

Portable Electric Luminaires, UL 153

Twelfth Edition, Dated March 25, 2002

The new and revised requirements were originally published as revisions to the Eleventh edition of this UL Standard. These requirements are now reissued for, and renumbered in accordance with, the Twelfth edition of this UL Standard.

The new and revised requirements are substantially in accordance with UL's Bulletin(s) on this subject dated December 17, 1999 and September 7, 2001. The bulletin(s) is now obsolete and may be discarded.

As indicated on the title page (page 1), this UL Standard for Safety is an American National Standard. Attention is directed to the note on the title page of this Standard outlining the procedures to be followed to retain the approved text of this ANSI/UL Standard.

The master for this Standard at UL's Northbrook Office is the official document insofar as it relates to a UL service and the compliance of a product with respect to the requirements for that product and service, or if there are questions regarding the accuracy of this Standard.

UL's Standards for Safety are copyrighted by UL. Neither a printed copy of a Standard, nor the distribution diskette for a Standard-on-Diskette and the file for the Standard on the distribution diskette should be altered in any way. All of UL's Standards and all copyrights, ownerships, and rights regarding those Standards shall remain the sole and exclusive property of UL.

All rights reserved. No part of this publication may be reproduced, stored in a retrieval system, or transmitted in any form by any means, electronic, mechanical photocopying, recording, or otherwise without prior permission of UL.

Revisions of UL Standards for Safety are issued from time to time. A UL Standard for Safety is current only if it incorporates the most recently adopted revisions.

UL provides this Standard "as is" without warranty of any kind, either expressed or implied, including but not limited to, the implied warranties of merchantability or fitness for any purpose.

In no event will UL be liable for any special, incidental, consequential, indirect or similar damages, including loss of profits, lost savings, loss of data, or any other damages arising out of the use of or the inability to use this Standard, even if UL or an authorized UL representative has been advised of the possibility of such damage. In no event shall UL's liability for any damage ever exceed the price paid for this Standard, regardless of the form of the claim.

UL will attempt to answer support requests concerning electronic versions of its Standards. However, this support service is offered on a reasonable efforts basis only, and UL may not be able to resolve every support request. UL supports the electronic versions of its Standards only if they are used under the conditions and operating systems for which it is intended. UL's support policies may change from time-to-time without notification.

UL reserves the right to change the format, presentation, file types and formats, delivery methods and formats, and the like of both its printed and electronic Standards without prior notice.

Purchasers of the electronic versions of UL's Standards for Safety agree to defend, indemnify, and hold UL harmless from and against any loss, expense, liability, damage, claim, or judgement (including reasonable attorney's fees) resulting from any error or deviation introduced while purchaser is storing an electronic Standard on the purchaser's computer system.

If a single-user version electronic Standard was purchased, one copy of this Standard may be stored on the hard disk of a single personal computer, or on a single LAN file-server or the permanent storage device of a multiple-user computer in such a manner that this Standard may only be accessed by one user at a time and for which there is no possibility of multiple concurrent access.

If a multiple-user version electronic Standard was purchased, one copy of the Standard may be stored on a single LAN file-server, or on the permanent storage device of a multiple-user computer, or on an Intranet server. The number of concurrent users shall not exceed the number of users authorized.

Electronic Standards are intended for on-line use, such as for viewing the requirements of a Standard, conducting a word search, and the like. Only one copy of the Standard may be printed from each single-user version of an electronic Standard. Only one copy of the Standard may be printed for each authorized user of a multiple-user version of an electronic Standard. Because of differences in the computer/software/printer setup used by UL and those of electronic Standards purchasers, the printed copy obtained by a purchaser may not look exactly like the on-line screen view or the printed Standard.

An employee of an organization purchasing a UL Standard can make a copy of the page or pages being viewed for their own fair and/or practical internal use.

The requirements in this Standard are now in effect, except for those paragraphs, sections, tables, figures, and/or other elements of the Standard having future effective dates as indicated in the note following the affected item. The prior text for requirements that have been revised and that have a future effective date are located after the Standard, and are preceded by a "SUPERSEDED REQUIREMENTS" notice.

New product submittals made prior to a specified future effective date will be judged under all of the requirements in this Standard including those requirements with a specified future effective date, unless the applicant specifically requests that the product be judged under the current requirements. However, if the applicant elects this option, it should be noted that compliance with all the requirements in this Standard will be required as a condition of continued Listing, Recognition, and Follow-Up Services after the effective date, and understanding of this should be signified in writing.

Copyright © 2002 Underwriters Laboratories Inc.

This Standard consists of pages dated as shown in the following checklist:

Page	Date
1-204	March 25, 2002
A1-A2	March 25, 2002

MARCH 25, 2002



1

UL 153

Standard for Portable Electric Luminaires

The first through the eleventh editions were titled Portable Electric Lamps.

First Edition – October, 1952
Second Edition – August, 1955
Third Edition – March, 1958
Fourth Edition – September, 1970
Fifth Edition – October, 1976
Sixth Edition – August, 1978
Seventh Edition – April, 1981
Eighth Edition – April, 1982
Ninth Edition – November, 1988
Tenth Edition – May, 1994
Eleventh Edition – May, 1995

Twelfth Edition

March 25, 2002

The most recent designation of ANSI/UL 153 as an American National Standard occurred on January 14, 2002.

This ANSI/UL Standard for Safety, which consists of the Twelfth edition is under continuous maintenance, whereby each revision is ANSI approved upon publication. Comments or proposals are to be sent to the UL-RTP Standards Department, 12 Laboratory Dr., Research Triangle Park, NC 27709-3995.

An effective date included as a note immediately following certain requirements is one established by Underwriters Laboratories Inc.

Revisions of this Standard will be made by issuing revised or additional pages bearing their date of issue. A UL Standard is current only if it incorporates the most recently adopted revisions, all of which are itemized on the transmittal notice that accompanies the latest set of revised requirements.

0-7629-0518-2

COPYRIGHT © 2002 UNDERWRITERS LABORATORIES INC.

No Text on This Page

CONTENTS

FOREWORD	16
-----------------------	----

INTRODUCTION

1 Scope	17
2 Glossary	18
3 Organization and Application	21
4 Components	22
5 Units of Measurement	22
6 Undated References	23

PART I**CONSTRUCTION****MECHANICAL CONSTRUCTION – GENERAL**

7 General	23
8 Assembly and Packaging	23
9 Enclosures	25
10 Metal Thickness for Enclosures	26
11 Corrosion Protection	27
12 Polymeric Enclosures	28
13 Polymeric Decorative Parts	28
14 Enclosure Openings	29
15 Wireways and Tubing	31
16 Shade Construction	31
17 Strain Relief	32
18 Portable Luminaires Having Play Value	33
19 Resistance to Liquid Damage	33
20 Portable Luminaire Containing Hazardous Substance	33

ELECTRICAL CONSTRUCTION – GENERAL

21 General	34
22 Assembly and Packaging	34
23 Accessibility of Live Parts	34
24 Electrical Spacings	36
25 Insulating Materials	38
26 Electrical Ratings	38
27 Wiring and Conductors	39
27.1 Conductor size	39
27.2 Temperature rating	40
28 Splices and Connections	43
29 Wiring Attached to Movable or Flexible Parts	43
30 Protection of Wiring	44
31 Power-Supply Cords	45
32 Attachment Plugs	46
33 Interconnected Units	48

34	Alternate Power-Supply Connections	48
35	Polarization and Identification	49
36	Grounding and Bonding	50
37	Electronic Circuits	51
38	Secondary Low Voltage Circuits	51
39	Separation of Secondary Circuit Conductors	52
40	Component Mounting	52
41	Lampholders	53
41.1	General	53
41.2	Incandescent lampholders	54
42	Switches and Dimmers	55
43	Receptacles	57
44	Transformers	57
45	Motors	58

INCANDESCENT UNITS – SUPPLEMENTARY

46	General	58
47	Temperature Test-Exempt Units	58
47.1	General	58
47.2	Determination of temperature test-exempt status	59
47.3	Shade designation	59
47.4	Lamp-to-shade spacing	61
47.5	Wire insulation temperature rating	65
47.6	Other shade designs	66
48	Tests	66
48.1	Normal temperature test	66
49	Markings	66
50	Instructions	66

TUNGSTEN HALOGEN UNITS – SUPPLEMENTARY

51	General	66
52	Construction – Mechanical	67
52.1	General	67
52.2	Guard	68
52.3	Guards for torchiere style units	70
52.4	Lamp containment barrier	72
52.5	Ultraviolet (UV) filter	73
52.6	Flexible or articulated arms	74
53	Construction – Electrical	75
53.1	Switches	75
53.2	Interlock switch	75
53.3	Automatic temperature-regulating or limiting control	76
53.4	Tipover switch	76
54	Tests	76
54.1	Normal temperature test	76
54.2	Tungsten-halogen lamp adjacent surfaces and overlamping abnormal operation tests	77
54.3	Tungsten-halogen torchiere abnormal operation tests	77
54.4	Guard, lamp containment barrier & UV filter security tests	77
54.5	Polymeric lamp containment test	77
54.6	Interlock switch tests	77
55	Marking	78

56 Instructions	78
-----------------------	----

FLUORESCENT UNITS – SUPPLEMENTARY

57 General	78
58 Construction – Electrical	78
58.1 Ballasts	78
58.2 Lampholder	78
58.3 Wire temperature ratings	79
58.4 Power-supply cord	79
58.5 Grounding	79
59 Tests	79
59.1 Normal temperature test	79
59.2 Abnormal operation shorted starter test	80
60 Temperature Test-Exempt Units	80
61 Marking	81

HIGH INTENSITY DISCHARGE UNITS – SUPPLEMENTARY

62 General	81
63 Construction – Mechanical	81
63.1 Metal halide lamp containment and UV filter	81
64 Construction – Electrical	82
64.1 Lampholders	82
64.2 Ballasts	82
64.3 Capacitors	82
64.4 Nonintegral oil-filled capacitors	83
65 Tests	84
65.1 Normal temperature test	84
65.2 Glass impact test	85
65.3 Glass thermal shock/containment test	85
66 Markings	85

SURFACE MOUNTED UNITS FOR WALL, UNDER-CABINET OR APPLIANCE MOUNTING – SUPPLEMENTARY

67 General	85
68 Wall Mounted Units	86
68.1 General	86
68.2 Construction – mechanical	86
68.3 Construction – electrical	87
68.4 Tests	87
68.5 Instructions	87
69 Under-Shelf Mounted Units	87
69.1 General	87
69.2 Mounting means	87
69.3 Construction – electrical	88
69.4 Tests	89
69.5 Markings	89
70 Appliance Mounted Units	89
70.1 General	89
70.2 Instructions	89

CORD AND CHAIN SUSPENDED UNITS – SUPPLEMENTARY

71	General	89
72	Construction – Mechanical	90
	72.1 Chains	90
	72.2 Support hardware	90
	72.3 Maximum weight	91
73	Construction – Electrical	92
	73.1 Internal wiring protection	92
	73.2 Power-supply cord	92
	73.3 Lampholders and switches	93
74	Tests	94
	74.1 Mounting means test	94
	74.2 Tests for suspended toys	94
75	Markings	94
76	Instructions	94

CLAMP-ON MOUNTED UNITS – SUPPLEMENTARY

77	General	94
78	Construction – Mechanical	94
	78.1 Clamp	94
79	Construction – Electrical	95
	79.1 Power-supply cords	95
	79.2 Lampholders and switches	95
80	Tests	96
	80.1 Mounting means test	96

PORTABLE CABINET LIGHTS – SUPPLEMENTARY

81	General	96
82	Construction – Mechanical	96
	82.1 Mounting flange	96
83	Construction – Electrical	97
	83.1 Power-supply cords	97
	83.2 Interconnecting cord	97
	83.3 Attachment plugs and receptacles	97
	83.4 Lampholders	98
	83.5 Low voltage portable cabinet lights	98
84	Tests	98
	84.1 Normal temperature test	98
85	Markings	98
86	Instructions	99

UNITS FOR USE WITH OFFICE FURNISHINGS – SUPPLEMENTARY

87	General	99
88	Construction – Mechanical	99
89	Construction – Electrical	99
	89.1 Power-supply cords	99
	89.2 Plugs and receptacles	100
	89.3 Interconnecting cord	100
	89.4 Overcurrent protection	100

90	Markings	100
91	Instructions	100

CONVERTIBLE UNITS – SUPPLEMENTARY

92	General	101
93	Construction – Mechanical	101
93.1	Swag-to-chandelier conversion kits	101
93.2	Surface mount conversion kits	101
94	Construction – Electrical	101
94.1	Grounding	101
94.2	Polarity	102
95	Markings	102
96	Instructions	102

INTERCHANGEABLE UNITS – SUPPLEMENTARY REQUIREMENTS

97	General	102
98	Construction – Mechanical	102
98.1	Mounting	102
99	Construction – Electrical	103
99.1	Power-supply cords	103
99.2	Polarization	103
99.3	Adapter	103
100	Markings	103

TRACK-STYLE UNITS – SUPPLEMENTARY

101	General	103
102	Construction – Mechanical	104
102.1	Track	104
102.2	Securement of cord and end cap	104
102.3	Mounting means	104
103	Construction – Electrical	105
103.1	Power-supply cords	105
103.2	Polarity	105
103.3	Receptacles	105
104	Tests	105
104.1	Mechanical means of polarity test	105
104.2	Track clip securement test	105
105	Markings	106
106	Instructions	106

PORTABLE LUMINAIRE SUBASSEMBLIES – SUPPLEMENTARY

107	General	106
108	Construction – Mechanical	106
108.1	General	106
108.2	Shade	106
109	Construction – Electrical	106
109.1	General	106
109.2	Power-supply cord	107
109.3	Mounting of components	107

110	Tests	107
110.1	Assembly and installation test	107
111	Markings	107
112	Instructions	107

WORK LIGHTS – SUPPLEMENTARY

113	General	108
114	Construction – Mechanical	108
114.1	Assembly	108
114.2	Guards	108
114.3	Handles	110
114.4	Bases and stands	110
115	Construction – Electrical	111
115.1	Power-supply cords	111
115.2	Grounding type attachment plug	111
115.3	Receptacles	111
115.4	Tipover switches	112
115.5	Integral power supplies	112
116	Tests	112
116.1	Normal temperature test	112
116.2	Tungsten-halogen unit tests	112
116.3	Stability tests	113
117	Markings	113

WET LOCATION USE – SUPPLEMENTARY

118	General	113
119	Construction – Mechanical	113
119.1	Enclosure	113
119.2	Water shields	114
119.3	Corrosion protection	114
119.4	Drain openings	115
119.5	Gaskets	115
119.6	Mounting stakes	116
120	Construction – Electrical	116
120.1	Power-supply cords	116
120.2	Grounding type attachment plug	116
120.3	Receptacles	116
120.4	Lampholders	117
120.5	Switches	117
120.6	Electrical insulation	117
121	Tests	117
121.1	Wet location tests	117
122	Markings	117
123	Instructions	117

PART II**PERFORMANCE****GENERAL – NORMAL TEMPERATURE TEST**

124	General	117
125	Test Method – General	118
125.1	Temperature limits	118
125.2	Test duration	120
125.3	Temperature measurement by thermocouple	121
125.4	Temperature measurement by change-of-resistance	121
125.5	Ambient temperature measurement	122
125.6	Test voltage, current, and wattage	123
125.7	High intensity discharge lamp nominal test conditions	123
125.8	Incandescent test lamps	124
125.9	Tungsten-halogen test lamps	125
125.10	Fluorescent test lamps	125
125.11	High intensity discharge test lamps	125
125.12	Shade positions and decorative parts	126
126	Specific Test Conditions – Free Standing and Surface Mounted Units	126
126.1	General	126
126.2	Test results	127
127	Specific Test Conditions – Portable Cabinet Lights	127
127.1	Other than pot style	127
127.2	Pot style	129
127.3	Test results	131
128	Specific Test Conditions – Work Lights	131
128.1	General	131
128.2	Test results	131

GENERAL – ABNORMAL OPERATION TESTS

129	Adjustable Position or Multiple Shade Abnormal Operation Test	132
129.1	General	132
129.2	Test method – general	132
129.3	Test method – adjustable or flexible shade position	133
129.4	Test method – multiple shades	133
129.5	Test method – folding position	133
129.6	Test results	133
130	Transformer Short-Circuited Test	134
130.1	General	134
130.2	Test method	134
130.3	Test results	134
131	Component Fault Test	135
131.1	General	135
131.2	Test method	135
131.3	Test results	136

GENERAL – MECHANICAL TESTS

132	Stability Test	136
132.1	General	136
132.2	Test method – general	136
132.3	Test method – units with flexible or articulated arm	137
132.4	Test method – units having provisions for loading	137
132.5	Test results	138
133	Strain Relief Test	138
133.1	General	138
133.2	Test method	138
133.3	Test results	138
134	Drop Test	139
134.1	General	139
134.2	Test method	139
134.3	Test results	139
135	Security of Screws Test	139
135.1	General	139
135.2	Test method	140
135.3	Test results	140

GENERAL – ELECTRICAL TESTS

136	Grounding Continuity Test	140
136.1	General	140
136.2	Test method	140
136.3	Test results	140
137	Dielectric Voltage-Withstand Test	141
137.1	General	141
137.2	Test method	141
137.3	Test results	141
138	Transformer Voltage Output Test	141
138.1	General	141
138.2	Test method	142
138.3	Test results	142
139	Low Voltage Hinged or Movable Part Cycling Test	142
139.1	General	142
139.2	Test method	142
139.3	Test results	142
140	Resistance to Moisture Test	143
140.1	General	143
140.2	Test method	143
140.3	Test results	145

INCANDESCENT UNIT TESTS

141	Lamp Harp Torque Test	145
141.1	General	145
141.2	Test method	145
141.3	Test results	146
142	Lampshade Ease of Ignition Test	146
142.1	General	146
142.2	Test method	146

142.3 Test results	147
--------------------------	-----

TUNGSTEN-HALOGEN UNIT TESTS

143 Tungsten Halogen Lamp Adjacent Surfaces and Overlapping Abnormal Operation Tests .	147
143.1 General	147
143.2 Test method – general	148
143.3 Test method – severe condition	148
143.4 Test method – vertical surface	148
143.5 Test method – supporting surface	149
143.6 Test method – overhead surface	149
143.7 Test method – overlapping	149
143.8 Test results	149
144 Tungsten-Halogen Lamp Guard, Lamp Containment Barrier, and UV Filter Security Test ..	150
144.1 General	150
144.2 Test method	150
144.3 Test results	150
145 Tungsten-Halogen Torchiere Abnormal Operation Test	151
145.1 General	151
145.2 Test method	151
145.3 Test results	152
146 Tungsten-Halogen Torchiere Vertical Wall Test	152
146.1 General	152
146.2 Test Method	153
146.3 Test Results	153
147 Tungsten-Halogen Torchiere Stability Test	153
147.1 General	153
147.2 Test Method	154
147.3 Test Results	154
148 Tungsten-Halogen Torchiere Flexible or Articulated Arm Stop Test	154
148.1 General	154
148.2 Test Method	154
148.3 Test Results	154
149 <i>Reserved for future use</i>	154
150 Polymeric Lamp Containment Barrier Test	154
150.1 General	154
150.2 Test method	155
150.3 Test results	155
151 Interlock Switch Endurance Test	156
151.1 General	156
151.2 Test method	156
151.3 Test results	156
152 Heat Flux Density Measurement Test	156
152.1 General	156
152.2 Test method	156
152.3 Test results	157

FLUORESCENT UNIT TESTS

153 Abnormal Operation – Shorted Starter Test	158
153.1 General	158
153.2 Test method	158
153.3 Test results	158

HIGH-INTENSITY-DISCHARGE UNIT TESTS

154	Glass Impact Test	159
154.1	General	159
154.2	Test method	159
154.3	Test results	159
155	Glass Thermal Shock/Containment Test	159
155.1	General	159
155.2	Test method	159
155.3	Test results	160

SURFACE MOUNTED UNIT FOR WALL OR UNDERSHELF MOUNTING TESTS

156	Mounting Means Test – Surface Mounted Unit	160
156.1	General	160
156.2	Test method	160
156.3	Test results	160

CORD AND CHAIN SUSPENDED UNIT TESTS

157	Mounting Means Test – Chain and Suspended Units	161
157.1	General	161
157.2	Test method – general	161
157.3	Test method – swag unit	161
157.4	Test method – hanging unit	161
157.5	Test results	162
158	Test for Suspended Toys	162
158.1	General	162
158.2	Test method	162
158.3	Test results	163

CLAMP-ON UNIT TESTS

159	Mounting Means Test – Clamp-On Unit	163
159.1	General	163
159.2	Test method	163
159.3	Test results	164

TRACK-STYLE UNIT TESTS

160	Mechanical Means of Polarity Test	164
160.1	General	164
160.2	Test method	165
160.3	Test results	165
161	Track Clip Securement Test	165
161.1	General	165
161.2	Test method	165
161.3	Test results	166

PORTABLE LUMINAIRE SUBASSEMBLY TEST

162	Assembly and Installation Test	166
162.1	General	166
162.2	Test method	166
162.3	Test results	166

WORK LIGHT TESTS

163	Guard Securement Test	167
163.1	General	167
163.2	Test method	167

WET LOCATION USE TESTS

164	Rain and Sprinkler Tests	167
164.1	General	167
164.2	Test method – general	168
164.3	Test method – rain test	168
164.4	Test method – sprinkler test	171
164.5	Test results	173
165	Polymeric Thermal Conditioning Test	173
165.1	General	173
165.2	Test method	173
165.3	Test results	174
166	Gasket Accelerated Aging Test	174
166.1	General	174
166.2	Test method A	174
166.3	Test results A	174
166.4	Test method B	174
166.5	Test results B	175
167	Gasket Adhesion Test	175
167.1	General	175
167.2	Test method A	175
167.3	Test results A	175
167.4	Test method B	175
167.5	Test results B	176
168	Paint Adhesion Test	176
168.1	General	176
168.2	Test method	176
168.3	Test results	176

PART III**MARKINGS**

169	General	176
169.1	Form	176
169.2	Form "A" marking label	177
169.3	Tag type markings	178
169.4	Pictograph type markings	178
169.5	Manufacturer's identification	179

169.6	Electrical ratings	179
169.7	Mounting orientation	179
169.8	Hot surface marking	179
169.9	Interconnected units	180
169.10	Units with integral shelf, rack, or table	180
169.11	Resemblance to toy	180
169.12	Marking for luminaires containing hazardous substances	181
170	Incandescent Units	181
170.1	Lamp replacement	181
170.2	Incandescent units shipped without lampshade	182
170.3	Removal of dust cover	183
171	Tungsten Halogen Units	183
171.1	Lamp replacement – single envelope lamp	183
171.2	Lamp replacement – double envelope lamp	183
171.3	Risk of fire and injury warnings	184
171.4	Five foot minimum mounting	185
171.5	Date code	185
172	Fluorescent Units	185
172.1	Lamp replacement	185
173	High-Intensity-Discharge Units	186
173.1	Lamp replacement	186
173.2	Double-ended metal halide lamp	187
174	Cord and Chain Suspended Units	187
175	Portable Cabinet Lights	187
175.1	Identification	187
175.2	Remote transformer	187
175.3	Shortened cord	188
175.4	Interconnecting receptacle	188
176	Units for Use with Office Furnishings	188
177	Convertible Units	188
178	Interchangeable Units	189
179	Track-Style Units	189
180	Portable Luminaire Subassemblies	190
181	Work Light	190
182	Wet Location Use	191

PART IV

INSTRUCTIONS

183	General	191
183.1	Location	191
183.2	Assembly instructions	191
183.3	Polarization instructions	191
183.4	Interconnected units	192
183.5	Pin type attachment plug	192
183.6	Shortened cord	192
183.7	Alternate supply connection	192
183.8	Attachment plugs complying with foreign standards	193
184	Incandescent Units	193
184.1	Units shipped without lampshade	193
185	Tungsten-Halogen Units	193

186	Surface Mounted Units	194
186.1	General	194
186.2	Appliance mounting	194
187	Cord and Chain Suspended Units	194
188	Portable Cabinet Lights	195
188.1	Installation instructions	195
188.2	Markings	197
189	Units for Use with Office Furnishings	197
190	Convertible Units	197
190.1	General	197
190.2	Swag to chandelier installation	197
190.3	Surface mount installation	198
191	Track-Style Units	198
192	Portable Luminaire Subassemblies	199
193	Wet Location Use	199

PART V

MANUFACTURING AND PRODUCTION TESTS

194	Manufacturing and Production Tests	200
194.1	General	200
194.2	Test method	200
194.3	Test results	202
195	Polarity Test	202
195.1	General	202
195.2	Test method	202
195.3	Test results	203
196	Continuity of Grounding Connection Test	203
196.1	General	203
196.2	Test method	203
196.3	Test results	203

APPENDIX A

Standards for Components.....	A1
-------------------------------	----

FOREWORD

A. This Standard contains basic requirements for products covered by Underwriters Laboratories Inc. (UL) under its Follow-Up Service for this category within the limitations given below and in the Scope section of this Standard. These requirements are based upon sound engineering principles, research, records of tests and field experience, and an appreciation of the problems of manufacture, installation, and use derived from consultation with and information obtained from manufacturers, users, inspection authorities, and others having specialized experience. They are subject to revision as further experience and investigation may show is necessary or desirable.

B. The observance of the requirements of this Standard by a manufacturer is one of the conditions of the continued coverage of the manufacturer's product.

C. A product which complies with the text of this Standard will not necessarily be judged to comply with the Standard if, when examined and tested, it is found to have other features which impair the level of safety contemplated by these requirements.

D. A product that contains features, characteristics, components, materials, or systems new or different from those covered by the requirements in this standard, and that involves a risk of fire or of electric shock or injury to persons shall be evaluated using appropriate additional component and end-product requirements to maintain the level of safety as originally anticipated by the intent of this standard. A product whose features, characteristics, components, materials, or systems conflict with specific requirements or provisions of this standard does not comply with this standard. Revision of requirements shall be proposed and adopted in conformance with the methods employed for development, revision, and implementation of this standard.

E. UL, in performing its functions in accordance with its objectives, does not assume or undertake to discharge any responsibility of the manufacturer or any other party. The opinions and findings of UL represent its professional judgment given with due consideration to the necessary limitations of practical operation and state of the art at the time the Standard is processed. UL shall not be responsible to anyone for the use of or reliance upon this Standard by anyone. UL shall not incur any obligation or liability for damages, including consequential damages, arising out of or in connection with the use, interpretation of, or reliance upon this Standard.

F. Many tests required by the Standards of UL are inherently hazardous and adequate safeguards for personnel and property shall be employed in conducting such tests.

INTRODUCTION

1 Scope

1.1 These requirements cover portable luminaires (portable electric lamps) and subassemblies whose primary function is task or ambient illumination. These products are provided with a flexible cord and an attachment plug for connection to a nominal 120-volt, 15- or 20-ampere branch circuit, and intended for use in accordance with the National Electrical Code, ANSI/NFPA 70.

1.2 These requirements also cover dedicated portable luminaires that employ a connector other than an attachment plug that is intended to connect to a compatible connector assembly that is for connection to a nominal 120-volt, 15- or 20-ampere branch circuit, and intended for use in accordance with the National Electrical Code, ANSI/NFPA 70.

1.3 These requirements also cover portable luminaires that are intended for use on standard power systems other than a nominal 120-volt, 15- or 20-amperes.

1.4 These requirements do not cover Christmas tree and decorative lighting outfits, or electric candles and candelabras without lamp shades, which are covered by the Standard for Christmas Tree and Decorative Outfits, UL 588.

1.5 These requirements do not cover direct plug-in nightlights, sun and heat lamps, aquarium lamps, medical and dental lights, portable electric hand lamps, signs and commercial advertising displays, photographic lamps, or portable luminaires for marine use or for use in hazardous locations as defined in the National Electrical Code, ANSI/NFPA 70.

1.6 A product that contains features, characteristics, components, materials, or systems new or different from those covered by the requirements in this standard, and that involves a risk of fire or of electric shock or injury to persons shall be evaluated using appropriate additional component and end-product requirements to maintain the level of safety as originally anticipated by the intent of this standard. A product whose features, characteristics, components, materials, or systems conflict with specific requirements or provisions of this standard does not comply with this standard. Revision of requirements shall be proposed and adopted in conformance with the methods employed for development, revision, and implementation of this standard.

2 Glossary

2.1 For the purpose of these requirements the following definitions apply.

2.2 ADAPTER – A component of a lighting assembly intended to mate with a base and provide mechanical attachment and electrical connection for interchangeable lighting assemblies.

2.3 ADAPTER FOR TRACK STYLE UNIT – A component of a lighting assembly intended to mate with a track and provide mechanical securement and electrical connection for track-style type units.

2.4 BALLAST – A current limiting device required to start and operate fluorescent lamps.

2.5 BASE – A weighted free standing or wall-mounted, cord-connected support that provides the electrical supply to one or more replaceable or interchangeable lighting assemblies.

2.6 BULB (LAMP) – See 2.20.

2.7 CLASS 2 CIRCUIT – An isolated secondary circuit involving a potential of not more than 42.4 volts peak open circuit supplied by:

- a) An inherently-limited Class 2 transformer;
- b) A combination of an isolated transformer secondary winding and a fixed impedance or regulating network that together comply with the performance requirements for an inherently-limited Class 2 transformer; or
- c) One or more combinations of a transformer and an overcurrent protective device that together comply with the performance requirements for a noninherently-limited Class 2 transformer.

However, a circuit derived from a line-connected circuit by connecting impedance in series with the supply circuit as a means of limiting the voltage and current is not determined to be a Class 2 circuit.

2.8 CLEARANCE DISTANCE – The shortest distance measured through air between conductive parts.

2.9 COMBUSTION – Burning; or a chemical process (as an oxidation) accompanied by the evolution of light and heat. Examples of combustion are any blackening or disintegration, glowing, flaming or charring of any material or test indicators such as tissue paper, cheesecloth or wood.

2.10 COMPACT FLUORESCENT LAMP – A fluorescent lamp that is formed such that both ends fit into a support that is inserted into a single lampholder.

2.11 CONVERTIBLE UNIT – A portable luminaire provided with instructions and a kit that converts the portable luminaire to a fixed luminaire (lighting fixture).

2.12 DECORATIVE PART – A part whose total or partial destruction does not affect intended performance of the portable luminaire.

2.13 END CAP – A cover intended to close the open end of a track.

2.14 EXPOSED PART – A part that is not enclosed to prevent contact.

2.15 FRICTION MATERIAL – Rubber or elastomer with or without dimples or ridges. Plastic or metal with or without dimples or ridges is not determined to be a friction material.

2.16 GUARD – That portion of the portable luminaire that prevents inadvertent contact with the lamp. Is able to be integral with the shield.

2.17 HOUSED PART – A part that is prevented from being contacted by a housing that does not meet the requirements for enclosing live parts.

2.18 INTERLOCK SWITCH – A switch that de-energizes the lamps when the portable luminaire is opened or when the lamp is replaced.

2.19 ISOLATED SECONDARY CIRCUIT – A circuit derived from an isolated secondary winding of a transformer and that has no direct connection back to the line-connected circuit (other than through grounding means). A secondary circuit that has a direct connection back to the line-connected circuit is determined to be part of the line-connected circuit.

2.20 LAMP – The device, commonly called a “light bulb” or “bulb” intended to be inserted into a lampholder (“socket”) to produce light.

2.21 LAMP CONTAINMENT BARRIER – Any part of a portable luminaire that encloses the lamp.

2.22 LIGHTING ASSEMBLY, INTERCHANGEABLE – An assembly consisting of a lighting unit and an adapter. One or more lighting assemblies is used with a base to make up the portable luminaire for interchangeable lighting assemblies.

2.23 LIGHTING ASSEMBLY, TRACK-STYLE – An assembly consisting of a lighting unit and an adapter. One or more lighting assemblies is used with a track to make up the track-style type unit.

2.24 LIGHTING UNIT, INTERCHANGEABLE – An assembly that includes a lamp enclosure or lamp compartment and any components and parts required for connecting the lamp compartment or enclosure to the adapter for interchangeable lighting assemblies.

2.25 LIGHTING UNIT, TRACK-STYLE – An assembly that includes a lamp enclosure or lamp compartment and any components and parts required for connecting the lamp compartment to the adapter for the track-style type units.

2.26 LINE OF SIGHT – A straight, unbroken, unobstructed, direct line between the eye and an object (for example, the lamp).

2.27 LIVE PART – A metal or other conductive part that has a potential difference during operation with respect to ground or any other conductive part.

2.28 LOW-VOLTAGE CIRCUIT – A circuit involving a potential of not more than 30 volts alternating current (42.4 peak) open circuit.

2.29 NORMAL MAINTENANCE AND USE – The cleaning, adjusting, moving, maintaining, and using of the portable luminaire. Includes items such as:

- a) Replacing a lamp, starter or fuse;
- b) Adjusting an illumination level; and

c) Removal or cleaning of all parts not secured by use of tools.

2.30 ORDINARY TOOL – A tool, such as a flat-blade or cross-head screwdriver, a nut driver, or pliers.

2.31 POLYMERIC MATERIAL – A material made of a chemical compound or mixture of compounds formed by polymerization and consisting of repeating structural units. Polymeric materials include thermoplastic, thermosetting, and elastomeric materials. A thermoplastic material is able to be easily softened and resoftened by repeated heating. A thermosetting material cures by chemical reaction when heated and, when cured, is unable to be resoftened by reheating. An elastomeric material is capable of being stretched at room temperature to at least twice its length under low stress and recovers to its original length when released from the stress.

2.32 PORTABLE CABINET LIGHT – A portable lamp intended for final installation into a cabinet (open or enclosed) such as a china hutch, bookcase, bar, console, bed headboard, or similar furniture.

2.33 PORTABLE LUMINAIRE – A portable luminaire, also commonly known as a portable lamp, as defined in the scope of the Standard. For purposes of requirements in the Standard, the term "portable luminaire", "luminaire", and "unit" are used interchangeably.

2.34 POWER-SUPPLY CORD FITTER – That portion of the assembly that terminates the power-supply cord at the track, connecting the conductors to the bus bars in the track.

2.35 REACTANCE BALLAST – A ballast, the impedance of which is provided by:

- a) Inductive reactance;
- b) Capacitive reactance; or
- c) Both inductance and capacitive reactance.

2.36 REACTOR (SIMPLE REACTANCE) BALLAST – A reactance type ballast in which the impedance (inductive reactance) is provided by a single coil and core - not a transformer. A reactor ballast usually has one lead in and one lead out.

2.37 SECONDARY CIRCUIT – A circuit that is supplied by an induced voltage from a primary where a primary circuit is that supplied by a branch circuit.

2.38 SHADE – The portion of the portable luminaire within which the lamp is located. The light from the lamp is diffused, deflected, reflected, transmitted through, or absorbed by the shade. The shade may be a functional or supportive part, or a decorative part.

2.39 SIGN – A self-contained, cord or permanently-connected, electrically illuminated product, usually with advertising or other words or symbols, intended to convey information or attract attention in a commercial setting.

2.40 SODALIME GLASS – Window glass which typically has a greenish tint readily discernible by viewing the glass from the edge. It scratches easily as compared to other types of glass. Sodalime glass is not determined to be heat resistant unless it is tempered.

2.41 SUBASSEMBLY – Consists of all the parts to a portable luminaire in an easy to assemble form either for "building" a unit (such as a craft kit) or rewiring a portable luminaire. They are intended to be assembled by a person presumed to possess little or no knowledge or no knowledge of electrical circuitry.

2.42 TEMPORARY – Used only for the amount of time required to complete the job. Not intended for long term use in one location. When the job is complete, the work light is moved to the next work area or stored until the next job.

2.43 TRACK – An enclosure that houses the bus bars and that houses or is integral with the bus bar support. Track is usually made of extruded material that usually resembles an "H" in cross section, with two vertical members connected by a horizontal member. The bus bar support and bus bars are factory-mounted in the lower half of the "H" and the connection of lighting assemblies is accomplished through the open bottom.

2.44 TUNGSTEN-HALOGEN DOUBLE ENVELOPE LAMP – See 2.45. The lamp also includes an outer integral glass envelope.

2.45 TUNGSTEN-HALOGEN SINGLE ENVELOPE LAMP – An incandescent lamp with a quartz or glass envelope, filled with a halogen gas, and a tungsten filament.

2.46 ULTRAVIOLET (UV) FILTER – A portion of the portable luminaire that limits ultraviolet (UV) emissions.

2.47 USER SERVICING – See 2.29.

2.48 VISIBLE PART – A part that is able to be partially enclosed and that is accessible.

2.49 WORK LIGHT – A cord and plug connected light for illumination of work areas such as construction sites, loading docks, and machinery work stations. Work lights are not intended to be hand held during use. Work lights are not intended for use in hazardous locations as defined in the National Electric Code, ANSI/NFPA 70.

3 Organization and Application

3.1 The requirements are divided into parts according to the following:

Part I consists of construction requirements:

Sections 7 – 45 – applicable to all portable luminaires; and

Sections 46 – 123 – applicable to specific type units.

Part II consists of performance tests:

Sections 124 – 140 – applicable to all portable luminaires; and

Sections 141 – 168 – applicable to specific type units.

Part III consists of marking requirements:

Section 169 – applicable to all portable luminaires; and

Sections 170 – 182 – applicable to specific type units.

Part IV consists of instruction requirements:

Section 183 – applicable to all portable luminaires; and

Sections 184 – 193 – applicable to specific type units.

Part V consists of manufacturing and production tests:

Sections 194 – 196 – applicable to all portable luminaires.

3.2 A portable luminaire is capable of having multiple supplementary requirements that are applicable. For example, a work light, in addition to complying with the general and the work light sections of the standard, shall also be required to comply with the supplementary requirements for tungsten-halogen and wet location type units when these requirements are applicable. Specific unit features which limit the application of the requirement(s) are identified by headings, subheadings, or the text of the paragraph. When a product type reference is not specified, the requirement is applicable to all portable luminaires.

4 Components

4.1 Except as indicated in 4.2, a component of a product covered by this standard shall comply with the requirements for that component. See Appendix A for a list of standards covering components generally used in the products covered by this standard.

4.2 A component is not required to comply with a specific requirement that:

- a) Involves a feature or characteristic not required in the application of the component in the product covered by this standard, or
- b) Is superseded by a requirement in this standard.

4.3 A component shall be used in accordance with its rating established for the intended conditions of use.

4.4 Specific components are incomplete in construction features or restricted in performance capabilities. Such components are intended for use only under limited conditions, such as certain temperatures not exceeding specified limits, and shall be used only under those specific conditions.

5 Units of Measurement

5.1 Values stated without parentheses are the requirement. Values in parentheses are explanatory or approximate information.

5.2 Unless indicated otherwise, all voltage and current values specified in this standard are rms.

6 Undated References

6.1 Any undated reference to a code or standard appearing in the requirements of this standard shall be interpreted as referring to the latest edition of that code or standard.

PART I

CONSTRUCTION

MECHANICAL CONSTRUCTION – GENERAL

7 General

7.1 These requirements apply to all portable luminaires and shall be used in conjunction with the applicable supplementary requirements in this standard.

8 Assembly and Packaging

8.1 Any portion of a portable luminaire that is detachable, for shipping purposes or otherwise, shall be constructed such that it is only able to be assembled in the intended manner.

Exception: A part that is capable of being detached and assembled without compromising the mechanical or electrical integrity of the unit is capable of being assembled in more than one manner.

8.2 A portable luminaire shall be shipped from the factory in a carton or as an unpackaged complete assembly. Unassembled parts, such as glassware, chains, and similar components, when required elsewhere in the standard to accompany the product, shall be included. Decorative glassware is not required to be mounted in a frame or holder and is able to be separately wrapped to protect it from breakage during shipment.

8.3 A portable luminaire is not required to be completely mechanically assembled when:

- a) All parts required to assemble the product, other than an ordinary tool, are provided with the unit;
- b) Splices or electrical connections are not exposed nor require completion in the assembly;
- c) The integrity of the strain relief at all wiring terminations is intact (see Strain Relief Test, Section 133);
- d) Assembly instructions are provided in accordance with 183.2; and
- e) When assembled in accordance with the manufacturer's instructions, the unit complies with the requirements in this standard.

Exception No. 1: A splice or connection is capable of being exposed or incomplete when it consists of interlocking plug/receptacle parts where the means of maintaining polarity and strain relief are inherent to the construction of the interlocking parts.

Exception No. 2: An insulation-piercing or crimp connector is capable of being exposed during the assembly operation when:

- a) All live parts of the connector and the conductors are insulated; and

b) The splice is located such that it and the conductors connected to it are unable to inadvertently snagged or grabbed.

8.4 When wires pass through a joint between sections of a portable luminaire that are separable for packing purposes, the joint shall be such that rotation of one section with respect to the other during the assembly of the sections is limited to not more than 360 degrees. Friction alone does not meet the intent of the requirement to prevent rotation.

Exception: When all of the following conditions exist, rotation between sections of a portable luminaire is not limited to 360 degrees:

a) The internal diameter of the tubing through which the wires pass is 1/2 inch (12.7 mm) or more;

b) The rotation during assembly is limited to not more than one revolution for each 3 inches (76 mm) of unobstructed tubing length through which the wires pass, when such rotation does not place any stress on the conductors; and

c) The conductors do not involve splices unless the splices are:

1) Inaccessible during assembly in accordance with Accessibility of Live Parts, Section 23; and

2) Secured and provided with strain relief that has been shown to be reliable and not easily defeated by the user.

8.5 When a splice or an electrical connection is located in a section of a portable luminaire that is separable for packing purposes, as noted in 8.3 and 8.4, the unit shall be provided with strain relief to reduce the risk of stress being transmitted to the splice or electrical connection during unpackaging and assembly of the luminaire. The strain relief shall be reliable and not easily defeated by the user. See the Strain Relief Test, Section 133.

8.6 When in any position of adjustment, a spring-loaded or adjustable section of a pole unit shall not transmit stress to a splice or wiring within any section of the unit either during assembly or when completely assembled. For example, the stem of an adjustable height floor unit shall raise and lower without binding or crimping the wiring of the unit.

9 Enclosures

9.1 A portable luminaire shall be constructed so that it has the mechanical strength required to resist the abuses to which it is subjected, without resulting in a risk of fire, electric shock, or injury to persons due to total or partial collapse of any part with resulting reduction of spacings (electrical or thermal), loosening or displacement of parts, or other serious defects.

9.2 A portable luminaire shall be constructed so that all user servicing is completed without subjecting any wiring, component, or part to mechanical damage, or reducing electrical spacings.

9.3 A portable luminaire shall be constructed of material such as glass, metal, urea, porcelain, phenolic composition, plastic or wood.

Exception: A decorative part, the failure of which does not interfere with the performance of the unit, is able to be constructed of any material.

9.4 A decorative part is able to be constructed of any material.

9.5 A part such as a splice, a tap, a wire, a transformer, a capacitor, a ballast, a current-carrying part, or a device with an exposed live part shall be contained in an enclosure constructed of metal, glass, ceramic, porcelain, or polymeric material during normal maintenance and use.

Exception No. 1: A current-carrying part of a wiring device (such as the screw shell and center contact of a lampholder, and the lampholder contacts, started holder contacts, and similar components of a fluorescent lamp) that are normally fitted with a functional component (a lamp, a starter, and similar components during use of the unit is not required to be additionally enclosed.

Exception No. 2: A component, such as a ballast, that has an integral outer housing that has been evaluated as an enclosure is not required to be additionally enclosed.

Exception No. 3: The power-supply cord is not required to be contained within the unit.

Exception No. 4: A wire with minimum 1/32 inch (0.79 mm) thermoplastic insulation is not prohibited from being exposed for 2 inches (50.8 mm) or less when it is securely held in place and is routed in close proximity to a portion of the lamp such that the risk of being inadvertently snagged is minimized.

Exception No. 5: A wire or bundle of wires for a lamp supported lampholder is not prohibited from being exposed when:

- a) The exposed wire or bundle of wires is covered with a glass fiber sleeve or thermoplastic tubing that extends from a point inside the enclosure to within 1/2 inch (12.7 mm) of the lampholder, and the sleeving has a wall thickness of at least 0.017 inch (0.42 mm);*
- b) The hole in the housing through which the nonenclosed wires emerge is not larger than 5/8 inch (15.9 mm) diameter, or has an area of 0.31 square inch (200 mm²) when other than round in shape; and*
- c) The wires are provided with a strain relief device at the portable luminaire end, and the device complies with the Strain Relief Test in Section 133.*

Exception No. 6: A wire or cord with a minimum 1/32 inch (0.79 mm) thermoplastic insulation and an insulation-piercing or a crimp connector having all live parts of the connector and the conductors insulated are only required to be housed within the unit such that they are unable to be grasped, pulled, or inadvertently snagged. For instance, it meets the intent of the requirement to have a metal base with a felt pad for a bottom cover where the felt pad is secured by an adhesive and the weight of the unit.

10 Metal Thickness for Enclosures

10.1 The thickness of sheet metal used in a portable luminaire shall not be less than specified in Table 10.1.

Exception No. 1: A form of construction that uses metal having a thickness less than specified is able to be used when investigated and found to comply with the applicable tests in Metal Thickness Equivalency Tests, in the Standard for Luminaires, UL 1598.

Exception No. 2: The thickness of metal is not specified for:

- a) A decorative part;*
- b) A reflector part that does not form part of the enclosure; or*
- c) Any part not required to serve as the enclosure, provide structural integrity, or act as support of a wiring device.*

Table 10.1
Thickness of sheet metal

Largest dimension	Conditions of use	Minimum thickness of sheet metal					
		Uncoated		Zinc-coated		Copper, brass, or aluminum	
		Inch	(mm)	Inch	(mm)	Inch	(mm)
Not more than 26 inches (660 mm)	Component Support	0.020	(0.51)	0.023	(0.58)	0.025	(0.64)
		0.016 ^a	(0.41) ^a	0.019 ^a	(0.48) ^a	0.020 ^a	(0.51) ^a
	No Component Support	0.016	(0.41)	0.019	(0.48)	0.020	(0.51)
		0.013 ^a	(0.33) ^a	0.016 ^a	(0.41) ^a	0.016 ^a	(0.41) ^a
Not more than 50 inches (1.27 m)	Component Support	0.026	(0.66)	0.029	(0.74)	0.032	(0.81)
		0.020 ^a	(0.51) ^a	0.023 ^a	(0.58) ^a	0.025 ^a	(0.64) ^a
	No Component Support	0.020	(0.51)	0.023	(0.58)	0.025	(0.64)
		0.016 ^a	(0.41) ^a	0.019 ^a	(0.48) ^a	0.020 ^a	(0.51) ^a
More than 50 inches (1.27 m)	Component Support	0.042	(1.07)	0.045	(1.14)	0.050	(1.27)
		0.031 ^a	(0.79) ^a	0.034 ^a	(0.86) ^a	0.040 ^a	(1.02) ^a
	No Component Support	0.031	(0.79)	0.034	(0.86)	0.040	(1.02)
		0.026 ^a	(0.66) ^a	0.029 ^a	(0.74) ^a	0.032 ^a	(0.81) ^a

^a Only when the surface involved is curved, ribbed, flanged, or reinforced with additional metal. A surface is determined to be flanged when the two opposite longer sides are bent at right angles to the surface to form 1/2 inch (12.7 mm) or wider flanges.

10.2 Table 10.1 applies to any single surface or single flat sheet. Values for the thickness of sheet steel are based on uncoated material. Rigid members consisting of 1/2 by 1/2 inch (12.7 by 12.7 mm), 90 degree angle strips formed of sheet steel not less than 0.031 inch (0.79 mm) thick, or flat steel bars not less than 3/8 inch (9.5 mm) wide and 1/8 inch (3.2 mm) thick shall be used to reinforce and divide a larger

area into sections for which lighter metal is able to be used. Such reinforcement, unless along the greater dimension of the surface, shall also be secured to the adjacent sides of the enclosure. A single sheet of metal having a bent corner that forms an angle of not more than 120 degrees is determined to be reinforced at that corner, and the thickness is based on the length and area of the maximum flat surface involved.

10.3 The minimum thickness of cast metal shall be in accordance with Table 10.2.

Table 10.2
Thickness of cast metal

Metal	Minimum thickness, inch (mm)			
	At unreinforced areas		At all other areas ^a	
Die-cast metal	5/64	(2.0)	3/64	(1.2)
Cast malleable iron or permanent mold cast aluminum	3/32	(2.4)	1/16	(1.6)
Other cast metal	1/8	(3.2)	3/32	(2.4)

^a Applicable for the base of threads, and for surfaces that are curved, ribbed, or otherwise reinforced so as to meet the intent of the requirements, or for a surface of such shape or size that the required mechanical strength is provided.

10.4 Metallic tubing shall not be less than 0.040 inch (1.02 mm) thick when cut threads are employed.

10.5 Unthreaded metallic tubing or metallic tubing having rolled threads shall not be less than 0.025 inch (0.64 mm) thick.

10.6 The thickness of tubing is to be measured with a round-nose micrometer.

10.7 An enclosure, a frame, a guard, a handle, or similar part shall not be to constitute a risk of injury to persons in normal maintenance and use.

11 Corrosion Protection

11.1 Each external iron or steel surface of a portable luminaire enclosure or wireway shall be protected from corrosion.

Exception No. 1: Enclosed steel pipe stems are not required to be protected against corrosion.

Exception No. 2: Threaded holes and the cut edges and punched holes of an enclosure, and similar parts, formed of galvanized stock are not required to be protected against corrosion.

Exception No. 3: Cast materials are not required to have corrosion protection.

12 Polymeric Enclosures

12.1 A polymeric material, used as a part or all of the enclosure of a portable luminaire as specified in Enclosures, Section 9, shall have:

- a) Mechanical temperature indexes (including impact) as a result of long term aging as described in the Standard for Polymeric Materials – Long Term Property Evaluations, UL 746B; and
- b) Been evaluated for use in portable luminaires in accordance with the Standard for Polymeric Materials – Use in Electrical Equipment Evaluations, UL 746C.

Exception No. 1: A polymeric material used as an enclosure for a dry location unit does not require the volume resistivity test.

Exception No. 2: The distortion under load test is not required when the mold stress relief test is conducted.

Exception No. 3: For units which are not mounted to a surface, the impact test shall include the drop test, and the ball impact test is not required.

Exception No. 4: The mold-stress relief distortion test shall be conducted using the air-oven method only. The test-cell method is not required.

Exception No. 5: The input after mold stress relief distortion, the abnormal conditions test, and the severe conditions test are not required.

Exception No. 6: The mold stress relief distortion test is not required on extruded or protruded materials.

12.2 A polymeric material is relied upon to provide all or a portion of the strain relief, shall comply with the requirements of the Strain Relief Test, Section 133, after the Mold Stress Relief Distortion Test in the Standard for Polymeric Materials – Use in Electrical Equipment Evaluations, UL 746C.

13 Polymeric Decorative Parts

13.1 A decorative part of polymeric material located near a lamp or other component that generates heat shall:

- a) Be present on the portable luminaire when it is temperature tested in accordance with the Normal Temperature Test, Sections 124 – 128; and
- b) Not melt or deform in any way that interferes with the normal operation of the unit or results in a risk of fire or electric shock during the temperature test.

14 Enclosure Openings

14.1 An opening in a portable luminaire enclosure described in Enclosures, Section 9, shall comply with the requirements for the Accessibility of Live Parts, Section 23.

14.2 An enclosure containing an open core-and-coil device shall not contain open holes or open seams.

Exception No. 1: An opening provided for an automatic starter meets the intent of the requirement when it is no more than 1/8 inch (3.2 mm) diameter larger than the diameter of the starter.

Exception No. 2: Openings provided in through-cord transformers or direct plug-in transformers meet the intent of the requirement when the transformer complies with the Standard for Power Units Other Than Class 2, UL 1012, the Standard for Class 2 Power Units, UL 1310, or the Standard for Class 2 and Class 3 Transformers, UL 1585.

Exception No. 3: A unit that incorporates an open coil type transformer or power supply is able to have open holes in the enclosure as specified in Table 14.1 when the transformer has been determined to comply with the abnormal test specified in the Standard for Transformers and Motor Transformers for Use in Audio-, Radio-, and Television-Type Appliances, UL 1411, abnormal and short circuit test in the Standard for Transformers, Class 2 and Class 3, UL 1585, or when a power supply has been investigated to determine compliance with the abnormal, burnout, and short-circuit tests specified in the Standard for Power Supplies, UL 1012, or the Standard for Class 2 Power Units, UL 1310.

Exception No. 4: An enclosure of an open coil ballast or transformer is able to open holes in its surface when a metal baffle is provided that complies with Figure 14.1 and the following:

- a) The distance between the baffle and the outer enclosure, X, shall not exceed 1/4 inch (6.4 mm).*
- b) The dimensions of the baffle, Y, shall be at least the cross-sectional dimensions of the live part.*
- c) The distance where the enclosure overlaps the baffle, Z, shall be at least two times the distance between the baffle and the outer enclosure (X).*

Exception No. 5: A fluorescent unit that incorporates an open coil type ballast is able to have open holes in the enclosure as specified in Table 14.1 when the ballast complies with the Class P requirements of the Standard for Fluorescent-Lamp Ballasts, UL 935.

Table 14.1
Maximum size of miscellaneous open holes

Opening shape	Dimension		Maximum area	
	Inch	(mm)	in ²	(cm ²)
Slot ^a	3/8	(9.6)	1-1/2	(9.68)
Square	1/2	(width)	-	-
		(side)		
Round	1/2	(12.7)	-	-
Irregular	-	(diameter)	1-1/2	(9.68)
		-		

^a An open hole between two assembled parts that does not exceed 1/32 inch (0.8 mm) is not required to comply with the area limitation.

Figure 14.1
Relationship of baffle and electrical part to prevent emission

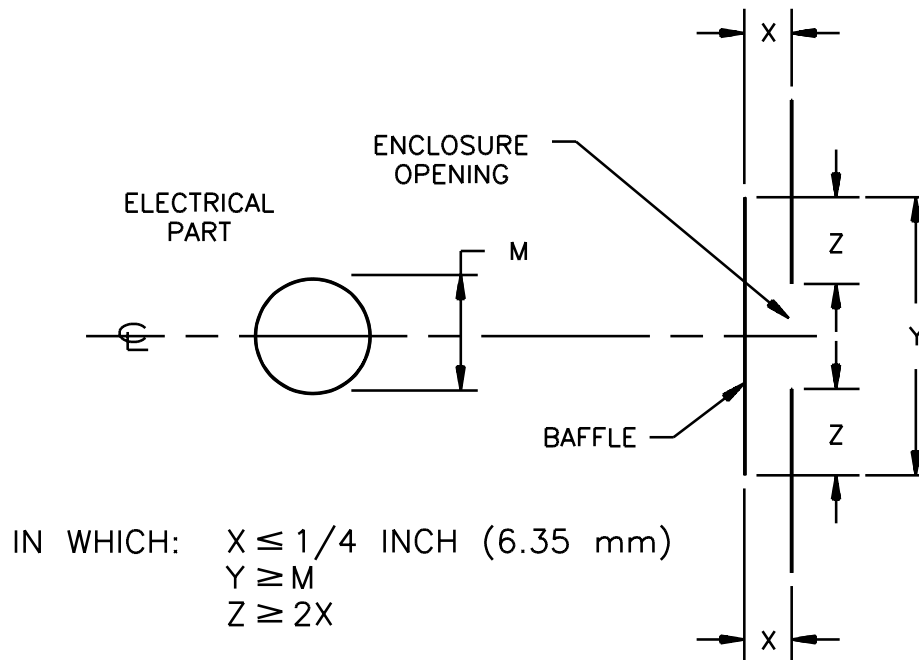

S3373

14.3 An enclosure shall not contain any opening that is usable for mounting the portable luminaire.

Exception No. 1: A blind opening that prevents access to the actual enclosure is not prohibited.

Exception No. 2: A keyhole slot is not prohibited from being open when it is in accordance with 69.2.1(a).

15 Wireways and Tubing

15.1 A portable luminaire shall be constructed so that when wires are pulled through, or the unit otherwise wired, the covering or insulation on the conductors are not damaged against any surface they are able to contact. Also see Protection of Wiring, Section 30 for additional requirements.

15.2 Wireways shall be free from burrs and fins.

15.3 Tubing that is used as a wireway shall be free from kinks and cracks.

15.4 Screw threads of sheet metal screws and self-tapping screws shall not be exposed for a distance of more than 3/16 inch (4.8 mm) in a wireway.

Exception: The screw threads are not prohibited from being exposed for more than 3/16 inch (4.8 mm) when the wires are held away from or prevented from contacting the screw threads.

16 Shade Construction

16.1 A portable luminaire shall be shipped with a shade unless:

- a) The shade functions only as a decorative part; and
- b) Instructions are provided in accordance with 184.1.

16.2 A portable luminaire complying with the Temperature Test-Exempt Units requirements of Sections 47 or 60 is able to have a shade constructed of any material.

16.3 A shade shall reliably maintain its dimensions. For example, a breeze shall not be able to blow the cloth of a cloth shade closer to the lamp.

Exception: A shade is not required to reliably maintain its dimensions when the shade is used in accordance with the requirements for the minimum possible dimensions the shade is capable of attaining.

16.4 A dust cover is able to be provided over a shade only when instructions for removal are provided in accordance with 170.3.

Exception: The instructions are able to omitted when the dust cover does not restrict or reduce the required open area of the shade.

17 Strain Relief

17.1 A portable luminaire shall be provided with strain relief so that a pull exerted on the power supply cord is not transmitted directly to a terminal splice, or interior wiring of the unit. See Strain Relief Test, Section 133.

Exception No. 1: Additional strain relief is not required to be provided when the conductors of the supply cord are permanently assembled to a wiring device (such as a switch), lampholder, or similar device by the manufacturer of the wiring device, in such a manner that replacement of the cord requires the disassembly of the device by the removal of a rivet, drive screw, drive pin, or similar component.

Exception No. 2: Additional strain relief is not required to be provided when a lampholder has insulation piercing terminals and is identified as not requiring an additional strain relief device.

17.2 A metal strain-relief clamp or band used with Type SP-2 or lighter general-use, rubber-insulated cord shall be provided with auxiliary insulation over the cord for mechanical protection.

Exception: The auxiliary insulation is able to be omitted for Type SV or SVO cord.

17.3 A clamp of any material (metal or otherwise) shall not be used with Type SPE-2, SPT-2, SVT, or SVTO cord.

Exception No. 1: The construction is able to be evaluated for use when the cord is protected by varnished-cloth or similar material under the clamp.

Exception No. 2: A strain-relief bushing of insulation material that has been investigated for the purpose is able to be used.

17.4 For thermoplastic-insulated cord heavier than Type SPT-2, SVT, or SVTO, a clamp is able to be used with no auxiliary insulation unless it is tested and determined to damage the cord insulation. See Strain Relief Test, Section 133.

17.5 When a knot in a flexible cord serves as strain relief, any surface against which the knot is able to bear or with which it is able to come in contact shall be free from projections, sharp edges, burrs, fins and similar conditions, that are capable of damaging the insulation on the conductors.

18 Portable Luminaires Having Play Value

18.1 A portion of a portable luminaire that has play value for children eight years or less in age and is intended to be removed from the unit and played with (for example a plush doll not integral with the luminaire) shall comply with the Federal Regulations for toys and children's articles. It is not possible to specify the conditions of tests for all constructions; however, the tests shall include evaluation of impact, bite, flexure, torque, tension, compression, sharp point, sharp edge, and small parts.

18.2 The portable luminaire shall not overturn when tested in accordance with the Stability Test, Section 132, with a 15 degree inclined plane.

18.3 A toy or stuffed animal suspended from a unit shall be designed for unexpected, forceful removal and shall comply with the requirements in the Test for Suspended Toys, Section 158.

18.4 The portable luminaire shall be marked in accordance with the requirements in 169.11.

Exception: The marking is able to be modified to indicate that the risks are associated with the luminaire portion and not to the separable portion having play value.

19 Resistance to Liquid Damage

19.1 When a portable luminaire is intended to be used where the deterioration or breakage of a liquid container, seal, or similar component increases the risk of electric shock or liquid spillage, the container, seal, or similar component shall be resistant to deterioration from the liquid intended to be used in contact with that component. The liquid shall be evaluated with respect to its toxic, acid, alkaline, flame and conductive properties. The determination of resistance to deterioration is based upon the material comprising the container, seal, or similar component, its size and shape, the mode of application, and other factors.

19.2 A portable luminaire (such as a plant lamp) using insulating material that is capable of being adversely affected by moisture under its intended operating conditions shall be investigated in accordance with the Resistance to Moisture Test, Section 140.

20 Portable Luminaire Containing Hazardous Substance

20.1 A portable luminaire containing a hazardous substance, such as the mixture of chemicals used as decorative fluid in lava-type lamps, shall be evaluated with respect to ease of ignition, and whether the substance is toxic. The risk of injury shall be assessed on the basis of the amount of the substance or concentration and a one time exposure due to an accidental spill. Inhalation of vapors, contact with skin or eyes, and ingestion are to be considered as probable events. Chemical changes due to exposure to light (UV) and heat (operating temperature) also are to be determined.

20.2 A container of a hazardous substance shall not be adversely affected by the substance. Gaskets, seals, and caps shall not be adversely affected by the substance.

20.3 Soft glass shall not be used as a container of a hazardous substance.

20.4 The unit shall comply with the marking in 169.12.

ELECTRICAL CONSTRUCTION – GENERAL

21 General

21.1 These requirements apply to all portable luminaires and shall be used in conjunction with the applicable supplementary requirements in this Standard.

22 Assembly and Packaging

22.1 A portable luminaire shall be completely wired with each electrical component mounted in place and with each splice and connection completed.

Exception No. 1: A detachable power-supply cord is able to be disconnected from the product, as long as it is packaged with the product.

Exception No. 2: A portable luminaire consisting of a wiring harness that snap-fits into a decorative housing is not required to be assembled when such assembly precludes required packaging of the housing for shipping. For example, a ceramic or glass figurine requires packaging material inside and outside to prevent breakage during shipping.

Exception No. 3: Pendant switches (through cord) are able to be shipped unattached with the unit when installation instructions are included to indicate the intended power supply cord is Type SPT-2.

23 Accessibility of Live Parts

23.1 Each part or device that is required by Enclosures, Section 9, to be enclosed shall be located or shielded so that it is not accessible to unintentional contact by persons during normal use, including relamping, replacement of an automatic starter, or other user maintenance services.

Exception No. 1: An uninsulated live part that operates at a potential of 30 volts rms or less and 42.4 volts peak and is able to be accessible in accordance with Secondary Low Voltage Circuits, Section 38.

Exception No. 2: Wiring that is visible and follows the contour of the portable luminaire is able to be accessible during relamping, when it is not spliced and strain relief is maintained at all wiring terminations.

23.2 A live part is determined to be inaccessible when a probe as illustrated in Figure 23.1 is unable to be manipulated such that it touches any part. The probe is to be articulated into any configuration and rotated or angled to any capable position before, during, or after inserting into the opening.

Figure 23.1
Accessibility probe

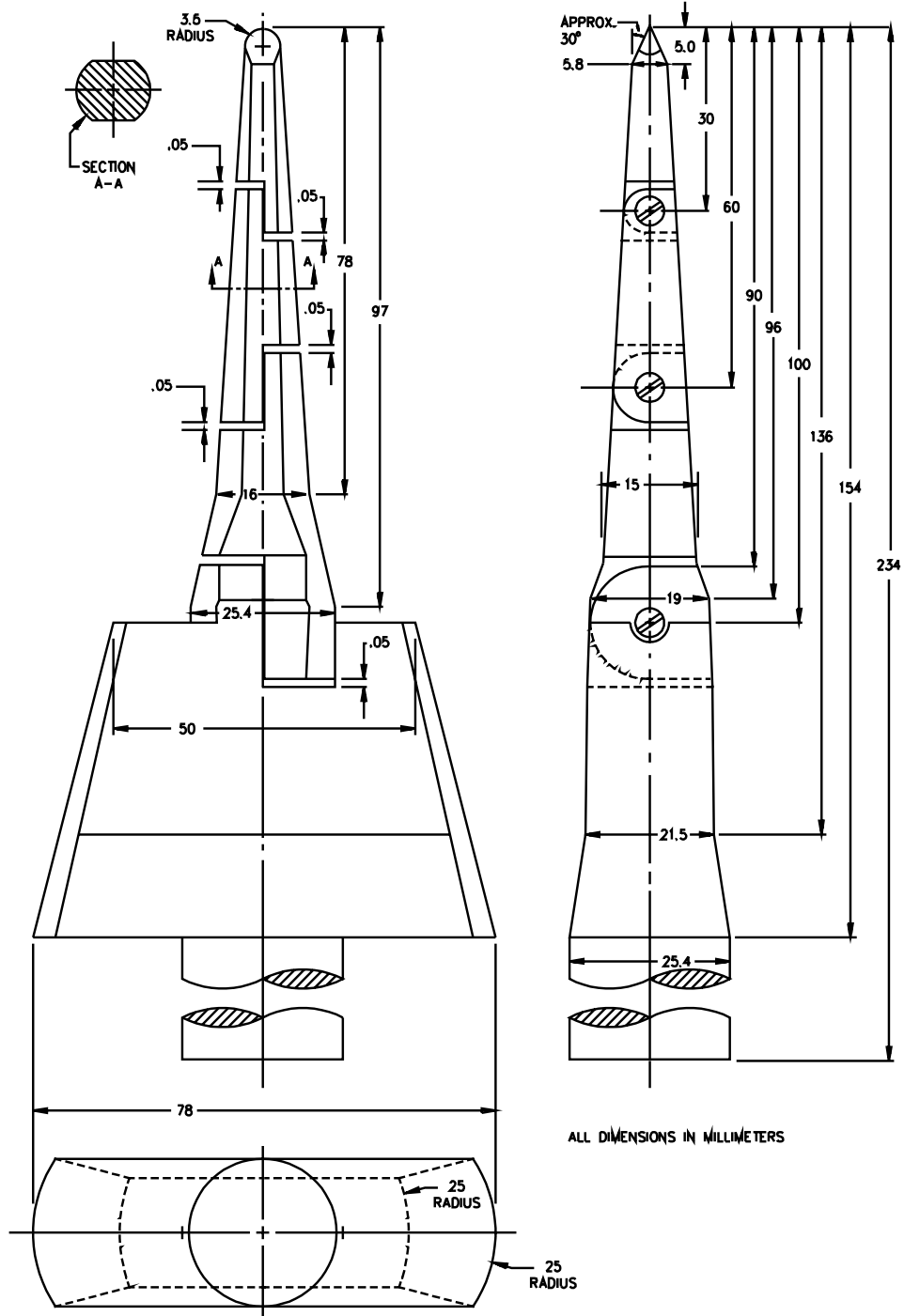

PA100A

23.3 All parts that are removable without the use of tools shall be removed when determining accessibility in accordance with 23.2.

Exception No. 1: A phenolic or metal lampholder shell that is secured by a twist or snap-fit does not require removal.

Exception No. 2: An automatic starter does not require removal.

24 Electrical Spacings

24.1 The spacing between uninsulated live parts of opposite polarity, and between uninsulated live parts and metal that is capable of being grounded shall not be less than 1/4 inch (6.4 mm) through air or 3/8 inch (9.5 mm) over surface. The outer wrap of an open core and coil ballast is determined to be an uninsulated live part with respect to this requirement.

Exception No. 1: The spacing requirements do not apply between uninsulated live parts of a wiring device, such as a lampholder or switch, and dead metal that is part of the wiring device and including mounting screws, rivets, yoke, clamp, or similar components; or for a portable luminaire provided with a grounding means between such live parts and that part of the dead metal surface of the portable luminaire on which the device is mounted in its intended manner. See Figure 24.1.

Exception No. 2: When an isolated dead metal part is interposed between or is in close proximity to:

- a) Live parts of opposite polarity;*
- b) A live part and an exposed dead metal part; or*
- c) A live part and a dead metal part that is able to be grounded, the spacing shall not be less than 3/64 inch (1.2 mm) between the isolated dead metal part and any one of the other parts previously mentioned, provided the total spacing between the isolated dead metal part and the two other parts is not less than 1/4 inch (6.4 mm) through air or 3/8 inch (9.5 mm) over surface.*

Exception No. 3: The spacing between uninsulated live parts of a Class 2 circuit and between such parts and dead metal that is grounded in service is not specified.

Figure 24.1
Spacings of components

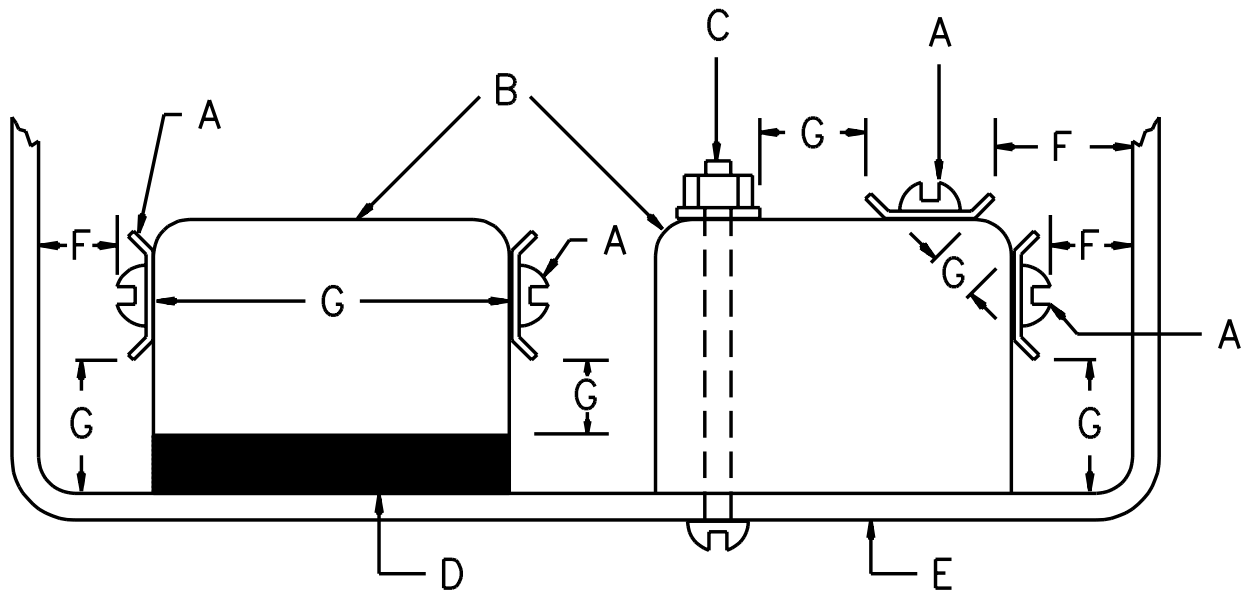

SM100

- A. Uninsulated live parts of wiring device.
- B. Insulating material of wiring device.
- C. Mounting screw of wiring device.
- D. Dead metal part of wiring device.
- E. Dead metal parts of portable luminaire.
- F. Spacings to which Figure 24.1 applies.
- G. Spacings to which Figure 24.1 does not apply. See Exception No. 1 to 24.1.

24.2 When an uninsulated live part is not rigidly fixed in position by means other than friction between surfaces, or when a movable dead metal part is in proximity to an uninsulated live part, the construction shall be such that the required minimum spacing is maintained.

25 Insulating Materials

25.1 A polymeric material used as an electrical insulator, or as direct or indirect support of a live part, shall comply with the requirements in the Standard for Polymeric Materials – Use in Electrical Equipment Evaluations, UL 746C.

25.2 An insulating lining or barrier of vulcanized fiber or similar materials used where spacing does not otherwise comply with the requirement shall not be less than 1/32 inch (0.8 mm) thick, and shall be so located that it is not adversely affected by arcing, except that vulcanized fiber not less than 1/64 inch (0.4 mm) thick is able to be used in addition to an air spacing of not less than 50 percent of the spacing required for air alone.

Exception: Insulating lining or barrier of vulcanized fiber or similar material in accordance with 17.3 is not required to comply with this requirement.

26 Electrical Ratings

26.1 Each electrical device and insulated conductor shall have a voltage rating at least equal to the voltage applied to it in normal use.

26.2 Each electrical device shall have an ampere rating and each insulated conductor shall have an ampacity rating for the maximum current to which it is subjected in normal use.

26.3 The ampere rating of the portable luminaire shall be calculated by adding the ratings of all of the following that are provided on the unit:

- a) Fifteen amperes for one or two single receptacles or for each duplex receptacle;

Exception: The marked rating of the receptacle is usable when the receptacle is marked in accordance with the Exception to 169.6.3.

- b) The ampere rating of each ballast;
- c) The calculated load of each line voltage incandescent lampholder is to be determined by dividing the marked wattage rating by 120 volts;
- d) The ampere rating of each transformer; and
- e) The ampere rating of any other line-voltage parts, such as a clock, a motor, and similar parts.

26.4 The ampacity rating of an insulated conductor shall be as specified in Table 26.1.

Table 26.1
Ampacities of wires and cords with copper conductors

Types of wire and cord ^a	Ampacity			
	18 AWG (0.82 mm ²)	16 AWG (1.3 mm ²)	14 AWG (2.1 mm ²)	12 AWG (3.3 mm ²)
Fixture wires –	6	8	17	23
Flexible cords – As specified in Table 31.1	10	13	18	25
Appliance wiring material	6	8	17	23

^a Some of the types of wire and cord are not made in each of the sizes shown. For each such type and size, the ampacity shown is inapplicable.

27 Wiring and Conductors

27.1 Conductor size

27.1.1 A conductor of a wire or cord shall be No. 18 AWG (0.82 mm²) or larger. See Electrical Ratings, Section 26.

27.1.2 A conductor smaller than No. 18 AWG (0.82 mm²) is able to be used for internal wiring when it is investigated and found to meet the requirements for the intended application; for example, consideration is to be given for internal fusing, lead routing, and degree of enclosure required under any condition of loading, including short circuit and abnormal operation.

27.1.3 A conductor smaller than No. 18 AWG (0.82 mm²) and not smaller than No. 24 AWG (0.21 mm²) is usable as a permanently attached lead for a clock motor or a transformer when:

- a) The lead is completely enclosed;
- b) The lead is not more than 6 inches (152 mm) long; and
- c) Stalling of the clock motor, or any load on the secondary of the transformer, including a short circuit, does not result in a risk of fire.

27.1.4 A conductor smaller than No. 18 AWG (0.82 mm²) and not smaller than No. 24 AWG (0.21 mm²) is usable in a low voltage Class 2 power limited circuit.

27.2 Temperature rating

27.2.1 The temperature ratings of commonly used flexible cords and fixture wires are specified in Table 27.1.

Table 27.1
Temperature and voltage ratings of wire and cord

Temperature rating	Insulation	300 volts	600 volts
60°C (140°F)	Wire Cord ^d	– C ^{a,e} , PD ^{a,e} , NISP-1 ^e , NISP-2, NISPT-1 ^e , NISPT-2, SJ, SJO, SJOO, SJT, SJTO, SJTOO, SP-1 ^e , SP-2, SPT-1 ^e , SPT-2, SV, SVO, SVOO, SVT, SVTO, SVTOO, Style 2388 ^{e,d}	TF, TFF, TW S, SO, SOO, ST, STO, STOO
75°C (167°F)	Wire Cord	– NISP-1 ^{e,b} , NISP-2 ^b , NISPT-1 ^{e,b} , NISPT-2 ^b , SJ ^b , SJO ^b , SJOO ^b , SJT ^b , SJTO ^b , SJTOO ^b , SP-1 ^{e,b} , SP-2 ^b , SPT-1 ^{e,b} , SPT-2 ^b , SV ^b , SVO ^b , SVOO ^b , SVT ^b , SVTO ^b , SVTOO ^b , Style 2388 ^{b,d,e}	RFH-2, RH, RHW, THW, THWN S ^b , SO ^b , SOO ^b , ST ^b , STO ^b , STOO ^b
90°C (194°F)	Wire ^c Cord ^b	– HPD, HPN, HJS, HS, HSO, HSJO, NISP-1 ^{b,e} , NISP-2 ^b , NISPE-1 ^e , NISPE-2, NISPT-1 ^{b,e} , NISPT-2 ^e , SJ ^b , SJE, SJEO, SJO ^b , SJOO ^b , SJT ^b , SJTO ^b , SJTOO ^b , SP-1 ^{b,e} , SP-2 ^b , SPE-1 ^e , SPE-2, SPT-1 ^{b,e} , SPT-2 ^b , SV ^b , SVE, SVE0, SVO ^b , SVOO ^b , SVT ^b , SVTO ^b , SVTOO ^b , Style 2388 ^{b,d,e}	FEB, FEPB, PFA, RHH, RHW-2, SA, SIS, TBS, TFN, TFFN, THHN, THHW, THW-2, THWN-2, XHH, XHHW, XHHW-2, Z, ZW S ^b , SE, SEO, SO ^b , SOO ^b , ST ^b , STO ^b , STOO ^b
105°C (221°F)	Cord ^{c,d}	HPD ^{a,b} , HPN ^b , HJS ^b , HS ^b , HSO ^b , HSJO ^b , NISP-1 ^{b,e} , NISP-2 ^b , NISPE-1 ^{b,e} , NISPE-2 ^b , NISPT- 1 ^{b,e} , NISPT-2 ^b , SJ ^b , SJE ^b , SJEO ^b , SJO ^b , SJOO ^b , SJT ^b , SJTO ^b , SJTOO ^b , SP-1 ^{b,e} , SP-2 ^b , SPT-1 ^{b,e} , SPT-2 ^b , SPE-1 ^{b,e} , SPE-2 ^b , SV ^b , SVE ^b , SVEO ^b , SVO ^b , SVOO ^b , SVT ^b , SVTO ^b , SVTOO ^b , Style 2388 ^{b,d,e}	S ^b , SE ^b , SEO ^b , SO ^b , SOO ^b , ST ^b , STO ^b , STOO ^b
150°C (302°F)	Wire	XF, XFF	PF, PFF, PGF, PGFF, PTF, TFE
200°C (392°F)	Wire	KF-1, KFF-1, SF-1, SFF-1	KF-2, KFF-2, SF-2, SFF-2
250°C (482°F)	Wire	–	PFAH ^f , PTF ^f
<p>^a Not for use in portable luminaires intended to be used in locations that may be affected by moisture, such as a plant luminaire.</p> <p>^b Only when surface marked "75°C," "90°C," or "105°C", whichever is applicable.</p> <p>^c See 27.2.5 for increased temperature ratings by use of sleeving.</p> <p>^d An appliance wiring material complying with Figure 27.1.</p> <p>^e Not for use as power supply cord.</p>			

Table 27.1 Continued on Next Page

Table 27.1 Continued

Temperature rating	Insulation	300 volts	600 volts
^f Not for use in wet location luminaires except when wire is totally contained within and water does not enter the unit during the rain and sprinkler tests.			

27.2.2 Appliance wiring material (AWM) which is suitable for internal wiring and accessible wiring, but not power supply cord is described in Figure 27.1.

Figure 27.1
Specifications for appliance wiring material

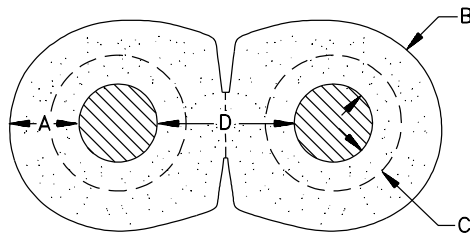

S3527

A – Minimum acceptable average thickness away from tear area and outside point – 0.040 inch (1.02 mm).

B – Minimum acceptable thickness at any point (before separation) – 0.035 inch (0.89 mm).

C – Minimum acceptable thickness at any point after separation – 0.019 inch (0.49 mm).

D –

(1) Minimum acceptable distance between copper conductors – 0.060 inch (1.52 mm).

(2) Stranding shall consist of Nos. 36 – 34 AWG (0.013 – 0.020 mm²) strands.

27.2.3 Wire or cord other than those specified in Table 27.1 is usable when:

- a) The insulation of the wire or cord is rated for the maximum temperature involved;
- b) The temperature for which the wire or cord is rated is:
 - 1) Identified by a colored thread or a colored stripe as described in 27.2.4; or
 - 2) Printed on the surface of the insulation;
- c) The insulation of the wire or cord is:
 - 1) Rated for the maximum voltage involved and not less than 300 volts; and
 - 2) When of rubber or thermoplastic, provided with an overall braid;

Exception: Thermoplastic insulation rated for use at 600 volts or more is not required to be provided with a braid.

27.2.4 With reference to 27.2.3(b)(1) when a colored thread or stripe is used to identify the temperature rating of a wire or cord:

- a) For a rubber-insulated wire or cord, green indicates a 75°C (167°F) rating.
- b) For a thermoplastic-insulated wire or cord:
 - 1) No identification is required for 80°C (176°F), and when identification is provided, blue is used;
 - 2) Red indicates a 90°C (194°F) rating;
 - 3) Yellow indicates a 105°C (221°F) rating;
 - 4) Brown indicates a 125°C (257°F) rating;
 - 5) Orange indicates a 150°C (302°F) rating; and
 - 6) Black indicates a 200°C (392°F) rating.

27.2.5 Wiring or cord rated minimum 90°C (194°F) usable at 150°C (302°F) when each individual conductor is provided with sleeving:

- a) Consisting of snug fitting:
 - 1) Woven-glass sleeving not less than 0.010 inch (0.25 mm) thick; or
 - 2) Woven-glass tape applied in two or more layers having a total thickness of not less than 0.010 inch; and
- b) Extending from the terminals of the lampholder to the point where the wire emerges from the shade or at least 3 inches (76 mm).

28 Splices and Connections

28.1 Stranded conductors of cord or wire intended for connection to a screw terminal shall be twisted and solder-dipped or otherwise treated so as to bind all strands for at least 1/8 inch (3.2 mm) from the end of the stripped conductor prior to connection of the conductor to the terminal so that the strands do not splay during the assembly operation.

28.2 A splice shall be mechanically and electrically secure and, unless a wire connector is used that meets the intent of this requirement shall be soldered. A wire soldered inside an eyelet terminal or similar movement confining part is determined to be mechanically and electrically secure.

28.3 A soldered splice and a splice made with an uninsulated wire connector shall be covered with insulation that has a temperature rating and thickness equivalent to that required on the conductors.

28.4 In determining compliance with 28.3, general-use insulating tape is determined to be rated 80°C (176°F), and usable for 150 volts when wrapped at least once on itself.

28.5 An insulated wire connector shall be rated for the required temperature and voltage of the conductors involved.

28.6 A splice shall not be located in an arm or a stem.

Exception: A splice is able to be located in an arm or stem if the splice is not accessible and under strain.

28.7 Quick-connect terminals shall be nominally 0.110 (2.80 mm), 0.125 (3.18 mm), 0.187 (4.75 mm), 0.205 (5.21 mm), or 0.250 (6.35 mm) inch wide and shall comply with the Standard for Electrical Quick-Connect Terminals, UL 310. Other sizes of quick-connect terminals shall be investigated with respect to crimp pullout, engagement-disengagement forces of the connector and tab, and temperature rise; all tests shall be conducted in accordance with UL 310.

29 Wiring Attached to Movable or Flexible Parts

29.1 Internal wiring attached to a movable or a flexible part that is capable of being bent shall be:

- a) Stranded; and
- b) Secured so that:
 - 1) The wiring is not cut or abraded; and
 - 2) There is no strain or motion at the connections.

29.2 The requirement in 29.1 applies only to constructions in which the wire or cord is capable of being bent, as in an enclosed swivel joint, or where a sharp bend occurs in a wire or cord between two points of restraint that are 6 inches (152 mm) or less apart.

29.3 Type SV, SVO, SVOO, SVT, SVTO, or SVTOO cord shall not be attached to a movable or a flexible part in such a way that the cord is capable of being sharply bent.

30 Protection of Wiring

30.1 A power-supply cord shall exit the portable luminaire through an opening that is free from sharp edges, burrs, and fins that are able to damage the conductor insulation.

30.2 The power-supply cord shall be provided with mechanical means that prevent the cord being pushed inside the enclosure and contacting:

- a) A lamp or heated surface;
- b) Sharp edge; or
- c) Moving part.

30.3 An insulating bushing shall be provided where the flexible cord or wiring enters a pendant lampholder or the base or stem of a portable luminaire, and at the ends of metal tubing where the cord or wiring are pulled during the adjustment of the unit.

Exception No. 1: A smooth, metal bushing is able to be used when Type SPT-2, SJ, SV, or heavier cord is used.

Exception No. 2: An insulating bushing is not required with Integral Type SP-1, SP-2, SPT-1, or SPT-2 cord or appliance wiring material complying with Figure 27.1 when:

- a) The metal through which the cord passes is not less than 0.042 inch (1.07 mm) thick and the surface is smooth, or the edge of the metal is rolled not less than 120 degrees; or*
- b) The cord at the point where it passes through the hole is provided with additional insulation that is:*
 - 1) Not less than 1/32 inch (0.8 mm) thick;*
 - 2) Molded to the cord; and*
 - 3) Of rubber for Type SP-1 and SP-2 cord and thermoplastic for Type SPT-1 and SPT-2 cord, and appliance wiring material complying with Figure 27.1.*

30.4 Cord or wiring that passes through tubing or contacts the edge of a sheet-metal wall 0.042 inch (1.07 mm) or less thick shall be reliably held away from the edges of the metal or shall be protected by a nonrubber bushing or a grommet or by rolling the edge of the metal not less than 120 degrees.

30.5 When cords or wires pass through or contact the edges of sheet metal thicker than 0.042 inch (1.07 mm), the metal shall be treated by reaming or the equivalent to remove burrs, fins, or sharp edges that are able to damage insulation.

30.6 When the material through which the cord or wiring passes is wood, porcelain, phenolic composition, or other insulating material, not less than 3/64 inch (1.2 mm) thick, a smoothly rounded surface is determined to be equivalent to a bushing.

30.7 Ceramic materials and molded urea, phenolic, and melamine compositions are determined to meet the intent of the requirement for insulating bushings; a bushing of wood or rubber is not usable. Other compositions are able to be used when they have been investigated and found usable for the application.

30.8 A hard-fiber bushing is able to be employed when the bushing is not less than 3/64 inch (1.2 mm) thick.

30.9 An insulated metal grommet is usable in place of an insulating bushing when the insulating material used is not less than 1/32 inch (0.8 mm) thick and completely fills the space between the grommet and the metal in which it is mounted.

30.10 Polymeric sleeving shall not be used for reducing the risk of cutting or abrasion of wiring. Fiberglass sleeving not less than 0.010 inch (0.25 mm) thick is capable of being used.

30.11 A bushing shall be securely held in place.

31 Power-Supply Cords

31.1 A portable luminaire shall be provided with a power supply cord consisting of one of the types of flexible cords specified in Table 31.1 and an attachment plug rated as required for the application.

Exception: A power-supply cord complying with Alternate Power-Supply Connections, Section 34, is not required to comply with this requirement.

Table 31.1
Flexible cord types

S	SJ	SP-2	SV ^a
SE	SJE	SPE-2	SVE ^a
SEO	SJEO	SPT-2	SVEO
SO	SJO		SVO ^a
SOO	SJOO		SVOO ^a
ST	SJT		SVT ^a
STO	SJTO		SVTO ^a
STOO	SJTOO		SVTOO ^a

^a Individual conductors shall be provided with supplementary insulation or spaced away from metal.

31.2 A power-supply cord shall not be smaller than No. 18 AWG (0.82 mm²).

31.3 A power-supply cord shall be at least 5 feet (1.5 m) long measured from the point where the cord emerges from the body of the lamp to the face of the attachment plug or connector.

Exception: A power-supply cord in accordance with Alternate Power-Supply Connections, Section 34, is not required to comply with this requirement.

31.4 The conductors of the power supply cord shall be identified in accordance with Section 35, Polarization and Identification.

31.5 Integral Type SP-1, SPT-1, or SPE-1 flexible cord or appliance wiring material in accordance with Figure 27.1, that is located inside a portable luminaire is able to split a maximum of 3 inches (76 mm).

Exception No. 1: The flexible cord is able to be split more than 3 inches when each conductor is enclosed in supplementary insulation for the temperature involved.

Exception No. 2: The flexible cord located within a portable luminaire is able to be split more than 3 inches when the cord is Integral Type SP-2, SPE-2, or SPT-2.

31.6 Flexible cord types C, HPN, PD, SP-1, SPE-1, SPT-1, and appliance wiring material complying with Figure 27.1 are usable only as internal wiring and shall not be used as power supply cord.

32 Attachment Plugs

32.1 A portable luminaire shall be provided with a polarized attachment plug of the 2-wire, parallel-blade or a 3-wire grounded type and see Figure 32.1. The plug shall be of a 15 ampere, 125 volt configuration (NEMA Style Nos. 1-15 P and 5-15P) and shall comply with the requirements in the Standard for Attachment Plugs and Receptacles, UL 498 and/or the Standard for Cord Sets and Power-Supply Cords, UL 817.

Exception: An attachment plug in accordance with Alternate Power-Supply Connections, Section 34, is not required to comply with the requirement.

Figure 32.1
Connections to attachment plug

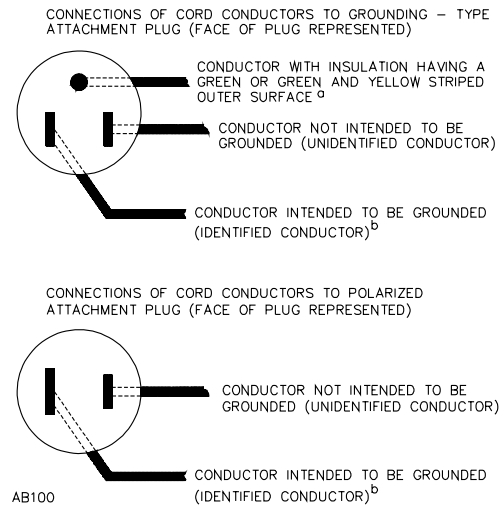

^a In the above illustration, the blade to which the green conductor is connected may have a U-shaped or a circular cross section.

^b Signifies a conductor identified in accordance with Table 35.1.

32.2 The attachment plug shall have electrical ratings as required for the ratings of the portable luminaire. See Electrical Ratings, Section 26.

32.3 For an attachment plug that is assembled to a flexible cord by a manufacturer of the portable luminaire the conductors of the flexible cord shall be fastened securely and in a workmanlike manner to the terminals of the attachment plug. All connections shall be made so that no stray strands of any conductor contacts live parts of opposite polarity or dead metal parts.

32.4 When the intended mounting means of a portable luminaire precludes factory connection of the attachment plug to the flexible cord, a pin-type (screwless) polarized attachment plug (one in which a pin terminal pierces the conductor insulation to establish contact) is able to be provided. Instructions shall be provided in accordance with 183.5.

33 Interconnected Units

33.1 Only portable luminaires for use in cabinets, under cabinets (under shelves), office furnishings, work lights, and wet location luminaires, are able to be equipped such that one unit provides power for adjacent units.

33.2 When the supplementary requirements elsewhere in the Standard specify overcurrent protection for the power supply cord, the protection shall either be a circuit breaker or a replaceable fuse.

33.3 Interconnected units that do not have a NEMA Style 1 and 15, 1 and 15P, 5 and 15 or 5 and 15P plug and are intended to connect to a unit which has overcurrent protection, do not require overcurrent protection.

33.4 Interconnected units, where a ballast or transformer of one portable luminaire powers one or more adjacent units, do not require overcurrent protection. The plugs, receptacles, and cord shall have a rating consistent with the voltage and the load.

33.5 A fuseholder shall be of the lock out type and prevent insertion of a fuse larger than that specified by the manufacturer.

33.6 The ground connection when required by Grounding and Bonding, Section 36, shall make first and break last.

33.7 An interconnected unit shall be provided with markings in accordance with 169.9.

33.8 An interconnected unit shall be provided with instructions in accordance with 183.4.

33.9 An interconnected unit with a shortened power supply cord in accordance with 34.3 shall be marked in accordance with 169.9.1 and instructions in accordance with 183.6.

34 Alternate Power-Supply Connections

34.1 For a portable luminaire that is intended to be used in countries other than the United States, the configuration of the attachment plug shall conform with the standards of the country in which the product is intended to be used and shall be provided with instructions in accordance with 183.8.

34.2 A proprietary connector provided in place of an attachment plug or an attachment plug and cord shall be investigated and determined usable for the purpose for which it is intended and shall be provided with markings and instructions in accordance with 183.7.

34.3 When the intended means of mounting or other features or constructions of any portable luminaire warrants other than the required length of power supply cord, a shorter cord (or no cord) is able to be provided. Instructions shall be provided in accordance with 183.6.

35 Polarization and Identification

35.1 A supply-circuit conductor that is connected to the grounded supply conductor (neutral) shall be marked in accordance with Table 35.1 and shall be connected to the wide blade of a 2-wire attachment plug, or the left-hand blade of a 3-wire attachment plug when looking at the face of the plug with the grounding pin up. See Figure 32.1.

Exception: A Class 2 low voltage plug-in transformer is not required to be provided with a polarized type 2-wire attachment plug.

**Table 35.1
Polarity identification of flexible cords**

Method of identification	Color combinations	
	Wire intended to be grounded ^e – connected to the screw shell of lampholders	All other wires ^e
Color of braids on individual conductors	Solid white or natural gray – without tracer Solid white or natural gray – without tracer ^a Color other than white or natural gray, with tracer in braid	Solid color other than white or natural gray – without tracer White or natural gray with tracer in braid ^a
Color of insulation on individual conductors	Solid white, natural gray, or blue ^b	Solid color other than white or natural gray – without tracer Solid color other than white, natural gray, or blue ^b
Color of separators	White or natural gray ^c Tin or other white metal on all strands of the conductor ^d	Color other than white or natural gray ^c No tin or other white metal on the strands of the conductor ^d
Other means	A stripe, ridge, or groove on the exterior surface of the cord ^c	
^a Only for Types C and PD cords. ^b Only for cords – other than Types SP-1, SP-2, SPE-1, SPE-2, SPT-1, and SPT-2 cords and AWM complying with Figure 27.1 – having no braid on any individual conductor. ^c Only for Types SP-1, SP-2, SPE-1, SPE-2, SPT-1, and SPT-2 cords, and AWM complying with Figure 27.1. ^d Only for Types SPT-1 and SPT-2 cords and AWM complying with Figure 27.1. ^e A wire finished to show a green color with or without one or more yellow stripes or tracers shall be used only as an equipment-grounding conductor. See Figure 32.1.		

35.2 The screwshell or screwshell contact of each Edison-base lampholder shall be connected to the grounded supply conductor of the supply cord.

35.3 A switch or a fuse or other protective device shall not be connected to the grounded supply conductor of the attachment plug.

Exception: When the switch or protective device simultaneously interrupts both conductors of the supply circuit, it is able to be connected to the grounded supply conductor.

35.4 Any portion of a portable luminaire that is capable of being detached thereby breaking electrical connections – such as a detachable power-supply cord, interlocking connectors, or cord connector– shall be constructed such that it is only able to be assembled in the manner which is required to maintain polarity.

36 Grounding and Bonding

36.1 When a 3-conductor cord-and-plug assembly is provided on a portable luminaire, all conductive parts of a portable luminaire not intended to be electrically live, that are accessible to persons including during any user maintenance and that have the potential to inadvertently become energized shall be grounded by being conductively bonded together to the equipment grounding means.

Exception: Chain links of a swag type unit are not required to be bonded.

36.2 When the reliability of a grounding connection is questioned, it shall be subjected to the Grounding Continuity Test, Section 136.

36.3 A part is determined to be accessible when it is capable of being touched by the probe illustrated in Figure 23.1.

36.4 A conductive part that is required to be grounded or bonded in accordance with 36.1 shall not be coated with vitreous enamel, paint, or similar coating.

Exception No. 1: The surface is able to be coated when it is marked or treated such that there is bare metal contact at the point(s) of bonding.

Exception No. 2: The surface is able to be coated when the means of bonding reliably penetrates or scratches the surface such that there is bare metal contact at the point(s) of bonding.

36.5 The continuity of the grounding or bonding system shall not rely on solder alone or on the dimensional integrity of a thermoplastic material.

Exception: When a material complies with the applicable requirements for Polymeric Decorative Parts, Section 13, and Polymeric Enclosure, Section 12, its integrity is determined reliable for continuity of the grounding or bonding system.

36.6 The grounding terminal of a convenience receptacle provided on a portable luminaire with a metal enclosure shall be bonded to the grounded metal of the unit by one of the following:

- a) Riveting, bolting, or welding the metal mounting yoke or strap, when provided, of the receptacle to the metal unit enclosure.
- b) A No. 16 AWG (1.3 mm²) or larger copper bonding jumper from the receptacle grounding terminal to the unit enclosure, the connection to the lamp enclosure being made by riveting, bolting, or welding.

36.7 A bonding or grounding wire or jumper connector shall be secured by:

- a) A machine screw and nut;
- b) A machine screw that threads into metal when there are at least two full threads in the metal; or
- c) A rivet.

A sheet-metal screw shall not be used to secure a bonding or grounding wire or jumper connector.

36.8 A bonding or grounding wire or jumper connector shall not be terminated by a screw, rivet, or equivalent device that is also used to secure another device or part that is intended to be removed during replacement of any electrical device or component other than the power-supply cord.

37 Electronic Circuits

37.1 A printed wiring board, including coatings, when provided shall comply with the requirements in the Standard for Printed-Wiring Boards, UL 796, and shall be classified V-0, V-1, or V-2 in accordance with the Standard for Tests for Flammability of Plastic Materials for Parts in Devices and Appliances, UL 94.

Exception: A printed wiring board containing only circuitry not exceeding Class 2 limits is not required to comply with this requirement.

37.2 A resistor, capacitor, inductor, transformer, or other part that is mounted on a printed wiring board to form a printed-wiring assembly shall be secured so that the risk of displacement by any force exerted on it is minimized.

37.3 A circuit involving a capacitor, rectifier, transistor, or similar component is to be subjected to analysis to determine whether there is a risk of fire or electric shock when the component is opened or shorted. The possible effect of one component on another, encapsulation, and similar factors are to be determined. When a risk is determined to exist, the Component Fault Test, Section 131 is to be conducted.

38 Secondary Low Voltage Circuits

38.1 Each secondary circuit exceeding Class 2 limits shall be investigated as though it were a primary circuit with respect to enclosure and accessibility requirements.

Exception: Isolated low-voltage circuits not exceeding 30 volts rms are not required to comply with the accessibility requirements of Accessibility of Live Parts, Section 23.

38.2 The enclosure and accessibility of a Class 2 circuit is not specified.

38.3 A printed wiring assembly and subsequent circuitry used in an isolated, low-voltage circuit exceeding Class 2 limits shall comply with the requirements of Electronic Circuits, Section 37.

38.4 An isolated, low-voltage circuit is able to use the frame of the portable luminaire to carry current to one side of the load when hinges or other moveable parts are not used as current-carrying means.

Exception No. 1: A hinge or other moveable part is to be used as a current-carrying means when it complies with the test requirements in Low Voltage Hinged or Moveable Part Cycling Test, Section 139.

Exception No. 2: A Class 2 circuit is able to use the frame of the portable luminaire to carry current to one or both sides of the load, and to use a hinge or other moveable part as a current-carrying means.

39 Separation of Secondary Circuit Conductors

39.1 All uninsulated live parts connected to different circuits shall be spaced from one another as though they were parts of opposite polarity, in accordance with the requirements in 24.1 and shall be judged on the basis of the highest voltage involved.

39.2 The wiring in an isolated, low-voltage circuit shall be routed away from the wiring of primary circuits or shall be provided with insulation that is rated for use at the highest of the voltages in the circuits.

39.3 Wires that are part of an isolated low-voltage circuit shall be maintained away from uninsulated live parts of the primary circuit.

40 Component Mounting

40.1 Uninsulated live parts shall be secured to the base or mounting surface so that they are restrained from turning or shifting in position, when such motion results in a reduction of spacing below the minimum required value.

40.2 A joint between metal parts or between fastening arms and supports, shall be strong and rigid and shall not turn when such turning results in movement of a wire or a wiring device after the assembly is completed.

40.3 A switch other than a through-cord switch, a ballast other than a through-cord ballast, a lampholder, convenience receptacle, an attachment-plug receptacle, or similar component shall be mounted securely and shall be restrained from turning.

Exception No. 1: A switch is not required to be restrained from turning when all four of the following conditions are met:

- a) The switch is of a plunger or other type that does not tend to rotate when operated. A toggle switch is determined to be subject to forces that tend to turn the switch during normal operation of the switch.*
- b) The means for mounting the switch prevents the operation of the switch from loosening it.*
- c) The spacing are not reduced below the minimum required values when the switch rotates.*
- d) The normal operation of the switch is by mechanical means rather than by direct contact by persons.*

Exception No. 2: A lampholder of the type in which the lamp is unable to be replaced, such as a neon pilot or indicator light in which the lamp is sealed in a nonremovable jewel, is not required to be restrained from turning when rotation does not reduce spacing below the minimum required values.

Exception No. 3: A lampholder is not required to be restrained from turning when:

- a) The means of providing strain relief is not affected by the rotation of the lampholder; and*
- b) The cord or wiring is not twisted by the rotation (turns freely during rotation).*

40.4 The means for preventing the turning or shifting indicated in this section is to consist of more than friction between surfaces. For example:

- a) A properly applied lock washer that "cuts" into the surfaces it is placed between;
- b) An irregularly shaped opening that prevents rotation by physical fit;
- c) A tab that contacts another tab or obstruction that prevents further rotation; or
- d) A set screw.

Exception No. 1: A candelabra-base lampholder held in a spring-clip bracket is able to be prevented from rotating by the friction pressure of the spring clip against the mounting surface.

Exception No. 2: The fastening means for securing telescoping parts in an adjustable telescoping arm friction alone is usable when rotation between parts is limited to 360 degrees or less and rotation does not result in damage to conductor insulation.

40.5 A sheet-metal or self-threading screw is able to be used to secure or support a part, such as a ballast, transformer, lampholder, starter holder, or a similar component, that weighs more than 7-1/2 pounds (3.4 kg), to a sheet steel luminaire part. A sheet-metal or self-threading screw in accordance with Security of Screws Test, Section 135, is not prohibited from securing or supporting a part, such as a ballast, transformer, lampholder, starter holder, or a similar component to other than a sheet steel luminaire part.

41 Lampholders

41.1 General

41.1.1 A lampholder with exposed terminals shall have the terminals located behind a permanent barrier or similar construction to comply with the requirements for Enclosures, Section 9, and the requirements for Accessibility of Live Parts, Section 23.

41.1.2 A lamp-supported lampholder shall be provided with stranded wiring.

41.2 Incandescent lampholders

41.2.1 A lampholder, constructed with exposed terminals, that is intended to be provided with a fiber husk and/or outer sleeve (thereby resembling a candle) to prevent inadvertent contact of the terminals shall not be used in a portable luminaire unless evaluated for compliance with 41.2.2 or 41.2.3, as applicable.

Exception: The lampholder is able to be used when live parts are not accessible, as specified in Accessibility of Live Parts, Section 23, when the outer sleeve or outer husk is removed.

41.2.2 The use of a thermoplastic sleeve:

- a) Complying with the Polymeric Decorative Parts, Section 13, and Polymeric Enclosure, Section 12, requirements;
- b) Secured in place; and
- c) Not removable without the use of tools;

Meets the intent of the requirement when, with the sleeve in place, the construction complies with the accessibility requirements in Accessibility of Live Parts, Section 23. See 41.2.1.

41.2.3 The use of a fiber husk:

- a) Complying with the 1/32 inch (0.8 mm) minimum treated cellulosic fiber for the fiber husk;
- b) Secured in place; and
- c) Not removable without the use of tools;

Meets the intent of the requirement when, with the sleeve in place, the construction complies with the accessibility requirements in Accessibility of Live Parts, Section 23. See 41.2.1

41.2.4 A porcelain lampholder mounted by means of a screw ring shall be used only with the gasket usually supplied with this type of lampholder.

Exception: The gasket is not required when a lampholder is mounted on and supported by porcelain.

41.2.5 A lampholder of the 3-way switch type shall be installed in only the base down position.

42 Switches and Dimmers

42.1 A switch provided for the control of a portable luminaire shall have a current rating for the load it controls in accordance with Figure 42.1.

Figure 42.1
Switch ratings

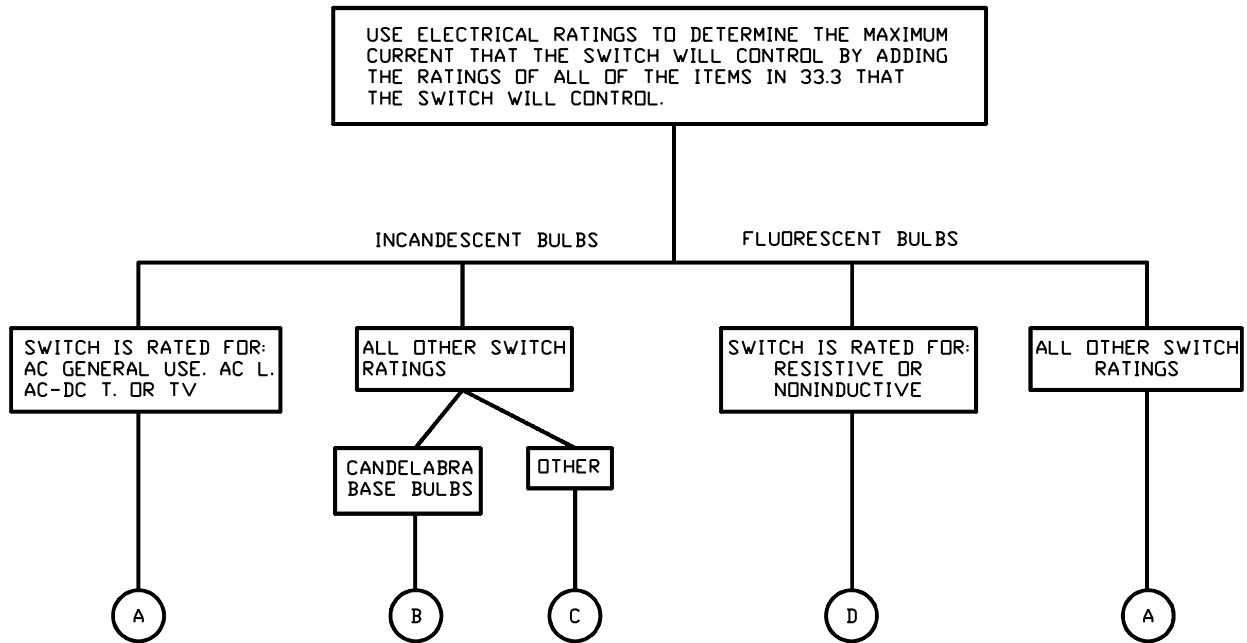

S3382A

- a) The switch shall be rated for at least the current it is to control. The current rating for a TV rated switch is indicated as a suffix, for example, TV5 has a 5 ampere rating.
- b) The switch shall be rated for at least five times the current it is to control (that is, when it controls a maximum 0.5 ampere load, it shall be rated for minimum 2.5 amperes).
- c) The switch shall be rated for at least six times the current it is to control (that is, when it controls a maximum 0.5 ampere load, it shall be rated for minimum 3.0 amperes).
- d) The switch shall be rated for at least two times the current it is to control (that is, when it controls a maximum 0.5 ampere load, it shall be rated for minimum 1.0 ampere).

42.2 A switch shall not be connected in the load side of a ballast.

Exception: A switch is able to be connected in the load side of a reactor ballast.

42.3 A portable luminaire is not required to be provided with a switch.

42.4 A switch provided for the control of a motor load shall be investigated to determine that it is intended for the purpose.

43 Receptacles

43.1 A convenience receptacle provided on a portable luminaire shall be of the same type and configuration as the attachment plug of the unit, and shall be wired such that it provides the same polarized supply as the attachment plug of the unit. See Figure 32.1.

43.2 A portable luminaire shall not be provided with more than two single or one duplex receptacle. The electrical rating shall be marked in accordance with 169.6.3.

43.3 When the face of a receptacle is less than 5/8 inch (15.9 mm) wide or less than 7/8 inch (22.2 mm) long, the face of the receptacle shall project not more than 3/16 inch (4.8 mm) from the part of the mounting surface that is within a rectangle 7/8 inch (15.9 mm) long and 5/8 inch (15.9 mm) wide symmetrically located about the receptacle contacts; and when the mounting surface is conductive, the face of the receptacle shall project not less than 3/32 inch (2.4 mm) from that part of the mounting surface.

43.4 The area surrounding a convenience receptacle shall be free of any projection that prevents full insertion of the blades of an attachment plug having a face diameter of 1-15/16 inches (49.2 mm) and rectangular attachment plug having a face of 1-1/2 by 1-5/8 inch (38.1 by 41.3 mm).

Exception: Projections that prevent the blades of the attachment plug from making electrical contact with the female contacts of the receptacle meet the intent of the requirement.

44 Transformers

44.1 Transformers used in portable luminaires shall be subjected to the Transformer Voltage Output Test, Section 138, and Transformer Short-Circuited Test, Section 130, or shall comply with the requirements in one of the following standards:

- a) Standard for Class 2 Power Units, UL 1310;
- b) Standard for Transformers and Motor Transformers for Use In Audio-, Radio-, and Television-Type Appliances, UL 1411; or
- c) Standard for Class 2 and Class 3 Transformers, UL 1585.

Exception: A transformer used in a portable luminaire that provides the enclosure required by Enclosures, Section 9 is not required to have a separate enclosure.

45 Motors

45.1 Each motor shall be of a type that is intended for its application and shall operate at its maximum normal load during the Normal Temperature Test, Sections 124 – 128, without resulting in a risk of fire, electric shock, or injury to persons.

45.2 A motor winding shall resist the absorption of moisture.

45.3 Each motor shall be protected from overheating as the result of any condition of load, up to and including stalled rotor.

45.4 The protection against overheating required by 45.3 shall be accomplished by one of the following:

- a) Thermal impedance protection complying with the requirements in the Standard for Overheating Protection for Motors, UL 2111; or
- b) Other protection that is found by test to be equivalent to the protection specified in (a).

INCANDESCENT UNITS – SUPPLEMENTARY

46 General

46.1 The requirements specified in Sections 46 – 50 apply to portable luminaires using incandescent lamps.

46.2 These requirements do not apply to portable luminaires intended for use with tungsten-halogen lamps which are covered by Sections 51 – 56.

Exception: Double enveloped, tungsten-halogen lamps similar in shape to a Type A incandescent lamp, rated 100 watts or less, complying with the requirements of 54.1.2, are able to be evaluated to the Temperature Test-Exempt Units requirements of Section 47.

46.3 These requirements are supplementary to other applicable requirements in this Standard.

47 Temperature Test-Exempt Units

47.1 General

47.1.1 An incandescent portable luminaire that complies with the requirements of this section is not required to be subjected to the Normal Temperature Tests of Section 124, General, and Section 125, Test Method – General.

47.1.2 A unit that incorporates the following additional features is not temperature test exempt:

- a) Employs a transformer, motor or similar electrical component that is able to generate heat;
- b) Employs polymeric materials used as an enclosure, barrier, structural part, or water shield;
- c) Employs a closed shade with total lamp wattage greater than 7 W;
- d) Employs a shade or decorative part of a material that is able to melt or deform in such a way as to interfere with the normal operation of the lamp; or

- e) Is intended for installation in or under a cabinet.
- f) Employs a metal shell type medium base lampholder in the base-up position.

47.2 Determination of temperature test-exempt status

47.2.1 The following steps are to be followed to determine when a portable luminaire complies with the temperature test exempt requirements:

- a) Determine shade designation in accordance with 47.3;
- b) Determine minimum lamp-to-shade spacings for shade designation, lampholder type and wattage in accordance with 47.4; and
- c) Determine minimum wire insulation temperature rating in accordance with 47.5.

47.2.2 A portable luminaire is temperature test exempt when it complies with all the requirements of 47.2.1.

47.2.3 Portable luminaires with shade designs meeting the requirements of 47.6 are temperature test exempt.

47.3 Shade designation

47.3.1 The shade designation required in 47.2.1(a) is to be assigned by determining when there are shade openings above and below the lamp, and when the opening size complies with the minimum area specified in Table 47.1 for the designation. Also see Figure 47.1 for examples.

Table 47.1
Shade opening size for "open" designations

Maximum marked lamp wattage ^a	Minimum opening area		Minimum opening diameter	
	in ²	(cm ²)	in ²	(cm ²)
25	7	(45)	3	(19)
75	10	(65)	3.5	(23)
100	13	(84)	4	(26)
150	16	(103)	4.5	(29)
200	20	(129)	5	(32)
250	24	(155)	5.5	(35)
300	29	(187)	6	(39)

^a For a shade with more than one lamp, the lamp wattage is the sum of all lamp wattages. When the marked lamp wattage (or for multiple lamps, the sum of all lamp wattages) is between the value specified, the minimum opening area shall be that for the next highest wattage.

^b Dimensions specified apply to a circular shade openings corresponding to the minimum opening area specified in column two. For a non-circular opening, the maximum linear dimension may be greater providing the opening area complies with the value specified in column two.

Figure 47.1
Shade configuration

OPEN TOP/OPEN BOTTOM

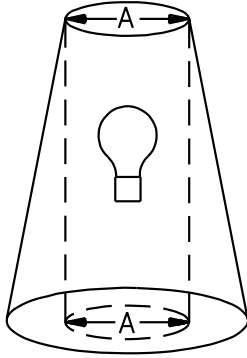

OPEN TOP/CLOSED BOTTOM

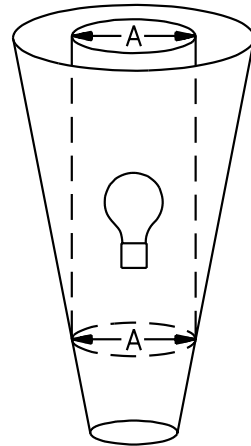

CLOSED TOP/OPEN BOTTOM

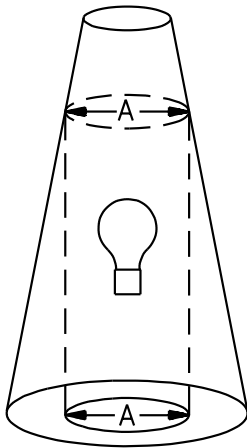

CLOSED TOP/CLOSED BOTTOM

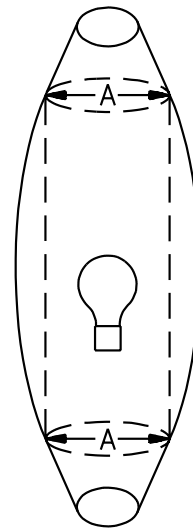

S4382

Dimension "A" is the minimum opening area specified in Table 47.1 shade opening size for "open" designations.

47.3.2 The assigned shade designations are:

OPEN TOP / OPEN BOTTOM – A shade has this designation when an opening exists above and below the lamp of the minimum size specified in Table 47.1.

OPEN TOP / CLOSED BOTTOM – A shade has this designation when an opening exists above the lamp of the minimum size specified in Table 47.1. Any opening below the lamp is smaller than that required for the shade to qualify as Open Top / Open Bottom.

CLOSED TOP / OPEN BOTTOM – A shade has this designation when an opening exists below the lamp of the minimum size specified in Table 47.1. Any opening that exists above the lamp is smaller than that required to qualify as Open Top / Open Bottom.

CLOSED TOP / CLOSED BOTTOM – A shade has this designation if when the openings above and below the lamp are smaller than the minimum size specified in Table 47.1. The maximum marked lamp wattage is 7 watts.

47.3.3 Any obstructions to an opening in the shade, including 4 inches (101.6 mm) above and below dimension A in Figure 47.1 for open designations, must be deducted from the area calculation to determine compliance with Table 47.1. The lamp itself, the lampholder (or a maximum 1/2 inch diameter nipple or rod to support the lampholder), or a simple harp or wire to support the shade are not identified as obstructions.

47.3.4 A shade with an obstruction meets the intent of the requirement when the remaining unobstructed area is at least 10 percent greater than the amount required for an otherwise unobstructed shade.

47.4 Lamp-to-shade spacing

47.4.1 Lamp-to-shade spacing required in 47.2.1(b) is to be determined by measuring the minimum distance from any point on the lamp centerline to the nearest point on a shade in accordance with Table 47.2 – Open Top/Open Bottom, Table 47.3 – Open Top/Closed Bottom, or Table 47.4 – Closed Top/Open Bottom, as applicable. See Figure 47.2 for an example of lamp-to-shade spacing measurement.

Table 47.2
Open top / open bottom shade minimum lamp-to-shade spacing

Lampholder type	Marked lamp wattage ^a	Lamp centerline length		Minimum lamp-to-shade spacing	
		Inch	(mm) ^b	Inch	(mm) ^c
Medium	25	2-3/4	(69.8)	1-5/8	(41.2)
	40	3-1/4	(82.5)	2	(50.8)
	60	3-1/4	(82.5)	2-1/2	(63.5)
	75	3-1/4	(82.5)	2-7/8	(73)
	100	3-1/4	(82.5)	3-1/2	(88.9)
	150	3-1/4	(82.5)	4-3/4	(120.6)
	200	3-7/8	(98.4)	6	(152.4)
	250	4-1/2	(114.3)	7-1/4	(184.4)
Intermediate	300	5	(127)	8-1/2	(215.9)
	20	1-3/4	(44.4)	1-1/2	(38.1)
Candelabra	40	2	(50.8)	2	(50.8)
	25	2	(50.8)	1-5/8	(41.2)
	40	2	(50.8)	2	(50.8)

Table 47.2 Continued on Next Page

Table 47.2 Continued

Lampholder type	Marked lamp wattage ^a	Lamp centerline length		Minimum lamp-to-shade spacing	
		Inch	(mm) ^b	Inch	(mm) ^c
	60	2	(50.8)	2-1/2	(63.5)

^a For a shade with more than one lamp, the minimum spacing is to be measured from each lamp.
^b See 47.4.4.
^c See 47.4.1.

Table 47.3
Open top / closed bottom shade minimum lamp-to-shade spacing

Lampholder type	Marked lamp wattage ^a	Lamp centerline length ^b		Minimum lamp-to-shade spacing ^c	
		inch	(mm)	inch	(mm)
Medium	25	2-3/4	(69.8)	2-1/8	(53.9)
	40	3-1/4	(82.5)	2-1/2	(63.5)
	60	3-1/4	(82.5)	3	(76.2)
	75	3-1/4	(82.5)	3-3/8	(85.7)
	100	3-1/4	(82.5)	4	(101.6)
	150	3-1/4	(82.5)	5-1/4	(133.3)
	200	3-7/8	(98.4)	6-1/2	(165.1)
	250	4-1/2	(114.3)	7-3/4	(196.8)
Intermediate	300	5	(127)	9	(228.6)
	20	1-3/4	(44.4)	2	(50.8)
Candelabra	40	2	(50.8)	2-1/2	(63.5)
	25	2	(50.8)	2-1/8	(53.9)
	40	2	(50.8)	2-1/2	(63.5)
	60	2	(50.8)	3	(76.2)

^a When more than one lamp in shade, the minimum spacing is to be measured from each lamp.
^b See 47.4.4.
^c See 47.4.1.

Table 47.4
Closed top / open bottom shade minimum lamp-to-shade spacing

Lampholder type	Marked lamp wattage ^a	Lamp centerline length ^b		Minimum shade height ^c		Minimum lamp-to shade spacing ^d	
		inch	(mm)	inch	(mm)	inch	(mm)
Medium	25	2-3/4	(69.8)	2-1/2	(63.5)	3	(76.2)
				1-1/2	(38.1)	4	(101.6)
				12	(304.8)	4	(101.6)
	40	3-1/4	(82.5)	6	(152.4)	5	(127)
				5	(127)	6	(152.4)
				3-1/2	(127)	7	(177.8)
				13	(330.2)	5	(127)
				8-1/2	(215.9)	6	(152.4)
				5-1/2	(139.7)	7	(177.8)
	60	3-1/4	(82.5)	11	(279.4)	6	(152.4)
				8-1/2	(215.9)	7	(177.8)
				5-1/2	(139.7)	7	(177.8)
75	3-1/4	(82.5)	8-1/2	(215.9)	7	(177.8)	
			7	(177.8)	8	(203.2)	

Table 47.4 Continued on Next Page

Table 47.4 Continued

Lampholder type	Marked lamp wattage ^a	Lamp centerline length ^b		Minimum shade height ^c		Minimum lamp-to shade spacing ^d	
		inch	(mm)	inch	(mm)	inch	(mm)
	100	3-1/4	(82.5)	10 9-1/2 8	(254) (241.3) (203.2)	7 8 9	(177.8) (203.2) (228.6)
	150	3-1/4	(82.5)	10-1/2	(266.7)	9	(228.6)
Intermediate	20	1-3/4	(44.4)	5-1/2	(139.7)	2	(50.8)
				2	(50.8)	3	(76.2)
				1-1/2	(38.1)	4	(101.6)
	40	2	(50.8)	1	(25.4)	5	(127)
				11	(279.4)	5	(127)
				8-1/2	(215.9)	6	(152.4)
			6-1/2	(165.1)	7	(177.8)	
Candelabra	25	2	(50.8)	6-3/4	(171.4)	2	(50.8)
				5-3/4	(146)	3	(76.2)
				4-3/4	(120.6)	4	(101.6)
				1-3/4	(44.4)	5	(127)
	40	2	(50.8)	10	(254)	4	(101.6)
				7	(177.8)	5	(127)
				5-1/2	(139.7)	6	(152.4)
	60	2	(50.8)	4-1/2	(114.3)	7	(177.8)
				9-3/4	(247.6)	6	(152.4)

^a When more than one lamp in shade, the minimum spacing and height is to be measured from each lamp.
^b See 47.4.4.
^c See 47.4.5.
^d See 47.4.1.

Figure 47.2
Minimum lamp-to-shade spacings

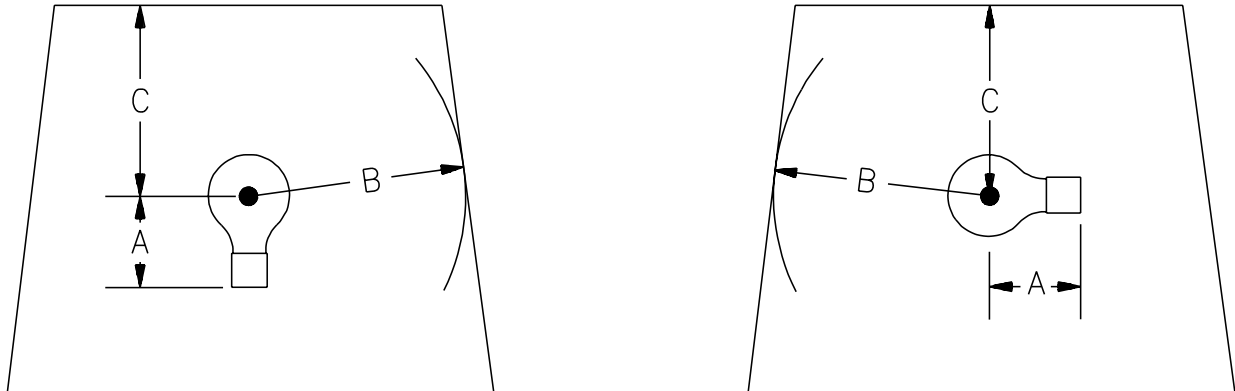

S4381

Dimension "A" is the lamp centerline length, and dimension "B" is the minimum lamp-to-shade spacing. Dimension "C" is the minimum shade height for closed top/open bottom only measured for the highest elevation point along the lamp centerline to the shade. See 47.4.

47.4.2 The lamp-to-shade spacing shall be evaluated with the shade in the position that results in minimum spacings unless the shade is constructed such that it is not able to be repositioned. A shade supported by a harp or one that clips on to a lamp is determined to be adjustable.

Exception No. 1: A shade made of metal, glass, or porcelain is evaluated in only the normal use position.

Exception No. 2: A shade that has been determined to be ignition resistant in accordance with Lamp Shade Ease of Ignition Test, Section 140, and also been evaluated for flame resistance in accordance with the Standard for Flame Propagation of Fabrics and Films, UL 214, is evaluated only in the normal use position.

Exception No. 3: A shade that is secured by a lamp harp that is fixed by welding, brazing, or by mechanical means is not required to comply with the above requirement. Shades supported by harps complying with the Lamp Harp Torque Test in Section 139 are evaluated in only the normal use position. Adhesives or sealants shall be evaluated for compliance with the adhesive requirements for the Standard for Polymeric Materials – Use In Electrical Equipment Evaluations, UL 746C.

Exception No. 4: A portable luminaire for use with a lamp rated 150 W or less that is provided with a shade that is adjustable and that complies with the minimum lamp-to-shade spacings in the normal use position for a 150 W rated lamp as specified in the requirements for Temperature Test Exempt Units, Section 47, is evaluated in only the normal use position.

47.4.3 The minimum lamp-to-shade spacing for a Closed shade (maximum 7 W) is 1 inch in any direction from any point on the lamp centerline, where the lamp centerline is 2 inches (50.8 mm) maximum.

47.4.4 The lamp centerline is a straight line extending out perpendicularly from the depressed center contact of the lampholder for the distance specified in Tables 47.2 – 47.4.

47.4.5 The minimum shade height for an Closed Top/Open Bottom shade (Table 47.4) is the vertical distance measured from the highest elevation point along the lamp centerline to the shade. Lampholder orientation (up, down, horizontal, etc.) affects this measurement. No obstructions are to exist within this distance.

47.5 Wire insulation temperature rating

47.5.1 The minimum wire insulation temperature rating required in 47.2.1(c) shall be:

- a) 60°C when spaced greater than 2 inches from any incandescent lamp or lampholder; and
- b) In accordance with Table 47.5 when spaced within 2 inches of any incandescent lamp or lampholder.

Table 47.5
Wire insulation temperature rating

Shade type	Lampholder orientation ^a	Minimum wire rating, °C
Open Top/Open Bottom, or Open Top/ Closed Bottom	down	75 ^b
	up	105
Closed Top/Open Bottom	down	105
	up	150
Closed Top/Closed Bottom ^c	any	105
^a Down – lampholder below the horizontal plane of the filament Up – lampholder at or above the horizontal plane of the filament ^b 60°C for marked lamp wattage of 100 W or less ^c Maximum 7 W marked lamp wattage.		

47.6 Other shade designs

47.6.1 A portable luminaire is able to use a shade other than those specified by 47.3 – 47.5 and be temperature test exempt, when the unit has:

- a) A glass chimney that follows the contours of the lamp and is used to direct heat upward;
- b) A shade is provided and is spaced a minimum of 1/2 inch (12.7 mm) from the chimney on all sides. The shade extends from the bottom of the chimney to at least one lamp height above the lamp, and has a top opening through which the chimney extends; and
- c) The wiring to the lampholder is rated 105°C minimum.

47.6.2 The shade in 47.6.1(b) is not required when the unit is rated for maximum 60 W lamp replacement.

48 Tests

48.1 Normal temperature test

48.1.1 An incandescent type unit shall be temperature tested in accordance with the Normal Temperature Test, Section 124, General, and Section 125, Test Method – General, except as exempted by Section 47, Temperature Test-Exempt Units.

49 Markings

49.1 An incandescent type unit shall comply with the marking specified in Section 170, Incandescent Units.

50 Instructions

50.1 An incandescent type unit shall comply with the instructions specified in Section 184, Incandescent Units.

TUNGSTEN HALOGEN UNITS – SUPPLEMENTARY

51 General

51.1 The requirements specified in Sections 51 – 56 apply to portable luminaires using tungsten-halogen type lamps.

51.2 These requirements are supplementary to other applicable requirements in this standard.

52 Construction – Mechanical

52.1 General

52.1.1 Tungsten-halogen units utilizing lamps that are directly connected to a branch circuit (without the use of a low-voltage transformer), shall not utilize single-ended bi-pin lamps with bases that are restricted to low-voltage use only. Examples of single-ended bi-pin lamp bases that are restricted to low-voltage use only are: G4, GU4, GX5.3, GU5.3, G6.35, GY6.35, and GU7.

52.1.2 A guard, lamp containment barrier, and UV filter is able to be fabricated as a single part.

52.1.3 A guard, lamp containment barrier, or UV filter shall be secured in position by:

- a) A mechanical means that produces an interference fit;
- b) A twist and lock means;
- c) Spring clips; or
- d) Other mechanical means.

52.1.4 An adhesive used to secure a guard, lamp containment barrier, or UV filter shall be investigated in accordance with the Standard for Polymeric Materials – Use in Electrical Equipment Evaluations, UL 746C.

52.1.5 Any part required for compliance with the Tungsten Halogen Lamp Adjacent Surfaces and Overlamping Abnormal Operation Test of Section 143, including guards, lamp containment barriers, UV filters, and spacers or similar projections, shall be factory installed and require the use of a tool for removal.

Exception No. 1: A guard for a work light may be shipped unattached in accordance with 114.1.2.

Exception No. 2: A guard for a work light may be attached without the use of tools when it complies with 114.2.5

52.1.6 A tungsten-halogen torchiere style floor unit that complies with the Heat Flux Density Measurement Test specified in Section 152 shall be shipped from the factory with the tungsten-halogen lamp of the type and wattage for which the unit is designed and rated.

52.2 Guard

52.2.1 A tungsten-halogen type unit shall be provided with a lamp compartment or a guard such that the lamp is inaccessible to inadvertent contact during normal use (see 52.2.2). The evaluation is done for each position that is attainable by an adjustment means.

Exception: A portable luminaire intended for use with a single-ended tungsten-halogen lamp with an integral outer envelope for which the lamp manufacturer does not require a guard or lamp containment barrier is not required to be provided with a guard when the unit is marked in accordance with 171.2.2 or 171.2.4.

52.2.2 With respect to 52.2.1, a lamp is determined to be inaccessible to inadvertent contact when a 1-1/2 inch (38 mm) diameter probe of any convenient length with a 3/4 inch (19 mm) radius rounded (hemispherical) end (see Figure 52.1) is unable to be made to contact any part of the lamp with the guard in place as intended. The probe is to be rotated or angled to any position before, during, or after insertion into an opening, and the penetration is to be to any depth attainable by the opening.

Exception No. 1: A floor type unit with a single lamp at least 5 feet (1.5 m) above the floor in its lowest position is required to only have the lamp inaccessible, as determined by the probe, from underneath or from the sides of the unit.

Exception No. 2: A surface-mount unit:

a) With a single lamp; and

b) Marked in accordance with 171.4 to indicate mounting a minimum of 5 feet above the floor is required to only have the lamp inaccessible, as determined by the probe, from underneath or from the sides of the unit.

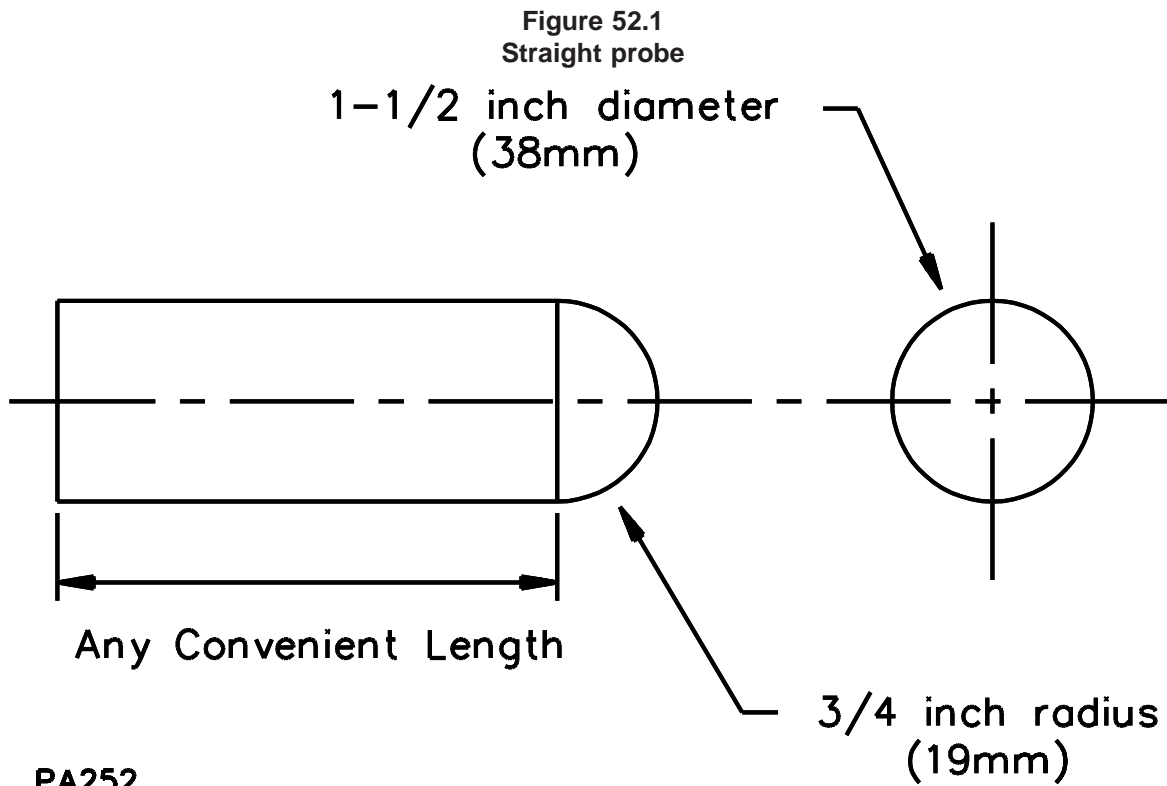

PA252

52.2.3 A guard shall be constructed of:

- a) Metal, minimum 0.016 inch (0.41 mm) thick;
- b) Heat resistant glass such as tempered, annealed or borosilicate glass;
 - 1) Minimum 1/8 inch (3.2 mm) (3.0 mm metric trade size) thick when used with lamps rated 100 W or greater; or
 - 2) Minimum 3/32 inch (2.4 mm) thick when used with lamps rated less than 100 W;
- c) Porcelain or ceramic; or
- d) A polymeric material, minimum 3/32 inch (2.4 mm) thick.

52.2.4 A guard constructed of a polymeric material shall meet the intent of the requirement for the service temperature involved and, when not flat, comply with the mold stress relief requirements in the Standard for Polymeric Materials – Use in Electrical Equipment Evaluations, UL 746C.

52.3 Guards for torchiere style units

52.3.1 The following requirements apply to the guard over the lamp compartment of a torchiere style floor unit.

52.3.2 A guard shall be provided over the lamp compartment of a torchiere style floor unit.

52.3.3 A guard shall be constructed of:

- a) Plated or painted wire nominal 0.06 inch (1.5 mm) diameter wire;
- b) Metal, minimum 0.016 inch (0.41 mm) thick;
- c) Heat resistant glass such as tempered, annealed, or borosilicate glass:
 - 1) Minimum 1/8 inch (3.2 mm) (3.0 mm metric trade size) thick, when used with lamps rated 100 W or greater; or
 - 2) Minimum 3/32 inch (2.4 mm) thick, when used with lamps rated less than 100 W; or
- d) Porcelain or ceramic.

52.3.4 As depicted in Figure 52.2, the minimum guard-to-lamp containment barrier spacing shall be:

- a) 3 inches (76 mm) when measured from the center of the lamp containment barrier; and
- b) 2-3/8 inches (60 mm) when measured from the ends of the lamp containment barrier.

Figure 52.2
Guard for Torchiere style units

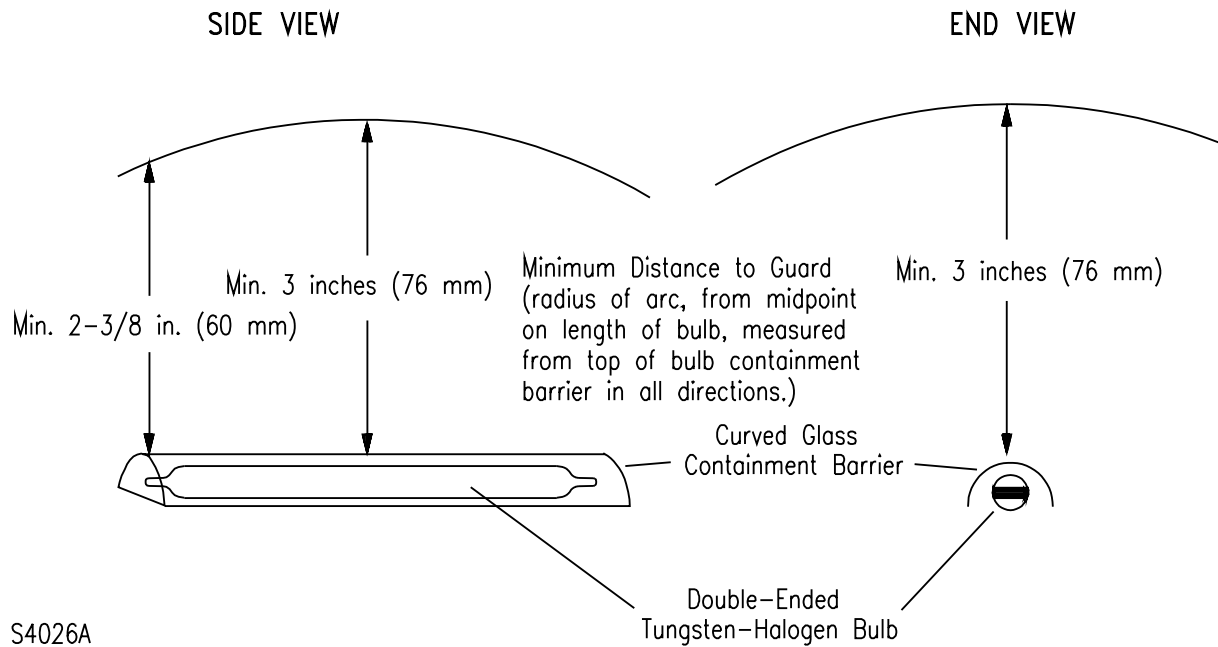

52.3.5 The minimum guard-to-lamp envelope spacing, when there is no independent lamp containment barrier, shall be:

- a) 3-1/2 inches (88.9 mm) measured at the center of the lamp containment barrier; and
- b) 2-7/8 inches (73 mm) measured at the ends of the lamp containment barrier.

52.3.6 The minimum guard-to-lamp containment barrier spacing of 52.3.4 or guard-to-lamp envelope spacing of 52.3.5 is not required to be met when the torchiere complies with the Heat Flux Density Measurement Test in Section 152.

52.3.7 The guard shall prevent the probes specified below from contacting the lamp containment barrier or the lamp envelope under the following conditions:

- a) A 1-1/2 inch (38.1 mm) diameter spherical probe inserted through the guard in any orientation; and
- b) A 0.4 inch (10 mm) thick, 1-3/8 inches (35 mm) wide and any convenient length flat plate probe, inserted vertically ± 45 degrees through the guard.

52.3.8 The guard shall be installed at the factory.

52.3.9 Any guard that is required to be moved to relamp shall be attached to the unit on one side by means of a hinge, tether, swivel, or similar device.

52.3.10 Any guard that does not require the use of tools to remove it shall have the guard removed during the abnormal operations tests of Sections 143 – 146.

52.3.11 A torchiere design that complies with the abnormal operations tests of Sections 143 – 146 with the guard removed shall be exempt from the requirement in 52.3.10.

52.3.12 A torchiere designed for a single-ended tungsten-halogen lamp shall be exempt from the guard requirements in 52.3.2 when:

- a) The lamp is provided with an integral outer envelope for which the lamp manufacturer does not require a lamp containment barrier;
- b) The unit complies with the Heat Flux Density Measurement Test in Section 152 and the abnormal operations test of Sections 143 – 146;
- c) The lamp is provided with the unit as specified in 52.1.6; and
- d) The unit is marked in accordance with 171.1.2 and provided with instructions in accordance with 185.2.

52.4 Lamp containment barrier

52.4.1 A tungsten-halogen type unit shall be provided with a lamp containment barrier (as defined in 2.21) that complies with the requirements in this Section.

Exception: A portable luminaire intended for use with a single-ended tungsten-halogen lamp with an integral outer envelope for which the lamp manufacturer does not require a guard or lamp containment barrier is not required to be provided with a lamp containment barrier when the unit is marked in accordance with 171.2.2 or 171.2.4.

52.4.2 A lamp containment barrier shall not have any holes greater than 1/8 inch (3.2 mm) diagonally or in diameter.

Exception: A lamp containment barrier is able to have open holes greater than 1/8 inch diagonally or in diameter when the openings are not line-of-sight between the lamp and any points outside of the portable luminaire.

52.4.3 A lamp containment barrier shall be constructed of:

- a) Metal, minimum 0.016 inch (0.41 mm) thick;
- b) Heat resistant glass such as tempered, annealed or borosilicate glass;
 - 1) Minimum 1/8 inch (3.2 mm) (3.0 mm metric trade size) thick when used with lamps rated 100 W or greater; or
 - 2) Minimum 3/32 inch (2.4 mm) thick when used with lamps rated less than 100 W;

- c) Porcelain or ceramic; or
- d) A polymeric material, minimum 3/32 inch (2.4 mm) thick.

52.4.4 A polymeric lamp containment barrier shall comply with the Polymeric Lamp Containment Barrier Test, Section 150, for the service temperature involved. When not flat, it shall comply with the mold stress relief requirements in the Standard for Polymeric Materials – Use in Electrical Equipment Evaluations, UL 746C.

52.5 Ultraviolet (UV) filter

52.5.1 A portable luminaire intended for use with only double envelope tungsten-halogen type lamps and that is marked in accordance with 171.2.2 or 171.2.4 is determined to comply with the UV filter requirements in this Section.

52.5.2 A portable luminaire that is able to be used with single envelope tungsten-halogen type lamps – lamps not provided with an integral outer glass envelope shall be provided with a UV filter.

Exception No. 1: A portable luminaire in which the light source is located 5 feet (1.5 m) or more above the floor, and the light source is directed only in the upward direction (i.e., torchiere style) is not required to be provided with a UV filter.

Exception No. 2: A surface mounted unit marked in accordance with 171.4 to indicate mounting a minimum of 5 feet above the floor and the light source is directed only in the upward direction is not required to be provided with a UV filter.

52.5.3 A downlight diffuser provided on a portable luminaire that is constructed as described in the Exceptions No. 1 and No. 2 to 52.5.2 shall comply with the UV filter requirements of this Section.

52.5.4 A UV filter shall be constructed of:

- a) Sodaslime glass, or glass with transmission characteristics in accordance with Table 52.1. Either type shall be minimum 1/8 inch (3.2 mm) (3.0 mm metric trade size) thick for over 100 W or 3/32 inch (2.4 mm) thick for 100 watts or less; or
- b) A polymeric material with transmission characteristics in accordance with Table 52.1 and minimum 3/32 inch (2.4 mm) thick.

Table 52.1
Ultraviolet transmission characteristics

Wavelength, nanometers	Maximum transmission, percent
350	85
320	40
300	8
290	0.5
less than 280	0.1

52.5.5 A polymeric UV filter shall be:

- a) Resistant to UV radiation in compliance with the requirements in the Standard for Polymeric Materials – Use In Electrical Equipment Evaluations, UL 746C;
- b) Meet the intent of the requirement for the service temperature;
- c) Rated HB minimum; and
- d) When not flat, comply with the mold stress relief requirements in UL 746C.

52.5.6 Any open holes in the UV filter shall be provided with a barrier complying with 52.5.4 or constructed of metal to prevent the emission of direct light from the lamp. All open holes shall be less than 1/8 inch (3.2 mm) diagonally or in diameter. The evaluation is done for each position that is attainable by an adjustment means.

52.5.7 The portable luminaire shall be marked in accordance with 171.3.2 when not provided with an interlock switch specified in Interlock Switch, 53.2 that de-energizes the lamp when the unit is opened for lamp replacement.

52.6 Flexible or articulated arms

52.6.1 A floor mounted tungsten-halogen torchiere style portable luminaire with a flexible or articulated arm that employs end-stops to limit arm adjustment shall comply with the following:

- a) The end-stops shall be factory installed;
- b) The end-stops shall not be easily defeatable nor removable without the use of tools; and
- c) The unit shall be subjected to the Tungsten-Halogen Torchiere Flexible or Articulated Arm Stop Test described in Section 148.

53 Construction – Electrical

53.1 Switches

53.1.1 A switch in a tungsten-halogen type unit provided with double ended lamps shall be a double pole switch that simultaneously opens both conductors. The switch shall be clearly marked with an indication of the off position either adjacent to the switch or on the switch. The switch or dimmer is able to be the electronic (no air gap contacts) or mechanical type that complies with the Standard for Solid State Controls, for Appliances, UL 244A, or the Standard for Special-Use Switches, UL 1054.

Exception No. 1: No switch or a single pole switch is permitted for a portable luminaire where the lamp is connected to the secondary of an isolating transformer having a secondary rating of 30 volts or less.

Exception No. 2: No switch or a single pole switch is permitted for a lamp that:

- a) Requires a tool to gain access to replace the lamp; and*
- b) Is marked in accordance with 171.3.1 to indicate that the lamp is to be unplugged before replacing the lamp.*

53.2 Interlock switch

53.2.1 An interlock switch that de-energizes the lamp when a portable luminaire is opened for lamp replacement shall be either:

- a) Rated for the load it controls and comply with the Standard for the Special-Use Switches, UL 1054, or
- b) Comply with the requirements in 53.2.2 and 53.2.3 and the tests in 54.5.

53.2.2 Current-carrying parts shall be copper or copper alloy.

Exception: Stainless steel that is resistant to corrosion is able to be used for other than quick-connect terminals, push-in terminals, solder terminals, and arcing parts of a switch.

53.2.3 Electrical spacings shall comply with Electrical Spacings, Section 24.

53.2.4 A portable luminaire provided with an interlock that de-energizes the lamp when the unit is opened for lamp replacement is not required to be marked as specified in 171.3.2.

53.3 Automatic temperature-regulating or limiting control

53.3.1 An automatic temperature-regulating or limiting control or similar device shall be used only as supplementary protection and, when employed, shall be used in combination with a guard that complies with 52.3.

53.4 Tipover switch

53.4.1 A tungsten-halogen torchiere style floor unit that has a flexible or articulated arm shall be provided with a tipover switch in accordance with 53.4.

53.4.2 When a tipover switch is provided, the Severe Condition Test, 143.3, and the Tungsten-Halogen Torchire Vertical Wall Test, Section 146, are not required.

Exception: A tungsten-halogen torchiere style unit with a flexible or articulated arm is not exempt from the Tungsten-Halogen Torchire Vertical Wall Test.

53.4.3 A tipover switch shall de-energize the unit when tipped over in any direction.

53.4.4 A tipover switch used with a tungsten-halogen torchiere shall de-energize the unit when tipped beyond the angle that the unit would right itself.

54 Tests

54.1 Normal temperature test

54.1.1 A tungsten-halogen type unit is to be subjected to the Normal Temperature Test in Section 124, General, and Section 125, Test Method – General, except as provided for in 54.1.2.

54.1.2 A tungsten-halogen type unit that:

- a) Uses an Edison base, double envelope tungsten-halogen lamp similar in shape to a Type A incandescent lamp;
- b) Is rated 100 watts or less;
- c) Complies with the shade dimension requirements of Section 47 for Temperature Test Exempt Units employing a 100 watt lamp and a medium base; and
- d) Is marked in accordance with 171.3.1;

is not required to be subjected to the Temperature Test.

54.2 Tungsten-halogen lamp adjacent surfaces and overlamping abnormal operation tests

54.2.1 A tungsten-halogen type unit is to be subjected to the Tungsten-Halogen Lamp Adjacent Surfaces and Overlamping Abnormal Operation Tests in Section 143.

Exception: These requirements do not apply to portable luminaires intended for use with medium-base type A style double envelope tungsten-halogen lamps.

54.3 Tungsten-halogen torchiere abnormal operation tests

54.3.1 A tungsten-halogen portable floor unit having an open top design with the lamp facing upward, such as a torchiere style, shall not be rated in excess of 300 watts and shall comply with the Tungsten-Halogen Torchiere Abnormal Operation Test, Section 145, the Tungsten-Halogen Torchiere Vertical Wall Test, Section 146, and shall be marked in accordance with 171.3.6.

Exception: A unit other than a style having a flexible or articulated arm and provided with a tipover switch in accordance with 53.4 is not required to be subjected to the Tungsten-Halogen Torchiere Vertical Wall Test, Section 146.

54.4 Guard, lamp containment barrier & UV filter security tests

54.4.1 A tungsten-halogen type unit provided with a guard, lamp containment barrier and UV filter is to be subjected to the Tungsten-Halogen Lamp Guard, Lamp Containment Barrier and UV Filter Security Test in Section 144.

54.5 Polymeric lamp containment test

54.5.1 A tungsten-halogen type unit provided with a polymeric lamp containment barrier as described in 52.4.4 is to be subjected to the Polymeric Lamp Containment Barrier Test in Section 150.

54.6 Interlock switch tests

54.6.1 An interlock switch shall comply with the Normal Temperature Test, Section 124, General, and Section 125, Test Method – General, Dielectric Voltage-Withstand Test, Section 137, and the Interlock Switch Endurance Test, Section 151.

55 Marking

55.1 A tungsten-halogen type unit shall comply with the markings specified in Section 171, Tungsten Halogen Units.

56 Instructions

56.1 A tungsten-halogen type unit shall comply with the instructions specified in Section 185, Tungsten-Halogen Units.

FLUORESCENT UNITS – SUPPLEMENTARY

57 General

57.1 The requirements specified in Section 57 – 61 apply to portable luminaires using fluorescent lamps.

57.2 These requirements are supplementary to other applicable requirements in this Standard.

58 Construction – Electrical

58.1 Ballasts

58.1.1 A ballast having an open circuit voltage greater than 1000 volts shall not be used.

58.2 Lampholder

58.2.1 A lampholder shall have a minimum voltage rating equal to or greater than the ballast marked output voltage rating and/or marked open circuit voltage.

58.2.2 Simple reactance ballasts and Class P ballasts not marked with an output voltage rating and/or open circuit voltage rating shall be used with lampholders rated at least 250 V.

58.2.3 Circuit interrupting lampholders shall be used at each end of each lamp with any ballast that is marked for use with circuit interrupting lampholders for that particular lamp.

Exception: Other configurations shown on the ballast marking or wiring diagram are able to be used.

58.2.4 A portable luminaire shall not use lampholders designed for ferrule-type lamps.

58.3 Wire temperature ratings

58.3.1 The internal wiring of a fluorescent type unit shall meet the requirement for temperatures specified in Table 58.1.

Table 58.1
Wire temperature rating of a portable luminaire employing fluorescent lamps

Position of wiring	Minimum temperature rating of wiring ^a	
	°C	°F
Permanently spaced at least 3 inches (76 mm) from any ballast	60	140
Less than 3 inches from, and not in contact with, any ballast except at the point of entry to the ballast	80 ^b	176
In contact with any ballast	90 ^b	194
^a Leads permanently attached to a ballast or an electric-discharge-lamp lampholder are rated for a temperature of at least 75°C (167°F).		
^b Wiring provided with an outer braid is usable for 75°C (167°F) minimum.		

58.4 Power-supply cord

58.4.1 When an external ballast is connected in the power-supply cord, the overall length of the cord, including the ballast, shall not be less than 5 feet (1.5 m), and the ballast shall be at least 2 feet (0.61 m) from the attachment plug.

Exception: When a direct plug-in ballast is used, the overall length of the cord shall not be less than 5 feet (1.5 m) to the ballast from the point where the cord emerges from the body of the lamp.

58.5 Grounding

58.5.1 A portable luminaire having a ballast with an open circuit voltage in excess of 150 volts shall have a grounding type attachment plug.

59 Tests

59.1 Normal temperature test

59.1.1 A fluorescent type unit shall be temperature tested in accordance with the Normal Temperature Test, Section 124, General, and Section 125, Test Method – General, except as provided by Section 60, Temperature Test-Exempt Units.

59.1.2 A portable luminaire that incorporates features requiring additional evaluation, such as a power factor correction capacitor in series with a simple reactance ballast, a compact fluorescent lamp, a motor, or a polymeric enclosure material, is required to be subjected to a temperature test.

59.2 Abnormal operation shorted starter test

59.2.1 A fluorescent type unit that is provided with other than a manual starter shall be subjected to the Abnormal Operation – Shorted Starter Test as described in Section 153.

Exception: When the ballast is a Class P ballast, the test is not required to be conducted.

60 Temperature Test-Exempt Units

60.1 A fluorescent portable luminaire is not required to be subjected to the Normal Temperature Test in Section 124, General, and Section 125, Test Method – General, when provided with:

- a) A single Class P ballast;
- b) Straight tubular lamps and a single simple reactance type ballast without a power-factor correction capacitor in series; or
- c) More than one ballast per (a) or (b) above with the spacing between any two ballasts not less than 1 inch (25 mm) when arranged end-to-end and not less than 4 inches (100 mm) when arranged otherwise. See Figure 60.1.

Figure 60.1
Typical ballast configuration

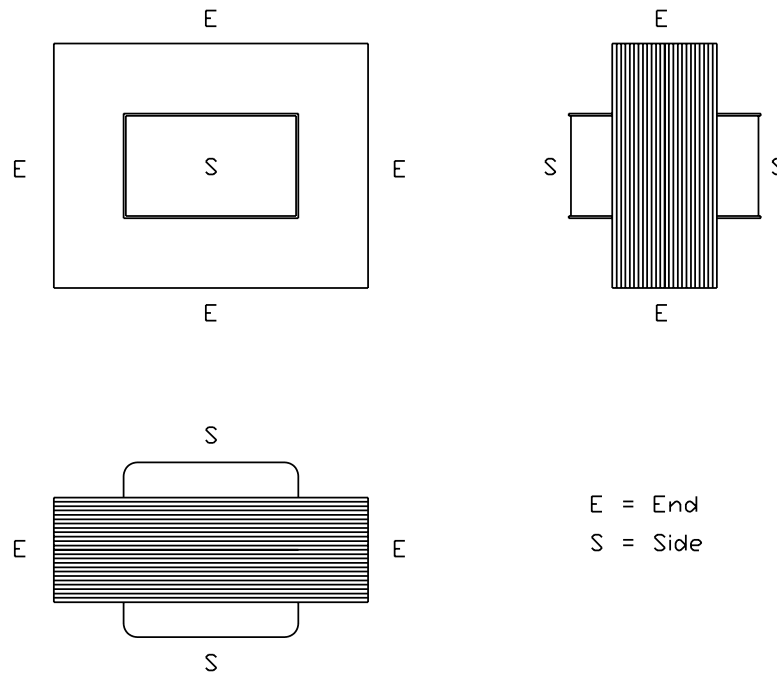

SM1076

60.2 Internal wiring for a fluorescent portable luminaire not subjected to a temperature test in accordance with 60.1 shall be:

- a) Rated minimum 60°C when permanently spaced at least 3 inches (76 mm) from any ballast;
- b) Rated minimum 80°C when within 3 inches (76 mm), and not in contact with any ballast; or
- c) Rated minimum 90°C when in contact with any ballast.

60.3 Integral leads of a ballast or lampholder are determined as usable for 75°C or higher, when so marked.

60.4 Wiring provided with an outer braid is determined usable for 90°C.

61 Marking

61.1 A fluorescent type unit shall comply with the markings specified in Section 172, Fluorescent Units.

HIGH INTENSITY DISCHARGE UNITS – SUPPLEMENTARY

62 General

62.1 The requirements specified in Sections 62 – 66 apply to portable luminaires using high intensity discharge lamps.

62.2 These requirements are supplementary to other applicable requirements in this Standard.

63 Construction – Mechanical

63.1 Metal halide lamp containment and UV filter

63.1.1 A portable luminaire for use with a metal halide lamp shall be provided with lamp containment barrier in accordance with the requirement for Lamp Containment Barrier, 52.4.

63.1.2 A portable luminaire for use with a metal halide lamp that is not provided with an integral outer glass envelope shall additionally be provided with a UV filter in accordance with the requirements for Ultraviolet (UV) Filter, 52.5.

64 Construction – Electrical

64.1 Lampholders

64.1.1 A lampholder for a high pressure sodium lamp shall have a minimum pulse voltage rating of 4 kV or at least the pulse voltage output of the lamp igniter, whichever is greater.

64.2 Ballasts

64.2.1 A portable luminaire shall be provided with a ballast rated for the intended lamp and shall be electrically connected in accordance with the diagram or instructions on or with the ballast.

64.3 Capacitors

64.3.1 A portable luminaire having a capacitor as a component separate from the ballast shall incorporate means, such as a bleeder resistor, for the automatic discharge of the capacitor within 1 minute after removal of the lamp from the circuit or after opening of the primary circuit, or both. The voltage (V) at the end of 1 minute across the terminals shall be reduced to a value of 50 volts or less, and the energy stored (J) shall be less than 20 joules as determined by the equation:

$$J = 5 \times 10^{-7} CV^2$$

where:

C is the capacitor rating in microfarads.

64.3.2 To comply with 64.3.1, the maximum resistance value of a bleeder resistor shall be determined by the equation:

$$R = \frac{K}{C}$$

where:

R is the resistance value in megohms;

K is the resistor factor determined from Table 64.1; and

C is the capacitor rating in microfarads.

Table 64.1
Bleeder resistor factor (K)

Voltage		Factor (K)
Peak	rms ^a	
0 – 100	0 – 70	85
101 – 110	71 – 78	76
111 – 120	79 – 85	70
121 – 130	86 – 92	63
131 – 140	93 – 99	55
141 – 150	100 – 106	54
151 – 170	107 – 120	50
171 – 200	121 – 141	44
201 – 240	142 – 169	39
241 – 280	170 – 197	35
281 – 325	198 – 230	32
326 – 375	231 – 265	30
376 – 450	266 – 318	27
451 – 500	319 – 353	26
501 – 700	354 – 495	23
701 – 1000	496 – 707	19

^a For a transformer type ballast, the voltage value to be applied from this table is the rms voltage rating of the capacitor as specified by the ballast.

64.3.3 The requirement in 64.3.2 is to be met without the use of a bleeder resistor when the capacitor is located in a closed loop of the circuit and when the loop is not opened by removal of the lamp or by the opening of a switch, fuse, or similar device.

64.4 Nonintegral oil-filled capacitors

64.4.1 When an oil-filled capacitor is not integral with the ballast, its characteristics and installation shall comply with the requirements of this Section.

64.4.2 A capacitor shall comply with the requirements for capacitors in, UL 810, the Standard for Capacitors, and shall be rated for the voltage to which it is to be connected. Such capacitors relieve an internal fault condition by movement of the terminal end of the capacitor enclosure to break the circuit internally. Movement is initiated by internal pressure during a fault condition, causing expansion of the capacitor body.

64.4.3 A capacitor shall be rated not less than the maximum fault current to which it is subjected, as follows:

- a) A value of 5,000 amperes when connected across the ballast primary; that is, when the capacitor is in parallel with the ballast input circuit;
- b) A value of 200 amperes when connected in series with a ballast coil; or
- c) The maximum current available to the capacitor under capacitor short-circuit condition, as determined by an investigation.

64.4.4 The placement and mounting of a capacitor in a portable luminaire shall be such that a free air space is provided in front of the capacitor end-terminals to enable the capacitor to expand, without obstruction, under a fault condition. This expansion clearance space shall be such that the front enclosure and terminals of the capacitor, with associated wire connectors and supply leads attached, to travel 1/2 inch (12.7 mm) in a direction perpendicular to the mounting surface of the terminals.

Exception: The expansion clearance space is to be less than 1/2 inch (12.7 mm) when an investigation determines that the space required for a particular capacitor is provided.

64.4.5 In addition to the expansion clearance space specified in 64.4.4, an electrical air spacing between any exposed live part of the capacitor, such as exposed terminals and wire connectors, and any uninsulated live part of opposite polarity or uninsulated, grounded dead metal parts shall (after expansion) be:

- a) At least 1/16 inch (1.6 mm) when the voltage involved does not exceed 300 volts; or
- b) At least 1/8 inch (3.2 mm), when the voltage involved exceeds 300 volts.

65 Tests

65.1 Normal temperature test

65.1.1 A high intensity discharge type unit shall be subjected to the Normal Temperature Test in Section 124, General, and Section 125, Test Methods – General.

65.1.2 The test of one ballast to represent others meets the intent of the requirement with the following exceptions:

- a) A metal halide or mercury vapor type is unable to represent a high pressure sodium (HPS) type.
- b) A HPS type is unable to represent a metal halide or mercury vapor type.
- c) A lower wattage type is unable to represent a higher wattage type.
- d) A ballast with one class insulation system is unable to represent a ballast with a different class insulation system.
- e) For a ballast of other than the enclosed and potted type with a Class 105 insulation system, a ballast with a bench-test temperature is unable to represent a ballast with a higher bench-test temperature.
- f) An unprotected ballast is unable to represent a protected ballast when the protector:
 - 1) Is buried within the ballast and has a temperature rating of less than the rating of the ballast insulation system; or
 - 2) Is located directly on the ballast core or under the wrap of an open coil and has a temperature rating of less than 90°C (194°F) for a Class 105 system, 110°C (230°F) for a Class 130 system, or 150°C (302°F) for a Class 180 system.

65.2 Glass impact test

65.2.1 A unit intended for use with a metal halide lamp without an integral outer envelope and provided with a glass lamp containment barrier is to be subjected to the Glass Impact Test, Section 154.

65.3 Glass thermal shock/containment test

65.3.1 A unit intended for use with a metal halide lamp and provided with a glass lamp containment barrier of other than tempered or borasilicate glass is to be subjected to the Glass Thermal Shock/Containment Test, Section 155.

66 Markings

66.1 A high intensity discharge type unit shall comply with the markings specified in Section 173, High-Intensity-Discharge Units.

SURFACE MOUNTED UNITS FOR WALL, UNDER-CABINET OR APPLIANCE MOUNTING – SUPPLEMENTARY

67 General

67.1 These requirements specified in Sections 67 – 70 apply to surface mounted products with the following mounting means:

- a) Wall Mounted Units – as specified in Section 68;
- b) Under-Shelf Units – as specified in Section 69; and
- c) Appliance Mounted Units – as specified in Section 70.

67.2 These requirements are supplementary to other applicable requirements in this Standard.

67.3 These requirements do not apply to the following products and mounting means:

- a) Free standing units;
- b) Cord and chain suspended units– as specified in Sections 71 – 76;
- c) Clamp-on mounted units – as specified in Sections 77 – 80;
- d) Portable cabinet lights covered in Sections 81 – 86; and
- e) Track-style type units covered in Sections 101 – 106.

68 Wall Mounted Units

68.1 General

68.1.1 These requirements apply to portable luminaires intended to be mounted to a wall, or to a similar structural surface.

68.2 Construction – mechanical

68.2.1 A wall mounted unit shall comply with the conditions specified in Table 68.1 to determine the mounting means requirements.

Table 68.1
Mounting requirements

Maximum weight		Conditions
Pounds	(kg)	
2-1/4	(1.0)	(A or B) and (C or D)
4-1/4	(1.9)	[(A or B) and D] or E
Greater than 4-1/4	(1.9)	F

^a A wall unit shall not project more than 7-1/2 inches (190 mm) from a flat vertical wall on which the unit is mounted in the intended manner. The projection is to be measured to the farthest point on the lampholder with an adjustable unit adjusted to the position that gives the maximum projection from the wall.

^b The center of gravity of a wall unit shall not be more than 3 inches (76.2 mm) from the vertical wall on which the unit is hung in the intended manner, the center of gravity being determined with any adjustment that gives a maximum projection from the wall.

^c A unit is provided with either a ring-hanger, keyhole slot(s), or notch(es).

^d A unit is provided with mounting hardware consisting of at least two No. 6 Type A sheet metal screws of a length that the screws, when installed in the mounting holes, penetrate the mounting surface by not less than 3/4 inch (19 mm).

^e A unit is provided with mounting hardware consisting of at least two No. 10 – 24 machine screws with mating hollow-wall anchors, or wing or expansion bolts. The screws shall be of a length that the anchors, or wing or expansion bolts are able to be installed through the mounting holes and a 3/4 inch (19 mm) thick wall.

^f A unit is to be provided with mounting hardware that complies with the Mounting Means Test – Surface Mounted Unit, Section 156.

68.2.2 In determining compliance with 68.2.1, the weight of the portable luminaire shall be determined by weighing the complete unit with the exception of the mounting hardware. When the lamp shade is not provided, 1/4 pound (113 g) shall be added for each lampholder to reflect the weight of the shade. When a shelf, bowl, hook or any means of support of any object, other than a shade, is provided, the weight of the intended object shall be included.

68.2.3 A wall mounted unit is able to be provided with a separable bracket used to secure the product to a vertical mounting surface in accordance with 68.2.1.

68.3 Construction – electrical

68.3.1 The wall mounted unit shall comply with the requirements for Enclosure, Section 9, and the requirements for Accessibility of Live Parts, Section 23, without dependence on the intended mounting surface or any separable bracket.

68.3.2 The power supply cord shall exit the portable luminaire from a surface other than the one abutting the vertical wall.

68.4 Tests

68.4.1 Mounting means

68.4.1.1 A surface mounted unit required to be tested as specified in Table 68.1, Condition F shall be subjected to the Mounting Means Test – Surface Mounted Unit, Section 156.

68.5 Instructions

68.5.1 A surface mounted unit shall be provided with installation instructions as specified in Section 186, Surface Mounted Units.

69 Under-Shelf Mounted Units

69.1 General

69.1.1 These requirements apply to portable luminaires intended to be mounted under a shelf, cabinet, or similar structural surface.

69.2 Mounting means

69.2.1 An under-shelf mounted unit shall be provided with a means for mounting in accordance with Section 68, Wall Mounted Units, except as follows:

- a) Only Conditions C and F from Table 68.1 are applicable. The keyhole slots in Condition C are able to be open to facilitate mounting in place and tightening of mounting screws;
- b) Each term "wall mounted" shall be replaced with "under-shelf mounted" and each term "vertical" that references the mounting surface shall be replaced with "horizontal"; and
- c) The Exception to 156.2.1 does not apply and the surface mounted instructions in Section 186, Surface Mounted Units, shall specify the intended mounting surface.

69.3 Construction – electrical

69.3.1 Attachment plugs and receptacles

69.3.1.1 A plug or a receptacle shall be rated not less than 15 A, for under-shelf mounted units that are not provided with overcurrent protection.

69.3.2 Wiring

69.3.2.1 An interconnecting cord for under-shelf mounted units shall be in accordance with Table 27.1 and rated 105°C minimum.

Exception: For a Class 2 circuit, wire or cord other than specified in Table 27.1 or of a lower temperature rating is able to be used, including appliance wiring material, when the insulation is rated for the maximum temperature and voltage involved.

69.3.2.2 Low voltage wiring shall have an ampacity rating in accordance with Table 26.1. Overcurrent protection for low voltage wiring is not required.

69.3.3 Insulating barriers for fluorescent lamp components

69.3.3.1 A fluorescent under-shelf unit shall be provided with insulating material not less than 1/32 inch (0.8 mm) thick between a metal enclosure and:

- a) The enclosure of a ballast;
- b) A splice or fixture-type wire connector; and
- c) A dead metal part – including a mounting screw, rivet, yoke, clamp, and similar parts – of an electrical component, such as a lamp holder, switch, or receptacle.

Exception No. 1: Insulating material is not required to be provided when the construction of the component results in a separation of not less than 1/2 inch (12.7 mm) between dead metal parts and live parts of the component.

Exception No. 2: Insulating material is not required to be provided in a unit that is provided with a grounding attachment plug and constructed in accordance with Grounding and Bonding, Section 36.

69.4 Tests

69.4.1 Mounting means test

69.4.1.1 An under-shelf mounted unit required to be tested as specified in Table 68.1, Condition F shall be subjected to the Mounting Means Test – Surface Mounted Unit, Section 156, and as modified in 69.2.

69.5 Markings

69.5.1 An under-shelf mounted unit shall comply with the installation instructions specified in 186.1 and as modified in 69.2.

70 Appliance Mounted Units

70.1 General

70.1.1 A portable luminaire that is intended to be mounted on a cord-connected appliance, such as a sewing machine, or on a portable nonelectrical product, such as a picture, music stand, or portable furnishing, is able to have provision for permanent or semipermanent mounting.

70.2 Instructions

70.2.1 An appliance mounted unit shall comply with the installation instructions specified in 186.2.

CORD AND CHAIN SUSPENDED UNITS – SUPPLEMENTARY

71 General

71.1 The requirements specified in Sections 71 – 76 apply to a portable luminaire that is intended for suspension from the ceiling. Such a lamp is able to be provided with a chain.

71.2 These requirements are supplementary to other applicable requirements in this Standard.

71.3 For the purposes of this Section, the following definitions apply:

- a) "Swag" type unit – A chain-suspended portable luminaire.
- b) "Hanging" type unit – A power-supply cord-suspended portable luminaire not provided with a chain.
- c) "Portable luminaire" or "unit" – Either a swag or a hanging type portable luminaire.

71.4 A portable luminaire suspended from a wire, cable, or equivalent means shall comply with the chain-suspended requirements except as noted in 72.1.1.

72 Construction – Mechanical

72.1 Chains

72.1.1 A swag type unit shall be provided with not more than 15 feet (4.6 m) of metal chain, and not less than 9 feet (2.7 m) of metal chain.

Exception No. 1: Less chain is able to be provided when the unit is marked in accordance with Section 174, Cord and Chain Suspended Units.

Exception No. 2: A specific length of chain is not required when the power-supply cord is not routed through it.

72.1.2 When there are supplementary chain segments attached to an extended arm, a splice compartment, and similar components, the length of the chain is determined to be the length of the principal segment plus the length of the longest supplementary segment, plus the length of any other segment over 12 inches (305 mm) long. When all supplementary segments are the same length and not more than 12 inches (305 mm) long, the length of the chain is determined to be the length of the principal segment plus the length of only one supplementary segment.

72.2 Support hardware

72.2.1 The support hardware for a portable luminaire shall consist of:

- a) At least two metal hooks, each with a No. 10-24 threaded hole that engages the bolt threads;
- b) Two wing bolts, each consisting of a No. 10-24 bolt, 2-7/8 inches (73 mm) long with two tapered wings 1 by 5/16 inch (25.4 by 7.9 mm); and
- c) Two studs – combination wood screw-machine screw – measuring 1-3/4 inches (44.4 mm) overall and having 1-1/4 inches (31.8 mm) of wood screw threads on one end and at least six No. 10-24 machine screw threads on the other end.

Exception No. 1: A form of support hardware, other than that specified, is able to be supplied when it is investigated in accordance with the Mounting Means Test – Chain and Suspended Units, Section 157, and determined to meet the intent of the requirement for the support of the unit.

Exception No. 2: A hanging type unit is capable of being provided with plastic hooks instead of metal hooks.

72.2.2 In addition to the hardware specified in 72.2.1, a hanging type unit provided with metal hooks shall also be provided with insulators to protect the cord.

72.3 Maximum weight

72.3.1 The weight of a swag type unit, including the shade, glassware, 4 feet (1.2 m) of chain, and any anticipated additional loading shall not exceed 30 pounds (13.6 kg).

Exception: The total weight is able to be more than 30 pounds (13.6 kg) when the unit is tested in accordance with the Mounting Means Test – Chain and Suspended Units, Section 157.

72.3.2 A swag type unit that is provided with a bowl, a shelf, or a hook intended for the support of any object that is not part of the portable luminaire itself, other than the shade, shall be investigated to determine that provision for the support of the additional weight does not result in the total weight exceeding the 30 pounds (13.6 k) specified in 72.3.1. It is not possible to specify the conditions of mechanical loading for all forms of constructions; however, the most severe conditions of anticipated use and abuse shall be evaluated – for example, a bowl is to be filled to capacity with dry sand and additionally filled with water.

Exception: The total weight is able to be more than 30 pounds (13.6 kg) when the unit is tested in accordance with the Mounting Means Test – Chain and Suspended Units, Section 157.

72.3.3 The weight of a hanging type unit (cord suspended), including the shade, glassware, and any anticipated additional loading shall not exceed the cord specifications in Table 72.1.

Table 72.1
Cord loading

Cord type	Maximum total weight of cord load	
	Pounds	(kg)
SP-2, SPE-2, SPT-2, SV, SVE, SVEO, SVO, SVOO, SVT, SVTO, SVTOO	2-1/2	(1.1)
SJ, SJE, SJO, SJEO, SJOO, SJT, SJTO, SJTOO, S, SE, SOO, SO, SEO, ST, STOO, STO	10	(4.5)

72.3.4 A hanging type unit (cord suspended) shall not be provided with a bowl, shelf, or hook intended to support any object that is not part of the hanging lamp.

72.3.5 A hanging unit having play value in accordance with Section 18, Portable Luminaires Having Play Value, shall be tested in accordance with the Tests for Suspended Toys, Section 158.

73 Construction – Electrical

73.1 Internal wiring protection

73.1.1 Wiring and splices within a metal enclosure shall be provided with supplementary insulation having a minimum temperature rating of 105°C (220°F), or the wiring and splices shall be kept from contacting the metal of an enclosure.

73.1.2 With reference to the requirement in 73.1.1, the supplementary insulation is to consist of not less than 0.01 inch (0.3 mm) thick:

- a) Woven glass tape; or
- b) Snug-fitting woven glass sleeving or insulating tape or tubing.

73.1.3 Flexible cord that has had the outer jacket removed is regarded as internal wiring and shall comply with the requirements in 73.1.1.

73.1.4 Flexible cord that has been split is regarded as internal wiring and shall comply with the requirements in 73.1.1.

73.2 Power-supply cord

73.2.1 The power supply cord for a swag type unit shall:

- a) Be at least 15 feet (4.6 m) long from the point where the cord emerges from the body of the lamp to the face of the attachment plug or connector, and extend not less than 1 foot (0.3 m) nor more than 6 feet (1.8 m) beyond the end of the chain; and
- b) Have insulation rated for 105°C (221°F).

Exception: The cord is able to be less than 15 feet long when the unit is marked in accordance with 174.1.

73.2.2 The flexible cord for a hanging type unit shall:

- a) Be at least 15 feet (4.6 m) long from the point where the cord emerges from the body of the unit to the face of the attachment plug or connector;
- b) Have insulation rated for 105°C (221°F); and
- c) Be of a type specified in Table 72.1.

73.3 Lampholders and switches

73.3.1 Dead metal parts of a lampholder or a switch (such as a mounting bracket, nipple, or pull chain) shall be:

- a) Inaccessible in accordance with Accessibility of Live Parts, Section 23; and
- b) Enclosed in metal, glass, marble, porcelain, or phenolic, or spaced at least 3/64 inch (1.2 mm) from accessible dead metal of the lamp.

Exception No. 1: A dead metal part of a component is not required to be insulated or spaced away from the accessible dead metal of the lamp when all of the following conditions are met:

- a) The conductors are permanently assembled to the component by the manufacturer of the component in such a manner that replacement of the conductors connected to the component requires disassembly of the component by removal of a rivet, drive screw, drive pin, or the equivalent.*
- b) A barrier or liner of insulating material, minimum 1/32 inch (0.8 mm) thick, such as electrical grade fiber, is interposed between all live parts and dead metal parts. When the barrier or liner is not integral with the body of the component, it is to be reliably secured in position.*

Exception No. 2: When the dead metal of the portable luminaire is grounded in accordance with Grounding and Bonding, Section 36, dead metal parts of the component shall also be grounded.

Exception No. 3: Dead metal of a through-cord switch is not required to be inaccessible.

Exception No. 4: Such parts are not required to be inaccessible to contact during relamping.

73.3.2 A lampholder shall have a body and base (or cap) of insulating material. Metal shell lampholders and/or lampholders with exposed terminals shall not be used.

73.3.3 When the insulating body of an incandescent lampholder is provided with an integral metal nipple or tube, the inner end of the nipple or tube shall not extend inward beyond the inner surface of the lampholder body.

73.3.4 A through-cord switch shall be located at least 1-1/2 inches (38 mm) from accessible dead metal of the portable luminaire.

74 Tests

74.1 Mounting means test

74.1.1 A cord and chain suspended unit required to be tested as specified in the Exception 1 to 72.2.1 shall be subjected to the Mounting Means Test – Chain and Suspended Units, Section 157.

74.2 Tests for suspended toys

74.2.1 A cord and chain suspended unit having play value in accordance with Portable Luminaires Having Play Value, Section 18, shall be subjected to the Tests for Suspended Toys, Section 158.

75 Markings

75.1 A cord and chain suspended unit shall be provided with markings as specified in Section 174, Cord and Chain Suspended Units.

76 Instructions

76.1 A cord and chain suspended unit shall be provided with instructions as specified in Section 187, Cord and Chain Suspended Units.

CLAMP-ON MOUNTED UNITS – SUPPLEMENTARY

77 General

77.1 These requirements specified in Sections 77 – 80 apply to portable luminaires that are provided with clamps as the mounting means.

77.2 These requirements are supplementary to other applicable requirements in this Standard.

78 Construction – Mechanical

78.1 Clamp

78.1.1 A clamp relying on a spring-actuated clip for securement shall hold the portable luminaire to surfaces from 1/16 inch (1.6 mm) thick to 1-1/2 inches (38 mm) thick.

78.1.2 A clamp shall not require the use of tools to adjust the clamp.

Exception: A clamp intended for a specific application (such as mounting to office furnishings) is not required to comply with this requirement.

78.1.3 A thumb screw knob provided to tighten a clamp shall be at least 7/8 inch (22.2 mm) in diameter.

78.1.4 When a spring-actuated clamp employs a friction-type material secured by an adhesive, the adhesive bond shall comply with the requirements in UL 746C, the Standard for Polymeric Materials – Use in Electrical Equipment Evaluations.

Exception No. 1: Molded-in, ultrasonic, or solvent bonded friction materials do not require additional evaluation of the bond.

Exception No. 2: Evaluation of the adhesive bond is not required when the Mounting Means Test – Clamp-On Unit, Section 159, is conducted without the friction material in place.

79 Construction – Electrical

79.1 Power-supply cords

79.1.1 The power supply cord for a clamp-on unit shall be rated 105°C (221°F) and secured directly to the lampholder.

79.2 Lampholders and switches

79.2.1 Dead metal parts of a lampholder or a switch (such as a mounting bracket, nipple, or pull chain) shall be:

- a) Inaccessible in accordance with Accessibility of Live Parts, Section 23; and
- b) Enclosed in metal, glass, marble, porcelain, or phenolic, or spaced at least 3/64 inch (1.2 mm) from accessible dead metal of the portable luminaire.

Exception No. 1: A dead metal part of a component is not required to be insulated or spaced away from the accessible dead metal of the unit when all of the following conditions are met:

- a) The conductors are permanently assembled to the component by the manufacturer of the component in such a manner that replacement of the conductors connected to the component requires disassembly of the component by removal of a rivet, drive screw, drive pin, or the equivalent.*
- b) A barrier or liner of insulating material, minimum 1/32 inch (0.8 mm) thick, such as electrical grade fiber, is interposed between all live parts and dead metal parts. When the barrier or liner is not integral with the body of the component, it is to be reliably secured in position.*

Exception No. 2: When the dead metal of the unit is grounded, the dead metal parts of the component shall also be grounded.

Exception No. 3: Dead metal of the through-cord switch is able to be accessible.

Exception No. 4: Such parts are not required to be inaccessible to contact during relamping.

79.2.2 A lampholder shall have a body and base (or cap) of insulating material. Metal shell lampholders and/or lampholders with exposed terminals shall not be used.

79.2.3 When the insulating body of an incandescent lampholder is provided with an integral metal nipple or tube, the inner end of the nipple or tube shall not extend inward beyond the inner surface of the lampholder body.

79.2.4 A through-cord switch shall be located at least 1-1/2 inches (38 mm) from accessible dead metal of the portable luminaire.

80 Tests

80.1 Mounting means test

80.1.1 A clamp relying on a spring-actuated clip for securement shall comply with the Mounting Means Test – Clamp-On Unit, Section 159.

PORTABLE CABINET LIGHTS – SUPPLEMENTARY

81 General

81.1 The requirements specified in Sections 81 – 86 apply to portable luminaires intended for final installation into a cabinet (Open or Enclosed) such as a china hutch, bookcase, bar, console, bed headboard or similar items.

81.2 A surface mounted portable cabinet light is also suitable for installation under a shelf or kitchen cabinet when the line voltage power supply cord is not concealed.

81.3 A recessed mounted portable cabinet light connected to a Class 2 power supply is suitable for installation in a kitchen cabinet or other built-in furnishing, when the power supply and the line voltage power supply cord is not concealed.

81.4 These requirements are supplementary to other applicable requirements in this Standard.

82 Construction – Mechanical

82.1 Mounting flange

82.1.1 A pot style portable cabinet light shall have the mounting flange secured by means other than friction alone such as clamping with mechanical stop to limit adjustment, twist and lock, mechanical fasteners, or multiple spring clips that hook over the mounting surface. A strain relief bushing, bent tabs, or raised dimples in combination with a clamp meets the intent of the requirement.

83 Construction – Electrical

83.1 Power-supply cords

83.1.1 The power supply cord shall be at least 10 feet (3.05 m) in length.

Exception: A shortened cord is able to be used in accordance with the requirements of 83.1.4.

83.1.2 The 10 feet of cord required by 83.1.1 is to be measured from the plug to the entrance into the first portable luminaire or accessory (switch, dimmer, or similar equipment).

83.1.3 Means shall be provided to support the cord to reduce risk of contact with the portable cabinet light at a location other than the cord exit.

83.1.4 A portable cabinet light provided with a shortened cord in accordance with 34.3 shall be marked in accordance with 175.3 and be provided with:

- a) An attachment plug as specified in Attachment Plugs, Section 32; or
- b) A non-NEMA standard plug.

83.2 Interconnecting cord

83.2.1 A length of Type SPT-2 or SPE-2 105°C (221°F) flexible cord is to be provided as an interconnection between two or more portable cabinet lights intended for use in a single cabinet.

83.2.2 An interconnecting cord for portable cabinet lights shall be in accordance with Table 27.1 and rated 105°C minimum.

Exception: For a Class 2 circuit, wire or cord other than specified in Table 27.1 or of a lower temperature rating is able to be used, including appliance wiring material, when the insulation is rated for the maximum temperature and voltage involved.

83.3 Attachment plugs and receptacles

83.3.1 A plug or a receptacle shall be rated not less than 15 A, for portable cabinet lights that are not provided with overcurrent protection.

83.3.2 A portable cabinet light intended for interconnection shall be provided with:

- a) A receptacle of the same type and configuration as the attachment plug of the portable unit, as illustrated in Figure 32.1, and marked in accordance with 175.4; or
- b) A non-NEMA standard receptacle.

83.4 Lampholders

83.4.1 Lampholders shall have all wiring terminations and connections enclosed within the insulating body of the lampholder.

83.5 Low voltage portable cabinet lights

83.5.1 A low voltage portable cabinet light intended for connection to a remote transformer or power supply shall be supplied with a polarized cord and plug assembly attached to the portable luminaire. The power supply is able to be shipped separately, when the portable cabinet light and the transformer or power supply are marked in accordance with 175.2.

83.5.2 The cord between a low voltage portable cabinet light and remote mounted low voltage transformer or power supply shall be 18 inches (457.2 mm) long minimum.

83.5.3 Proprietary plugs and receptacles used for secondary circuit or low voltage connections shall not be NEMA Styles 1 – 15, 1 – 15P, 5 – 15, or 5 – 20.

83.5.4 Low voltage wiring shall have an ampacity rating in accordance with Table 26.1. Overcurrent protection for low voltage wiring is not required.

84 Tests

84.1 Normal temperature test

84.1.1 A portable cabinet light shall be subjected to the Normal Temperature Test, Section 124, General, Section 125, Test Method – General, and Section 127, Specific Test Conditions – Portable Cabinet Lights.

85 Markings

85.1 A portable cabinet light shall comply with the markings specified in Section 175, Portable Cabinet Lights.

85.2 A ten foot detachable cord set provided for use as an accessory with the portable cabinet light shall be marked in accordance with 175.3.

86 Instructions

86.1 A portable cabinet light shall comply with the instructions specified in Section 188, Portable Cabinet Lights.

UNITS FOR USE WITH OFFICE FURNISHINGS – SUPPLEMENTARY

87 General

87.1 The requirements specified in this section apply to portable luminaires used with office furnishing.

87.2 These requirements are supplementary to other applicable requirements in this Standard.

87.3 A portable luminaire intended for use with proprietary mounting systems shall be evaluated based upon the manufacturer's instructions.

88 Construction – Mechanical

88.1 An office furnishing shall not be used to complete any portion of an electrical enclosure.

89 Construction – Electrical

89.1 Power-supply cords

89.1.1 A power supply cord shall be at least hard usage, Type SJ, SJE, SJEO, SJO, SJOO, SJT, SJTO, SJTOO, S, SE, SEO, SO, SOO, ST, STO, or STOO as defined in UL 62, the Standard for Flexible Cord and Fixture Wire.

89.1.2 A power supply cord shall not exceed 9 feet (2.74 m) in length as measured from the back surface of the attachment plug to the point of cord entry on the portable luminaire.

89.1.3 A power supply cord shall be No. 18 AWG minimum, shall contain an equipment grounding conductor, and have a grounding type attachment plug.

Exception: Portable luminaires having a polymeric enclosure and no metal parts accessible during normal use, relamping, or starter replacement is not required to comply with this grounding requirement. Accessible metal parts include ballast mounting screws or metal fasteners that are able to become energized.

89.2 Plugs and receptacles

89.2.1 A plug or receptacle provided for interconnection shall be the grounded type and rated not less than 15 A, 125 V, and shall not be NEMA Styles 1 – 15, 1 – 15P, 5 – 15 or 5 – 20.

Exception: A grounded type plug or receptacle is not required when the portable luminaire complies with the Exception to 89.1.3.

89.2.2 A convenience receptacle shall not be provided in a portable luminaire for use with office furnishings.

89.3 Interconnecting cord

89.3.1 An interconnecting cord shall be the hard usage type rated 105°C in accordance with 89.1.3.

89.3.2 When overcurrent protection is not provided, the interconnecting cord shall be either No.16 AWG when marked in accordance with 169.9.4, or No.14 AWG minimum.

89.4 Overcurrent protection

89.4.1 Overcurrent protection shall be provided for office furnishing type units equipped with a No. 18 AWG power supply cord.

89.4.2 The rating of the overcurrent protective device shall be consistent with the rating of the plugs and receptacles and the ampacity of the power supply cord.

89.4.3 Overcurrent protection in the form of fuses shall have a marking in accordance with 169.9.3.

90 Markings

90.1 An office furnishing type unit shall comply with the markings specified in Section 176, Units for Use With Office Furnishings.

91 Instructions

91.1 An office furnishing type unit shall comply with the instructions specified in Section 189, Units for Use with Office Furnishings.

CONVERTIBLE UNITS – SUPPLEMENTARY

92 General

92.1 The requirements specified in Sections 92 – 96 apply to portable luminaires intended to be convertible to fixed units (lighting fixtures).

92.2 These requirements are supplementary to other applicable requirements in this Standard.

92.3 A convertible unit shall be mounted in accordance with the instructions provided by the manufacturer and evaluated as a portable luminaire in accordance with the requirements in this standard and as a fixed unit (luminaire) in accordance with the Standard for Luminaires, UL 1598.

93 Construction – Mechanical

93.1 Swag-to-chandelier conversion kits

93.1.1 A convertible swag type unit shall be provided with a separately packaged conversion kit, consisting of a canopy, crossbar, wire connectors, and all the required mounting hardware to enable the portable luminaire to be converted to a chain-suspended, outlet box-mounted unit.

93.2 Surface mount conversion kits

93.2.1 A convertible surface-mount unit shall be provided with a separately packaged conversion kit, consisting of wire connectors and all the mounting hardware required, to enable the portable luminaire to be converted to a surface-mount unit.

94 Construction – Electrical

94.1 Grounding

94.1.1 A convertible unit shall have a grounding conductor in accordance with this Standard that complies with the requirements in the Standard for Luminaires, UL 1598, as appropriate.

94.1.2 The grounding conductor provided with a chain suspended (swag) type unit shall either:

- a) Be integral with the power supply cord; or
- b) Extended at least 12 inches (304.8 mm) beyond the last link of chain.

94.1.3 The grounding conductor of a convertible surface-mounted unit shall either:

- a) Be integral with the power supply cord; or
- b) Extend at least 12 inches (304.8 mm) from the exit of the power supply cord from the convertible unit.

94.2 Polarity

94.2.1 A convertible unit shall be wired so that the conductor connected to the screw-shell or to the identified neutral of the ballast is identified for proper connection to the power supply in accordance with Polarization and Identification, Section 35.

95 Markings

95.1 A convertible unit shall comply with the markings specified in Section 177, Convertible Units.

96 Instructions

96.1 A convertible unit shall comply with the instructions specified in Section 190, Convertible Units.

INTERCHANGEABLE UNITS – SUPPLEMENTARY REQUIREMENTS

97 General

97.1 The requirements specified in Sections 97 – 100 apply to residential units which utilize one or more replaceable or interchangeable lighting assemblies fitted to a base which is to be weighted or configured for pin-up mounting.

97.2 These requirements are supplementary to other applicable requirements in this Standard.

97.3 The base, adapter, and lighting assembly shall comply with the applicable requirements of the Standard for Track Lighting Systems, UL 1574.

Exception: A lighting assembly complying with the requirements of UL 1574 is not required to comply with the Normal Temperature Test requirements of Section 124, General, and Section 125, Test Method – General, with respect to shade temperatures when the base for which the lighting assembly is intended is marked in accordance with 178.5.

98 Construction – Mechanical

98.1 Mounting

98.1.1 The base shall not be provided with means for permanent mounting to a building structure. This does not preclude the provision of clips or separable mounting brackets which are intended to be permanently attached to a building structure and to which the base is connected.

Exception: Means for mounting in accordance with Surface Mounted Units, Section 67, General, and Section 68, Wall Mounted Units, is to be provided.

98.1.2 It shall not be required to use a tool to remove the base from clips or separable mounting brackets.

99 Construction – Electrical

99.1 Power-supply cords

99.1.1 The power supply cord and attachment plug cap shall be rated in accordance with Electrical Ratings, 169.6, based on the maximum current rating of the lighting assemblies intended to be applied to the base, in accordance with the marking specified in 178.1.

99.2 Polarization

99.2.1 Polarity shall be maintained electrically through all components (power supply cord, base, adapter and lighting assembly). The screw shell of an Edison-base lampholder and an identified (neutral) conductor of a ballast shall be connected to the grounded (neutral) conductor of the lighting assembly and the base.

99.2.2 The mechanical means required in 99.2.1 for maintaining polarity of the components (for example, a keying ridge or protrusion) shall comply with the Mechanical Means of Polarity Test, Section 160.

99.3 Adapter

99.3.1 The base shall be provided with a fixed number of locations for attachment of adapters.

99.3.2 An adapter shall not be provided with a general purpose receptacle.

100 Markings

100.1 An interchangeable type unit shall comply with the marking specified in Section 178, Interchangeable Units.

TRACK-STYLE UNITS – SUPPLEMENTARY

101 General

101.1 The requirements specified in this section apply to portable luminaires that utilize one or more replaceable or interchangeable lighting assemblies fitted to a track or portion thereof intended to facilitate adjustment.

101.2 These requirements are supplementary to other applicable requirements in this Standard.

101.3 A track-style type unit shall comply with the applicable requirements in this standard. The track and adapter shall comply with the applicable requirements in the Standard for Track Lighting Systems, UL 1574. A lighting assembly complying with the applicable requirements in UL 1574 need not be subjected to further evaluation.

102 Construction – Mechanical

102.1 Track

102.1.1 The track shall be provided in fixed, one piece, lengths with a maximum length of 8 feet (2.4 m) and with the power-supply cord fitter and end cap attached.

102.2 Securement of cord and end cap

102.2.1 The power-supply cord fitter and the end cap shall be permanently secured in place.

102.2.2 With respect to 102.2.1, an end cap or power-supply cord fitter is determined to be permanently secured in place when it is secured in such a manner that it is not removable:

- a) Without the use of tools; or
- b) With ordinary tools such as a flat or cross blade screwdriver, common pliers, or a hex head driver.

Exception: The power-supply cord fitter or end cap is able to be removable (removed) with ordinary tools when the assembly means is not visible after installation.

102.3 Mounting means

102.3.1 Mounting means shall be provided with each track. The mounting means shall consist of:

- a) Screws or bolts for mounting the track; or
- b) Clips for mounting the track along with screws or bolts for mounting of the clips.

Exception: A different mounting means is to be provided when it complies with the Track Clip Securement Test, Section 161, and is investigated and found to be equivalent to the mounting means described in 102.3.1.

102.3.2 Mounting clips, when provided, shall comply with the Track Clip Securement Test, Section 161.

103 Construction – Electrical

103.1 Power-supply cords

103.1.1 The power-supply cord attachment plug and over current protection shall be sized in accordance with Table 103.1. Over current protection shall be provided in the power-supply cord.

Table 103.1
Size of power-supply cord attachment plug and overcurrent protection

Cord size AWG	Minimum plug rating (Amperes)	Maximum ampere overcurrent
12	20	none
12	15	15
14	15	15
16	10	10
18	7	7

103.2 Polarity

103.2.1 Polarity shall be maintained electrically through all components (power-supply cord, power-supply fitter, track, adapter, and lighting assembly) of a track-style type unit.

103.3 Receptacles

103.3.1 A general purpose receptacle shall not be provided.

104 Tests

104.1 Mechanical means of polarity test

104.1.1 The mechanical means required in 103.2.1 for maintaining polarity of the components in a track-style type unit (for example, a keying ridge or protrusion) shall comply with the Mechanical Means of Polarity Test, Section 160.

104.2 Track clip securement test

104.2.1 Mounting clips and the exception to 103.2.1 shall be evaluated by complying with the Track Clip Securement Test, Section 161.

105 Markings

105.1 A track style unit shall comply with the markings specified in Section 179, Track-Style Units.

106 Instructions

106.1 A track style unit shall comply with the instructions specified in Section 191, Track-Style Units.

PORTABLE LUMINAIRE SUBASSEMBLIES – SUPPLEMENTARY

107 General

107.1 The requirements specified in Sections 107 – 112 apply to portable luminaire subassemblies. A subassembly consists of all the parts to a portable luminaire in an easy to assemble form either for "building" a unit (such as a craft kit) or rewiring a unit. They are intended to be assembled by a person presumed to possess a little or no knowledge of electrical circuitry. The assembled units shall comply with the applicable requirements elsewhere in this standard independent of any materials not included in the kit. Only ordinary tools shall be required for assembly unless specific tools are provided.

107.2 These requirements are supplementary to other applicable requirements in this Standard.

108 Construction – Mechanical

108.1 General

108.1.1 The complete subassembly shall be packaged in a single carton or container. This does not preclude shipping cartons holding many of the individually packaged products.

108.2 Shade

108.2.1 When a shade is not provided, then instructions detailing shade dimensions shall be provided in accordance with Incandescent Units Shipped Without Lampshade, 184.1.

109 Construction – Electrical

109.1 General

109.1.1 A portable luminaire subassembly shall consist of all electrical parts (including wire nuts, pre-stripped and tinned wires, and screws for mounting components when required) and either:

- a) The required mechanical support or enclosure parts; and/or
- b) Complete instructing for "building" or "finding" parts that meet the intent of the requirement.

109.1.2 The electrical assembly shall be completely factory wired and the lampholder shall have integral leads or an integral shell that encloses the wiring terminations.

Exception: The electrical assembly is not required to be completely factory-wired where the construction of the kit precludes the pulling of the cord, when:

- a) *The integrity of the strain relief at all factory connections is intact; and*

b) The means of providing and maintaining strain relief and/or proper polarity are clearly detailed in the instructions.

109.2 Power-supply cord

109.2.1 For a unit rewiring subassembly, the minimum power supply cord length shall be such that when the unit is rewired, the external portion of the cord is at least 5 feet (1.5 m) long.

109.3 Mounting of components

109.3.1 A fluorescent unit subassembly is to include a means for supporting the ballast(s) unless the means of support is integral with the lampholder(s).

109.3.2 A cork or plug mounted on a stem connected to the lampholder is an intended means for mounting the lampholder to a bottle, vase, jar, or similar support.

110 Tests

110.1 Assembly and installation test

110.1.1 The portable luminaire subassembly's required assembly and installation instructions shall be evaluated by conducting the Assembly and Installation Test, Section 162.

111 Markings

111.1 A portable luminaire subassembly shall comply with the markings specified in Section 180, Portable Luminaire Subassemblies.

112 Instructions

112.1 A portable luminaire subassembly shall comply with the installation instructions specified in Section 192, Portable Luminaire Subassemblies.

112.2 All parts provided shall be detailed in the assembly instructions.

WORK LIGHTS – SUPPLEMENTARY

113 General

113.1 The requirements specified in Sections 113 – 117 apply to work lights defined in accordance with 2.49.

113.2 These requirements are supplementary to other applicable requirements in this Standard.

113.3 A work light with a tungsten halogen lamp shall additionally comply with the requirements in Tungsten Halogen Units, Sections 51 – 56 unless superseded by requirements herein.

113.4 A work light with a high intensity discharge lamp shall additionally comply with the requirements in High Intensity Discharge Units, Sections 62 – 66 unless superseded by requirements herein.

113.5 A work light marked for outdoor use, in accordance with 181.4, or for wet location use, in accordance with 182.1, shall additionally comply with the requirements in Wet Location Use, Sections 118 – 123 unless superseded by the requirements herein.

114 Construction – Mechanical

114.1 Assembly

114.1.1 A work light is able to be unassembled when the subassemblies comply with Assembly and Packaging, Section 8.

114.1.2 A guard for a work light, when not factory attached, is to be shipped only as a single unattached subassembly when it is able to be attached by common household tools and is marked in accordance with 181.6.

114.2 Guards

114.2.1 A work light shall be provided with a guard that complies with this Section.

Exception: A guard is not required when the housing surface temperatures do not exceed 150°C (302°F) during the Normal Temperature Test, Section 124, General, Section 125, Test Method – General, and Section 128, Specific Test Conditions – Work Lights.

114.2.2 A guard shall be fabricated from nominal 0.06 inch (1.5 mm) minimum diameter plated or painted wire.

114.2.3 For areas other than at the exposed lamp or diffuser, the guard shall prevent a 2 inch (51 mm) diameter sphere from contacting any housing surfaces which require guarding. See Figure 114.1 for sphere probe.

Figure 114.1
Sphere probe for work lights

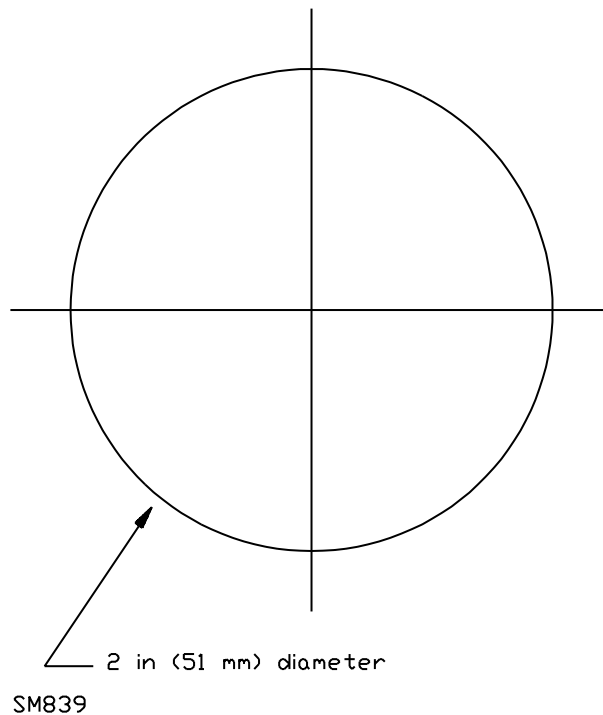

114.2.4 A guard for the lens or diffuser is not required for a work light complying with Exception No. 1 or Exception No. 2 to 116.2.1.

114.2.5 A work light guard shall be attached so that it either:

- a) Requires the use of tools for removal; or
- b) Requires two separate actions to disengage the securing means (i.e. push and turn) and complies with the Guard Securement Test in Section 163.

114.3 Handles

114.3.1 A work light with external enclosure surface temperatures exceeding 90°C (194°F) during the Normal Temperature Test, Section 124, General, Section 125, Test Method – General, and Section 128, Specific Test Conditions – Work Lights, shall be provided with a handle for positioning the light. The surface temperature of the handle shall not exceed the limits in Table 125.1, item 1(b).

Exception: A work light is not required to comply with this requirement when it requires a tool for making aiming adjustments.

114.4 Bases and stands

114.4.1 Work lights have the option of being freestanding, clamp on, or employing similar portable mounting means, or being provided with a means for mounting to a tool, machine, wall, or similar movable object.

114.4.2 A stand that telescopes and extends 5 feet (1.5 m) or more above the ground shall be arranged to prevent sudden collapse when aiming or adjusting the work light. This is to be accomplished by a detent, positive latching or locking feature.

114.4.3 The telescoping portion of a stand shall either have a mechanical stop to prevent separation or have an alignment mark. The product shall be marked in accordance with 181.7 describing the purpose of the alignment mark.

114.4.4 A base or stand that has casters or wheels shall have an integral locking device.

114.4.5 A base or stand of a wet location type unit that has casters or wheels shall have provision for storing the power supply cord.

114.4.6 Stability of a work light shall not rely on a compartment or a base or stand intended to be filled with liquid, sand, or other material by the user or operator.

114.4.7 A base or stand having a liquid fueled motor driven generator shall comply with UL 508, the Standard for Industrial Control Equipment, and UL 1248, the Standard for Engine-Generator Assemblies for Use in Recreational Vehicles.

115 Construction – Electrical

115.1 Power-supply cords

115.1.1 A work light rated 1000 W or less shall be provided with a junior hard service cord Type SJ, SJO, SJT or equivalent rated for the current in accordance with Table 26.1.

115.1.2 A work light rating exceeding 1000 W shall be provided with a hard service cord Type S, SO, ST or equivalent rated for the current in accordance with Table 26.1.

115.1.3 A power supply cord shall not exceed 50 feet (15 m) in length.

115.1.4 A work light power supply cord shall be routed or secured such that normal adjustment of the light does not result in the power supply cord resting on a surface having a temperature greater than the cord rating.

115.2 Grounding type attachment plug

115.2.1 A work light having accessible metal surfaces that becomes energized due to electrical fault shall have a grounding type attachment plug.

115.2.2 A work light provided with a receptacle shall have a grounding type attachment plug.

115.3 Receptacles

115.3.1 A work light receptacle shall:

- a) Be of the grounding type; and
- b) Comply with applicable receptacle requirements in Receptacles, Section 43.

115.3.2 A single or duplex receptacle shall be determined to have a 15 ampere load for the purposes of determining the AWG of the power supply cord and rating of the attachment plug. Alternatively, the marked maximum current rating is able to be used. See 169.6.3.

115.4 Tipover switches

115.4.1 When a tipover switch is provided, the Severe Condition Test, 143.3 is not required.

115.4.2 A tipover switch shall comply with Switches and Dimmers, Section 42.

115.4.3 A tipover switch shall de-energize the work light when tipped over in any direction.

115.4.4 A tipover switch shall be arranged such that the trip mechanism is not able to be externally defeated or result in nuisance tripping. A plunger activated switch where the weight of the work light activates the light source does not meet the intent of the above requirement.

115.5 Integral power supplies

115.5.1 A work light provided with an integral power supply, such as a motor generator, shall comply with the wet location requirements unless superseded by the requirements herein.

115.5.2 A work light provided with an integral power supply is not required to be provided with a guard, in accordance with Guards, 114.2, when the lamp is located at least 5 feet (1.5 m) above the ground in its lowest position.

115.5.3 A work light provided with an integral power supply shall be marked in accordance with 181.4 and restricted to outdoor use only.

116 Tests

116.1 Normal temperature test

116.1.1 A work light shall be subjected to the Normal Temperature Test, Section 124, General, Section 125, Test Method – General, and Section 128, Specific Test Conditions – Work Lights.

116.2 Tungsten-halogen unit tests

116.2.1 A tungsten-halogen type work light is to be subjected only to the following tests in Sections 143 – 151:

- a) Polymeric Lamp Containment Barrier Test, Section 150;
- b) Severe Condition, 143.3 and 143.8; and
- c) Tungsten-Halogen Lamp Guard, Lamp Containment Barrier, and UV Filter Security Tests, Section 144.

Exception No. 1: The Severe Condition Test, 143.3 and 143.8, is not required to be performed when a tipover switch is provided in accordance with Tipover Switches, 115.4.

Exception No. 2: The Severe Condition Test, 143.3 and 143.8, and the Tungsten-Halogen Lamp Guard, Lamp Containment Barrier, and UV Filter Security Tests, Section 144, are not required to be performed when the unit complies with 116.3.2 and is marked in accordance with 181.4.

116.3 Stability tests

116.3.1 A work light is to be subjected to the Stability Test, Section 132, at an incline of 8 degrees for any possible use adjustment.

116.3.2 A work light complying with Exception No. 2 of 116.2.1 is to be subjected to the Stability Test, Section 132, at an incline of 33 degrees.

116.3.3 The stability test in 116.3.1 and 116.3.2 is to be conducted with any fuel and integral storage compartments empty.

117 Markings

117.1 A work light shall comply with the markings specified in Section 181, Work Light.

WET LOCATION USE – SUPPLEMENTARY

118 General

118.1 The requirements specified in Sections 118 – 123 apply to surface-mounted, free standing, or stake mounted units marked "Suitable for wet locations." Such portable luminaires are suitable for locations subject to rain, vehicle washing areas, locations subject to spray of a noncorrosive and nonflammable liquid, and similar conditions.

118.2 These requirements are supplementary to other applicable requirements in this Standard.

118.3 The requirements do not cover portable luminaires for use under water (such as in a decorative fountain or a swimming pool) nor in areas that contain flammable or corrosive liquids or gases.

119 Construction – Mechanical

119.1 Enclosure

119.1.1 A portable luminaire shall be constructed to prevent the accumulation of water on live parts, electrical components, or conductors not identified for use in contact with water.

119.1.2 A polymeric material used as an enclosure for wet location use units shall have an ultraviolet light (UV) resistance rating in accordance with the Standard for Polymeric Materials – Use in Electrical Equipment Evaluations, UL 746C.

119.2 Water shields

119.2.1 A polymeric water shield shall be a UV rated material.

119.2.2 A polymeric water shield that operates at a temperature higher than 65°C (117°F), but not higher than 95°C (171°F), as determined by Normal Temperature Test of Section 125, Test Method – General, and that does not have a recognized temperature rating for the measured temperature shall comply with the Thermal Conditioning Test of Section 165, Polymeric Thermal Conditioning Test.

119.3 Corrosion protection

119.3.1 Copper, aluminum, and alloys of copper and aluminum, stainless steel, and similar materials having inherent resistance to atmospheric corrosion may be used without additional corrosion protection.

119.3.2 All exposed, exterior and interior, surfaces of ferrous metal parts shall be protected by one of the following:

- a) A coating of nonferrous metal applied by the hot dip process method;
- b) A plating of nonferrous metal applied either by electro-deposition or by chemical means;
- c) A coating of vitreous enamel;
- d) Baked paint, or similar type of coating; or
- e) Air-dry paint that complies with the Paint Adhesion Test of Section 168.

119.3.3 The requirements of 119.3.2 shall not apply to the following:

- a) Bearings, sliding surfaces of a hinge or shaft, hinge pins, and similar parts located on the exterior of enclosures where such protection is not practical; and
- b) Decorative parts.

119.3.4 Edges, punched holes, and spot-welds in prefinished steel, and hanger locations for painting or plating in ferrous metal, do not require any corrosion protection.

119.3.5 Welds in ferrous metals shall be painted with at least one coat of outdoor paint, and spot-welds in galvanized steel shall be painted with at least one coat of paint.

119.3.6 Vitreous enamels are able to be used as a protective coating for ferrous sheet metal having a minimum thickness of 0.025 inch (0.6 mm).

119.4 Drain openings

119.4.1 A portable luminaire that permits water to enter the unit during the Rain and Sprinkler Tests, Section 164, shall be provided with a drain hole.

119.4.2 Drain holes, if provided, shall be located in the surface likely to prevent the accumulation of water.

119.4.3 Drain holes shall permit the insertion of a 0.125 inch (3.2 mm) diameter rod.

119.5 Gaskets

119.5.1 A gasket or bushing required to prevent water from entering the enclosure shall be secured to prevent its loosening during user maintenance by a clip, clamping ring, adhesion, or other mechanical means.

119.5.2 A gasket shall be made of material as shown in Table 125.1, Items 24 – 29, and shall have a temperature rating suitable for the operating temperature as determined by the Normal Temperature Test of 125.1, or shall withstand the:

- a) Gasket Accelerated Aging Test of Section 166, Test Method A, for the gasket or bushing only; or
- b) Gasket Accelerated Aging Test of Section 166, Test Method B, with the gasket or bushing installed as intended in the portable luminaire.

119.5.3 The adhesive used to secure a gasket or bushing that is required to prevent water from entering the enclosure, and which is likely to be exposed or not compressed as intended during user maintenance, shall comply with the:

- a) Gasket Adhesion Test of Section 167, method A for the gasket adhesive combination only; or
- b) Gasket Adhesion Test of Section 167, method A, with the gasket installed in the portable luminaire.

119.6 Mounting stakes

119.6.1 Mounting stakes for wet location type units shall be 5 – 9 inches (12.7 – 22.9 cm) long. Shorter stakes or multiple stakes are permitted when the portable luminaire is provided with a stabilizing plate 3 inches (7.6 cm) minimum in diameter perpendicular to the stake.

119.6.2 Mounting stakes shall be provided with at least one reinforcing angle running the length of the stake.

119.6.3 Mounting stakes shall be:

- a) 0.056 inch (1.42 mm) thick minimum zinc coated steel;
- b) 0.1 inch (2.5 mm) thick minimum diecast aluminum, or sheet aluminum; or
- c) 0.1 inch (2.5 mm) thick minimum rigid plastic complying with the requirements in Polymeric Enclosures, Section 12.

120 Construction – Electrical

120.1 Power-supply cords

120.1.1 Any cord exposed outside of a portable luminaire shall be type SJ, SJO, SJT, or equivalent and be marked "W" following the type designation.

120.1.2 The maximum cord length shall be 50 feet (15.2 m).

120.2 Grounding type attachment plug

120.2.1 Wet location units having accessible metal surfaces that become energized due to electrical fault shall have a grounding type attachment plug.

120.3 Receptacles

120.3.1 A portable luminaire provided with a convenience receptacle shall be provided with a self-closing cover.

120.3.2 A portable luminaire provided with a connector or receptacle intended for interconnection of additional lighting units shall be constructed to prevent the entrance of water into the connector with or without a protective cover or attachment plug in place.

120.3.3 A wet location unit with a receptacle shall be provided with a Class A ground-fault circuit-interrupter (GFCI) with open neutral protection.

120.4 Lampholders

120.4.1 The screw shell in a screw shell-type lampholder shall not be constructed of unplated aluminum.

120.5 Switches

120.5.1 A switch shall be arranged to prevent water from entering the switch or enclosure.

120.6 Electrical insulation

120.6.1 Nonabsorptive electrical insulation shall be used in the construction of electrical components where it is relied upon to provide electrical spacings or sole support of live electrical parts or to provide electrical insulation. Untreated fiber and similar material shall not be used; while treated cellulosic fiber, phenolic, urea, porcelain, and similar material, are examples of materials that meet the intent of the requirement.

121 Tests

121.1 Wet location tests

121.1.1 A wet location type unit shall be subjected to the Wet Location Use Tests, Sections 164 – 168 as applicable.

122 Markings

122.1 A wet location type unit shall comply with the markings specified in Section 182, Wet Location Use.

123 Instructions

123.1 A wet location type unit shall comply with the instructions specified in Section 193, Wet Location Use.

PART II

PERFORMANCE

GENERAL – NORMAL TEMPERATURE TEST

124 General

124.1 A portable luminaire shall be subjected to a normal temperature test in accordance with the following:

- a) Freestanding and Surface Mounted Units – Shall be tested in accordance with Sections 124 – 126.
- b) Portable Cabinet Lights – Shall be tested in accordance with Section 124, General, Section 125, Test Method – General, and Section 127, Specific Test Conditions – Portable Cabinet Lights.
- c) Work Lights – Shall be tested in accordance with Section 124, General, Section 125, Test Method – General, and Section 128, Specific Test Conditions – Work Lights.

124.2 A temperature test is not required for portable luminaires that comply with the temperature test exempt requirements for:

- a) Incandescent units specified in Section 47, Temperature Test-Exempt Units,
- b) Tungsten-halogen units using medium base Type A lamps specified in 54.1.2, and
- c) Fluorescent units specified in Section 60, Temperature Test-Exempt Units.

124.3 A portable luminaire that requires evaluation under any other part of this standard requires temperature testing in accordance with the particular part.

124.4 A temperature test conducted with an aluminum shade shall not be used to represent a steel shade. A temperature test conducted with a light colored or reflective shade shall not be used to represent a dark colored or nonreflective shade. A temperature test conducted with a phenolic or porcelain lampholder in the base-up position shall not be used to represent a metal shell lampholder.

125 Test Method – General

125.1 Temperature limits

125.1.1 The temperature limits specified in Table 125.1 are based on an ambient temperature of 25°C (77°F). The temperature test is to be conducted at any ambient temperature between 20 and 30°C (68 and 96°F) and corrected to an ambient of 25°C (77°F).

125.1.2 A polymeric material used as a decorative trim or part shall not melt or deform in such a way as to interfere with the normal operation of the lamp.

Table 125.1
Maximum temperatures

Parts and materials		Temperature	
		°C	°F
1.	Accessible parts (see also Item 18)		
A.	Portable luminaire external surfaces (other than lamps or lenses) ^g	90	194
B.	Operating knobs, handles, and levers intended for momentary contact during adjustment only: ^k		
1.	Wood	90	194
2.	Plastic or rubber ^h	85	185
3.	Glass, porcelain, or vitreous enameled material	70	158
4.	Metal	50	122
C.	Handles or surfaces intended to be grasped for lifting, carrying, or holding:		
1.	Metallic	50	122
2.	Nonmetallic	60	140
2.	Work light surfaces (other than diffuser or exposed lamp) without guard ^l	150	302
3.	Capacitors ^a		
A.	Electrolytic	65	149
B.	Other types	90	194
4.	Coil of device employing Class 105 insulation system		
	Thermocouple method	90	194
	Resistance method	100	212

Table 125.1 Continued on Next Page

Table 125.1 Continued

Parts and materials		Temperature	
		°C	°F
5.	Coil of device employing Class 130 insulation system		
	Thermocouple method	110	230
	Resistance method	120	248
6.	Coil of device employing Class 155 insulation systems:		
	Thermocouple method	135	275
	Resistance method	140	284
7.	Coil of device employing Class 180 insulation systems:		
	Thermocouple method	150	302
	Resistance method	165	329
8.	Coil of device employing Class 200 insulation systems:		
	Thermocouple method	170	338
	Resistance method	185	365
9.	Coil of device employing Class 220 insulation systems:		
	Thermocouple method	185	365
	Resistance method	200	392
10.	Coil of device employing Class 250 insulation systems:		
	Thermocouple method	215	419
	Resistance method	230	446
11.	Conductor with rubber or thermoplastic insulation ^b	60	140
12.	Fuses ^b	90	194
13.	Enclosure interior surfaces		
	A. Wood	90	194
	B. Insulating material	c	c
14.	Insulating material		
	A. Polymeric	c	c
	B. Varnished cloth	85	185
	C. Fiber ^b	90	194
	D. Wood and similar material	90	194
	E. Laminated phenolic composition ^b	125	257
	F. Phenolic composition	150	302
15.	Sealing compound	d	d
16.	Semiconductor device ^b	100	212
17.	Surfaces that are able to be adjacent to the portable lamp when it is mounted	90	194
18.	Exterior of wall or ceiling mounted lamps except lamps and lenses ^f	90	194
19.	Phenolic lampholder body ^b	150	302
20.	Lampholder screw shell ^e	200	392
21.	Current carrying parts		
	A. Copper or copper alloy	200	392
	B. Aluminum	200	392
	C. Stainless steel, monel, nickel plated copper	250	482
22.	Required label materials	i	i
Wet Location Units			
23.	On thermoplastic watershields ^{i,b}	65	149
24.	On gaskets of silicone rubber ^j	230	446
25.	On gaskets of EPDM ^j	90	194
26.	On non-thermal setting sealing compound ^j	d	d
27.	On rubber gaskets ^j	70	158

Table 125.1 Continued on Next Page

Table 125.1 Continued

Parts and materials	Temperature	
	°C	°F
28. On neoprene gaskets ^l	90	194
29. On gaskets of cork or other fibrous material ^l	90	194
<p>^a A capacitor operating at a temperature higher than 65°C (149°F) is to be judged on the basis of its marked temperature rating or, when not marked with a temperature rating, is able to be investigated to determine whether it is usable at a higher temperature.</p> <p>^b Does not apply when investigated and found to meet the requirement for a higher temperature.</p> <p>^c Polymeric material shall be judged with respect to the temperature specified for the application.</p> <p>^d The maximum intended sealing compound temperature, when corrected to 25°C (77°F) ambient temperature, is 15°C (27°F) less than the softening point of the compound as determined by the Standard Test Method for Softening Point by Ring-and-Ball Apparatus, ASTM E28-1967(1982).</p> <p>^e Unless it is nickel plated.</p> <p>^f The temperature is able to be higher than 90°C (194°F), and no higher than 150°C (302°F) when the unit is marked as specified in 169.8.</p> <p>^g Where the lens is not also serving as a portion of the shade.</p> <p>^h Includes plastic with a metal plating not more than 0.005 inch (0.13 mm) thick; and metal with a plastic or vinyl covering not less than 0.005 inch (0.13 mm) thick.</p> <p>ⁱ Label materials shall be judged with respect to the temperature intended for the application.</p> <p>^j Applicable only for materials used in wet locations in compliance with 119.5.</p> <p>^k Work light handles are intended for momentary contact during adjustment only.</p> <p>^l Does not apply to work lights complying with 115.5.2.</p>		

125.2 Test duration

125.2.1 A portable luminaire is to be operated continuously at rated lamp wattage until constant temperatures are attained. A motor or other component is to be on and operating at maximum load during the temperature test. A temperature is determined to be constant when:

- a) The test has been running for at least 3 hours; and
- b) Three successive readings, taken at 30-minute intervals, are within 1°C of one another and are still not rising.

125.3 Temperature measurement by thermocouple

125.3.1 When temperature readings are to be obtained by means of thermocouples, the thermocouples shall consist of wires not larger than No. 24 AWG (0.21 mm²). When thermocouples are used in the determination of temperatures in connection with the heating of electrical devices, it is common practice to use thermocouples consisting of No. 30 AWG (0.05 mm²) iron and constantan wire, and an instrument specifically designed for accurate determination of the attained temperature; and such equipment is to be used whenever referee temperature measurements are required. The thermocouple wire is to conform with the requirements specified in the Initial Calibration Tolerances for Thermocouples table in Temperature Measurement Thermocouples, ANSI/ISA MC96.1.

125.3.2 A thermocouple junction and the adjacent thermocouple lead wire are to be held securely in thermal contact with the surface of the material of which the temperature is being measured and shall be placed at locations of the hottest accessible parts. Thermocouples are to be secured to surfaces by welding, soldering, fuller's earth and sodium silicate (waterglass), adhesive intended for surface and temperatures, or equivalent as long as solid thermal contact is maintained. Tape is not to be used to secure the thermocouple within 3 inches (76.2 mm) of the thermocouple junction.

125.3.3 When a portable luminaire utilizes a polymeric part such as a thermoplastic enclosure, watershield, lens, diffuser, or similar parts temperatures are to be measured by placing one or more thermocouples in contact with the part in such a manner that the thermocouple is wedged between the part and any metallic material or other source of conducted heat. For a source of radiated or convected heat, thermocouples are to be inserted from the outside surface through holes drilled in the polymeric material, such that the thermocouple tips are located in the plane of the inside surface and are sealed in place with fuller's earth and sodium silicate (waterglass).

125.3.4 Pleated or double-walled fabric or plastic shades shall have the thermocouples attached by slitting the outer covering and attaching the thermocouples to the outside of the shade liner.

125.4 Temperature measurement by change-of-resistance

125.4.1 The temperature of a coil or winding of a ballast or transformer employing a Class 130 or higher insulation system is to be measured by means of the change-of-resistance method. For a potted device, it is usually required to have a portable luminaire made up with test leads brought out before it is potted, as well as having a thermocouple placed on the capacitor (when provided).

125.4.2 At a point on the surface of a coil of a ballast where the temperature is affected by an external source of heat radiation (for example, a lamp), the temperature rise measured by means of thermocouples mounted on the outside of the coil wrap is able to be greater than the indicated maximum when the temperature rise of the coil, as measured by the resistance method, is not greater than specified in Table 125.1. The maximum temperature differential meeting the intent of the requirement for the thermocouple method is 20°C (36°F).

125.4.3 The temperature rise of a winding is to be calculated by the following formula:

$$T_H = \frac{R_H}{R_C} [k + T_1] - [k + T_2]$$

in which:

T₁ is the temperature of the coil in degrees C when *R_C* is measured;

T_H is the temperature rise of the coil in degrees C at the end of the test;

R_H is the resistance of the coil at the end of the test;

R_C is the resistance of the coil at the beginning of the test;

T₂ is the room temperature at the end of the test in degrees C; and

k is 234.5 for copper or 225.0 for electrical conductor grade (EC) aluminum. Values of the constant for other grades must be determined.

125.4.4 Usually it is required to de-energize the winding before measuring R. The value of R at the end of the test is to be determined by taking several resistance measurements at short intervals, beginning as quickly as possible after the instant of shutdown. A curve of the resistance values versus time is to be plotted and extrapolated to give the value of R at the end of the test.

125.5 Ambient temperature measurement

125.5.1 The ambient temperature is to be measured by means of a thermocouple immersed in a bath of 15 milliliters of mineral oil in a glass container. The oil bath is to be placed:

- a) At the same level as the horizontal plane formed by a line that passes through the portable luminaire halfway down its vertical length; and
- b) At least three unit diameters from the product horizontally.

125.6 Test voltage, current, and wattage

125.6.1 A portable luminaire that uses a lamp rated for other than the voltage it operates at in the product is to be tested in the manner that results in a maximum temperature rise, either at rated voltage or rated wattage. For example, a nominal 120 volt, 60 watt product intended for use with a lamp rated for 130 volts, 60 watts usually operates hotter at rated wattage. Conversely, a nominal 120 volt, 60 watt product intended for use with a lamp rated for 110 volts, 60 watts usually operates hotter at rated voltage.

125.6.2 A portable luminaire provided with a transformer, a ballast, a power supply, or another device that alters the characteristics of the power supply prior to the lamp is to be tested at rated voltage.

125.7 High intensity discharge lamp nominal test conditions

125.7.1 When subjected to a temperature test, a high intensity discharge (HID) type unit shall be provided with a nominal system consisting of a ballast, capacitor, and lamp combination that complies with 125.7. A unit is to be operated at rated frequency and at:

- a) A supply voltage rated for the ballast; or
- b) The supply voltage required to be determined a nominal system in accordance with 125.7.2.

Exception: A nominal system is not required when the portable luminaire is provided with a self-ballasted lamp.

125.7.2 A nominal system shall be a combination of components such that, when connected to the supply voltage rated for the ballast and measured as specified in 125.7.3, the lamp operates at its marked wattage rating ± 5 percent. The capacitance of the capacitor is to be within ± 5 percent of the capacitance rated for the ballast.

Exception: A lamp is not required to operate within ± 5 percent of its marked rating when operated by a ballast intended to operate the lamp at other than the lamp's marked rating. Such a construction is to be documented by the ballast manufacturer.

125.7.3 To determine whether a ballast, capacitor, and lamp combination is a nominal system, the components are to be installed in a portable luminaire and the unit is to be operated in a $25 \pm 5^\circ\text{C}$ ($77 \pm 9^\circ\text{F}$) ambient temperature while connected to a rated supply voltage source. A nominal system exists when the measured lamp wattage after the wattage stabilizes (usually within 15 minutes) is within ± 5 percent of the marked rating of the lamp. Otherwise, to be determined a nominal system, the ballast supply voltage is adjusted so that the lamp operates at the marked lamp wattage.

125.8 Incandescent test lamps

125.8.1 An incandescent type unit is to be tested with a test lamp of the wattage and type marked. When intended for a three-way lamp holder, a three-way lamp is to be used and operated at the highest wattage setting whether marked otherwise or not.

125.8.2 When the marked lamp replacement is of a wattage and type other than specified in Table 125.2 and is a candelabra-, intermediate-, or medium-base type, the test is to be repeated with a test lamp from Table 125.2 that most closely approaches the marked lamp.

Table 125.2
Commonly available lamps

Medium-base lamps	
Wattage	Types
7-1/2, 9	S-11
10, 11	S-14
15	A-15, C-11, S-11, T-10
20	A-17, C-11
25	A-15, A-19, B-13, BA-9-1/2, C-11, C-15, CA-9, F-15, G-18-1/2, G-30, G-40, GT-19, R-17, T-10, T-21
30	A-15, R-20
40	A-15, A-19, A-21, B-13, BA-9-1/2, C-11, C-15, F-15, G-25, G-30, G-40, T-8, T-19
50	A-19, ER-30, R-20, R-30, T-10
60	A-19, A-21, BA-9-1/2, C-11, C-15, CA-9, F-15, G-25, G-30, G-40, GT-19, T-10, T-19
70	A-19, T-19
75	A-19, A-21, E-17, ER-30, G-40, R-20, R-30, R-40, T-10, T-19
90	A-19, A-21
100	A-19, A-21, A-23, G-40, PS-30, R-20, R-30, R-40, T-8-1/2, T-10, T-19
120	ER-40, R-40
150	A-21, A-23, A-25, G-40, P-25, PS-25, R-40, T-10
200	A-21, A-23, A-25, P-25, PS-25, PS-30, PS-35, R-40, T-21
250	G-30, P-25, T-14
300	PS-25, PS-30, R-40
Medium-base 3-way lamps	
Wattage	Types
15-135-150	A-21, T-19
30-70-100	A-21, T-19
50-100-150	A-21, T-19
50-200-250	A-23, T-21
100-200-300	PS-25
Intermediate-base lamps	
Wattage	Types
6	S-6
7	R-12
10	S-11
15	F-10, T-7, T-8
20	T-6-1/2
25	R-12, R-14, S-11, T-6-1/2, T-8

Table 125.2 Continued on Next Page

Table 125.2 Continued

40	S-11, T-6-1/2
Candelabra-base lamps	
Wattage	Types
2	B-10, CA-8
3	S-6
4,7	C-7
6	S-6, T-4-1/2
10	B-12, C-7, G-16-1/2, S-6, S-11
12	B-10
15	B-10, BA-9, C-9-1/2, CA-8, F-10, G-16-1/2, S-11, T-6, T-7, T-8
20	B-10
25	B-10, B-10-1/2, BA-9, C-9-1/2, C-11, CA-10, F-10, G-16-1/2, S-11, ST-9-1/2, T-8
40	B-10, B-10-1/2, BA-9, C-11, CA-10, G-16-1/2, ST-9-1/2
60	B-10, B-10-1/2, BA-9, C-11, CA-10

125.9 Tungsten-halogen test lamps

125.9.1 A tungsten-halogen type unit is to be tested with a test lamp of the wattage and type marked.

125.10 Fluorescent test lamps

125.10.1 A fluorescent type unit is to be tested with a test lamp of the wattage and type marked except as noted in 125.10.2.

125.10.2 A portable luminaire that uses fluorescent lamps with integral starters shall be tested with the lamp(s) that produces maximum heating. This requires a test with the lamp which produces the highest current as well as the lamp which produces the highest wattage.

125.11 High intensity discharge test lamps

125.11.1 A high intensity discharge (HID) unit is to be tested with a test lamp of the wattage and type marked.

125.12 Shade positions and decorative parts

125.12.1 A portable luminaire that is able to be adjusted to several positions of usage shall be tested in the (each) position that results in a maximum temperature rise. This requires testing in more than one position, such as shade horizontal, 45 degrees below horizontal, and vertically down.

125.12.2 A portable luminaire with multiple shades is to be tested in each position that results in a maximum temperature rise on any surface subject to temperature limits in accordance with Table 125.1. The positions used are to represent reasonable positions of use. No shade is to be placed in a position in which the path of light from the shade is obstructed by another shade. Shades are to be tilted, raised, lowered, rotated, or otherwise adjusted as permitted.

125.12.3 A portable luminaire with a shade that clips onto a lamp or a shade supported by a harp shall be tested in any position allowed by the clip on harp adjustments unless compliance with 47.4.1 is established.

125.12.4 A portable luminaire that is provided with an optional or decorative part is to be tested both with and without the part in place when the temperatures on the unit vary, depending on the presence of the part. For example, a metal shade provided with a plastic baffle that extends up over the shade is to be tested with and without the baffle to determine maximum shade temperatures on the metal shade surface. Actuating or moveable parts are to be positioned in any position of normal use, including closing hinged covers ("barn doors").

126 Specific Test Conditions – Free Standing and Surface Mounted Units

126.1 General

126.1.1 Free standing units shall be tested on a level sheet of 1/2 inch (12.7 mm) thick plywood that extends beyond the lamp at least 2 feet (61 cm) in each direction, and is located at least 3 feet (91.4 cm) away from other horizontal or vertical surfaces.

126.1.2 Portable luminaires intended for attachment to a vertical surface, under a cabinet or shelf, or on a ceiling shall be attached to a sheet of 1/2 inch (12.7 mm) thick plywood that extends beyond the lamp at least 2 feet (61 cm) in each direction. The units shall be attached in the worst case position(s) permitted by the manufacturers' directions.

126.1.3 When a portable luminaire has a flexible or adjustable arm, the bottom of the shade or guard shall be positioned parallel to the mounting surface and located as close as possible to the mounting surface, but not closer than 6 inches (152 mm).

Exception: When the unit is unable to comply with 126.1.3 because the arm is not long enough for the shade or guard to maintain a 6 inch (152 mm) spacing, the bottom portion of the shade or guard is to be positioned as close to the mounting surface as permitted by the construction without guiding or propping.

126.2 Test results

126.2.1 Results of the tests meet the intent of the requirement when:

- a) Temperatures do not exceed the applicable values specified in Table 125.1; and
- b) Temperatures on the mounting surface do not exceed 90°C (194°F).

127 Specific Test Conditions – Portable Cabinet Lights

127.1 Other than pot style

127.1.1 The portable cabinet light shall be tested while totally enclosed in a six-sided box having inside dimensions of 12 inches (30 cm) by 12 inches (30 cm) by 12 inches (30 cm). When the length of the portable cabinet light exceeds 12 inches (30 cm), the inside dimension of the test box shall be adjusted to the length of the portable cabinet light. Alternately, the test box is able to have dimensions in accordance with 188.2.1. The test box is to be made of 1/2 inch (12.7 mm) thick plywood or particle board, with a 1/8 inch (3.2 mm) thick glass front. All seams shall be sealed with tape or the equivalent to restrict air exchange.

127.1.2 A portable cabinet light that is completely within the cabinet as shown in Figure 127.1 is to be mounted as close to the sides and top of the test box as the housing or shade provided with the portable cabinet light permits and operated until all temperatures stabilize. If the mounting means accommodates more than one mounting configuration, the test shall be conducted in the condition representing the most severe operation. Alternately, the portable cabinet light is to be mounted in the dimensioned test box as it would be in a cabinet in accordance with the instructions provided with the portable cabinet light and operated as above. The test is to be conducted with the portable cabinet light mounted vertically (lamp base up) and horizontally (side or wall mounted). Portable cabinet lights with adjustable mounting flanges shall be evaluated with the light in representative worst case positions.

Figure 127.1
Portable cabinet light test box

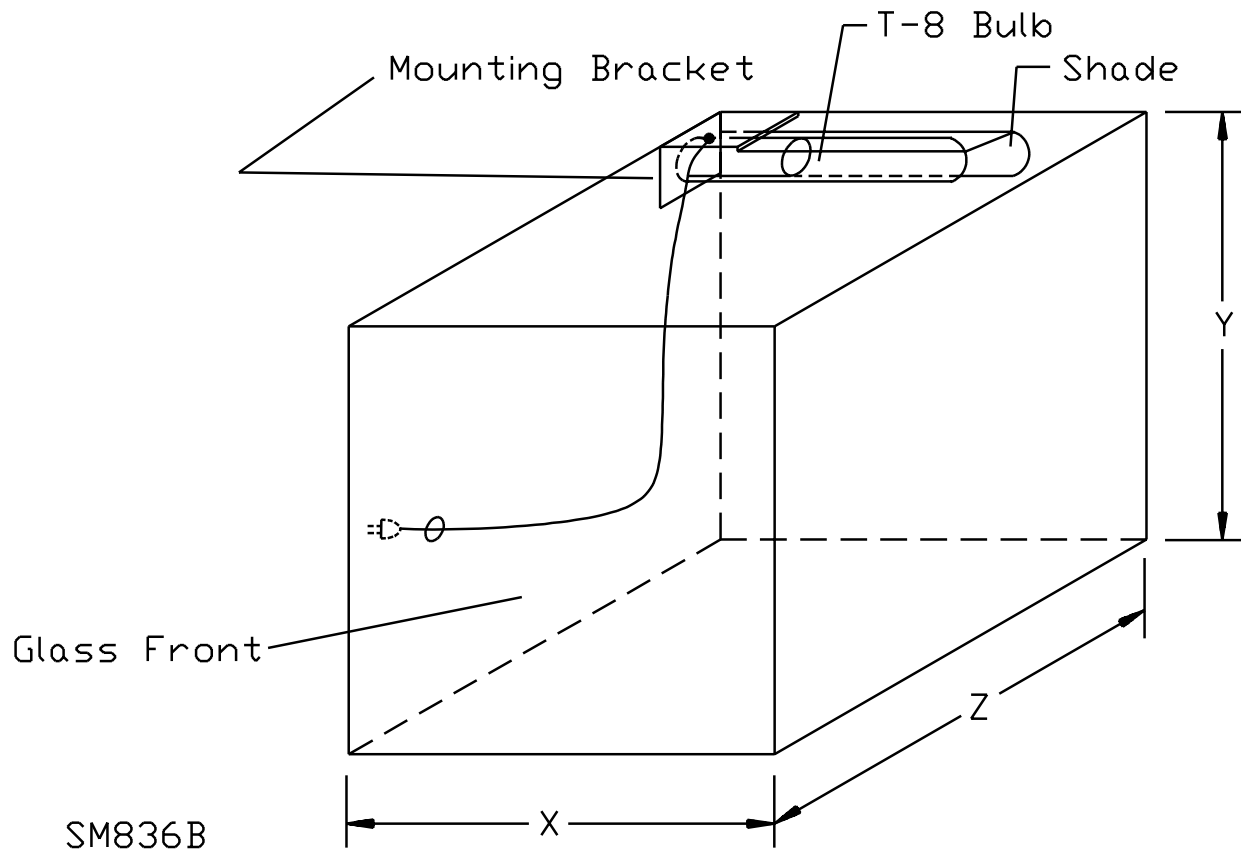

Notes:

- Inside dimensions of test box $X = Y = Z = 12$ inches (30.5 cm) or as specified by manufacturer.
- Seal all openings and seams with tape.
- Position portable cabinet light as close to sides and top as possible.
- Tested with T-8 lamp horizontal and repeated with T-8 lamp vertical, base-up.

127.2 Pot style

127.2.1 A pot style portable cabinet light shall be tested inside the enclosure shown in Figure 127.2. The portable cabinet light shall be centered left to right and with clearances from the pot to the back either provided by the mounting flange or 1/2 inch (12.7 mm), whichever is greater. The clearance from the top of the pot housing to the top of the enclosure is 1/2 inch (12.7 mm). The 1/2 inch (12.7 mm) clearance is measured from the pot housing and does not include tabs, bushings, or brackets. A portable cabinet light with adjustable mounting flanges shall be evaluated with the light in representative worst cast positions. Other mounting configurations shall be evaluated when specified in the manufacturers instructions.

Figure 127.2
Pot style portable cabinet light test box

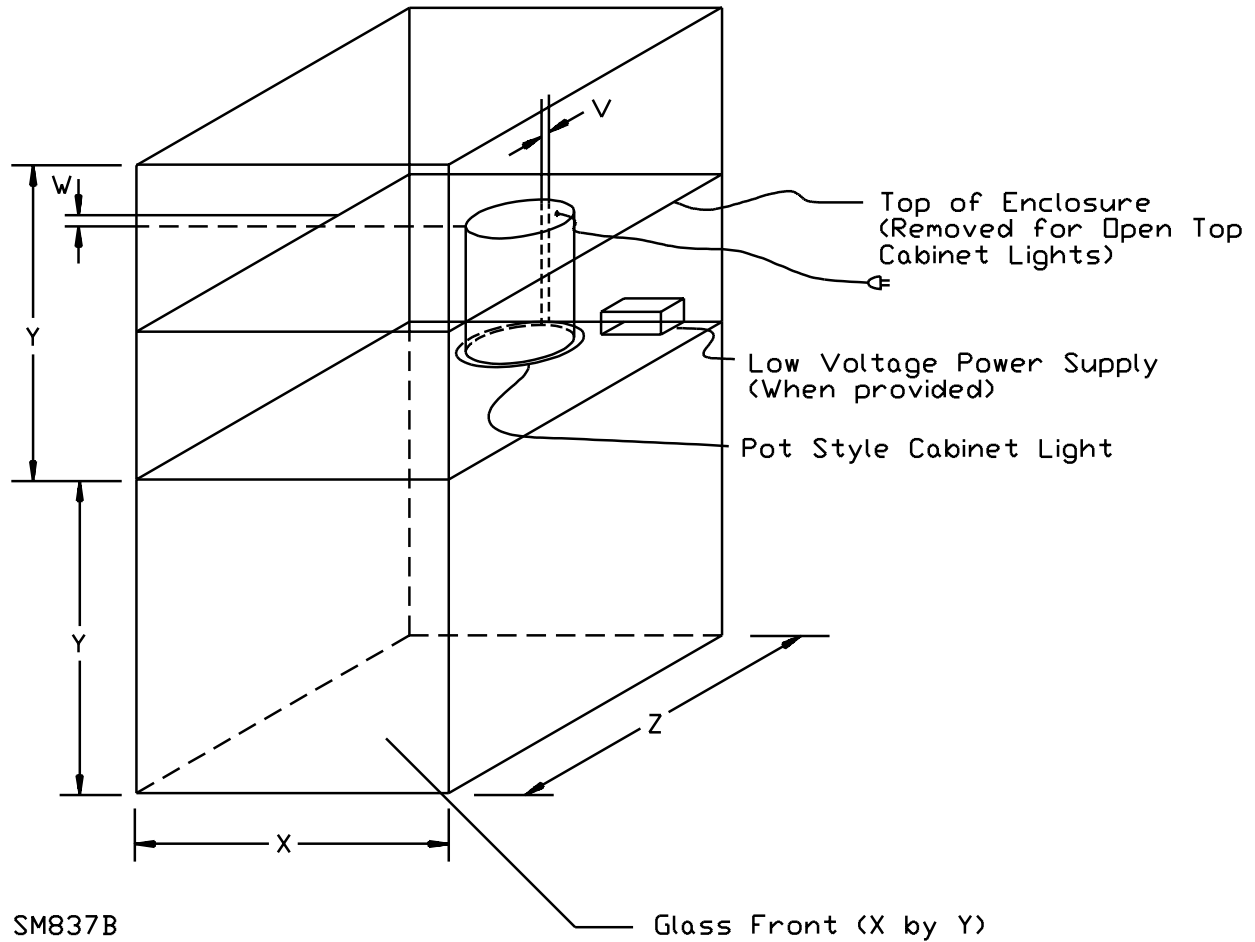

Notes:

- a) Inside dimensions of test box $X = Y = Z = 12$ inches (30.5 cm).
- b) V equals width of pot light mounting flange or 1/2 inch (12.7 mm) spacing from pot light to back of test box, whichever is greater.
- c) Low voltage transformer or power supply mounted as close to the back wall as possible.
- d) W equals 1/2 inch (12.7 mm) from top of pot light to inside of upper box top.
- e) Tested only in position shown.

127.2.2 A pot style portable cabinet light provided with instructions in accordance with 188.2.2 is to be tested with the top of the test enclosure removed with clearances either provided by the mounting flange or 1/2 inch (12.7 mm), whichever is greater. See Figure 127.2.

127.3 Test results

127.3.1 Results of the tests meet the intent of the requirement when:

- a) Temperatures do not exceed the applicable values specified in Table 125.1;
- b) Temperatures on the mounting surface and test box do not exceed 90°C (194°F);
- c) For pot style portable cabinet lights, the maximum temperature on any external surface above the plane of the surface through which the pot style portable cabinet light is mounted shall not exceed 90°C (194°F); and
- d) The housings of remotely mounted transformers or power supplies shall not exceed 90°C (194°F).

128 Specific Test Conditions – Work Lights

128.1 General

128.1.1 A work light is to be temperature tested with the light source adjusted to produce maximum temperatures on the test surface. Multiple temperature tests are to be performed, when required.

128.1.2 When a work light is intended for use with more than one base or stand, each unique configuration is to be evaluated.

128.2 Test results

128.2.1 Results of the tests meet the intent of the requirement when:

- a) Temperatures do not exceed the applicable values specified in Table 125.1; and
- b) Temperatures on the supporting surface under the work light do not exceed 90°C (194°F).

128.2.2 A work light rated less than 150 W shall additionally comply with the 90°C external surface temperature requirements in Table 125.1.

GENERAL – ABNORMAL OPERATION TESTS

129 Adjustable Position or Multiple Shade Abnormal Operation Test

129.1 General

129.1.1 Adjustable or Flexible Shade Position – A portable wall, table or floor type unit that is able to be adjusted such that the shade rests against the supporting surface so as to block the air flow to the lamp is to be tested as described in 129.2 and 129.3.

129.1.2 Multiple Shades – A portable luminaire that is able to be adjusted such that one shade directs light onto another shade is to be tested as described in 129.2 and 129.4. The test is to be conducted in each position that results in a maximum temperature rise on any shade.

129.1.3 Folding Position – A portable luminaire that is able to fold up so as to block the air flow to the lamp is to be tested as described in 129.2 and 129.5.

129.1.4 Compliance criteria is described in 129.6.

129.2 Test method – general

129.2.1 It is usually required to operate the portable luminaire continuously for 7 hours to determine that the ultimate result has been obtained. It is usually required to repeat the tests with each lamp wattage or type used for the Normal Temperature Test, Sections 124 – 128. A new sample is to be used for each test. However, with the concurrence of those concerned, the same sample is to be used for another test provided that results are obtained that meet the intent of the requirement.

129.2.2 An automatic temperature-regulating or -limiting control; or other protective device provided as part of the portable luminaire is to be shunted out of the circuit during the test, unless the control has been shown by an investigation to be reliable and unable to be defeated by the user.

129.2.3 The cloth used in the abnormal test is to be bleached cheesecloth, 36 inches (91.4 cm) wide, running 14 – 15 square yards per pound (26 – 28 m²/kg) and having what is known in the trade as a count of 32 by 28; that is, for any square inch 32 threads in one direction and 28 in the other direction (for any square centimeter, 13 threads in one direction and 11 in the other direction). The cloth is to be loosely draped over the portable luminaire being tested in order to serve as a flame indicator (presence of ash or burnt holes) not as a blanket to trap heat.

129.2.4 The tissue paper used in the abnormal test is to be untreated white paper commonly used for gift wrapping.

129.3 Test method – adjustable or flexible shade position

129.3.1 A portable luminaire is to be supported on white tissue paper on a Knot-free softwood surface with the shade resting against the same surface. The unit is to be loosely covered with a single layer of cloth and operated continuously.

129.3.2 For the purpose of this test, friction alone is not to be relied upon to prevent positioning of a shade against the supporting surface.

129.4 Test method – multiple shades

129.4.1 A portable luminaire is to be placed on a knot-free softwood surface covered with tissue paper. The shades of a unit are to be adjusted such that the light from a shade(s) is focused on another shade(s). The unit is to be covered with a layer of cloth and operated continuously.

129.5 Test method – folding position

129.5.1 A portable luminaire is to be placed in a folded-up position on a knot-free softwood surface covered with tissue paper. The unit is to be loosely covered with a single layer of cloth and operated continuously.

Exception: When the unit is provided with a switch to de-energize the lamp when the lamp is folded, the test is to be conducted at the most severe position permitted by the switch.

129.5.2 For the purpose of this test, friction alone is not to be relied upon to prevent positioning of a shade against the supporting surface.

129.6 Test results

129.6.1 There shall be no:

- a) Emission of flame or molten metal;
- b) Combustion, glowing or flaming or disintegration of the material on which the unit is resting or of material placed on or near the unit;
- c) Exposure of parts involving a risk of electric shock; or
- d) Dielectric breakdown when subjected to the Dielectric Voltage-Withstand Test, Section 137, during any of these tests.

130 Transformer Short-Circuited Test

130.1 General

130.1.1 A portable luminaire using a transformer in accordance with Transformers, Section 44 shall be tested as described in 130.2. Compliance criteria is described in 130.3.

130.2 Test method

130.2.1 The portable luminaire is to be placed in its normal operating position on white tissue paper on a softwood surface, connected to a supply circuit of maximum rated voltage, and operated continuously.

130.2.2 The portable luminaire is to be operated at all voltage settings with each of the following loads, using a new transformer for each test:

- a) The intended lamp;
- b) A load that draws 25 percent of the short-circuit current;
- c) A load that draws 50 percent of the short-circuit current; and
- d) A load that draws 75 percent of the short-circuit current.

130.2.3 The short-circuit current is to be determined by shorting the secondary of the portable luminaire through an ammeter and determining the current after 1 minute of operation of the unit at rated voltage. Any overcurrent-protective device is to be by-passed while the value of the short-circuit current is determined.

130.2.4 The tissue paper used in the abnormal test is to be untreated white paper commonly used for gift wrapping.

130.3 Test results

130.3.1 There shall be no:

- a) Emission of flame or molten metal;
- b) Combustion, glowing or flaming or disintegration of the material on which the unit is resting or of material placed on or near the unit;
- c) Exposure of parts involving a risk of electric shock;
- d) The insulation resistance between exposed metal and live parts normally operating at more than 30 volts shall not be less than 50,000 ohms; or
- e) Dielectric breakdown when subjected to the Dielectric Voltage-Withstand Test, Section 137, during any of these tests.

131 Component Fault Test

131.1 General

131.1.1 A circuit employing an electronic component that requires a component fault test in accordance with 37.3 shall be tested in accordance with 131.2. Compliance criteria is described in 131.3.

131.2 Test method

131.2.1 A circuit involving a capacitor, rectifier, transistor, or similar component involving a risk of fire or electric shock shall be subjected to a component fault test, with the component opened or shorted in accordance with 37.3.

131.2.2 For the test described in 131.2.1, only one component and fault condition is to be conducted per each test.

131.2.3 The portable luminaire is to be placed on a knot-free softwood surface covered with tissue paper. Any dead metal is to be connected through a 3 ampere nonrenewable fuse to either:

- a) Earth ground when the unit is provided with a grounding type attachment plug; or
- b) The neutral conductor when not provided with a grounding type attachment plug.

131.2.4 The unit is to be loosely draped with a single layer of cheese cloth and operated continuously.

131.2.5 It is usually required to operate the unit continuously for 7 hours to determine that the ultimate result has been obtained.

131.2.6 The cloth used in the abnormal test is to be bleached cheesecloth, 36 inches (914 mm) wide, running 14 – 15 square yards per pound (26 – 28 m²/kg) and having what is known in the trade as a count of 32 by 28; that is, for any square inch 32 threads in one direction and 28 in the other direction (for any square centimeter, 13 threads in one direction and 11 in the other direction). The cloth is to be loosely draped over the portable luminaire being tested in order to serve as a flame indicator (presence of ash or burnt holes), not as a blanket to trap heat.

131.2.7 The tissue paper used in the abnormal test is to be untreated white paper commonly used for gift wrapping.

131.3 Test results

131.3.1 There shall be no:

- a) Emission of flame or molten metal;
- b) Combustion, glowing or flaming or disintegration of the material on which the unit is resting or of material placed on or near the unit;
- c) Exposure of parts involving a risk of electric shock; or
- d) Dielectric breakdown when subjected to the Dielectric Voltage-Withstand Test, Section 137, during any of these tests.

GENERAL – MECHANICAL TESTS

132 Stability Test

132.1 General

132.1.1 Freestanding units and units intended for both wall and table support shall be tested as described in 132.2 and as modified in 132.3 when provided with a flexible or articulated arm, or as modified in 132.4 when provided with provisions for loading. Compliance criteria is described in 132.5.

Exception: A portable luminaire intended for placement on a shelf and that complies with the Normal Temperature Test in Sections 124 – 126 in any position and the Drop Test in Section 134 is not required to comply with this requirement.

132.2 Test method – general

132.2.1 The portable luminaire, complete with glassware or shade provided as a part of the lamp or with a representative cloth-and-wire shade when none is provided, is to be placed on the inclined plane and turned to a position that results in tip over. When the shade is supported by an adjustable harp, or clips onto the lamp, it is to be positioned so that the lamp-to-shade spacing is equidistant to the lamp.

132.2.2 The plane is to be inclined at an angle of 8 degrees with the horizontal.

132.2.3 For lamps having toy-like appearance the plane is to be inclined to an angle of 15 degrees.

132.3 Test method – units with flexible or articulated arm

132.3.1 When the portable luminaire has a flexible or articulated arm, the arm is to be bent before the lamp is placed on the inclined plane, starting at the lower end of the arm, to form a quarter circle that a line joining the ends of the arm make an angle of 45 degrees with the horizontal. When a flexible or articulated arm is off-center with respect to the base, the arm is to be bent in the direction that results in tip over. When the unit has more than one flexible or articulated arm, one of the arms is to be adjusted as for a unit having a single arm, and the other arm or arms are to be extended vertically.

Exception No. 1: When the unit is not stable on a flat horizontal surface in a particular position, the unit is not required to be tested in that position.

Exception No. 2: Any position of intended use as specified in the manufacturer's instructions is determined to be the normal operating position.

132.4 Test method – units having provisions for loading

132.4.1 A portable luminaire having one or more of the following:

- a) Off-center shelf;
- b) Adjustable shelf; or
- c) Other provision for loading;

shall comply with the stability test in this section when loaded as described in 132.4.2.

132.4.2 For the stability test of a portable luminaire as described in 132.4.1, each shelf or other provision for loading is to be:

- a) Adjusted to the position that results in least stability; and
- b) Loaded with the maximum load specified in the marking required in 169.10; or
- c) Loaded with a 15 pound (6.81 kg) weight secured to prevent movement and centered on the highest shelf or rack.

132.5 Test results

132.5.1 The results of the test do not meet the intent of the requirement when the portable luminaire tips over.

133 Strain Relief Test

133.1 General

133.1.1 All strain reliefs provided on a portable luminaire shall be tested as described in 133.2. Compliance criteria is described in 133.3.

133.2 Test method

133.2.1 The conductors of the flexible cord are to be severed immediately adjacent to the terminals or splices except that the cord is not to be severed when any of the following occur:

- a) A knot is used as a strain relief;
- b) The construction is of the type described in Exception No. 1 of 17.1; or
- c) The construction is of the type described in Exception No. 2 of 17.1.

133.2.2 A 35 pound (16 kg) weight is to be suspended from the cord for 1 minute so that the force is applied in a direction normal to the plane of the surface containing the cord opening or bushing. When the lamp surface that supports the strain relief is fragile, care is to be taken to properly support that surface during the test. For instance, when the strain relief consists of a knot in the cord bearing against the side of a ceramic figurine, the surface under the figurine is to be padded such that the pull exerted on the cord is the only strain on the area providing the strain relief.

133.2.3 The strain-relief device required by Exception No. 5 of 9.5 shall comply with the requirements specified in this Section except that a weight of 20 pounds (9.1 kg) is to be used.

133.3 Test results

133.3.1 The results of the test do not meet the intent of the requirement when any of the following conditions occur:

- a) The insulation or covering on the flexible cord or wiring is cut or torn.
- b) The bushing slides through the hole in the chassis or enclosure.
- c) A cemented-on bushing slides on the cord.
- d) For a cord or wiring that is not severed at the terminals, strain is placed on internal conductors.
- e) For a cord or wiring that is severed at the terminals, there is movement of the cord of more than 1/16 inch (1.6 mm) at the points where the connections are made or where the conductors are permanently assembled to the terminals.

134 Drop Test

134.1 General

134.1.1 The Drop Test described in 134.2 is only conducted when the Exception to 132.1.1 is applied. Compliance criteria is described in 134.3.

134.2 Test method

134.2.1 One sample of a shelf mounted unit shall be dropped 3 feet (91.4 cm) onto a tissue paper covered nominal 1/2 inch (12.7 mm) thick trade size, knot-free softwood including plywood sheet supported by a concrete floor. The unit shall be energized for this test.

134.2.2 The unit shall remain energized for 1 hour.

134.3 Test results

134.3.1 There shall be no:

- a) Emission of flame or molten metal;
- b) Combustion of unit or test surface;
- c) Exposure of parts involving a risk of electric shock; or
- d) Dielectric breakdown when subjected to the Dielectric Voltage-Withstand Test, Section 137.

135 Security of Screws Test

135.1 General

135.1.1 The following tests described in 135.2 applies to self-threading or sheet-metal screw used to:

- a) Mount or support a part that weighs more than 7-1/2 pounds (3.4 kg);
- b) Join two or more sheets of material other than sheet steel.

Exception: These tests are not required to be conducted when the screw threads through the sheet material into sheet steel.

135.1.2 Compliance criteria is described in 135.3.

135.2 Test method

135.2.1 A self-threading or sheet metal screw used to join two or more sheets of material other than sheet steel, with a No. 6 or smaller screw shall be subjected to a tightening torque of 20 inch-pounds (2.2 N·m) and a No. 7 or larger screw shall be subjected to a tightening torque of 30 inch-pounds (3.4 N·m).

135.2.2 A self-threading or sheet-metal screw used to mount or support a part that weighs more than 7-1/2 pounds (3.4 kg) shall be subjected to a force equal to four times the weight of the part applied in a direction coincident with the longitudinal axis of the screw.

135.3 Test results

135.3.1 Test results meet the intent of the requirement when the threads of the screw do not strip or pull out of the sheet metal.

GENERAL – ELECTRICAL TESTS

136 Grounding Continuity Test

136.1 General

136.1.1 The following test described in 136.2 applies to accessible dead metal parts that are required to be grounded in accordance with Grounding and Bonding, Section 36. Compliance criteria is described in 136.3.

136.2 Test method

136.2.1 The impedance between the point of connection of the equipment-grounding means and any other accessible metal part required to be grounded, shall be determined by applying a current of 25 amperes – derived from a 60 hertz source with a no-load voltage not exceeding 6 volts – between the grounding connection and the metal part in question. The resulting impedance is calculated by dividing the value of the measured voltage by the applied current (25 A).

136.3 Test results

136.3.1 The results meet the intent of the requirement when the impedance between the point of connection of the equipment-grounding means and any other metal part that is required to be grounded does not exceed 0.1 ohm.

137 Dielectric Voltage-Withstand Test

137.1 General

137.1.1 The following test described in 137.2 applies to portable luminaires having accessible dead metal parts or low voltage circuits. Compliance criteria is described in 137.3.

137.2 Test method

137.2.1 A portable luminaire shall have a 1200 volt, 40 – 70 hertz potential applied for 1 minute between:

- a) Primary wiring, including connected components, and accessible dead metal parts of a portable luminaire that becomes energized, including those parts that are accessible only during relamping; and
- b) Primary wiring and accessible low-voltage – 42.4 volts peak or less – metal parts, including terminals.

137.2.2 The test equipment shall include a transformer having a sinusoidal output. When the output of the transformer is less than 500 volt-amperes, the equipment shall include a voltmeter in the output circuit to directly indicate the test potential. When the output of the transformer is 500 volt-amperes or larger, the test potential is indicated by a voltmeter in the primary circuit or a tertiary-winding circuit, by a selector switch marked to indicate the test potential, or by a marking in a readily visible location to indicate the test potential of equipment having a single test-potential output.

137.3 Test results

137.3.1 The results meet the intent of the requirement when there is no electrical breakdown.

138 Transformer Voltage Output Test

138.1 General

138.1.1 The following test described in 138.2 applies to a transformer that has been evaluated in accordance with end-use test requirements for Transformers, Section 44. Compliance criteria is described in 138.3.

138.2 Test method

138.2.1 The output of an isolated, low voltage transformer is to be measured with the portable luminaire or the transformer primary connected to rated voltage and all load circuits disconnected from the transformer under test. The measurement is to be made at the output terminals of the transformer. When a tapped transformer winding is used to supply a full-wave rectifier, the voltage measurements are to be made from each end of the winding to the tap.

138.3 Test results

138.3.1 The results meet the intent of the requirement when the output voltage does not exceed 30 volts.

139 Low Voltage Hinged or Movable Part Cycling Test

139.1 General

139.1.1 The following test described in 139.2 applies to low-voltage hinged or movable parts that are used to carry current in accordance with Secondary Low Voltage Circuits, Section 38. Compliance criteria is described in 139.3.

139.2 Test method

139.2.1 A hinge or joint between movable parts used to carry current in accordance with Exception No. 1 of 38.4 shall not have a temperature rise greater than 50°C (90°F) as a result of carrying the maximum normal current after 6000 operations of the hinge or movable part.

139.2.2 The hinge or movable part is to be flexed for 6000 operations through the full range permitted by the construction while the joint is carrying the maximum rated current. The temperature rise is to be measured at the conclusion of the test cycling, with the hinge or movable part shielded from external sources of heat such as transformer and lamp, and is to be measured with the joint in the position causing maximum heating due to increased resistance in the circuit.

139.3 Test results

139.3.1 The results meet the intent of the requirement when the hinge or joint between movable parts used to carry current does not have a temperature rise greater than 50°C (90°F).

140 Resistance to Moisture Test

140.1 General

140.1.1 The following test described in 140.2 applies to a portable luminaire using insulating material that is able to be adversely affected by moisture under its intended operating conditions such as a plant lamp. Compliance criteria is described in 140.3.

140.2 Test method

140.2.1 The portable luminaire shall be conditioned for 24 hours in moist air having a relative humidity of 88 ± 2 percent at a temperature of $32.0 \pm 2^\circ\text{C}$ ($89.6 \pm 3.6^\circ\text{F}$). After conditioning, the leakage current shall be measured as described in this Section.

140.2.2 Unless otherwise specified, the test is to be conducted with the portable luminaire connected to a source of supply of rated frequency and of maximum rated voltage except that the voltage is to be 120 volts for a lamp rated between 110 and 120 volts.

140.2.3 Leakage current refers to all currents, including capacitively coupled currents, that are able to be conveyed between exposed conductive surfaces of a lamp.

140.2.4 When a conductive surface other than metal is used for the enclosure or part of the enclosure, the leakage current is to be measured using metal foil having an area of 10 by 20 centimeters in contact with the surface. When the surface has an area less than 10 by 20 centimeters, the metal foil is to be the same size as the surface. The metal foil is not to remain in place long enough to affect the temperature of the lamp.

140.2.5 The measurement circuit for leakage current is to be as illustrated in Figure 140.1. The measurement instrument is defined in (a) – (c). The meter that is actually used for a measurement is required to only indicate the same numerical value for a particular measurement as the defined instrument. The meter used is not required to have all the attributes of the defined instrument.

- a) The meter is to have an input impedance of 1500 ohms resistive shunted by a capacitance of 0.15 microfarad.
- b) The meter is to indicate root mean square values which is 1.11 times the average of the full-wave rectified composite waveform of the current through the resistor.
- c) Over a frequency range of 0 – 100 kilohertz, the measurement circuitry is to have a frequency response – ratio of indicated to actual value of current – that is equal to the ratio of the impedance of a 1500 ohm resistor shunted by a 0.15-microfarad capacitor to 1500 ohms. At an indication of 0.5 milliamperes, the measurement is not to have an error of more than 5 percent at 60 hertz.

Figure 140.1
Leakage-current measurement circuit

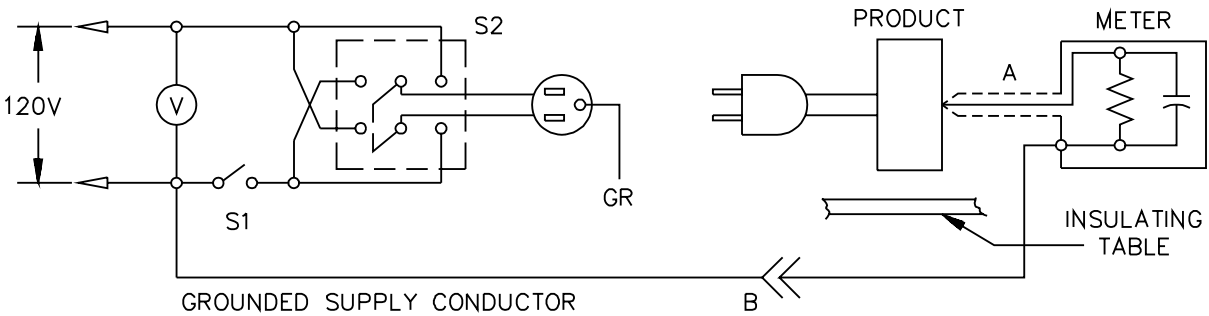

LC100

Portable luminaire intended for connection to a 120 volt power supply.

- a) Probe with shielded lead.
- b) Separated and used as clip when measuring currents from one part of device to another.

140.2.6 Unless the meter is being used to measure leakage from one part of a portable luminaire to another, the meter is to be connected between the accessible parts and the grounded supply conductor (neutral).

140.2.7 The portable luminaire is to be tested for leakage current with the grounding conductor open at the attachment plug. The supply voltage is to be adjusted to the voltage specified in 140.2.2. The test sequence, with reference to the measuring circuit, is to be as follows:

- a) With switch S1 open, the portable luminaire is to be connected to the measuring circuit. Leakage current is to be measured using both positions of switch S2 and with the unit switching devices in all their normal operating positions.
- b) Switch S1 is then to be closed energizing the portable luminaire, and within 5 seconds, the leakage current is to be measured using both positions of switch S2, and with the unit switching devices in all their normal operating positions.
- c) The leakage current is to be monitored until thermal stabilization. Both positions of switch S2 are to be used in determining this measurement. Thermal stabilization is to be obtained by operation as in the Normal Temperature Test, Sections 124 – 128.

140.3 Test results

140.3.1 The results meet the intent of the requirement when the leakage current does not exceed 0.5 milliamperere.

INCANDESCENT UNIT TESTS

141 Lamp Harp Torque Test

141.1 General

141.1.1 Lamp harps evaluated to Exception No. 3 of 47.4.2 shall be subjected to the following test described in 141.2. Compliance criteria is described in 141.3.

141.2 Test method

141.2.1 The harp shall be supported vertically as intended in service. When adjustable in height, the harp is to be adjusted for the maximum height.

141.2.2 A lever arm, nominal 1/8 inch (3.18 mm) thick by 1 inch (2.54 cm) wide by 24 inches (30.5 cm) long minimum, shall be centered and attached to the harp shade mounting stud and arranged such that when a force is applied, it is perpendicular to the centerline of the harp uprights. The lever arm shall extend enough in the other direction to counterbalance the weight of the lever arm so that the lever arm weight is cancelled from the moment force. See Figure 141.1.

Figure 141.1
Lamp harp torque test

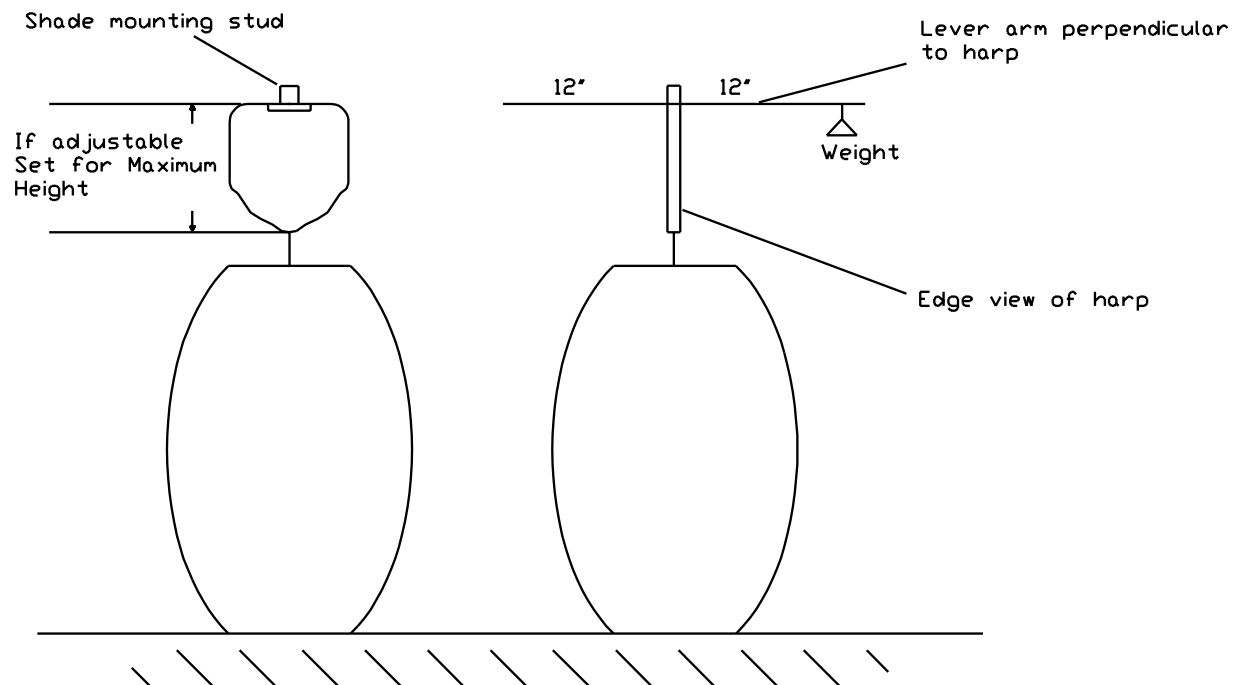

SM1077

141.2.3 A weight of 2 pounds (0.91 kg) shall be attached to the lever arm at a distance of 12 inches (30.5 cm) from the centerline of the harp mounting stud.

141.3 Test results

141.3.1 The harp is to withstand the applied force for 1 minute of 24 inch-pounds (2.70 N·m) without visible permanent deformation. The harp and/or lever arm is not prohibited from bending during the test. Return to the original position after the test.

142 Lampshade Ease of Ignition Test

142.1 General

142.1.1 A lampshade evaluated in accordance with Exception No.2 of 47.4.2 shall be subjected to the following test described in 142.2. Compliance criteria is described in 142.3.

142.2 Test method

142.2.1 Two complete lampshades shall be conditioned for seven days in an air circulating oven at a temperature of 70°C (158°F).

142.2.2 After conditioning, a Type PS25 300 W Lamp is energized for five minutes and then while still energized is placed in direct contact with the interior surface of the shade for a 3 hour time period. See Figure 142.1.

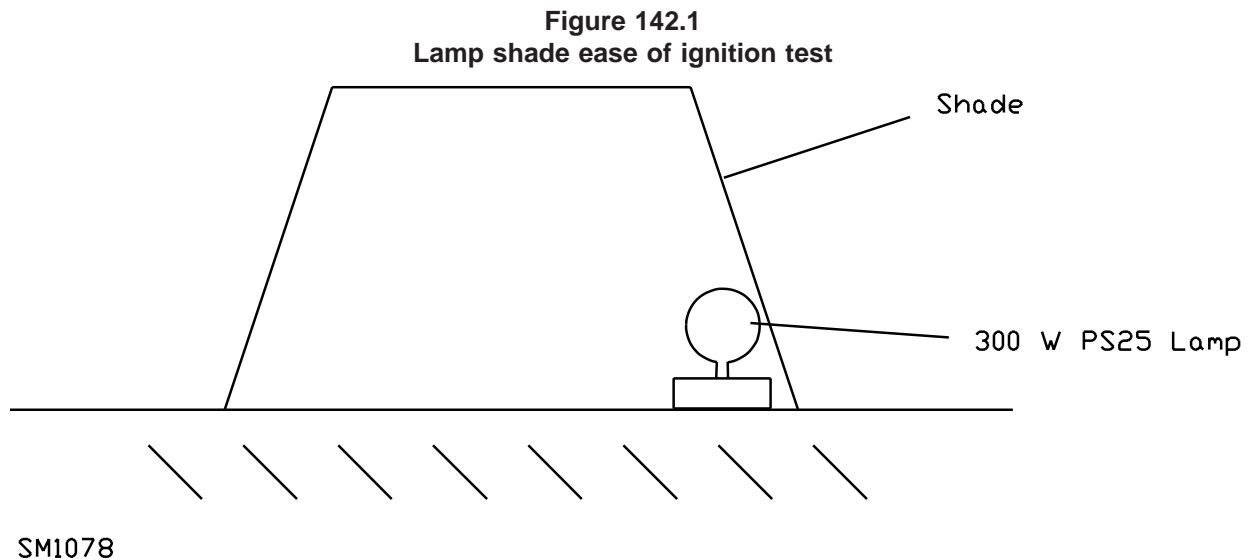

Interior of shade in contact with energized lamp.

142.3 Test results

142.3.1 No open flaming shall occur. Charring of the material shall be limited to the immediate area of light lamp contact.

TUNGSTEN-HALOGEN UNIT TESTS

143 Tungsten Halogen Lamp Adjacent Surfaces and Overlamping Abnormal Operation Tests

143.1 General

143.1.1 A tungsten-halogen type unit is to be subjected to the tests described in 143.1.2 for the general conditions and 143.3 – 143.7 for the specific conditions. Compliance criteria is described in 143.8. When a portable luminaire is damaged during any test, a new unit is to be used for subsequent tests.

Exception No. 1: A portable luminaire that complies with the mounting means requirements in Mounting Means Tests, Sections 156 or 157 is not required to be subjected to the Severe Condition Test, 143.3.

Exception No. 2: The Vertical Surface Test, 143.4, is not required when equivalent operation is obtained during the Normal Temperature Test, Sections 124 – 128.

Exception No. 3: The Supporting Surface Test, 143.5, is not required when equivalent operation is obtained during the Normal Temperature Test, Sections 124 – 128.

Exception No. 4: The Overhead Surface Test, 143.6, is not required when equivalent operation is obtained during the Normal Temperature Test, Sections 124 – 128.

Exception No. 5: The Overlamping Test, 143.7, is not required when equivalent operation is obtained during the Normal Temperature Test, Sections 124 – 128.

143.1.2 A tungsten-halogen unit that:

- a) Uses an Edison base, double envelope tungsten-halogen lamp similar in shape to a Type A incandescent lamp;
- b) Is rated 100 watts or less;
- c) Complies with the shade dimension requirements of Section 47 for Temperature Test-Exempt Units employing a 100 watt lamp and a medium base; and
- d) Is marked in accordance with 169.3.1;

is not required to be subjected to any abnormal operations tests.

143.2 Test method – general

143.2.1 To determine that the ultimate results have been observed, up to 7 hours of continuous operation is required.

143.2.2 To determine that the most severe condition has been evaluated, a portable luminaire is to be tested in several positions. The positions used are not required to be normal positions of use.

143.2.3 An automatic temperature-regulating or limiting control or other protective device provided as a part of the portable luminaire is to be shunted out of the circuit during these tests, unless the control has been shown by an investigation to be reliable and undefeatable by the user.

143.2.4 A part of the unit that is removable without the use of a tool is to be removed prior to these tests when its removal results in a more severe condition.

143.2.5 The tissue paper used in the abnormal test is to be untreated white paper commonly used for gift wrapping.

143.3 Test method – severe condition

143.3.1 A portable luminaire is to be placed in a position representing the most severe condition, regardless of mounting means, on the test surface.

143.3.2 After having been positioned, the portable luminaire is to be operated without further guiding or propping.

143.3.3 For a chain suspended shop-light type portable luminaire using tungsten halogen lamps, the Severe Condition Test shall be conducted with the unit suspended as intended with the tissue covered paper placed up against the bottom of the lamp compartment. The test indicator shall be parallel to the floor to simulate stacked boxes.

143.4 Test method – vertical surface

143.4.1 A portable luminaire is to be operated after being placed or mounted as intended as close as permitted by the lamp construction to a vertical test surface located at a right angle to the support or mounting surface. When a lamp is adjustable, it is to be:

- a) Positioned as close to; and
- b) Directed toward,

the vertical test surface to the greatest degree permitted by the construction of the portable luminaire.

143.5 Test method – supporting surface

143.5.1 A portable luminaire is to be operated after being placed or mounted as intended on the test surface and operated continuously. Among the abnormal conditions to be evaluated is operation of the lamp:

- a) Positioned as close to; and
- b) Directed toward,

the supporting surface to the greatest degree permitted by the construction of the unit.

143.6 Test method – overhead surface

143.6.1 A portable luminaire is to be operated after being placed or mounted as intended under a test surface. The height of the surface above the portable luminaire is to be determined by intended use of the unit and is to be as specified in the markings, 171.3.5. Among the conditions of operation to be evaluated is operation of the unit:

- a) Positioned as close to; and
- b) Directed toward,

the overhead surface to the greatest degree permitted by the construction of the portable luminaire.

143.7 Test method – overlamping

143.7.1 A portable luminaire is to be operated in a position of normal use with a lamp rated 500 watts or the maximum wattage lamp that physically fits into the unit. However, when the lamp is energized through a transformer, the test is to be conducted with the highest wattage lamp that does not result in transformer burnout in 7 hours, or does not result in a protective device functioning. The lamp type shall be of the same type specified in the lamp replacement marking. For example, a portable luminaire intended for use with a medium base Type PAR38 lamp shall be tested with a Type PAR 38 lamp. Other commonly available similar lamp types (i.e. a smaller par lamp) shall also be used for this test.

143.8 Test results

143.8.1 There shall be no:

- a) Emission of flame or molten metal;
- b) Combustion, glowing or flaming or disintegration of the material on which the unit is resting or of material placed on or near the unit;
- c) Exposure of parts involving a risk of electric shock; or
- d) Dielectric breakdown when subjected to the Dielectric Voltage-Withstand Test, Section 137, during any of these tests.

144 Tungsten-Halogen Lamp Guard, Lamp Containment Barrier, and UV Filter Security Test

144.1 General

144.1.1 A tungsten-halogen type unit is to be subjected to the test described in 144.2. Compliance criteria is described in 144.3.

Exception: A unit that complies with the Mounting Means Tests, Section 156, Mounting Means Test – Surface Mounted Unit, or Section 157, Mounting Means Test – Chain and Suspended Units, is not required to comply with this test.

144.2 Test method

144.2.1 All portable luminaires except floor type units are to be operated until temperatures are stable and then dropped, while plugged in and operating, through a distance of 3 feet (0.9 m) so that the unit strikes the test surface in a position most capable of damaging or altering a guard, lamp containment barrier, or a UV filter of the unit. Operation shall continue for 7 hours or until ultimate results are obtained.

144.2.2 A floor type unit is to be operated until temperatures are stable and then tipped over, while plugged in and operating, so that the unit strikes the test surface in a position most capable of damaging or altering a guard, lamp containment barrier, or a UV filter of the unit. The sample is to be placed on a flat horizontal surface and is to be tipped over by gradually and slowly pushing the top of the portable luminaire beyond the point of instability until it free-falls. Operation shall continue for 7 hours or until ultimate results are obtained.

144.2.3 The test surface is to be nominal 1/2-inch thick trade size, knot-free, softwood or plywood. The test surface is to be covered with a double layer of white tissue paper and completely supported by a concrete floor.

144.2.4 The tissue paper used in the test is to be untreated white paper commonly used for gift wrapping.

144.2.5 A part of a portable luminaire that is removable without the use of a tool is to be removed prior to this test when its removal results in a more severe condition.

144.3 Test results

144.3.1 There shall be no:

- a) Emission of flame or molten material;
- b) Combustion of the material under or near the fallen unit;
- c) Detachment of the guard, lamp containment barrier, or UV filter from the unit, or damage to the extent that spacings are reduced or openings occur which increase the risk of fire or personal injury; and
- d) Dielectric breakdown when subjected to the Dielectric Voltage Withstand Test described in Section 137 following the test.

145 Tungsten-Halogen Torchiere Abnormal Operation Test

145.1 General

145.1.1 One sample of a tungsten-halogen torchiere style floor unit as described in 54.3 shall be subjected to the test described in 145.2. Compliance criteria is described in 145.3.

145.2 Test method

145.2.1 The tungsten-halogen test lamp is to be a Philips brand lamp rated for the maximum wattage marked on the unit at 120 volts. When the portable luminaire is marked for a lamp wattage not produced by Philips, a test lamp by another manufacturer is to be used.

145.2.2 When a dimmer or other lamp-wattage reducing device is provided as a part of the portable luminaire, the device is to be shunted from the circuit for this test. A protective device such as an automatic temperature-regulating or -limiting control is also to be shunted from the circuit, unless the control is evaluated and found reliable.

145.2.3 Any part of a portable luminaire that is removable without the use of a tool is to be removed prior to the test when removal results in a more severe test condition.

145.2.4 The risk of fire indicator is to be double-layered, bleached cheesecloth, running 14 – 15 square yards per pound (26 – 28 m²/kg) per layer, and having a count of 32 by 28, that is, for any square inch there are 32 threads in one direction and 28 in the other direction (for any square centimeter, there are 13 threads in one direction and 11 threads in the other direction). The cheesecloth is to be wrapped around a 6 inch (15.2 cm) wide, 1/16 inch (1.6 mm) thick mandrel with length equal to the width of the cheesecloth. The mandrel is then removed to form a 10 double layer pad. The overall length of the pad is to be long enough to drape over the edge of the shade at both ends and is not to exceed twice the maximum diameter or diagonal of the shade.

145.2.5 The unit is to be placed in a draft-free room and connected to a variable 120-volt source of supply, adjusted to produce rated lamp wattage. The unit is to be energized for 15 minutes. Without being compressed, the cheesecloth pad is to be placed on top of the unit so that it is centered along the axis of the test lamp. The cheesecloth pad is to follow the contour of the guard, so that it extends over the edge of the shade at both ends, and is as close to the lamp as the torchiere's construction permits.

145.2.6 A unit tested with the guard removed is to have the cheesecloth pad in contact with the lamp containment barrier or the lamp envelope. The probes described in 52.3.7 are to be used to position the pad as close to the lamp envelope as permitted by the torchiere's construction features.

145.2.7 The unit is to be operated until:

- a) The cheesecloth ignites (flames);
- b) A hole develops in any layer of cheesecloth; or
- c) 7 hours has elapsed.

145.2.8 Identification of holes in the cheesecloth is to be made at the conclusion of the test by visual examination, without disturbing the cheesecloth in a manner that displaces any discolored material.

145.2.9 A unit with an automatic temperature regulating or limiting control, that is relied on for supplementary protection, shall be subjected to the test described in this Section with the following additional conditions:

- a) The test is to be conducted at rated lamp wattage with the cheesecloth pad centered along the axis of the test lamp, as specified in 145.2.5.
- b) The test in (a) is then to be repeated with the test pad positioned at 90 degrees with respect to the axis of the test lamp and in any other position that results in a longer time for the control to operate.
- c) The test is to be repeated with the cheesecloth in the position of (a) or (b) that resulted in the longest time for the control to operate, with the unit's wattage reduced in 50-watt increments for dimmers that are continuous by changing the input voltage, or selecting a lower step wattage setting for dimmers that are not continuous, until the unit operates for 7 hours without operation of the control device.

The unit complies with the testing requirements when the conditions of 145.3 are met.

145.3 Test results

145.3.1 There shall be no:

- a) Ignition (flaming) of the cheesecloth; or
- b) Holes in any layer of the cheesecloth.

146 Tungsten-Halogen Torchere Vertical Wall Test

146.1 General

146.1.1 Following the test specified in Section 143, Tungsten-Halogen Torchere Abnormal Operation Test, the sample shall be subjected to the test in 146.2. Compliance criteria is described in 146.3.

146.2 Test Method

146.2.1 The unit is to be laid on its side in the tipped-over position. With an operable lamp inserted, the unit is to be operated a rated wattage, and placed next to the wall described in 146.2.3.

146.2.2 For a unit with a flexible or articulated arm, the tipped-over position specified in 146.2.1 shall be the position that results in maximum heating of the plywood wall without actuating the tipover switch.

146.2.3 The wall is to consist of 3/4 inch (19.1 mm) thick fir plywood, and is to be covered with one layer of white, basically cotton terry cloth untreated fabric with a polyester content not more than 20 percent, and having a pile wave and a nominal weight of 8 ounces per square yard (270 g/m²). The wall is to extend at least 12 inches (305 mm) beyond the unit on both sides and 12 inches above the unit.

146.2.4 The unit is to be positioned at a distance from the wall that results in the highest temperatures on the plywood wall during operation.

146.2.5 The unit is to be operated until:

- a) There is glowing or flaming of the test indicator as indicated as described in 146.3; or
- b) 7 hours has elapsed.

146.2.6 The test is to be discontinued after 2 hours when this duration of testing produces no discoloration of the terry cloth material.

146.3 Test Results

146.3.1 There is to be no glowing or flaming of the terry cloth material or the plywood, including charring with cross-checking of the plywood as indicated by separation of the wood fibers in the direction of the grain.

147 Tungsten-Halogen Torchere Stability Test

147.1 General

147.1.1 A floor mounted tungsten-halogen torchere style portable luminaire not provided with a tipover switch shall be tested as described in 147.2. Compliance criteria is described in 147.3.

147.2 Test Method

147.2.1 The unit is to be placed on a plane inclined at an angle of 12 degrees with the horizontal and turned to any position of use presenting the greatest risk of tip over.

147.3 Test Results

147.3.1 The results of the test do not meet the intent of the requirement when the unit tips over.

148 Tungsten-Halogen Torchiere Flexible or Articulated Arm Stop Test

148.1 General

148.1.1 A tungsten-halogen torchiere style floor unit with a flexible or articulated arm that employs an end-stop to limit arm adjustment in accordance with 52.6 shall be tested as described in 148.2. Compliance criteria is described in 148.3.

148.2 Test Method

148.2.1 A tungsten-halogen torchiere unit is to be oriented as intended in normal use and have the flexible or articulated arm positioned against the end-stop. A 10 pound (22 kg) weight is to be applied to the end of the arm furthest away from the end-stop for 1 minute.

148.2.2 When the applied weight causes tipover of the unit, the torchiere base or other nonadjustable sections are to be secured to prevent tipover during this test.

148.3 Test Results

148.3.1 The end-stop shall not be damaged to the extent that the arm is able to move beyond the normal range.

149 *Reserved for future use*

150 Polymeric Lamp Containment Barrier Test

150.1 General

150.1.1 The test described in 150.2 apply only to that part of a lamp containment barrier (as defined by 2.22) that is of a polymeric material and is located where particles from a ruptured tungsten-halogen lamp drop to and rest. Compliance criteria is described in 150.3.

150.2 Test method

150.2.1 Three barriers are to be supported by their outer edges and oriented as intended during normal operation. A surface located 12 inches (305 mm) below the test samples is to be covered by a layer of dry absorbent cotton that is nominal 1/4 inch (6.4 mm) thick.

150.2.2 During the test, each sample of the lamp containment barrier material is to be heated to and maintained at the maximum operating temperature recorded when tested in accordance with the Normal Temperature Test, Sections 124 – 128.

150.2.3 Three cylindrical arc tube segments as specified in Table 150.1 are to be preheated to 1100°C (2012°F) for a minimum of 15 minutes.

Table 150.1
Quartz arc tube test segments

Lamp wattage	Outside diameter		Wall thickness		Length	
	inch	(mm)	inch	(mm)	inch	(mm)
150 or less	0.55	(14.0)	0.040	(1.0)	1/4	(6.4)
151 to 400	0.85	(21.6)	0.049	(1.24)	1/4	(6.4)
greater than 400	1.0	(25.4)	0.07	(1.9)	1/2	(12.7)

150.2.4 Each arc tube segment is then to be placed on the lamp containment barrier such that the longitudinal axis of the cylinder is perpendicular to the plane of the barrier. The transfer of each arc tube segment from the oven to the surface of the lamp containment barrier shall not exceed 2 seconds.

150.3 Test results

150.3.1 The results meet the intent of the requirement when during the testing of the samples, the dry absorbent cotton located below the test samples is not ignited by:

- a) Flaming drops of plastic material; or
- b) Any arc tube segment that penetrates the lamp containment barrier material and falls on the cotton.

151 Interlock Switch Endurance Test

151.1 General

151.1.1 The following test described in 151.2 applies to a tungsten-halogen interlock switch that has been evaluated in accordance with 53.2. Compliance criteria is described in 151.3.

151.2 Test method

151.2.1 A tungsten-halogen type unit provided with an interlock switch shall be connected to a supply circuit of 60 Hz and operated at rated lamp wattage. The switch shall be operated by means of the interlocking mechanism provided in the unit for 500 cycles at a rate of not exceeding 6 cycles per minute. Dead-metal parts of the switch shall be connected to earth ground through a 3A quick-acting plug-type fuse. The switch contacts shall be located in the ungrounded conductor of the supply circuit.

151.3 Test results

151.3.1 When tested in accordance with 151.2, there shall be no electrical or mechanical malfunction of the switch, and the fuse connected to the dead metal does not open.

152 Heat Flux Density Measurement Test

152.1 General

152.1.1 One sample of the tungsten-halogen torchiere unit as described in 52.1.6 shall be subjected to the test described in this section.

152.2 Test method

152.2.1 The tungsten-halogen test lamp shall be identical to the test lamp used for the Tungsten-Halogen Torchiere Abnormal Operation Test, Section 145.

152.2.2 Test lamps (bulbs) shall not have an accumulated operating time history that results in greater than a 5 percent loss in output radiant energy at the time readings are taken. A comparison of heat flux density readings taken at any one conveniently reproducible reference location, such as 6 inches (152 mm) in front of the test lamp on the light beam axis, when the lamp is brand new, and after use in testing, shall be used to establish whether darkening exceeds the specified 5 percent limit.

152.2.3 When a dimmer or other lamp-wattage reducing device is provided as part of the unit, the device is to be shunted from the circuit for this test.

152.2.4 Any part of the unit that is removable without the use of tools is to be removed prior to the test when removal results in a more severe test condition.

152.2.5 The unit is to be placed in a draft-free room and connected to a variable 120-volt source of supply adjusted to produce rated lamp wattage.

152.2.6 When a guard is used to maintain the distance between the lamp and the combustible materials, the shortest distance between the heat source and either probe specified in 52.3.7 is to be measured and recorded. The receiving area of the measuring instrument is to be maintained at the distance from the heat source while measuring the heat flux density. In no case is the receiving area of the measuring instrument to be spaced less than 1/4 inch (6.35 mm) from the heat source.

152.2.7 The measuring instrument used in 152.2.6 is to be one which:

- a) Produces an average reading of the total radiant plus convection heat flux density incident on a circular or square flat receiving area of not less than 0.16 in² (1 mm²) or more than 0.032 in² (2 mm²);
- b) Has an overall diameter not exceeding 1 inch (25.4 mm);
- c) Has a field of view at the receiving surface which encompasses all of the available radiant energy emitting areas of the source under test;
- d) Has provision for the determination or compensation of the temperature of the receiving surface at the time of the heat flux density measurement so that the radiant and convective heat flux densities are able to be computed as that transferred relative to a room temperature [25 ±5°C (77 ±10°F)] black receiving body;
- e) Has a calibrated response to all radiant energy within the wavelengths of 0.3 to 20 microns; and
- f) Is capable of measuring net total heat flux density of 1.0 W/cm² within the specified wave length with an error not exceeding 10 percent.

152.2.8 Heat flux density readings shall be taken after 15 minutes of operation or when the lamp and its reflector and/or housing have reached thermal equilibrium, whichever occurs sooner.

152.3 Test results

152.3.1 During conditions of intended operation, and with the light beam directed in a vertical plane, a unit shall not produce a net total heat flux density exceeding 1.0 W/cm² at any point beyond the external surface of the lamp or containment barrier.

FLUORESCENT UNIT TESTS

153 Abnormal Operation – Shorted Starter Test

153.1 General

153.1.1 A fluorescent type unit provided with other than a manual starter or a Class P ballast shall be subjected to the following test described in 153.2. Compliance criteria is described in 153.3.

153.2 Test method

153.2.1 The starter is to be shorted and the portable luminaire loosely covered with a single layer of cloth and operated continuously.

153.2.2 To determine that the ultimate results have been observed, up to 7 hours of continuous operation is required.

153.2.3 The cloth used in the abnormal test is to be bleached cheesecloth, 36 inches (914 mm) wide, running 14 – 15 square yards per pound (26 – 28 m²/kg) and having what is known in the trade as a count of 32 by 28; that is, for any square inch 32 threads in one direction and 28 in the other direction (for any square centimeter, 13 threads in one direction and 11 in the other direction). The cloth is to be loosely draped over the unit being tested in order to serve as a flame indicator (presence of ash or burnt holes) and is not to be used as a blanket to trap heat.

153.3 Test results

153.3.1 There shall be no:

- a) Emission of flame or molten metal;
- b) Combustion, glowing or flaming or disintegration of the material on which the lamp is resting or of material placed on or near the unit;
- c) Exposure of parts involving a risk of electric shock; or
- d) Dielectric breakdown when subjected to the Dielectric Voltage-Withstand Test, Section 137.

HIGH-INTENSITY-DISCHARGE UNIT TESTS

154 Glass Impact Test

154.1 General

154.1.1 The following test described in 154.2 is applicable to metal halide lamps without integral outer glass envelopes. Compliance criteria is described in 154.3.

154.2 Test method

154.2.1 A sample of the glass lamp containment barrier installed in a portable luminaire shall withstand 5 foot-pound (6.8 N-m) impact from a 2 inch (50.8 mm) diameter steel ball weighing 1.18 pounds (0.54 kg) applied to the center of the glass lamp containment barrier.

154.2.2 The glass lamp containment barrier is to be subjected to the impact by releasing the steel ball from the height required to produce the desired impact force. The figure containing the glass containment barrier to be tested is to be supported by a rigid surface [3/4 inch (19.1 mm) thick tongue and groove oak flooring or 3/4 inch thick plywood over a concrete pad].

154.3 Test results

154.3.1 As a result of the test specified in 154.2, the glass shall not shatter or crack.

155 Glass Thermal Shock/Containment Test

155.1 General

155.1.1 The test described in 155.2 is applicable to units with metal halide lamps having a glass material other than tempered or borosilicate glass. Compliance criteria is described in 155.3.

155.2 Test method

155.2.1 Each of three samples of the lamp containment barrier material to be tested is to be supported by its outer edges and oriented as it would be during normal operation. The lamp containment barrier material is to be maintained at a temperature of $25 \pm 5^{\circ}\text{C}$ ($77 \pm 9^{\circ}\text{F}$).

155.2.2 Three arc tube segments, as specified in Table 150.1, are to be preheated to 1100°C (2012°F) for a minimum of 15 minutes.

155.2.3 Each arc tube segment is then to be removed from the oven and, within 2 seconds, placed on the thinnest part of each lamp containment barrier. Each arc tube segment is to be placed on the barrier such that the longitudinal axis of the cylinder is perpendicular to the plane of the barrier.

155.3 Test results

155.3.1 The results meet the intent for the requirement when none of the samples of the glass lamp containment barrier material shatter or crack.

SURFACE MOUNTED UNIT FOR WALL OR UNDERSHELF MOUNTING TESTS

156 Mounting Means Test – Surface Mounted Unit

156.1 General

156.1.1 A surface mounted unit that is required to be tested as specified in Table 68.1, Condition F shall be tested as described in 156.2. Compliance criteria is described in 156.3.

156.2 Test method

156.2.1 Each test is to be conducted using the hardware provided and with the unit mounted in accordance with the instructions provided. An adjustable luminaire is to be adjusted to the position that results in the most severe test.

Exception: When the instructions do not specify a minimum mounting surface, the tests are to be conducted using 3/8 inch (9.5 mm) trade size plaster board securely attached to studs on 16 inch (406 mm) centers.

156.2.2 A weight of three times the weight of the unit is to be gradually applied at the point of the maximum projection of the portable luminaire and maintained for 1 hour.

156.3 Test results

156.3.1 The test result does not meet the intent of the requirements when:

- a) The portable luminaire, separable mounting bracket or screws are pulled from the mounting surface;
- b) The portable luminaire becomes detached from the separable mounting bracket; or
- c) The portable luminaire is damaged to the extent that internal wiring, splices, a switch or uninsulated live parts are exposed. Wireways or decorative parts are able to be bent.

CORD AND CHAIN SUSPENDED UNIT TESTS

157 Mounting Means Test – Chain and Suspended Units

157.1 General

157.1.1 A portable luminaire constructed in accordance with the Exceptions to 72.2.1, 72.3.1, or 72.3.2 shall be tested as described in 157.2 and either 157.3 when a swag type or 157.4 when a hanging type. Compliance criteria is described in 157.5.

157.2 Test method – general

157.2.1 The weight of the unit is to be determined in accordance with 72.3.2. The portable luminaire is to be mounted in accordance with the manufacturer's instructions on a simulated ceiling.

157.2.2 The simulated ceiling described in 157.2.1 is to be of the following construction:

- a) For a plaster, dry wall, or similar ceiling, a 2 by 2 foot (610 by 610 mm), 3/8 inch trade size thick plaster board to be supported on opposite ends by trade size 2 by 4 inch studs.
- b) For a wood, acoustical tile, or similar ceiling, one 12 by 12 inch (305 by 305 mm), 3/8 inch trade size thick tile of the material(s) specified in the instructions to be supported on each end by trade size 1 by 2 inch furring strips.

157.3 Test method – swag unit

157.3.1 For a swag type unit, a load consisting of three times the weight of the unit is to be suspended from the mounting means of the unit (in addition to the unit) for a period of 1 hour.

157.4 Test method – hanging unit

157.4.1 For a hanging type unit, the maximum amount of weight that the cord is able to suspend is to be determined in accordance with Table 72.1. The difference between the weight of the portable luminaire and the maximum weight the cord is able to suspend is load "A". Load "A" is to be suspended from the unit for a period of 1 hour.

157.5 Test results

157.5.1 The results of the test do not meet the intent of the requirements when:

- a) The portable luminaire falls or is pulled away from the ceiling.
- b) There is damage to the unit exposing live parts or sharp edges which affect the performance of the unit; or
- c) Any other situation that results in a risk of fire, electric shock, or injury to persons.

158 Test for Suspended Toys

158.1 General

158.1.1 A portable luminaire with a suspended toy shall be subjected to the test described in 158.2. Compliance criteria is described in 158.3.

158.2 Test method

158.2.1 The unit is to be mounted in accordance with the manufacturer's instructions on a simulated ceiling. The simulated ceiling is to be of the same construction as that described in 157.2.2.

158.2.2 A weight is to be suspended from the toy. The weight is to be gradually increased until the toy becomes separated from the lamp.

158.2.3 The weight of the unit is to be determined in accordance with 72.3.2. When the weight of the lamp plus the weight of the load required to remove the toy exceeds:

- a) 30 pounds (13.6 kg) for the mounting means specified in 72.2.1; or
- b) The total amount of weight (unit plus load) tested in Test for Suspended Toys, Section 158;

the Mounting Means Test in Section 157 shall be conducted using a load of the weight required to remove the toy.

158.2.4 For a hanging unit, the weight of the luminaire plus the weight of the load required to remove the toy shall not exceed the limits of the cord as specified in Table 72.1.

158.3 Test results

158.3.1 The results of the test do not meet the intent of the requirements when any of the following conditions occur:

- a) The unit falls or is pulled away from the ceiling.
- b) There is damage to the unit resulting in exposed live parts or sharp edges which affect the performance of the unit; or
- c) Any other situation that results in a risk of fire, electric shock, or injury to persons.

CLAMP-ON UNIT TESTS

159 Mounting Means Test – Clamp-On Unit

159.1 General

159.1.1 A clamp-on unit relying on a spring-actuated clip for securement shall be subjected to the test described in 159.2. Compliance criteria is described in 159.3.

159.2 Test method

159.2.1 The test is to be conducted as follows:

- a) The unit is to be clamped to a smooth vertical unpainted metal surface 1/16 inch (1.6 mm) thick. A weight equal to the weight of the unit is to be attached at the point where the clamp is secured to the unit. See Figure 159.1.
- b) The test is to be repeated with the unit clamped to a smooth, unpainted pine wood surface 1-1/2 inches (38 mm) thick.
- c) For each of the above conditions, the weight is to be applied gradually and maintained for one hour.

Figure 159.1
Clamp-on unit setup

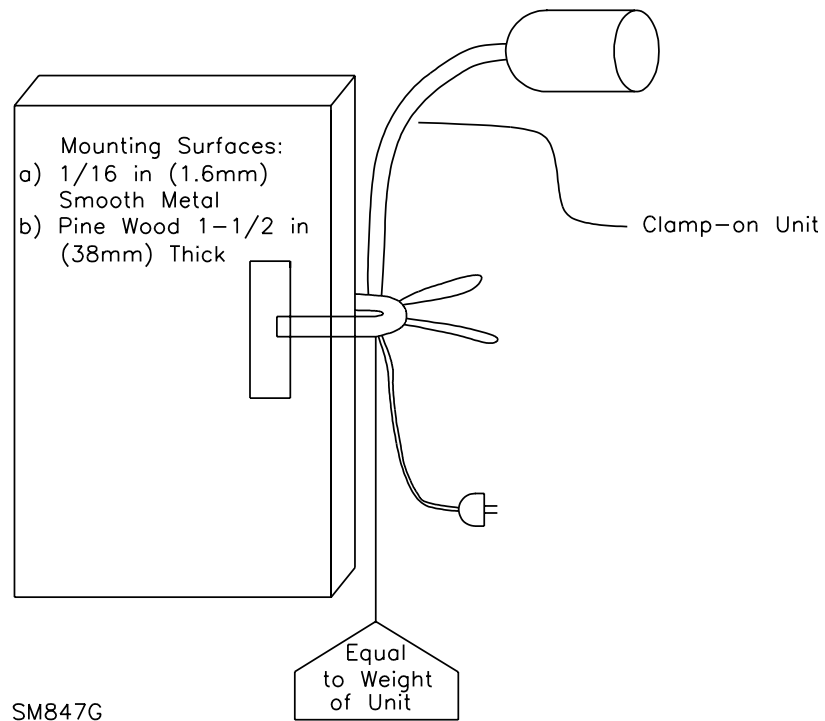

159.2.2 Any friction material not permanently secured to the spring clip is to be removed prior to conducting the tests in 159.2.1.

159.3 Test results

159.3.1 The portable luminaire shall not fall from the mounting surface as a result of the test. Pivoting of the unit is not prohibited.

TRACK-STYLE UNIT TESTS

160 Mechanical Means of Polarity Test

160.1 General

160.1.1 The following test described in 160.2 applies to interchangeable and track-style type units. Compliance criteria is described in 160.3.

160.2 Test method

160.2.1 An ohmmeter is to be connected between the two power-supply cord connectors that supply the unit.

160.2.2 An adapter that is wired to complete the circuit in 160.2.1 when inserted as intended, is to be inserted into the base (interchangeable unit) or bus-bar (track-style type unit) in an attempt to defeat the means of maintaining polarity. When a twist motion is normally used to insert the device, a torque of 15 pound-inches (1.7 N-m) is to be applied for 1 minute.

160.3 Test results

160.3.1 The test results meet the intent of the requirements when:

- a) The adapter and base or bus-bar show no damage affecting performance or construction;
- b) The ohmmeter shows no evidence that permanent electrical contact was made; and
- c) There is no reduction of spacings to values below the minimum spacing values specified in Electrical Spacing, Section 24.

161 Track Clip Securement Test

161.1 General

161.1.1 A mounting clip shall be tested as described in 161.2. Compliance criteria is described in 161.3.

161.2 Test method

161.2.1 A clip is to be mounted to a track as intended. The track is to be:

- a) Supported at both ends so that the track is in a horizontal position; and
- b) Oriented so that the track is upside-down with the clip at the midpoint of the track.

A 25 pound (11.4 kg) weight is to be suspended from the clip for 5 minutes.

161.2.2 The test described in 161.2.1 is to be repeated with the track:

- a) In a position that simulates wall mounting; and
- b) Oriented so the longitudinal openings on the track are horizontal.

161.3 Test results

161.3.1 Test results meet the intent of the requirement when:

- a) The clip remains in the intended mounting position without evidence of pulling away from the track; and
- b) The track is not distorted so that it results in:
 - 1) A reduction of spacings below the minimum required values specified in Electrical Spacings, Section 24; and
 - 2) Uninsulated live parts or internal wiring becoming accessible to contact.

PORTABLE LUMINAIRE SUBASSEMBLY TEST

162 Assembly and Installation Test

162.1 General

162.1.1 The following test described in 162.2 applies to a portable luminaire subassembly which requires assembly by the user. Compliance criteria is described in 162.3.

162.2 Test method

162.2.1 The portable luminaire subassembly is to be assembled or installed in accordance with the instructions provided by the manufacturer and evaluated in accordance with this standard. All required tests shall be conducted on the assembled product in accordance with this standard.

162.2.2 When more than one method of assembly is detailed in the instructions, each method shall be evaluated.

162.3 Test results

162.3.1 Test results meet the intent of the requirements when the assembled product complies with all requirements of the standard.

WORK LIGHT TESTS

163 Guard Securement Test

163.1 General

163.1.1 These requirements are applicable to work lights that rely on a securing means in accordance with 114.2.5.

163.2 Test method

163.2.1 A guard shall be subjected to the following forces, in any direction, in an attempt to remove the guard from the unit:

- a) A 5 pound (2.27 kg) push force; and
- b) For other than a tripod mounted unit, a pull off force equal to 4 times the weight of the unit, or 20 pounds (9.07 kg), whichever is less.

163.2.2 The results meet the intent of the requirement when the guard remains attached to the unit and complies with 114.2.3.

WET LOCATION USE TESTS

164 Rain and Sprinkler Tests

164.1 General

164.1.1 A portable luminaire that is intended to be used in wet locations shall be subjected to the rain test described in 164.2 and 164.3 and the sprinkler test described in 164.2 and 164.4. Compliance criteria is described in 164.5.

Exception: The rain test and sprinkler test are not required when the construction features of the unit are such that it is readily apparent that water does not enter the unit during its intended use.

164.2 Test method – general

164.2.1 A portable luminaire shall be positioned in the most severe position permitted by its base and any adjustment means.

164.2.2 A portable luminaire provided with a gasketed joint in the lamp compartment that is opened for relamping shall have the joint opened and reclosed prior to the rain and sprinkler tests. The unit shall be operated a minimum of 1/2-hour prior to opening the gasketed joint.

164.2.3 A portable luminaire with a connector or receptacle intended for interconnection of additional lighting units in accordance with 120.3 shall have a cord set plugged into the connector for the duration of the test.

164.2.4 The rain and sprinkler tests are to be conducted in the operating sequence illustrated in Table 164.1.

164.2.5 Immediately following the rain or sprinkler test, when there are accessible dead metal parts, the portable luminaire shall be subjected to the Dielectric Voltage Withstand Test, Section 137.

Table 164.1
Operating sequence

Duration in hours	Lamp	Water
1	On	Off
1/2	Off	On
2	On	On
1/2	Off	On

164.3 Test method – rain test

164.3.1 The rain test apparatus is to consist of three spray heads mounted in a water supply pipe rack as shown in Figure 164.1. Spray heads are to be constructed in accordance with the details shown in Figure 164.2. The portable luminaire is to be set up as in a normal installation when so intended. The enclosure is to be positioned in the focal area of the spray heads so that the greatest quantity of water enters the enclosure. The water pressure is to be maintained at 5 pounds per square inch (34.5 kPa) at each spray head.

Figure 164.1
Rain test apparatus
PLAN VIEW

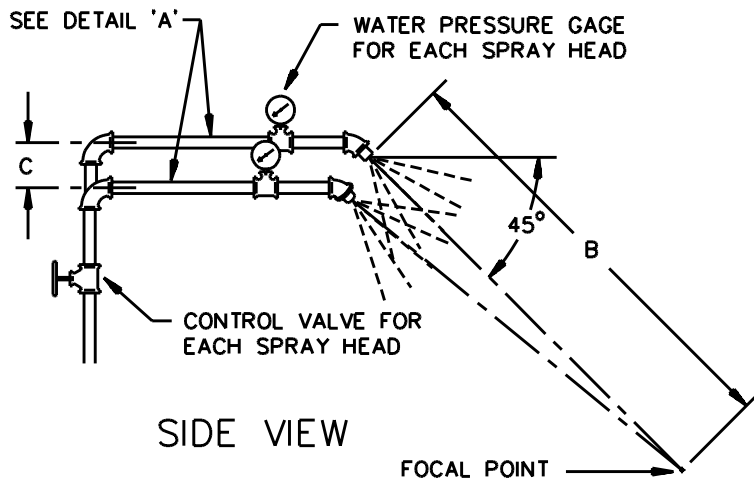
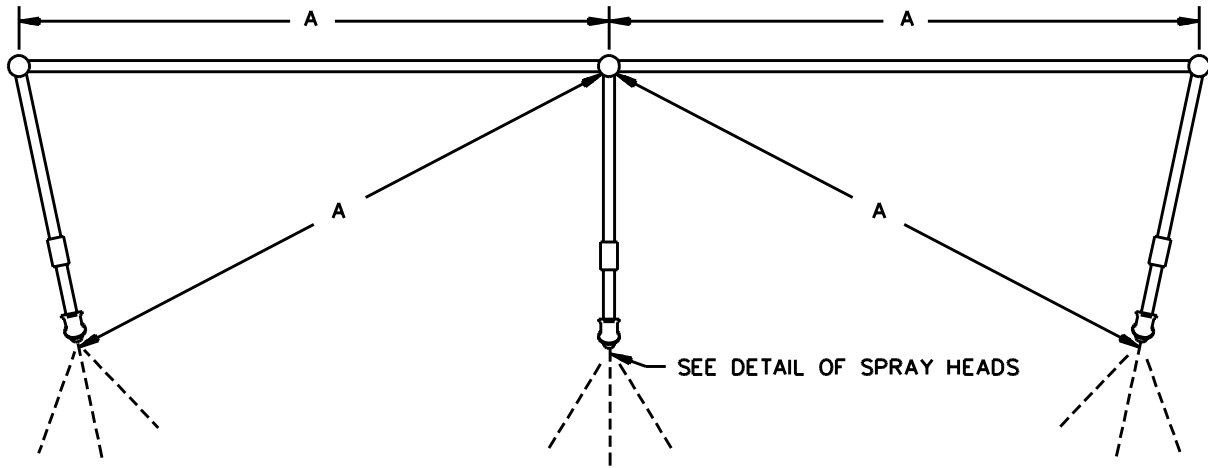

PIEZOMETER ASSEMBLY
DETAIL 'A'

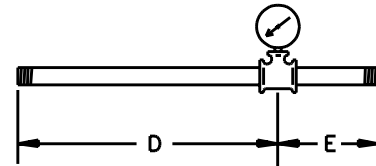

Item	inch	mm
A	28	710
B	55	1400
C	2-1/4	55
D	9	230
E	3	75

RT101D

Figure 164.2
Spray head
ASSEMBLY^a

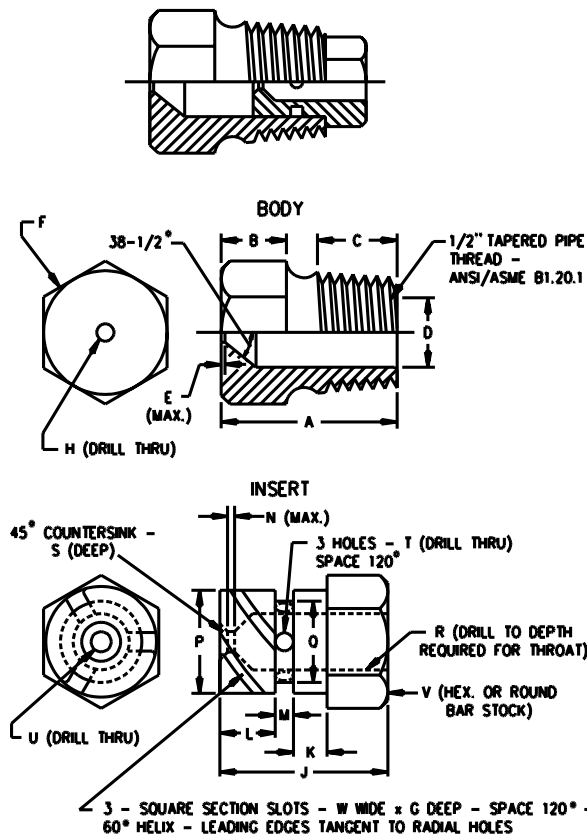

Item	inch	mm	Item	inch	mm
A	1-7/32	31.0	N	1/32	0.80
B	7/16	11.0	P	.575	14.61
C	9/16	14.0	Q	.453	11.51
D	.578	14.68	R	.454	11.53
E	1/64	0.40	S	1/32	0.80
F	c	c	T	(No. 35) ^b	2.80
G	.06	1.52	U	(No. 40) ^b	2.50
H	(No. 9) ^b	5.0	V	5/8	16.0
J	23/32	18.3	W	0.06	1.52
K	5/32	3.97			
L	1/4	6.35			
M	3/32	2.38			

^a Nylon Rain-Test Spray Heads are available from Underwriters Laboratories

^b ANSI B94.11M Drill Size

^c Optional - To serve as a wrench grip.

164.4 Test method – sprinkler test

164.4.1 A portable luminaire is to be turned about its vertical axis to each of four positions 90 degrees from each other, each for 30 minutes during the 2 hour portion of the test described in 164.4.2, with adjustable parts arranged for maximum vulnerability to the water spray.

164.4.2 The portable luminaire is to be positioned, as shown in Figure 164.3 in front of the standard water spray head of the type shown in Figure 164.2 to which the water pressure is maintained at a gauge pressure of 20 pounds per square inch (137.9 kPa).

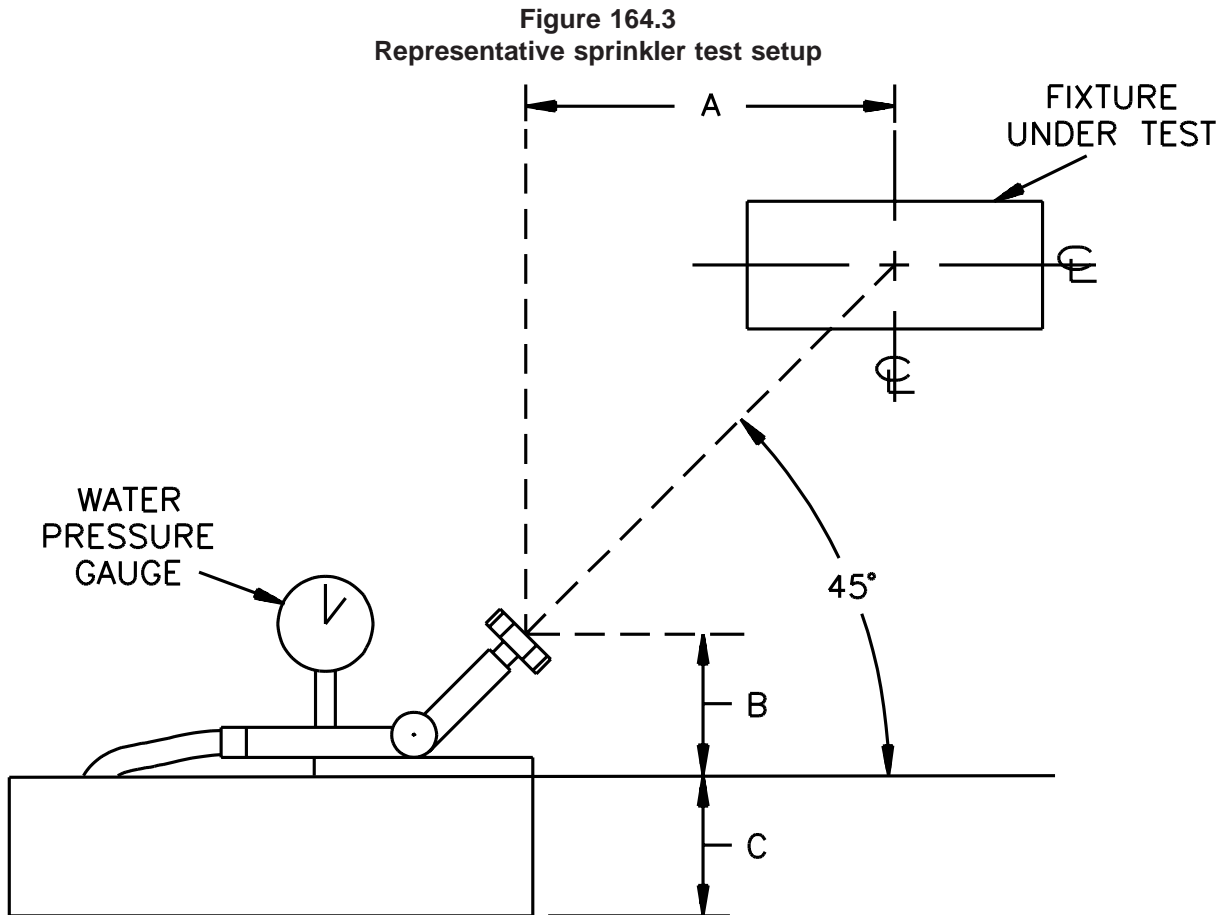

SB1840A

- a) 36 inches (914 mm).
- b) 3 – 6 inches (76.2 – 152 mm).
- c) Height required for the unit to be mounted as intended with the dimensional center of the unit on a line projected from the center line of the nozzle head.

164.5 Test results

164.5.1 Test results meet the intent of the requirements when after the rain, or sprinkler tests no water has entered the portable luminaire and the unit passes the dielectric voltage withstand test. The GFCI, when provided, shall not function.

Exception: Water shall not enter the unit unless:

- a) Water does not result in wetting of any lampholder, wiring or other electrical parts that are not inherently waterproof; and*
- b) The unit is provided with a drain hole as required by Drain Openings, 119.4.*

165 Polymeric Thermal Conditioning Test

165.1 General

165.1.1 A polymeric water shield that operates at a temperature between 65 – 95°C (149 – 203°F) and does not have a recognized temperature rating for the measured temperature shall be tested as described in 165.2. Compliance criteria is described in 165.3.

165.2 Test method

165.2.1 A polymeric water shield shall be conditioned in a circulating oven for 168 hours at a temperature in accordance with Table 165.1 and as determined by the Normal Temperature Test of Section 125, Test Method – General. The conditioning time is able to be reduced by one-half for each increase in oven temperature of 10°C (18°F). When the sample is too large for the test oven, the sample is to be cut to fit.

Table 165.1
Thermal conditioning exposure temperature

Normal test temperature in °C	Oven test temperature in °C
65 – 75	85
76 – 85	95
86 – 95	105

165.3 Test results

165.3.1 The water shield shall have no obvious deterioration or deformation after conditioning.

166 Gasket Accelerated Aging Test

166.1 General

166.1.1 A portable luminaire that is intended to be used in wet locations and employs a gasket or bushing material that is relied upon to comply with the requirements for wet locations shall be subject to the gasket accelerated aging test described in 166.2 for a separate gasket or bushing material, or 166.4 for a gasket or bushing evaluated in the end-product. Compliance criteria is described in 166.3 or 166.5 as applicable.

166.2 Test method A

166.2.1 Three samples each of the gasket or bushing material is to be tested for elongation and tensile strength in the as-received condition and after removal from the oven conditioning. The test methods and apparatus are described in Standard Test Methods for Rubber Properties in Tension, ASTM D412.

166.2.2 The oven conditioning specified in 166.2.1 shall be for 168 hours in a circulating air oven at a temperature 20°C (36°F) above the temperature measured on the gasket or bushing during the temperature test.

166.3 Test results A

166.3.1 The results meet the intent of the requirements when the gasket or bushing material have a tensile strength of not less than 60 percent and an elongation of not less than 75 percent of the values determined before conditioning.

166.4 Test method B

166.4.1 As an alternative to the test described in 166.2 and 166.3, a gasket or bushing employed to comply with the requirements for wet locations is to be tested in the end product as follows. With the gasket or bushing in place, the portable luminaire is to be conditioned in a circulating air oven for 240 hours at 20°C (36°F) above the temperature measured on the gasket during the Normal Temperature Test, Sections 124 – 128. After the conditioning, any panels that use the gasket or bushing for sealing are to be opened.

166.5 Test results B

166.5.1 The results meet the intent of the requirements when a visual inspection shows no damage to the gasket and the gasket has remained in place. The panels are then to be closed and the portable luminaire is to be subjected to the rain and sprinkler tests in 164.4 and 164.5.

167 Gasket Adhesion Test

167.1 General

167.1.1 A portable luminaire that is intended to be used in wet locations and employs a gasket secured by adhesive that is relied upon to comply with the requirements for wet locations shall be subject to a gasket adhesion test described in 167.2. Compliance criteria is described in 167.3.

167.2 Test method A

167.2.1 Three samples of the gasket attached to the intended mounting surface shall be tested in the as-received condition, three samples 1/2-hour after removal from the oven conditioning, and three samples 24 hours after removal from the oven conditioning.

167.2.2 The oven conditioning specified in 167.2.1 shall be for 168 hours in a circulating air oven at a temperature 20°C (36°F) above the temperature measured on the gasket adhesive during the temperature test.

167.2.3 The force required to remove the gasket from its mounting surface is to be measured by pulling the gasket strip from the test panel at an angle of 90 degrees and a cross head speed of 0.5 inches per minute (12.7 mm/min).

167.3 Test results A

167.3.1 The results meet the intent of the requirement when the gasket has an adhesion strength of not less than 60 percent of the value determined before conditioning.

167.4 Test method B

167.4.1 As an alternative to the test described in 166.2 and 166.3, a gasket secured by adhesive is to be tested in the end product as follows. With the gasket in place, the portable luminaire is to be conditioned in a circulating air oven for 240 hours at 20°C (36°F) above the temperature measured on the gasket during the Normal Temperature Test, Sections 124 – 128. After the conditioning, any panels that use the gasket for sealing are to be opened.

167.5 Test results B

167.5.1 The results meet the intent of the requirements when a visual inspection shows that there is no damage to the gasket and the gasket has remained in place.

168 Paint Adhesion Test

168.1 General

168.1.1 A painted enclosure or representative ferrous metal part that is protected against corrosion by an air-dry paint shall be subjected to the test in 168.2. Compliance criteria is described in 168.3.

168.2 Test method

168.2.1 An area of 1 inch² (625 mm²) shall be cross-cut with a sharp knife. The cuts in the same direction shall be parallel and spaced 0.40 inch to 0.80 inch (1.0 mm to 2.0 mm) apart. Cellulose adhesive tape shall be firmly applied to the cross-cut surface, and upon removal of the tape, not more than 15 percent of the paint shall be removed from the test sample.

168.3 Test results

168.3.1 When a sharp knife is scraped across the painted surface, the paint may have a tendency to curl, but shall not flake, crumble, or give evidence of lack of adhesion.

PART III

MARKINGS

169 General

169.1 Form

169.1.1 A required marking shall be legible and unless otherwise indicated, the types of marking and the minimum height of the letters shall be as specified by the applicable form letter in Table 169.1, and the location of the marking shall be as specified by the applicable form number in Table 169.2. The wording, form letter, and form number shall be as specified in the applicable paragraphs.

Exception: A marking of a form higher in Table 169.1 than required is able to be used. (Example: Form A1 is able to be used when Form B1 is specified.)

Table 169.1
Form designations for location of marking

Form letter of marking	Type
A ^a	Paint-stenciled, die-stamped indelibly stamped lettering, or indelibly printed label. The letters shall be at least 1/8 inch (3.2 mm) high.
B ^a	Pressure-sensitive label, decalcomania transfer, paper label, paint or ink or die-stamped lettering. A tie-on tag, stuffer sheet, or equivalent does not meet the intent of the requirement.
C	In the form of instructions on or with the portable luminaire. A tie-on tag, stuffer sheet, or equivalent meets the intent of the requirements.
^a This marking shall be on a portion of the portable luminaire that: <ol style="list-style-type: none"> 1) Is not removed during replacement of the lamp, and 2) Serves other than a purely decorative function. (For example, a marking on a removable lampholder sleeve shall be repeated on the lampholder itself and a marking on a fabric shade does not meet the intent of the requirement). 	

Table 169.2
Form designations for location of marking

Form no. of marking	Location of marking
1	On an exterior surface that is normally visible. Marking is determined to be normally visible when a lamp or glassware is required to be removed to make the marking visible.
2	Adjacent to the ballast and readily visible before and during ballast replacement.
3	At a point where visible during relamping.
4	On the smallest unit packaging carton.
5	At a point visible during mounting.

169.1.2 When the wording of a particular marking is given within quotation marks in this standard, the verbatim wording shall be used. Words located within parentheses are optional. Other substitute words are acceptable when the marking text is followed by the phrase "or the equivalent."

169.2 Form "A" marking label

169.2.1 The combination of a label material and ink used for Form A in Table 169.1 shall be permanent and rated for the type of surface and temperature of surface determined during the Normal Temperature Test, Section 124 – 128. The marking and labeling system shall comply with the Standard for Marking and Labeling Systems, UL 969.

169.2.2 The marking material temperature rating for portable luminaires complying with the Temperature Test-Exempt Units requirements in Sections 47 and 60 shall be at least 60°C (140°F), except:

Incandescent Temperature Test Exempt

- a) A material located on an incandescent lampholder shall be rated for a temperature of at least the lampholder lead wires as specified in Table 47.5;

Fluorescent Temperature Test Exempt

b) A material located on a fluorescent lampholder shall be rated for a temperature of at least the lampholder lead wires as specified in Table 58.1; and

c) A material located within 3 inches (76.2 mm) of a ballast shall be rated for a temperature of at least 80°C (176°F).

169.2.3 When the 1/8 inch (3.2 mm) minimum letter height required by a Form A-3 marking is not accommodated because of the product's small physical size, the letter height is not prohibited from being reduced when:

a) The specific marking permits a reduced marking size;

b) The signal word "WARNING" or "CAUTION" is a minimum of 7/64 inch (2.75 mm) high;

c) The text is a minimum of 1/16 inch (1.6 mm) high and contrasting in color to the background; and

d) When molded or stamped, the text is a minimum of 5/64 inch (2.0 mm) high and when not contrasting in color to the background, is raised or depressed a minimum of 0.01 inch (0.25 mm).

169.3 Tag type markings

169.3.1 For markings required to be on a tag, the tag shall be affixed to the cord. The marking shall be indelible.

169.3.2 Tag markings shall be provided in either of the following forms:

a) A hang-type tag having a hole to permit securement to the cord by a plastic strap or equivalent. The strap shall not be removable without cutting.

b) A flag-type tag with the adhesive back. The tag is to be wrapped around and adhere to the cord. The ends of the tag are to adhere to each other and project as a flag.

169.4 Pictograph type markings

169.4.1 A marking required elsewhere in this standard is able to be in the form of a pictograph or a combination of a pictograph and word(s) when the marking is investigated and found to contain:

a) An attention getting flag, symbol or word;

b) An indication of the possible risk; and

c) What is able to be done to reduce the risk.

169.5 Manufacturer's identification

169.5.1 A portable luminaire shall be marked in Form B-1 with the manufacturer's name, trademark, or other descriptive marking by which the organization responsible for the product, hereinafter referred to as the manufacturer, is identified.

169.5.2 When a manufacturer produces or assembles portable luminaires at more than one factory, each unit shall have a distinctive marking in Form B-1 by which it is able to be identified as the product of a particular factory. The absence of a marking is able to be used to identify one factory when the other factories have identifying marks.

169.6 Electrical ratings

169.6.1 A portable luminaire intended for use on other than a nominal 120 Volts supply shall be marked in Form B-1 with its input voltage rating.

169.6.2 A portable luminaire incorporating a component that is intended for use on alternating current only (such as a ballast, a transformer, or a switch rated "AC ONLY") shall be marked in Form B-1 with its voltage, current, and frequency rating.

169.6.3 A convenience receptacle shall be marked in Form A-1 on or near the receptacle with its rated voltage and current.

Exception: The receptacle shall be marked with its rated amperage when it is less than 15 amperes.

169.7 Mounting orientation

169.7.1 When a portable luminaire is able to be mounted in more than one orientation, such as either a wall or under a cabinet, and the correct orientation of the unit is required to comply with a specific requirement in this standard, it shall be marked in Form A-1, to indicate the correct orientation.

169.8 Hot surface marking

169.8.1 When the temperature measured on the exterior surface of a wall or ceiling unit during the Normal Temperature Test, Sections 124 – 128, exceeds 90°C (194°F) and does not exceed 150°C (302°F), the portable luminaire shall be marked in Form A-3 "CAUTION: Hot surface. Keep away from curtains and other combustible materials", or equivalent.

169.9 Interconnected units

169.9.1 An interconnected unit with a short cord in accordance with Interconnected Units, 33.9, shall be marked in Form B-5 "Only connect to adjacent units (or other appropriate product name)."

169.9.2 An interconnected unit shall be marked in Form A-1 adjacent to the receptacle " "a" units maximum", where "a" is the number of units.

169.9.3 An interconnected unit with an internal fuse shall be marked in Form A-1 adjacent to the fuseholder: " "b" A fuse maximum." where "b" is fuse ampere rating.

169.9.4 An interconnected unit without overcurrent protection in accordance with 89.3.2 shall be marked in Form B-3: "CAUTION – Risk of Electrical Shock or Fire, Use only on 15 Amp maximum branch circuit."

169.9.5 An interconnected unit that is intended to be connected to the secondary circuit of a ballast or transformer in an adjacent unit, or to a fused unit, shall be marked in Form B-5 "Only for use with (number of units) (catalog or parts number) manufactured by (manufacturer's name) (product name) or the equivalent."

169.10 Units with integral shelf, rack, or table

169.10.1 Each shelf, magazine rack, or other means that are part of the portable luminaires assembly and intended to support any object(s) shall be marked in Form A-1: "WARNING – Risk of tip over"; and "Max. _____ lb. Load", or equivalent, where the blank space specifies the maximum load in pounds.

Exception: When subjected to a Stability Test in accordance with 132.4.2 (a) and (c), the above marking in not required.

169.11 Resemblance to toy

169.11.1 A portable luminaire required by 18.4 to have a marking shall be marked: "WARNING – THIS IS AN ELECTRIC LAMP – NOT A TOY! TO AVOID RISK OF FIRE, BURNS, PERSONAL INJURY AND ELECTRIC SHOCK IT SHOULD NOT BE PLAYED WITH OR PLACED WHERE SMALL CHILDREN CAN REACH IT.", or equivalent.

169.11.2 The marking required by 169.11.1 shall be provided in contrasting colors and shall be:

- a) Form A where visible during initial setup and handling; and
- b) In letters a minimum of 1/4 inch (6.4 mm) high on the external surface of the carton or packaging where visible during purchase.

Exception: The carton marking shall not be omitted unless the product marking is 1/4 inch high and is visible through the packaging.

169.12 Marking for luminaires containing hazardous substances

169.12.1 With reference to 20.4, a portable luminaire containing hazardous substances shall be marked "KEEP OUT OF REACH OF CHILDREN."

170 Incandescent Units**170.1 Lamp replacement**

170.1.1 An incandescent type unit shall be marked in Form A-3 to indicate the proper wattage, type, and voltage of the replacement lamp(s).

Exception No. 1: The voltage is not required to be marked when the lamp(s) is intended for operation on a nominal 120 volt circuit.

Exception No. 2: When the minimum letter height required by Form A-3 is not accommodated because of the product's small physical size, the letter height is able to be reduced in accordance with 169.2.3.

170.1.2 The lamp identified in 170.1.1 shall be:

- a) The type and wattage tested; or
- b) Rated in accordance with the Temperature Test-Exempt Units requirements of Section 47.

170.1.3 The marking required in 170.1.1 shall be: "CAUTION:" "(TO REDUCE THE) RISK OF FIRE" – USE ____ WATT OR SMALLER, ____ VOLT, TYPE ____ LAMP(S)"; or equivalent. The lamp type shall be indicated by a drawing – see Figure 170.1.

Figure 170.1
General lamp type

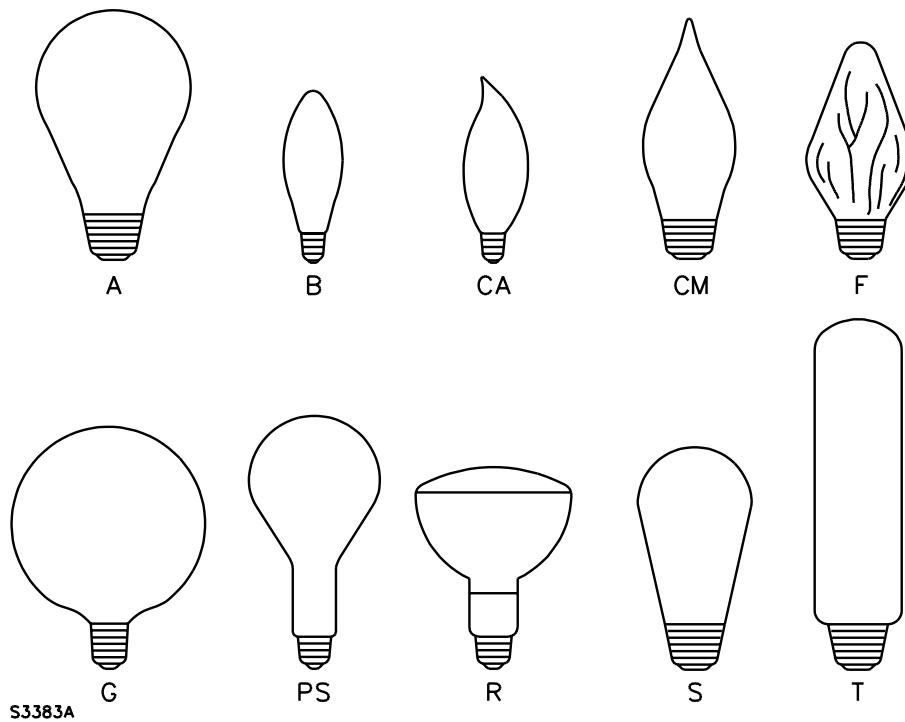

170.1.4 A portable luminaire intended for use with two or more incandescent lamps, all of which are of the same wattage, is able to be marked to indicate either the maximum-wattage lamp to be used or to indicate both the number of lamps and the maximum-wattage lamp. For a unit having lamps that are not all of the same wattage, the number of lamps of each wattage shall be indicated.

170.1.5 For a portable luminaire provided with a three-way lampholder, the marked maximum wattage for the lamp replacement marking specified in 170.1.1 shall be at least 100 watts.

170.2 Incandescent units shipped without lampshade

170.2.1 When a portable luminaire is not provided with a shade in accordance with 16.1, it shall be marked in Form C with instructions to indicate the minimum required shade dimensions in accordance with the temperature test-exempt requirements or the shade that it was tested with.

170.3 Removal of dust cover

170.3.1 A dust cover over the shade shall be marked in Form C "Remove cover before using unit" or the equivalent, where visible.

171 Tungsten Halogen Units

171.1 Lamp replacement – single envelope lamp

171.1.1 A portable luminaire intended for use with a tungsten-halogen lamp having a single envelope shall be marked in Form A-3 in accordance with 170.1 to indicate the proper wattage, type, and voltage of the replacement lamp(s).

171.1.2 A halogen torchiere unit intended for use with a single-ended lamp and without a guard as specified in 52.3.12 shall be marked in Form A-3: "WARNING – Risk of Fire – Use (1)___ W Maximum, Type (2)___ Single Envelope Tungsten Halogen Lamp That Is Marked On The Lamp Carton As Being Suitable For Use Without An Additional Shield." The blanks shall be filled in with:

- a) Test lamp wattage; and
- b) Lamp shape, symbol, and outline drawing.

When the lamp is a type not commonly available, with a shape and diameter other than the types specified in Table 125.2, the marking shall include the lamp manufacturer's name and ordering code. See 81.2.

171.2 Lamp replacement – double envelope lamp

171.2.1 A portable luminaire intended for use with a tungsten-halogen lamp having a double envelope shall be marked in accordance with 170.1 to indicate the proper wattage, type, and voltage of the replacement lamp(s).

Exception: Lamps having integral UV filters and containment barriers are able to be alternately marked in accordance with 171.2.2 or 171.2.4.

171.2.2 A portable luminaire intended for use with a medium base Type A style double envelope tungsten-halogen lamp or Type A incandescent lamp shall be marked in Form A-3 "CAUTION:" "Risk of Fire, Use _W Maximum, Type A or Medium Base Type A Style Double Envelope Tungsten Halogen Lamp That is Marked on the Bulb (Lamp) Carton as Being for use Without Additional Shield", or alternately CAUTION: "Risk of Fire – Use __W Maximum, Type A or Classified Tungsten Halogen Lamp", or equivalent.

171.2.3 The lamp identified in 171.2.2 shall be:

- a) The wattage tested; or
- b) Not exceed 100W and be rated in accordance with the Temperature Test-Exempt Units requirements of Section 47.

171.2.4 A portable luminaire equipped with a lamp other than a medium base double envelope tungsten halogen lamp that complies with the Exception to 52.2.1 or the Exception to 52.4.1 shall be marked in Form A-3 with the word "WARNING" or "CAUTION: Risk of Fire and Exposure to Excessive UV Radiation – Use ___W Maximum Double Envelope Tungsten Halogen Bulb (Lamp) That is Marked on the Lamp Carton As Being Suitable For Use Without an Additional Shield", or equivalent.

171.3 Risk of fire and injury warnings

171.3.1 A portable luminaire shall be marked in Form A-3 where visible during setup, or on a Form A label attached to the power-supply cord: "WARNING" "RISK OF FIRE/INJURY TO PERSONS. Keep away from combustibles. Unplug to change bulb (lamp). Do not touch bulb (lamp)", or the equivalent. This marking is able to be combined with other required marking.

Exception: When this requirement is not able to be used because of the product's small physical size and the power supply cord is not visible after installation, the marking is able to be provided in Form C.

171.3.2 A portable luminaire that is required to have a UV filter and not interlocked shall have the following marking added to 171.3.1: "Do not operate without complete bulb (lamp) enclosure in place or if lens is damaged."

171.3.3 When a portable luminaire employs a double pole switch, the marking required in 171.3.1 shall include the words "Turn off" and state "Turn off/Unplug to change bulb (lamp)."

171.3.4 When the marking in 171.3.1 is provided, the unit shall be marked in Form B adjacent to the switch to identify the off position.

171.3.5 A portable luminaire shall be marked in Form A-3 where visible during setup, or on a label in Form A attached to the power-supply cord with the word "WARNING" and the following or the equivalent: "Risk of FIRE. Do not place lamp where the overhead surface is closer than ____ feet to the portable luminaire." The blank shall be filled in with the spacing used between the portable luminaire and the overhead test surface during the Overhead Surface Test, 143.6. This marking is able to be combined with that in 171.3.1.

Exception No. 1: The marking is able to be in the form of a pictograph complying with the requirements of 169.4.

Exception No. 2: This marking is not required when the Overhead Surface Test, 143.6 is conducted with the portable luminaire mounted as close to the overhead test surface as the construction permits.

171.3.6 A tungsten-halogen portable floor unit with an open top design with the lamp facing upward, such as a torchiere style, shall be marked in Form A-3 with the word "WARNING" and the following or equivalent: "HOT SURFACE! TO AVOID RISK OF FIRE, DO NOT ALLOW CURTAINS AND OTHER COMBUSTIBLE MATERIALS TO COME IN CONTACT WITH THE LAMP." In addition, this same marking shall be in Form A on the pole, base, or power-supply cord. This marking may be combined with the marking in 171.3.1.

171.4 Five foot minimum mounting

171.4.1 A portable luminaire intended for mounting a minimum of 5 feet (1.5 m) above the floor in accordance with Exception No. 2 to 52.2.2 shall be marked in Form A-3 or provided with a Form A label on the power-supply cord with the word "WARNING" "Risk of FIRE/INJURY TO PERSONS. Install minimum 5 feet (1.5 m) above the floor", or equivalent. This marking is able to be combined with that in 171.5.1.

171.5 Date code

171.5.1 A halogen torchiere style unit shall be marked in Form B-1 with the date of manufacture in the following code:

ww yy

Where "ww" is week and "yy" is year.

172 Fluorescent Units

172.1 Lamp replacement

172.1.1 A portable luminaire that employs a compact fluorescent lamp shall be marked in Form A-3 to indicate the proper wattage and type of the replacement lamp.

Exception: The marking is not required to be provided when the portable luminaire employs a Class P ballast and the lampholder is keyed to accept a specific lamp wattage. The lampholder keying shall comply with Lamp Caps and Holders Together with Gauges for the Control of Interchangeability and Safety, IEC 60061-2.

172.1.2 The marking required in 172.1.1 shall be: "CAUTION" and "(TO REDUCE THE) RISK OF FIRE – USE ONLY ____ TYPE ____ WATTS LAMPS".

172.1.3 The lamp identified in 172.1.2 shall be:

- a) The type and wattage tested; or
- b) Rated per ballast used in accordance with the Temperature Test-Exempt Units requirements of Section 60.

173 High-Intensity-Discharge Units

173.1 Lamp replacement

173.1.1 A portable luminaire shall be marked in Form A-3 "Relamp with ___ watts type ___", where the blanks indicate the proper lamp wattage and ANSI designation of the replacement lamp. The lamp shall be wattage and type tested. See Table 173.1 for examples of ANSI designations.

Table 173.1
ANSI lamp designations

Wattage	Mercury vapor	Low pressure sodium	Metal halide	High pressure sodium
18	—	L69	—	—
35	—	L70	—	S76
40	H45	—	—	—
50	H45	—	—	S68
55	—	L71	—	—
70	—	—	M85	S62
75	H43	—	—	—
90	—	L72	—	—
100	H38	—	M90	S54
125	H42	—	—	—
135	—	L73	—	—
150	—	—	M81	S55 ^a
150	—	—	—	S56 ^b
175	H39	—	M57	—
180	—	L74	—	—
200	—	—	—	S66
250	H37	—	M58	S50
310	—	—	—	S67
400	H33	—	M59	S51
700	H35	—	—	—
750	—	—	M83	—
1000	H36 ^c	—	M47	S52
1000	H34 ^d	—	—	—
1500	—	—	M48	—

^a 55 volt lamp.
^b 100 volt lamp.
^c Low current lamp.
^d High current lamp.

173.1.2 When the replacement lamp in 173.1.1 does not have an ANSI designation, the portable luminaire shall be marked with the lamp wattage and lamp type, where the lamp type is indicated by metal halide (or MH), mercury vapor (or MV), or high pressure sodium (or HPS).

173.2 Double-ended metal halide lamp

173.2.1 A portable luminaire with a double-ended metal halide lamp without an integral outer glass envelope shall be marked in Form A-5 with the word "CAUTION" Risk of exposure to excessive ultraviolet (UV) radiation – Do not operate without complete lamp enclosure in place or if glass lens is damaged", or equivalent.

174 Cord and Chain Suspended Units

174.1 A portable luminaire not provided with the lengths of cord and chain required by 72.1.1 shall be marked in Form A-1 "For use in recreational vehicles only".

Exception: The marking is not required when the cord and chain are shortened in accordance with 34.3.

175 Portable Cabinet Lights

175.1 Identification

175.1.1 A cabinet light shall be marked in Form A-3 "Portable Cabinet Light."

175.2 Remote transformer

175.2.1 A portable cabinet light intended for connection to a remote transformer or power supply shall be marked in Form B-5, "For use with (Catalog Number) of transformer or power supply manufactured by (manufacturer of transformer or power supply)." Separately packaged transformers or power supplies shall be marked in Form A-1 with:

- a) Portable Cabinet Light Transformer or Power Supply;
- b) Electrical rating of secondary circuit in volts and amperes;
- c) The maximum number and wattage of each catalog number cabinet light that are able to be connected to the transformer or power supply;
- d) For use with (Catalog Number) portable cabinet light manufactured by (manufacturer of transformer or power supply).

175.3 Shortened cord

175.3.1 A plug provided on a shortened cord shall be marked "Use only with portable cabinet light accessory providing ten foot total cord length." Marking shall be provided on a Form C tag near the attachment plug.

175.4 Interconnecting receptacle

175.4.1 A NEMA Style 1-15, 1-15P, 5-15, or 5-15P receptacle provided on an interconnecting cord shall be marked "Use only for connection to portable cabinet lights" and shall include the maximum rated load in watts. Marking shall be provided on a Form A tag near the receptacle.

175.4.2 When the marking in 175.4.1 is provided, the interconnecting marking in 169.9.1 and 169.9.2 are not required.

176 Units for Use with Office Furnishings

176.1 A portable luminaire for use with office furnishings shall be marked in accordance with the applicable sections of the Standard and as indicated herein.

176.2 A portable luminaire shall be marked in Form B-5: "For use with office furnishings" or the equivalent.

176.3 A portable luminaire provided with a proprietary mounting system shall be marked in Form B-5 "Only for use with office furnishing systems identified by the manufacturer's instructions."

177 Convertible Units

177.1 In addition to the markings required elsewhere in this standard, a convertible unit shall be marked in accordance with Form B-1 to indicate that it is capable of being used as a fixed unit (luminaires) when used with the appropriate conversion kit. The marking shall be visible during installation, and shall include a catalog or the identifying number for the conversion kit.

177.2 The marking in 177.1 shall specify that the product is one of either an incandescent or a fluorescent, or HID unit (luminaire).

178 Interchangeable Units

178.1 Each base shall be marked in Form A-1 "CAUTION – To reduce the risk of fire and electric shock, use only lighting assemblies marked for use with ____ base." The blank space is to be filled in with the manufacturer's name and series or model number of the base.

Exception No. 1: The words "fixture assemblies" are able to be substituted for the words "lighting assemblies."

Exception No. 2: The marking is able to be worded to correlate with that required in 178.2.

178.2 A lighting assembly shall be marked in Form A-1 "CAUTION – To reduce the risk of fire and electric shock, use only with ____ base.": The blank is to be filled in with the manufacturer's name and series or model number of the base.

Exception: When the lighting assembly is marked in accordance with the Standard for Track Lighting Systems, UL 1574, it is not required to be additionally marked in accordance with this requirement.

178.3 A base designed only for use with mounting clips shall be marked in Form A-1 "For clip mounting only."

178.4 A base designed for ceiling mount only shall be marked in Form A-1 "For Ceiling Mount Only."

178.5 A base complying with the Exception to 97.3 shall be marked in Form A-1. "CAUTION: To avoid the risk of fire and personal injury, do not install less than 5 feet above the floor."

179 Track-Style Units

179.1 A track unit shall be marked in Form A-1: "CAUTION – To reduce the risk of fire or electric shock, use only lighting assemblies marked for use with ____ track"; and adjacent to this marking, "Do not extend the length of this track." The blank space shall be filled in with the manufacturer's name and series or model number of the track unit that the lighting assemblies are intended for use with.

Exception: The words "fixture assemblies" are able to be substituted for the words "lighting assemblies."

179.2 A lighting assembly shall be marked in Form A-1: "CAUTION – To reduce the risk of fire or electric shock, use only with _____ track." The blank space shall be filled in with the manufacturer's name and series or model number of the track unit that the lighting assemblies are to be used with.

Exception: A lighting assembly is not required to comply with this requirement when marked in accordance with the Standard for Track Lighting Systems, UL 1574.

179.3 A track unit designed for use only with mounting clips shall be marked in Form A-1: "For clip mounting only."

179.4 A track unit designed for ceiling mounting only shall be marked in Form A-1: "For Ceiling Mount Only."

180 Portable Luminaire Subassemblies

180.1 All markings required elsewhere in this standard shall be provided by the manufacturer. In addition, a catalog or model number shall be marked on the product.

180.2 All markings shall be applied to the product and all instructions shall be provided with the product in the subassembly packaging.

181 Work Light

181.1 A tungsten halogen work light shall be marked in accordance with this Section and Section 171 for Tungsten Halogen Units.

181.2 A work light marked for outdoor use only or wet locations shall also comply with the markings in Section 182 for Wet Location Use.

181.3 A work light that does not comply with the wet location use requirements shall be marked in Form A-3 "Dry Location Use."

181.4 A work light shall be marked in Form A-3 "Outdoor Use Only" when the portable luminaire is not provided with a housing guard in accordance with Exception No. 2 of 116.2.1.

181.5 A housing that operates above 90°C (194°F) shall be marked in Form A-3 where visible during use:

- a) "HOT SURFACE" in 1/8 inch (6.4 mm) high letters; or
- b) The symbol _____ which is the pictorial representation of hot surface and includes the word "HOT" within the triangle and "CAUTION" either within or adjacent to the triangle. The individual letters of the word "CAUTION" shall be not less than 1/8 inch (6.4 mm) in height.

181.6 A work light that is provided with an unassembled guard shall be marked in Form C on the hang tag with "CAUTION – Risk of Burns, Do not operate without guard. See assembly instructions."

181.7 A work light provided with a telescoping stand without a mechanical stop to prevent separation shall be marked in Form A-3 "Caution, risk of injury, do not extend work lights above alignment mark on pole."

182 Wet Location Use

182.1 A portable luminaire intended for use in wet locations shall be marked in Form A-1 "Suitable for Wet Location Use."

182.2 All wet location units shall be marked in Form A-1 "CAUTION: RISK OF ELECTRIC SHOCK, Do not use with extension cord near water or where water may accumulate. Keep lamp at least 16 feet from pools and spas. Keep plugs and receptacles dry." These portable luminaires shall also be marked "For use only on GFCI protected circuits."

182.3 The marking material for all markings shall be able to be used for wet locations.

PART IV

INSTRUCTIONS

183 General

183.1 Location

183.1.1 Required instructions shall be included on the portable luminaire, on the carton, on a tag on the power-supply cord, on a stuffer sheet, or by an equivalent means. See Form C.

183.2 Assembly instructions

183.2.1 A portable luminaire that requires mechanical assembly after shipment shall be marked in Form C with instructions for proper assembly. The instructions shall describe a method of assembling the lamp that does not introduce a risk of fire, electric shock, or injury to persons during or after its assembly.

183.3 Polarization instructions

183.3.1 A portable luminaire having a polarized plug shall be provided with instructions for use on the plug. The instructions shall be titled "IMPORTANT SAFETY INSTRUCTIONS" in letters not less than 3/16 inch (4.8 mm) high. Immediately following the title shall be the following text or the equivalent: "This portable luminaire has a polarized plug (one blade is wider than the other) as a feature to reduce the risk of electric shock. This plug will fit in a polarized outlet only one way. If the plug does not fit fully in the outlet, reverse the plug. If it still does not fit, contact a qualified electrician. Never use with an extension cord unless plug can be fully inserted. Do not alter the plug."

Exception: The words "portable luminaire" are able to be replaced by the word "product" or the equivalent.

183.4 Interconnected units

183.4.1 Instructions for interconnected unit use shall include at least the following:

- a) Voltage and current rating of portable luminaire;
- b) Maximum number of units to be interconnected; and
- c) Instructions for mounting including maximum distance between units to be interconnected.

183.5 Pin type attachment plug

183.5.1 When a pin-type attachment plug is provided in accordance with 32.4, the portable luminaire shall be provided with clear, illustrated instructions specifying proper attachment. The instructions shall include:

- a) A description of the plug and cord, including the means of identifying polarity;
- b) An explanation of why polarity is important;
- c) Instructions for assembly; and
- d) The polarization instructions detailed in 183.3.

183.6 Shortened cord

183.6.1 A product provided with a shortened (or no) power supply cord shall be provided with instructions specifying the correct mounting and intended use of the product. The instructions are able to be generic for a type or style of portable luminaire. A statement that the maximum distance to the receptacle (or between interconnected units, when applicable) is determined by the length of cord provided shall be included in the instructions. Alternatively, the maximum distance to the receptacle (or between interconnected units, when applicable) is able to be included in the instructions.

Exception: This requirement does not apply to shortened cords provided on portable cabinet lights.

183.7 Alternate supply connection

183.7.1 A product provided with an alternate power-supply connector in accordance with Alternate Power-Supply Connections, Section 34, shall be provided with markings and instructions consistent with the supply circuit for which it is intended to be used.

183.8 Attachment plugs complying with foreign standards

183.8.1 A product provided with an attachment plug in accordance with 34.1 shall be provided with instructions to conform with the standards of the country in which the product is intended to be used.

184 Incandescent Units

184.1 Units shipped without lampshade

184.1.1 When a portable luminaire is not provided with a shade in accordance with 16.1, it shall be marked in Form C with instructions for providing a shade usable for the marked maximum wattage and lamp type of the incandescent type unit that was temperature tested or in the lamp-to-shade dimensions specified in Temperature Test-Exempt Units, Section 47.

185 Tungsten-Halogen Units

185.1 A tungsten-halogen type unit shall be provided with instructions that include the items in the following list or equivalent statements for each item. The statements "INSTRUCTIONS PERTAINING TO A RISK OF FIRE, ELECTRIC SHOCK, [EXPOSURE TO EXCESSIVE UV RADIATION]^a OR INJURY TO PERSONS" and "IMPORTANT SAFETY INSTRUCTIONS" or the equivalent shall precede the list, and the statement "SAVE THESE INSTRUCTIONS" or the equivalent shall either precede or follow the list. All words shown entirely in upper case letters shall be in upper case letters or shall be emphasized to distinguish them from the rest of the text.

INSTRUCTIONS PERTAINING TO A RISK OF FIRE, ELECTRIC SHOCK, EXPOSURE TO EXCESSIVE UV RADIATION, OR INJURY TO PERSONS

IMPORTANT SAFETY INSTRUCTIONS

Lighted lamp is HOT:

WARNING – To reduce the risk of FIRE, ELECTRIC SHOCK, EXPOSURE TO EXCESSIVE UV RADIATION, OR INJURY TO PERSONS:

- 1) Turn off/unplug and allow to cool before replacing bulb (lamp).
- 2) Bulb (lamp) gets HOT quickly! Only contact switch/plug when turning on.
- 3) Do not touch hot lens, guard, or enclosure.^b
- 4) Do not remain in light if skin feels warm.
- 5) Do not look directly at lighted lamp.
- 6) Keep lamp away from materials that may burn.
- 7) Use only with a ____ watt or smaller bulb (lamp).^c
- 8) Do not touch the bulb (lamp) at any time. Use a soft cloth. Oil from skin may damage bulb (lamp).
- 9) Do not operate the portable luminaire with a missing or damaged guard, lamp containment barrier, or UV filter.^c

SAVE THESE INSTRUCTIONS

^aOnly required when a UV filter is required.

^bAn explanation, a picture, or a drawing of a lens, a guard, a lamp containment barrier, a UV filter, or an enclosure shall be provided so that the user is able to identify these parts on the lamp.

^cThe blank space represents a numerical value that is to be less than or equal to the tested lamp(s) wattage.

185.2 A halogen torchiere unit employing a lamp type not commonly available, with a shape and diameter other than the types specified in Table 125.2, shall include instructions on how to obtain replacement lamps directly from the manufacturer or distributor. See 171.1.2.

186 Surface Mounted Units

186.1 General

186.1.1 Installation instructions shall be provided with each surface mounted unit. The instructions shall detail the correct use of the mounting hardware provided with the portable luminaire and the proper means of mounting the unit.

186.2 Appliance mounting

186.2.1 A portable luminaire incorporating provisions for appliance mounting in accordance with 70.2 shall be provided with instructions to indicate the intended application and the intended means of mounting.

187 Cord and Chain Suspended Units

187.1 Installation instructions shall be provided with each portable luminaire. Clear instructions for the use of the mounting hardware, a caution that installation not be made on a radiant-heating ceiling, and, for swag units, a caution that the hooks are to engage the chain only and not the electric cord shall be included.

188 Portable Cabinet Lights

188.1 Installation instructions

188.1.1 General

188.1.1.1 Installation instructions shall be provided with each portable cabinet light and shall include the following items in 188.1.1.2, and additionally 188.1.3 – 188.1.6, as applicable. 188.1.4 and 188.1.6 are applicable only when the direct plug-in or remote power supply is marked as having a Class 2 output.

Exception: For bulk-packaged portable cabinet lights that are shipped to and installed by a furniture manufacturer, only one set of installation instructions is required per bulk shipping carton.

188.1.1.2 The intended use and mounting directions shall be included in the portable cabinet light installation instructions.

188.1.2 All units

188.1.2.1 Instructions required in 188.1.1.1 include, "CAUTION" and the following, "To reduce the risk of fire, electric shock, or injury to persons:

- a) Use only insulated staples or plastic ties to secure cords;
- b) Route and secure cords so that they will not be pinched or damaged when the cabinet is pushed to the wall;
- c) Position the portable cabinet light with respect to the cabinet so the lamp replacement markings are able to be read during relamping; and
- d) Not intended for recessed installation in ceilings, or soffits."

188.1.3 Surface mounted, non-Class 2

188.1.3.1 For surface mounted, non-Class 2 units, instructions shall include the installation requirements for all units in 188.1.2, and the following, or equivalent:

- a) "Not intended for surface installation inside built-in furnishings such as kitchen cabinets, china cabinets, or trophy cases;
- b) The portable cabinet light may be installed under a kitchen cabinet when the power supply cord is not concealed or run through openings in the cabinet;
- c) Do not conceal power supply cord (or power supply) inside a wall, ceiling, soffit, kitchen cabinet, or similar permanent structure; and
- d) Do not run the power supply cord through holes in walls, ceilings, or floors."

188.1.4 Surface mounted, provided with Class 2 power supply

188.1.4.1 For surface mounted units, provided with a Class 2 power supply, the instructions shall include the requirements for all units in 188.1.2, and the following, or equivalent:

- a) "The low voltage portable cabinet light may be installed inside or under a kitchen cabinet or other built-in furniture when:
 - 1) The low voltage Class 2 power supply is located outside the cabinet and is not concealed; and
 - 2) The line voltage power supply cord is not concealed or run through openings in the cabinet, walls, ceilings, or floors. This requirement does not apply to the wiring between the cabinet light and the power unit.
- b) Do not conceal line voltage power supply cord or power supply inside a wall, ceiling, soffit, kitchen cabinet, or similar permanent structure;
- c) Do not run line voltage power supply cord through holes in walls, ceilings, or floors."

188.1.5 Recessed mounted, non-Class 2

188.1.5.1 For recessed mounted, non-Class 2 units, the instructions shall include the installation requirements for all units in 188.1.2, and the following, or equivalent:

- a) "Not intended for recessed installation in built-in furnishings such as a kitchen cabinet, china cabinet, or trophy case;
- b) Do not conceal power supply cord inside a wall, ceiling, soffit, kitchen cabinet, or similar permanent structure;
- c) Do not run line voltage power supply cord through holes in walls, ceilings, or floors."

188.1.6 Recessed mounted, provided with Class 2 power supply

188.1.6.1 For recessed mounted units, provided with Class 2 power supply, installation instructions shall include installation requirements for all units in 188.1.2, and the following, or equivalent:

- a) "The low voltage portable cabinet light may be installed in a kitchen cabinet or other built-in furniture when:
 - 1) The low voltage power supply is located outside the cabinet and is not concealed; and
 - 2) The line voltage power supply cord is not concealed or run through cabinet openings. This requirement does not apply to the wiring between the cabinet light and the power unit.
- b) Do not conceal line voltage power supply cord or power supply inside a wall, ceiling, soffit, kitchen cabinet, or similar permanent structure;
- c) Do not run line voltage power supply cord through holes in walls, ceilings, or floors."

188.2 Markings

188.2.1 A portable cabinet light tested in other than the standard 12 inch by 12 inch by 12 inch (0.3 m by 0.3 m by 0.3 m) test box shall be marked in Form C with the word "CAUTION" and the following or the equivalent: "To prevent the risk of fire, do not install closer than ^a inches to cabinet wall or in a compartment smaller than ^a inches by ^a inches by ^a inches." The blanks are to be filled in with the parameters of the temperature test.

^aMetric dimensions may also be included.

188.2.2 A pot style portable cabinet light intended only for use in a cabinet where the cabinet is not enclosed at the top shall be marked in Form C "CAUTION, Risk of Fire, Install only in cabinets where the top of the cabinet light housing is not enclosed" or "CAUTION, Risk of fire, Install only in open top cabinets."

189 Units for Use with Office Furnishings

189.1 Each portable luminaire supplied with a proprietary mounting system shall be provided with assembly and mounting instructions.

189.2 The instructions shall identify the manufacturer and system or panel designation of the intended office furnishing applications.

190 Convertible Units

190.1 General

190.1.1 Instructions shall be provided for the convertible unit and shall indicate that the grounding wire, when not integral with the power-supply cord, is to be cut off at the point closest to the unit and discarded when the product is not used as a fixed unit (luminaire).

190.2 Swag to chandelier installation

190.2.1 All instructions for mounting as a swag type unit and clear instructions for converting to a chain-suspended type fixed unit (fixture) shall be provided. Items such as:

- a) The means for opening the chain at the desired length;
- b) Cutting the cord and grounding conductor at least 12 inches (304.8 mm) beyond end of chain; and
- c) Proper preparation and connection of the leads and grounding conductor shall be included.

190.3 Surface mount installation

190.3.1 Clear instructions for mounting as a portable unit and clear instructions for converting to a surface-mount fixed unit (fixture) shall be provided. Items such as:

- a) Cutting the cord and grounding conductor so that they are at least 6 inches (152.4 mm) long within an outlet box; and
- b) Proper preparation and connection of the leads and grounding conductor shall be included.

191 Track-Style Units

191.1 Instructions as specified in 191.2 and 191.3 shall be provided with each track section. The height of lettering in the text and illustrations shall be as follows:

- a) The phrases "IMPORTANT SAFETY INSTRUCTIONS" and "SAVE THESE INSTRUCTIONS" shall be in letters at least 3/16 inch (4.8 mm).
- b) All other lettering shall be at least 1/16 inch (1.6 mm) high.

191.2 The instructions shall include the information specified in 191.3. The information is able to be reworded or combined in any other as long as the intent is unchanged. The wording is able to be supplemented by additional drawings or cartoons.

191.3 The instructions shall include the following information:

IMPORTANT SAFETY INSTRUCTIONS

1. Read all instructions.
2. Do not install this track in a damp or wet location.
3. Do not install any part of track less than 5 feet above the floor.
4. Do not install any lighting assembly closer than 6 inches from any curtain or similar combustible material.
5. Do not attempt to energize anything other than lighting assemblies on the track. To reduce the risk of fire and electric shock, do not attempt to connect power tools, extension cords, appliances, and the like to the track.

SAVE THESE INSTRUCTIONS

192 Portable Luminaire Subassemblies

192.1 An assembly instruction sheet shall be provided with each portable luminaire subassembly. (These instructions are able to be marked on the carton or container.) The instructions shall contain:

- a) Clear identification of the individual parts;
- b) A list and complete description of all parts not provided such as a bottle or vase;
- c) Assembly instructions to be followed when assembling the parts; and
- d) Any instructions required elsewhere in this standard. In addition, a warning shall be provided, in letters minimum 1/4 inch (6.4 mm) high stating "WARNING" and the following or equivalent: "Deviation from the assembly instructions may result in a risk of fire or electric shock."

192.2 The instructions shall explain such items as:

- a) Strain relief;
- b) Polarization and polarized plug;
- c) Lamp replacement marking;
- d) Stability of finished product; and
- e) Information concerning correct threading of wire through tubing and across edges.

192.3 When the subassembly is intended for rewiring existing products, the instructions shall include an indication of the type of product (example: floor or table) and the physical size of the portable luminaire for which the subassembly is appropriate with respect to the length of cord provided. Complete instructions concerning the removal of old wiring and components (when required) shall be provided.

193 Wet Location Use

193.1 In addition to the applicable instructions in elsewhere in this Standard, instructions for wet locations use shall include an important safety instruction section which shall include the items specified in 193.2.

193.2 The following instructions shall be separated in format from the other instructions and shall appear before any operating instructions. The phrases "Read All Instructions" and "SAVE THESE INSTRUCTIONS" shall appear and shall be the first and last items, respectively. The phrase "Read All Instructions" shall be preceded by the statement "WARNING: When using outdoor use portable luminaires, basic safety precautions should always be followed to reduce the risk of fire, electric shock, and personal injury, including the following..." Equivalent wordings in equally definitive terminology are able to be used, except for the signal word. The instructions shall be legible and shall contrast with the background.

- a) Use only three-wire outdoor extension cords that have three-prong grounding plugs and grounding receptacles that accept the appliance's plug.
- b) Ground Fault Circuit Interrupter (GFCI) protection is to be provided on the circuit(s) or outlet(s) to be used for the wet location portable luminaire. Receptacles are available having built-in GFCI protection and are able to be used for this measure of safety.

- c) Use only with an extension cord for outdoor use, such as an extension cord of cord type SW, SW-A, SOW, SOW-A, STW, STW-A, STOW, STOW-A, SJW, SJW-A, SJOW, SJOW-A, SJTW, SJTW-A, or SJTOW, SJTOW-A.

PART V

MANUFACTURING AND PRODUCTION TESTS

194 Manufacturing and Production Tests

194.1 General

194.1.1 The following test described in 194.2 applies to portable luminaires having accessible dead metal parts or low circuits. Compliance criteria is described in 194.3.

194.1.2 A dielectric test shall also be conducted on portable luminaire subassemblies that are shipped with factory made wiring connections.

194.2 Test method

194.2.1 Each portable luminaire shall have a routine production-line test and the application of a potential as specified in Table 194.1 between:

- a) Primary wiring, including connected components, and accessible dead metal parts of a portable luminaire that are likely to become energized, including those parts that are accessible only during relamping; and
- b) Primary wiring and accessible low-voltage – 42.4 volts peak or less – metal parts, including terminals.

Exception: The test is not required to be conducted on a portable luminaire with all components mounted in an enclosure of nonconductive material when the component is not touched or handled in normal use and when the mounting screw or other mounting means is not exposed on the exterior of the enclosure.

194.2.2 The production line test is to be in accordance with either condition A or B of Table 194.1.

**Table 194.1
Production-line test conditions**

Condition	Application time seconds	Applied potential	
		40 – 70 hertz	DC
A	60	1000	1414
B	1	1200	1697

194.2.3 The test shall be conducted when the portable luminaire is complete – fully assembled. It is not intended that the unit be unwired, modified, or disassembled for the test.

Exception No. 1: Parts such as shades, diffusers, and similar components that interfere with performance of the test are not required to be in place.

Exception No. 2: The test is able to be conducted before final assembly when the test represents that for the completed portable luminaire.

Exception No. 3: When a portable luminaire employs a solid-state component that is not relied upon to reduce the risk of electric shock, and is capable of being damaged by the dielectric potential, the test is to be conducted before the component is electrically connected. In this case, a sample is to be selected at random from production each day and tested at the potential specified in 194.2.2. The circuitry is to be rearranged as required for the purpose of the test to reduce the risk of solid-state-component damage while retaining the representative dielectric stress of the circuit.

194.2.4 The test equipment shall include a transformer having a sinusoidal output, a means of indicating the test potential, and an audible or visual indication of breakdown. In the event of breakdown, manual reset of an external switch or an automatic reject of the unsatisfactory portable luminaire under test is required.

194.2.5 When the output of the test-equipment transformer is less than 500 volt-amperes, the equipment shall include a voltmeter in the output circuit to directly indicate the test potential.

194.2.6 When the output of the test equipment transformer is 500 volt-amperes or larger, the test potential is to be indicated by:

- a) A voltmeter in the primary circuit or a tertiary-winding circuit;
- b) By a selector switch marked to indicate the test potential; or
- c) By a marking in a readily visible location to indicate the test potential of equipment having a single test-potential output.

When a marking is used without an indicating voltmeter, the equipment shall include a positive means, such as power-on lamp, to indicate that the manually reset switch has been reset following a tripout.

194.2.7 Test equipment other than that described in 194.2.4 and 194.2.6 is able to be used when found to accomplish the intended factory control.

194.2.8 During the test, the primary switch is to be in the on position, both sides of primary circuit of the portable luminaire are to be connected together and to one terminal of the test equipment, and the second test-equipment terminal is to be connected to the accessible dead metal.

Exception No. 1: A portable luminaire (resistive, high-impedance winding, or similar components) having circuitry not subject to excessive secondary-voltage buildup in case of electrical breakdown during the test is able to be tested:

- a) With a single-pole primary switch when used, in the off position; or*
- b) With only one side of the primary circuit connected to the test equipment when the primary switch is in the on position, or when a primary switch is not used.*

Exception No. 2: The primary switch is not required to be in the on position when the testing means applies full test potential between primary wiring and dead metal parts with the switch not in the on position.

194.3 Test results

194.3.1 As a result of the test specified in 194.2, there shall be no electrical breakdown.

195 Polarity Test

195.1 General

195.1.1 The following test described in 195.2 applies to all portable luminaires provided with a polarized attachment plug of the 2-wire parallel-blade type. Compliance criteria is described in 195.3.

195.2 Test method

195.2.1 Each product shall be checked as routine production-line test to verify that there is electrical continuity between the grounded supply-circuit conductor of the attachment plug – wide blade of a 2-wire type – and the part of the product that is intended to be connected to the grounded supply-circuit conductor of the attachment plug (for example, screw shell of an incandescent lampholder). The continuity shall be determined either visually or through the use of an electrical test. Equivalently, continuity is able to be verified between the ungrounded supply-circuit conductor of the attachment plug and the part of the product that is intended to be connected to the ungrounded conductor (for example, the center contact of an incandescent lampholder).

195.3 Test results

195.3.1 The results meet the intent of the requirement when there is electrical continuity.

196 Continuity of Grounding Connection Test**196.1 General**

196.1.1 The following test described in 196.2 applies to all portable luminaires provided with an attachment plug of the 3-wire grounded type. Compliance criteria is described in 196.3.

196.2 Test method

196.2.1 Each product provided with a grounding attachment plug shall be tested for electrical continuity between the grounding blade of the attachment plug and all conductive parts that are accessible – only those parts that pose a risk of electric shock. Electrical continuity shall be maintained and verified as a routine production-line test.

196.2.2 The continuity shall be determined by the use of an indicating device, either audible or visual, such as an ohmmeter or a battery-and-buzzer combination.

196.3 Test results

196.3.1 The results meet the intent of the requirement when there is electrical continuity.

No Text on This Page

APPENDIX A

Standards for Components

Standards under which components of the products covered by this standard are evaluated include the following:

Title of Standard – UL Standard Designation

Attachment Plugs and Receptacles – UL 498
Ballasts, Fluorescent-Lamp – UL 935
Class 2 Power Units – UL 1310
Cord Sets and Power-Supply Cords – UL 817
Equipment Wiring Terminals for Use With Aluminum and/or Copper Conductors – UL 486E
Flexible Cord and Fixture Wire – UL 62
Fuseholder – UL 512
Lampholders, Edison-Base – UL 496
Lampholders, Starters, and Starter Holders for Fluorescent Lamps – UL 542
Luminaires – UL 1598
Marking and Labeling Systems – UL 969
Office Furnishing – UL 1286
Plastic Materials for Parts in Devices and Appliances, Tests for Flammability of – UL 94
Polymeric Materials – Fabricated Parts – UL 746D
Polymeric Materials – Long Term Property Evaluation – UL 746B
Polymeric Materials – Short Term Property Evaluation – UL 746A
Polymeric Materials – Use in Electrical Equipment Evaluations – UL 746C
Printed-Wiring Boards – UL 796
Protection for Motors, Overheating – UL 2111
Protectors for Use in Electrical Equipment, Supplementary – UL 1077
Sleeving, Coated Electrical – UL 1441
Stage and Studio Lighting Units – 1573
Switches, General Use Snap – UL 20
Switches, General-Use – UL 1054
Tape, Electrical Insulating – 510
Terminal Blocks – UL 1059
Terminals, Electrical Quick-Connect – UL 310
Thermal Cutoffs for Use in Electrical Appliances and Components – UL 1020
Toys, Electric – UL 696
Track Lighting Systems – UL 1574
Transformers, Class 2 and Class 3 – UL 1585
Transformers and Motor Transformers for Use in Audio-, Radio-, and Television-Type Appliances – UL 1411
Transformers, Specialty – UL 506
Tubing, Extruded Insulating – UL 224
Tubing for Electric Wiring, Flexible Nonmetallic – UL 3
Wire Connectors and Soldering Lugs for Use With Copper Conductors – UL 486A
Wire Connectors, Splicing – UL 486C
Wires and Cables, Rubber-Insulated – UL 44
Wires and Cables, Thermoplastic-Insulated – UL 83
Wires and Cables With Varnished-Cloth Insulation – UL 133

No Text on This Page