

UL 2054

ISBN 0-7629-0164-0

Household and Commercial Batteries

Underwriters Laboratories Inc. (UL)
333 Pfingsten Road
Northbrook, IL 60062-2096

UL Standard for Safety for Household and Commercial Batteries, UL 2054

First Edition, Dated May 29, 1997

Revisions: This Standard contains revisions through and including February 27, 1998 .

Text that has been changed in any manner is marked with a vertical line in the margin. Changes in requirements are marked with a vertical line in the margin and are followed by an effective date note indicating the date of publication or the date on which the changed requirement becomes effective.

UL is in the process of converting its Standards for Safety to the Standard Generalized Markup Language (SGML), and implementing an SGML compliant document management and publishing system. SGML - an international standard (ISO 8879-1986) - is a descriptive markup language that describes a document's structure and purpose, rather than its physical appearance on a page. Significant benefits that will result from UL's use of SGML and these new systems include increased productivity, reduced turnaround times, and data and information consistency, reusability, shareability, and portability. However, the fonts, pagination, and general formatting of UL's new electronic publishing system differ from that of UL's previous publishing system. Consequently, when revision pages are issued for a Standard with the new publishing system, these differences may result in the printing of pages on which no requirements have been changed - these additional pages result from relocation of text due to repagination and reformatting of the Standard with the new publishing system.

Announcement Bulletin(s): This Standard contains the announcement bulletin(s) dated April 29, 1999. The announcement bulletin is located at the end of the Standard (after the adoption bulletin(s)).

The revisions dated February 27, 1998 include a reprinted title page (page1) for this Standard.

The master for this Standard at UL's Northbrook Office is the official document insofar as it relates to a UL service and the compliance of a product with respect to the requirements for that product and service, or if there are questions regarding the accuracy of this Standard.

UL's Standards for Safety are copyrighted by UL. Neither a printed copy of a Standard, nor the distribution diskette for a Standard-on-Diskette and the file for the Standard on the distribution diskette should be altered in any way. All of UL's Standards and all copyrights, ownerships, and rights regarding those Standards shall remain the sole and exclusive property of UL.

All rights reserved. No part of this publication may be reproduced, stored in a retrieval system, or transmitted in any form by any means, electronic, mechanical photocopying, recording, or otherwise without prior permission of UL.

Revisions of UL Standards for Safety are issued from time to time. A UL Standard for Safety is current only if it incorporates the most recently adopted revisions.

UL provides this Standard "as is" without warranty of any kind, either expressed or implied, including but not limited to, the implied warranties of merchantability or fitness for any purpose.

In no event will UL be liable for any special, incidental, consequential, indirect or similar damages, including loss of profits, lost savings, loss of data, or any other damages arising out of the use of or the inability to use this Standard, even if UL or an authorized UL representative has been advised of the possibility of such damage. In no event shall UL's liability for any damage ever exceed the price paid for this Standard, regardless of the form of the claim.

UL will attempt to answer support requests concerning WordPerfect, Envoy, and Standards-on-Diskette. However, this support service is offered on a reasonable efforts basis only, and UL may not be able to resolve every support request. UL supports a Standards-on-Diskette only if it is used under the conditions and operating systems for which it is intended. UL's support policies may change from time-to-time without notification.

UL reserves the right to change the format, presentation, file types and formats, delivery methods and formats, and the like of both its printed and electronic Standards without prior notice.

Standards-on-Diskette purchasers agree to defend, indemnify, and hold UL harmless from and against any loss, expense, liability, damage, claim, or judgement (including reasonable attorney's fees) resulting from any error or deviation introduced while purchaser is storing a Standard-on-Diskette on the purchaser's computer system.

If a single-user version Standards-on-Diskette was purchased, one copy of this Standard may be stored on the hard disk of a single personal computer, or on a single LAN file-server or the permanent storage device of a multiple-user computer in such a manner that this Standard may only be accessed by one user at a time and for which there is no possibility of multiple concurrent access. The original distribution diskette should be stored in a safe place.

If a multiple-user version Standards-on-Diskette was purchased, one copy of the Standard may be stored on a single LAN file-server, or on the permanent storage device of a multiple-user computer. The number of concurrent users shall not exceed the number of users authorized for the Standards-on-Diskette version. The original distribution diskette should be stored in a safe place.

Standards-on-Diskette are intended for on-line use, such as for viewing the requirements of a Standard, conducting a word search, and the like. Only one copy of the Standard may be printed from each single-user version of a Standards-on-Diskette. Only one copy of the Standard may be printed for each authorized user of a multiple-user version of a Standards-on-Diskette. An employee of an organization purchasing a Standard-on-Diskette can make a copy of the page or pages being viewed for their own fair and/or practical internal use. Because of differences in the computer/software/printer setup used by UL and those of Standards-on-Diskette purchasers, the printed copy obtained by a purchaser may not look exactly like the on-line screen view or the printed Standard.

The requirements in this Standard are now in effect, except for those paragraphs, sections, tables, figures, and/or other elements of the Standard having future effective dates as indicated in the note following the affected item. The prior text for requirements that have been revised and that have a future effective date are located after the Standard, and are preceded by a "SUPERSEDED REQUIREMENTS" notice.

New product submittals made prior to a specified future effective date will be judged under all of the requirements in this Standard including those requirements with a specified future effective date, unless the applicant specifically requests that the product be judged under the current requirements. However, if the applicant elects this option, it should be noted that compliance with all the requirements in this Standard will be required as a condition of continued Listing and Follow-Up Services after the effective date, and understanding of this should be signified in writing.

This Standard consists of pages dated as shown in the following checklist:

Page	Date
1-2.....	February 27, 1998
2A-3.....	April 29, 1999
4-14.....	May 29, 1997
15.....	February 27, 1998
16.....	May 29, 1997
17-18B.....	February 27, 1998
19-20.....	May 29, 1997
21-22.....	April 29, 1999

No Text on This Page

MAY 29, 1997

(Title Page Reprinted: February 27, 1998)

1

UL 2054

Standard for Household and Commercial Batteries

First Edition

May 29, 1997

An effective date included as a note immediately following certain requirements is one established by Underwriters Laboratories Inc.

Revisions of this Standard will be made by issuing revised or additional pages bearing their date of issue. A UL Standard is current only if it incorporates the most recently adopted revisions, all of which are itemized on the transmittal notice that accompanies the latest set of revised requirements.

ISBN 0-7629-0164-0

COPYRIGHT © 1998 UNDERWRITERS LABORATORIES INC.

No Text on This Page

CONTENTS

FOREWORD	4
-----------------------	---

INTRODUCTION

1 Scope	5
2 General	5
2.1 Units of measurement	5
2.2 Terminology	6
3 Glossary	6

CONSTRUCTION

4 General	7
4.1 Casing	7
4.2 Electrolyte	7

PERFORMANCE

5 General	7
6 Samples	8
7 Important Test Considerations	10
8 Temperature Measurements	10

ELECTRICAL TESTS

9 Short-Circuit Test	10
10 Abnormal Charging Test	11
11 Abusive Overcharge Test	11
12 Forced-Discharge Test	12
13 Limited Power Source Test	12

MECHANICAL TESTS

14 Crush Test	13
15 Impact Test	13
16 Shock Test	15
17 Vibration Test	15

BATTERY ENCLOSURE TESTS

18 General	15
19 250 lb. Crush Test	16
20 Mold Stress Relief Test	16
21 Drop Impact Test	16

FIRE EXPOSURE TESTS

22 Test For Flaming Particles	16
23 Projectile Test	18A

ENVIRONMENTAL TESTS

24 Heating Test20
25 Temperature Cycling Test20

MARKING

26 General20

No Text on This Page

FOREWORD

A. This Standard contains basic requirements for products covered by Underwriters Laboratories Inc. (UL) under its Follow-Up Service for this category within the limitations given below and in the Scope section of this Standard. These requirements are based upon sound engineering principles, research, records of tests and field experience, and an appreciation of the problems of manufacture, installation, and use derived from consultation with and information obtained from manufacturers, users, inspection authorities, and others having specialized experience. They are subject to revision as further experience and investigation may show is necessary or desirable.

B. The observance of the requirements of this Standard by a manufacturer is one of the conditions of the continued coverage of the manufacturer's product.

C. A product which complies with the text of this Standard will not necessarily be judged to comply with the Standard if, when examined and tested, it is found to have other features which impair the level of safety contemplated by these requirements.

D. A product employing materials or having forms of construction which conflict with specific requirements of the Standard cannot be judged to comply with the Standard. A product employing materials or having forms of construction not addressed by this Standard may be examined and tested according to the intent of the requirements and, if found to meet the intent of this Standard, may be judged to comply with the Standard.

E. UL, in performing its functions in accordance with its objectives, does not assume or undertake to discharge any responsibility of the manufacturer or any other party. The opinions and findings of UL represent its professional judgment given with due consideration to the necessary limitations of practical operation and state of the art at the time the Standard is processed. UL shall not be responsible to anyone for the use of or reliance upon this Standard by anyone. UL shall not incur any obligation or liability for damages, including consequential damages, arising out of or in connection with the use, interpretation of, or reliance upon this Standard.

F. Many tests required by the Standards of UL are inherently hazardous and adequate safeguards for personnel and property shall be employed in conducting such tests.

INTRODUCTION

1 Scope

1.1 These requirements cover secondary (rechargeable) batteries for use as power sources in products. These batteries consist of either a single electrochemical cell or two or more cells connected in series, parallel, or both, that convert chemical energy into electrical energy by chemical reaction.

1.2 These requirements are intended to reduce the risk of fire or explosion when batteries are used in a product. The proper use of these batteries in a particular application is dependent on their use in a complete product that complies with the requirements applicable to such a product.

1.3 These requirements are intended to cover batteries for general use. These requirements do not apply to batteries designed for use in a product where the combination of the battery and the product are covered by requirements in the product standard, such as the Standard for Portable Electric Tools, UL 745.

1.4 These requirements are also intended to reduce the risk of injury to persons due to fire or explosion when batteries are removed from a product to be transported, stored, or discarded.

1.5 These requirements cover cells, up to 10 amp hours in capacity, and battery packs constructed using these cells.

1.6 These requirements do not cover the toxicity risk that results from the ingestion of a battery or its contents, nor the risk of injury to persons that occurs if a battery is cut open to provide access to its contents.

1.7 Batteries containing lithium metal, lithium alloy or lithium ion shall also meet the requirements in the Standard for Lithium Batteries, UL 1642.

1.8 A product that contains features, characteristics, components, materials, or systems new or different from those covered by the requirements in this standard, and that involves a risk of fire, electric shock, or injury to persons shall be evaluated using the appropriate additional component and end-product requirements as determined necessary to maintain the acceptable level of safety as originally anticipated by the intent of this standard. A product whose features, characteristics, components, materials, or systems conflict with specific requirements or provisions of this standard cannot be judged to comply with this standard. Where considered appropriate, revision of requirements shall be proposed and adopted in conformance with the methods employed for development, revision, and implementation of this standard.

2 General

2.1 Units of measurement

2.1.1 When a value for measurement is followed by a value in other units in parentheses, the first stated value is the requirement.

2.2 Terminology

2.2.1 The term "battery(ies)" shall refer to single or multicell batteries.

3 Glossary

3.1 For the purpose of these requirements the following definitions apply.

3.2 BATTERY – (1) A single cell, or (2) a group of cells connected together either in a series or parallel configuration.

3.3 BATTERY, SECONDARY – A battery that is intended to be discharged and recharged many times in accordance with the manufacturer's recommendations.

3.4 CELL – A single electrochemical cell containing a positive and negative electrode.

3.5 COMPONENT, CURRENT-LIMITING – Any component employed to limit current during abnormal conditions. Current-limiting components include resistors, fuses, or PTC thermistor type devices.

3.6 CURRENT, ABNORMAL CHARGING – Charging current to a cell or battery under fault condition.

3.7 COMPONENT, TEMPERATURE-LIMITING – Any component used to limit temperature during abnormal conditions. Temperature-Limiting Components include thermal protectors and thermal cutoffs.

3.8 DISCHARGE, FORCED – Discharge of a battery by connection in series with an external power source so as to drive the battery into polarity reversal.

3.9 DISCHARGED, FULLY – A condition of battery energy potential. A battery is considered fully discharged when the closed circuit voltage is less than 0.2 volts, when the battery is connected to a 100-ohm resistive load and the short-circuit current has been reduced to less than 1 milliampere.

3.10 EXPLOSION – A condition that occurs when the cell or battery contents are forcibly expelled and the cell or battery casing is torn or split into two or more pieces.

3.11 VENTING – A condition that occurs when the battery or cell electrolyte is emitted as liquid, droplets, or vapor from a designed vent or through a seal.

3.12 PROTECTIVE DEVICES – A device such as fuses, diodes and current limiters which stop the current flow, block the current flow in one direction or limit the current flow in an electrical circuit.

3.13 RATED CAPACITY – The capacity, in ampere-hours, of a cell or battery as measured by subjecting it to a load, temperature and voltage cutoff point specified by the manufacturer.

3.14 C₅ AMP RATE – The current, in amperes, that a cell or battery can be discharged at for 5 hours to the voltage cut off point specified by the manufacturer.

3.15 SHORT CIRCUIT – A direct connection between positive and negative terminals of a cell or battery that provides a virtual zero resistance path for current flow.

CONSTRUCTION

4 General

4.1 Casing

4.1.1 The casing of a battery shall have the strength and rigidity required to resist the possible abuses, that it is exposed to during its intended use, in order to reduce the risk of fire or injury to persons.

4.1.2 The casing of a battery shall be rigid enough to prevent flexing. A tool providing the mechanical advantage of a pliers, screwdriver, hacksaw, or similar tool, shall be the minimum mechanical capability required to open the casing.

Exception No. 1: This requirement does not apply to a cell or battery containing electrodes with less than 0.04g (0.0014 ounces) of active mass.

Exception No. 2: For larger cells or batteries where repeated flexing or tearing of the case does not result in leakage as defined in Section 5 or heating of the battery to temperatures exceeding 60°C (140°F), this requirement does not apply.

4.2 Electrolyte

4.2.1 A battery shall not contain pressurized vapor or liquid that sprays materials into the eyes when the battery casing is punctured with a grinding wheel under laboratory conditions at a temperature of $23 \pm 2^\circ\text{C}$ ($73 \pm 3.6^\circ\text{F}$).

PERFORMANCE

5 General

5.1 Batteries are to be tested as described in Sections 9 through 25. Section 12, Forced-Discharge Test, is applicable only to cells intended to be used in multicell applications, such as battery packs. The Battery Enclosure Tests, Sections 18 – 21 (including the 250 Lb. Crush, Mold Stress Relief, and Drop Impact Tests) are intended only for batteries that have a plastic outer enclosure.

5.2 In most cases cells and/or batteries shall not explode or catch fire as a result of the tests in this standard. For the Shock Test, Section 16, Vibration Test, Section 17, 250lb. Crush Test, Section 19, Mold Stress Relief Test, Section 20, Drop Impact Test, Section 21, and the Temperature Cycling Test, Section 25 the samples shall also not vent or leak. For these tests unacceptable leakage is deemed to have occurred when the resulting mass loss exceeds the values shown in Table 5.1, Venting and Leakage Mass Loss Criteria.

Table 5.1
Venting and leakage mass loss criteria

Mass of cell or battery	Maximum Mass % Loss
Not more than 1 gram	0.5
More than 1.0 gram but not more than 5.0 gram	0.2
More than 5.0 gram	0.1

5.3 When a cell or battery fails to meet the criteria of any of the tests in this standard it may be eligible for use in applications where it is not exposed to or protected from conditions shown to cause fire, explosion or leakage. Specific precautions must be taken for the cells and or batteries to be acceptable for use in particular end product devices.

5.4 Certain end product devices require that the power output of a battery be limited. The Limited Power Source Test described in Section 13 is to be used to determine whether a cell or battery is suitable in such applications.

6 Samples

Section 6 effective May 29, 1998

6.1 Fresh cells or batteries are to be used for the tests described in Sections 9 – 25. The number of samples to be used in each test is shown in Table 6.1. When a group of cells or batteries of different sizes, but similar chemistries is involved, specified selected sizes representative of the range are to be tested.

Table 6.1
Number of batteries to be used in each test

Test	Section	Number of fresh batteries
Electrical Tests		
Short-Circuit	9	
at room temp.		5
at 60°C (140°F)		5
Abnormal Charge	10	5
Abusive Overcharge	11	5
Forced-Discharge	12	5
Limited Power Source	13	3
Mechanical Tests		
Crush	14	5
Impact	15	5
Shock	16	5
Vibration	17	5
Battery Enclosure Tests		
250 lb. Crush	19	3
Mold Stress Relief	20	3
Drop Impact	21	3
Fire Exposure Tests		
Test for Flaming Particles	22	5
Projectile	23	5
Environmental Tests		
Heating	24	5
Temperature Cycling	25	5

6.2 All batteries shall be fully charged prior to testing except for the samples to be subjected to the Abnormal Charge and Abusive Overcharge Tests.

7 Important Test Considerations

7.1 As some batteries explode in the tests described in Sections 9 – 25, it is important that personnel be protected from the flying fragments, explosive force, sudden release of heat, chemical burns, and noise results from such explosions. The test area is to be well ventilated to protect personnel from possible harmful fumes or gases.

7.2 The temperatures on the surface of the battery casings shall be monitored during the tests described in Sections 9, 11, 14, and 15. All personnel involved in the testing of batteries are to be instructed never to approach a battery while the surface temperature exceeds 90°C (194°F).

7.3 The tests described in Section 22 and 23, Test for Flaming Particles and the Projectile Test, shall be conducted in a room separate from the observer.

8 Temperature Measurements

8.1 Temperatures are to be measured by thermocouples consisting of wires not larger than No. 24 AWG (0.21 mm²) and not smaller than No. 30 AWG (0.05 mm²) and a potentiometer-type instrument.

8.2 The temperature measurements on the batteries are to be made with the measuring junction of the thermocouple held tightly against the outer casing of the battery.

ELECTRICAL TESTS

9 Short-Circuit Test

9.1 Each test sample battery, in turn, is to be short-circuited by connecting the positive and negative terminals of the battery with copper wire having a maximum resistance load of 0.1 ohm. The battery is to discharge until a fire or explosion is obtained, or until it is completely discharged and the battery case temperature has returned to near ambient temperature.

9.2 Tests are to be conducted at room temperature and at 60 ±2°C (140 ±3.6°F). The batteries are to reach equilibrium at room temperature or 60 ±2°C (140 ±3.6°F), as applicable, before the terminals are connected.

9.3 A battery is to be tested individually unless the manufacturer indicates that it is intended for use in series or parallel. For series or parallel use, additional tests on five sets of batteries are to be conducted using the maximum number of batteries to be covered for each configuration.

9.4 When an overcurrent or thermal protective device that has been investigated for the purpose, actuates during the test, the test shall be repeated with the battery supply connected to the maximum load that does not cause the protective device to open. A protective device that has not been investigated for the purpose shall be short-circuited.

9.5 The samples shall not explode or catch fire. The temperature of the exterior cell or battery casing shall not exceed 150°C (302°F).

10 Abnormal Charging Test

10.1 Cells or batteries discharged to the manufacturer's rated capacity shall be used for this test.

10.2 Each test sample battery is to be subjected to a charging current of three times the current, I_c , specified by the manufacturer by connecting it in opposition to a dc-power supply. The specified charging current is to be obtained by connecting a resistor of the specified size and rating in series with the battery. The test time is to be calculated using the formula:

$$t_c = \frac{2.5 C}{3(I_c)}$$

In which:

t_c is the charging time in hours,

C is the capacity of battery in ampere-hours, and

I_c is the charging current, in amperes, specified by the manufacturer.

Note: The minimum test time shall be 48 hours. This does not require that the initial value I_c be maintained for 48 hours.

10.3 When an overcurrent or thermal protective device that has been investigated for the purpose, actuates during the test, the test shall be repeated with the battery supply connected to the maximum load that does not cause the protective device to open. A protective device that has not been investigated for the purpose shall be short-circuited.

10.4 The samples shall not explode or catch fire.

11 Abusive Overcharge Test

11.1 Sample batteries are to be subjected to a constant charging current at 10 times the C_5 amp rate. A thermocouple is to be attached to each test cell or battery. The test is to continue until the cell or battery explodes, vents, or the temperature of the outer casing reaches a steady state condition or returns to ambient.

11.2 During the tests, batteries supplied with overcurrent or thermal protective devices shall have the devices short circuited, unless they have been investigated for the purpose.

11.3 The samples shall not explode or catch fire.

12 Forced-Discharge Test

12.1 This test is intended for cells that are to be used in multicell applications, such as battery packs.

12.2 A completely discharged cell is to be force-discharged by connecting it in series with fresh cells of the same kind. The number of fresh cells to be connected in series with the discharged cell is to equal the maximum number less one of the cells to be covered for series use. Five cells are to be completely discharged, at room temperature.

12.3 Once the completely discharged cell is connected in series with the specified number of fresh cells the resultant battery pack is to be short circuited.

12.4 The positive and negative terminals of the sample are to be connected with a copper wire with a maximum resistance load of 0.1 ohm. The battery is to discharge until a fire or explosion is obtained, or until it is completely discharged and the battery case temperature has returned to near ambient temperature.

12.5 The samples shall not explode or catch fire.

13 Limited Power Source Test

Section 13 effective May 29, 1998

13.1 Determine the maximum power output capability, P_{MAX} , of the cell or battery, by varying the load impedance from open circuit to short circuit. Overcurrent or thermal protective devices shall be disabled or bypassed.

13.2 Three sample batteries are to be used for this test. The batteries shall be in the fully charged condition with overcurrent or thermal protective devices enabled (operational). The battery is to be loaded to the equivalent resistance load that produced P_{MAX} in 13.1 using a length of AWG 20 Nichrome wire. Two layers of cheesecloth shall be draped over the Nichrome wire in this test. The steady state circuit voltage and current at the battery terminals and the cheesecloth shall be monitored for 60 seconds.

13.3 When an overcurrent or thermal protective device that has been investigated for the purpose actuates during the test, the test shall be repeated with the battery supply connected to the maximum load that will not cause the protective device to open. A protective device that has not been investigated for the purpose shall be short circuited.

13.4 A cell or battery shall comply with the following requirements:

- a) The maximum output current after 60 seconds shall be less than or equal to 8.0 amp, and
- b) The power output shall be less than 5 times the open circuit voltage, measured at the end of a 60-second period, and
- c) The cheesecloth shall not ignite.

Cells and batteries that meet the requirements are eligible to include the Marking "LPS" to indicate that they are considered to be a limited power source. Cells and batteries that do not meet these requirements are restricted to applications where a limited power source is not required.

Exception: Batteries designed such that they cannot be externally shorted, (such as batteries equipped with retractable leads), need not meet these requirements.

MECHANICAL TESTS

14 Crush Test

14.1 A battery is to be crushed between two flat surfaces. The force for the crushing is to be applied by a hydraulic ram with a 1.25 inch (32 mm) diameter piston. The crushing is to be continued until a pressure reading of 2500 psig (17.2 MPa) is reached on the hydraulic ram, resulting in an applied force of 3000 pounds (13 kN). Once the maximum pressure has been obtained it is to be released.

14.2 A cylindrical or prismatic battery is to be crushed with its longitudinal axis parallel to the flat surfaces of the crushing apparatus. A prismatic battery is also to be rotated 90 degrees around its longitudinal axis so that both the wide and narrow sides will be subjected to the crushing force. Each sample battery is to be subjected to a crushing force in only one direction. Separate samples are to be used for each test.

14.3 A coin or button battery is to be crushed with the flat surface of the battery parallel with the flat surfaces of the crushing apparatus.

14.4 The samples shall not explode or catch fire.

15 Impact Test

15.1 A test sample battery is to be placed on a flat surface. A 5/8 inch (15.8 mm) diameter bar is to be placed across the center of the sample. A 20 ±1 pound (9.1 ±0.46 kg) weight is to be dropped from a height of 24 ±1 inch (610 ±25 mm) onto the sample. (See Figure 15.1.)

Figure 15.1
Impact test

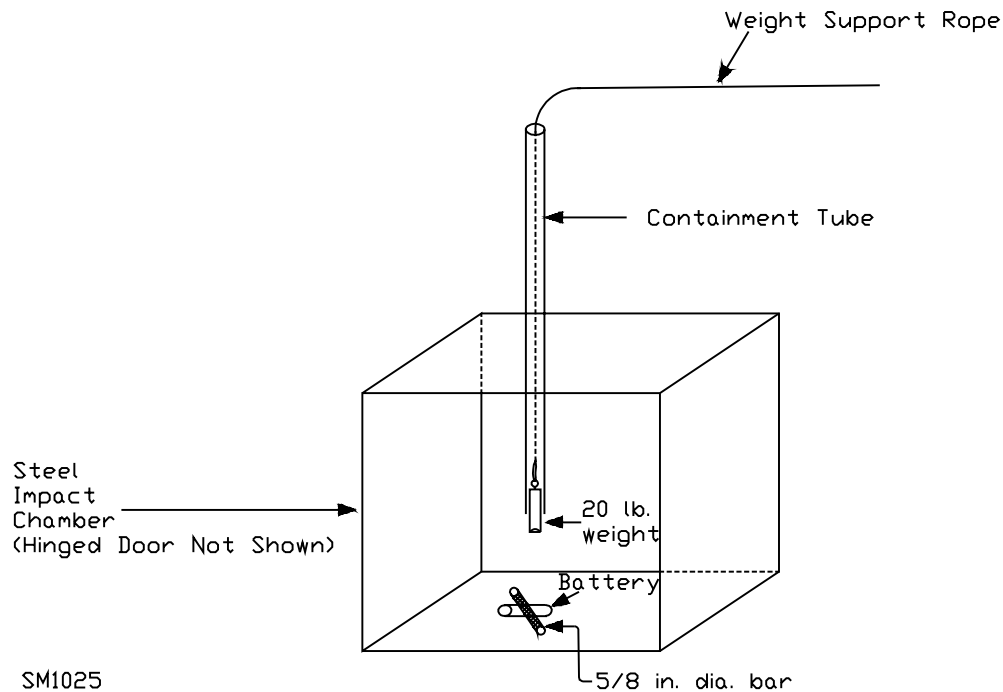

15.2 A cylindrical or prismatic battery is to be impacted with its longitudinal axis parallel to the flat surface and perpendicular to the longitudinal axis of a 5/8 inch (15.8 mm) diameter curved surface lying across the center of the test sample. A prismatic battery is also to be rotated 90 degrees around its longitudinal axis so that both the wide and narrow sides will be subjected to the impact. Each sample battery is to be subjected to only a single impact. Separate samples are to be used for each test.

15.3 A coin or button battery is to be impacted with the flat surface of the test sample parallel to the flat surface and the 5/8 inch (15.8 mm) diameter curved surface lying across its center.

15.4 The samples shall not explode or catch fire.

16 Shock Test

Section 16 effective May 29, 1998

16.1 The cell is to be secured to the testing machine by means of a rigid mount which supports all mounting surfaces of the cell. Each cell shall be subjected to a total of three shocks of equal magnitude. The shocks are to be applied in each of three mutually perpendicular directions unless it has only two axes of symmetry in which case only two directions shall be tested. Each shock is to be applied in a direction normal to the face of the cell. For each shock the cell is to be accelerated in such a manner that during the initial 3 milliseconds the minimum average acceleration is 75 g (where g is the local acceleration due to gravity). The peak acceleration shall be between 125 and 175 g. Cells shall be tested at a temperature of $20 \pm 5^{\circ}\text{C}$ ($68 \pm 9^{\circ}\text{F}$).

16.2 The samples shall not explode or catch fire. In addition, the sample shall not vent or leak as described in 5.2.

17 Vibration Test

Section 17 effective May 29, 1998

17.1 A battery is to be subjected to simple harmonic motion with an amplitude of 0.03 inch (0.8 mm) [0.06 inch (1.6 mm) total maximum excursion].

17.2 The frequency is to be varied at the rate of 1 hertz per minute between 10 and 55 hertz and return in not less than 90 nor more than 100 minutes. The battery is to be tested in three mutually perpendicular directions. For a battery that has only two axes of symmetry, the battery is to be tested perpendicular to each axis.

17.3 The samples shall not explode or catch fire. In addition, the sample shall not vent or leak as described in 5.2.

BATTERY ENCLOSURE TESTS

18 General

18.1 For batteries with plastic outer cases, the outer case of the battery shall be designed such that it is not capable of being opened using simple tools, such as a screwdriver. The case shall be ultrasonically welded, or sealed by equivalent means.

18.2 The outer case material of the battery shall be classed as V-2 or less flammable in accordance with the Standard for Polymeric Materials - Use in Electrical Equipment Evaluations, UL 746C.

Exception: Materials are not required to be classed as V-2 or less flammable when they comply with the enclosure flammability – 3/4 inch flame test described in the Standard for Polymeric Materials – Use in Electrical Equipment Evaluations, UL 746C.

18.2 revised February 27, 1998

18.3 Batteries with outer plastic enclosures shall be subjected to the tests described in Sections 19, 20, and 21.

19 250 lb. Crush Test

19.1 Three samples shall withstand for 1 minute a crushing force of 1112 N (250 pound force) applied to a 930 cm sq. (1 square foot) area in any direction at right angles to its major axis. The enclosure is to be tested between two 12.7 mm (1/2 inch) or thicker parallel flat maple blocks. The crushing force is to be applied gradually.

19.2 The samples shall not explode or catch fire. The sample shall not vent or leak as described in 5.2. In addition, the outer battery enclosure shall not crack to the extent that the cells or any protective devices are exposed.

20 Mold Stress Relief Test

20.1 Each of three samples are to be placed in a full-draft circulating-air oven maintained at a uniform temperature of 70°C (158°F). The samples are to remain in the oven for 7 hours.

20.2 After careful removal from the oven and return to room temperature, following the conditioning described in 20.1, the samples shall show no evidence of mechanical damage, such as cracking of the battery jacket or leakage of electrolyte.

20.3 The samples shall not explode or catch fire. The sample shall not vent or leak as described in 5.2. In addition, the outer battery enclosures shall not crack to the extent that the cells or any protective devices are exposed.

21 Drop Impact Test

21.1 Each of three samples is to be dropped from a height of 1 m (3.28 ft.) so it strikes a concrete surface in the position that is most likely to produce the adverse results in 21.2. Each sample is to be dropped three times.

21.2 The samples shall not explode or catch fire. In addition, the samples shall not vent or leak as described in 5.2, and the integrity of protective devices shall be maintained. In addition, the outer battery enclosure shall not crack to the extent that cells or any protective devices are exposed.

FIRE EXPOSURE TESTS

22 Test For Flaming Particles

22.1 Each test sample cell or battery is to be placed on a steel wire mesh screen having 20 openings per inch (25.4 mm) and a wire diameter of 0.017 inch (0.43 mm). The screen is to be mounted 1-1/2 inches (38.1 mm) above a burner. The fuel and air flow rates are to be set to provide a bright blue flame that causes the wire screen to glow a bright red. A panel of cheesecloth layers is to be positioned vertically 3 feet (0.91 m) from the center of the wire screen. See Figures 22.1 and 22.2. The panel of cheesecloth is to be 1 yard square (914 mm by 914 mm) and is to consist of four layers of cheesecloth material weighing 0.4 – 0.6 ounces per square yard (12 – 18 g/m²). The test sample is to be positioned so that sparks or flaming particles are ejected toward the center of the cheesecloth panel. In some cases, it shall be required to wire the test sample to the screen to hold it in place. The burner is then to be ignited and the battery is to be observed until it explodes, or until it is destroyed.

22.2 A cheesecloth panel shall not ignite when a cell or battery is subjected to the test described in 22.1.

Figure 22.1
Test apparatus for flaming particle test

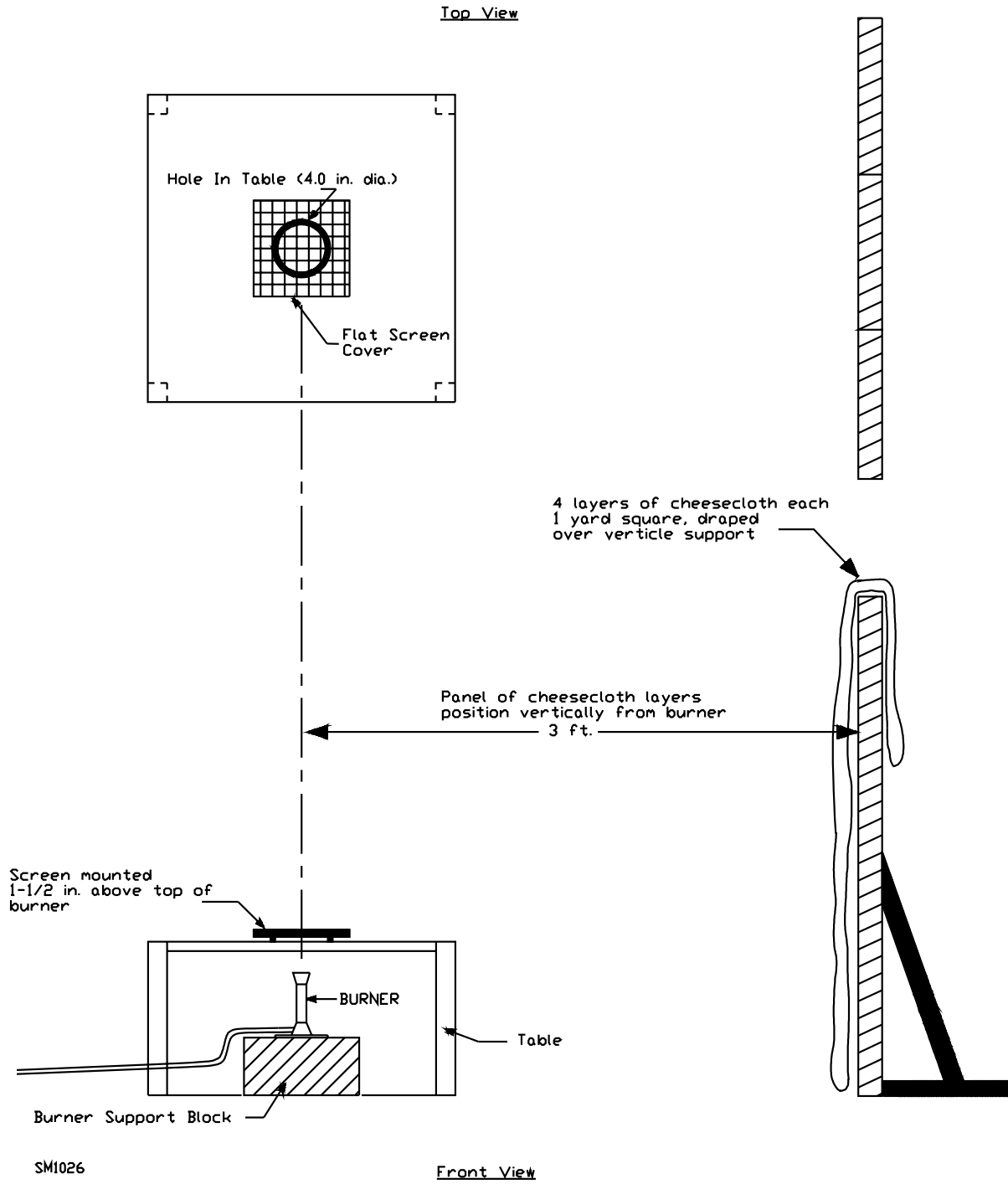
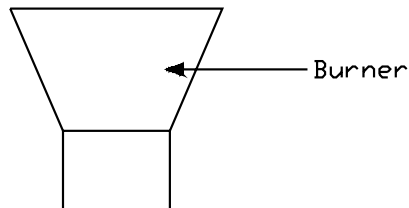
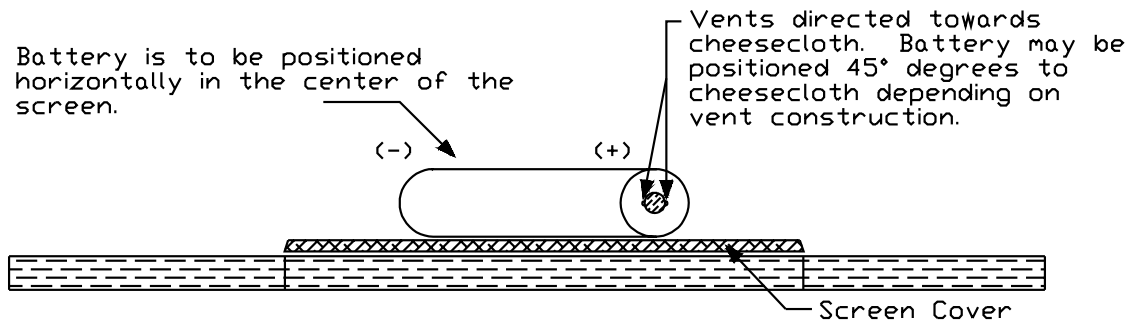

Figure 22.2
Battery orientation



SM1027

23 Projectile Test

23.1 Each test sample cell or battery is to be placed on a platform table having a 4-inch (102-mm) diameter hole in the center covered by a screen. The screen is to be constructed of steel wire mesh having 20 openings per inch (25.4 mm) and a wire diameter of 0.017 inch (0.43 mm). An eight-sided covered wire cage, 2 feet (610 mm) across and 1 foot (305 mm) high, made from metal screening is to be placed over the test sample. See Figure 23.1. The metal screening is to be constructed from 0.010-inch (0.25-mm) diameter metal wire with 16 – 18 wires per inch (25.4 mm) in each direction. The sample is to be placed on the screen covering the hole in the center of the table and is to be heated until it explodes, or until it is destroyed.

23.2 When subjected to the test described in 23.1 no part of an exploding cell or battery shall penetrate the wire screen such that some or all of the cell or battery protrudes through the screen.

No Text on This Page

Figure 23.1
Test apparatus for projectile test

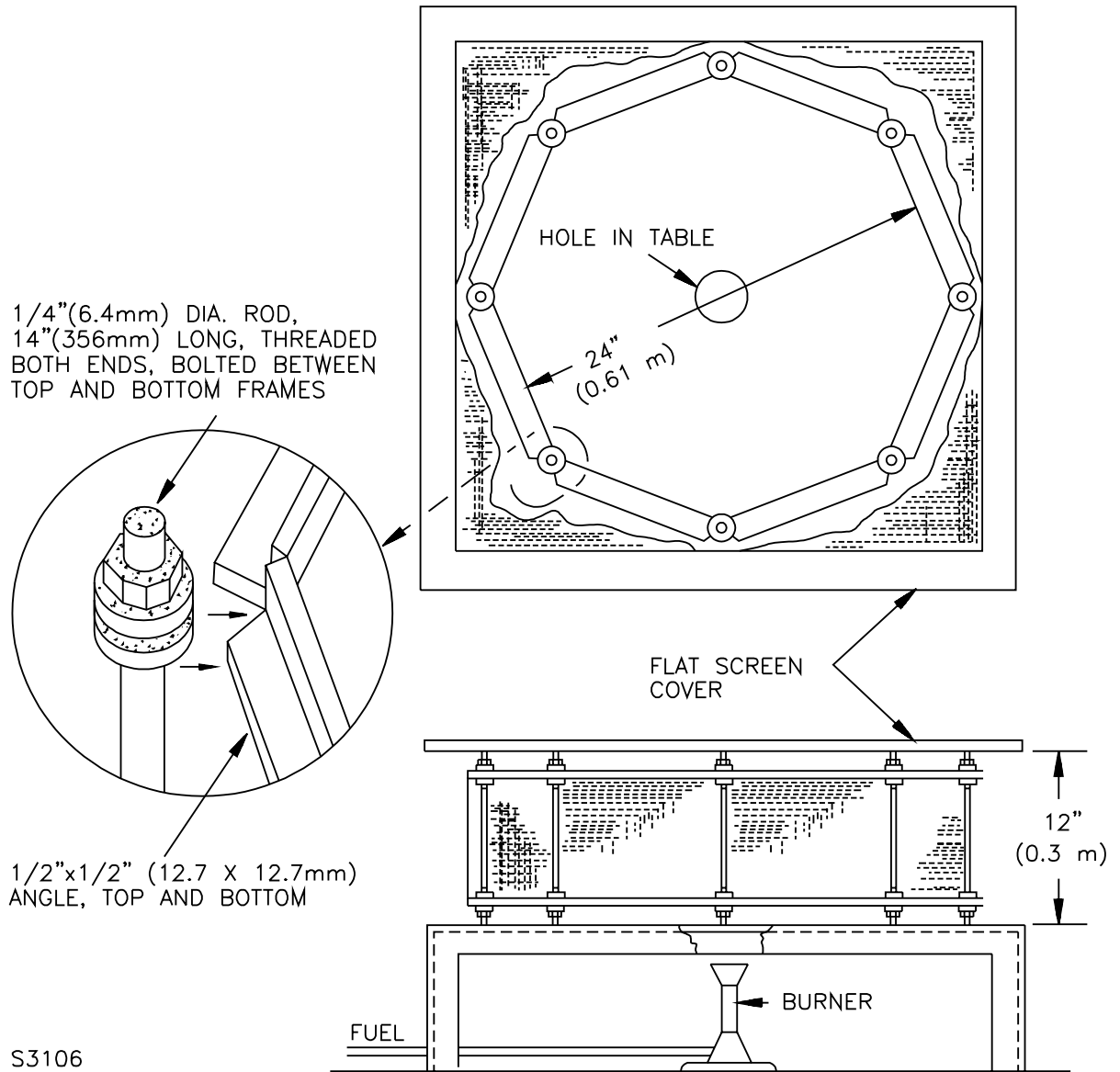

ENVIRONMENTAL TESTS

24 Heating Test

24.1 A battery is to be heated in a gravity convection or circulating air oven. The temperature of the oven is to be raised at a rate of $5 \pm 2^{\circ}\text{C}$ ($9 \pm 3.6^{\circ}\text{F}$) per minute to a temperature of $150 \pm 2^{\circ}\text{C}$ ($302 \pm 3.6^{\circ}\text{F}$). The oven is to remain for 10 minutes at $150 \pm 2^{\circ}\text{C}$ ($302 \pm 3.6^{\circ}\text{F}$) before the test is discontinued.

24.2 The samples shall not explode or catch fire.

25 Temperature Cycling Test

25.1 The batteries are to be placed in a test chamber and subjected to the following cycles:

- a) Raising the chamber-temperature to $70 \pm 3^{\circ}\text{C}$ ($158 \pm 5^{\circ}\text{F}$) within 30 minutes and maintaining this temperature for 4 hours.
- b) Reducing the chamber temperature to $20 \pm 3^{\circ}\text{C}$ ($68 \pm 5^{\circ}\text{F}$) within 30 minutes and maintaining this temperature for 2 hours.
- c) Reducing the chamber temperature to minus $40 \pm 3^{\circ}\text{C}$ (minus $40 \pm 5^{\circ}\text{F}$) within 30 minutes and maintaining this temperature for 4 hours.
- d) Raising the chamber temperature to $20 \pm 3^{\circ}\text{C}$ ($68 \pm 5^{\circ}\text{F}$) within 30 minutes.
- e) Repeating the sequence for a further 9 cycles.
- f) After the 10th cycle, storing the batteries for 7 days prior to examination.

25.2 The samples shall not explode or catch fire. In addition, the samples shall not vent or leak as described in 5.2.

MARKING

26 General

26.1 A battery shall be marked with the manufacturer's name, trade name, or trademark and model designation.

26.2 When a manufacturer produces the battery at more than one factory, each battery shall have a distinctive marking to identify it as the product of a particular factory.

26.3 A battery or the smallest unit package or instructions provided with each battery shall include the following statements or equivalent:

- a) An attention word, such as "Caution," "Warning," or "Danger."
- b) A brief description of possible hazards associated with mishandling of the battery, such as burn hazard, fire hazard, explosion hazard.
- c) A list of actions to take to avoid possible hazards, such as do not crush, disassemble, dispose of in fire, or similar actions.

26.4 The manufacturer's specified charging instructions shall be included.

26.5 A cell or battery that is less than 1.25 inches (32 mm) in diameter by 0.15 in. (3.8 mm) thick shall include the following marking or equivalent:

"Caution never put batteries in mouth. If swallowed, contact your physician or local poison control center."

26.6 Batteries which meet the requirements of the Limited Power Source Test, Paragraph 13.4, may include the Marking "LPS."

No Text on This Page

Subjects 1642, 2054

333 Pfingsten Road
Northbrook, IL 60062
April 29, 1999

**TO: Industry Representatives on the Industry Advisory Conference of UL for Lithium Batteries
Casualty Council of Underwriters Laboratories Inc.
Electrical Council of Underwriters Laboratories Inc.
Fire Council of Underwriters Laboratories Inc.
Subscribers to UL's Standards Service for Lithium Batteries
Subscribers to UL's Standards Service for Household Commercial Batteries
Subscribers to UL's Listing Service for Household Commercial Batteries
Subscribers to UL's Recognition Service for Sealed Nickel Batteries, and Lithium Batteries**

SUBJECT: Performance Testing of Batteries

UL announces a program to include additional performance testing as part of the Listing and Recognition programs for Household and Commercial, Sealed Nickel, and Lithium Batteries. The performance testing will include determination of battery capacity at various temperatures, capacity retention following long term storage, cycle life, and determination of internal resistance. This testing can be conducted in accordance with the proposed ANSI and IEC standards for portable primary and rechargeable batteries and can be done during a submittal for battery Listing or Recognition or conducted independently.

UL will also participate with industry in any future development of ANSI or IEC performance test procedures and requirements.

This bulletin should be kept with your copy of the standard.

Questions regarding interpretation of requirements should be directed to the responsible UL Staff. Please see Appendix A of this bulletin regarding designated responsibility for the subject product categories. Please contact Joseph Allen or John Hawley for information regarding battery performance testing.

UNDERWRITERS LABORATORIES INC.

JEFF PRUSKO (Ext. 43416)
Project Engineer
Standards Department

REVIEWED BY:

JOSEPH P. ALLEN (Ext. 43103)
Engineering Group Leader
Engineering Services 3016ENBK

REVIEWED BY:

JOHN HAWLEY (Ext. 42077)
Managing Engineer
Engineering Services 3016XNBK

AM

1642ann.sgm

APPENDIX A

DESIGNATED RESPONSIBILITY FOR UL PRODUCT CATEGORIES

BBCV2, LITHIUM BATTERIES – COMPONENT
 BBET2, NICKEL, SEALED BATTERIES – COMPONENT
 BBFS, HOUSEHOLD AND COMMERCIAL BATTERIES

The individuals shown in the following tables are involved with the investigation of products covered under the subject categories. The Primary Designated Engineer (shown in UPPERCASE letters) coordinates the establishment and uniform interpretation of UL requirements applicable to the product categories. The Designated Engineers (shown in lowercase letters) work with the Primary Designated Engineer to interpret requirements and maintain standards.

Should you have questions regarding the interpretation of the requirements proposed in this bulletin or any adopted requirements that affect your product, you are encouraged to contact the individual at the office to which you normally submit your products.

The Industry Advisory Conference (IAC) Chairman for the subject categories is John Hawley at UL's Northbrook office. The IAC Chairman oversees the significant interpretations made by the Primary Designated Engineer and arbitrates any differences regarding interpretation of UL requirements.

CCN	Office/Subsidiary	Responsible Engineer	Extension
BBCV2	Northbrook	JOSEPH ALLEN	43103
	RTP	Stephen Derynck	11663
	Santa Clara	Andrea Cote	32940

CCN	Office/Subsidiary	Responsible Engineer	Extension
BBET2	Camas	Daniel Deatherage	55682
	Northbrook	JOSEPH ALLEN	43103
	Santa Clara	Andrea Cote	32940

CCN	Office/Subsidiary	Responsible Engineer	Extension
BBFS	Northbrook	JOSEPH ALLEN	43103
	Taiwan	Cannon Sun	70323

No Text on This Page