

**DUAL OP AMP AND VOLTAGE REFERENCE****AP4300****General Description**

The AP4300 is a monolithic IC specifically designed to regulate the output current and voltage levels of switching battery chargers and power supplies.

The device contains two operational amplifiers and a precision shunt regulator. Op Amp 1 is designed for voltage control, whose non-inverting input internally connects to the output of the shunt regulator. Op Amp 2 is for current control with both inputs uncommitted. The IC offers the power converter designer a control solution that features increased precision with a corresponding reduction in system complexity and cost.

The AP4300 is available in standard packages of DIP-8 and SOIC-8.

Features**Op Amp**

- Input Offset Voltage: 0.5mV
- Supply Current: 250 μ A per Op Amp at 5.0V Supply Voltage
- Unity Gain Bandwidth: 1MHz
- Output Voltage Swing: 0 to ($V_{CC} - 1.5$) V
- Power Supply Range: 3 to 18V

Voltage Reference

- Fixed Output Voltage Reference: 2.5V, 2.6V
- Voltage Tolerance: 0.5%, 1%
- Sink Current Capability from 0.1 to 80mA

Applications

- Battery Charger
- Switching Power Supply

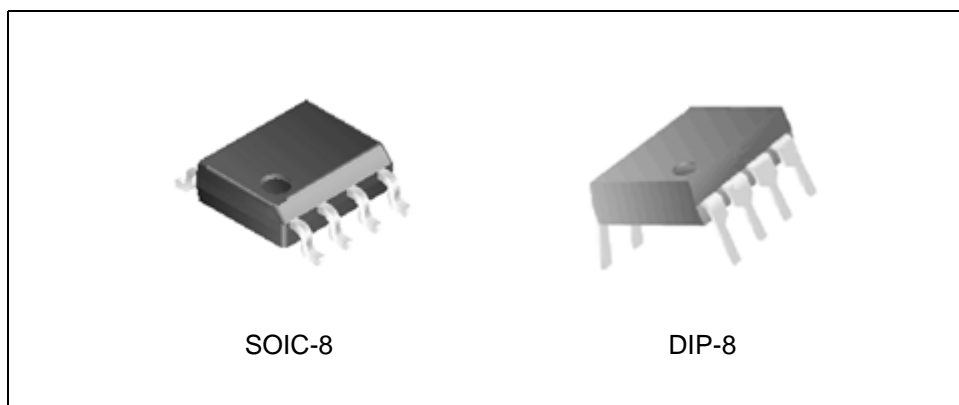

Figure 1. Package Types of AP4300



DUAL OP AMP AND VOLTAGE REFERENCE

AP4300

Pin Configuration

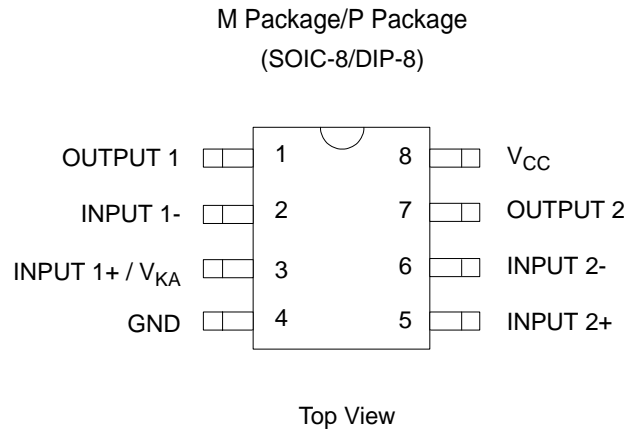

Figure 2. Pin Configuration of AP4300

Functional Block Diagram

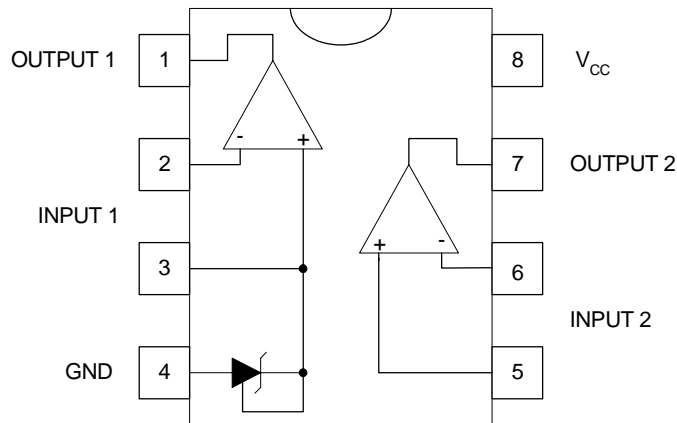

Figure 3. Functional Block Diagram of AP4300



DUAL OP AMP AND VOLTAGE REFERENCE

AP4300

Functional Block Diagram (Continued)

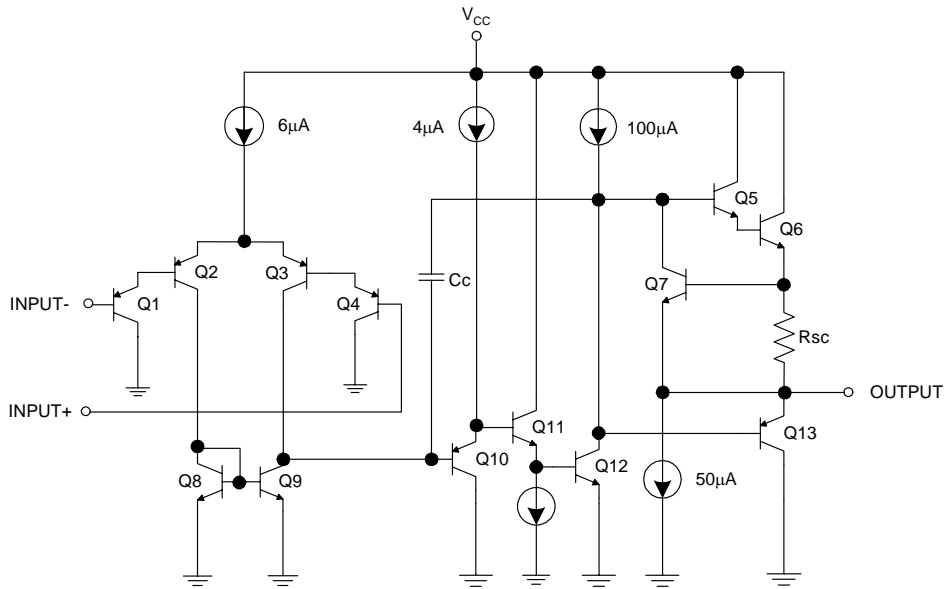

Figure 4. Op Amp Functional Block Diagram (Each Amplifier)

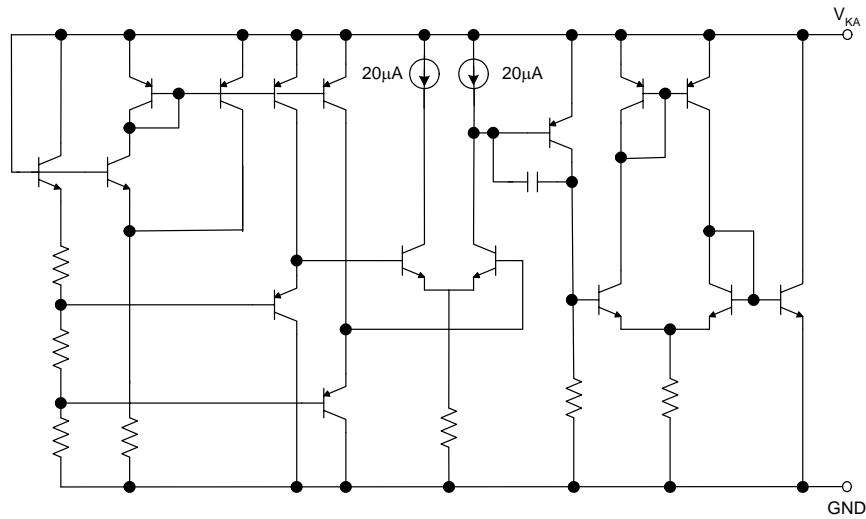

Figure 5. Voltage Reference Functional Block Diagram



DUAL OP AMP AND VOLTAGE REFERENCE

AP4300

Ordering Information

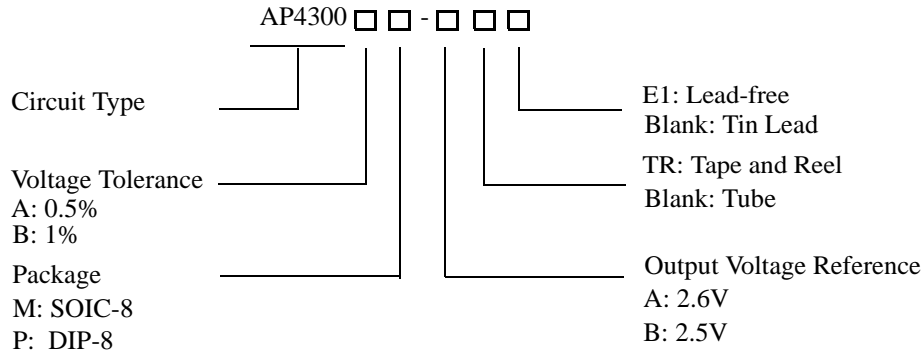

Package	Reference Voltage	Voltage Tolerance	Temperature Range	Part Number		Marking ID		Packing Type
				Tin Lead	Lead Free	Tin Lead	Lead Free	
DIP-8	2.6V	0.5%	-40 to 105°C	AP4300AP-A	AP4300AP-AE1	AP4300AP-A	AP4300AP-AE1	Tube
		1%		AP4300BP-A	AP4300BP-AE1	AP4300BP-A	AP4300BP-AE1	
	2.5V	0.5%		AP4300AP-B	AP4300AP-BE1	AP4300AP-B	AP4300AP-BE1	
		1%		AP4300BP-B	AP4300BP-BE1	AP4300BP-B	AP4300BP-BE1	
SOIC-8	2.6V	0.5%	-40 to 105°C	AP4300AM-A	AP4300AM-AE1	AP4300AM-A	AP4300AM-AE1	Tube
		1%		AP4300AM-ATR	AP4300AM-ATRE1	AP4300AM-A	AP4300AM-AE1	Tape & Reel
				AP4300BM-A	AP4300BM-AE1	AP4300BM-A	AP4300BM-AE1	Tube
		AP4300BM-ATR		AP4300BM-ATRE1	AP4300BM-A	AP4300BM-AE1	Tape & Reel	
	2.5V	0.5%		AP4300AM-B	AP4300AM-BE1	AP4300AM-B	AP4300AM-BE1	Tube
				AP4300AM-BTR	AP4300AM-BTRE1	AP4300AM-B	AP4300AM-BE1	Tape & Reel
		1%		AP4300BM-B	AP4300BM-BE1	AP4300BM-B	AP4300BM-BE1	Tube
				AP4300BM-BTR	AP4300BM-BTRE1	AP4300BM-B	AP4300BM-BE1	Tape & Reel

BCD Semiconductor's Pb-free products, as designated with "E1" suffix in the part number, are RoHS compliant.

**DUAL OP AMP AND VOLTAGE REFERENCE****AP4300****Absolute Maximum Ratings (Note 1)**

Parameter	Symbol	Value	Unit	
Power Supply Voltage (V_{CC} to GND)	V_{CC}	20	V	
Op Amp 1 and 2 Input Voltage Range (Pins 2, 5, 6)	V_{IN}	- 0.3 to $V_{CC} + 0.3$	V	
Op Amp 2 Input Differential Voltage (Pins 5, 6)	V_{ID}	20	V	
Voltage Reference Cathode Current (Pin 3)	I_K	100	mA	
Power Dissipation	P_D	DIP-8	800	mW
		SOIC-8	500	
Storage Temperature Range	T_{STG}	-65 to 150	°C	
ESD Protection Voltage (Machine Model)		> 200	V	

Note 1: Stresses greater than those listed under "Absolute Maximum Ratings" may cause permanent damage to the device. These are stress ratings only, and functional operation of the device at these or any other conditions beyond those indicated under "Recommended Operating Conditions" is not implied. Exposure to "Absolute Maximum Ratings" for extended periods may affect device reliability.

Recommended Operating Conditions

Parameter	Min	Max	Unit
Supply Voltage	3	18	V
Ambient Temperature	-40	105	°C



DUAL OP AMP AND VOLTAGE REFERENCE

AP4300

Electrical Characteristics

Operating Conditions: $V_{CC} = +5V$, $T_A = 25^\circ C$ unless otherwise specified.

Parameter	Conditions	Min	Typ	Max	Unit	
Total Supply Current, Excluding Current in Voltage Reference	$V_{CC} = 5V$, no load, $-40^\circ C \leq T_A \leq 105^\circ C$		0.5	0.8	mA	
	$V_{CC} = 18V$, no load, $-40^\circ C \leq T_A \leq 105^\circ C$		0.6	1.2		
Voltage Reference Section						
Reference Voltage for AP4300-A	$I_K = 10mA$, $T_A = 25^\circ C$	0.5% tolerance	2.587	2.600	2.613	V
		1% tolerance	2.574		2.626	
Reference Voltage for AP4300-B	$I_K = 10mA$, $T_A = 25^\circ C$	0.5% tolerance	2.487	2.500	2.513	V
		1% tolerance	2.475		2.525	
Reference Voltage Deviation over Full Temperature Range	$I_K = 10mA$, $T_A = -40$ to $105^\circ C$		5	24	mV	
Minimum Cathode Current for Regulation			0.1	1	mA	
Dynamic Impedance	$I_K = 1.0$ to $80mA$, $f < 1kHz$		0.2	0.5	Ω	
Op Amp 1 Section ($V_{CC} = 5V$, $V_O = 1.4V$, $T_A = 25^\circ C$, unless otherwise noted)						
Input Offset Voltage	$T_A = 25^\circ C$		0.5	3	mV	
		$T_A = -40$ to $105^\circ C$		5		
Input Offset Voltage Temperature Drift	$T_A = -40$ to $105^\circ C$			7	$\mu V/^\circ C$	
Input Bias Current (Inverting Input Only)	$T_A = 25^\circ C$		20	150	nA	
Large Signal Voltage Gain	$V_{CC} = 15V$, $R_L = 2K\Omega$, $V_O = 1.4$ to $11.4V$	85	100		dB	
Power Supply Rejection Ratio	$V_{CC} = 5$ to $18V$	70	90		dB	
Output Current	Source	$V_{CC} = 15V$, $V_{ID} = 1V$, $V_O = 2V$	20	40	mA	
	Sink	$V_{CC} = 15V$, $V_{ID} = -1V$, $V_O = 2V$	10	20	mA	
Output Voltage Swing (High)	$V_{CC} = 18V$, $R_L = 10K\Omega$, $V_{ID} = 1V$	16	16.5		V	
Output Voltage Swing (Low)	$V_{CC} = 18V$, $R_L = 10K\Omega$, $V_{ID} = -1V$		17	100	mV	
Slew Rate	$V_{CC} = 18V$, $R_L = 2k\Omega$, $A_V = 1$, $V_{IN} = 0.5$ to $2V$, $C_L = 100pF$	0.2	0.5		$V/\mu s$	
Gain Bandwidth Product	$V_{CC} = 18V$, $R_L = 2k\Omega$, $C_L = 100pF$, $V_{IN} = 10mV$, $f = 100kHz$	0.7	1		MHz	



DUAL OP AMP AND VOLTAGE REFERENCE

AP4300

Electrical Characteristics (Continued)

Operating Conditions: $V_{CC} = +5V$, $T_A = 25^\circ C$ unless otherwise specified.

Parameter	Conditions	Min	Typ	Max	Unit
Op Amp 2 Section ($V_{CC} = 5V$, $V_O = 1.4V$, $T_A = 25^\circ C$, unless otherwise noted)					
Input Offset Voltage	$T_A = 25^\circ C$		0.5	3	mV
	$T_A = -40$ to $105^\circ C$			5	
Input Offset Voltage Temperature Drift	$T_A = -40$ to $105^\circ C$			7	$\mu V/^\circ C$
Input Offset Current	$T_A = 25^\circ C$		2	30	nA
Input Bias Current	$T_A = 25^\circ C$		20	150	nA
Input Voltage Range	$V_{CC} = 0$ to $18V$	0		$V_{CC} - 1.5$	V
Common Mode Rejection Ratio	$T_A = 25^\circ C$, $V_{CM} = 0$ to $3.5V$	70	85		dB
Large Signal Voltage Gain	$V_{CC} = 15V$, $R_L = 2k\Omega$, $V_O = 1.4$ to $11.4V$	85	100		dB
Power Supply Rejection Ratio	$V_{CC} = 5$ to $18V$	70	90		dB
Output Current	Source	$V_{CC} = 15V$, $V_{ID} = 1V$, $V_O = 2V$	20	40	mA
	Sink	$V_{CC} = 15V$, $V_{ID} = -1V$, $V_O = 2V$	10	20	mA
Output Voltage Swing (High)	$V_{CC} = 18$, $R_L = 10k\Omega$, $V_{ID} = 1V$	16	16.5		V
Output Voltage SWing (Low)	$V_{CC} = 18$, $R_L = 10k\Omega$, $V_{ID} = -1V$		17	100	mV
Slew Rate	$V_{CC} = 18V$, $R_L = 2k\Omega$, $A_V = 1$, $V_{IN} = 0.5$ to $2V$, $C_L = 100pF$	0.2	0.5		$V/\mu s$
Gain Bandwidth Product	$V_{CC} = 18V$, $R_L = 2k\Omega$, $C_L = 100pF$, $V_{IN} = 10mV$, $f=100kHz$	0.7	1		MHz



DUAL OP AMP AND VOLTAGE REFERENCE

AP4300

Typical Performance Characteristics

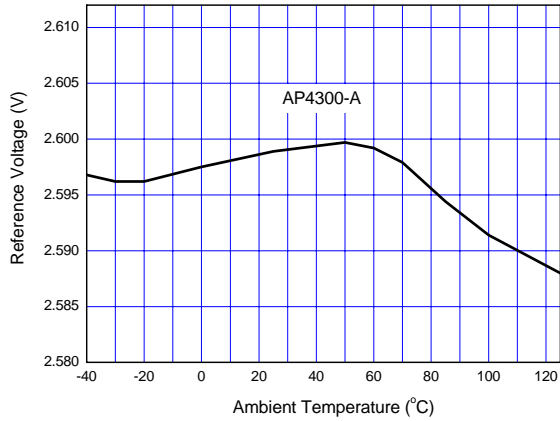

Figure 6. Reference Voltage vs. Ambient Temperature

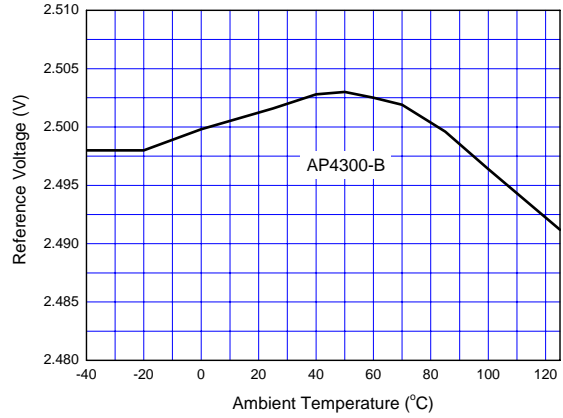

Figure 7. Reference Voltage vs. Ambient Temperature

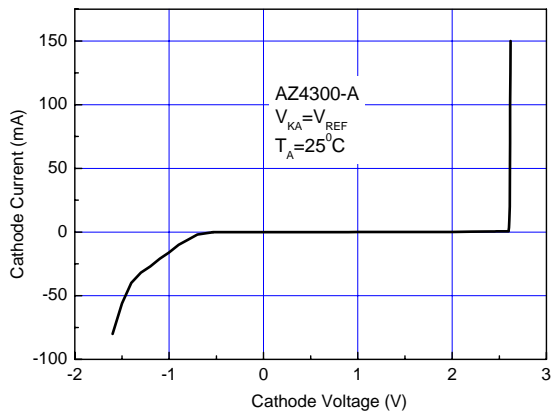

Figure 8. Cathode Current vs. Cathode Voltage

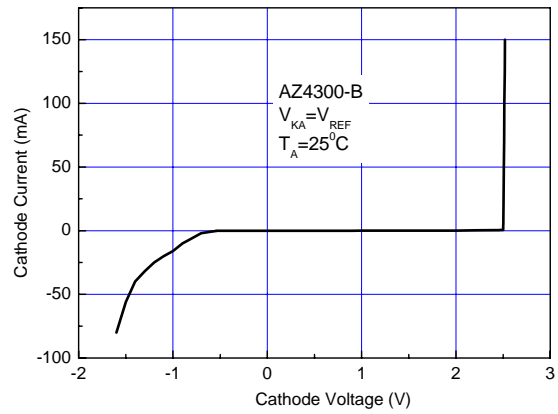

Figure 9. Cathode Current vs. Cathode Voltage

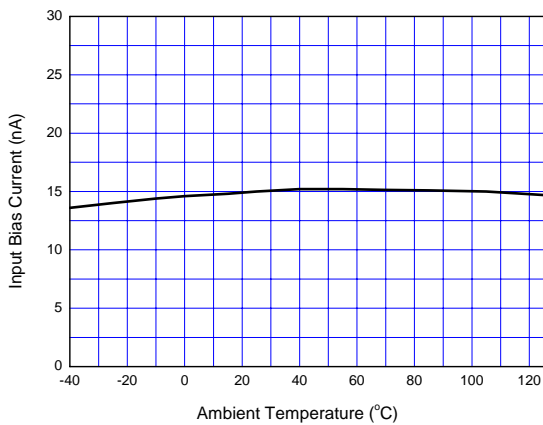

Figure 10. Input Bias Current vs. Ambient Temperature

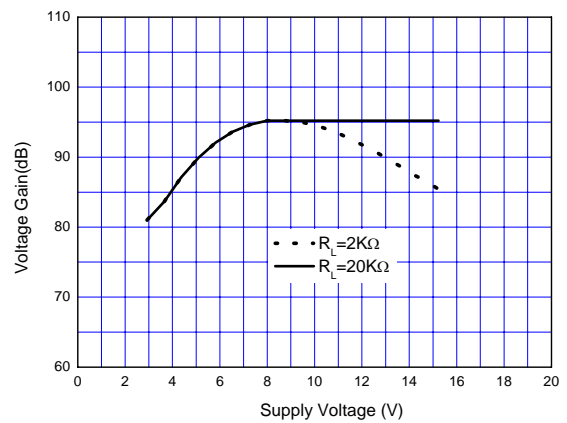

Figure 11. Operational Amplifier Voltage Gain



DUAL OP AMP AND VOLTAGE REFERENCE

AP4300

Typical Application

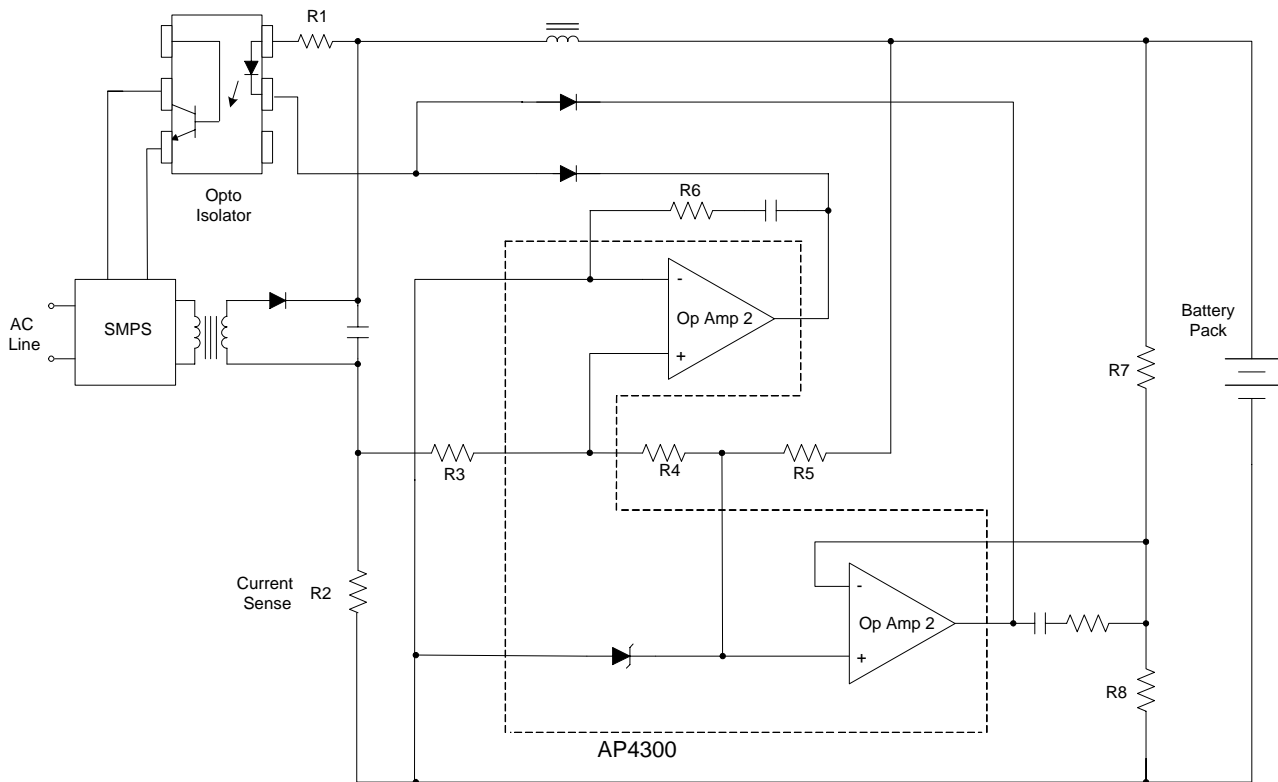

Figure 12. Application of AP4300 in a Constant Current and Constant Voltage Charger



DUAL OP AMP AND VOLTAGE REFERENCE

AP4300

Mechanical Dimensions

DIP-8

Unit: mm(inch)

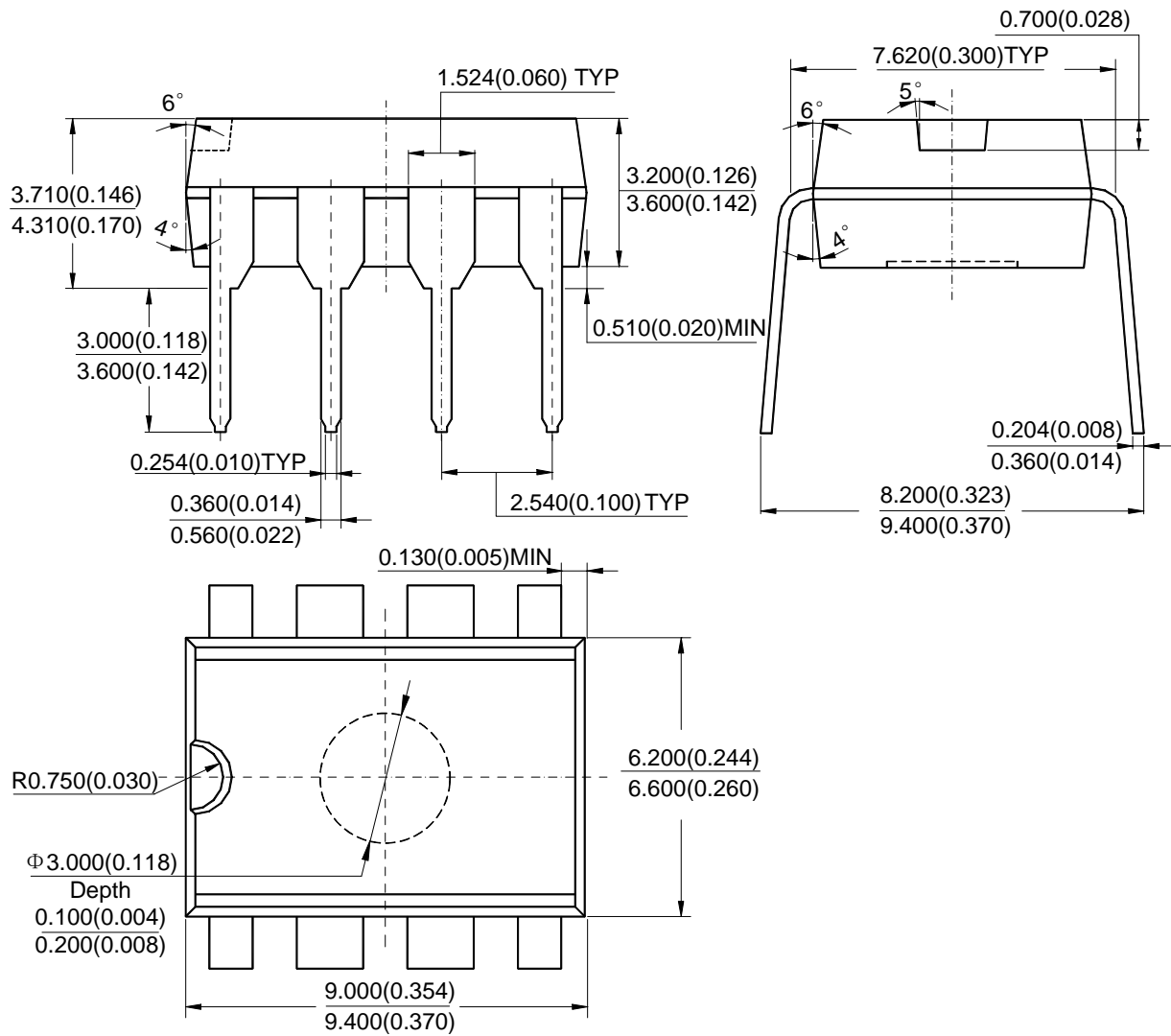



DUAL OP AMP AND VOLTAGE REFERENCE

AP4300

Mechanical Dimensions (Continued)

SOIC-8

Unit: mm(inch)

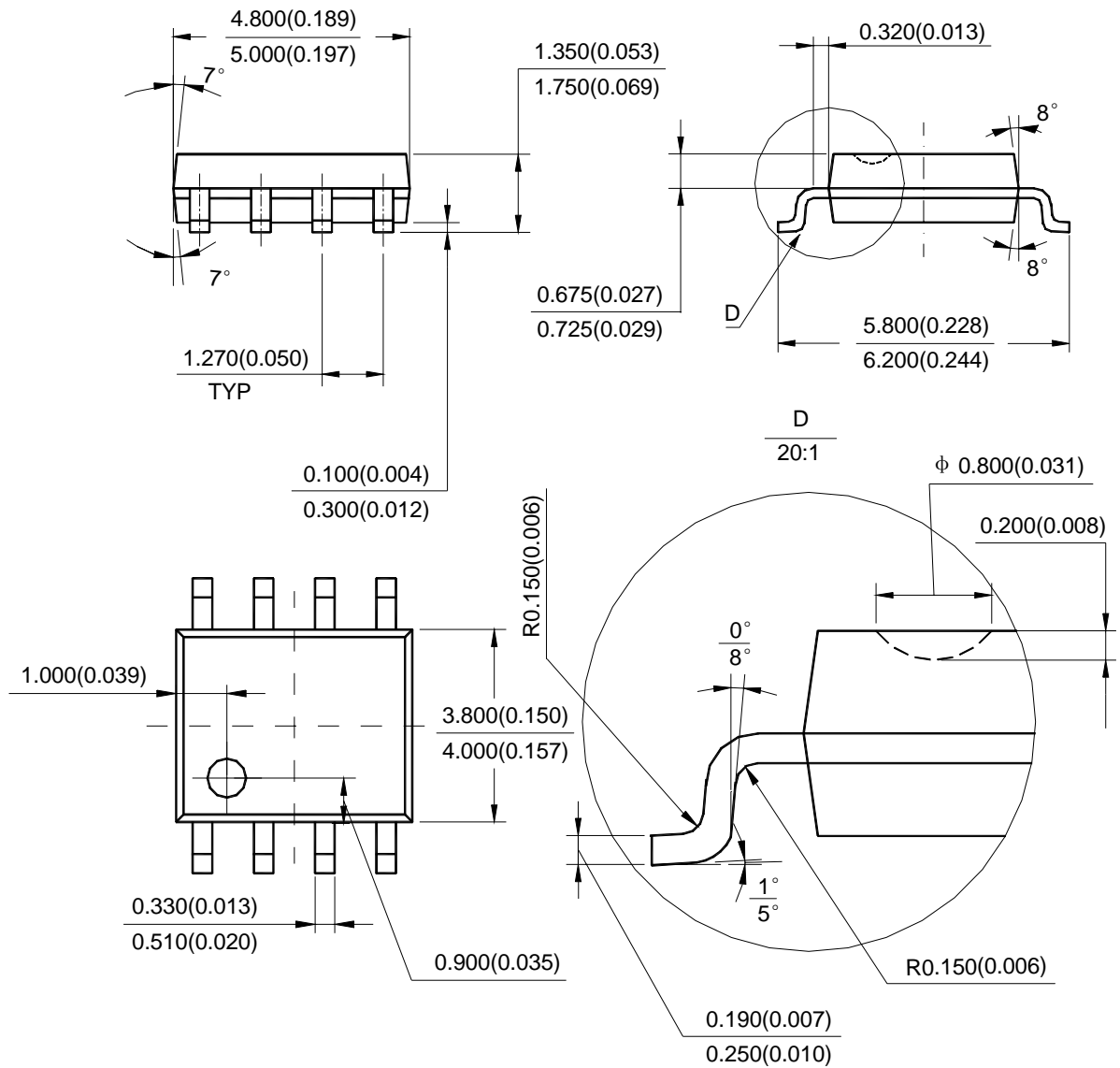



BCD Semiconductor Manufacturing Limited

<http://www.bcdsemi.com>

BCD Semiconductor Corporation

3170 De La Cruz Blvd, Suite # 105 Santa Clara, CA 95054-2411, U.S.A

Tel: +1-408-988 6388, Fax: +1-408-988 6386

Shanghai SIM-BCD Semiconductor Manufacturing Co., Ltd.

800 Yi Shan Road, Shanghai 200233, PRC

Tel: +86-21-6485-1491, Fax: +86-21-5450-0008

Advanced Analog Circuits (Shanghai) Corporation

8F, B Zone, 900 Yi Shan Road, Shanghai 200233, PRC

Tel: +86-21-6495 9539, Fax: +86-21-6485 9673

BCD Semiconductor (Taiwan) Company Limited

Room 2210, 22nd Fl, 333, Keelung Road, Sec. 1, TaiPei (110), Taiwan

Tel: +886-2-2758 6828, Fax: +886-2-2758 6892

IMPORTANT NOTICE

BCD Semiconductor Manufacturing Limited reserves the right to make changes without further notice to any products or specifications herein. BCD Semiconductor Manufacturing Limited does not assume any responsibility for use of any its products for any particular purpose, nor does BCD Semiconductor Manufacturing Limited assume any liability arising out of the application or use of any its products or circuits. BCD Semiconductor Manufacturing Limited does not convey any license under its patent rights or other rights nor the rights of others.

This datasheet has been downloaded from:

www.EEworld.com.cn

Free Download

Daily Updated Database

100% Free Datasheet Search Site

100% Free IC Replacement Search Site

Convenient Electronic Dictionary

Fast Search System

www.EEworld.com.cn