

The Best MOSFET for Li-ion Battery Protection

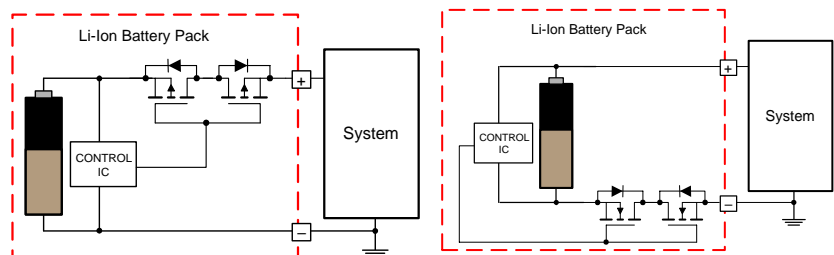

董沛@ Fairtek Int'l Ltd.

May.10th 2006



Battery Isolation

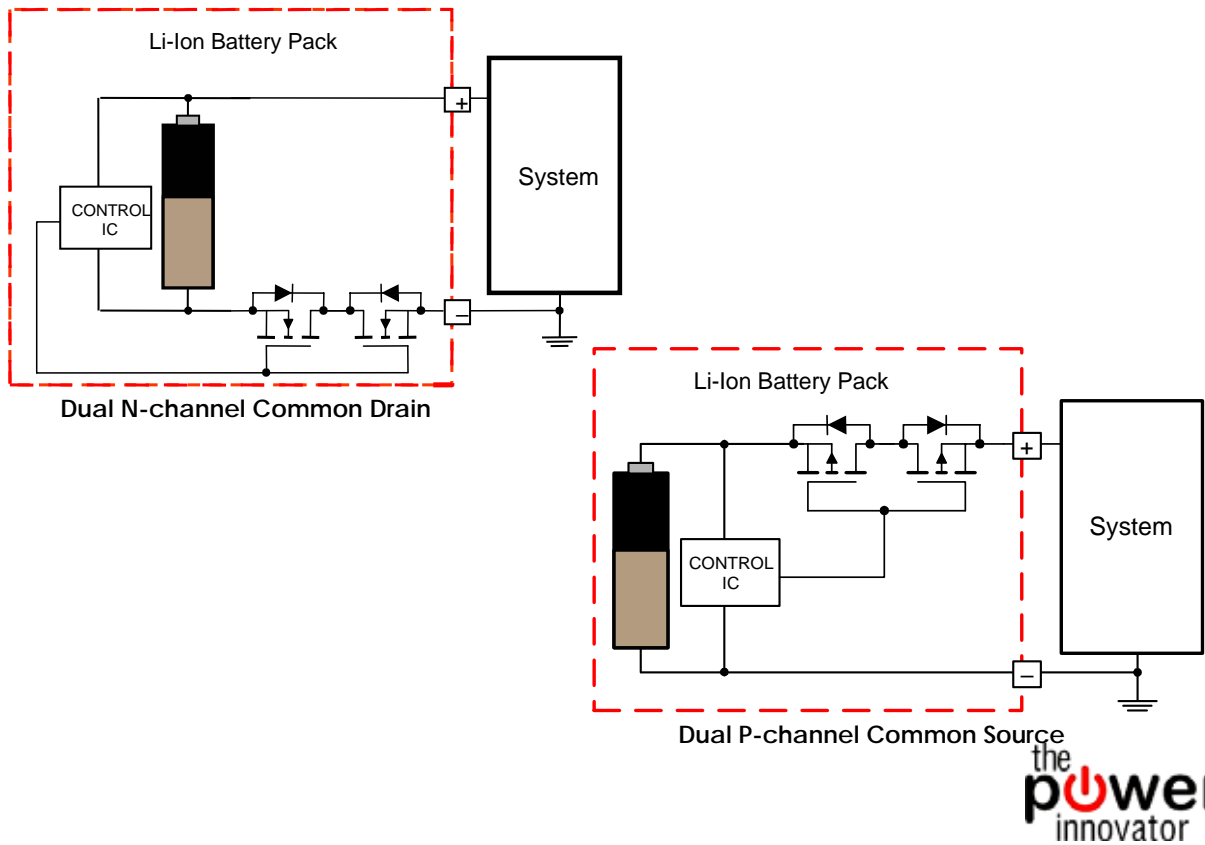

the power innovator

Common-Drain MOSFET For Li-Ion Battery

- CEJ8218 (*Pin-Pin compare ECH8601)

- The MOSFET

- $V_{DSS} = 20$ Volt
- $R_{DS} = 23$ m Ω @ 4.5 V_{GS}
- $R_{DS} = 34$ m Ω @ 2.5 V_{GS}

- The Package

- J-Lead 8 (*Same package with ECH8601)
- Common-Drain
- Isolated drain and source pins
- Lead-free package
- ESD protection

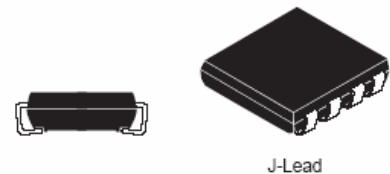
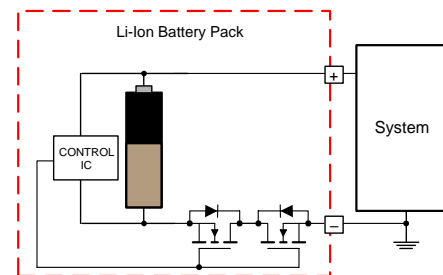

J-Lead

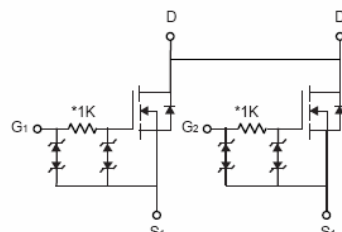

*Typical value by design

Released! Samples with ESD available NOW

the power innovator

Common-Drain MOSFET For Li-Ion Battery

- CEG8208

- The MOSFET

- $V_{DSS} = 20$ Volt
- $R_{DS} = 22\text{ m}\Omega @ 4.5\text{ V}_{GS}$
- $R_{DS} = 32\text{ m}\Omega @ 2.5\text{ V}_{GS}$

- The Package

- TSSOP-8
- Common-Drain
- Isolated drain and source pins
- Lead-free package
- ESD protection

Released! Samples with ESD available NOW

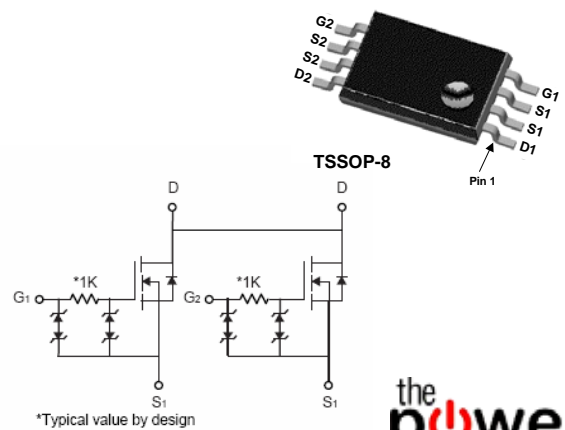
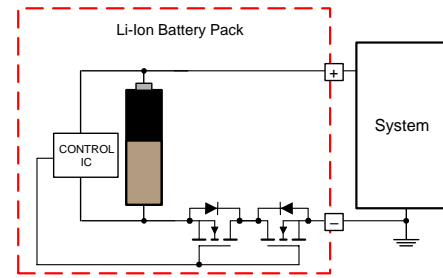

the power innovator

Common-Drain MOSFET For Li-Ion Battery

- CEG8205A

- The MOSFET

- $V_{DSS} = 20$ Volt
- $R_{DS} = 27.5\text{ m}\Omega @ 4.5\text{ V}_{GS}$
- $R_{DS} = 35.5\text{ m}\Omega @ 2.5\text{ V}_{GS}$

- The Package

- TSSOP-8
- Common-Drain
- Isolated drain and source pins
- Lead-free product is acquired

Part shipping in high volume!

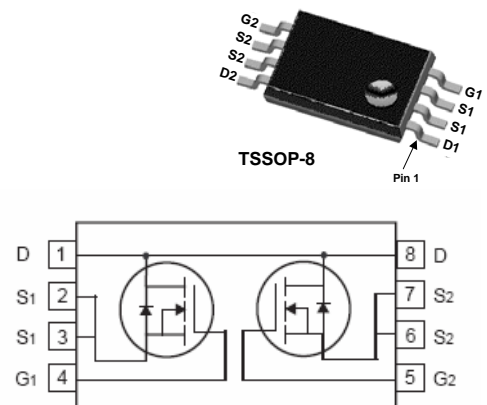
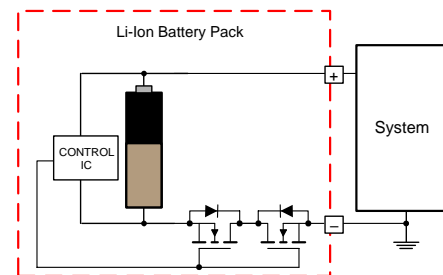

the power innovator

Common-Drain MOSFET For Li-Ion Battery

- CEG8205

- The MOSFET

- $V_{DSS} = 20$ Volt
- $R_{DS} = 30$ m Ω @ 4.5 V_{GS}
- $R_{DS} = 40$ m Ω @ 2.5 V_{GS}

- The Package

- TSSOP-8
- Common-Drain
- Isolated drain and source pins
- Lead-free product is acquired

Part shipping in high volume!

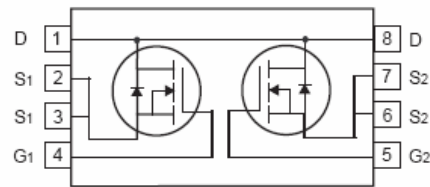
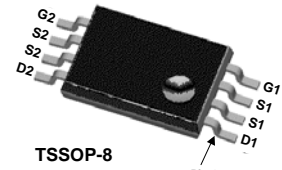
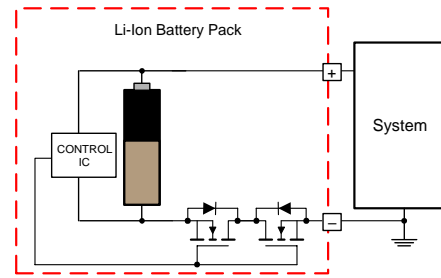

the power innovator

Dual N-Ch MOSFET For Li-Ion Battery

- CEM9926A

- The MOSFET

- $V_{DSS} = 20$ Volt
- $R_{DS} = 30$ m Ω @ 4.5 V_{GS}
- $R_{DS} = 40$ m Ω @ 2.5 V_{GS}

- The Package

- SOIC-8
- Isolated drain and source pins
- Lead-free product is acquired

Part shipping in high volume!

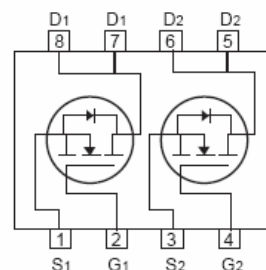
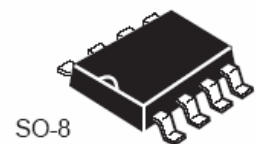
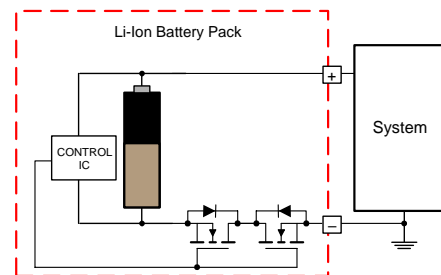

the power innovator

ESD Gate Protection

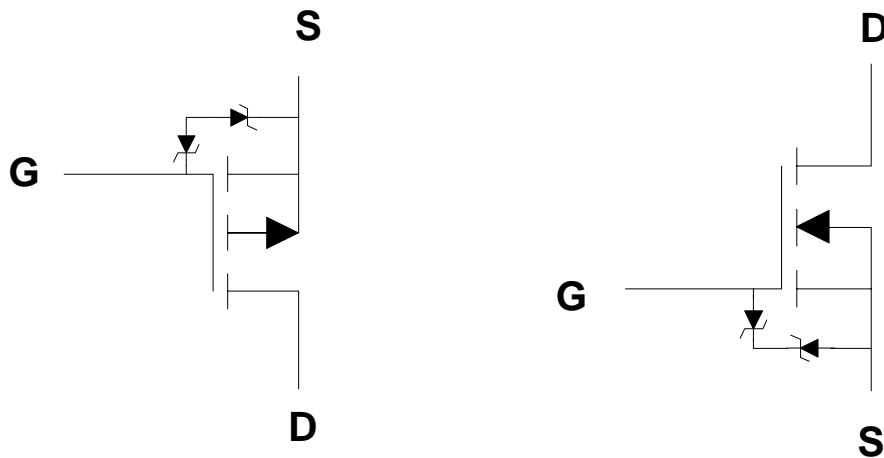

- 2000 V ESD Gate protection process for TSSOP & J-Lead package
- CEG8208 /CEJ8218 released already.....



Packaging Roadmap

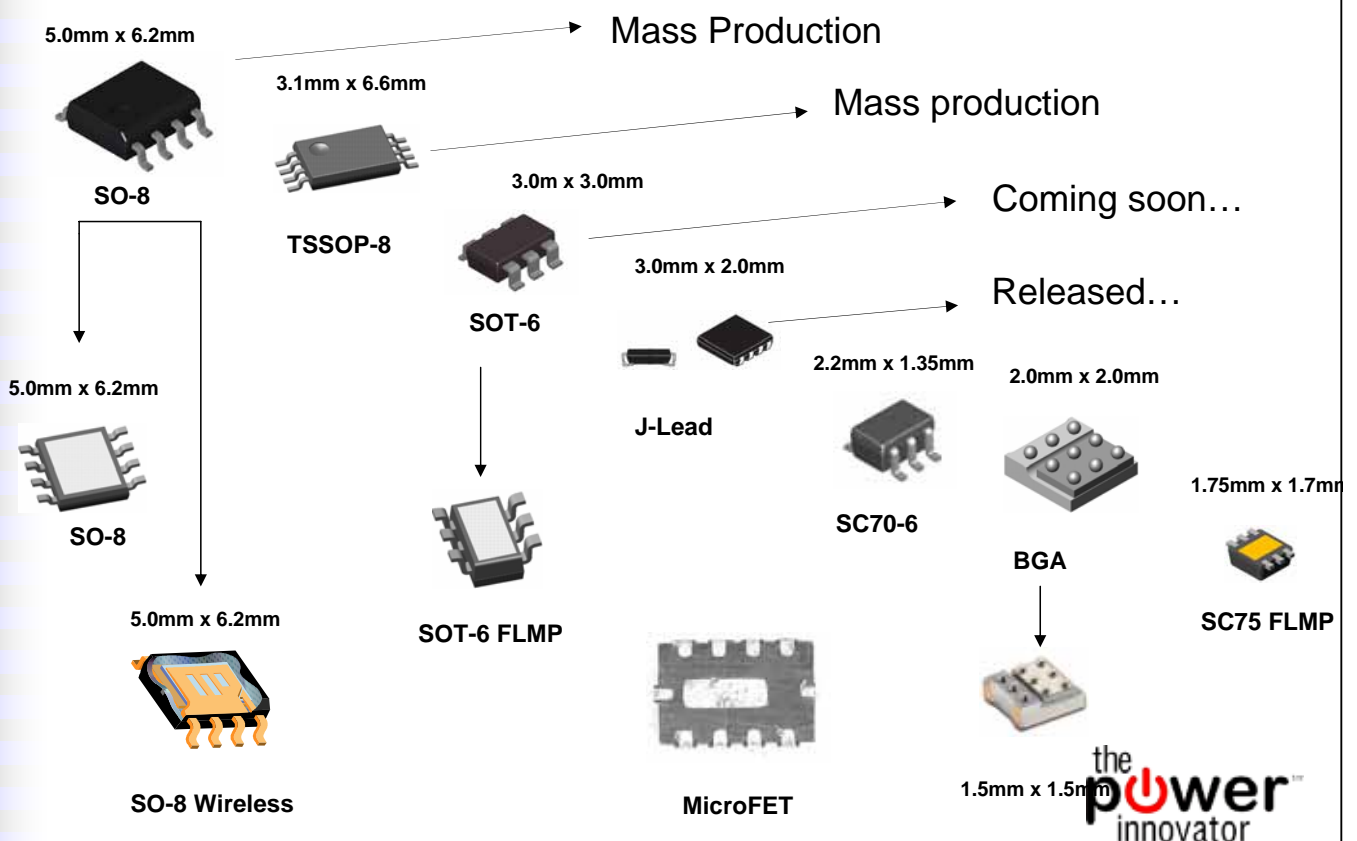

Cross Reference

CET Part	Fairchild	Sanyo	AOS	Vishay	Toshiba	ST Micro	Samhop
CEM9926A	FDS9926A	■	AO9926	SI9926A	■	■	SDM9926
CEG8205	FDW9926A	■	AO8822	■	TPCS8200	STC5NF20V	SDG8204
CEG8205A	FDW2512NZ	FDT2011	AO8822	SI4966	TPCS8205	STC5NF20V	SDG8204
	FDW2515NZ				TPCS8208	STC6NF30V	
CEJ8218	FDC6000NZ	ECH8601	■	■	■	■	■
CEG8208	FDW2509NZ	FDT2017	AO8810	SI6968	TPCS8212	■	STG8206
	FDW2511NZ						

the
power
innovator™

Contact Fairtek

飞泰科技有限公司

FAIRTEK INTERNATIONAL LIMITED

TEL:+86-755-8386-7800

FAX:+86-755-8358-1698

E-mail: sales@fairtek.com.cn

Web: www.fairtek.com.cn

地址：深圳市深南大道6007号创展中心910室

the
power
innovator™



飛泰科技，電源專家。

www.fairtek.com.cn

