

APPLICATION NOTE

**CFL applications with the
UBA2024T**

APPLICATION NOTE

**CFL applications with the
UBA2024T**

Author(s):

Joost Bongers, Arjan van den Berg, Ben Verhoeven
Philips Semiconductors, Standard Analogue Business line, Nijmegen, The Netherlands

Keywords:

Compact Fluorescent Lamp
Quasi preheat
UBA2024T
Integrated half bridge driver
Silicon On Insulator

Date: 2003-August-25

1	INTRODUCTION	4
2	FEATURES	4
3	Application photos	5
4	Circuit Diagram	6
5	SELECTING COMPONENT VALUES	7
5.1	<i>Selecting input configuration, buffer capacitor and fuse-resistor</i>	7
5.2	<i>Choosing frequency, lamp inductor and lamp capacitor</i>	7
5.3	<i>Ignition frequency and preheating</i>	9
5.4	<i>Choosing the other components</i>	9
5.5	<i>About component tolerances</i>	9
6	EXAMPLES OF CALCULATING COMPONENT VALUES	11
6.1	<i>EXAMPLE 1: a 3W lamp (2.5W/90mA burner)</i>	11
	Determining component values for 115V/60Hz mains.....	11
	Determining component values for 230V/50Hz mains.....	11
6.2	<i>EXAMPLE 2: a 14W lamp (12W/150mA burner, suited for cold ignition)</i>	12
	Determining component values for 115V/60Hz mains.....	12
	Determining component values for 230V/50Hz mains.....	12
6.3	<i>Some other examples</i>	13
	8W lamp (7W/150mA burner, suited for cold ignition) ($f_{out}=46kHz$).....	13
	11W lamp (9.5W/150mA burner, suited for cold ignition) ($f_{out}=42.5kHz$).....	13
	13W lamp (11W/125mA burner, needing warm ignition) ($f_{out}=42.5kHz$).....	14
	15W lamp (12.5W/180mA burner, suited for cold ignition) ($f_{out}=40kHz$).....	14
	12W DEMO BOARD LAMP :.....	15
7	QUICK MEASUREMENTS	16
	APPENDIX 1 Application board layout example.....	18

1 INTRODUCTION

The UBA2024T is an integrated half bridge power IC, designed for use in an integrated / sealed Compact Fluorescent Lamp (CFL) with a lamp current up to 150mA. Typical input voltages are 100-127Vac and 220-240Vac. Output power varies from 3 to 15W, depending on lamp and input voltage.

The UBA2024T is a high voltage (550V) monolithic integrated circuit made in the EZ-HV SOI process. It includes both half bridge power transistors with level-shifter and drivers, boots trap circuitry, an internal power supply, a precision oscillator and a start-up frequency sweep function for soft-start and/or pre-heating. It is mounted in a dedicated SO14 (Small Outline) package with optimised heat transfer.

Due to the high level of integration, only few external components are needed when building a lamp ballast with the UBA2024T. This application note will give descriptions of typical integrated CFL applications in the 3 to 15W range.

(See datasheet for functional description of the UBA2024T)

2 FEATURES

- based upon EZ-HV SOI (silicon on insulator) technology
- integrated half bridge power-IC for CFL applications (both powers and controller)
- accurate oscillator with adjustable frequency
- Soft start by frequency sweep down from start frequency
- Quasi preheat option (by use of larger sweep down timing)
- Allows for very compact integrated lamp ballast which fits a small shell
- Low cost Compact Fluorescent Lamp applications due to low component count
- Easy applicable
- Can withstand 550V maximum voltage surge

3 APPLICATION PHOTOS



Figure 1: Photos of a 14W Compact Fluorescent Lamp with UBA2024T

4 CIRCUIT DIAGRAM

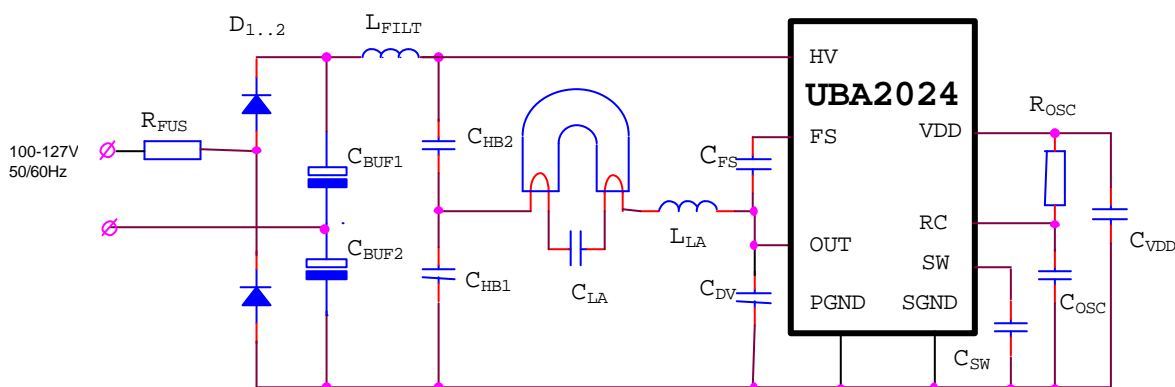

Figure 2: Schematic of Compact Fluorescent Lamp application using the UBA2024T with voltage doubler input

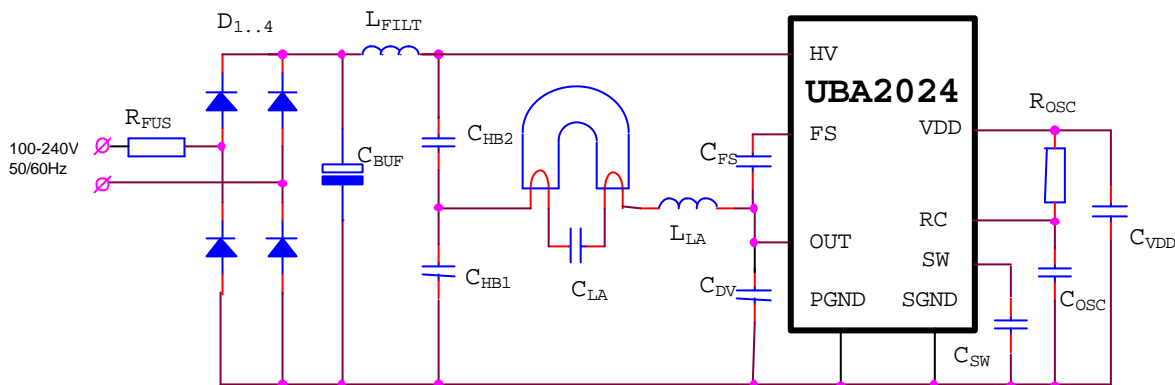

Figure 3: Schematic of standard Compact Fluorescent Lamp application using UBA2024T

PINNING SO14

SYMBOL	PIN	DESCRIPTION	SYMBOL	PIN	DESCRIPTION
SGND	1	signal ground	SW	8	input for sweep timing
SGND	2	signal ground	SGND	9	signal ground
SGND	3	signal ground	SGND	10	signal ground
HV	4	high voltage supply	FS	11	floating supply high side
SGND	5	signal ground	PGND	12	power ground
VDD	6	internal low voltage supply	SGND	13	signal ground
RC	7	input for internal oscillator	OUT	14	half bridge output

5 SELECTING COMPONENT VALUES

5.1 Selecting input configuration, buffer capacitor and fuse-resistor

Use of a voltage doubler (figure 2) or standard bridge rectifier (figure 3), values for the buffer capacitor (C_{BUF}) and the fusible inrush-current limiting resistor are given in table 2:

Table 2: Advised input configuration, buffer capacitor en fusible inrush-current limiting resistor

Input Voltage	Lamp Power [#]	Input configuration	C_{BUF}	C_{BUF1}, C_{BUF2} (each)	R_{FUS}
100-127Vac	≤ 4 W	Standard (fig. 4)	10μF/200V	(n.a.)	18Ω (0.25W/23W)*
100-127Vac	5 – 6 W		15μF/200V	(n.a.)	12Ω (0.5W/35W)*
100-127Vac	7 – 8 W	Voltage Doubler (fig.3)	(n.a.)	10μF/200V	10Ω (0.5W/47W)*
100-127Vac	9 – 11 W		(n.a.)	15μF/200V	8.2Ω (0.75W/70W)*
100-127Vac	12 – 14 W		(n.a.)	22μF/200V	6.8Ω (1W/103W)*
220-240Vac	≤ 5 W	Standard (fig. 4)	2.2μF/400V	(n.a.)	47Ω (0.25W/23W)*
220-240Vac	6 – 8 W		3.3μF/400V	(n.a.)	39Ω (0.25W/23W)*
220-240Vac	9 – 11 W		4.7μF/385V	(n.a.)	33Ω (0.5W/32W)*
220-240Vac	12 – 15 W		6.8μF/385V	(n.a.)	27Ω (0.5W/47W)*

([#] Overall lamp power including driver circuit)

(* Minimum continuous power rating / minimum peak power rating (≤20ms))

5.2 Choosing frequency, lamp inductor and lamp capacitor

Given a certain netto¹ lamp power P_{lamp} and lamp current I_{lamp} , then $V_{lamp} = P_{lamp} / I_{lamp}$. If buffer capacitors are according to table 2, an approximation of the effective lamp inductor voltage V_{Lla_eff} is given² in table 3:

Table 3: Approximated effective lamp inductor voltage

Input Voltage	frequency	Input configuration	V_{lamp}						V_{Lla_eff} [V]
			≤20V	≈30V	≈40V	≈50V	≈60V	≈80V	
100 Vac	60 Hz	Standard (fig. 4)	58	53	46	n.a.	n.a.	n.a.	n.a.
115 Vac			71	66	62	53	n.a.	n.a.	n.a.
127 Vac			80	76	70	65	n.a.	n.a.	n.a.
100 Vac	60 Hz	Voltage Doubler (fig.3)	123	120	117	113	108	94	n.a.
115 Vac			145	143	140	137	133	122	107
127 Vac			164	162	160	157	154	144	131
220 Vac	50 Hz	Standard (fig. 4)	138	136	133	130	125	112	95
230 Vac			145	143	140	138	134	122	106
240 Vac			153	151	148	146	143	131	116

n.a.= not applicable (these combinations of lamp voltage and input voltage/configuration are not allowed)

The lamp inductor L_{LA} and the lamp frequency f_{out} have to comply to:

$$2\pi f_{out} L_{LA} = \frac{V_{Lla_eff}}{I_{lamp}}$$

¹ of burner only, usually about 85% of overall lamp power.

² use linear interpolation to find values inbetween.

f_{out} can be chosen freely up to 60kHz (the maximum nominal output frequency for the UBA2024, corresponding with a start-up frequency of 150kHz, see datasheet for start-up sequence description). However, usually f_{out} is chosen between 25kHz and 30kHz or between 40kHz and 50kHz. This is because below 25kHz there may be audible noise, operation in the 30kHz to 40kHz band may result in interference with infra-red remote control and above 50kHz the third harmonic is in the range where conducted noise requirements for most countries have to be met. Since inductors and capacitors decrease in size and cost with increase in frequency, the 40 to 50kHz range is preferred. Throughout this application note we will presume the lamp frequency will be in this range.

f_{out} is set by R_{osc} and C_{osc} according to the following formula:

$$f_{out} = \frac{1}{k_{osc} R_{osc} C_{osc}}$$

Practical values for R_{osc} range from 50kΩ to 400kΩ. Note that the low values of R_{osc} will cause a larger VDD output current, thus increasing the total package dissipation. Practical values for C_{osc} range from 100pF to 1nF. Advised value for C_{osc} is 180pF for 40..50kHz and 270pF for 25..30kHz. The oscillator constant k_{osc} is shown in figure 4.

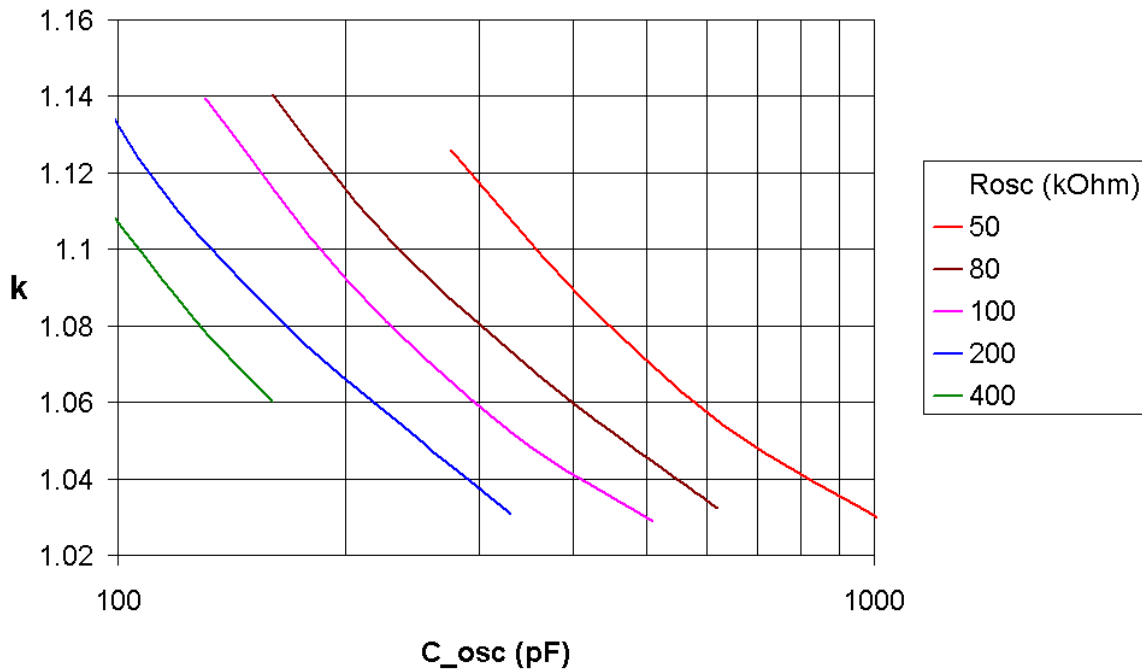

Figure 4: Typical k_{osc} dependency of R_{osc} and C_{osc} for UBA2024T.

5.3 Ignition frequency and preheating

The IC starts at an output frequency of about $2^{1/2}$ times the nominal output frequency, and gradually decreases this until the nominal output frequency is reached. The lamp inductor L_{LA} and the lamp capacitor C_{LA} will boost the lamp voltage gradually higher as the output frequency gets closer to their resonance frequency, until it is sufficient to ignite the lamp. In the mean time the current in the resonance circuit flows through the filaments thereby providing some preheating. The UBA2024 has a circuit that stops the frequency sweep at the resonance frequency if the lamp has not ignited yet (see UBA2024 specifications for details). This ensures maximum effort to ignite the lamp.

The ignition frequency f_{ign} is higher than or equal to the resonance frequency of L_{LA} and C_{LA} ($f_{res} = 1 / (2\pi\sqrt{L_{LA}C_{LA}})$). The resonance frequency should be chosen so that $1.6 \cdot f_{out} \leq f_{res} \leq 1.8 \cdot f_{out}$. The time needed to sweep down (set by C_{SW}) from the start frequency to f_{res} can be used as an approximation for the ignition time. It's about $0.5s/100nF$. For large values the ignition time is shorter, because the lamp ignites before the resonance frequency is reached. Typical ignition time is 1 s when $C_{SW} = 330nF$.

C_{SW} determines the sweep time. The larger C_{SW} , the longer the sweep time and better the preheating of the electrodes. However, the rise of the pre-ignition lamp voltage is also slower. Both a too short preheat as well as a too slow voltage rise increase the glow time of the lamp (that's when the lamp is not yet fully ignited, but it's not off anymore either), which decreases lamp life time. The best preheat time strongly depends on the lamp. Typical values for C_{SW} are 33nF to 330nF.

5.4 Choosing the other components

- For D1..D4 plain low cost 1N4007 diodes can be used.
- For lamp current $\geq 150mA$ $C_{DV} = 220pF$, for lower currents $C_{DV} = 100pF$.
- The values for C_{VDD} and C_{FS} are $C_{FS} = C_{VDD} = 10nF$.
- Advised half bridge capacitors (C_{HB1} and C_{HB2}) are $>47nF$ when $f_{out} = 40-50kHz$ and $>68nF$ when $f_{out} = 25-30kHz$.
- The resonance frequency of the input filter, consisting of L_{FILT} and C_{HB} (C_{HB} being de effective capacitor as seen on the HV pin of the IC, i.e. the series capacitance of C_{HB1} and C_{HB2}), has to be at least two times lower than the nominal output frequency.

Note: Performance and lifetime can not be guaranteed by using the values given in this chapter only. Lamp and UBA2024 performance strongly interact with each other and need to be qualified together as a combination.

5.5 About component tolerances

For all components, generally used tolerances can be used (20% for electrolytic capacitors, 10% for other capacitors (foil or ceramic) and 5% for resistors and inductors). Since R_{OSC} , C_{OSC} and L_{LA} determine the lamp current, their tolerance also determines the spread in the lamp current. Therefore, the required lamp current accuracy may require closer tolerance R_{OSC} , C_{OSC} and L_{LA} .

Example 1: $R_{OSC} \pm 5\%$, $C_{OSC} \pm 10\%$, $L_{LA} \pm 5\%$, $C_{LA} \pm 10\%$ and the IC's internal frequency $\pm 3\%$ then lamp current tolerance is 12.6% effective³.

³ Valid for component values with normal distribution.

Example 2: $R_{OSC} \pm 1\%$, $C_{OSC} \pm 5\%$, $L_{LA} \pm 5\%$, $C_{LA} \pm 5\%$ and the IC's internal frequency $\pm 3\%$ then lamp current tolerance is 7.1% effective.

6 EXAMPLES OF CALCULATING COMPONENT VALUES

6.1 EXAMPLE 1: a 3W lamp (2.5W/90mA burner)

Determining component values for 115V/60Hz mains

- From table 2: Standard configuration, $C_{BUF}=10\mu F$, $R_{FUS}=18\Omega$.
- $V_{lamp}\approx 2.5/0.090\approx 28V$. From table 3: Effective lamp coil voltage $V_{Lla_eff}\approx 68V$. For $L_{LA}=3.9mH$ the output frequency must be $f_{out}=68/(0.090\cdot 3.9\cdot 10^{-3}\cdot 2\cdot \pi)=30.8kHz$
- We choose $C_{OSC}=270pF$, then $R_{OSC}=1/(1.07\cdot 30.8\cdot 10^3\cdot 270\cdot 10^{-12})=112k\Omega$. To stay below 30kHz and within E24-range we choose $120k\Omega$, so $f_{out}=1/(1.07\cdot 120\cdot 10^3\cdot 270\cdot 10^{-12})=28.8kHz$.
- The only E12-range value of C_{LA} resulting in f_{ign}/f_{out} between 1.6 and 1.8 is: $2.7nF$ ($f_{ign}/f_{out}\approx 1.70$).
- Warm ignition. $C_{SW}=220nF$.
- $D_1..D_4=BYD13M$ (=1N4007 equivalent, but smaller), $C_{FS}=10nF$, $C_{VDD}=10nF$ and $C_{DV}=100pF$ (see section 6.4).
- $C_{HB1}=C_{HB2}=33nF$ (see section 6.4). L_{FILT} is chosen 4.7mH.

Determining component values for 230V/50Hz mains

- From table 2: Standard configuration, $C_{BUF}=2.2\mu F$, $R_{FUS}=47\Omega$.
- $V_{lamp}\approx 2.5/0.090\approx 28V$. From table 3: Effective lamp coil voltage $V_{Lla_eff}\approx 143V$. For $L_{LA}=8.2mH$ the output frequency must be $f_{out}=143/(0.090\cdot 8.2\cdot 10^{-3}\cdot 2\cdot \pi)=30.8kHz$
- We choose $C_{OSC}=270pF$, then $R_{OSC}=1/(1.07\cdot 30.8\cdot 10^3\cdot 270\cdot 10^{-12})=112k\Omega$. To stay below 30kHz and within E24-range we choose $120k\Omega$, so $f_{out}=1/(1.07\cdot 120\cdot 10^3\cdot 270\cdot 10^{-12})=28.8kHz$.
- The only E6-range value of C_{LA} resulting in f_{ign}/f_{out} between 1.6 and 1.8 is $1.0nF$ ($f_{ign}/f_{out}\approx 1.76$).
- Warm ignition: $C_{SW}=220nF$.
- $D_1..D_4=BYD13M$ (=1N4007 equivalent, but smaller), $C_{FS}=10nF$, $C_{VDD}=10nF$ and $C_{DV}=100pF$ (see section 6.4).
- $C_{HB1}=C_{HB2}=47nF$ (see section 6.4). L_{FILT} is chosen 4.7mH.

REF	DESCRIPTION	REMARKS	115V/60HZ	230V/50Hz
R_{FUS}	Fusible inrush current limiter resistor	<i>Special type, fusible, high peak power</i>	18 Ω	47 Ω
$D_1..D_4$	Bridge rectifier diodes		BYD13M	BYD13M
C_{BUF}	Buffer capacitor	<i>High temperature electrolytic type</i>	10 $\mu F/200V$	2.2 $\mu F/400V$
L_{FILT}	Filter inductor	<i>Axial type</i>	4.7mH	4.7mH
C_{HB1}, C_{HB2}	Half bridge capacitors		47nF/200V _{dc}	47nF/200V _{dc}
C_{LA}	Lamp capacitor	<i>Foil type</i>	2.7nF/1kV _{dc}	1.0nF/1kV _{dc}
L_{LA}	Lamp inductor	<i>BC7/12-Core (illustration at the side)</i>	3.9mH	8.2mH
C_{DV}	dV/dt limiting capacitor		100pF/500V _{dc}	100pF/500V _{dc}
C_{FS}	Floating Supply buffer capacitor		10nF/50V	10nF/50V
C_{VDD}	low voltage supply buffer capacitor		10nF/50V	10nF/50V
C_{OSC}	Oscillator capacitor		270pF/50V	270pF/50V
R_{OSC}	Oscillator resistor		120k Ω /1/8W	120k Ω /1/8W
C_{SW}	Sweep time capacitor		220nF/16V	220nF/16V

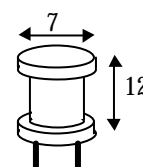

6.2 EXAMPLE 2: a 14W lamp (12W/150mA burner, suited for cold ignition)

Determining component values for 115V/60Hz mains

- 1) From table 2: Voltage doubler configuration, $C_{BUF1}=C_{BUF2}=22\mu\text{F}$, $R_{FUS}=6.8\Omega$
- 2) $V_{lamp}\approx 12/0.150=80\text{V}$. From table 3: Effective lamp coil voltage $V_{Lla_eff}\approx 122\text{V}$. For $L_{LA}=3.1\text{mH}$ the output frequency must be $f_{out}=122/(0.150\cdot 3.1\cdot 10^{-3}\cdot 2\cdot \pi)=41.8\text{kHz}$.
- 3) We choose $C_{OSC}=180\text{pF}$, then $R_{OSC}=1/(1.09\cdot 41.8\cdot 10^3\cdot 180\cdot 10^{-12})=122\text{k}\Omega$. To stay within E24-range we choose $120\text{k}\Omega$, so $f_{out}=1/(1.09\cdot 120\cdot 10^3\cdot 180\cdot 10^{-12})=42.5\text{kHz}$.
- 4) The only E6-range value of C_{LA} resulting in f_{ign}/f_{out} between 1.6 and 1.8 is 1.5nF ($f_{ign}/f_{out}\approx 1.74$).
- 5) This burner is suited for cold ignition: $C_{SW}=100\text{nF}$ (see paragraph 5.3)
- 6) $D_1=D_2=1\text{N}4007$, $C_{FS}=10\text{nF}$, $C_{VDD}=10\text{nF}$ and $C_{DV}=220\text{pF}$ (see section 6.4).
- 7) $C_{HB1}=C_{HB2}=47\text{nF}$ (see section 6.4). L_{FILT} is chosen 2.7mH .

Determining component values for 230V/50Hz mains

- 1) From table 2: Standard configuration, $C_{BUF}=6.8\mu\text{F}$, $R_{FUS}=27\Omega$
- 2) $V_{lamp}\approx 12/0.150=80\text{V}$. From table 3: Effective lamp coil voltage $V_{Lla_eff}\approx 122\text{V}$. For $L_{LA}=3.1\text{mH}$ the output frequency must be $f_{out}=122/(0.150\cdot 3.1\cdot 10^{-3}\cdot 2\cdot \pi)=41.8\text{kHz}$.
- 3) We choose $C_{OSC}=180\text{pF}$, then $R_{OSC}=1/(1.09\cdot 41.8\cdot 10^3\cdot 180\cdot 10^{-12})=122\text{k}\Omega$. To stay within E24-range we choose $120\text{k}\Omega$, so $f_{out}=1/(1.09\cdot 120\cdot 10^3\cdot 180\cdot 10^{-12})=42.5\text{kHz}$.
- 4) The only E6-range value of C_{LA} resulting in f_{ign}/f_{out} between 1.6 and 1.8 is 1.5nF ($f_{ign}/f_{out}\approx 1.74$).
- 5) For cold ignition $C_{SW}=33\text{nF}$ (see paragraph 5.3)
- 6) $D_1..D_4=1\text{N}4007$, $C_{FS}=10\text{nF}$, $C_{VDD}=10\text{nF}$ and $C_{DV}=220\text{pF}$ (see section 6.4).
- 7) $C_{HB1}=C_{HB2}=47\text{nF}$ (see section 6.4). L_{FILT} is chosen 2.7mH .

REF	DESCRIPTION	REMARKS	115V/60HZ	230V/50HZ
R_{FUS}	Fusible inrush current limiter resistor	<i>Special type, fusible, high peak power</i>	6.8Ω	27Ω
D_1, D_2	Voltage doubler diodes		1N4007	
$D_1..D_4$	Bridge rectifier diodes			1N4007
C_{BUF1}, C_{BUF2}	Buffer capacitors	<i>High temperature electrolytic type</i>	$22\mu\text{F}/200\text{V}$	
C_{BUF}	Buffer capacitor	<i>High temperature electrolytic type</i>		$6.8\mu\text{F}/400\text{V}$
L_{FILT}	Filter inductor	<i>Axial type</i>	2.7mH	2.7mH
C_{HB1}, C_{HB2}	Half bridge capacitors		$47\text{nF}/200\text{V}_{dc}$	$47\text{nF}/200\text{V}_{dc}$
C_{LA}	Lamp capacitor	<i>Foil type, capable of withstanding peak voltages of twice it's dc rating</i>	$1.5\text{nF}/400\text{V}_{dc}$	$1.5\text{nF}/400\text{V}_{dc}$
L_{LA}	Lamp inductor	<i>E-16-Core</i>	3.1mH	3.1mH
C_{DV}	dV/dt limiting capacitor		$220\text{pF}/500\text{V}_{dc}$	$220\text{pF}/500\text{V}_{dc}$
C_{FS}	Floating Supply buffer capacitor		$10\text{nF}/50\text{V}$	$10\text{nF}/50\text{V}$
C_{VDD}	low voltage supply buffer capacitor		$10\text{nF}/50\text{V}$	$10\text{nF}/50\text{V}$
C_{OSC}	Oscillator capacitor		$180\text{pF}/50\text{V}$	$180\text{pF}/50\text{V}$
R_{OSC}	Oscillator resistor		$120\text{k}\Omega/1/8\text{W}$	$120\text{k}\Omega/1/8\text{W}$
C_{SW}	Sweep time capacitor		$100\text{nF}/25\text{V}$	$33\text{nF}/50\text{V}$

6.3 Some other examples

8W lamp (7W/150mA burner, suited for cold ignition) ($f_{out}=46\text{kHz}$)

REF	DESCRIPTION	REMARKS	115V/60HZ	230V/50Hz
R_{FUS}	Fusible inrush current limiter resistor	<i>Special type, fusible, high peak power</i>	10 Ω	39 Ω
D_1, D_2	Voltage doubler diodes		1N4007	
$D_1..D_4$	Bridge rectifier diodes			1N4007
C_{BUF1}, C_{BUF2}	Buffer capacitors	<i>High temperature electrolytic type</i>	10 $\mu\text{F}/200\text{V}$	
C_{BUF}	Buffer capacitor	<i>High temperature electrolytic type</i>		3.3 $\mu\text{F}/400\text{V}$
L_{FILT}	Filter inductor	<i>Axial type</i>	2.2mH	2.2mH
C_{HB1}, C_{HB2}	Half bridge capacitors		47nF/200V $_{dc}$	47nF/200V $_{dc}$
C_{LA}	Lamp capacitor	<i>Foil type, capable of withstanding peak voltages of twice it's dc rating</i>	1.5nF/400V $_{dc}$	1.5nF/400V $_{dc}$
L_{LA}	Lamp inductor	<i>E-16-Core</i>	3.1mH	3.1mH
C_{DV}	dV/dt limiting capacitor		220pF/500V $_{dc}$	220pF/500V $_{dc}$
C_{FS}	Floating Supply buffer capacitor		10nF/50V	10nF/50V
C_{VDD}	low voltage supply buffer capacitor		10nF/50V	10nF/50V
C_{OSC}	Oscillator capacitor		180pF/50V	180pF/50V
R_{OSC}	Oscillator resistor		110k $\Omega/1/8\text{W}$	110k $\Omega/1/8\text{W}$
C_{SW}	Sweep time capacitor		100nF/25V	33nF/50V

11W lamp (9.5W/150mA burner, suited for cold ignition) ($f_{out}=42.5\text{kHz}$)

REF	DESCRIPTION	REMARKS	115V/60HZ	230V/50Hz
R_{FUS}	Fusible inrush current limiter resistor	<i>Special type, fusible, high peak power</i>	8.2 Ω	33 Ω
D_1, D_2	Voltage doubler diodes		1N4007	
$D_1..D_4$	Bridge rectifier diodes			1N4007
C_{BUF1}, C_{BUF2}	Buffer capacitors	<i>High temperature electrolytic type</i>	15 $\mu\text{F}/200\text{V}$	
C_{BUF}	Buffer capacitor	<i>High temperature electrolytic type</i>		4.7 $\mu\text{F}/400\text{V}$
L_{FILT}	Filter inductor	<i>Axial type</i>	2.7mH	2.7mH
C_{HB1}, C_{HB2}	Half bridge capacitors		47nF/200V $_{dc}$	47nF/200V $_{dc}$
C_{LA}	Lamp capacitor	<i>Foil type, capable of withstanding peak voltages of twice it's dc rating</i>	1.5nF/400V $_{dc}$	1.5nF/400V $_{dc}$
L_{LA}	Lamp inductor	<i>E-16-Core</i>	3.1mH	3.1mH
C_{DV}	dV/dt limiting capacitor		220pF/500V $_{dc}$	220pF/500V $_{dc}$
C_{FS}	Floating Supply buffer capacitor		10nF/50V	10nF/50V
C_{VDD}	low voltage supply buffer capacitor		10nF/50V	10nF/50V
C_{OSC}	Oscillator capacitor		180pF/50V	180pF/50V
R_{OSC}	Oscillator resistor		120k $\Omega/1/8\text{W}$	120k $\Omega/1/8\text{W}$
C_{SW}	Sweep time capacitor		100nF/25V	33nF/50V

13W lamp (11W/125mA burner, needing warm ignition) ($f_{out}=42.5\text{kHz}$)

REF	DESCRIPTION	REMARKS	115V/60HZ	230V/50Hz
R_{FLUS}	Fusible inrush current limiter resistor	<i>Special type, fusible, high peak power</i>	6.8 Ω	27 Ω
D_1, D_2	Voltage doubler diodes		1N4007	
$D_1..D_4$	Bridge rectifier diodes			1N4007
C_{BUF1}, C_{BUF2}	Buffer capacitors	<i>High temperature electrolytic type</i>	22 $\mu\text{F}/200\text{V}$	
C_{BUF}	Buffer capacitor	<i>High temperature electrolytic type</i>		6.8 $\mu\text{F}/400\text{V}$
L_{FILT}	Filter inductor	<i>Axial type</i>	3.9mH	3.9mH
C_{HB1}, C_{HE2}	Half bridge capacitors		33nF/200V _{dc}	33nF/200V _{dc}
C_{LA}	Lamp capacitor	<i>Foil type, capable of withstanding peak voltages of twice it's dc rating</i>	1.5nF/400V _{dc}	1.5nF/400V _{dc}
L_{LA}	Lamp inductor	<i>E-16-Core</i>	3.5mH	3.5mH
C_{DV}	dV/dt limiting capacitor		100pF/500V _{dc}	100pF/500V _{dc}
C_{FS}	Floating Supply buffer capacitor		10nF/50V	10nF/50V
C_{VDD}	low voltage supply buffer capacitor		10nF/50V	10nF/50V
C_{OSC}	Oscillator capacitor		180pF/50V	180pF/50V
R_{OSC}	Oscillator resistor		120k Ω /1/8W	120k Ω /1/8W
C_{SW}	Sweep time capacitor		470nF/16V	330nF/16V

15W lamp (12.5W/180mA burner, suited for cold ignition) ($f_{out}=40\text{kHz}$)

REF	DESCRIPTION	REMARKS	230V/50Hz
R_{FLUS}	Fusible inrush current limiter resistor	<i>Special type, fusible, high peak power</i>	27 Ω
$D_1..D_4$	Bridge rectifier diodes		1N4007
C_{BUF}	Buffer capacitor	<i>High temperature electrolytic type</i>	6.8 $\mu\text{F}/400\text{V}$
L_{FILT}	Filter inductor	<i>Axial type</i>	3.3mH
C_{HB1}, C_{HE2}	Half bridge capacitors		47nF/200V _{dc}
C_{LA}	Lamp capacitor	<i>Foil type, capable of withstanding peak voltages of twice it's dc rating</i>	1.8nF/400V _{dc}
L_{LA}	Lamp inductor	<i>E-16-Core</i>	3.1mH
C_{DV}	dV/dt limiting capacitor		220pF/500V _{dc}
C_{FS}	Floating Supply buffer capacitor		10nF/50V
C_{VDD}	low voltage supply buffer capacitor		10nF/50V
C_{OSC}	Oscillator capacitor		180pF/50V
R_{OSC}	Oscillator resistor		130k Ω /1/8W
C_{SW}	Sweep time capacitor		68nF/50V

12W DEMO BOARD LAMP :12W lamp (150mA burner, cold ignition, $f_{out}=46kHz$)

REF	DESCRIPTION	REMARKS	230V/50Hz
R_{FUS}	Fusible inrush current limiter resistor	<i>Special type, fusible, high peak power</i>	10 Ω
$D_1..D_4$	Bridge rectifier diodes		1N4007
C_{BUF}	Buffer capacitor	<i>High temperature electrolytic type</i>	3.3 μ F/400V
L_{FILT}	Filter inductor	<i>Axial type</i>	1.8mH
C_{HB1}, C_{HE2}	Half bridge capacitors		100nF/200V _{dc}
C_{LA}	Lamp capacitor	<i>Foil type, capable of withstanding peak voltages of twice it's dc rating</i>	2.2nF/400V _{dc}
L_{LA}	Lamp inductor	<i>E-16-Core</i>	2.7mH
C_{DV}	dV/dt limiting capacitor		220pF/500V _{dc}
C_{FS}	Floating Supply buffer capacitor		10nF/50V
C_{VDD}	low voltage supply buffer capacitor		10nF/50V
C_{OSC}	Oscillator capacitor		180pF/50V
R_{OSC}	Oscillator resistor		110k Ω / 1/8W
C_{SW}	Sweep time capacitor		33nF/50V

7 QUICK MEASUREMENTS

Table 4: Measured values compared with calculated values

Lamp power	Input voltage /frequency ⁴	Input configuration	preheat	f _{out} set	f _{out} measured ⁵	I _{lamp} calculated using f _{out}	I _{lamp} measured
3W	115V/50Hz	standard	Yes	28.8kHz	29.1kHz	95mA	97mA
3W	230V/50Hz	standard	Yes	28.8kHz	29.0kHz	96mA	94mA
8W	115V/60Hz	doubler	No	45.9kHz	48.7kHz	145mA	138mA
8W	230V/50Hz	standard	No	45.9kHz	48.6kHz	147mA	144mA
11W	115V/60Hz	doubler	No	42.5kHz	45.1kHz	148mA	142mA
11W	230V/50Hz	standard	No	42.5kHz	44.7kHz	150mA	148mA
13W	115V/60Hz	doubler	maximum	42.5kHz	44.0kHz	120mA	115mA
13W	230V/50Hz	standard	maximum	42.5kHz	44.0kHz	120mA	127mA
14W	115V/60Hz	doubler	No	42.5kHz	45.2kHz	139mA	129mA
14W	230V/50Hz	standard	No	42.5kHz	44.8kHz	140mA	141mA
15W	230V/50Hz	standard	No	39.7kHz	41.4kHz	161mA	171mA

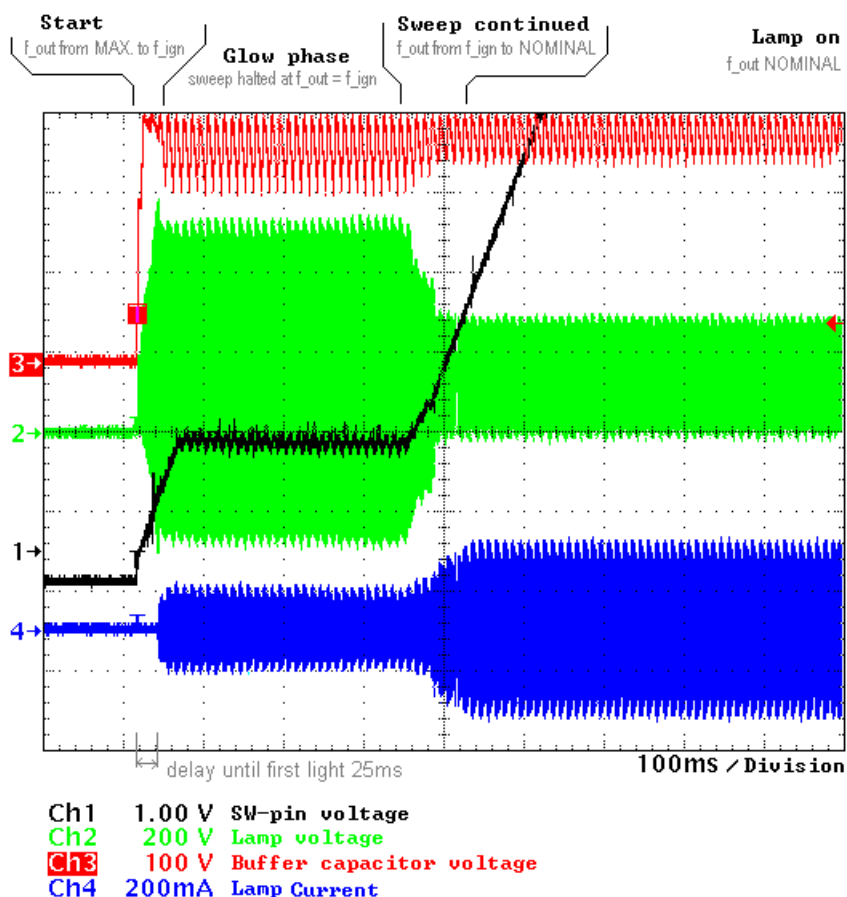

Figure 5: Cold starting lamp waveforms.
(C_{SW}=10nF)

⁴ Measurement for 115V/60Hz were done at 115V/50Hz with 15% extra capacitance added to C_{BUF1} and C_{BUF2}.

⁵ A 5% resistor was used for R_{osc}, and a 10% capacitor was used for C_{osc}. Tolerances of R_{osc} and C_{osc} both add to frequency tolerance of IC. Use R_{osc} and C_{osc} with less tolerance if better match between calculated and measured frequency is needed.

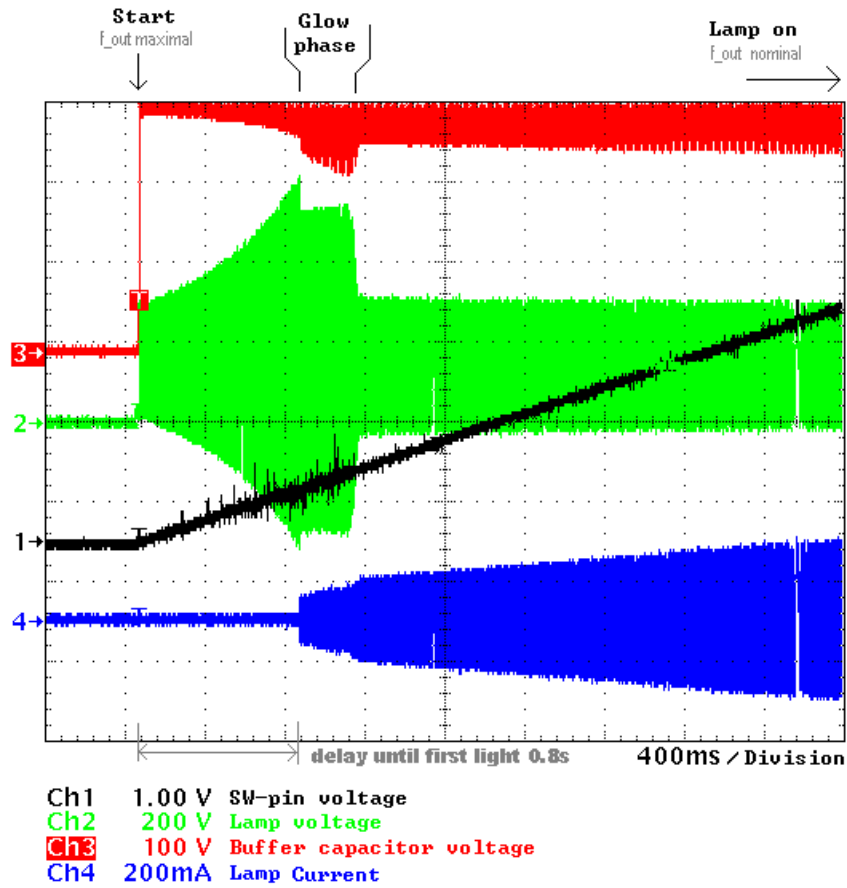

Figure 6: Lamp start-up with 'warm' ignition.
($C_{SW}=330nF$)

APPENDIX 1 Application board layout example

The layout of the PCB on which the UBA2024T is mounted, has a considerable influence on the performance of the IC. Issues to be taken into account are:

- Coils with open magnetic circuit should not be placed above the IC (on the other side of the PCB). If an axial filter inductor is used for L_{FILT} it should be placed in the same direction as the IC to minimize magnetic field pick-up.
- All output components (C_{HB1} , C_{HB2} , L_{LA} , C_{LA} and C_{DV}) and their interconnections should be placed at the side of pin 1 and pin 14 of the IC.
- Oscillator pin (pin 7, “RC”) and sweep pin (pin 8, “SW”) should be shielded from output/lamp by a ground track. Components on these pins should be placed as close to the IC as possible.
- Capacitors C_{VDD} and C_{FS} should be placed close to the IC.
- For effective heat transfer all SGND pins need to be soldered to a copper plane which is also beneath the IC and extends besides the IC as much as possible. Fixing the IC to the board using thermal conductive glue also helps.

Of course, the size and shape of the PCB has to fit the lamp base. Below the layout of the demoboard, as is used for the measurements mentioned in this application note, is shown as an example. With it’s diameter of only 35mm it’s smaller than most currently used CFL-ballast PCBs. It’s suited for either use of the popular E16 core lamp inductor or a radial-type I-core inductor.

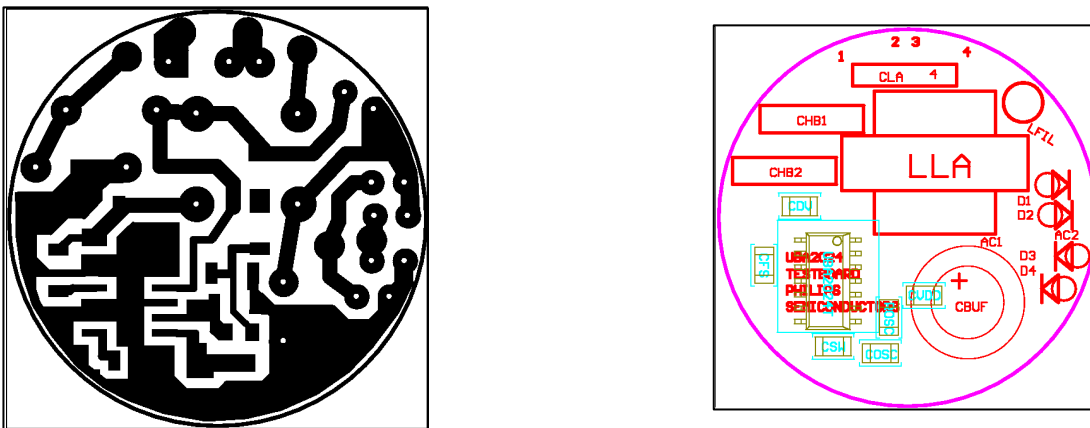

Figure 7: Layout (left) and component placement (right) of application demoboard (actual size is 35mm diameter)