

AUDIO FREQUENCY POWER AMPLIFIER LOW SPEED SWITCHING

- Complement to PJB772
- PW 10ms, Duty Cycle 50% Pulse Test
- PW 350μs, Duty Cycle 2%

ABSOLUTE MAXIMUM RATINGS (T_a = 25 °C)

Characteristic	Symbol	Rating	Unit
Collector-Base Voltage	V _{CB0}	40	V
Collector-Emitter Voltage	V _{CEO}	30	V
Emitter-Bias Voltage	V _{EBO}	5	V
Collector Current (DC)	I _C	3	A
*Collector Current (Pulse)	I _C	7	A
Base Current (DC)	I _B	0.6	A
Collector Dissipation (T _a =25°C)	P _C	10	W
Collector Dissipation (T _a =25°C)	P _C	1	W
Junction Temperature	T _j	150	°C
Storage Temperature	T _{stg}	-55~150	°C

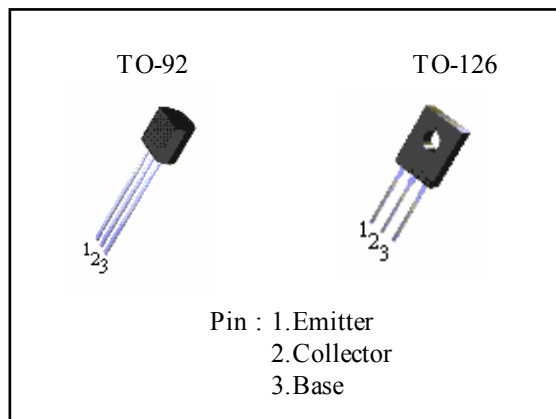

ORDERING INFORMATION

Device	Operating Temperature	Package
PJD882CT	-20°C ~ +85°C	TO-92
PJD882CK		TO-126

ELECTRICAL CHARACTERISTICS (T_a=25°C)

Characteristics	Symbol	Test condition	Min	Typ	Min	Unit
Collector Cutoff Current	I _{CB0}	V _{CB} =30V, I _E =0			1	μA
Emitter Cutoff Current	I _{EBO}	V _{EB} =3V, I _C =0			1	μA
*DC Current Gain	h _{FE1}	V _{CE} =2V, I _C =20mA	30	150		
	h _{FE2}	V _{CE} =2V, I _C =1A	60	160	400	
*Collector Emitter Saturation Voltage	V _{CE(SAT)}	I _C =2A, I _B =0.2A		0.3	0.5	V
*Base Emitter Saturation Voltage	V _{BE(SAT)}	I _C =2A, I _B =0.2A		1.0	2.0	V
Current Gain Bandwidth Product	f _T	V _{CE} =5V, I _C =0.1A		90		MHz
Output Capacitance	C _{ob}	V _{CB} =10V, I _E =0 f=1MHz		45		pF

h_{FE}(2) CLASSIFICATION

Classification	R	O	Y	G
h _{FE} (2)	60-120	100-200	160-320	200-400

STATIC CHARACTERISTIC

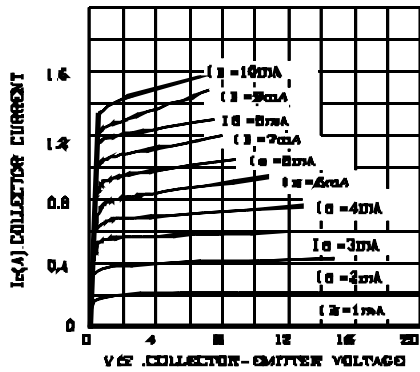

CURRENT GAIN-BANDWIDTH PRODUCT

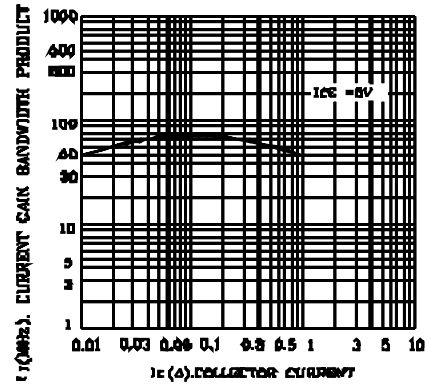

BASE-EMITTER SATURATION VOLTAGE
COLLECTOR-EMITTER SATURATION VOLTAGE

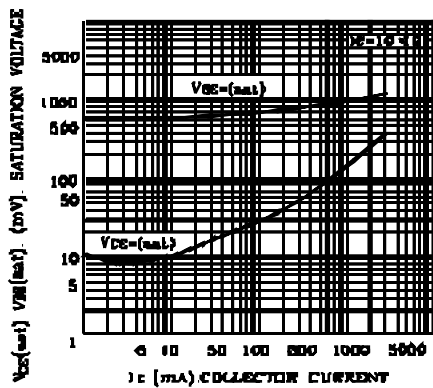

SAFE OPERATING AREAS

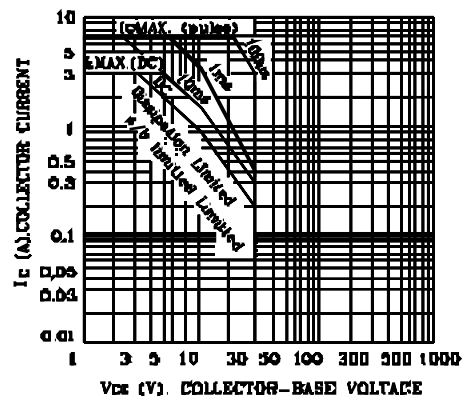

COLLECTOR OUTPUT CAPACITANCE

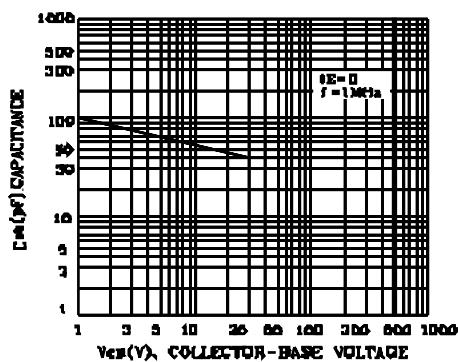

DERATING CURVE OF SAFE OPERATING AREAS

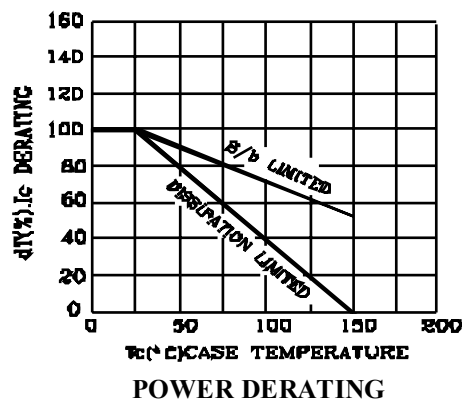

DC CURRENT GAIN

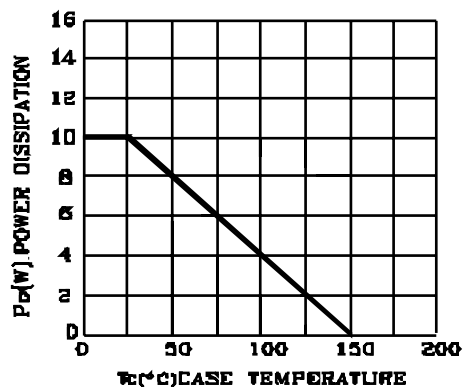
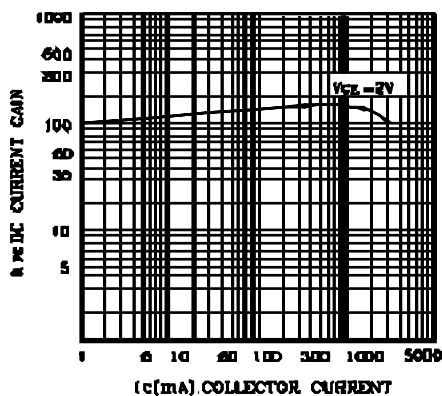

TO-92 Unit:mm

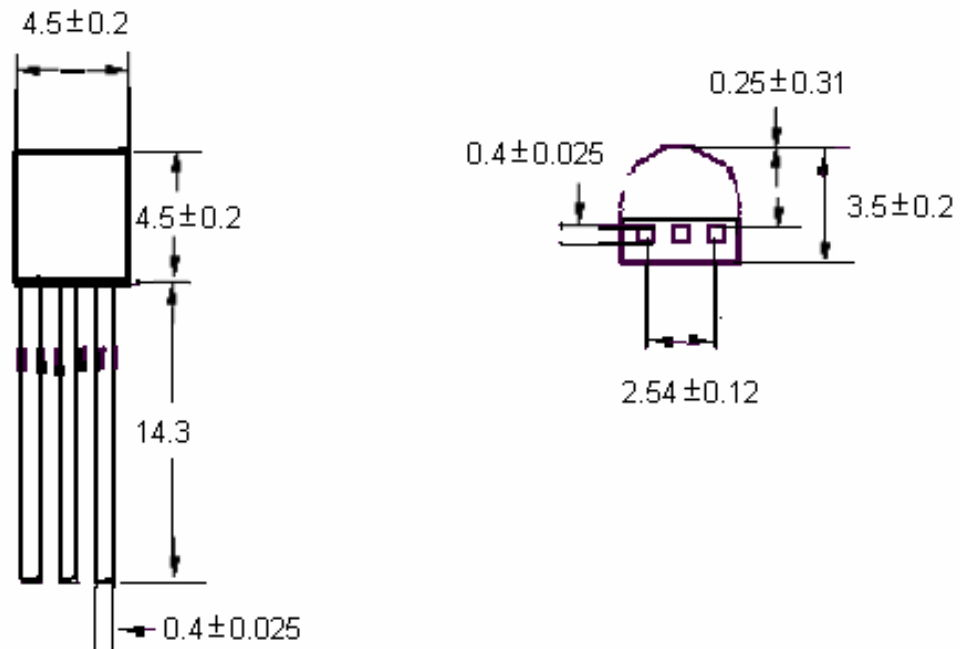

TO-126 Unit:mm

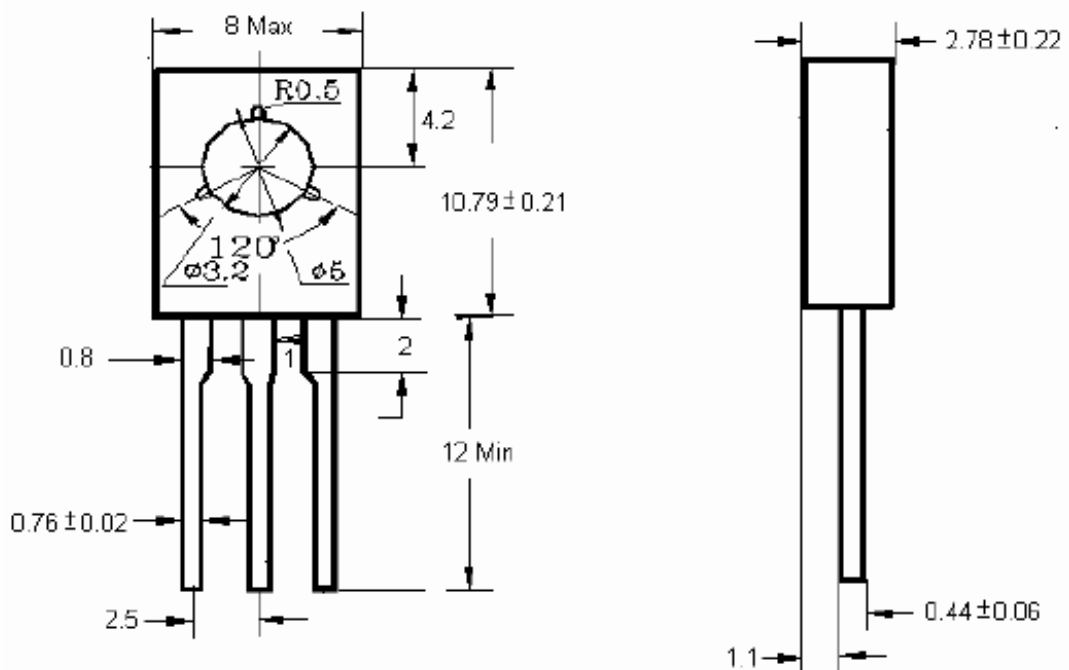

Copyright © Each Manufacturing Company.

All Datasheets cannot be modified without permission.

This datasheet has been download from :

www.AllDataSheet.com

100% Free DataSheet Search Site.

Free Download.

No Register.

Fast Search System.

www.AllDataSheet.com