

1 CHANNEL SYNCHRONOUS PWM CONTROL IC

GENERAL DESCRIPTION

The **FP5137** is a synchronous buck switching regulator control IC for DC-DC applications field. The **FP5137** includes a totem-pole high/low side stage for driving NMOS, high precision reference (1.25V) for comparing output voltage with feedback amplifier, an internal **200KHz** oscillator and programmable soft start function.

FEATURES

- Feedback Reference Voltage: 1.25V (2%)
- Peak Output Source/Drive Capability: 500mA
- Internal 200KHz Oscillator
- Programmable Soft Start function (SS)
- Short Circuit Protection function(SCP)
- Internal UVLO function
- Package: PDIP8/SOP8

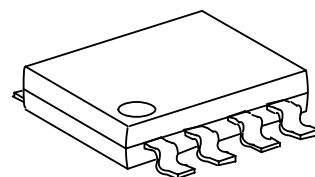

SOP8

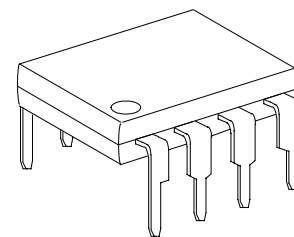

PDIP8

TYPICAL APPLICATION

- VGA Card
- High Efficiency DC-DC Converter
- Battery Charger

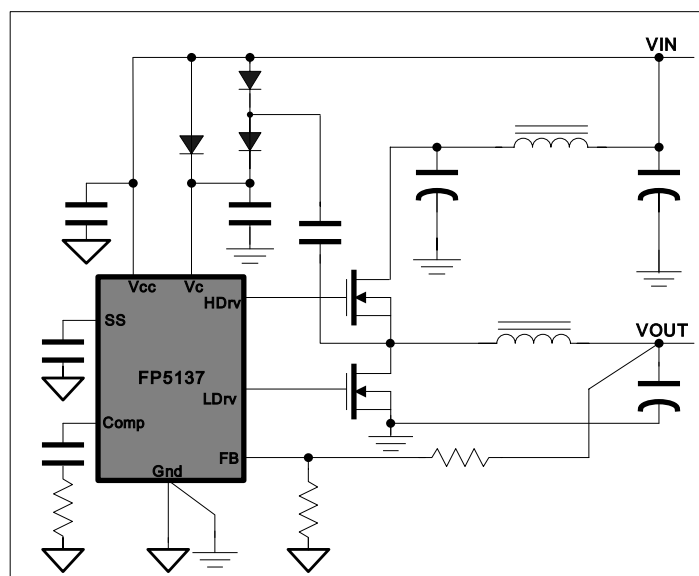

FUNCTIONAL BLOCK DIAGRAM

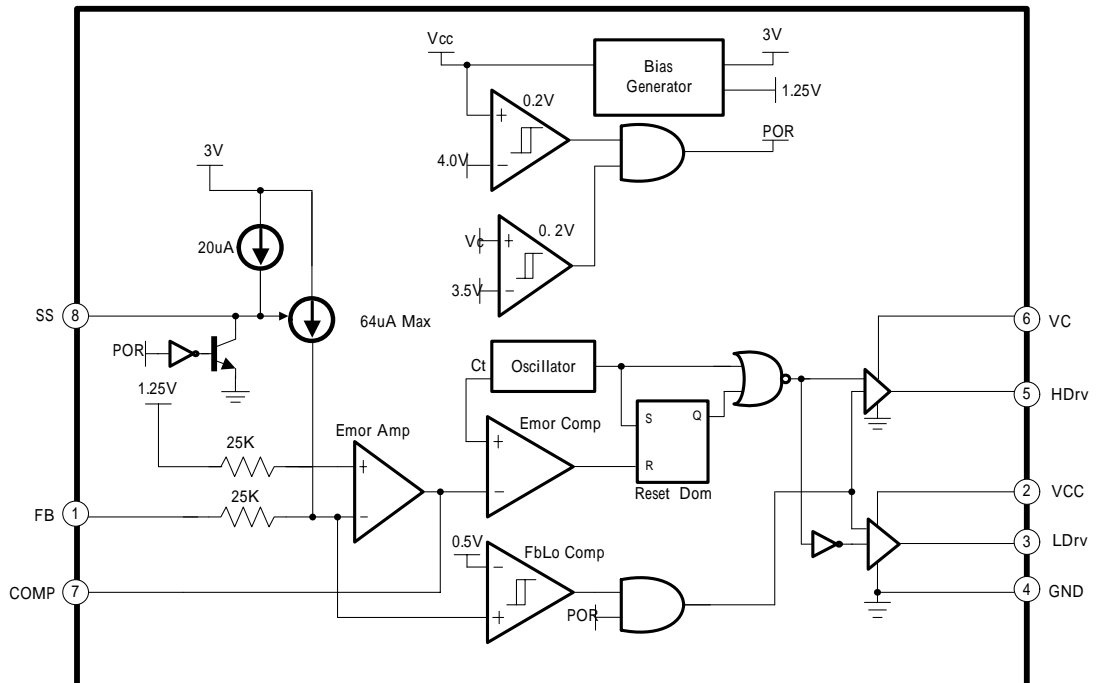

MARK VIEW

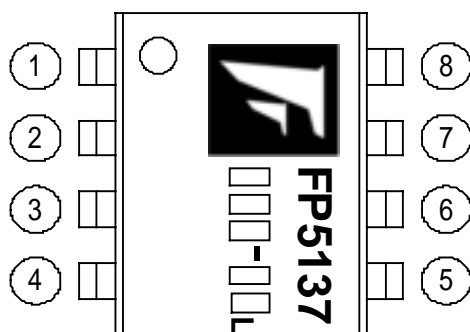

PIN DESCRIPTION

Name	No.	I/O	Description
FB	1	I	Error amplifier inverting input pin
V _{CC}	2	P	IC power supply
LDRV	3	O	Low Side NMOS Driver
GND	4	P	IC ground
HDRV	5	O	High Side NMOS Driver
V _C	6	P	A supply voltage for High Side Driver
COMP	7	O	Error amplifier compensation output
SS	8	I	To connect a capacitor for Soft-start

ORDER INFORMATION

Part Number	Operating Temperature	Package	Description
FP5137P-LF	-10°C ~ +85°C	PDIP8	Tube
FP5137D-LF	-10°C ~ +85°C	SOP8	Tube
FP5137DR-LF	-10°C ~ +85°C	SOP8	Tape & Reel

IC DATE CODE DISTINGUISH

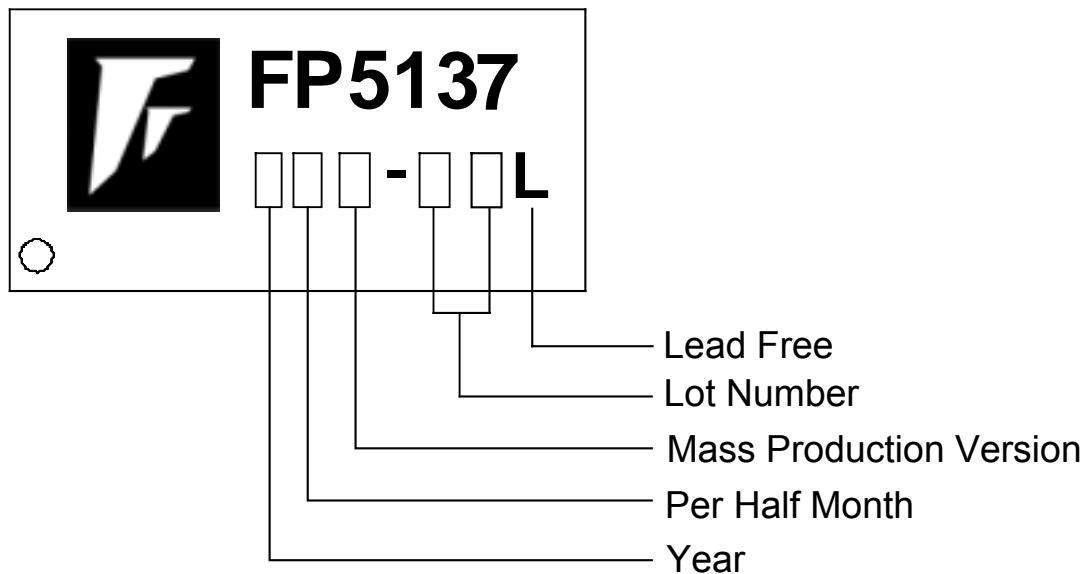

FOR EXAMPLE:

January A (Front Half Month), B (Last Half Month)
 February C, D
 March E, F -----And so on

Lot Number is the last two numbers

For Example:

A3311C62
 ↳ Lot Number

ABSOLUTE MAXIMUM RATINGS

Power supply voltage (V_{CC})	-----	+25V
Power supply voltage (V_C)	-----	+30V
Output source current	-----	-500mA
Output sink current	-----	+500mA
Allowable dissipation		
PDIP8 Ta +25	-----	800mW
SOP8 Ta +25	-----	650mW
Operating temperature	-----	-10°C +85°C
Storage temperature	-----	-55°C +125°C
Operating Junction Temperature Range	-----	+0°C 125°C
PDIP8 Lead Temperature (soldering, 20 sec)	-----	+260°C
SOP8 Lead Temperature (soldering, 10 sec)	-----	+260°C

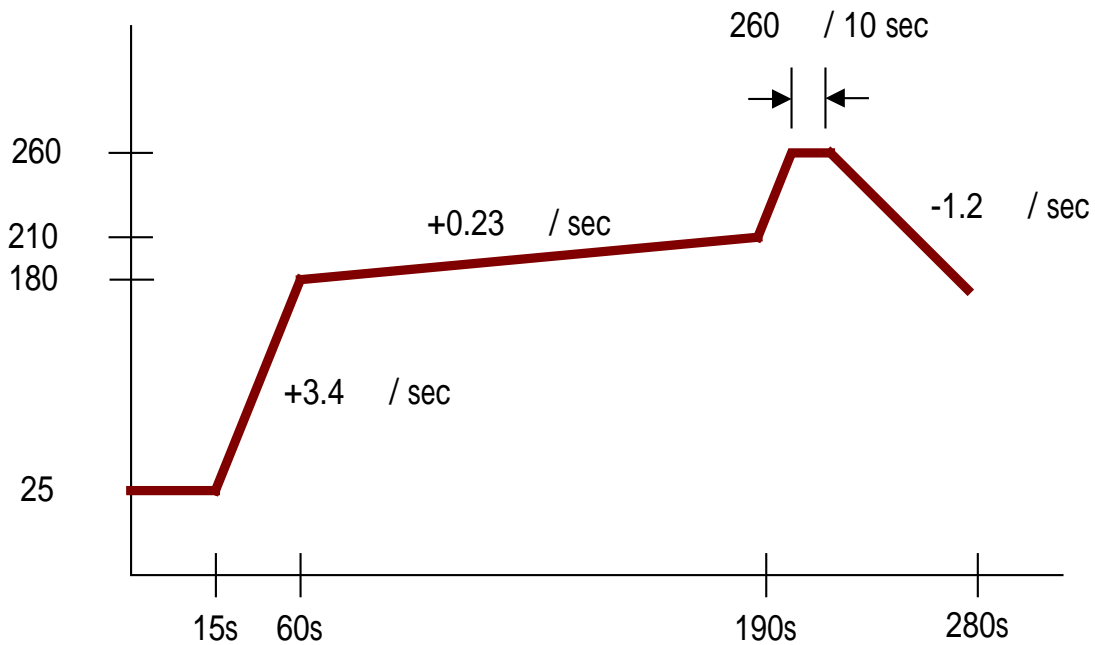

DC ELECTRICAL CHARACTERISTICS

Under Voltage Lock-Out section (U.V.L.O.)

PARAMETER	SYMBOL	TEST CONDITIONS	MIN	TYP	MAX	UNIT
UVLO threshold voltage	$V_{CC(UVLO)}$	Sweep up V_{CC}	4.0	4.2	4.4	V
Hysteresis voltage	$V_{CC(HYS)}$			0.25		V
UVLO threshold voltage	$V_C(UVLO)$	Sweep up V_C	3.1	3.3	3.5	V
Hysteresis voltage	$V_C(HYS)$			0.25		V
UVLO threshold voltage	$V_{FB(UVLO)}$	Sweep down FB	0.4	0.6	0.8	V
Hysteresis voltage	$V_{FB(HYS)}$			0.1		V

Soft Start section (S.S.)

PARAMETER	SYMBOL	TEST CONDITIONS	MIN	TYP	MAX	UNIT
Input source current	I_{SS}	$V_{SS} = 0V$	-10	-20	-30	μA

Oscillator section

PARAMETER	SYMBOL	TEST CONDITIONS	MIN	TYP	MAX	UNIT
Oscillation frequency	f		180	200	220	KHz
Frequency change with voltage	$\Delta f / \Delta V$	$V_{CC} = 5V$ to 25V		2	10	%
Frequency change with temperature	$\Delta f / \Delta T$	$T_a = -10$ to 85		5		%

Period Adjustment section

PARAMETER	SYMBOL	TEST CONDITIONS	MIN	TYP	MAX	UNIT
Maximum duty cycle	$T_{DUTY(ON)}$	$V_{FB} = 1.0V$	85	90	95	%
Minimum duty cycle	$T_{DUTY(OFF)}$	$V_{FB} = 1.5V$	0	0		%

DC ELECTRICAL CHARACTERISTICS (Cont.)

Total Device section

PARAMETER	SYMBOL	TEST CONDITIONS	MIN	TYP	MAX	UNIT
Dynamic V_{CC} supply current	$I_{CC(DYN)}$	$C_L=1500pF$	2	5	8	mA
Static V_{CC} supply current	I_{CCQ}	$V_{SS}=0V$	1	3.3	6	mA
Dynamic V_C supply current	$I_{C(DYN)}$	$C_L=1500pF$	2	7	10	mA
Static V_C supply current	I_{CQ}	$V_{SS}=0V$	0.5	1	4.5	mA

Error Amplifier section

PARAMETER	SYMBOL	TEST CONDITIONS	MIN	TYP	MAX	UNIT
Input threshold voltage	V_{FB}		1.225	1.25	1.275	V
V_{FB} change with voltage	$\Delta V_{FB} / \Delta V$	$V_{CC}=5V$ to 25V		5	20	mV
V_T change with temperature	$\Delta V_{FB} / \Delta T$	$T_a = -10$ to 85		1		%
Input bias current	I_{FB1}	$V_{SS}=3V, V_{FB}=1V$		-0.1		μA
	I_{FB2}	$V_{SS}=0V, V_{FB}=1V$		-64		μA
Transconductance	gm	--	450	600	750	μmho

Output section

PARAMETER	SYMBOL	TEST CONDITIONS	MIN	TYP	MAX	UNIT
HDrv output high voltage	V_{OH1}	$V_{FB}=0.9V, I_O=-200mA$		2		V
LDrv output high voltage	V_{OH2}	$V_{FB}=1.3V, I_O=-200mA$		2		V
HDrv output low voltage	V_{OL1}	$V_{FB}=1.3V, I_O=200mA$		1.8		V
LDrv output low voltage	V_{OL2}	$V_{FB}=0.9V, I_O=200mA$		1.8		V
Rise time	T_r	$C_L=1500pF$		50	100	ns
Fall time	T_f	$C_L=1500pF$		50	100	ns
Dead band time	T_{db}		50	100	150	ns

TYPICAL CHARACTERISTICS

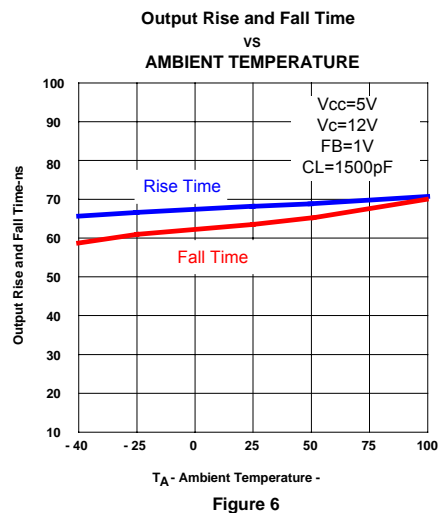
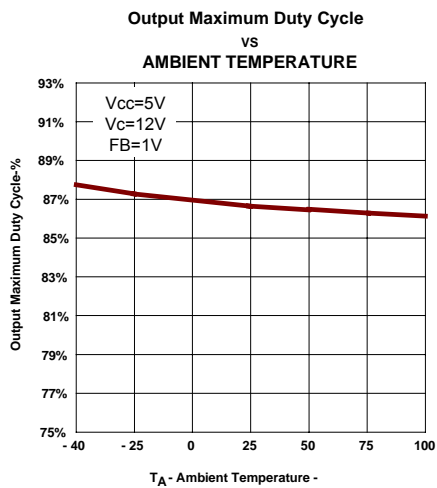
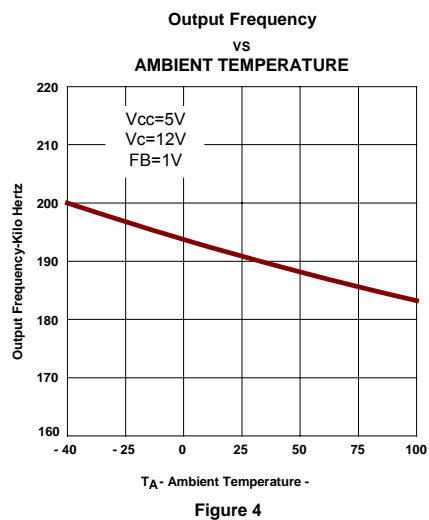
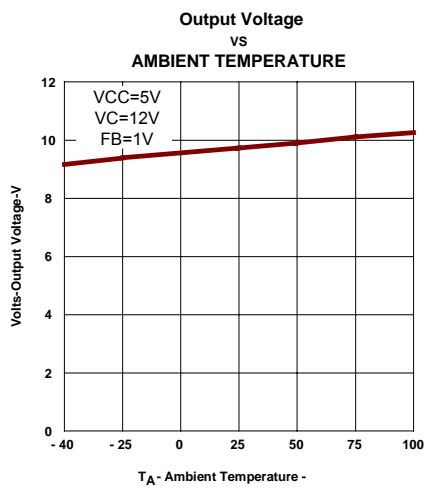
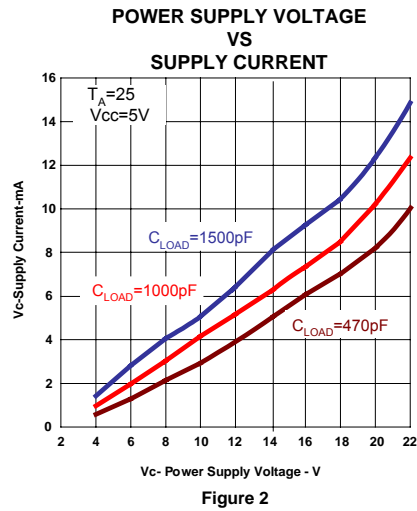
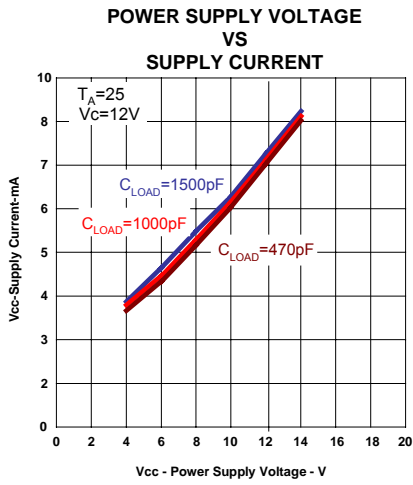

DETAILED DESCRIPTION

Voltage reference

A 3.0V regulator operating from VCC is used to power the internal circuitry of the **FP5137**. An internal resistive divider provides **1.25V** reference for the error amplifier, Soft-start (**typ. 1.5V**) and SCP (**typ. 0.5V**) circuits.

Error amplifier

The error amplifier compares a sample of the dc-dc converter output voltage to the **1.25V** reference and generates an error signal for the error comparator. Output voltage of dc-dc converter is setting with the resistor divider using the following expression (see figure 7):

$$V_{out} = \left(1 + \frac{R1}{R2}\right) * 1.25$$

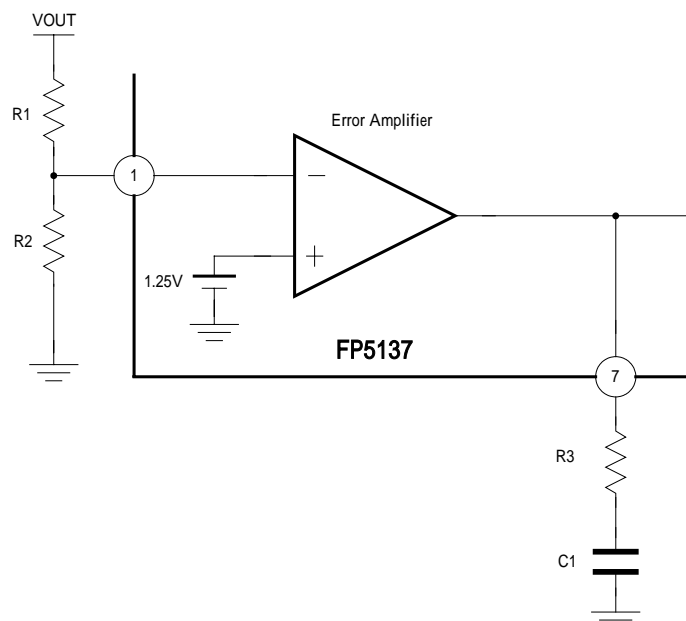

Figure 7. Error Amplifier with Feedback resistance divider

Oscillator

The fixed frequency generates from an internal RC oscillator, and the typical value is **200KHz**.

Under voltage lockout (UVLO)

FP5137 has a different under voltage lockout point for VCC (**typ. 4.2V**) and VC (**typ. 3.3V**).

The converter is normal operation when supply voltage rises above the point of lockout; otherwise the output drivers of **FP5137** are off.

Soft Start

When the VCC and VC of **FP5137** are ready, the power on reset (POR) signal is enable. The internal current source (**typ. 20 μ A**) will charge the external capacitor connected soft-start pin and another internal current source (**max. 64 μ A**) will control feedback voltage of error amplifier and enable output driver for soft-start function. The soft-start timing can be decided by following expression:

$$t_{ss} = 75 * C_{ss}(ms)$$

FP5137 should be shutdown whenever it is forced a voltage under **0.5V** at soft-start pin.

Short-circuit protection

FP5137 should be shutdown immediately whenever output voltage under **0.6V**, the mean is hard to maintain the output voltage during maximum duty cycle under short-circuit, and the PWM output are off until short circuit problem is release.

Output transistor and boost voltage V_C

FP5137 uses two NMOS and their turn-on VGS voltage near 4.5V, the source voltage of high side NMOS is near VIN, and it is necessary to supply a boost voltage higher than VIN for high side NMOS gate drive, the following figure explains the relation of MOS gate to source voltage. Application circuits can use different method to solve the boost power supply VC for high side driver. (**Recommend boost voltage VC is sum of VIN and VGS**)

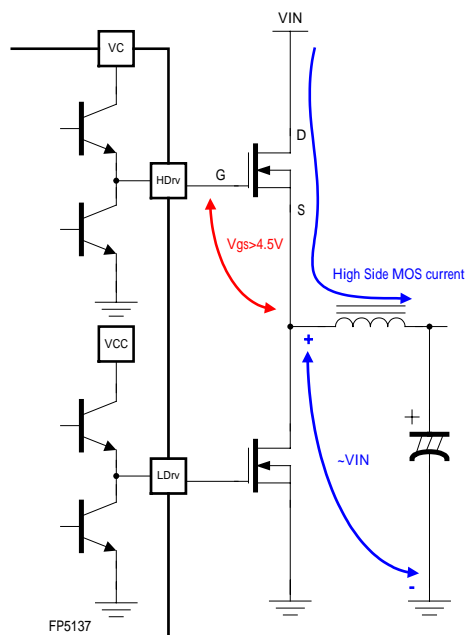

Figure 8. IC Output Stage with NMOS

BASIC APPLICATION NOTE (Dual Power Supply)

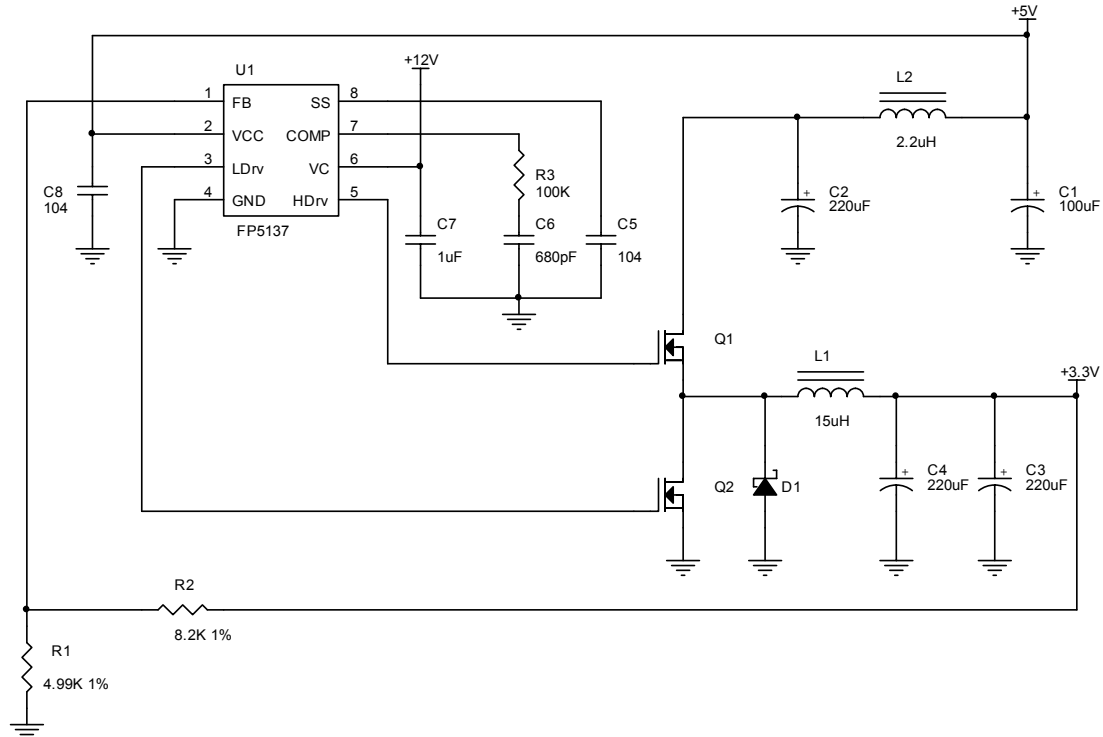

Figure 9. FP5137 DC/DC Converter circuit using dual power supply

Application Description

This is a simple application circuit using dual power supply (+5V and +12V), the converting voltage is from +5V to +3.3V, and +12V connects with VC pin makes sure the high side NMOS can be turn-on.

The output voltage determines from the following formula:

$$V_{out} = \left(1 + \frac{R2}{R1}\right) * V_{REF} = \left(1 + \frac{8.2K}{4.99K}\right) * 1.25 = 3.30V$$

The soft-start time determines from the following formula:

$$T_{ss} = 75 * C5 = 75 * 0.1(ms) = 7.5ms$$

BASIC APPLICATION NOTE (Single Power Supply)

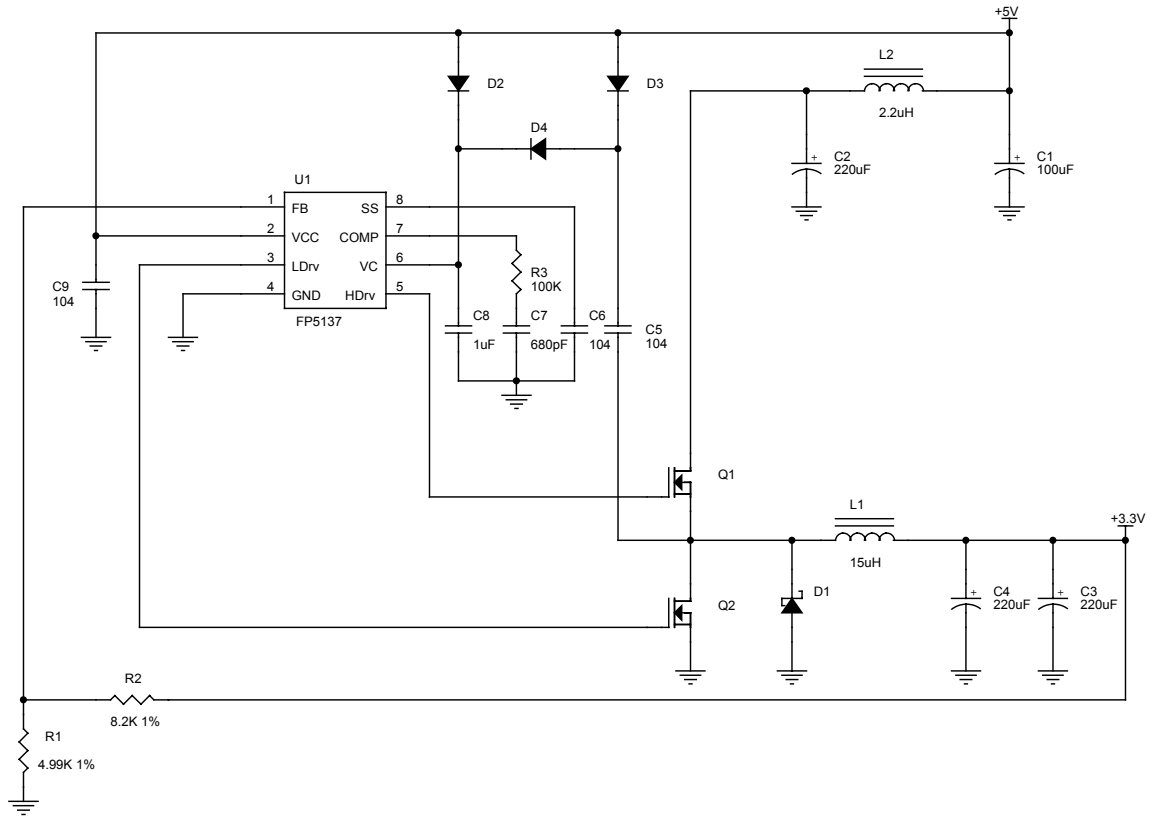

Figure 10. FP5137 DC/DC Converter circuit using single power supply

Application Description

This application circuit is same as dual power supply but VC pin uses a charge-pump circuit with D2~D4 and C5, C8.

The C5 capacitor would charge near +5V through D3 when +5V power supply is turn-on, the voltage of VC is a sum of C5 voltage and $V_{IN}-V_{DIODE}$ voltage, is higher than Q1 source terminal during Q1 turns on.

PACKAGE OUTLINE SOP8

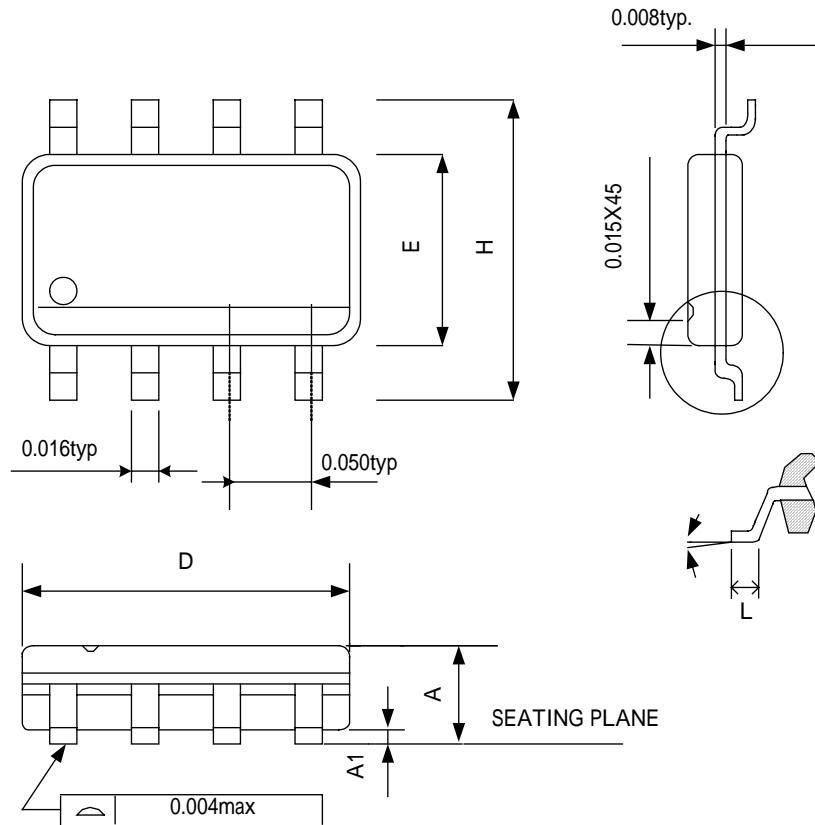

SYMBOLS	MIN	MAX
A	0.053	0.069
A1	0.004	0.010
D	0.189	0.196
E	0.150	0.157
H	0.228	0.244
L	0.016	0.050
θ°	0	8

NOTE:

- JEDEC OUTLINE:MS-012 AA
- DIMENSIONS "D" DOES NOT INCLUDE MOLD FLASH,PROTRUSIONS OR GATE BURRS.MOLD FLASH,PROTRUSIONS AND GATE BURRS SHALL NOT EXCEED .15mm (.06in) PER SIDE
- DIMENSIONS "E" DOES NOT INCLUDE INTER-LEAD FLASH,OR PROTRUSIONS. INTER-LEAD FLASH AND PROTRUSIONS SHALL NOT EXCEED .25mm (.0.10in) PER SIDE.

PDIP 8

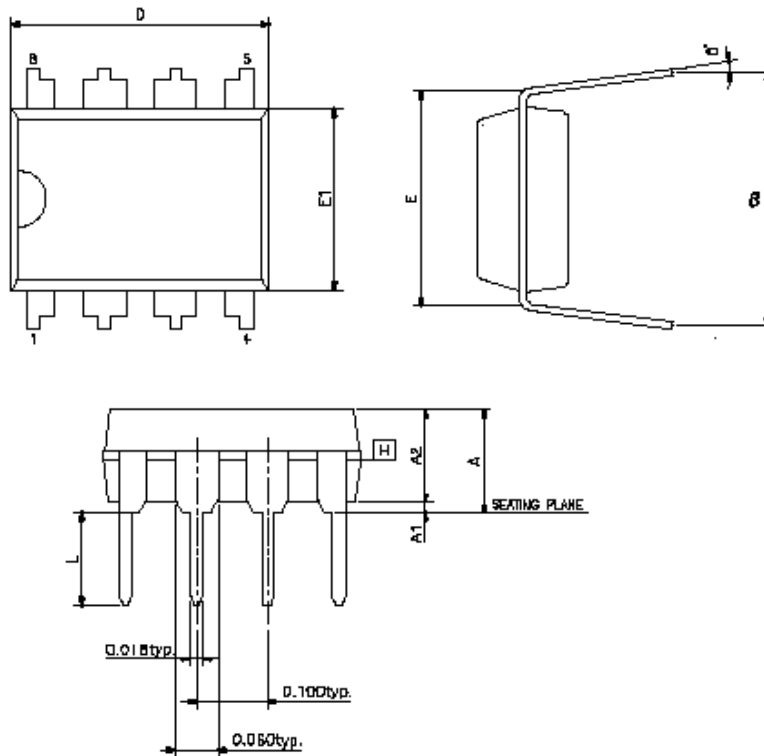

SYMBOLS	MIN	NOR	MAX
A	-	-	0.210
A1	0.015	-	-
A2	0.125	0.130	0.135
D	0.355	0.365	0.400
E	0.300BSC		
E1	0.245	0.250	0.255
L	0.115	0.130	0.150
e θ	0.335	0.355	0.375
θ°	0	7	15

NOTE:

0. JEDEC OUTLINE: MS-001 BA

1. "D" "E1" DIMENSIONS DO NOT INCLUDE MOLD FLASH OR PROTRUSIONS SHALL NOT EXCEED .010 INCH

2. eB IS MEASURED AT THE LEAD TIPS WITH THE LEADS UNCONSTRAINED

3. POINTED OR ROUNDED LEAD TIPS ARE PREFERRED TO EASE INSERTION

4. DISTANCE BETWEEN LEADS INCLUDING DAM BAR PROTRUSIONS TO BE .005 INCH MINIMUM

5. DATUM PLANE H COINCIDENT WITH THE BOTTOM OF LEAD, WHERE LEAD EXITS BODY.

PACKING SPECIFICATIONS

BOX DIMENSION

TUBE INSIDE BOX AND CARTON

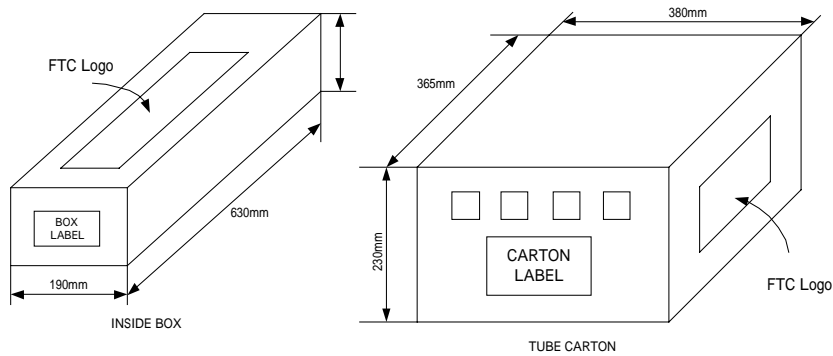

TAPE AND REEL INSIDE BOX AND CARTON

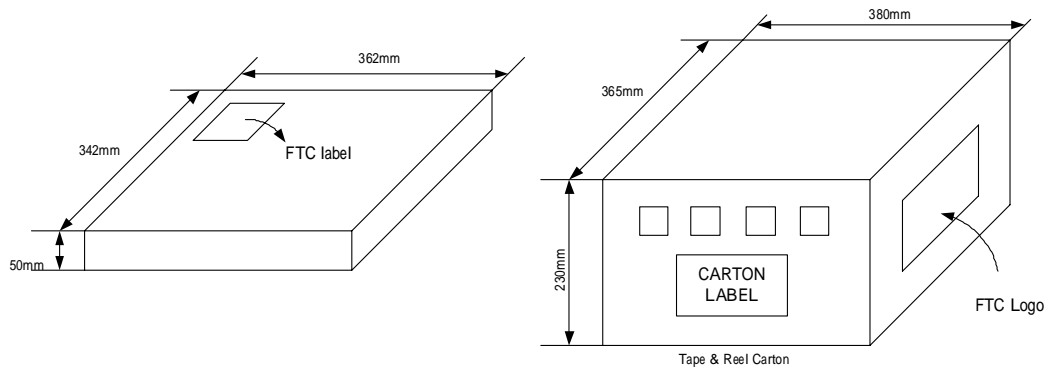

PACKING QUANTITY SPECIFICATIONS

SOP8	PDIP8	SOP8
100 EA/TUBE	50 EA/TUBE	2500 EA / REEL
100 TUBES / INSIDE BOX		4 INSIDE BOXES / CARTON
4 INSIDE BOXES / CARTON		

LABEL SPECIFICATIONS

Tapping & Reel

Feeling Technology Corp.
Product FP5137
Lot No A3311C62
D/C 4Xx-XXL
Q'ty
<div style="border: 1px solid black; padding: 2px; display: inline-block;"> 無鉛 Lead Free </div>

CARTON

Feeling Technology Corp.	
Product Type: FP5137	
Lot No: A3311C62	
Date Code: 4Xx-XXL	
Package Type: SOP-8L	
Marking Type: Laser	無鉛 Lead Free
Total Q'ty: 10,000	

CARRIER TAPE DIMENSIONS

APPLICATION	W	P	E	F	D	D ₁
SOP8	12.0 ^{+0.3} _{-0.1}	8.0±0.1	1.75±0.1	5.5±0.1	1.55±0.1	1.5 ^{+0.25}

APPLICATION	P ₀	P ₁	A _D	B ₀	K ₀	t
SOP8	4.0±0.1	2.0±0.1	6.4±0.1	5.20±0.1	2.1±0.10	0.30±0.013

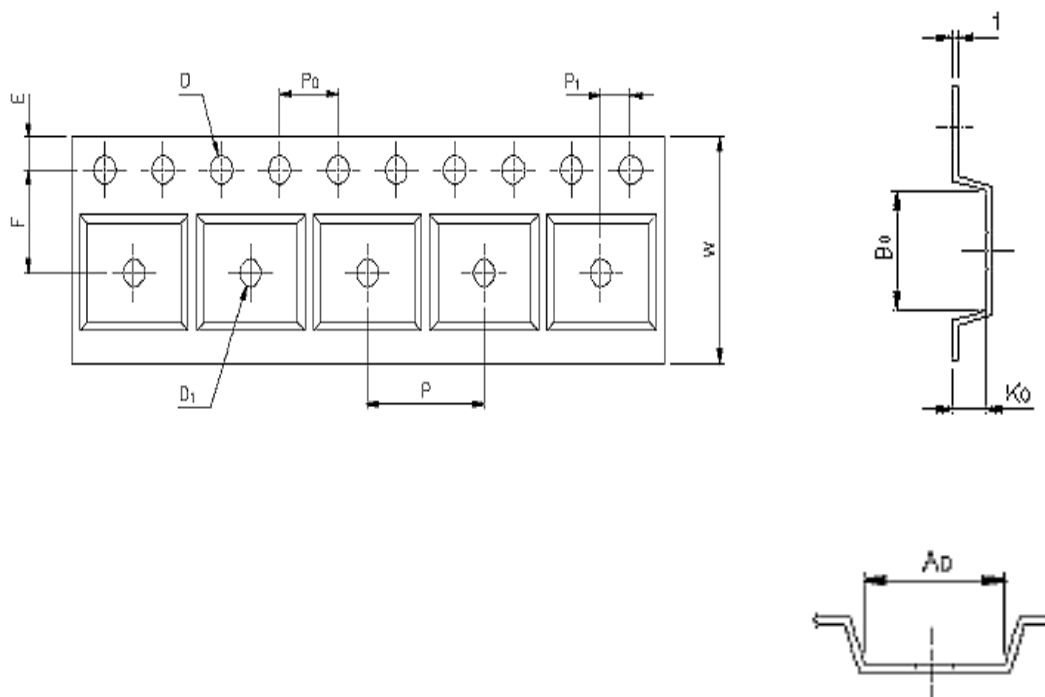

REEL DIMENSIONS

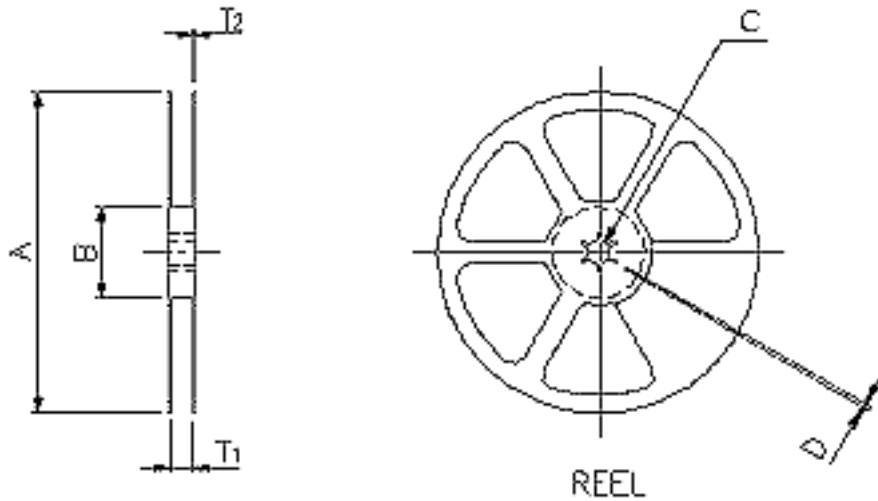

APPLICATION	MATERIAL	A	B	C	D	T ₁	T ₂
SOP8	PLASTIC REEL (WHILE)	330±0.1	62±1.5	12.75+0.15	2+0.6	12.4+0.2	2.0+0.2