

Features

- LED Power Efficiency: up to 90%
- Internal 2A MOSFET Switch
- 1.0MHz Switching Frequency
- Uses Small, Low Profile External Components
- Low Start-Up Voltage: 0.9V
- Low $R_{DS(ON)}$: 100m Ω (TYP.)
- Open LED Protection
- Over Temperature Protection
- Low Profile SOT-23 Package
- Pb-Free Package

Applications

- White LED Torch (Flashlight)
- White LED Camera Flash
- DSC(Digital Still Camera)Flash
- Cellular Camera Phone Flash
- PDA Camera Flash
- Camcorder Torch(Flashlight) Lamp

General Description

The PAM2801 is a step-up DC-DC converter that delivers a regulated output current. The device switches at a 1.0MHz constant frequency, allowing for the use of small value external inductor and ceramic capacitors.

The PAM2801 is targeted to be used for driving 1W white LED from a 0.9V to 3.2V input. The LED current can be programmed by the external current sense resistor, R_s , connected between the feedback pin (FB) and ground. A low 95mV feedback voltage reduces the power loss in the R_s for better efficiency. With its internal 2A, 100m Ω NMOS switch, the device can provide high efficiency even at heavy load.

LED dimming can be done by using a DC voltage applied to the FB pin and a pulse width modulation (PWM) signal applied to the FB pin or SHDN pin. During the shutdown mode, the feedback resistor R_s and the load are completely disconnected and the current consumption is reduced to less than 1uA.

The PAM2801 is available in the 6-lead SOT-23-6 package.

Typical Application

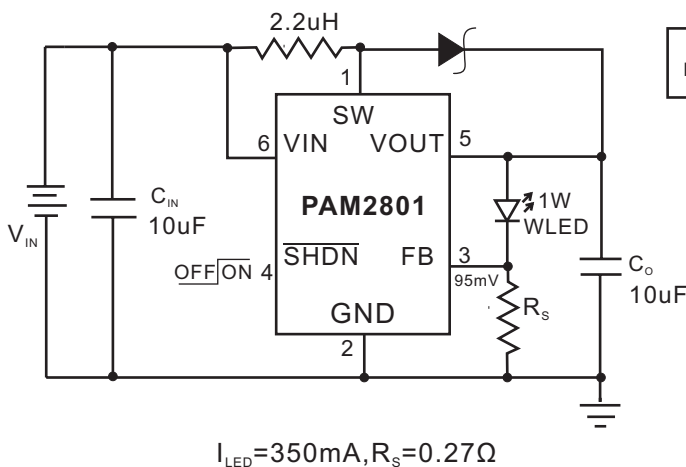

Block Diagram

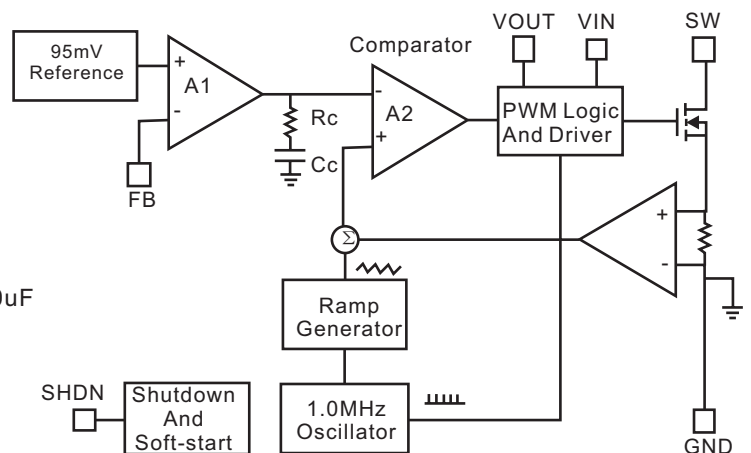

Pin Configuration & Marking Information

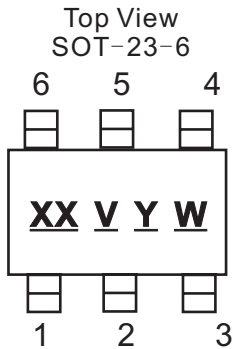

XX: Product Code
 V: Voltage Code
 Y: Year
 W: Weekly

Pin Number	Name	Function
1	SW	Switch
2	GND	Ground
3	FB	Feedback
4	SHDN	Shut Down
5	VOUT	Output
6	VIN	Input

Absolute Maximum Ratings

These are stress ratings only and functional operation is not implied. Exposure to absolute maximum ratings for prolonged time periods may affect device reliability. All voltages are with respect to ground.

Input Pin Voltage.....	-0.3V to 6V	Operating Temperature Range	-40°C to 85°C
SW Pin Voltage.....	-0.3V to 6V	Storage Temperature Range.....	-65°C to 125°C
SHDN, FB Pin Voltage.....	-0.3V to 6V	Lead Temperature (Soldering, 5 sec)	300°C

Recommended Operating Conditions

Junction Temperature.....	-40°C to 125°C	Ambient Temperature.....	-40°C to 85°C
---------------------------	----------------	--------------------------	---------------

Thermal Information

Parameter	Package	Symbol	Maximum	Unit
Thermal Resistance (Junction to Case)	SOT-23-6	θ_{JC}	130	°C/W
Thermal Resistance (Junction to Ambient)	SOT-23-6	θ_{JA}	250	
Internal Power Dissipation	SOT-23-6	P_D	400	mW



Electrical Characteristic

$T_A=25^{\circ}\text{C}$, $V_{IN}=2.4\text{V}$, $I_{LED}=350\text{mA}$, $V_{SHDN}=V_{IN}$, $L=2.2\mu\text{H}$, $C_{IN}=10\mu\text{F}$, $C_O=10\mu\text{F}$, unless otherwise noted.

Parameter	Symbol	Conditions	Min	Typ	Max	Unit
Input Voltage Range	V_{IN}		0.9		$V_F-0.2$ (note 1)	V
Feedback Voltage	V_{FB}		90	95	100	mV
Oscillator Frequency	F_{OSC}		0.85	1.0	1.15	MHz
SHDN Input High	V_{SH}	$V_{IN}=1.8\text{V}$	1.0			V
SHDN Input Low	V_{SL}	$V_{IN}=1.8\text{V}$			0.4	V
Over Temperature Shutdown	OTS			150		$^{\circ}\text{C}$
Over Temperature Hysteresis	OTH			15		$^{\circ}\text{C}$
Maximum Output Current Range	$I_{O(MAX)}$		350			mA
Quiescent Current	I_Q	$I_{LED}=0\text{mA}$, $V_O=3.4\text{V}$, Device Switching at 1MHz		1	3	mA
Shutdown Current	I_{SD}	Shutdown mode			1	μA
Switch on Resistance	R_{DSON}	$V_O=3.4\text{V}$		0.1		Ω
Current Limit	I_{LIM}	$V_O=3.4\text{V}$	2			A

Note1: V_F - LED Forward Voltage

Typical Performance Characteristics

$T_A=25^\circ\text{C}$, $L=2.2\mu\text{H}$, $C_{IN}=10\mu\text{F}$, $C_O=10\mu\text{F}$, unless otherwise noted.

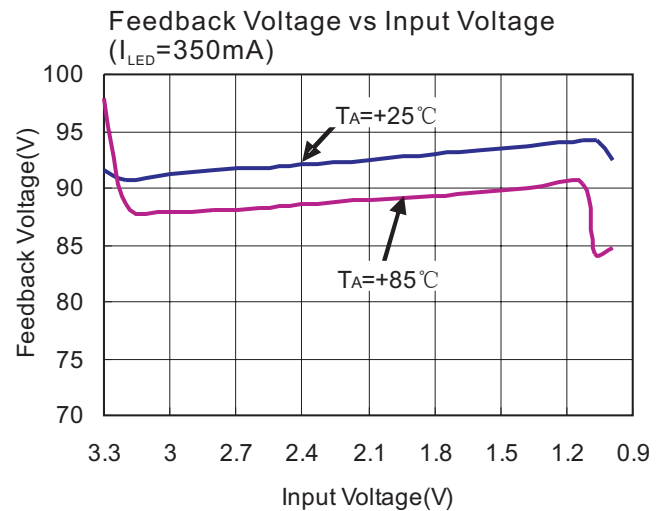
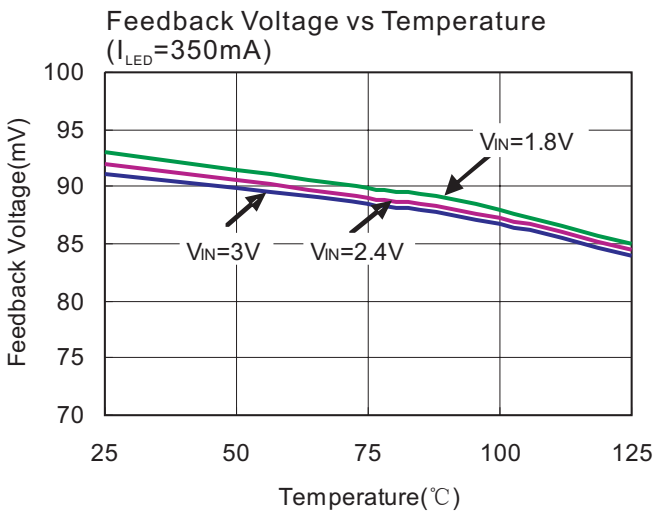
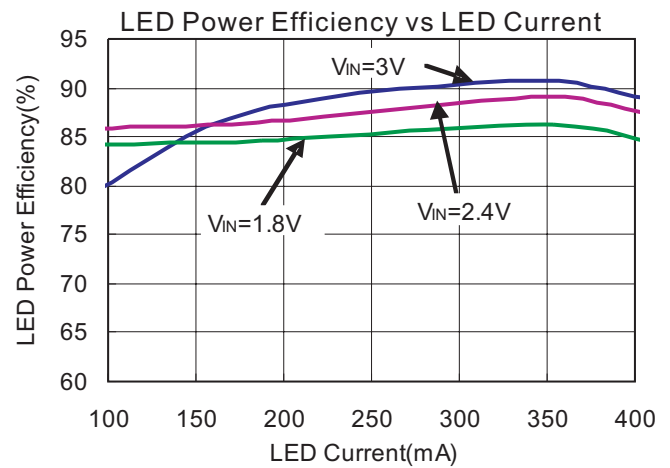
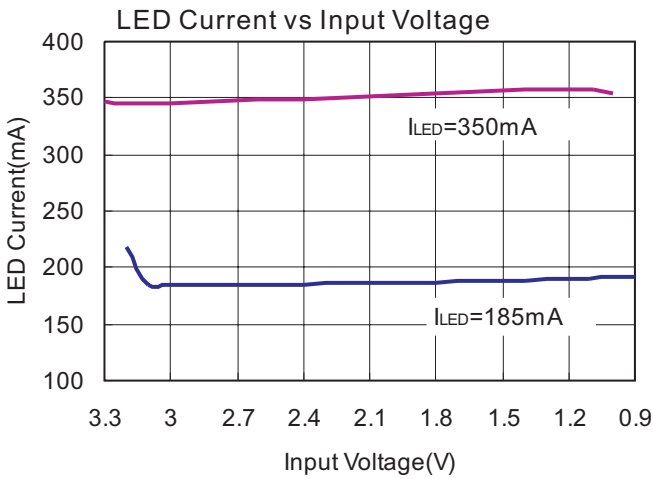
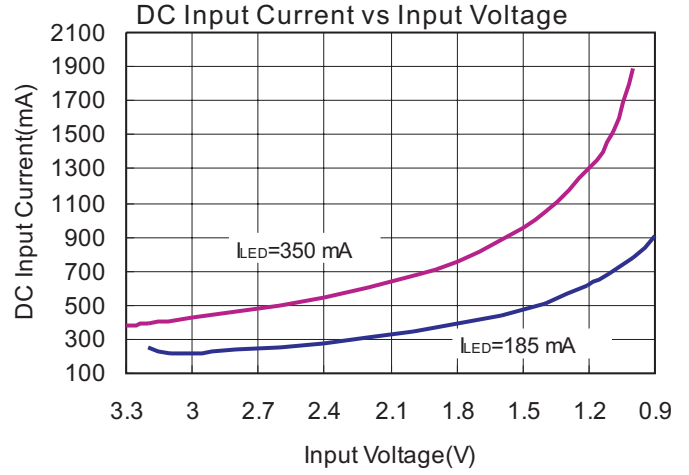
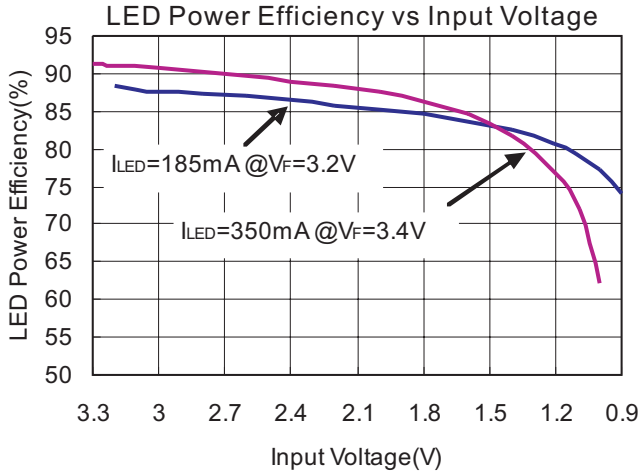

Typical Performance Characteristics (continued)

Switching Waveform

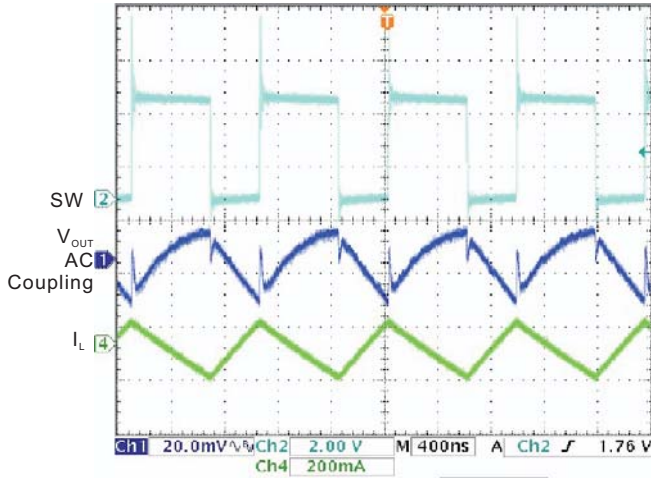

Start-Up Waveform

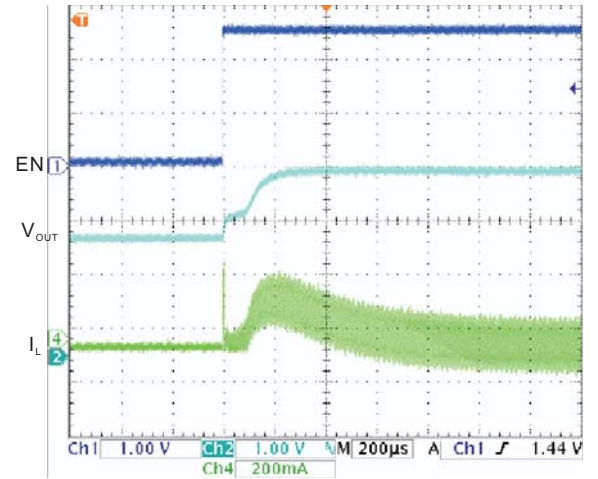

Overvoltage Protection

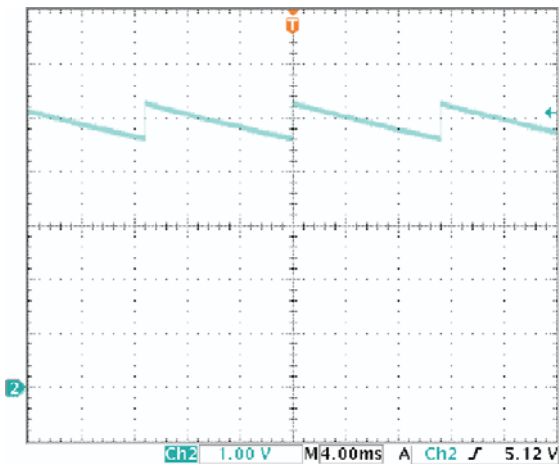

Application Information

Inductor Selection

The PAM2801 can use a small value inductor due to its switching frequency of 1MHz. The value of inductor focuses in the range of 1.5uH to 4.7uH for most PAM2801 applications. In typical high current white LED applications, it is recommended to use a 4.7uH inductor. The inductor should have low DCR (DC resistance) to minimize the I^2R power loss, and it requires a current rating of 2A to handle the peak inductor current without saturating.

Capacitor Selection

An input capacitor is required to reduce the input ripple and noise for proper operation of the PAM2801. For good input decoupling, Low ESR (equivalent series resistance) capacitors should be used at the input. At least 2.2uF input capacitor is recommended for most applications.

A minimum output capacitor value of 4.7uF is recommended under normal operating conditions, while a 10uF-22uF capacitor may be required for higher power LED current. A reasonable value of the output capacitor depends on the LED current. The ESR of the output capacitor is the important parameter to determine the output voltage ripple of the converter, so low ESR capacitors should be used at the output to reduce the output voltage ripple. The small size of ceramic capacitors is an excellent choice for PAM2801 applications. The X5R and X7R types are preferred because they maintain capacitance over wide voltage and temperature ranges.

Diode Selection

It's indispensable to use a Schottky diode rated at 2A with the PAM2801. Using a Schottky diode with a lower forward voltage drop is better to improve the power LED efficiency, and its voltage rating should be greater than the output voltage. In application, the ON Semiconductor MBRA210LT3G is recommended.

LED Current Setting

The LED current is set by the single external R_s resistor connected to the FB pin as shown in the typical application circuit on page 1. The typical

FB reference is internally regulated to 95mV. The LED current is $95mV/R_s$. It's recommended to use a 1% or better precision resistor for the better LED current accuracy. The formula and table 1 for R_s selection are shown as follows:

$$R_s = 95mV / I_{LED}$$

Table 1. R_s Resistor Value Selection

$I_{LED}(mA)$	$R_s(\Omega)$
200	0.475
300	0.317
350	0.270
400	0.238

LED Dimming Control

Dimming Control Using a DC Voltage to FB Pin

One method for dimming the LEDs is to apply a variable DC voltage through a resistor to the FB pin of the PAM2801. The dimming control with a DC voltage is shown in the Figure1. The DC voltage artificially raises the FB pin voltage, with the DC voltage increasing, the voltage across R_2 increases and the voltage R_s decreases, which therefore lowers the LED current. The values of resistor R_1 and R_2 should be large enough to make the current from the DC source much smaller than the LED current while much larger than the FB leakage current. When V_{DC} ranges from 0V to 2V, the resistors in the Figure will set the LED current from 0mA to 350mA.

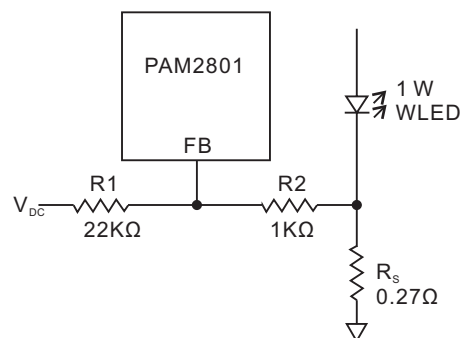

Figure 1. Dimming Control Using a DC Voltage to FB Pin

Application Information (continued)

Dimming Control Using a PWM Signal to FB Pin

By using the PWM signal to FB pin as shown in the Figure 2, the LED turns on or off and its current operates at either 0mA or the set maximum current. The PWM signal can be considered as an adjustable DC voltage. As the PWM duty cycle increases, the LED current decreases. Typically, the PWM frequency ranges from 5KHz to 40KHz.

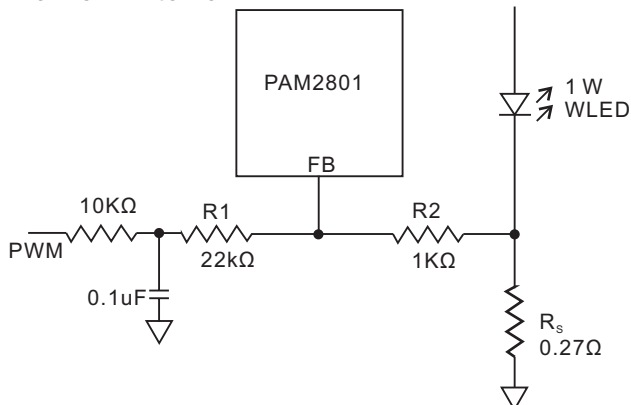
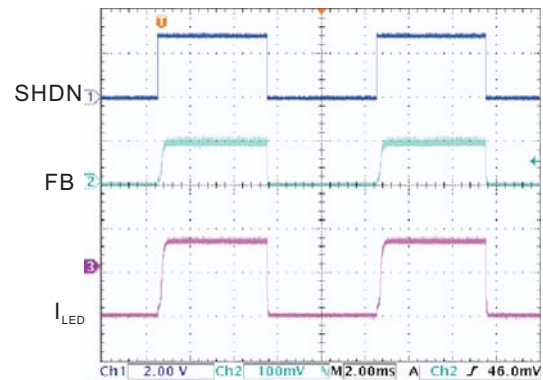

Figure 2. Dimming Control Using a PWM Signal to FB Pin

Dimming Control Using a PWM Signal to SHDN Pin

With the PWM signal applied to the SHDN pin of the PAM2801, the LED turns on or off. When the SHDN pin is high, the LED turn on and its current is at the set maximum current; when the SHDN pin is low, the LED turn off and its current turns to 0mA. The average LED current increase proportionally with the PWM duty cycle. A 0% duty cycle produces 0mA of LED current; a 100% duty cycle corresponds to the set maximum current. The magnitude of the PWM signal should be higher than the SHDN input high (V_{SH}). The typical frequency of the PWM signal ranges from 100Hz to 1KHz. Figure 3 shows the LED current with the PWM duty cycle set to 50% and the PWM frequency set respectively to 100Hz and 1KHz. Figure 4 shows the LED current versus the PWM duty cycle, setting the PWM frequency to 100Hz.



(3a) 100Hz

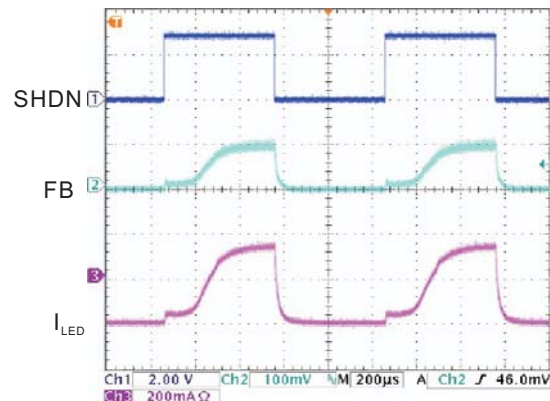

(3b) 1 KHz

Figure 3. Dimming Control Using a PWM Signal to SHDN Pin

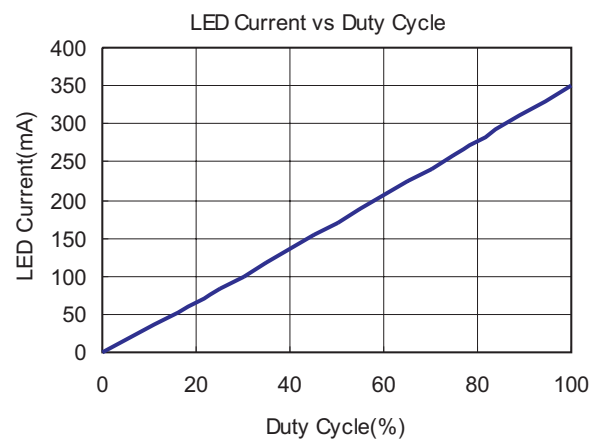

Figure 4. LED Current vs Duty Cycle

Application Information (continued)

PCB Layout Guidelines

As for all switching power supplies, the layout and components placement of the PAM2801 is an important step in the design; especially at high peak currents and high switching frequencies.

The input capacitor and output capacitor should be placed respectively as close as possible to

the input pin and output pin of the IC; the inductor and schottky diode should be placed as close as possible to the switch pin by using wide and short traces for the main current path; the current sense resistor should be placed as close as possible between the ground pin and feedback pin.

Ordering Information

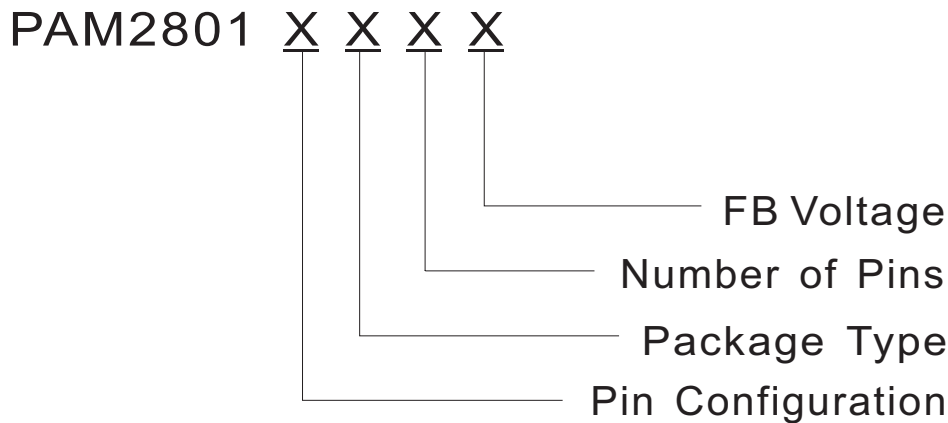

Pin Configuration	Package Type	Number of Pins	FB Voltage
A Type 1. SW 2. GND 3. FB 4. SHDN 5. VOUT 6. VIN	A: SOT-23-6	C: 6	095: 95mV

Part Number	Marking	Package Type	Standard Package
PAM2801AAC095	CDAYW	SOT-23-6	3,000Units/Tape&Reel

Please consult PAM sales office or authorized Rep./Distributor for detailed ordering information.

Outline Dimension

SOT-23-6

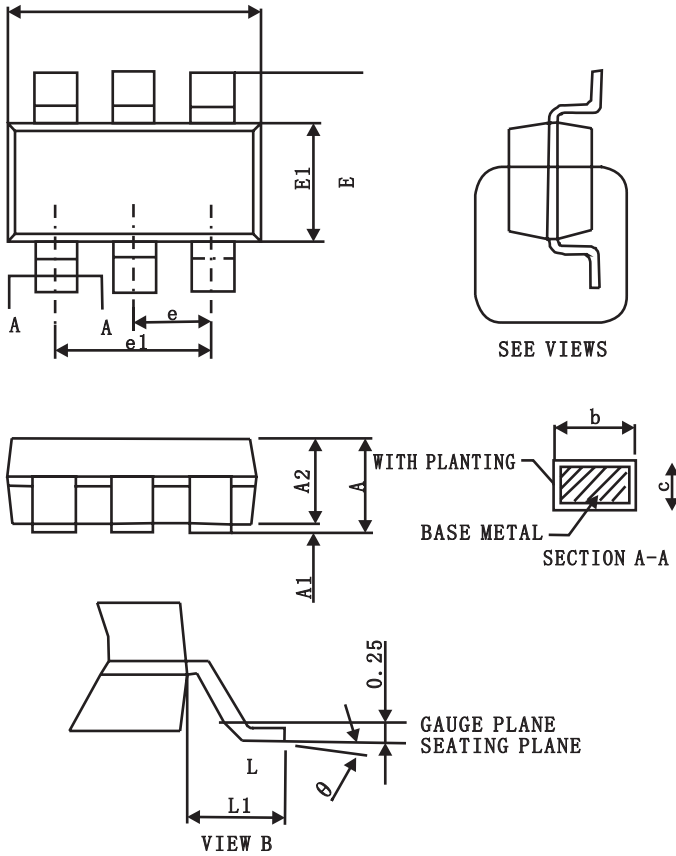

Symbol	A	A1	A2	b	c	D	E
Spec	1.20±0.25	0.10±0.05	1.10±0.2	0.40±0.1	0.15±0.07	2.90±0.1	2.80±0.2
Symbol	E11	e	e 1	L	L1	θ	
Spec	1.60±0.1	0.95BSC	1.90BSC	0.55±0.25	0.60REF	4°±4°	