

## GENERAL DESCRIPTION

The PT1301 is a compact, high efficiency, and low voltage step-up DC/DC converter with an Adaptive Current Mode PWM control loop. It comprises of an error amplifier, a ramp generator, a PWM comparator, a switch pass element and the driver. It provides stable and high efficient operation over a wide range of load currents without external compensation. The below 1V start-up input voltage makes PT1301 suitable for single battery cell applications. The built-in power transistor is able to provide up to 300mA output current while working under Li-Battery Supply. Besides, it provides extra pin to drive external power devices (NMOS or NPN ) in case higher output current is needed. The output voltage is set with two external resistors. The 500KHz high switching rate reduces the size of external components. Besides, the 14µA low quiescent current together with high efficiency maintains long battery lifetime..

## FEATURES

- ◆ Low Quiescent (Switch-off) Supply Current: 14µA
- ◆ Low Start-up Input Voltage: typical 0.8V
- ◆ High Supply Capability: Deliver 3.3V 100mA with 1Alkaline Cell; 5V 300mA with 1 Li-Cell
- ◆ Zero Shutdown Mode Supply Current
- ◆ High efficiency: 90%
- ◆ Fixed switching frequency: 500KHz
- ◆ Options for internal or external power switches
- ◆ Package type: SOT-26, SOT-89-5

## APPLICATION

MP3, PDA, Electronic Dictionary, DSC, LCD, RF-Tag, Portable Devices, Wireless Devices, etc.

## PIN ASSIGNMENT

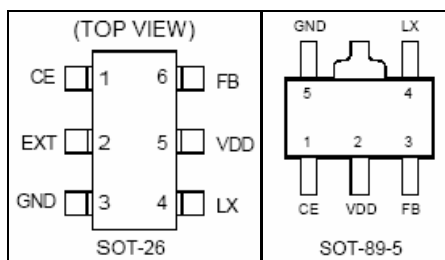

## PIN DESCRIPTION

Pin No		Symbol	Description
SOT-26	SOT-89-5		
1	1	CE	Enable pin. PT1301 Shut-down when CE is low
2		EXT	Output pin for driving external power transistor
3	5	GND	Ground
4	4	LX	Output for internal power switch
5	2	VDD	Power Supply
6	3	FB	Feed back input

## ORDERING INFORMATION

### PT1301CPPP

Package Type

26F: SOT-26

89E: SOT-89-5

Fixed to Letter E

## ABSOLUTE MAXIMUM RATINGS

Symbol	Item	Rating	Unit
V <sub>DD</sub>	Supply Voltage	-0.3~7.0V	V
V <sub>LX</sub>	LX pin Switch Voltage	-0.3~7.0V	V
V <sub>IO</sub>	Voltage on other I/O pins	-0.3V to (V <sub>DD</sub> +0.3V)	
I <sub>OUT</sub>	LX pin Output Current	2.5	A
I <sub>EXT</sub>	EXT pin Drive Current	200	mA
PTR1	Package Thermal Resistance SOT-26, $\Theta_{JC}$	145	W/°C
PTR2	Package Thermal Resistance SOT-89-5, $\Theta_{JC}$	45	W/°C
Topt	Operating Temperature Range	-40~125	°C
Tstg	Storage Temperature Range	-65~150	°C
Tsolder	Lead Temperature (Soldering)	260°C, 10s	

Note: Absolute Maximum Ratings are threshold limit values that must not be exceeded even for an instant under any condition. Moreover, such values for any two items must not be reached simultaneously. Operation above these absolute maximum ratings may cause degradation or permanent damage to the device. These are stress ratings only and do not necessarily imply functional operation below these limits.

## ELECTRICAL CHARACTERISTICS

(V<sub>IN</sub>=1.5V, V<sub>DD</sub>=3.3V, load current=0, TA =25°C, unless otherwise specified. )

Symbol	Item	Test Condition	Min	Typ	Max	Unit
V <sub>ST</sub>	Startup Voltage	IL = 1mA	--	0.80	1.05	V
V <sub>DD</sub>	Operating V <sub>DD</sub> Range	VDD pin Voltage	2	--	6	V
I <sub>OFF</sub>	Shutdown Current I (V <sub>IN</sub> )	V <sub>CE</sub> = 0V, V <sub>IN</sub> = 4.5V	--	0.01	1	μA
I <sub>SWITCH OFF</sub>	Switch-Off Current I(V <sub>DD</sub> )	V <sub>IN</sub> = 6V	--	14	25	μA
I <sub>SWITCH</sub>	Continuous Switching Current	V <sub>IN</sub> = V <sub>CE</sub> = 3.3V, V <sub>FB</sub> = GND	0.22	0.24	0.7	mA
I <sub>NO LOAD</sub>	No Load Current I(V <sub>IN</sub> )	V <sub>IN</sub> = 1.5V, V <sub>OUT</sub> = 3.3V	--	56	--	μA
V <sub>REF</sub>	Feedback Reference Voltage	Close loop, V <sub>DD</sub> = 3.3V	1.225	1.25	1.275	V
F <sub>S</sub>	Switching Frequency	V <sub>DD</sub> = 3.3V	425	500	575	KHz
D <sub>MAX</sub>	Maximum Duty	V <sub>DD</sub> = 3.3V	85	94	--	%
	On Resistance, LX to VDD	V <sub>DD</sub> = 3.3V	--	0.3	1.1	Ω
I <sub>LIMIT</sub>	Limit Current	V <sub>DD</sub> = 3.3V	1	1.5	2	A
	On Resistance, EXT to VDD	V <sub>DD</sub> = 3.3V	--	4.4	8.5	Ω
	On Resistance, EXT to GND	V <sub>DD</sub> = 3.3V	--	2.45	8.5	Ω
ΔV <sub>LINE</sub>	Line Regulation	V <sub>IN</sub> = 3.5 ~ 6V, IL = 1mA	--	1.25	5	mV/V
ΔV <sub>LOAD</sub>	Load Regulation	V <sub>IN</sub> = 2.5V, IL = 1 ~ 100mA	--	0.14	--	mV/mA
	CE trigger Level	V <sub>DD</sub> = 3.3V	0.4	0.8	1.2	V
TS	Vout Temperature Coefficient			50		ppm/°C
ΔTSD	Thermal Shutdown Hysterises		--	10	--	°C

## TYPICAL APPLICATION CIRCUITS

### (1) Typical Application

1.5V in, 3.3V out, 100mA Output Current

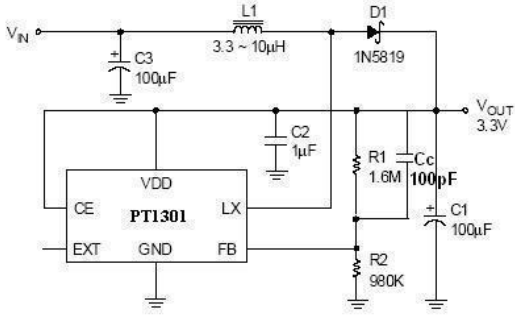

PT1301 Typical Application

Note: Cc for better Stability

### (2) Extending Output Current

1.5V in, 3.3V out, 250mA Output Current

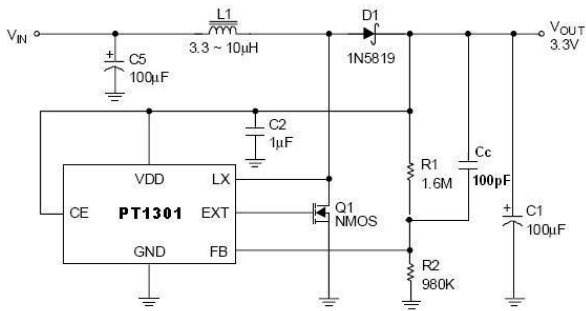

Extending Output Current

Note: Cc for better Stability

### (3) 300mA Output Current without External MOSFET

2V in, 3.3V out, 300mA Output Current

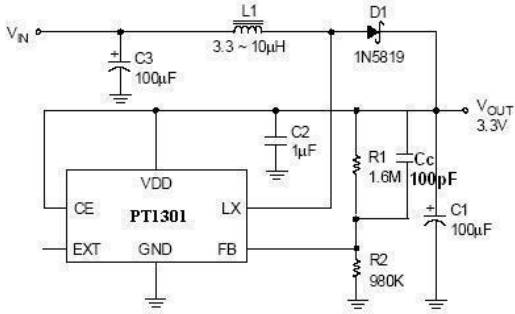

PT1301 Typical Application

Note: Cc for better Stability

### (4) High Output Voltage

5V in, 12V out, 300mA Output Current

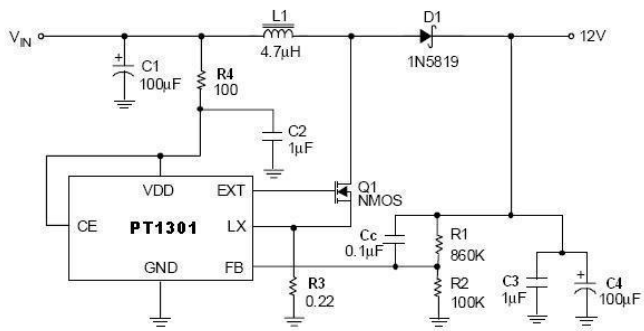

PT1301 High V Large I Output

Note: Cc for better Stability

## BLOCK DIAGRAM

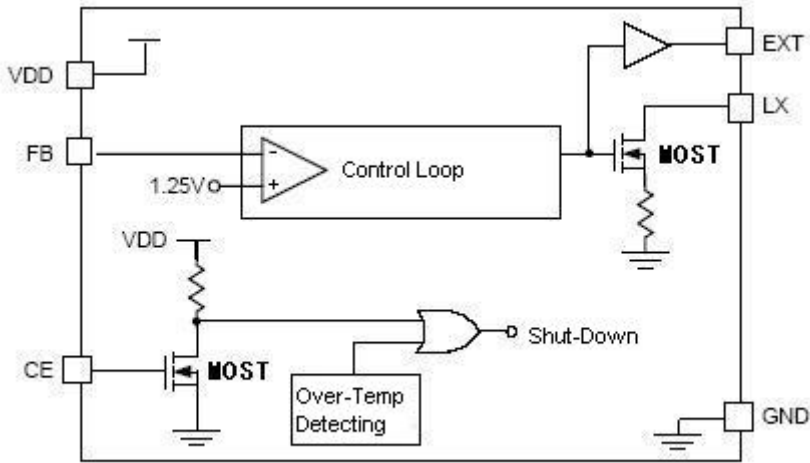

## APPLICATION INFORMATION

### ■ Output Voltage Setting

Referring to Typical Application Circuit 1, the output voltage of switching regulator ( $V_{out}$ ) is set with following equation:

$$V_{out} = (1 + R1/R2) \times 1.25V$$

### ■ Feedback Loop Design

Referring to Typical Application Circuit 1 again, the selection of R1 and R2 is a trade-off between quiescent current consumption and interference immunity besides abiding by the above equation.

- ✓ Higher R reduces quiescent current ( $I = 1.25V/R2$ )
- ✓ Lower R gives better interference immunity, and is less sensitive to interference, layout parasitic, FB node leakage, and improper probing to FB pin.

Hence for applications without standby or suspend modes lower R1 and R2 values are preferred, while for applications concerning the current consumption in standby or suspend modes, higher values of R1 and R2 are needed. Such high impedance feedback loop is sensitive to any interference, which requires careful PCB layout and avoid any interference, especially to FB pin.

To improve the system stability, a proper value capacitor between FB pin and  $V_{out}$  is suggested. An empirical suggestion is around 100pF for  $M\Omega$  feedback resistors and 10nF~0.1 $\mu$ F for lower R values.

### ■ PCB Layout Guide

PCB Layout shall follow these guidelines for better system stability:

- ✓ A full GND plane without any gap break.
- ✓ VDD to GND bypass Cap – The 1  $\mu$  F MLCC noise bypass Cap between pin 5 and pin 3 shall have short and wide connections.
- ✓ Vin to GND bypass Cap – Add a Cap close to the inductor when VIN is not an idea voltage source.
- ✓ Minimize the FB node copper area and keep it far away from noise sources.
- ✓ Minimize the parasitic capacitance connected to LX and EXT nodes to reduce the switch loss.

## TEST CIRCUIT

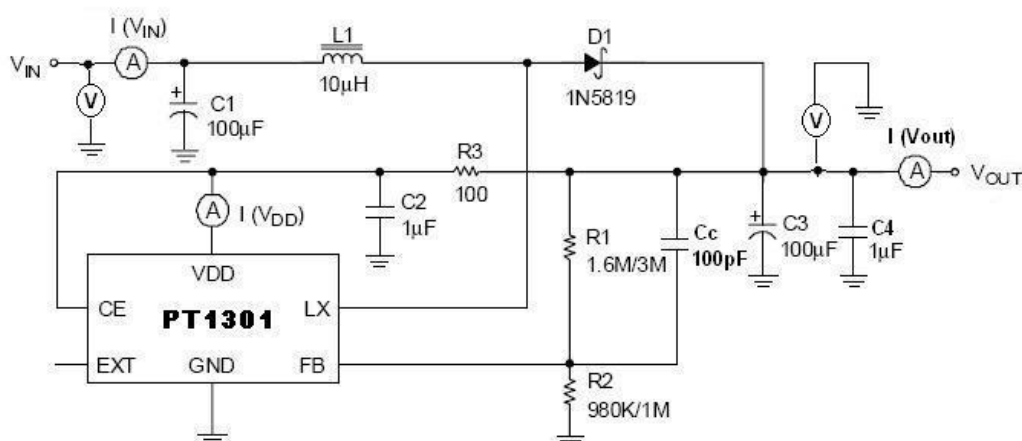

PT1301 Test Circuit

TYPICAL PERFORMANCE CHARACTERISTICS

(Refer to test circuit)

(1) Efficiency

Vout=2.0V

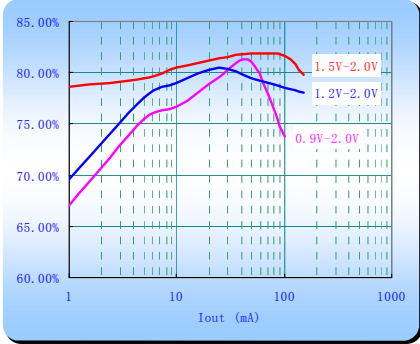

Vout=3.3V

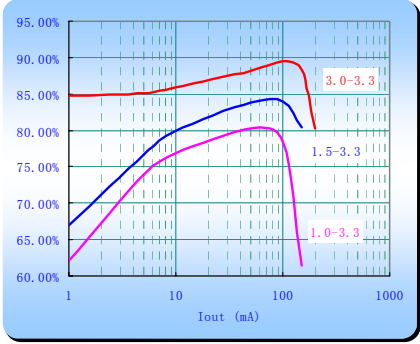

Vout=5.0V

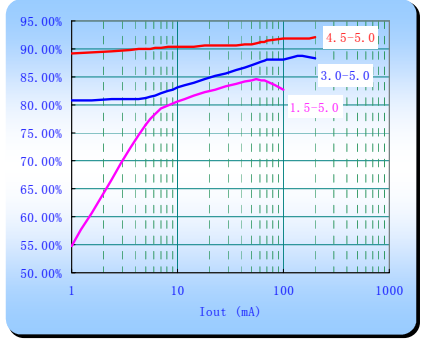

(2) Line Regulation

Vout=2.0V

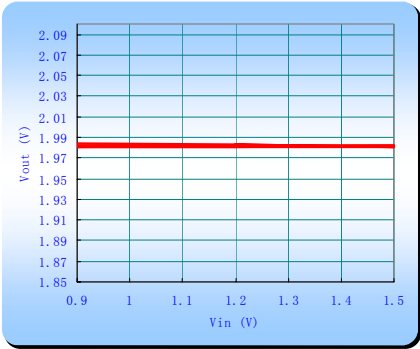

Vout=3.3V

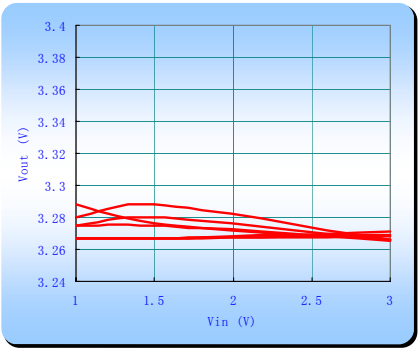

Vout=5.0V

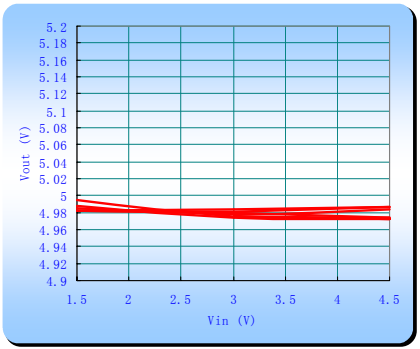

(3) Load Regulation

Vout=2.0V

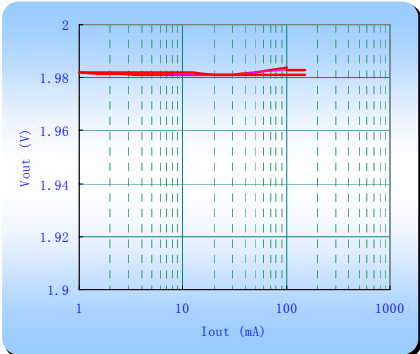

Vout=3.3V

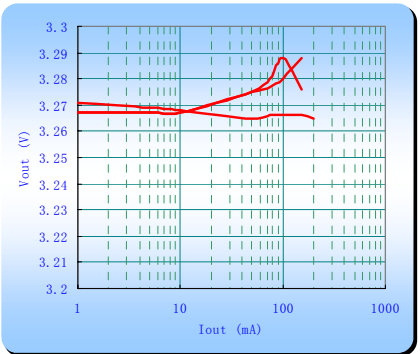

Vout=5.0V

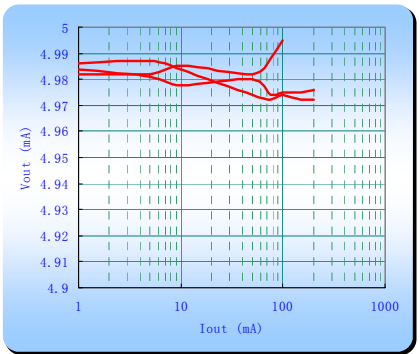

## PACKAGE INFORMATION

### (1) SOT-26

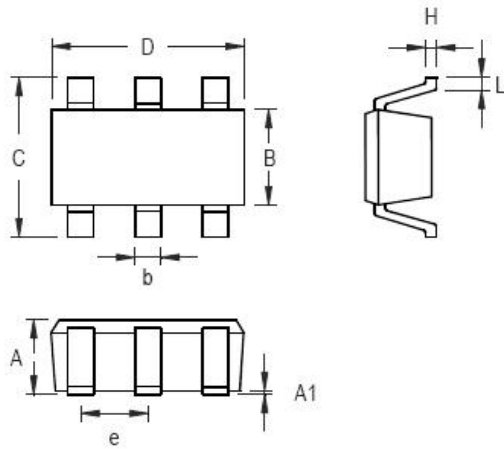

Symbol	Dimension ( in mm)		Dimension ( in Inch)	
	min	max	min	max
A	0.787	1.450	0.031	0.057
A1		0.152		0.006
B	1.397	1.803	0.055	0.071
b	0.250	0.559	0.010	0.022
C	2.591	2.997	0.102	0.118
D	2.692	3.099	0.106	0.122
e	0.838	1.041	0.033	0.041
H	0.080	0.254	0.003	0.010
L	0.300	0.610	0.012	0.024

### (2) SOT-89-5

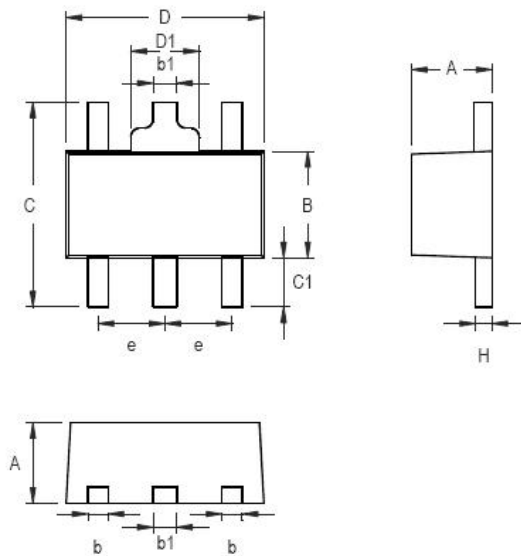

symbol	Dimension ( in mm )		Dimension ( in Inch )	
	min	max	min	max
A	1.400	1.600	0.055	0.063
b	0.460	0.520	0.014	0.020
B	2.400	2.600	0.094	0.102
b1	0.406	0.533	0.016	0.021
C		4.250		0.167
C1	0.800		0.031	
D	4.400	4.600	0.173	0.181
D1		1.700		0.067
e	1.400	1.600	0.055	0.063
H	0.380	0.430	0.014	0.017