



## SB/ESB Series Thermal Protectors

First Technology's miniature, glass encapsulated thermal protectors provide both thermal current and current overload protection.

The SB/ESB family of protectors combines First Technology's bimetal protection technology with a true glass to metal hermetic seal. This ultra-reliable combination can be used for such things as small AC fractional horsepower motors, DC motors, battery chargers, ballasts, Ni-Cad battery packs, transformers and internal protection for compressors.

First Technology is an ISO and TS registered company. We provide world-class quality products error free and on time.

### Features:

- Hermetically sealed
- Compact
- Opening temperature range of 60°C to 170°C in 5°C increments
- Snap action
- Copper or tin plated copper leads in a variety of lengths

### Benefits:

- Safe from penetration of fluids
- Ultimate corrosion protection
- No secondary insulation needed
- Can operate in high pressure environments
- Improves safety of end product



Dimensions in mm (inches)

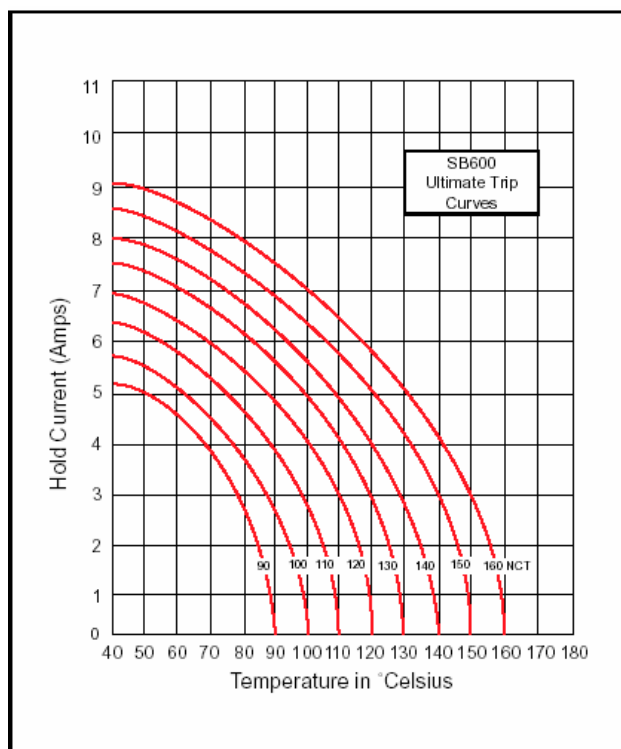
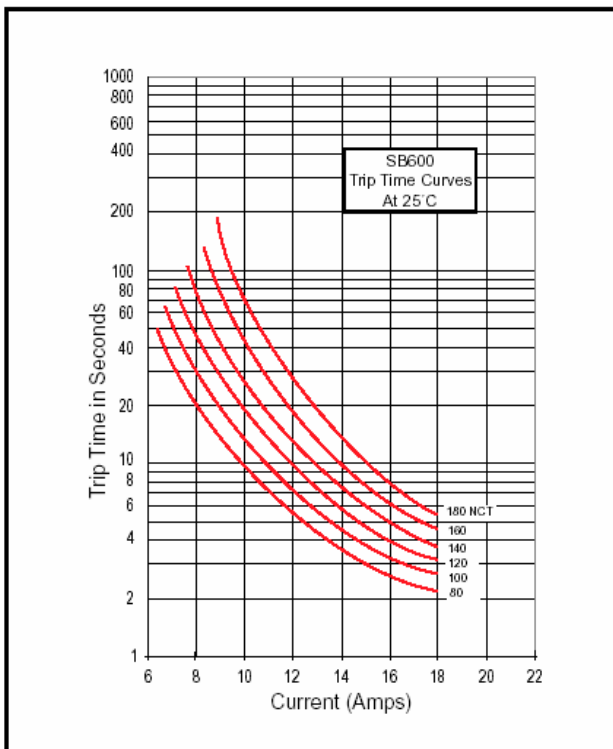
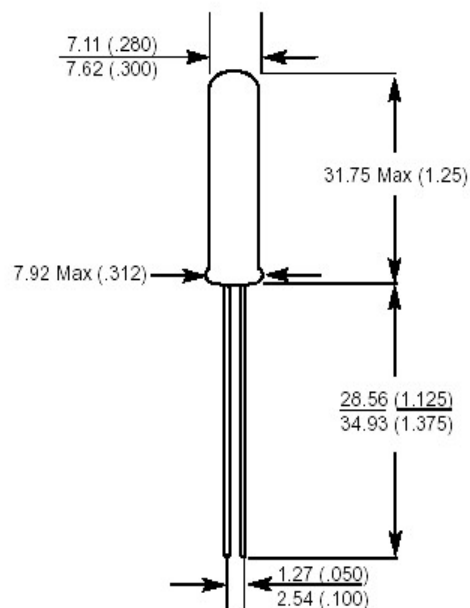
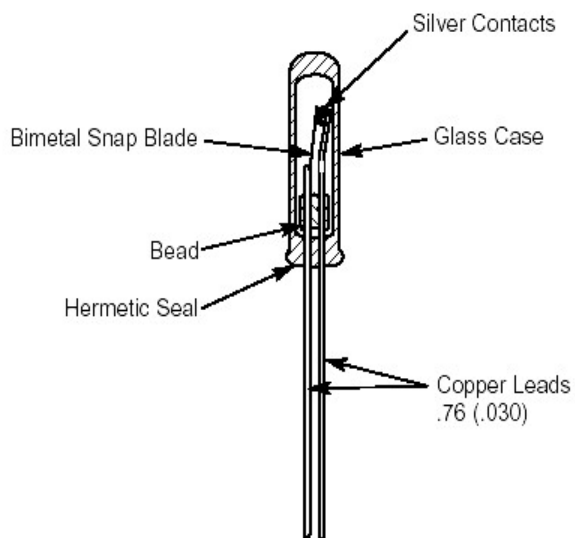

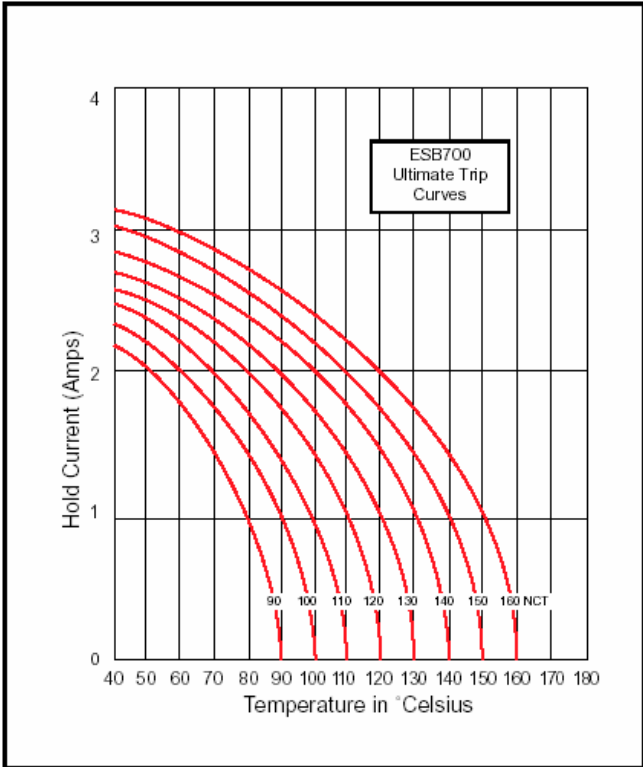
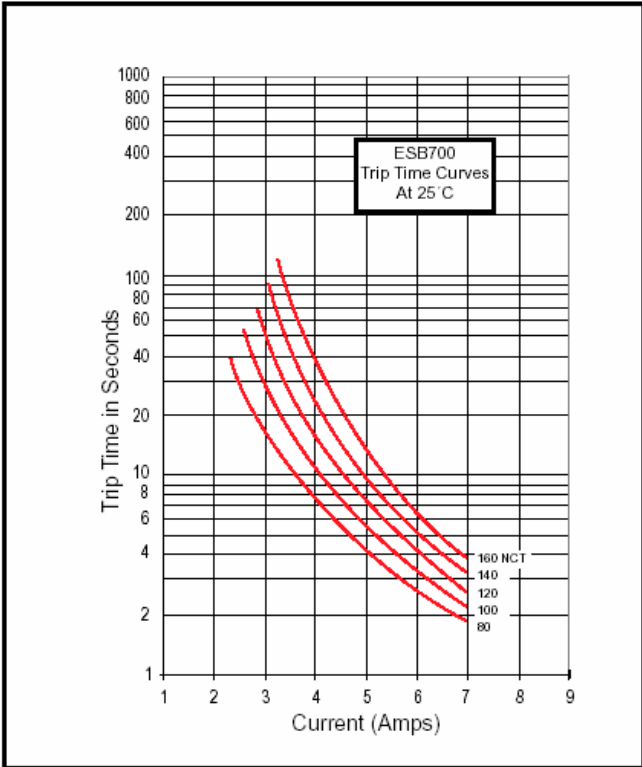
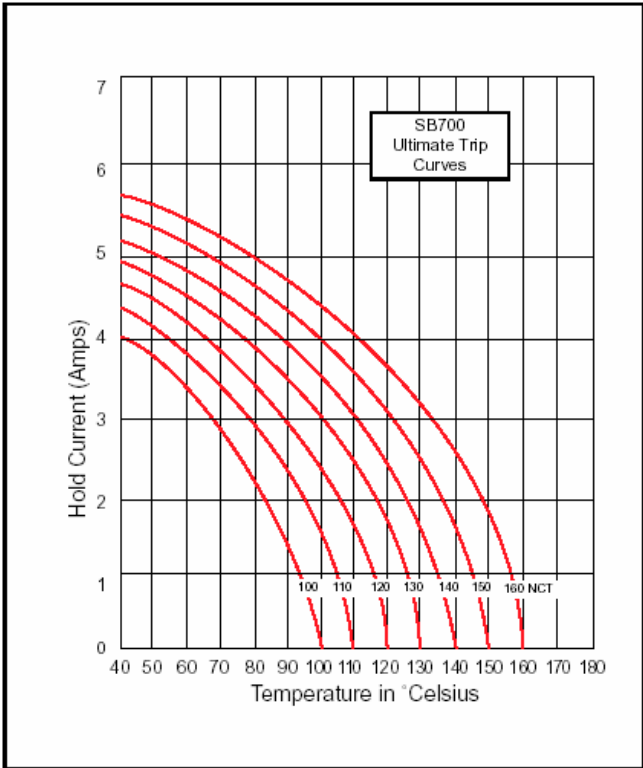
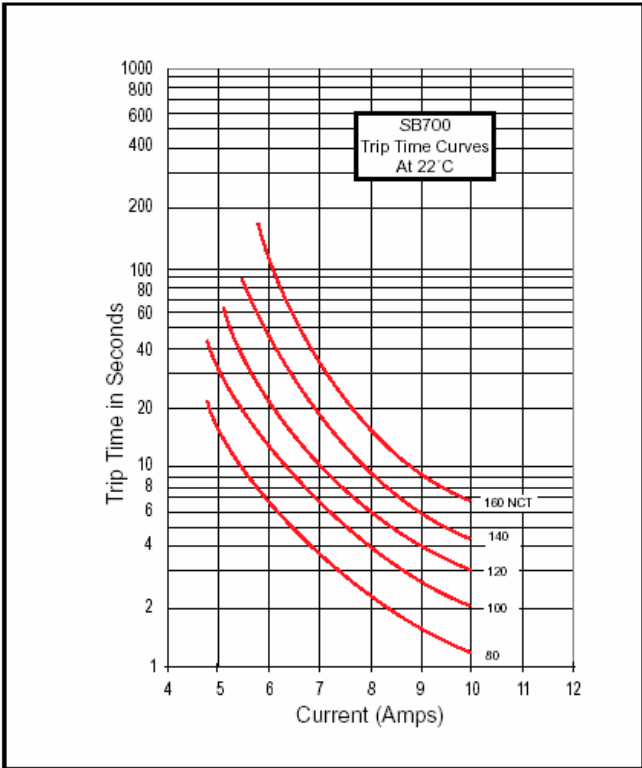

These curves are to be used only as a guide in selecting a protector for a particular application. Factors such as distance from the heat source and the method of mounting should be considered in selecting a protector. Final trip times are dependent upon terminal configuration and mounting in the application.

## Test House Approvals

BEAB – EN60730-2-1, EN60730-2-2 Open Motors (BEAB-CRC 0004)

IEC 730-2-4 Compressor Motors

UL Files E37501 & E28135, UL Nos. 547 & 873

UL IEC 730-2-2 Open Motors

CSA File LR 20529, C22.2 Nos. 77 & 24



**First Technology**  
*Innovative Solutions*

**Email:** [info@1firsttech.com](mailto:info@1firsttech.com)

**Website:** <http://www.1firsttech.com>

**North American Sales Office:**

28411 Northwestern Highway, Suite 115  
Southfield, MI 48034 USA

Tel: 800 392 3908 (USA only)

+1 248 353 6200

Fax: +1 248 353 8333

**Japan Sales Office:**

Monzennakacho Building  
9<sup>th</sup> Floor, 1-2-13 Etchujima  
Koto-Ku, Tokyo 135, Japan

Tel: +81 (0) 3 5245 6091

Fax: +81 (0) 3 5245 6092

**China Sales Office:**

Lonco Company Limited  
Unit 1125-1126, Star House  
3 Salisbury Road

Tsimshatsui, Kowloon

Hong Kong SAR

Tel: +852 2730 2330

Fax: +852 2735 6914

**European Sales Office:**

Parc International d'Entreprises Arlington  
4, Boulevard Michael Faraday  
77716 Marne La Vallée, Cedex 4, France

Tel: +33 (0) 1 60 42 89 01

Fax: +33 (0) 1 60 42 89 04

**Korea Sales Office:**

LG Palace Building, Suite 1228  
Dong-kyo-Dong, 165-8 Mapo-Gu  
Seoul 121-754, Korea

Tel: +82 (0) 2 336 7872

Fax: +82 (0) 2 336 7803