

### 1.0 Features

- Primary-side feedback eliminates opto-isolators and simplifies design
- Multi-mode operation for highest overall efficiency
- $\pm 4\%$  output voltage regulation
- No external compensation components required
- Complies with CEC/EPA/IEC no load power consumption and average efficiency regulations
- Built-in secondary constant-current control with primary-side feedback
- Low start-up current (8  $\mu\text{A}$  typical)
- Built-in soft start
- Built-in short circuit protection
- AC line under/overvoltage and output overvoltage protection
- Fixed 40 kHz switching frequency
- Available in a space-saving SOT-23 package

### 2.0 Description

The iW1689 is a high performance AC/DC power supply controller which uses digital control technology to build sensorless peak current mode PWM flyback power supplies. The device provides high efficiency along with a number of key built-in protection features while minimizing the external component count and bill of material cost. The iW1689 removes the need for secondary feedback circuitry while achieving excellent line and load regulation. It also eliminates the need for loop compensation components while maintaining stability over all operating conditions. Pulse-by-pulse waveform analysis allows for a loop response that is much faster than traditional solutions, resulting in improved dynamic load response. The built-in power limit function enables optimized transformer design in universal off-line applications and allows for a wide input voltage range.

The ultra-low start-up power and operating current at light load ensure that the iW1689 is ideal for applications targeting the newest regulatory standards for average efficiency and standby power.

### 3.0 Applications

- Low power AC/DC adapter/chargers for cell phones, PDAs, digital still cameras
- Standby supplies for televisions, DVDs, set-top boxes and other consumer electronics

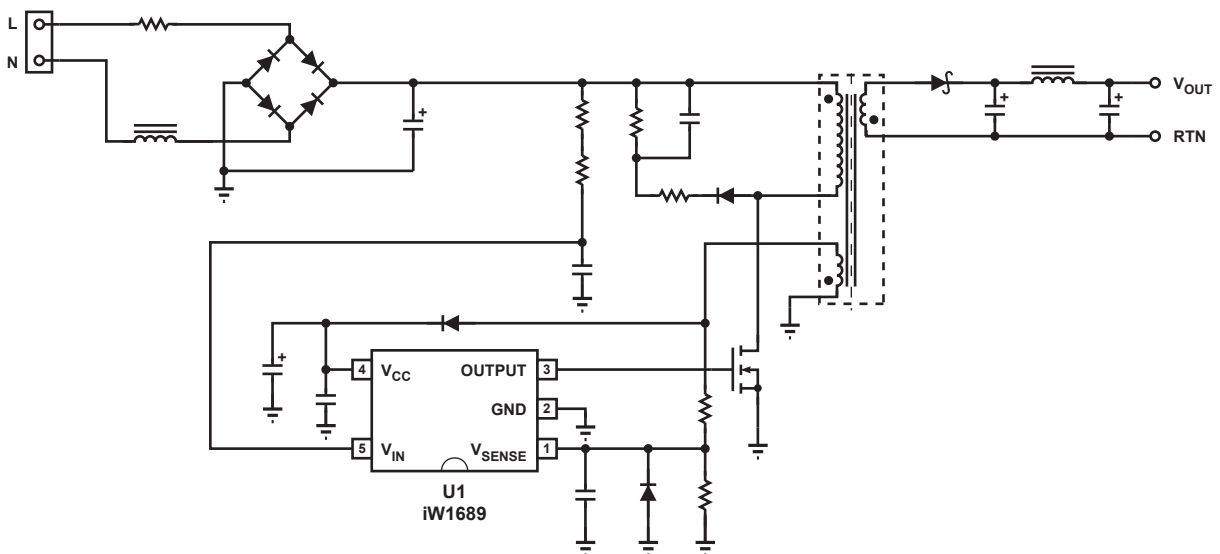
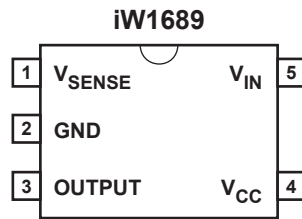

Figure 2.0.1 iW1689 Typical Application Circuit

### 4.0 Pinout Description



Pin #	Name	Type	Pin Description
1	$V_{SENSE}$	Input	Voltage sense input from the auxiliary winding.
2	GND	Ground	Ground connection.
3	OUTPUT	Output	Gate drive output for the external power MOSFET switch.
4	$V_{CC}$	Input	Supply voltage.
5	$V_{IN}$	Input	Average AC line voltage sense, rectified and attenuated. This pin also serves as the supply for the IC during start-up.

### 5.0 Absolute Maximum Ratings

Absolute maximum ratings are the parameteic values or ranges which can cause permanent damage if exceeded. For maximum safe operating conditions, refer to Electrical Characteristics in Section 6.0.

Parameter	Symbol	Value	Units
DC supply voltage range (pin 4, $I_{CC} = 20\text{mA max}$ )	$V_{CC}$	-0.3 to 18	V
DC supply current at $V_{CC}$ pin	$I_{CC}$	20	mA
Low voltage output (pin 3)		-0.3 to 18	V
$V_{SENSE}$ input (pin 1)		-0.3 to 4.0	V
$V_{IN}$ input (pin 5)		-0.3 to 18	V
Power dissipation at $T_A \leq 25^\circ\text{C}$	$P_D$	526	mW
Maximum junction temperature	$T_{J\text{MAX}}$	125	$^\circ\text{C}$
Storage temperature	$T_{STG}$	-65 to 150	$^\circ\text{C}$
Lead temperature during IR reflow for $\leq 15$ seconds	$T_{LEAD}$	260	$^\circ\text{C}$
Thermal Resistance Junction-to-Ambient	$\theta_{JA}$	190	$^\circ\text{C/W}$
ESD rating per JEDEC JESD22-A114 (HBM)		2,000	V
Latch-Up test per JEDEC 78		$\pm 100$	mA

### 12.0 Physical Dimensions

5-Lead Small Outline Transistor Package

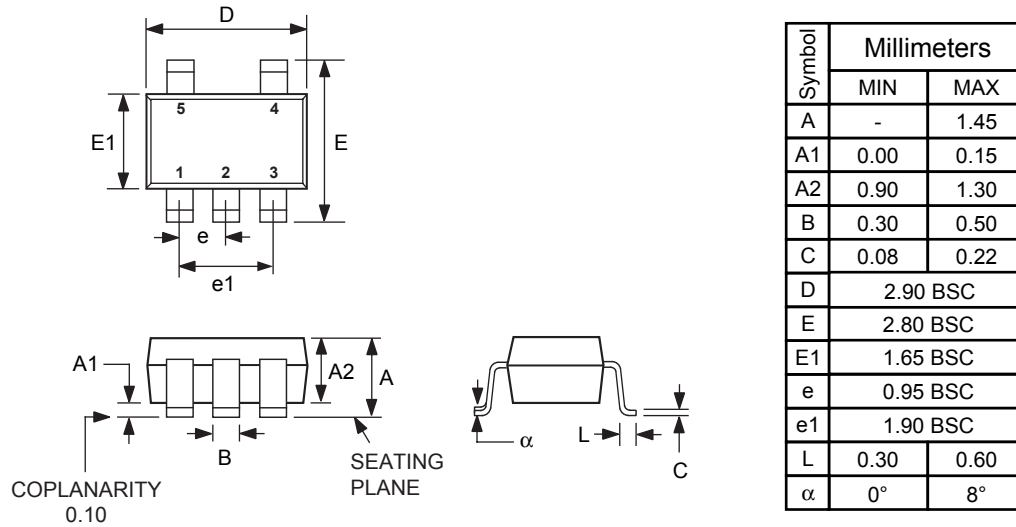

JEDEC Registered Outline: Drawing # MO-178, Variation AA  
Controlling dimensions are in millimeters

Figure 12.0.1. Physical dimensions, 5-lead SOT-23 package

### 13.0 Ordering Information

Part Number	Package	Operating Temp. Range	Description
iW1689-00	SOT23-5L	$-40^{\circ}\text{C} \leq T_A \leq 85^{\circ}\text{C}$	iW1689 PWM Controller -Tape & Reel <sup>1</sup>

\*Tape & Reel packing quantity is 3,000 units.

# iW1689

## Low-Power Off-line Digital PWM Controller



### About iWatt

iWatt Inc. is a fabless semiconductor company that develops intelligent power management ICs for computer, communication, and consumer markets. The company's patented *pulseTrain*™ technology, the industry's first truly digital approach to power system regulation, is revolutionizing power supply design.

### Trademark Information

© 2005 iWatt, Inc. All rights reserved. iWatt, the iW light bulb, and *pulseTrain* are trademarks of iWatt, Inc. All other trademarks and registered trademarks are the property of their respective companies.

### Contact Information

**Web:** <http://www.iwatt.com>

**E-mail:** [info@iwatt.com](mailto:info@iwatt.com)

**Phone:** 408-374-4200

**Fax:** 408-341-0455

**iWatt Inc.**

101 Albright Way  
Los Gatos CA 95032-1827

### Disclaimer

iWatt reserves the right to make changes to its products and to discontinue products without notice. The applications information, schematic diagrams, and other reference information included herein is provided as a design aid only and are therefore provided as-is. iWatt makes no warranties with respect to this information and disclaims any implied warranties of merchantability or non-infringement of third-party intellectual property rights.

Certain applications using semiconductor products may involve potential risks of death, personal injury, or severe property or environmental damage ("Critical Applications").

IWATT SEMICONDUCTOR PRODUCTS ARE NOT DESIGNED, INTENDED, AUTHORIZED, OR WARRANTED TO BE SUITABLE FOR USE IN LIFE-SUPPORT APPLICATIONS, DEVICES OR SYSTEMS, OR OTHER CRITICAL APPLICATIONS.

Inclusion of iWatt products in critical applications is understood to be fully at the risk of the customer. Questions concerning potential risk applications should be directed to iWatt, Inc.

iWatt semiconductors are typically used in power supplies in which high voltages are present during operation. High-voltage safety precautions should be observed in design and operation to minimize the chance of injury.