

AS/NZS 3112:2004

AS/NZS 3112:2004

Australian/New Zealand Standard™

**Approval and test specification—Plugs
and socket-outlets**



AS/NZS 3112:2004

This Joint Australian/New Zealand Standard was prepared by Joint Technical Committee EL-004, Electrical Accessories. It was approved on behalf of the Council of Standards Australia on 24 November 2004 and on behalf of the Council of Standards New Zealand on 3 December 2004.
This Standard was published on 21 December 2004.

The following are represented on Committee EL-004:

Australasian Railway Association
Australian Chamber of Commerce and Industry
Australian Electrical and Electronic Manufacturers Association
Canterbury Manufacturers Association, New Zealand
Consumer Electronic Suppliers Association
Consumers' Federation of Australia
Electrical Regulatory Authorities Council
Ministry of Economic Development (New Zealand)
National Electrical and Communications Association
Plastics Industry Pipe Association of Australia
Telarc New Zealand
Testing Interests (Australia)

Keeping Standards up-to-date

Standards are living documents which reflect progress in science, technology and systems. To maintain their currency, all Standards are periodically reviewed, and new editions are published. Between editions, amendments may be issued. Standards may also be withdrawn. It is important that readers assure themselves they are using a current Standard, which should include any amendments which may have been published since the Standard was purchased.

Detailed information about joint Australian/New Zealand Standards can be found by visiting the Standards Web Shop at www.standards.com.au or Standards New Zealand web site at www.standards.co.nz and looking up the relevant Standard in the on-line catalogue

Alternatively, both organizations publish an annual printed Catalogue with full details of all current Standards. For more frequent listings or notification of revisions, amendments and withdrawals, Standards Australia and Standards New Zealand offer a number of update options. For information about these services, users should contact their respective national Standards organization

We also welcome suggestions for improvement in our Standards, and especially encourage readers to notify us immediately of any apparent inaccuracies or ambiguities. Please address your comments to the Chief Executive of either Standards Australia or Standards New Zealand at the address shown on the back cover

AS/NZS 3112:2004

Australian/New Zealand Standard™

**Approval and test specification—Plugs
and socket-outlets**

Originated in Australia as C112—1937.
Originated in New Zealand as part of NZSS 198—1939
Previous edition AS/NZS 3112:2000.
Sixth edition 2004

COPYRIGHT

© Standards Australia/Standards New Zealand

All rights are reserved. No part of this work may be reproduced or copied in any form or by any means, electronic or mechanical, including photocopying, without the written permission of the publisher.

Jointly published by Standards Australia, GPO Box 5420, Sydney, NSW 2001 and Standards New Zealand, Private Bag 2439, Wellington 6020

ISBN 0 7337 6418 5

PREFACE

This Standard was prepared by the Joint Standards Australia/Standards New Zealand Committee EL-004, *Electrical Accessories* to supersede AS/NZS 3112:2000 on publication.

The objective of this Standard is to provide the Australian and New Zealand electrical industry including manufacturers, test laboratories and regulators with requirements and test methods for plugs and socket-outlets.

This Standard is one of a series of approval and test specifications to be read in conjunction with AS/NZS 3100, *Approval and test specification—General requirements for electrical equipment*. The purpose of this series is to outline conditions which must be met to secure approval for the sale and use of electrical equipment. Only safety matters and related conditions are covered.

The essential safety requirements in AS/NZS 3820 that could be applicable to plugs and socket-outlets are covered by this Standard taken in conjunction with any other relevant requirements affecting safety.

This Standard was revised to introduce the following technical and editorial changes:

- (a) Amendments 1 and 2 to AS/NZS 3112:2000 have been incorporated into the text.
- (b) Requirements for the shape of the ends of plug pins.
- (c) Pin bending test.
- (d) Changes to fire test requirements.
- (e) Requirements with regards to any interference between metal contacts and thermoplastic or resilient mouldings.
- (f) Lateral strain test for two pin plugs.
- (g) Updating of cross-references to referred Standards and other minor editorial changes.

Notes to the text in the body of the Standard are not mandatory parts of the Standard.

The term 'normative' has been used in this Standard to define the application of the appendix to which it applies. A 'normative' appendix is an integral part of a Standard.

This Standard does not provide all the necessary conditions for a contract.

CONTENTS

	<i>Page</i>
SECTION 1 SCOPE AND GENERAL	
1.1 SCOPE	6
1.2 APPLICATION	6
1.3 REFERENCED DOCUMENTS	6
1.4 DEFINITIONS	7
SECTION 2 PLUGS	
2.1 TERMINALS AND INTERNAL CONNECTIONS	9
2.2 PLUG PINS	9
2.3 INSULATING MATERIALS	11
2.4 NON-REWIREABLE PLUGS	11
2.5 MEANS OF ENTRY AND CORD ANCHORAGE FOR FLEXIBLE CORD	11
2.6 RADIO INTERFERENCE SUPPRESSION DEVICES	12
2.7 FINGER-GRIP	13
2.8 RATINGS AND DIMENSIONS OF LOW VOLTAGE PLUGS	13
2.9 INTERNAL CONNECTIONS	14
2.10 ARRANGEMENT OF EARTHING CONNECTIONS	14
2.11 FUSES	14
2.12 MARKING	14
2.13 TESTS ON PLUGS	15
SECTION 3 SOCKET-OUTLETS	
3.1 TERMINALS AND INTERNAL CONNECTIONS	37
3.2 PROHIBITED ARRANGEMENTS	37
3.3 SOCKET-OUTLET CONTACTS	37
3.4 INSULATING MATERIALS	39
3.5 RADIO INTERFERENCE SUPPRESSORS	39
3.6 DIMENSIONS	39
3.7 ARRANGEMENT OF EARTHING CONNECTIONS	41
3.8 PREVENTION OF CONTACT WITH LIVE PINS	41
3.9 FUSES	42
3.10 FLOOR SOCKET-OUTLETS	42
3.11 SWITCHED SOCKET-OUTLETS	42
3.12 SHUTTERED SOCKET-OUTLETS	43
3.13 MARKING	43
3.14 TESTS FOR SOCKET-OUTLETS	44
APPENDICES	
A GAUGE FOR THREE-PIN FLAT-PIN PLUGS	56
B GAUGE FOR TWO-PIN FLAT-PIN PLUGS WITH PARALLEL PINS	57
C THREE-PIN TEST PLUG WITH FLAT PINS FOR FULL-INSERTION TEST AND THE FINGER TEST DURING NORMAL INSERTION TEST	58
D THREE-PIN TEST PLUG WITH FLAT PINS FOR ABNORMAL INSERTION TEST	59
E PLUGS AND SOCKET-OUTLETS FOR USE IN EXTRA-LOW VOLTAGE CIRCUITS	60
F GAUGE FOR FLAT AND ROUND PIN PLUGS	61

G	THREE-PIN TEST PLUG WITH FLAT AND ROUND PINS FOR THE FULL-INSERTION TEST AND THE FINGER TEST DURING NORMAL INSERTION TEST	62
H	DIMENSIONS FOR PLUGS AND SOCKET-OUTLETS, IP-RATED, WITH THREADED RETAINING DEVICES	63
I	(VOID)	64
J	EQUIPMENT WITH INTEGRAL PINS FOR INSERTION INTO SOCKET-OUTLETS	65
 FIGURES		
2.1	DIMENSIONS OF PLUGS	28
2.2	APPARATUS FOR FLEXING TEST	32
2.3	FORM OF PIN	33
2.4	DIMENSIONS OF INSULATION ON INSULATED LIVE PINS	33
2.5	PRESSURE TEST APPARATUS FOR INSULATION ON INSULATED PLUG PINS AT HIGH TEMPERATURE	34
2.6	IMPACT TEST APPARATUS FOR INSULATION ON INSULATED PLUG PINS AT LOW TEMPERATURE	35
2.7	ABRASION TEST APPARATUS FOR INSULATION ON INSULATED PIN PLUGS	36
2.8	APPLICATION OF FORCE FOR PIN BENDING TEST	36
3.1	GAUGE FOR DEPTH OF NO-CONTACT TEST	51
3.2	SOCKET-OUTLET FACE PROFILE IN ACCORDANCE WITH CLAUSE 3.6.1 ITEM (a)	52
3.3	SOCKET-OUTLET FACE PROFILE IN ACCORDANCE WITH CLAUSE 3.6.1 ITEM (b)	52
3.4	AREA OF LIMITED PROJECTION	52
3.5	FULLY RECESSED SOCKET-OUTLET	53
3.6	DEVICE FOR CHECKING THE RESISTANCE TO LATERAL STRAIN (THREE-PIN GAUGE)	54
3.7	DEVICE FOR CHECKING THE RESISTANCE TO LATERAL STRAIN (TWO-PIN GAUGE)	55
A1	GAUGE FOR THREE-PIN 250 V MAX FLAT-PIN PLUGS	56
B1	GAUGE FOR TWO-PIN FLAT-PIN 125 V MAX. PLUGS (WITH PARALLEL PINS)	57
C1	THREE-PIN TEST PLUG FOR CHECKING THREE-PIN FLAT-PIN 250 V MAX. SOCKET-OUTLETS AGAINST THE STANDARD TEST FINGER IN ACCORDANCE WITH CLAUSES 3.3.4 AND 3.8.1	58
D1	THREE-PIN TEST PLUG FOR CHECKING THREE-PIN FLAT-PIN 250 V MAX. SOCKET-OUTLETS AGAINST INCORRECT INSERTION OF PLUGS, IN ACCORDANCE WITH CLAUSE 3.8.2	59
E1	DIMENSIONS OF EXTRA-LOW VOLTAGE FLAT-PIN PLUGS	60
F1	GAUGE FOR FLAT AND ROUND PIN PLUGS	61
G1	THREE-PIN TEST PLUG WITH FLAT AND ROUND PINS FOR TESTS TO CLAUSES 3.3.4 AND 3.8.1	62
H1	DIMENSIONS FOR IP-RATED PLUGS AND IP-RATED SOCKETS WITH THREADED RETAINING DEVICE	63
J1	ARRANGEMENT FOR DETERMINATION OF PIVOT	67
 TABLES		
2.1	RANGE OF FLEXIBLE CORDS	12
2.2	PLUGS—TESTS TO BE APPLIED AND ORDER OF APPLICATION	17
2.3	TEST VOLTAGES FOR HIGH VOLTAGE TEST	18

	<i>Page</i>
2.4 LOADS FOR CORD ANCHORAGE TEST	19
3.1 MAXIMUM DIMENSIONS OF PIN ENTRY APERTURES	40
3.2 SOCKET-OUTLETS—TESTS TO BE APPLIED AND ORDER OF APPLICATION	45
3.3 TEST VOLTAGES FOR HIGH VOLTAGE TEST	46
3.4 SIZE OF CABLES FOR TEST OF TEMPERATURE RISE	47

STANDARDS AUSTRALIA/STANDARDS NEW ZEALAND

Australian/New Zealand Standard
Approval and test specification—Plugs and socket-outlets

SECTION 1 SCOPE AND GENERAL

1.1 SCOPE

This Standard specifies essential safety requirements for plugs and socket-outlets, as defined in Clause 1.4, intended for use at extra-low or low voltages and a rated current not exceeding 32 A for household or similar purposes. (For extra-low voltage plugs and socket-outlets, see Appendix E.)

This Standard does not apply to the following:

- (a) Appliance couplers (see AS/NZS 60320.1).
- (b) Installation couplers (see AS/NZS 3131:1995 or AS/NZS 61535.1).
- (c) Plugs, socket-outlets and couplers for general industrial applications (see AS/NZS 3123).
- (d) Plugs and socket-outlets for moveable appliances (see AS/NZS 3131).

1.2 APPLICATION**1.2.1 General requirements of AS/NZS 3100**

This Standard shall be read in conjunction with AS/NZS 3100 and the appropriate provisions of AS/NZS 3100 shall apply to the construction of a plug or socket-outlet and the insulation and safeguarding of parts which normally carry current.

1.2.2 Specific requirements of this Standard

A plug or socket-outlet shall be considered to comply with this Standard only if it complies with all the appropriate requirements of this Standard and passes the relevant tests specified herein.

NOTES:

- 1 Plugs, socket-outlets and connectors incorporating retaining means of the type specified in AS/NZS 3123, or similar, need not comply with all general dimensional requirements of this Standard, so long as the safe functioning of accessories in a particular system is not impaired. Where appropriate, dimensions relevant to specified pin configurations are applied.
- 2 Requirements for equipment with integral pins for insertion into socket-outlets are provided in Appendix J.

1.3 REFERENCED DOCUMENTS

The following documents are referred to in this Standard.

AS

- 1722 Pipe threads of Whitworth form
- 1722.2 Part 2: Fastening pipe threads
- 60068 Environmental testing
- 60068 2.30 Part 2.30: Tests—Test DB and guidance: Damp heat, cyclic (12 + 12-hour cycle)
- 60068 2.32 Part 2.32: Tests—Test Ed: Free fall

- AS
60529 Degrees of protection provided by enclosures (IP Code)
- AS/NZS
3000 Electrical installations (known as the Australian/New Zealand Wiring Rules)
- 60269 Low voltage fuses
60269.1 Part 1: General requirements
60269.3.0 Part 3.0: Supplementary requirements for fuses for use by unskilled persons (fuses mainly for household and similar applications)
- 60320 Appliance couplers for household and similar general purposes
60320.1 Part 1: General requirements
- 60695 Fire hazard testing
60695.2 Part 2: Glowing/hot wire based test methods
60695.2.11 Part 2.11: Glow-wire flammability test method for end-products
- 61535 Installation couplers
61535.1 Part 1: General requirements
- IEC
60384-14 Fixed capacitors for use in electronic equipment, Part 14: Sectional specification—Fixed capacitors for electromagnetic interference suppression and connection to the supply mains
- BS
646 Cartridge fuse-links (rated up to 5 amperes) for a.c. and d.c. service

APPROVAL AND TEST SPECIFICATIONS

- AS/NZS
3100 General requirements for electrical equipment
- 3121 Insulating mouldings
- 3123 Plugs, socket-outlets and couplers for general industrial application
- 3131 Plugs and socket-outlets for use in installation wiring systems
- 3133 Air break switches

1.4 DEFINITIONS

For the purpose of this Standard, the definitions in AS/NZS 3100 and those below shall apply.

1.4.1 Fully recessed socket-outlet

A socket-outlet provided with additional protection in accordance with Clause 3.6.4.

NOTE: This additional protection is designed to prevent access to live pins of plugs complying with Figure 2 1(e)

1.4.2 Insulated pin plug

A plug with all live pins having an insulated portion in accordance with this Standard.

NOTE: Both active and neutral pins are considered to be live

1.4.3 Non-rewireable plug

A plug constructed so that it forms an integral unit with its flexible cable or cord such that—

- (a) the flexible cable or cord cannot be detached from the accessory without making it permanently useless; or

- (b) the flexible cable or cord cannot be replaced by hand or by using a general purpose tool.

1.4.4 Plug

An accessory having pins designed to engage with the contacts of a socket-outlet and incorporating means for the electrical connection and mechanical retention of flexible cables or cords.

1.4.5 Plug, IP-rated, with threaded retaining device

A plug complying with this Standard provided with an internal threaded retaining device complying with this Standard and suitable for joining with a socket-outlet, IP-rated, with threaded retaining device.

1.4.6 Rewireable plug

A plug constructed so that the flexible cable or cord can be replaced.

1.4.7 Socket-outlet

An accessory having socket-contacts designed to engage with the pins of a plug and having terminals for the connection of cables or cords.

1.4.8 Socket-outlet, IP-rated, with threaded retaining device

A socket-outlet complying with this Standard provided with an external threaded retaining device complying with this Standard and suitable for joining with a plug, IP-rated, with threaded retaining device.

SECTION 2 PLUGS

2.1 TERMINALS AND INTERNAL CONNECTIONS

2.1.1 Materials

Terminals and internal connections, intended primarily for carrying current, shall be of a corrosion-resisting metal having sufficient hardness and rigidity for the intended application.

2.1.2 Construction of terminals

The terminals shall be of suitable size and form to accommodate the conductors of a flexible cord of current-carrying capacity corresponding to the marked current rating of the plug.

Facilities shall be provided to prevent slipping or spreading of the conductors or conductor strands. Where the facilities are such that the conductor is to be located around the shank of the terminal screw and clamped under the screw head, the following requirements shall apply:

- (a) When the terminal screw is screwed in to the limit of its thread, the clearance between the head of the screw and the washer or other means of retention of the conductor shall not exceed 0.4 mm.
- (b) The terminal screw shall be of sufficient length to enable it to be backed off sufficiently from the washer or other means of retention of the conductor so that the conductor may be located around the shank without difficulty.
- (c) Where the means of retention of the conductor is not continuous, e.g. prongs, there shall be at least three points of retention and the maximum angle between any two points shall not exceed 150°.
- (d) Where the means of retention of the conductor is continuous, e.g. portion of the insulating moulding, the angle subtended by the arc of the means of retention shall be not less than 180°.

2.2 PLUG PINS

2.2.1 Material for pins

Current carrying parts of plug pins shall be of metal having, under the conditions occurring in the plug, sufficient mechanical strength, electrical conductivity and resistance to corrosion adequate for their intended use. Compliance shall be checked by inspection and, where in doubt, by chemical analysis.

Examples of suitable materials, when used within the permissible temperature range and under normal conditions of chemical pollution, are—

- (a) copper;
- (b) copper alloy containing at least 58% copper for parts made from cold rolled sheet or at least 50% copper for other parts; or
- (c) stainless steel containing at least 13% chromium and not more than 0.09% carbon.

2.2.2 Assembly of pins

Where, during assembly, pins may become detached from the body of a plug yet remain attached to the conductors of a flexible cord, or have to be detached from the body to enable connection, it shall not be possible for a plug to be assembled with any pin located in a position other than that intended.

In a plug made of resilient insulating material, the pins and terminals shall be held securely in position.

NOTE: See Clause 2.8 for dimensions of flat pins.

2.2.3 Form of pin

The plug pins shall be adequately proportioned throughout and the portion adjacent to the connection shall be designed so as not to introduce a stress concentration which may lead to a fracture of the pin, and shall be suitably shaped to prevent abrasion or cutting of conductor strands due to flexure in normal use.

The exposed ends of plug pins shall have a bevel or radius to facilitate entry into socket-outlets and to operate shutters.

Round pins shall have a semicircular end profile.

Flat pins with the following width and thickness profiles are deemed to comply:

- (a) Flat-pins with a radius on the end with side bevels may have a—
 - (i) width profile with an arc on the centre line of the pin of—
 - (A) 6 mm for all pins of 10 A plugs and live pins of 15 A plugs; or
 - (B) 11 mm for earth pins of 15 A plugs and all pins of 20 A plugs; and
 - (ii) thickness profile with each corner bevelled 0.3 mm to 0.4 mm along the sides, finishing along the pin at 0.8 mm to 1.0 mm.
- (b) Flat-pins square on the end with corner bevels and side bevels may have a—
 - (i) width profile which is square and with each corner bevelled 0.6 mm finishing along the pin at 0.8 mm to 1.0 mm; and
 - (ii) thickness profile with each corner bevelled 0.3 mm to 0.4 mm along the sides, finishing along the pin at 0.8 mm to 1.0 mm.
- (c) Flat-pins square on the end with corner bevels and a radius on the sides may have a—
 - (i) width profile which is square and with each corner bevelled 0.6 mm finishing along the pin at 0.8 mm to 1.0 mm; and
 - (ii) thickness profile with a radius of approximately half the material thickness along the sides, finishing along the pin at 0.8 mm to 1.0 mm.

The contact portion of the pins shall be smooth and free from openings or indentations; however, for flat pin plugs, a longitudinal seam or opening in the contact portion of one face up to 0.3 mm width is deemed to comply. The thickness of any pin at the seam is measured using a 0.3 mm thick blade as indicated in Figure 2.3.

NOTE: This is to ensure satisfactory mating with edge type socket contacts.

The exposed portion of earthing pins and pins other than insulated pins shall be free from any non-metallic coverings or coatings.

2.2.4 Insulation of plug pins

Live parts of insulated pin plugs shall not be exposed when the plug is partially or fully engaged with the associated socket.

Compliance for plugs of the types shown in Figure 2.1 is checked by measurement to Figure 2.4.

For the purpose of this Clause, lacquer, enamel or sprayed insulating coating is not considered to be insulation material.

Plugs up to 15 A complying with Figure 2.1(a), 2.1(c) or 2.1(f) (flat live pins) and of the insulated pin plug type do not need to comply with the $R20 0 \pm 1$ mm requirement of Figure 2.1(e).

All live pins on low voltage plugs except for those shown in Figure 2.1(a2), (b) and (g) shall be of the insulated pin type from 3 April 2005.

The colour green or a combination of green and yellow shall not be used for the insulation of insulated pins.

2.3 INSULATING MATERIALS

2.3.1 General

Except for ceramics, all insulating materials of a plug shall comply with Clause 2.13.11.

The moulding or encapsulating material shall be of even texture throughout and of suitable proportions to ensure adequate physical properties. It shall be free of voids which may lessen significantly the mechanical strength or electrical properties of the plug.

2.3.2 Plug body

The insulating portion of a plug body shall consist of—

- (a) insulating material having properties not inferior to those specified in AS/NZS 3121 for insulating mouldings having a temperature class of 80°C; or
- (b) ceramic material of a type such that, after 48 h immersion in water and after all visible drops of water have been removed from the surface by means of a clean dry cloth, it shall not have increased in mass by more than 2%.

2.3.3 Plug cover

The insulating material of a plug cover shall have properties not inferior to those specified in AS/NZS 3121 for insulating mouldings having a temperature class of 60°C.

2.4 NON-REWIREABLE PLUGS

A non-rewireable plug shall comply with the following requirements:

- (a) Each conductor shall be rigidly and effectively attached to the appropriate plug pin. Each plug pin, with the conductor attached to it, and the insulation of the conductor adjacent to the connection, shall be adequately supported and secured in position in the plug.
- (b) The conductors shall be attached to the plug pins by clamping, crimping, welding or soldering. Soldered connections shall comply with AS/NZS 3100. Soldering shall be used only to supplement a clamped or crimped connection unless the design of the plug is such that the soldered connection will not be subjected to flexure or undue mechanical stress during normal use of the plug and cord set.
- (c) The flexible cord, complete with any braid, cover or sheath, shall be taken into the body of the plug. The complete flexible cord shall be securely held in position in the plug by the moulding, encapsulation, cover or other suitable means that will effectively prevent any part of the flexible cord from moving out of the plug during normal use.

2.5 MEANS OF ENTRY AND CORD ANCHORAGE FOR FLEXIBLE CORD

2.5.1 General

Provision shall be made for entry of a flexible cord together with any protective covering, and for effective anchorage of the flexible cord or range of cords which the plug is intended to accommodate, so that any stress on the terminals will be substantially reduced. For rewirable plugs, the anchorage shall be effective for the range of flexible cords listed in Table 2.1, except where—

- (a) there is a special aperture for the accommodation of only one type or size of flexible cord, a circular hole not being regarded as restricting the entry of cords having diameters smaller than that of the hole; or
- (b) the cord or range of cords as specified by the manufacturer is marked as required by Clause 2.12.3(d).

The cord anchorage shall comply with Clause 2.13.4. In addition, except where the plug is specially designed to accept only parallel two-core unsheathed flexible cord, the following shall apply to rewirable resilient and thermoplastic plugs of the type referred to in Figure 2.1(a) and Figure 2.1(b):

Two means of cord grip shall be provided: one which anchors each insulated core by a pillar, post, grip, tortuous path or equally effective means; the second which grips or clamps the sheathing of the flexible cord. Both means may be incorporated in one device.

2.5.2 Side-entry (of the flexible cord) plugs

In addition to complying with the general requirements of Clause 2.5.1, low voltage flat-pin side-entry plugs having ratings up to and including 15 A, shall comply with Figure 2.1(d1) or Figure 2.1(d2), as appropriate.

NOTE: Figure 2.1(d1) is primarily intended for general-purpose side-entry plugs, whereas Figure 2.1(d2) allows for side-entry plug-in devices and special purpose side-entry plugs, the maximum size of which is not limited. Attention is also drawn to Note 4 of Figure 2.1

The angle of entry of the flexible cord for side-entry plugs of the Figure 2.1(d2) type is not specified. However, for side-entry plugs of this type, the edge of the flexible cord, including any protective covering or cord guard, closest to the plug face, shall be not less than 8.6 mm from the plug face.

NOTE: Attention is drawn to Figure 2.1(d2).

TABLE 2.1
RANGE OF FLEXIBLE CORDS

Plug rating A	Flexible cord	
	Conductor size, mm ²	Type
≤7.5	0.5, 0.75	Appropriate to design of plug
>7.5 ≤10	0.75, 1.0	Light duty Ordinary duty Heavy duty
>10	Maximum size appropriate to design of plug and next smallest size	Ordinary duty or heavy duty as appropriate

2.6 RADIO INTERFERENCE SUPPRESSION DEVICES

Where a capacitor is incorporated in a plug for the suppression of radio or television interference, the capacitor shall comply with IEC 60384-14.

2.7 FINGER-GRIP

A plug shall be provided with a functionally adequate finger-grip to permit easy insertion into, or withdrawal from its corresponding sockets. Plugs complying with Figure 2.1 (a1), (c), (d), (f) or (g) shall permit easy insertion, or withdrawal from, a fully recessed socket-outlet complying with Figure 3.5.

Compliance is checked by inspection.

2.8 RATINGS AND DIMENSIONS OF LOW VOLTAGE PLUGS

2.8.1 General

Low voltage flat-pin plugs and low voltage plugs having one round earth pin and two flat live pins or two round live pins and one flat earth pin, having ratings up to and including 20 A, shall conform to the appropriate dimensions shown in Figure 2.1

In addition to the dimensions of Figure 2.1, the distance between a live pin of any plug and the edge of the moulding of the plug, shall be not less than 9 mm. Where doubt exists regarding compliance with this requirement, the gauge of Figure A1, Appendix A or Figure B1, Appendix B, or Figure F1(a) or F1(b), Appendix F, as appropriate, shall be placed over the pins so as to contact the highest points associated with the plug face. Using a 1.5 mm feeler gauge of greater than 3 mm width and applied without undue force between the plug and the plug gauge, penetration to within 9 mm of the live pin shall not be possible.

No point on the front face of the plug shall protrude by more than 0.5 mm. The pin lengths shall be measured from a plane normal to the pins passing through the highest point on the front face of the plug, to the end of the pin.

NOTE: Examples of protrusions are moulding irregularities and marking

2.8.2 Integrally moulded plug and cord

A two-core flexible cord may be integrally moulded with a three-pin plug.

2.8.3 Two-pin flat-pin plugs with non-parallel pins

A low voltage, two-pin, flat-pin plug having pins arranged as in Figure 2.1(c) shall have a current rating not exceeding that of the cord to which it is connected. Such plugs shall be permitted only where the plug has a maximum rating of 10 A and is integrally moulded.

2.8.4 Compliance with dimensional requirements of Figure 2.1

Low voltage plugs shall be checked for compliance with the prescribed dimensions of Figure 2.1 by any suitable means, except that compliance with the nominal dimensions covering disposition of pins, i.e. spacing from centre and angular orientation, shall be checked by a gauge complying with Appendix A, Appendix B or Appendix F, as appropriate.

In addition, low voltage flat-pin, or combination of flat and round pin, plugs having ratings up to 15 A of the Figure 2.1(a1), Figure 2.1(c), Figure 2.1(d), Figure 2.1(f) or Figure 2.1(g) type, shall comply with the dimensional requirements of Figure 2.1(e).

Plugs with insulated pins, complying with this Standard, need not comply with dimension $R20 \pm 1.0$ mm of Figure 2.1(e) (see Note 1 of Figure 2.1).

Compliance shall be checked by any suitable means.

2.8.5 Plugs, IP-rated, with threaded retaining device

Where an IP-rated plug has a threaded retaining device, the dimensions of the retaining device shall comply with Appendix H. The pitch circle diameter (PCD) on the threaded retaining device shall be as shown in Figure H1(d).

2.9 INTERNAL CONNECTIONS

The design and construction of a plug provided with earthing connections shall be such that when the plug is correctly wired and completely assembled—

- (a) a loose terminal screw or conductive material cannot bridge any live parts or earthing parts;
- (b) the earthing parts are effectively isolated from contact with a live conductor which may become detached; and
- (c) the live parts are effectively isolated from contact with any earthing conductor which may become detached.

Any connections for auxiliary devices, such as radio interference suppressors or visual indicators, shall comply with the above requirements.

2.10 ARRANGEMENT OF EARTHING CONNECTIONS

The earthing pin of any low voltage, three-pin plug shall be that pin which is radial to the circle embracing the pins (see Figure 2.1(a), Figure 2.1(f) and Figure 2.1(g)).

2.11 FUSES

Any fuse incorporated in a plug and rated at not more than 5 A shall comply with BS 646.

Any fuse incorporated in a plug and rated at more than 5 A shall be a cartridge type complying with AS/NZS 60269 3.0 and the relevant requirements of AS/NZS 60269 1.

2.12 MARKING

2.12.1 Required marking

The plug shall be marked with the following information in accordance with AS/NZS 3100:

- (a) The name, trade name, or mark of the manufacturer or of the responsible vendor.
- (b) The current rating in amperes.
- (c) The voltage.
- (d) If not the only type of plug marketed by the manufacturer or responsible vendor, the plug shall also be marked with a catalogue number, type number or name, or other marking which will distinguish it from any other plug marketed by that manufacturer or responsible vendor.
- (e) Any IP rating, if claimed.

NOTE: Manufacturers making a statement of compliance with this Australian/New Zealand Standard on a product, packaging, or promotional material related to that product are advised to ensure that such compliance is capable of being verified.

2.12.2 Location of marking

The marking required by Clause 2.12.1 shall be located as follows:

- (a) Items (a) and (d)—on any portion of the plug.
- (b) Items (b), (c) and (e)—on the external body of the plug.

2.12.3 Additional requirements for rewirable plugs

A rewirable plug shall also be supplied with instructions detailing the following:

- (a) A diagram illustrating the method of connection of the conductors and, in particular, the earthing conductor and the cord anchorage. This diagram shall show the earthing conductor printed in green and yellow. The live conductors shall not be coloured.
- (b) A full-scale diagram showing the length of sleeving and insulation to be stripped back.
- (c) A description of the method of connection of each conductor giving the permissible alternative colours for the active, neutral and earthing conductors, respectively.
- (d) The size and types of flexible cords with which it is intended to be used.

NOTE: Plugs intended to be marketed in bulk, e.g. to equipment manufacturers, may be supplied with one set of instructions per package

2.12.4 Earthing connections

Where a rewirable plug incorporates a pin intended to provide an earthing facility, the pin shall be distinguished by marking in accordance with the requirements for the marking of earth connection of AS/NZS 3100 and located either on the pin or adjacent to the earthing terminal.

This marking shall be supplemented by the application of a conspicuous green colour on, or adjacent to, the earthing terminal, if the plug is of the rewirable type.

Where, during assembly, pins may become detached from the body of a plug yet remain attached to the conductors of a flexible cord, or are required to be detached from the body to enable connection, the above information shall be conspicuously marked on the earthing pin and on the body adjacent to the earthing pin position.

2.12.5 Live connections

2.12.5.1 General

The marking of live connections of rewirable plugs shall be as required by AS/NZS 3100, except that the active connection of plugs shall be indicated by the letter 'L', 'A' or 'P'. 'L' is the preferred letter.

2.12.5.2 Location of marking

Where pins may become detached from the body or are required to be detached to enable connection to the terminals, the marking shall be inside the body of the plug adjacent to the terminals.

In other cases, the marking may be on the terminals.

2.12.6 Configuration of plugs

A plug conforming to Figure 2.1(a), Figure 2.1(c), Figure 2.1(f) or Figure 2.1(g) shall have its pins disposed so that, when the pins are correctly connected, the pin configuration, viewed as from the pins, shall be earth, neutral and active in a clockwise direction.

Where there is no earthing pin, the live pins shall conform to this configuration.

2.13 TESTS ON PLUGS

2.13.1 General

Plugs shall be subjected to the tests specified in Table 2.2, carried out in the stated order, and shall comply with the requirements specified for each test.

2.13.2 Insulation resistance test

The insulation resistance of a plug shall be measured at a voltage of 500 V d.c. as follows:

- (a) Between all poles of the plug, taken in pairs.
- (b) Between live poles of the plug and any external metal, all live poles of the plug being connected together.
- (c) Between live poles of the plug and the earthing terminal of exposed metal, the live poles being connected together.
- (d) Between live poles and a flexible electrode applied to non-conducting parts normally handled in service all live poles connected together.
- (e) For insulated pin plugs, between live poles and a metal foil applied around the insulation on each live pin for a distance of approximately 4 mm from plug face, all live poles being connected together.

The measured insulation resistance shall be not less than 5 M Ω .

TABLE 2.2
PLUGS—TESTS TO BE APPLIED AND ORDER OF APPLICATION

1	2	3	4
Test No.	Description of test	Reference for test procedure and criteria ¹	Sample identification
—	General and dimensions	2 1 to 2 12	A
1	Insulation resistance test	2 13.2	A
2	High voltage test	2 13.3	A
3	Flexible cord anchorage test	2 13.4	A
4	Test of external nut or clamping ring	2.13.5	A
5	Screw threads and fixings	AS/NZS 3100	A
6	Attachment of covers	2 13.6	A
7	Mechanical strength of pin tests	2.13.7	
7a	Tumbling barrel test	2 13.7.1	BCD
7b	Pin bending test	2 13.7.2	EFG
8	Temperature rise test	2 13.8	H ²
9	Securement of pins	2 13.9	
9a	Movement of pins	2 13.9.1	I
9b	Fixing of pins	2 13.9.2	J
10	Determination of IP rating	2 13.10	K
11	Determination of ignitability and combustion propagation	2 13.11	any or L ³
12	Tests on non-rewireable plug and cord sets	2 13.12	
12a	Attachment of flexible cord	2 13.12.2	M
12b	Attachment of insulated cores	2 13.12.3	N
12c	Attachment of sheathing (sheathed cords)	2 13.12.4	O
12d	Attachment of insulation (unsheathed cords)	2 13.12.5	O
12e	Attachment of conductors	2 13.12.6	Q _u ⁴
13	Tests for plugs with insulated pins	2 13.13	
13a	Pressure test at high temperature	2 13.13.2	Pin _a ⁵
13b	Static damp heat test	2 13.13.3	R ⁶
13c	Low temperature test	2 13.13.4	S ⁶
13d	Impact test at low temperature	2 13.13.5	Pin _b ⁵
13e	Abrasion test	2.13.13.6	RS ⁶
Total number of samples required:			
Tests 1 to 9		10 (A, B, C, D, E, F, G, H, I, J)	
Test 10		1 (K)	
Test 11		1 (L, See Note 4)	
Test 12		4 (M, N, O and one unmoulded Q)	
Test 13		2 (R, S) plus 2 (Pin _a and Pin _b) insulated pins	

FOOTNOTES:

¹ Clause numbers refer to this Standard

² H is a special sample of a non-rewireable plug with terminal access for temperature rise

³ Resistance to fire test may require a further sample in new and clean condition

⁴ Q_u is an unmoulded sample

⁵ Pin_a and Pin_b are samples of separate insulated pins only.

⁶ The manufacturer may indicate that R and S are the same sample.

2.13.3 High voltage test

The plug shall withstand without failure an a.c. voltage of the value indicated in Table 2.3, applied between the parts set out in Items (a) and (c) of Clause 2.13.2 for 1 min in each case.

The plug shall further withstand, without failure, a voltage of 3500 V a.c. applied between the parts set out in Items (b) and (d) of Clause 2.13.2 for 1 min in each case.

The insulation of insulated pin plugs shall withstand a voltage of 1 250 V a.c. for 1 min applied in accordance with Clause 2.13.2(e).

TABLE 2.3
TEST VOLTAGES FOR HIGH VOLTAGE TEST

Working voltage (r.m.s.) between parts*		Testing voltage
	≤32 V	500 V
>32 V	≤250 V	1 000 V
>250 V	≤650 V	1 000 V + (2 × working voltage) with a maximum of 2 000 V

* For example, a plug for connection to a system operating at 415 V between phases and 240 V to earth would require a test of 1000 + (2 × 415) V between live terminals but only 1000 V between each live terminal and the earth terminal.

2.13.4 Flexible cord anchorage test

The cord anchorage and attachment of flexible cord and conductors of non-rewirable plugs shall be verified by application of the tests of Clause 2.13.12.

The cord anchorage test for rewirable plugs shall be carried out in accordance with the following test method.

The cord anchorage shall be tested with the conductors connected to the appropriate terminals. A direct pull of the values specified in column 4 of Table 2.4 shall be applied through the flexible cord in the direction in which it enters the plug. Over a period of 10 s, the pull shall be increased uniformly to the appropriate value, maintained at that value for a further 10 s, and then released. This test shall be performed three times.

The terminal screws of resilient and thermoplastic plugs shall be loosened as much as possible without removing the screws and a direct pull of the values specified in column 5 of Table 2.4 shall be applied through the flexible cord. Over a period of 10 s, the pull shall be increased gradually to the appropriate value, maintained at that value for a further 10 s, then released. This test shall be performed three times.

The number of cores in the flexible cord shall be appropriate to the number of pins of the plug. Notwithstanding column 3 of Table 2.4, if a plug has been designed to accommodate only a particular type of flexible cord in accordance with Clause 2.5, the plug shall be tested only with that cord; however, an entry hole of a size corresponding to the diameter of a particular type of circular flexible cord shall not be considered as restricting the use of the plug to that flexible cord.

The cord anchorage shall be considered inadequate if the flexible cord parts from the terminals, if the terminals break away or are impaired or, if during the test with the terminal screws loosened, the flexible cord moves longitudinally by 2 mm in the anchorage, either before the direct pull reaches the specified value or during the time that the pull is maintained.

TABLE 2.4
LOADS FOR CORD ANCHORAGE TEST

1	2	3	4	5
Plug rating	Flexible cord		Test force, N	
A	Size mm ²	Type	Conductors connected to terminals	Conductors connected; terminal screws loosened
≤3	0.5	Appropriate to design of plug	70 ±0.7	50 ±0.5
>3 ≤7.5	0.75	Appropriate to design of plug	110 ±1	50 ±0.5
>7.5 ≤10	0.75	Light duty* or ordinary duty		
>10 ≤15	1.0	Ordinary duty*		
>15	Next smaller size than maximum intended to be accommodated	Ordinary duty* or heavy duty if appropriate	110 ±1	65 ±0.7

* PVC insulated and sheathed.

2.13.5 Test of external nut or clamping ring

Plugs that incorporate an external nut or clamping ring as a means of cord anchorage shall be subjected to the following test:

A plug shall be wired with a minimum sized cord, as specified by the manufacturer, and an axial force of 110 N shall be applied to the external nut or clamping ring for 60 s and the external nut or clamping ring shall not become detached.

2.13.6 Attachment of covers

A plug with a removable cover, which is not secured by screws and which, when removed, exposes live parts, shall, together with the test equipment, be heated to a temperature of 50 ±2°C for 1 h and shall be maintained at that temperature throughout the test. The test shall be conducted without a cord attached to the plug.

The base of the plug shall be securely held in position. A force which, over a period of 10 s, shall be increased steadily to 60 ±0.6 N and held at this value for a further 10 s, shall be applied evenly at the neck of the plug in a direction parallel to the pins. This procedure shall be conducted three times on the same plug, at intervals of 5 min, without disturbing the cover between tests.

During the test period, the cover shall not separate from the base to enable live parts to be accessible to the standard test finger.

2.13.7 Mechanical strength of pin tests

2.13.7.1 *Tumbling barrel test*

Three plugs, not subjected to any previous tests, are tested in a tumbling barrel as described in AS 60068.2.32. Rewireable plugs are fitted with a flexible cord as specified in Table 2.1, having the smallest cross-sectional area of the lightest type and a length of approximately 100 mm, measured from the outer end of the guard (if any) or the plug.

Terminal screws and assembly screws are tightened with a torque equal to two-thirds of the torque specified in the test for screw threads and fixings of AS/NZS 3100.

Non-rewireable plugs are tested with the flexible cord as delivered, the cord being cut so that a free length of approximately 100 mm projects from the outer end of the guard or the plug (if any).

The samples are dropped from a height of 500 mm onto a steel plate, 3 mm thick. After each 100 drops the pins are inspected and straightened to pass through the gauge of Figure A1 or F1. The total number of falls shall be 1000.

The barrel is turned at a rate of 5 r/min, to yield 10 falls per minute. Only one sample is tested at a time.

After the test, the sample shall show no damage within the meaning of this Standard. In particular the following shall apply:

- (a) Live parts shall not have become exposed to the standard test finger.
- (b) For earth pins, the resistance of the plug/socket-outlet circuit shall be such that compliance with Clause 3.14.7 is maintained.
- (c) Any other function affecting safety shall not be impaired.
- (d) No live part shall have become detached or loosened, to the extent that a hazardous situation is created (see Clause 2.9).
- (e) The pins shall be inspected with normal, or corrected to normal, vision. Insulation may be removed if necessary. Pins shall not be broken or show cracking.

NOTES:

- 1 Special attention is paid to the connection of the flexible cord. Small pieces may be broken off without causing rejection, provided that the protection against electric shock is not affected.
- 2 Slight damage to the finish and small dents are neglected.
- 3 The specified free length of flexible cord of 100 mm may be reduced if the overall length of the plug and flexible cord approaches the width of the tumbling barrel test apparatus.
- 4 Tests to ascertain compliance with Items (a), (b) and (c) are conducted only in case of doubt.
- 5 Minor damage to plug pins is ignored

2.13.7.2 *Pin bending test*

All flat-pins of plugs rated up to and including 15 A shall be subjected to a pin bending test.

Three sample plugs not subjected to any previous tests shall be tested as follows:

Pins of assembled plugs shall be tested by clamping the plug in a rigid holding block and applying a bending force, as shown in Figure 2.8, to the pin under test.

The pins shall be straight at the beginning of the test. If there is any doubt about the straightness of the pin, it shall be checked by the appropriate plug gauge shown in Appendices A, B or F.

The point of application of the force shall be 14 ± 0.5 mm from the face of the plug.

The direction of the force shall be along a line parallel to the face of the plug.

Active and neutral pins shall be forced towards the centroid of the plug and then back to the starting point. Any earth pin shall be forced but in one direction only and then back to the starting point.

NOTE: This is intended to simulate damage that may occur when a plug is walked on and bent pins are straightened.

The distance moved from the point of application shall be 7.5 ± 0.3 mm, and then the pin shall be forced back to the starting point. Any 'spring-back' is ignored.

NOTE: 'Spring-back' means that the pin is allowed to move back to a position less than the travel distance, when the force is removed.

The travel from the starting point, to the end point (7.5 mm), and back to the starting point is one cycle (i.e. one cycle is two separate movements).

The speed of deflections shall be a maximum of 50 mm/s, without intentional delay between consecutive movements within each cycle.

The interval between successive cycles shall be a minimum of 10 s.

The duration of one cycle shall be a maximum of 60 s.

The pins shall be tested for 20 complete cycles.

After the tests the pins shall be inspected with normal or corrected to normal vision.

The pin shall not be broken off.

NOTE: Cracking of the pin, less than full thickness, is not deemed to be broken off.

If in doubt pins shall be disassembled from the plug and any insulation removed.

NOTE: In some cases the break may be below the face of the plug or the insulation may hold the broken pieces together, retaining electrical contact.

2.13.8 Temperature rise test

Plugs shall be so constructed that they comply with the following temperature rise test:

- (a) Non-rewireable plugs are tested as delivered (specially prepared sample with access to terminals for temperature measurement).
- (b) Rewireable plugs are fitted with polyvinyl chloride flexible cords with conductors having the minimum cross-sectional area specified in the manufacturers instructions.

The terminal screws or nuts are tightened with a torque equal to two-thirds of that specified in test No. 5.

NOTE: To ensure normal cooling of the terminals, the conductors connected to plugs should have a length of at least 1 m.

The test socket shall consist of a fixed socket outlet of a type complying with this Standard.

NOTE: In the case of a dispute, the test should be repeated using a new socket outlet.

The fixed socket outlet shall be mounted in an appropriate metal-wall box installed in a draught free position, and fitted with PVC insulated conductors at least 2.5 m long, having nominal cross-sectional areas as shown in Table 3.4.

The cables supplying the socket outlet shall be enclosed for a distance of 1 m in conduit terminated at the wall box.

The plug is inserted into the socket outlet and an alternating current of 1.1 times rated current is passed for 1 h.

The temperature of the flexible cord terminal is determined by means of melting particles, colour changing indicators or thermocouples, so chosen and positioned that they have negligible effect on the temperature being determined.

The temperature rise of the terminals shall not exceed 45 K.

2.13.9 Securement of pins

2.13.9.1 *Movement of pins*

Plugs shall be tested for pin movement by clamping the pin or pins not under test in a rigid holding block positioned 5 ± 0.5 mm from the plug face and applying a force of 18 ± 1 N to the pin under test. The design of the block shall be such that the pin under test shall not come into contact with the block during the test.

Except for non-rewireable plugs, the test shall be carried out without a cord attached to the plug, and with the terminal screws loosened sufficiently to allow a 1 mm^2 conductor to be connected.

The plug and test equipment shall be preconditioned at a temperature of $40 \pm 1^\circ\text{C}$ for 1 h, without the test force applied. Throughout the test, all parts of the plug and test equipment shall be maintained at this temperature.

For all plugs, the point of application of the force shall be 14 ± 0.5 mm from the face of the plug along the pins, and the direction of the force shall be—

- (a) in both directions along the line perpendicular to the plane of the pin, and passing through the centre of the pin; and
- (b) in that plane in both directions along a line at right angles to that specified in Item (a).

Over a period of 10 s, the force shall be gradually applied to each of the pins in the manner prescribed in Items (a) and (b), maintained at its maximum value for 10 s, and then released. The deflection of the pins shall be measured along the line of force relative to the face of the rigid holding block during the period when the force is applied. The maximum deflection shall not exceed 2.0 mm.

Following the test on all pins of a plug conforming to Figure 2.1, any distortion 5 min after the completion of the test on the last pin shall be such that it will not prevent the plug from being inserted in the appropriate standard gauges shown in Appendix A, Appendix B and Appendix F without the application of undue force.

For other types of plugs, any distortion after 5 min shall be such as will not prevent the plug being inserted into an appropriate socket-outlet without the application of undue force.

2.13.9.2 *Fixing of pins*

A separate sample of a plug shall be heated to a temperature of $50 \pm 2^\circ\text{C}$ for 1 h and maintained at that temperature during the whole of these tests, including the 5 min period after removal of the test load.

The plug shall be held firmly in such a manner that there will be no undue squeezing or distortion of the body, and the means of holding shall not assist in maintaining the pins in their original position.

Each pin, in turn, shall have applied to it a force which, over a period of 10 s, shall be increased steadily to 60 ± 0.6 N and held at this value for 10 min.

Two tests on each pin shall be conducted, one with the direction of force along the length of the pin towards the body of the plug, and the other with the direction of force along the length of the pin away from the body.

The attachment of pins shall be considered inadequate if any pin is displaced relative to the adjacent material of the body by more than 2.4 mm at any time during these tests, or if any pin fails to return to within 0.8 mm of its nominal length specified in Figure 2.1 within 5 min of the removal of the test force.

2.13.10 Determination of IP rating

The IP rating of a plug shall be determined with a socket-outlet nominated by the manufacturer and with any retaining device engaged. The assembly shall be tested to AS 60529.

Where a plug is to be tested to first characteristic numeral 5 of AS 60529 (dust test), testing shall be carried out under the conditions specified in AS 60529 for category 2.

2.13.11 Determination of ignitability and combustion propagation*

All insulating material shall be subjected to the glow-wire test specified in AS/NZS 60695.2 11 and the results determined in accordance with provisions thereof. The glow-wire shall be applied at a temperature of 650°C for 30 s.

2.13.11 Determination of ignitability and combustion propagation†

Plugs shall comply with the requirements for resistance to fire in accordance with AS/NZS 3100 Annex A. The glow-wire test temperature 'T' shall be 750°C.

2.13.12 Tests on non-rewirable plug and flexible cord

2.13.12.1 General

Non-rewirable plugs and flexible cords shall pass the tests in Clauses 2.13.12.2 to 2.13.12.6, except that only the test of Clause 2.13.12.5 shall be applied to flexible cords with tinsel conductors. Each of the tests is to be conducted on a separate sample.

For the purpose of these tests, the ambient temperature shall be maintained at $20 \pm 2^\circ\text{C}$.

2.13.12.2 Attachment of flexible cord

The flexing test shall be conducted according to the following procedures:

- (a) *Fixing the plug to the test apparatus* The plug shall be fixed by the pins in a rigid holding block to the oscillating member of the apparatus, as shown in Figure 2.2, so that when the member is in the middle of its travel, the axis of the flexible cord, where it enters the plug, is vertical and passes through the axis of oscillation. For the purpose of this test, any cord guard is considered to be part of the plug.

Plugs with flat cords shall be mounted so that the major axis of the section is parallel to the axis of oscillation.

The plug shall be positioned on the test apparatus so that when the member is oscillating, minimum lateral movement of the weight and cord occurs.

To obtain a mounting position with the minimum lateral movement of the weight and cord during a test, the apparatus should be constructed in such a manner that the different supports on the oscillatory member may be adjusted by a threaded spindle with a possible range of displacement of at least from 20 mm to 150 mm.

A device, e.g. a slot or a pin, should be used to check that the weight and cord assembly make minimum lateral movement.

- (b) *Loading of flexible cord* The cord shall be loaded with a mass such that the force applied is—
- (i) 20 ± 0.2 N for accessories with cables or cords having a nominal cross-sectional area exceeding 0.75 mm^2 ; or
 - (ii) 10 ± 0.1 N for accessories with flexible cords having a nominal cross-sectional area not exceeding 0.75 mm^2 .

* This Clause ceases to be part of the Standard on 9 July 2006

† This Clause forms part of the Standard on publication but shall be applied from 9 July 2006

The weight shall be positioned not less than 300 mm from the point at which the flexible cord enters the plug (see Figure 2.2).

- (c) *Test method* The oscillating member shall be moved through an angle of 90° (45° on either side of the vertical), the number of flexings being 10 000 and the rate of flexing 60 per min.

NOTE: A flexing is a movement in one direction.

Samples with circular section cables or cords are turned through 90° in the oscillating member after 5000 flexings. Samples with flat cords are bent only in a direction perpendicular to the plane containing the axis of the cores.

- (d) *Compliance during the flexing test* During the test, no strands shall pierce the insulation so that they become accessible.
- (e) *Compliance after the test* The criteria for compliance are the following:
- (i) The sample shall not show damage.
 - (ii) The protective sleeve, if any, shall not have separated from the body.
 - (iii) The insulation of the flexible cord shall not have been damaged.
 - (iv) Not more than 10% of the number of strands of each conductor shall have broken.

2.13.12.3 *Attachment of insulated cores*

The plug shall be rigidly held by the pins. A direct pull in the direction in which the flexible cord emerges from the plug shall be applied through the insulated cores clamped together at a point approximately 600 mm from the point of entry to the plug, with the sheathing (if any) being removed back to the plug. Over a period of 10 s, the pull shall be increased uniformly to 110 ± 1 N, maintained at the maximum value for a further 10 s, and then released.

The attachment of the insulated cores shall be considered inadequate if any core detaches from the plug, or if all conductor strands detach from a pin at any time during the test.

2.13.12.4 *Attachment of sheathing (sheathed cords)*

The plug shall be rigidly held by the pins. A direct pull in the direction in which the flexible cord emerges from the plug shall be applied through the sheathing only at a point approximately 600 mm from the point of entry to the plug, with the insulated cores and bedding being severed at a point approximately 25 mm from the plug. An axial slit shall be made in the sheathing for this purpose. Over a period of 10 s, the pull shall be increased uniformly to 130 ± 1.3 N, maintained at that value for a further 10 s, and then released.

The attachment for sheathing shall be considered inadequate if the insulated cores are exposed at the point of entry to the plug or the cord guard (if permanently attached to the plug), either before the direct pull reaches the required value or during the time that the pull is maintained.

For plugs attached to a light duty PVC or ordinary duty elastomeric flexible cord, the attachment shall be considered adequate if the insulated cores are not exposed at the point of entry when the sheathing breaks, if this occurs before the maximum force of 130 N is reached.

2.13.12.5 *Attachment of insulation (unsheathed cords)*

The plug shall be rigidly held by the pins. A direct pull in the direction in which the flexible cord emerges from the plug shall be applied to the cord at a point approximately 600 mm from the point of entry to the plug, with the insulation of each core being slit parallel to the conductor for a short distance at a point approximately 25 mm from the point of entry to the plug. All strands of the conductor and the separator (if any) shall be severed at the slit portion. Over a period of 10 s, the pull shall be increased uniformly to 65 ± 0.7 N, maintained at the maximum value for a period of 10 min, and then released.

The attachment of insulation shall be considered inadequate if the insulation detaches from the plug, or if the conductors are exposed at, or near, to the entry of the body, at any time during the test.

2.13.12.6 *Attachment of conductors*

The plug shall be cut open and the pins, together with a suitable length of the insulated cores, removed from the plug. Alternatively, the manufacturer may submit unmoulded samples for this test. Approximately 25 mm of the insulation adjacent to the plug pin shall be stripped from the cores. Each plug pin, in turn, shall be held rigidly and a direct pull applied to the conductor at a point approximately 600 mm from the pin in the direction in which the conductor is attached to the pin.

Over a period of 10 s, the pull shall be increased gradually to 85 ± 0.9 N, maintained at that value for a period of 1 min, and then released.

The attachment of conductors shall be considered inadequate if all conductor strands detach from the pin during any test.

2.13.13 Tests on the insulation material of insulated pin plugs

2.13.13.1 *General*

The material of the pin-insulation shall be resistant to the stresses to which it may be subjected at the high temperature likely to occur in conditions approaching the bad connection conditions and at low temperatures in particular conditions of service.

Compliance shall be checked by the tests of Clauses 2.13.13.2 to 2.13.13.6.

2.13.13.2 *Pressure test at high temperature*

A specimen of one insulated pin only shall be subjected to the following test by means of the apparatus shown in Figure 2.5. This apparatus shall have a blade having a round shape with a diameter of 6 mm and a thickness of 0.7 mm

The specimen shall be placed in position as shown in the Figure 2.5 and a force of 2.5 N shall be applied through the blade to the specimen.

The apparatus, with the specimen in position, shall be maintained for 2 h in a heating cabinet at a temperature of $160 \pm 5^\circ\text{C}$. The specimen shall then be removed from the apparatus and, within 10 s, cooled by immersion in cold water.

The thickness of the insulation shall be measured immediately at the point of impression.

The thickness of the insulation remaining at the point of impression shall be measured and shall not have been reduced by more than 50%.

Visual inspection shall be made and no cracks on the insulation material shall be visible with normal, or corrected to normal, vision without additional magnification, and the dimension of the insulating material shall not have changed below the minimum size shown in Figure 2.4.

2.13.13.3 *Static damp heat test*

An insulated pin plug shall be subjected to two damp heat cycles in accordance with AS 60068.2.30. Db (12 + 12 h cycle), 95% relative humidity, lower temperature $25 \pm 3^\circ\text{C}$ and upper temperature 40°C .

After this treatment and after recovery to room temperature, the specimen shall be subjected to—

- (a) the insulation resistance test in accordance with Clause 2.13.2(e); and
- (b) high voltage test in accordance with Clause 2.13.3; and
- (c) abrasion test in accordance with Clause 2.13.13.6.

NOTE: At the manufacturer's option, the same sample may be used for this test and the low temperature test (see Clause 2.13.13.4) and a single abrasion test may be done.

2.13.13.4 *Low temperature test*

An insulated pin plug shall be maintained at $-15 \pm 2^\circ\text{C}$ for at least 24 h and returned to room temperature.

The specimen shall be subjected to—

- (a) the insulation resistance test in accordance with Clause 2.13.2(e); and
- (b) high voltage test in accordance with Clause 2.13.3; and
- (c) abrasion test in accordance with Clause 2.13.13.6.

NOTE: At the manufacturer's option, the same sample may be used for this test and the static damp heat test (see Clause 2.13.13.3) and a single abrasion test may be done.

2.13.13.5 *Impact test at low temperature*

A specimen of one insulated pin only shall be subjected to an impact test by means of the apparatus shown in Figure 2.6. The mass of the falling weight shall be 100 ± 1 g.

The apparatus, on a sponge rubber pad 40 mm thick, together with the specimen, shall be maintained at $-15 \pm 2^\circ\text{C}$ for at least 24 h.

At the end of this period, the specimen shall be placed in position, as shown in Figure 2.6, and the falling weight shall be allowed to fall from a height of 100 mm. Four impacts shall be applied successively to the same specimen, rotating it through 90° between impacts.

After the test the specimen shall be allowed to return to room temperature and then examined. No cracks of the insulating material shall be visible with normal, or corrected to normal, vision without additional magnification.

NOTE: The cooling period of 24 h includes the time necessary to cool down the apparatus

2.13.13.6 *Abrasion test*

An insulated pin of an insulated pin plug shall be subjected to the following test by means of an apparatus as shown in Figure 2.7.

The test apparatus comprises a horizontally disposed beam, which shall be pivoted about its centre point. A short length of steel wire, 1 mm in diameter and bent into a U-shape, the base of the U being straight, shall be rigidly attached, at both ends, to one end of the beam, so that the straight part projects below the beam and shall be parallel to the axis of the beam pivot.

The plug shall be held in a suitable clamp in such a position that the straight part of the steel wire rests on the major axis face of the plug pin, at right angles to it. The pin shall slope downwards at an angle of 10° to the horizontal.

The beam shall be loaded so that the wire exerts a force of 4 N on the pin.

The plug shall be moved backwards and forwards in a horizontal direction in the plane of the axis of the beam, so that the wire rubs along the pin. The length of the pin thus abraded shall be approximately 9 mm, of which approximately 7 mm shall be over the insulation.

The number of movements shall be 20 000 (10 000 in each direction) and the rate of operation shall be 30 movements per min.

After the test, the pins shall show no damage which may affect safety or impair the further use of the plug, in particular, the insulating sleeve shall not have punctured or rucked up.

NOTES TO FIGURE 2 1:

- 1 For low voltage plugs, having ratings up to 15 A and of the Figure 2.1(a1), (c), (d), (f) or (g) type:
 - (a) If of the non-insulated pin type, it should comply with all dimensions including Figure 2.1(e).
 - (b) If of the insulated pin type, complying with Figure 2.4, and also complying with all other requirements of this Standard (e.g. Clause 2.8, 9 mm from live pins to the edge of plug mouldings), then other plug shapes are acceptable (e.g. oval 2-pin, triangular 3-pin). The $R20 \pm 1.0$ mm dimension of Figure 2.1(e) is not applicable, but the other dimensions of Figure 2.1(e) are still applicable to ensure they fit in the recess of Figure 3.5
- 2 The pin ends are shown as squared off for illustrative purposes only.
- 3 Attention is drawn to the requirements of Clause 3.6.2 and Notes 1 and 2 of Clause 3.6.3
- 4 The less than 21.9 mm and greater than 27 mm dimensions have been specified to allow side-by-side use, without jamming, of plugs and equipment with integral pins in adjacent socket-outlets if both are less than 21.9 mm, and to prevent improper use, such as jamming, if one, or both, are greater than 27 mm. This is based on the minimum 44 mm centre-to-centre distance between adjacent socket-outlets as required by Clause 3.6.2.

millimetres				
Dimension	≤10 A	15 A	20 A	Tolerance
A	6.35	6.35	9.08	±0.15
B	6.35	9.08	9.08	±0.15
C*	1.63	1.63	1.63	+0.15, -0.05
D	7.92	7.92	7.92	†
E	10.31	10.31	10.31	†
F	17.06	17.06	17.06	±0.4
G	19.94	19.94	19.94	±0.8
N	—	—	3.18	†
P	4.75	—	—	±0.05

millimetres		
Dimension	10 A	Tolerance
H	6.35	±0.15
L*	1.63	±0.15
J	6.35	†
K	17.06	±0.4
M	12.70	†

* Dimensions C and L apply to all pins

† Dimensions without tolerances are nominal. Samples are to be checked with the gauge specified in Appendix A, Appendix B or Appendix F, as appropriate

FIGURE 2 1 (in part) DIMENSIONS OF PLUGS

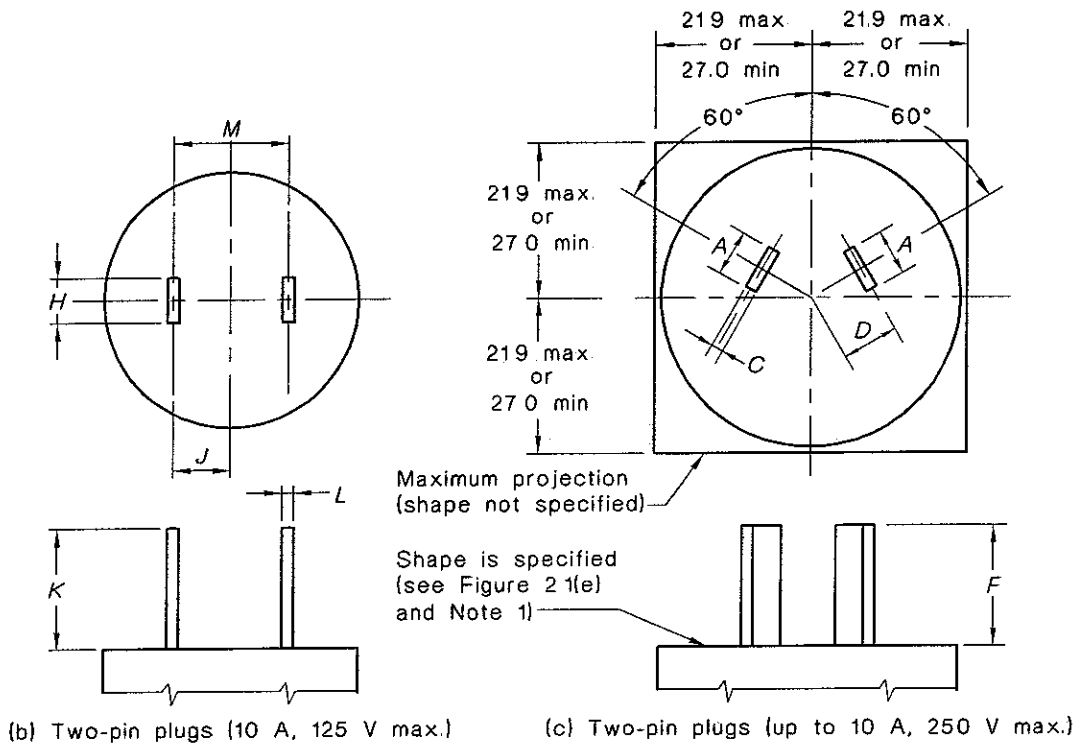
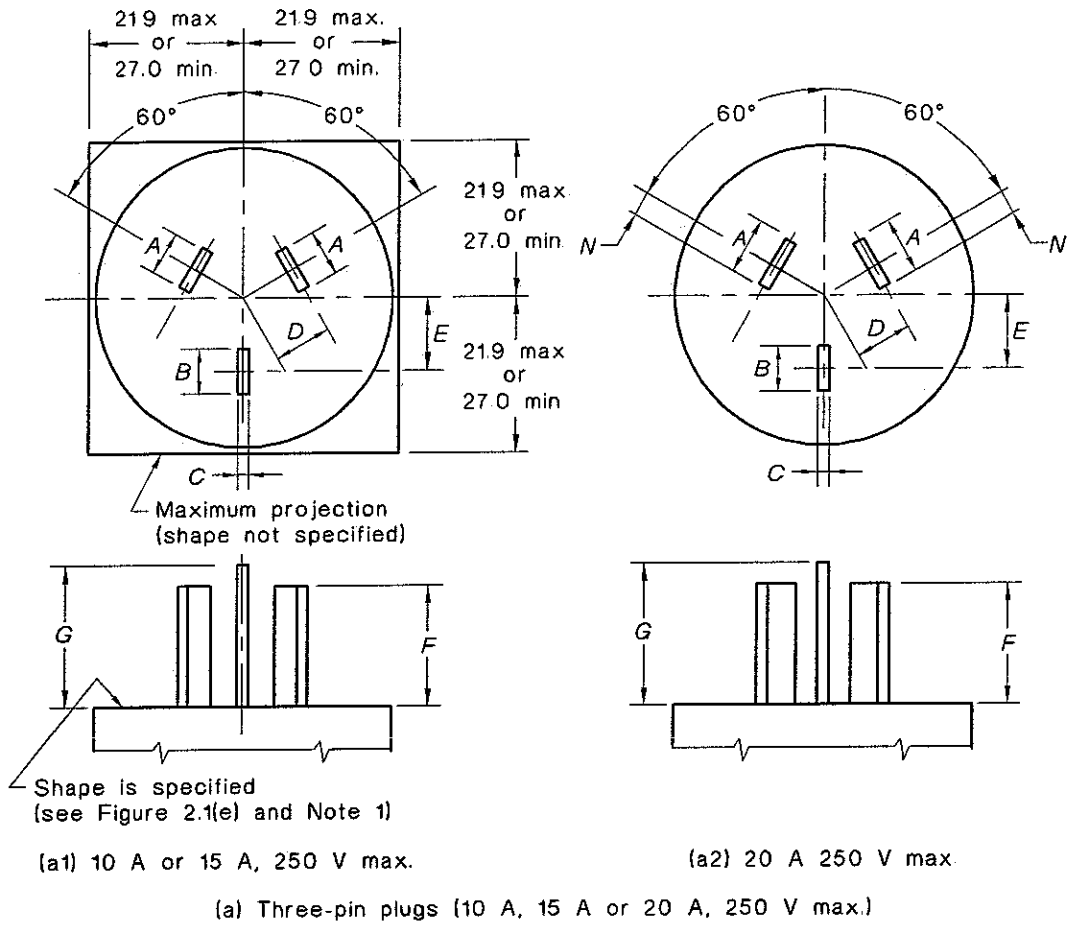

DIMENSIONS IN MILLIMETRES
 FIGURE 2.1 (in part) DIMENSIONS OF PLUGS

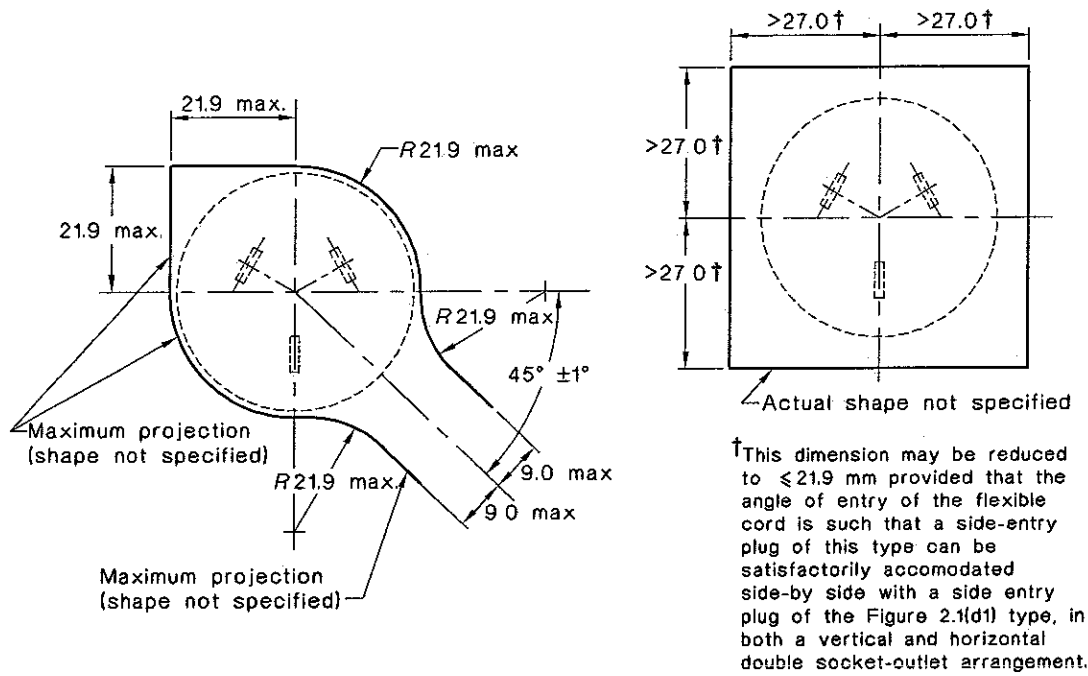

(d1) Side-entry plugs with a maximum projection of 219 mm (see Clause 2.5.2)

(d2) Side-entry plugs with a maximum projection greater than 270 mm (see Clause 2.5.2)

(d) Configuration of side-entry plugs (up to 15 A, 250 V max.)

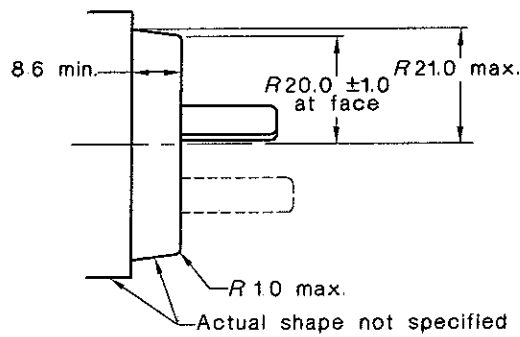

(e) Shape of plugs having ratings to 15 A, 250 V max. and of the (a1), (c), (d), (f) or (g) type

DIMENSIONS IN MILLIMETRES

FIGURE 2.1 (in part) DIMENSIONS OF PLUGS

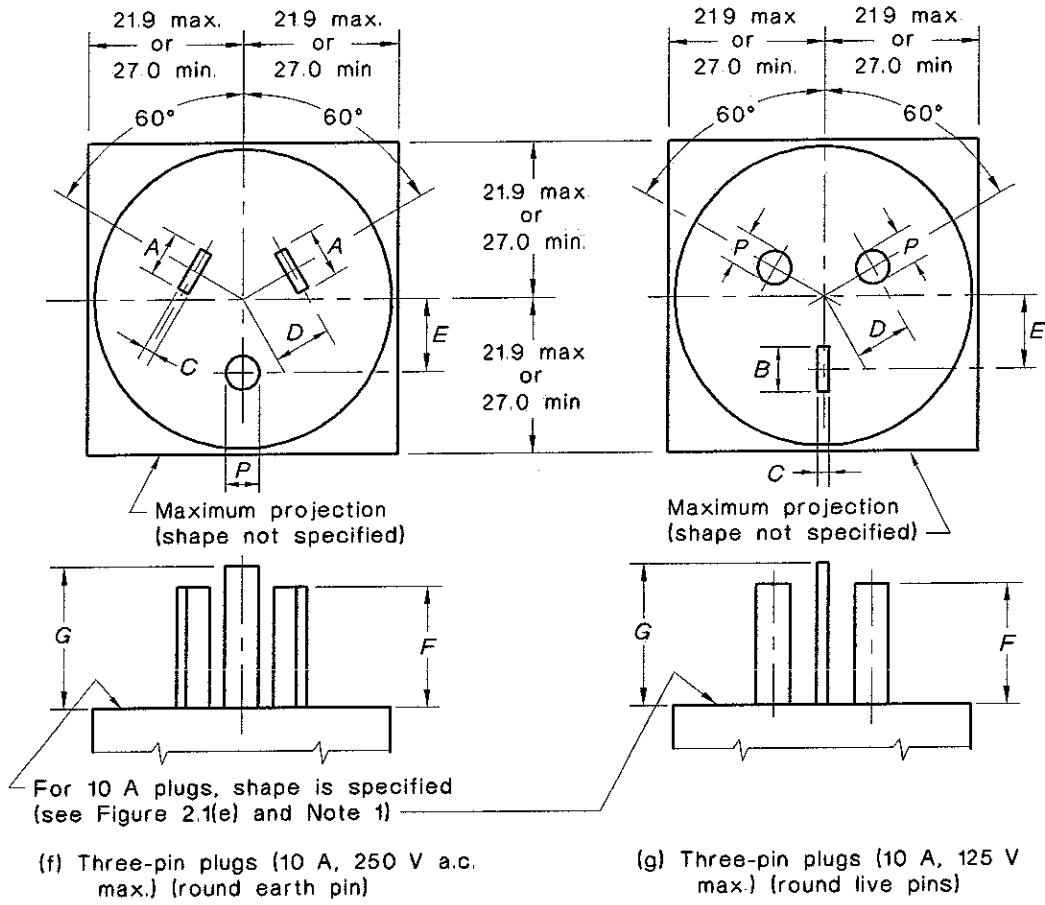

DIMENSIONS IN MILLIMETRES

FIGURE 2 1 (in part) DIMENSIONS OF PLUGS

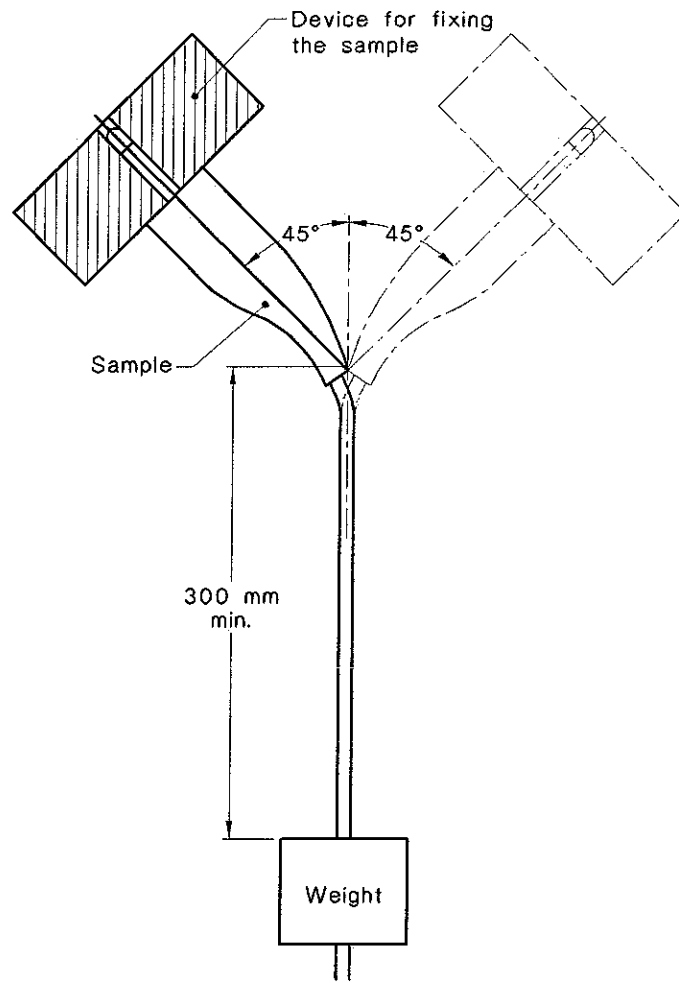

FIGURE 2 2 APPARATUS FOR FLEXING TEST

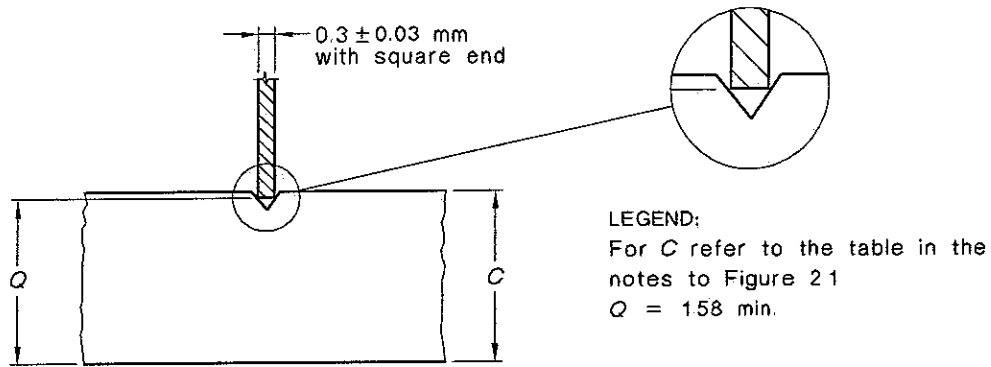

FIGURE 2.3 FORM OF PIN

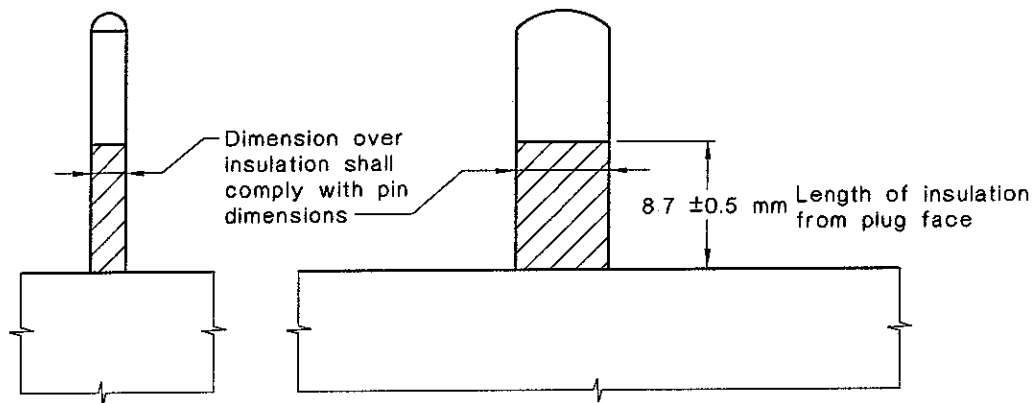
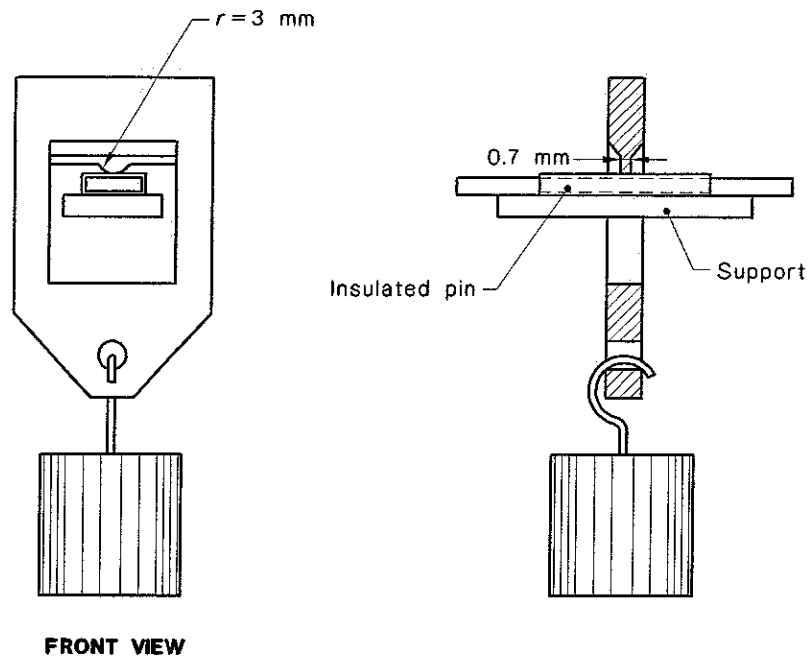

FIGURE 2.4 DIMENSIONS OF INSULATION ON INSULATED LIVE PINS



FRONT VIEW

DIMENSIONS IN MILLIMETRES

FIGURE 2.5 PRESSURE TEST APPARATUS FOR INSULATION ON INSULATED PLUG PINS AT HIGH TEMPERATURE

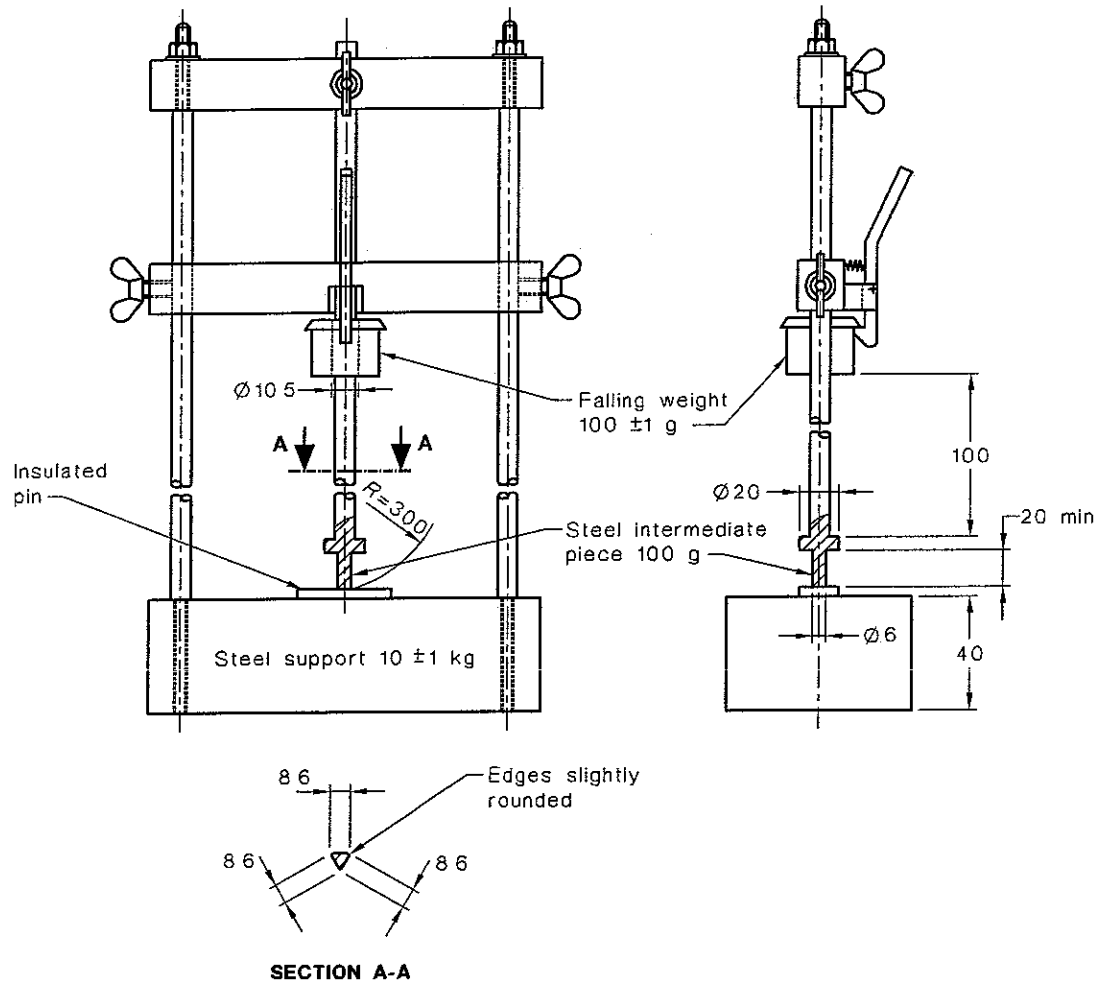

DIMENSIONS IN MILLIMETRES

FIGURE 26 IMPACT TEST APPARATUS FOR INSULATION ON INSULATED PLUG PINS AT LOW TEMPERATURE

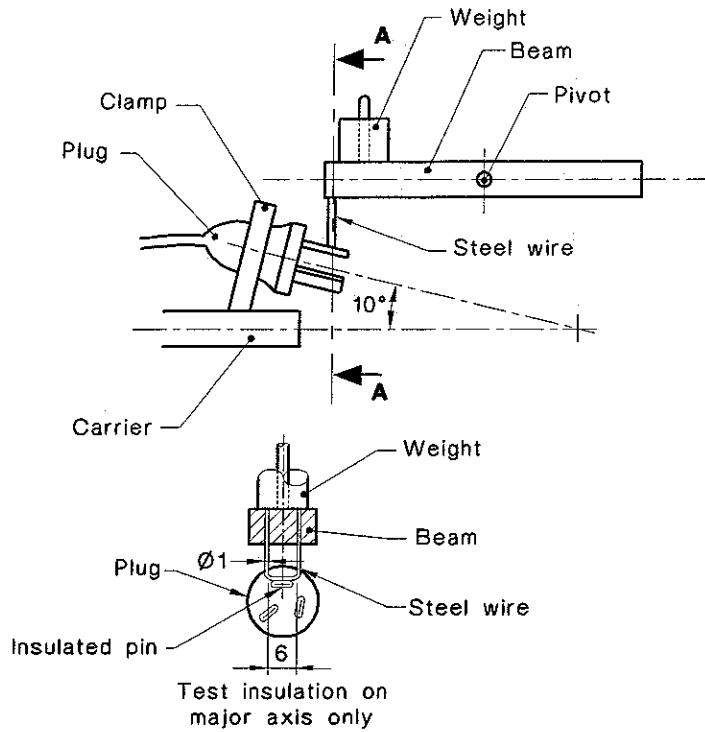

Enlarged part of section A-A showing steel wire

FIGURE 2.7 ABRASION TEST APPARATUS FOR INSULATION ON INSULATED PIN PLUGS

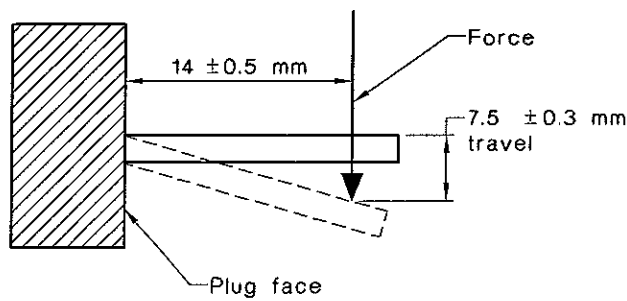

FIGURE 2.8 APPLICATION OF FORCE FOR PIN BENDING TEST

SECTION 3 SOCKET-OUTLETS

3.1 TERMINALS AND INTERNAL CONNECTIONS

3.1.1 Material

Terminals and internal connections intended primarily for carrying current shall be of a suitable corrosion-resisting metal having sufficient hardness and rigidity for the intended application.

3.1.2 Construction of terminals

The terminals of socket-outlets shall be recessed into the body of the socket-outlet so as to prevent accidental contact with bare earthing conductors or with other exposed metal.

Except in socket-outlets rated at 15 A or more, the live terminals of a socket-outlet shall be of suitable size and form to accommodate at least two conductors (for looping-in) of a size corresponding to the rating of the socket-outlet.

For all socket-outlets, earthing terminals shall be of suitable size and form to accommodate at least two earthing conductors of a size relative to the rating of the socket-outlets.

NOTE: Attention is drawn to AS/NZS 3000 regarding the minimum size of conductors permitted for wiring general-purpose outlets.

3.2 PROHIBITED ARRANGEMENTS

A low voltage fixed socket-outlet, or its faceplate, shall not incorporate a connecting device for telecommunications wiring, television or radio aerial wiring or other similar wiring systems.

3.3 SOCKET-OUTLET CONTACTS

3.3.1 Material

Contacts shall be of a corrosion-resisting metal having sufficient rigidity and durability for the intended application.

3.3.2 Construction

Contacts shall be such that they make and maintain, under normal service conditions, satisfactory electrical and mechanical contact with the pins of the appropriate type of plug. For socket-outlets intended to accommodate plugs with flat pins, contact shall be made with both sides of each pin, except that it shall be permissible to use spring-assisted single-sided contacts. These contacts shall not rely exclusively on the resilience of the contact material and shall have an opposite face of material other than thermoplastic or resilient insulating material.

The alignment and contact-making properties of contacts shall be independent of terminal screws.

The effectiveness of the contacts shall be independent of pressure from any thermoplastic or resilient moulding.

Compliance with the effectiveness of the contacts is checked by inspection and the following test:

A visual inspection is conducted to determine the existence of interference between the metal contacts and the thermoplastic or resilient moulding to provide supplementary contact pressure to the metal contacts.

If there is no visual evidence of interference the withdrawal force test is conducted on each socket contact in the assembly.

If interference exists, or if in doubt as to the existence of interference between the contact and the thermoplastic or resilient moulding the withdrawal force test is conducted on each socket contact where the assembly is modified by removing the suspected interfering material from around the contact, or an independent contact is removed from the assembly.

The withdrawal force of each socket contact shall be measured by a test pin gauge made of hardened steel, having surface roughness not exceeding $0.8 \mu\text{m}$ over its active length and dimensions of $6.20^{+0.02}$ mm width and a thickness of $1.58^{+0.02}$ mm.

The withdrawal force shall be not less than 1.5 N for ratings up to and including 10 A, 2 N for ratings above 10 A up to and including 15 A and 3 N for ratings above 15 A.

NOTE: The submitter may provide additional un-assembled contacts for the purpose of this test where required.

In socket-outlets designed for use with plugs complying with Figure 2.1, the contacts shall be self-adjusting in pitch and contact-making.

3.3.3 Entry or withdrawal of plug pins into a socket-outlet

Within the socket-outlet, there shall be provision for effective guidance of the corresponding plug pins to ensure direct entry and withdrawal without critical distortion of the socket-outlet contacts.

Compliance shall be checked by visual inspection and, if necessary, by a manual or electrical test.

3.3.4 Depth of contact

3.3.4.1 Depth of contact for socket apertures for flat pins

For socket-outlets having apertures intended to accommodate plugs having flat pins conforming to the dimensional requirements of Figure 2.1 the following tests shall be performed.

When the test gauge of Figure 3.1(a) or (b), as appropriate, is inserted into the socket-outlet live contact apertures in any possible manner, without undue force, contact with live parts shall not be possible.

When a metal blade of size —

- (a) $1.58^{+0}_{-0.02} \times 6.20^{+0}_{-0.05}$ mm for 10 A and 15 A socket-outlets; or
- (b) $1.58^{+0}_{-0.02} \times 8.93^{+0}_{-0.05}$ mm for 20 A socket-outlets;

is inserted, perpendicular to the socket-outlet face, into each and every aperture for flat pins, contact shall be made before a depth of 12.6 mm is reached.

In addition, the three-pin plug of Figure C1 of Appendix C or of Figure G1 of Appendix G, as appropriate, shall be capable of being fully inserted into a socket-outlet.

3.3.4.2 Depth of contact for socket apertures for round pins

For socket-outlets having apertures intended to accommodate plugs and having round pins conforming to the dimensional requirements of Figure 2.1, the following tests shall be performed.

When the test gauge of Figure 3.1(c) is inserted into the socket-outlet live contact apertures in any possible manner, without undue force, contact with live parts shall not be possible.

When a metal pin of diameter $4.70^{+0.05}$ is inserted, perpendicular to the socket-outlet face, into each and every round contact aperture, contact shall be made before a depth of 12.6 mm is reached.

In addition, one of the three-pin test plugs shown in Figure G1 of Appendix G shall be capable of being fully inserted into a socket-outlet.

3.4 INSULATING MATERIALS

The insulating portions of socket-outlets shall consist of—

- (a) a material having properties not inferior to those of Class 100 mouldings complying with AS/NZS 3121; or
- (b) ceramic material of a type such that, after immersion in water for 48 h and after all visible drops of water have been removed from the surface by means of a clean dry cloth, it shall not have increased in mass by more than 2%.

All insulating materials, except ceramics, shall further comply with the requirements of Clause 3.14.11. Thermoplastic escutcheon plates and faceplates associated with socket-outlets, which in normal service have any part positioned within 50 mm of live parts, shall be regarded as insulating materials for the purpose of this Clause. However this requirement is not applicable to decorative covers not required for the safe operation or installation of socket-outlets.

3.5 RADIO INTERFERENCE SUPPRESSORS

Where a capacitor is incorporated in a socket-outlet for the suppression of radio or television interference, the capacitor shall comply with IEC 60384-14.

3.6 DIMENSIONS

3.6.1 Pin entry apertures for plugs

Pin entry apertures in socket-outlets intended for use with plugs of the types shown in Figure 2.1 shall not exceed the dimensions specified in Table 3.1. These dimensions shall be checked by measurement.

The distance from the edge of the live pin aperture—

- (a) to the extremity of the socket-outlet face or faceplate shall be not less than 11.7 mm, except for 20 A rated socket-outlets, which shall be not less than 10.7 mm; or
NOTE: Within the 10.7 mm and 11.7 mm distance, any radius or shaping of the edges of the faceplate or socket-outlet face needs to be contained within a radius of 2 mm.
- (b) to the extremity of the faceplate, shall be not less than 13.7 mm and the maximum distance by which the faceplate, within the 13.7 mm distance specified, is below the plane of the surface surrounding the pin apertures, shall be 3 mm; and
NOTE: Any contouring or shaping of a faceplate or socket-outlet face within 13.7 mm from any edge of a live pin aperture, needs to be below the plane of the surface surrounding the pin apertures, but cannot be more than 3 mm below that plane.
- (c) to the nearest point of any metal faceplate shall be not less than 3 mm.
NOTE: Items (a) and (b) need not apply to fully recessed socket-outlets.

Figures 3.2 and 3.3 provide guidance with respect to the dimensional requirements of Items (a) and (b).

TABLE 3.1
MAXIMUM DIMENSIONS OF PIN ENTRY APERTURES

1	2	3	4	5	6
Socket-outlet rating A	Dimensions, mm				
	Flat live pin aperture		Flat earthing pin aperture		Round pin aperture
	Major axis	Minor axis	Major axis	Minor axis	
10	7.3	2.3	7.0	2.1	5.25
15	7.3	2.3	9.7	2.1	—
20	10.1	2.3	9.7	2.1	—

NOTE: Consideration has been given to the inclusion of a minimum dimension for the length of guide path for pin entry apertures, but this has not proved possible because of the limitations imposed by various designs of socket-outlets; however, it is recommended that manufacturers should design the pin entry apertures to provide the maximum possible length of guide path so as to assist in the prevention of contact distortion due to angular entry of plug pins

3.6.2 Spacing of socket-outlets

Where there is more than one socket-outlet, the centre-to-centre distance between adjacent socket-outlets shall be greater than 44 mm.

3.6.3 Socket-outlet faceplate

No part of the device, including any switch in any position, shall project more than 8.6 mm from the surface of the socket-outlet face within the shaded area of Figure 3.4. There shall be no projections in the area defined by R21.6 in Figure 3.4. This requirement applies to all socket-outlets except those with special design features, such as protection from dust, weather or mechanical damage.

NOTES:

- 1 This requirement allows for full insertion of a plug or plug-in device of the size indicated in Figure 2.1 and also prevents inadvertent or partial operation of any switch during insertion.
- 2 This requirement will not necessarily permit manual operation of any switch with the plug or plug-in device inserted.

3.6.4 Fully recessed socket-outlets

Where the face of a 10 A or 15 A socket-outlet for use with plugs complying with Figure 2.1(e) is fully recessed, the socket-outlet shall comply with Figure 3.5. Removable portions and breaks in the sidewall of the recess are not permitted. The socket face and recess sidewall shall form part of the fixed portion of the socket-outlet.

NOTE: This Clause only applies to socket-outlets which are claimed to be fully recessed socket-outlets.

3.6.5 Socket, IP-rated, with threaded retaining device

Where an IP-rated socket-outlet has an external thread, the dimensions of the thread shall comply with Appendix H, Figure H1(b). The Pitch Circle Diameter (PCD) on the socket shall be as shown in Appendix H, Figure H1(b).

3.7 ARRANGEMENT OF EARTHING CONNECTIONS

Where socket-outlets are provided with earthing connections, the design and construction shall be such that during normal insertion of the appropriate plug (see Clause 3.8.1), the earthing connection is made before the connection of the live pins and, during normal withdrawal, the earthing connection is broken after disconnection of the live pins.

The earthing pin aperture and contact of any low voltage socket-outlet, which is intended to accommodate a three-pin, flat-pin plug, shall be that aperture and contact that is radial to the circle embracing the pins (see Figure 2.1(a)).

3.8 PREVENTION OF CONTACT WITH LIVE PINS

NOTE: Fully recessed socket-outlets that comply with Clause 3.6.4 are considered to comply with Clauses 3.8.1 and 3.8.2

3.8.1 During normal insertion

At any stage during normal insertion of a non-insulated pin plug into a socket-outlet, with the faces of the plug and socket-outlet in parallel planes, it shall not be possible to touch, with the standard test finger (see AS/NZS 3100), a pin which may become alive.

Socket-outlets, for use with two-pin flat-pin plugs of the type shown in Figure 2.1(b), shall be checked for compliance with this requirement by means of an appropriate test plug having the minimum diameter of face and maximum length of live pins shown in Figure 2.1(b).

Socket-outlets for use with three-pin flat-pin plugs of the type shown in Figure 2.1(a) and Figure 2.1(d), and two-pin flat-pin plugs of the type shown in Figure 2.1(c) and Figure 2.1(d), shall be checked for compliance with this requirement by means of an appropriate test plug having the dimensions shown in Figure C1 of Appendix C.

Socket-outlets for use with three-pin plugs of the type having two flat live pins and one round earth pin, or two round live pins and one flat earth pin, as shown in Figure 2.1(f) and Figure 2.1(g), shall be checked for compliance with this requirement by means of the appropriate test plug having the dimensions shown in Figure G1(a) or G1(b) of Appendix G, respectively.

For socket-outlets with faceplates that are intended to be removed for interchangeability, this test shall be conducted with and without the faceplate in position.

3.8.2 During other than normal insertion

The design and construction of a socket-outlet shall be such that it is not possible for any pin of a plug with which the socket-outlet may appropriately be used to touch a live contact except during normal insertion, i.e. with each pin entering or adjacent to the aperture for the appropriate contact.

Socket-outlets for use with two-pin flat-pin plugs of the type shown in Figure 2.1(b) shall be checked for compliance with this requirement by means of an appropriate test plug having the minimum diameter of face and maximum length of live pins shown in Figure 2.1(b).

Socket-outlets for use with three-pin flat-pin plugs of the type shown in Figure 2.1(a) and Figure 2.1(d), and two-pin flat-pin plugs of the type shown in Figure 2.1(c) and Figure 2.1(d), shall be checked for compliance with this requirement by means of an appropriate test plug having the dimensions shown in Appendix D, Figure D1.

NOTE: This provision is intended to prevent the insertion of one pin of a plug while the other pin or pins are overhanging the socket-outlet, and to prevent the insertion of an earthing pin in a live contact.

For socket-outlets with faceplates that are intended to be removed for interchangeability, this test shall be conducted with and without the faceplate in position.

3.8.3 Alignment of faceplates

The socket-outlet shall incorporate positive means to preclude incorrect assembly and to ensure that the plug pin apertures in the socket-outlet faceplate will always be aligned with the appropriate contacts of the socket-outlet.

3.9 FUSES

A fuse shall not be incorporated in a socket-outlet.

3.10 FLOOR SOCKET-OUTLETS

Socket-outlets intended to be mounted in a floor shall be fitted with a strong hinged or sliding close-fitting cover of a material that is not combustible and that is capable of withstanding rough usage. The cover shall be fitted so that it will automatically close over the contacts when the plug is withdrawn from the socket-outlet and shall be arranged so that dust and water will be prevented from accumulating in the socket-outlet.

Compliance shall be checked by inspection.

3.11 SWITCHED SOCKET-OUTLETS

3.11.1 Socket-outlets switched by insertion of plug pins

Socket-outlets switched by insertion of plug pins shall be arranged and constructed so that—

- (a) the insertion of a plug into a socket-outlet shall cause the circuit to be made automatically (by means of a spring control or switch in the active conductor) after the engagement of the pins of the plug with the contacts of the socket-outlet;
- (b) the removal of a plug from a socket-outlet shall cause the circuit to be broken automatically (by means of a spring control or switch in the active conductor) prior to disengagement of the pins of the plug with the contacts of the socket-outlet;
- (c) any arc formed during the process of making or breaking the contacts shall be confined in such a way as to eliminate the risk of fire or shock; and
- (d) the contacts shall not be subject to damage from repeated use.

In addition to complying with this Standard, the switching function of socket-outlets switched by insertion of plug pins and intended for use with a plug complying with Figure 2.1(a), Figure 2.1(c) or Figure 2.1(d) shall comply with the requirements of Clause 3.11.2 except that the 'ON' position need not be indicated. Where two or more functions affect each other (such as the contact, switch and terminals of a socket-outlet arrangement switched by insertion of plug pins), the temperature rise applicable to each part shall not be exceeded.

NOTE: Should wearing of the pins of the test plug occur during this test, it is permissible to use another test plug(s)

3.11.2 Socket-outlet switches

Any switch intended for the control of a low voltage socket-outlet to be used with a plug complying with Figure 2.1(a), Figure 2.1(c) or Figure 2.1(d) shall comply with the relevant requirements of AS/NZS 3133. All switches provided shall be Category 2 switches and their 'ON' position shall be indicated in accordance with the requirements of AS/NZS 3100 for the visual indication of the positions of switches.

3.12 SHUTTERED SOCKET-OUTLETS

If a socket-outlet contains shutters, the shutters shall be activated by the neutral pin of a plug complying with Figure 2.1(c) so as to allow full insertion of this type of plug without undue force. Compliance is checked by inspection and manual test, if necessary.

3.13 MARKING

3.13.1 Required marking

Every socket-outlet shall be marked with the following information, in accordance with AS/NZS 3100:

- (a) The name, trade name, or mark of the manufacturer or of the responsible vendor.
- (b) The current rating in amperes.
- (c) The voltage.
- (d) If limited by any component to use on alternating current or direct current, the socket-outlet shall be marked 'a.c.' or 'd.c.' respectively.
- (e) If not the only type of socket-outlet marketed by the manufacturer or responsible vendor, the socket-outlet shall also be marked with a catalogue number, type number or name, or other marking which will distinguish it from any other type of socket-outlet marketed by the manufacturer or responsible vendor.
- (f) Any IP rating, if claimed.

NOTE: Manufacturers making a statement of compliance with this Australian/New Zealand Standard on a product, packaging, or promotional material related to that product are advised to ensure that such compliance is capable of being verified.

3.13.2 Location of marking

The marking required by Clause 3.13.1 shall be located as follows:

- (a) Items (a) and (d)—on any visible position of the socket-outlet or its cover.
- (b) Items (b), (c) and (f)—so that it is visible when the accessory is fixed in position and all covers are in place except that for socket-outlets intended to accommodate plugs having the dimensions specified in Figure 2.1, such markings may be inside the cover if the cover can be detached and replaced without removal of the socket-outlet when it is mounted in position.
- (c) Item (e)—on the socket-outlet or on a securely attached label, or on the container in which the socket-outlet is marketed.

3.13.3 Earthing connections

Where a socket-outlet incorporates a contact intended to provide an earthing facility, its terminal shall be distinguished by marking, in accordance with the requirements of AS/NZS 3100, for the marking of earth connections located either on, or adjacent to, the earthing terminal.

3.13.4 Live connections

The live connections of socket-outlets designed to accept plugs that conform to Figure 2.1(a), Figure 2.1(c) and Figure 2.1(d) shall be marked either on or adjacent to the terminals, and shall comply with the requirements of AS/NZS 3100 for the marking of live supply connections, except that the active terminal of socket-outlets intended for use with flat-pin plugs shall be indicated by the letter 'A', 'L' or 'P'. 'L' is the preferred letter.

The marking shall correspond to the socket-outlet contacts being in the order of earth, active and neutral in a clockwise direction when viewed from the front of the socket-outlet.

3.14 TESTS FOR SOCKET-OUTLETS

3.14.1 General

Socket-outlets shall be subjected to the tests specified in Table 3.2, carried out in the stated order, and shall comply with the requirements specified for each test. Where required by these tests, the socket-outlet shall be tested in conjunction with an appropriate plug which complies with this Standard.

TABLE 3.2*
SOCKET-OUTLETS—TESTS TO BE APPLIED
AND ORDER OF APPLICATION

1	2	3	4
Test No.	Description of test	Reference for test procedure and criteria ¹	Sample identification
—	General and dimensions	3 1 to 3 13	A
1	Insulation resistance test No. 1	3 14.2	A
2	High voltage test	3 14.3	A
3	Screw threads and fixings	AS/NZS 3100	A
4	Current breaking test	3 14.4	AB ²
5	Temperature rise test	3 14.5	A
6	Insulation resistance test No. 2	3 14.6	A
7	Test of earthing connection	3 14.7	A
8	Strength of contact tests	3 14.8	CDE
9	Switch test	3 14.9	DF
10	Determination of IP rating	3 14.10	D
11	Determination of ignitability and combustion propagation	3 14.11	any or G ³
Total number of samples required:			5/6/7

NOTES:

¹ Clause numbers refer to this Standard

² Two samples are required if both a.c. and d.c. ratings are required

³ Ignitability and combustion propagation testing may require a further sample in new and clean condition

* This Table ceases to be part of the Standard 6 months after publication

TABLE 3.2*
**SOCKET-OUTLETS—TESTS TO BE APPLIED
AND ORDER OF APPLICATION**

1	2	3	4
Test No.	Description of test	Reference for test procedure and criteria ¹	Sample identification
–	General and dimensions	3 1 to 3 13	A
1	Insulation resistance test No 1	3 14 2	A
2	High voltage test	3 14 3	A
3	Screw threads and fixings	AS/NZS 3100	A
4	Current breaking test	3 14 4	AB ²
5	Temperature rise test	3 14 5	A
6	Insulation resistance test No 2	3 14 6	A
7	Test of earthing connection	3 14 7	A
8	Test of lateral strain	3 14 8.1	CDE FGH
9	Withdrawal force test	3 14 8 2	CDE FGH
10	Switch test	3 14 9	DI
11	Determination of IP rating	3 14 10	D
12	Determination of ignitability and combustion propagation	3 14 11	any or J ³
Total number of samples required:			8/9 ² /10 ³

FOOTNOTES:

¹ Clause numbers refer to this Standard.

² Two samples are required if both a.c. and d.c. ratings are required.

³ Ignitability and combustion propagation testing may require a further sample in new and clean condition.

3.14.2 Insulation resistance test No. 1

The insulation resistance of a socket-outlet shall be measured at a voltage of 500 V d.c. with the socket-outlet fitted with an appropriate plug, as follows:

- (a) Between live terminals of the socket-outlet with the plug open-circuited.
- (b) Between live terminals of the socket-outlet and any metal part which would be exposed when the socket-outlet is mounted in position, with the live terminals of the plug being connected together. This test shall be made with all exposed metal parts bonded together.
- (c) Between live terminals of the socket-outlet and a metal support with the live terminals of the plug being connected together. For the purpose of this test the socket-outlet shall be mounted, using the fixing holes provided, on a metal plate by means of metal fixing screws corresponding in respect of their diameter and size and type of head with the screws which would normally be used for fixing the socket-outlet.

The metal support shall duplicate the normal mounting enclosure or bracket, with the mounting position taking into account any variation in spacings due to wall thickness and any movement of the socket-outlet within its mountings.

* This Table forms part of the Standard on publication but shall be applied 6 months after publication

NOTE: A suitable metallic enclosure for socket-outlets on mounting plates of approximately H 114 mm × W 72 mm with 84 mm centres is one of H 90 mm × W 60 mm × D 40 mm (approximating dimensions of commonly available units).

- (d) Between live terminals of the socket-outlet and the earthing terminal (if any), with the live terminals of the plug being connected together.
- (e) Between live terminals of the socket-outlet and a flexible electrode applied to non-conducting parts normally accessible in service, including insulated heads of screws.

The insulation resistance so measured shall be not less than 5 MΩ.

3.14.3 High voltage test

The socket-outlet shall withstand, without failure, an a.c. voltage of the value indicated in Table 3.3 applied between the parts set out in Items (a) and (c) of Clause 3.14.2 for 1 min in each case. The socket-outlet shall further withstand, without failure, a voltage of 3500 V a.c. applied between the parts set out in Items (b) and (d) of Clause 3.14.2 for 1 min in each case. The socket-outlet shall be fitted with an appropriate plug during the test.

TABLE 3.3
TEST VOLTAGES FOR HIGH VOLTAGE TEST

Working voltage (r.m.s.) between parts (See Note)	Testing voltage
≤ 32 V	500 V
> 32 V ≤ 250 V	1 000 V
> 250 V ≤ 650 V	1 000 V + (2 × working voltage) with a maximum of 2000 V

NOTE: For example, a socket-outlet for connection to a system operating at 415 V between phases and 240 V to earth, would require a test of 1000 + (2 × 415) V between live terminals but a test of only 1000 V between live parts and earth

3.14.4 Current breaking test

With the exception of interlocked socket-outlets and socket-outlets switched by insertion of plug pins complying with Clause 3.11, socket-outlets shall be subjected to the test set out in this Clause.

Socket-outlets shall be tested using a test plug with brass pins having dimensions complying with this Standard.

The plug shall be inserted into, and withdrawn from, the socket-outlet 50 times (100 strokes) at a rate of 150 mm/s and 30 strokes per minute.

NOTE: A stroke is an insertion or a withdrawal of the plug.

The test voltage shall be 1.06 times the rated voltage and the test current shall be 1.25 times the rated current.

The test current shall be a.c. with a power factor of approximately 0.75 lagging, or d.c., as appropriate. Where a socket-outlet is intended for both a.c. and d.c. operation, a separate sample shall be tested on each source of supply.

No current shall be passed through the earthing circuit, if any such circuit exists.

The socket-outlet and plug shall be mounted so that the withdrawal movement is in an approximately horizontal direction, and the earthing pin, if any, is at the lowest point.

An appropriate type of plug, complying with this Standard and having a rating corresponding to that of the socket-outlet, shall be used for this test.

During the test, no sustained arcing shall occur.

After the test, the samples shall show no damage impairing their further use and the entry holes for the pins shall show no damage that may impair the safety of the socket-outlets.

3.14.5 Test of temperature rise

Socket-outlets shall be tested using a test plug with brass pins having the specified dimensions of Figure 2.1. The plug shall be inserted into the socket-outlet and 1.1 times rated current shall be passed until a constant temperature has been attained. The temperature shall be determined by means that have a negligible effect on the temperature being determined. For multi-outlet socket-outlet units, the test shall be conducted on one outlet of each type, the outlet(s) not under test being maintained in a no-load condition.

For the purpose of this test, the connecting cables shall be unsheathed Type V75 cables, the size of which shall be determined from Table 3.4. Plugs shall have at least 1 m of cable and socket-outlets shall have at least 2.5 m of cable. The cables shall be stripped to the minimum length required to effect the intended connection of the socket-outlet. The socket-outlet shall be mounted in an appropriate metal wall box installed in a draught-free position, and the cables supplying the socket-outlet shall be enclosed for a distance of 1 m in conduit terminated at the wall box. The terminal screws or nuts shall be tightened with a torque equal to two-thirds of that specified in the test for screw threads and fixings in AS/NZS 3100.

The temperature rise of any terminal or contact shall not exceed 45 K.

For the purpose of this test, the ambient temperature shall be maintained at $20 \pm 5^\circ\text{C}$.

TABLE 3.4
SIZE OF CABLES FOR TEST OF TEMPERATURE RISE

Rated current of accessory <i>A</i>	Nominal cross-section area mm^2	
	Flexible conductors for portable accessories	Rigid conductors (solid or stranded) for fixed accessories
≤ 10	1	1.5
$> 10 \leq 16$	1.5	2.5
$> 16 \leq 20$	2.5	2.5
$> 20 \leq 32$	4	4

3.14.6 Insulation resistance test No. 2

The insulation resistance test specified in Clause 3.14.2 shall be repeated. The insulation resistance measured shall be not less than 5 M Ω .

3.14.7 Test of earthing connection

The resistance between the earthing terminal of any socket-outlet provided with an earthing contact and the earthing terminal of the plug used for testing shall be of a low resistance. The earthing connections shall be tested in accordance with AS/NZS 3100.

3.14.8 Strength of contact tests

3.14.8.1 *Test of lateral strain**

Socket outlets rated up to and including 10 A, and intended to be used with plugs of the Figure 2.1 (a1) type, shall withstand the lateral strain imposed by equipment likely to be introduced into them.

Compliance shall be checked by means of the device shown in Figure 3.6 and shall be applied to three socket outlets not subjected to any previous test of this Standard. Each specimen shall be mounted on a vertical surface with the plane through the socket contacts horizontal. The device shall be then fully engaged and a weight hung on it such that the force exerted is 5 N.

The device shall be removed after 1 min and the socket outlet shall be turned through 90° on the mounting surface. The test shall be made 4 times, the socket outlet being turned 90° after each engagement.

During the test, the device shall not come out.

After the tests, the socket-outlets shall show no damage within the meaning of this Standard and, in particular, they shall comply with the requirements of Clause 3.14.8.2.

In addition, the withdrawal force of each socket contact shall be measured by a test pin gauge made of hardened steel, having surface roughness not exceeding 0.8 µm over its active length and dimensions of 6.20^{+0.02} mm width and a thickness of 1.58^{+0.02} mm. The withdrawal force shall be not less than 1.5 N.

Shutters, if any, shall be rendered inoperative so as not to affect the test.

3.14.8.1 *Test of lateral strain†*

Socket-outlets rated up to and including 10 A, and intended to be used with plugs of the Figure 2.1(a1) type or Figure 2.1(c) type, shall withstand the lateral strain imposed by equipment likely to be introduced into them.

Socket-outlets for use with plugs of the Figure 2.1(a1) type shall be tested by the application of the gauge shown in Figure 3.6 and Figure 3.7 and socket-outlets for use only with plugs of the Figure 2.1(c) type shall be tested by the application of the gauge shown in Figure 3.7 as follows:

- (a) *Application of test gauges* The gauge shown in Figure 3.6 shall be applied to three socket-outlets not subjected to any previous test of this Standard. The gauge shown in Figure 3.7 shall be applied to three socket-outlets not subjected to any previous test of this Standard.
- (b) *Test procedure* Each specimen shall be mounted on a vertical surface with the plane through the socket contacts horizontal. The gauge shall be then fully engaged and a weight hung on it such that the force exerted is 5 N.

The gauge shall be removed after 1 min and the socket-outlet shall be turned through 90° on the mounting surface. The test shall be made once in each of the following positions: 0°; 90°; 180°; 270°.

During the test, the gauge shall not come out.

After the tests, the socket-outlets shall show no damage within the meaning of this Standard and, in particular, they shall comply with the requirements of Clause 3.14.8.2.

* This Clause ceases to be part of the Standard 6 months after publication.

† This Clause forms part of the Standard on publication but shall be applied 6 months after publication

In addition, the withdrawal force of each socket contact that has been subject to the above tests shall be measured by a test pin gauge made of hardened steel, having surface roughness not exceeding $0.8 \mu\text{m}$ over its active length and dimensions of $6.20_{-0.02}^{+0.02}$ mm width and a thickness of $1.58_{-0.02}^{+0.02}$ mm. The withdrawal force shall be not less than 1.5 N.

Shutters, if any, shall be rendered inoperative so as not to affect the test.

3.14.8.2 *Withdrawal force test*

This test is applicable only to socket-outlets rated at up to and including 10 A, and intended for use with plugs of the type shown in Figure 2.1(a1). The test shall be applied to the three socket-outlets subjected to the tests of Clause 3.14.8.1.*

This test is applicable only to socket-outlets rated at up to and including 10 A, and intended for use with plugs of the type shown in Figure 2.1(a1). The test shall be applied to all the socket-outlets subjected to the test of Clause 3.14.8.1.†

Plugs rated at 10 A and complying with Figure 2.1(a1) of this Standard and which have not been subjected to any previous tests shall be used. A separate plug shall be used for testing each socket-outlet.

Manually insert the plug fully into and withdraw it from the socket-outlet 10 times.

Manually align the plug in the socket-outlet to minimize the effects of misalignment between mating components and any other friction-increasing factors, so as to attain the best practical position for minimum resistance to withdrawal.

NOTE: When testing in other than the horizontal plane, the mass of the plug and socket-outlet is to be considered in all measurements

The plug is then fully reinserted and a withdrawal force gradually applied by any suitable means until the plug is fully withdrawn. The withdrawal force, during three subsequent and consecutive disengagements, shall be measured.

The withdrawal forces so measured shall be between 20 N and 50 N.

3.14.9 **Switch test**

Where a switch is combined with a socket-outlet, separate samples shall be used for testing the switch in accordance with AS/NZS 3133. The terminals of the switch-socket-outlet combination (as used in service) shall be used for the connection of cables as required by the tests in this Standard and in AS/NZS 3133.

In addition, the switch shall pass the test for motor control switches of AS/NZS 3133, using the following test currents:

- | | | |
|-----|-------------------------------|-------|
| (a) | For 10 A socket-outlets | 40 A. |
| (b) | For 15 A socket-outlets | 50 A. |
| (c) | For 20 A socket-outlets | 63 A. |

3.14.10 **Determination of IP rating**

The IP rating of a socket-outlet shall be determined by the following two test conditions:

- The socket-outlet with a plug as nominated by the manufacturer inserted and with any retaining device engaged.
- The socket-outlet with its associated cover engaged, or for spring loaded flaps, with the associated flap being released from 90° to the plug engagement face.

The IP ratings of both assemblies shall be determined by the tests of AS 60529.

* This Paragraph ceases to be part of the Standard 6 months after publication

† This Paragraph forms part of the Standard on publication but shall be applied 6 months after publication

Where a socket-outlet is to be tested to first characteristic numeral 5 of AS 60529 (dust test), testing shall be carried out under the conditions specified in AS 60529 for category 2.

3.14.11 Determination of ignitability and combustion propagation*

All insulating material shall be subjected to the glow-wire test specified in AS/NZS 60695.2.11 and the results determined in accordance with provisions thereof. The glow-wire shall be applied for 30 s at a temperature of—

- (a) 750°C for fixed socket-outlets; and
- (b) 650°C for other socket-outlets.

3.14.11 Determination of ignitability and combustion propagation†

Socket-outlets shall comply with the requirements for resistance to fire in accordance with AS/NZS 3100 Annex A as follows:

- (a) The glow-wire test temperature 'T' shall be—
 - (i) 750°C for fixed socket-outlets; and
 - (ii) 650°C for other socket-outlets.
- (b) All other relevant parts of fixed socket-outlets shall be subjected to the glow-wire test with a test temperature of 750°C.

However, for parts in contact with current-carrying parts, there shall be no flaming during the test but disregarding the first 5 s.

* This clause ceases to be part of the Standard on 9 July 2006

† This clause forms part of the Standard on publication but shall be applied from 9 July 2006.

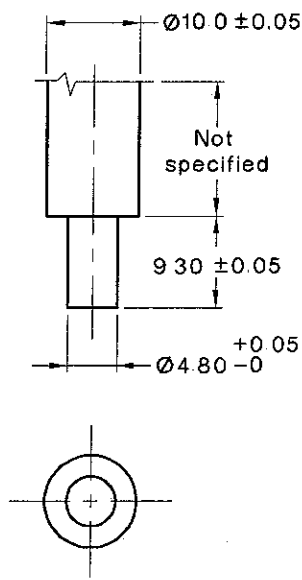
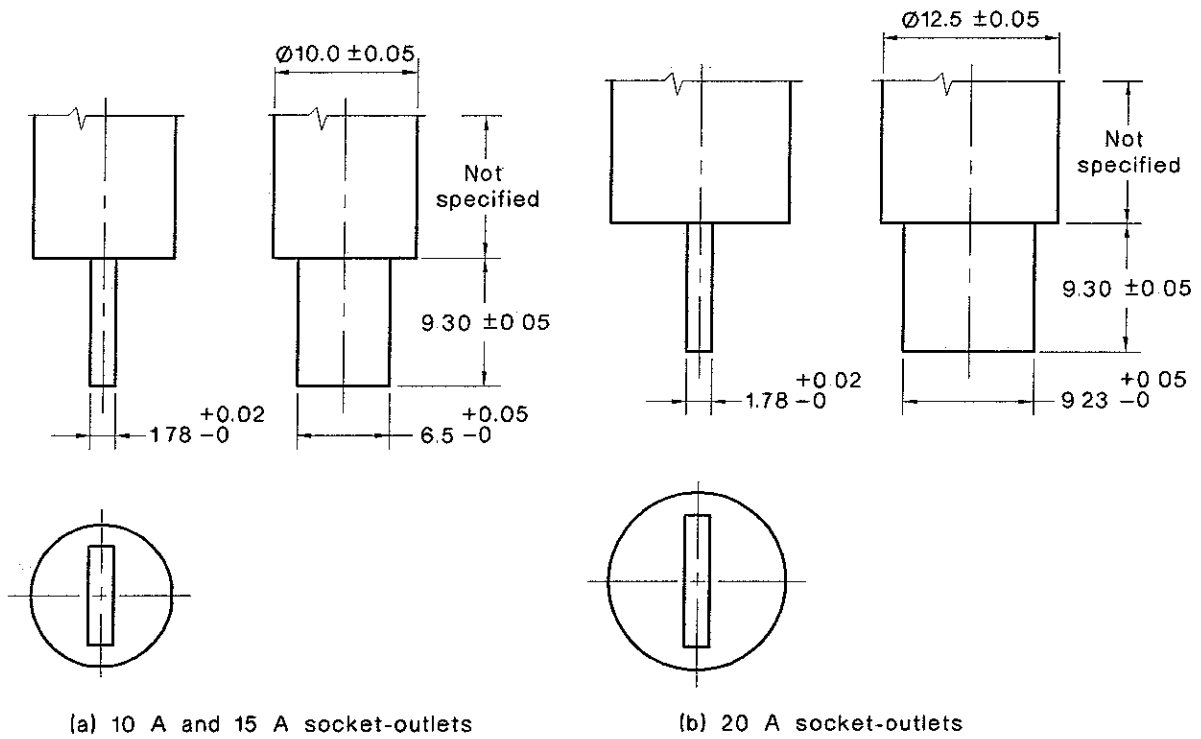

NOTE: All sharp edges may have a radius of 0.1 mm maximum

DIMENSIONS IN MILLIMETRES

FIGURE 3.1 GAUGE FOR DEPTH OF NO-CONTACT TEST

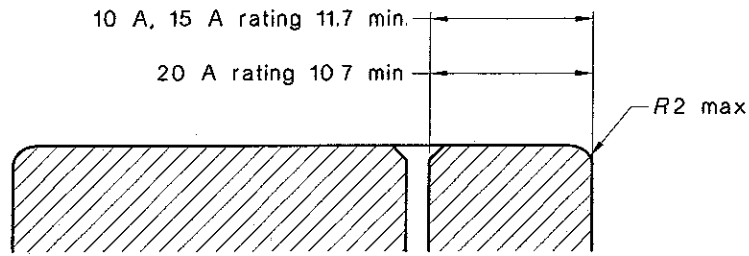

DIMENSIONS IN MILLIMETRES

FIGURE 3.2 SOCKET-OUTLET FACE PROFILE IN ACCORDANCE WITH CLAUSE 3.6.1 ITEM (a)

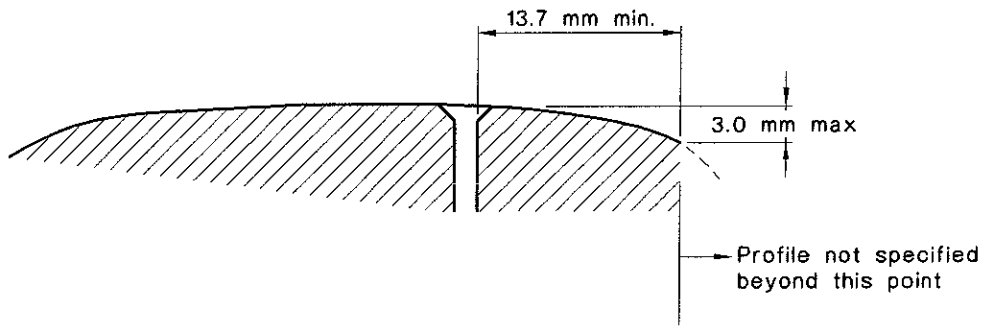

DIMENSIONS IN MILLIMETRES

FIGURE 3.3 SOCKET-OUTLET FACE PROFILE IN ACCORDANCE WITH CLAUSE 3.6.1 ITEM (b)

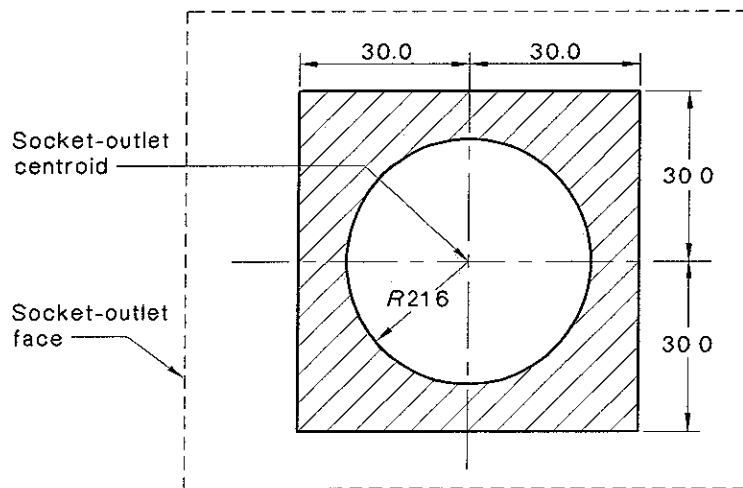

DIMENSIONS IN MILLIMETRES

FIGURE 3.4 AREA OF LIMITED PROJECTION

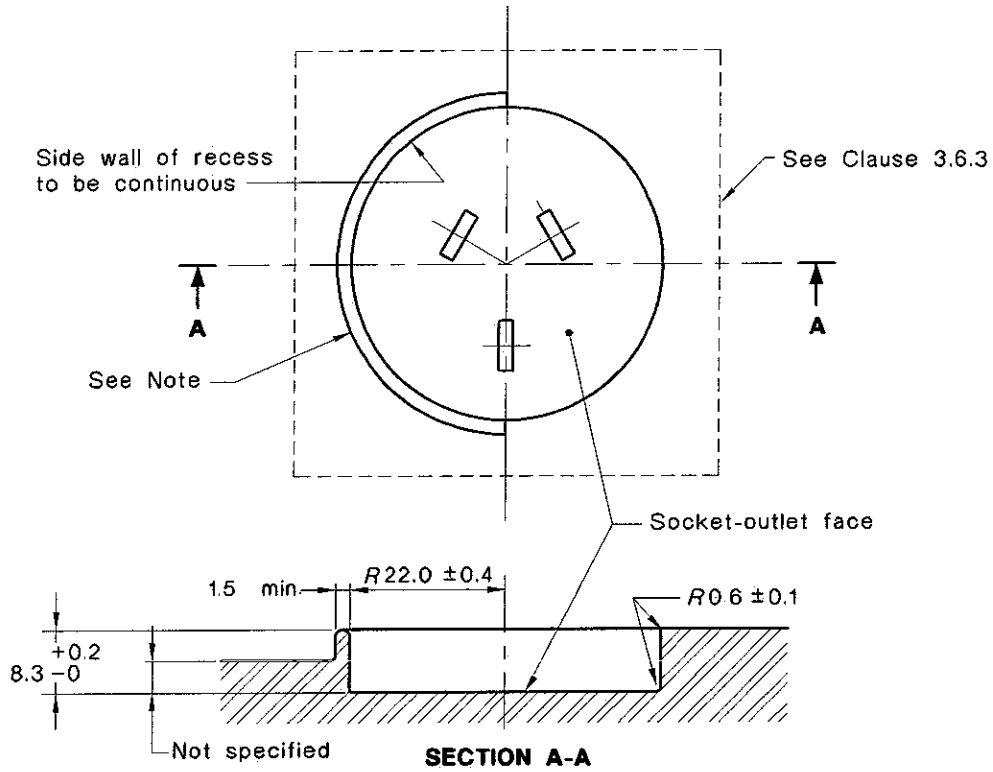

NOTE: A fully recessed socket-outlet may be recessed or provided with a rim over part or all of the perimeter. The example depicted shows half and half.

DIMENSIONS IN MILLIMETRES

FIGURE 3.5 FULLY RECESSED SOCKET-OUTLET

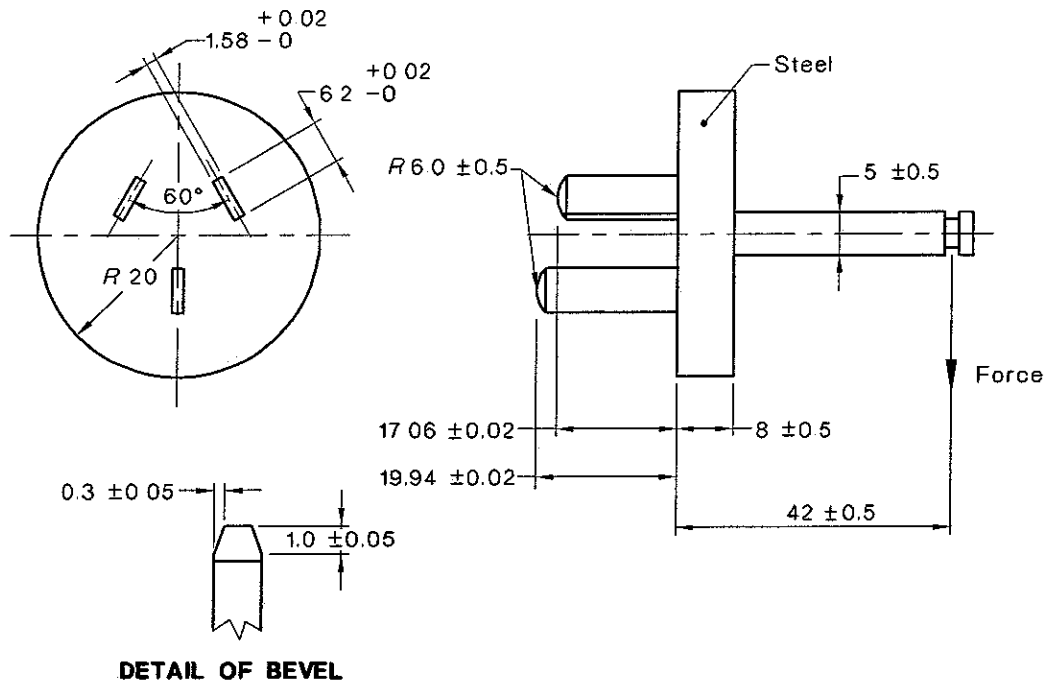

DIMENSIONS IN MILLIMETRES

NOTE: The width and thickness is identical for all pins.

FIGURE 3 6 DEVICE FOR CHECKING THE RESISTANCE TO LATERAL STRAIN (THREE-PIN GAUGE)

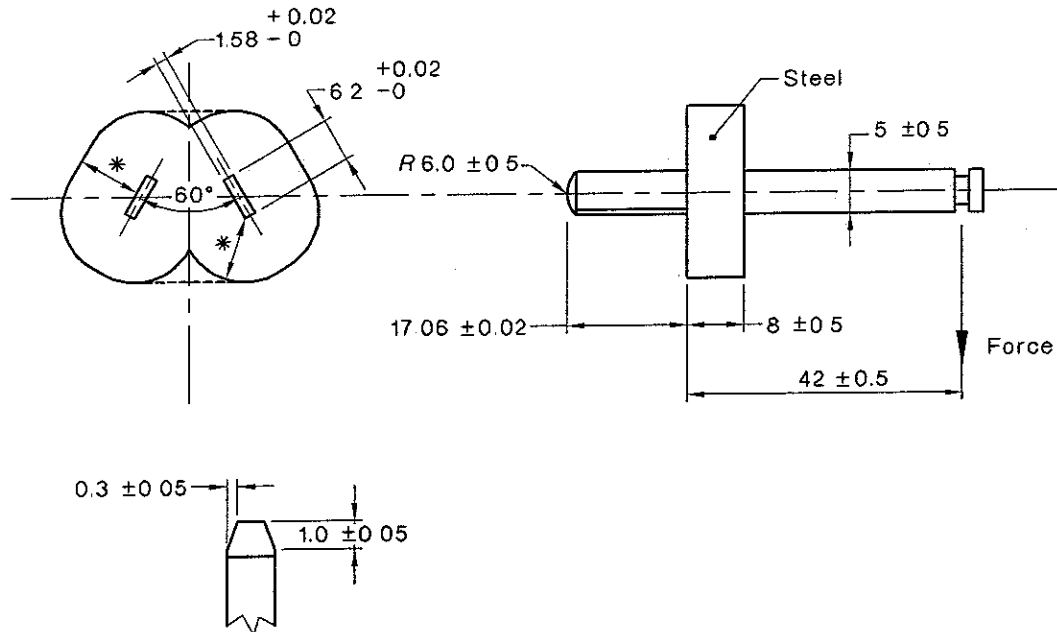

DETAIL OF BEVEL

NOTE: Dimension* is 9 mm from live parts in accordance with Clause 2.8.

DIMENSIONS IN MILLIMETRES

FIGURE 3.7 DEVICE FOR CHECKING THE RESISTANCE TO LATERAL STRAIN (TWO-PIN GAUGE)*

* This figure forms part of the Standard on publication but shall be applied 6 months after publication.

APPENDIX A
 GAUGE FOR THREE-PIN FLAT-PIN PLUGS
 (Normative)

The disposition of pins of flat-pin plugs of the types shown in Figure 2.1(a) and Figure 2.1(c) shall be checked by means of the appropriate gauge complying with Figure A1.

The plug pins shall pass easily through the gauge at all depths of insertion.

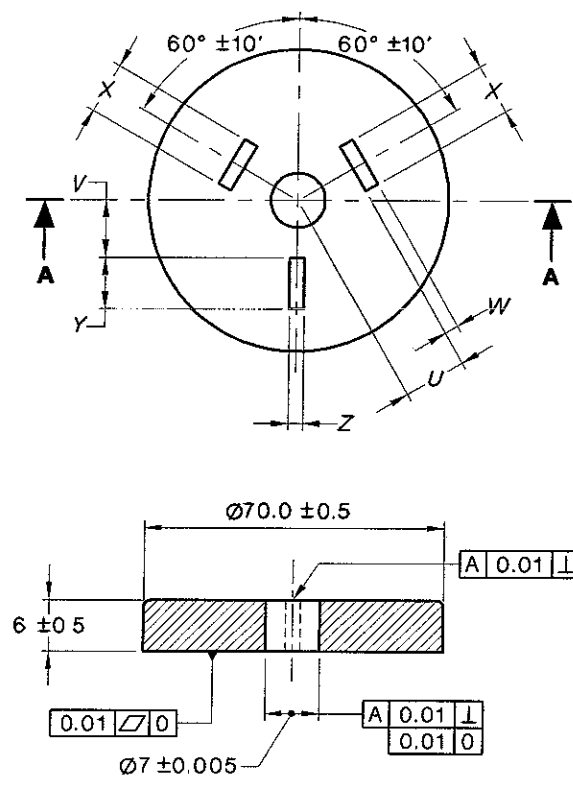

SECTION A-A

Dimension	10 A	15 A	20 A	Tolerance
U	6.83	6.83	6.05	±0.03
V	6.96	5.59	7.16	±0.03
W*	2.18	2.18	2.18	±0.03
X	7.09	7.09	9.80	±0.03
Y	6.71	9.42	9.42	±0.03
Z	1.93	1.93	1.93	±0.03

* Applies to both live pins

DIMENSIONS IN MILLIMETRES

FIGURE A1 GAUGE FOR THREE-PIN 250 V MAX FLAT-PIN PLUGS

APPENDIX B

GAUGE FOR TWO-PIN FLAT-PIN PLUGS WITH PARALLEL PINS

(Normative)

The spacing of pins of two-pin flat-pin plugs of the type shown in Figure 2.1(b) shall be checked by means of a gauge complying with Figure B1.

The plug pins shall pass easily through the gauge at all depths of insertion.

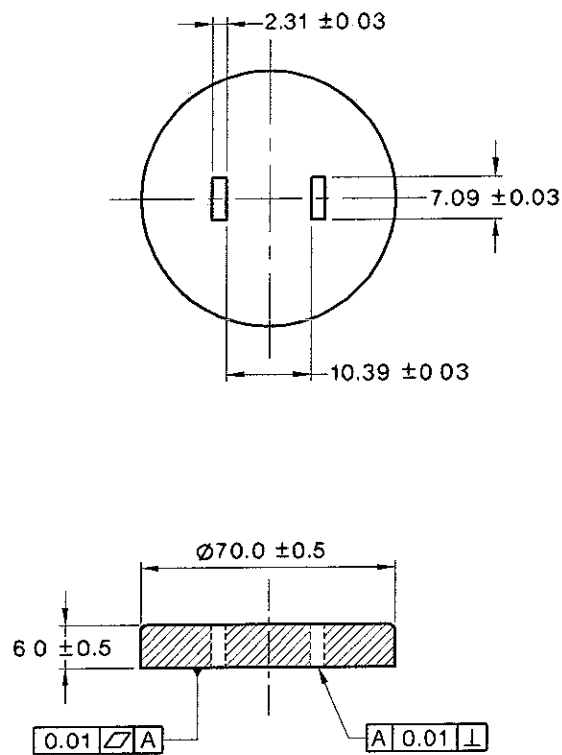

DIMENSIONS IN MILLIMETRES

FIGURE B1 GAUGE FOR TWO-PIN FLAT-PIN 125 V MAX. PLUGS
(WITH PARALLEL PINS)

APPENDIX C

THREE-PIN TEST PLUG WITH FLAT PINS FOR FULL-INSERTION TEST
AND THE FINGER TEST DURING NORMAL INSERTION TEST

(Normative)

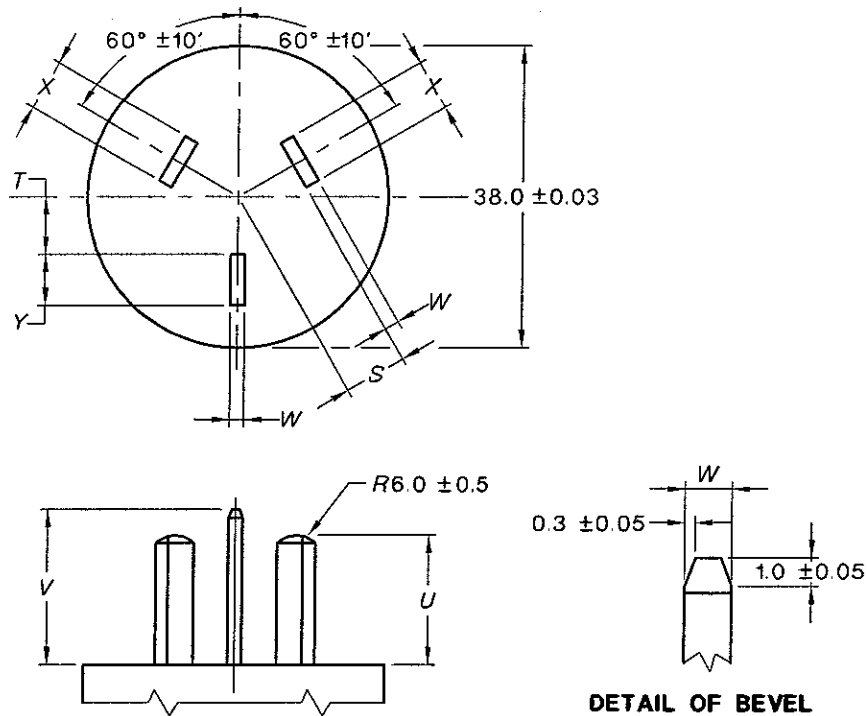

Dimension	10 A	15 A	20 A	Tolerance
S	7.05	7.05	6.26	±0.03
T	7.07	5.72	7.29	±0.03
U	17.46	17.46	17.46	±0.03
V	20.64	20.64	20.64	±0.03
W*	1.75	1.75	1.75	±0.03
X	6.50	6.50	9.19	±0.03
Y	6.50	9.19	9.19	±0.03

* Applies to all pins.

DIMENSIONS IN MILLIMETRES

FIGURE C1 THREE-PIN TEST PLUG FOR CHECKING THREE-PIN FLAT-PIN
250 V MAX. SOCKET-OUTLETS AGAINST THE STANDARD TEST FINGER
IN ACCORDANCE WITH CLAUSES 3.3.4 AND 3.8.1

APPENDIX D
THREE-PIN TEST PLUG WITH FLAT PINS FOR
ABNORMAL INSERTION TEST

(Normative)

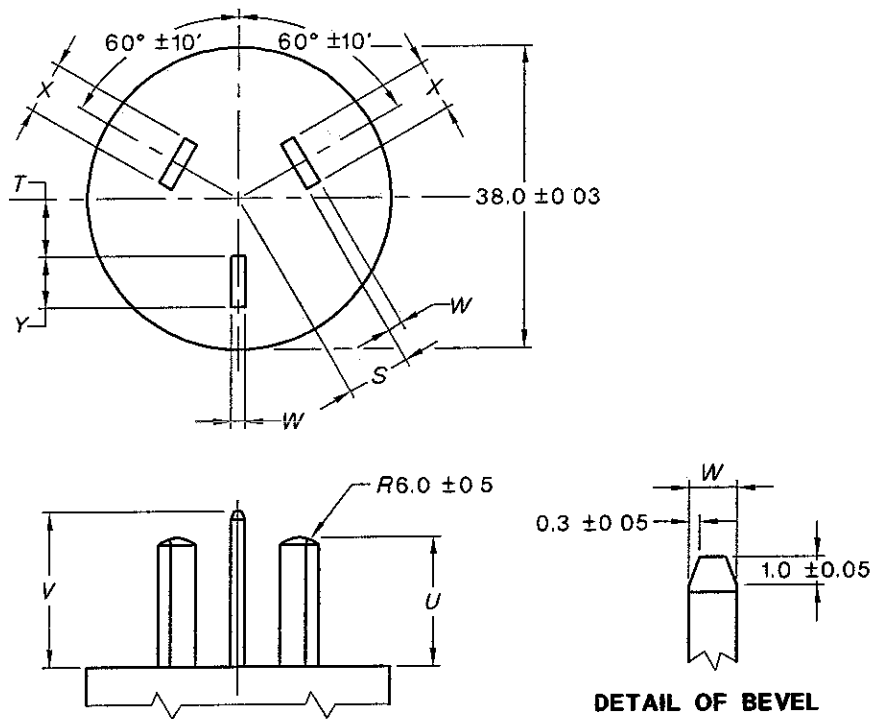

Dimension	10 A	15 A	20 A	Tolerance
S	7.11	7.11	6.32	±0.03
T	7.14	5.78	7.35	±0.03
U	17.07	17.07	17.07	±0.03
V	19.84	19.84	19.84	±0.03
W*	1.63	1.63	1.63	±0.03
X	6.35	6.35	9.07	±0.03
Y	6.35	9.07	9.07	±0.03

* Applies to all pins.

DIMENSIONS IN MILLIMETRES

FIGURE D1 THREE-PIN TEST PLUG FOR CHECKING THREE-PIN FLAT-PIN
250 V MAX. SOCKET-OUTLETS AGAINST INCORRECT INSERTION
OF PLUGS, IN ACCORDANCE WITH CLAUSE 3 8 2

APPENDIX E
PLUGS AND SOCKET-OUTLETS FOR USE
IN EXTRA-LOW VOLTAGE CIRCUITS

(Normative)

E1 GENERAL

Plugs and socket-outlets used in extra-low voltage circuits shall comply with the requirements of this Standard except for the requirements of Clauses 2.9, 2.10, 2.13.3, 3.7, 3.8.1 and 3.8.2.

NOTE: Where the ELV supply is referenced to earth, the radial pin should be the earth pin.

E2 DIMENSIONS AND RATING OF FLAT-PIN PLUGS

Flat-pin plugs for use in extra-low voltage circuits and having ratings not exceeding 15 A shall conform to the dimensions shown in Figure E1. The thickness of all pins shall be 1.63 ± 0.13 mm and all pins shall be of the same nominal width.

Plugs shall be checked for compliance with dimensions by measurement.

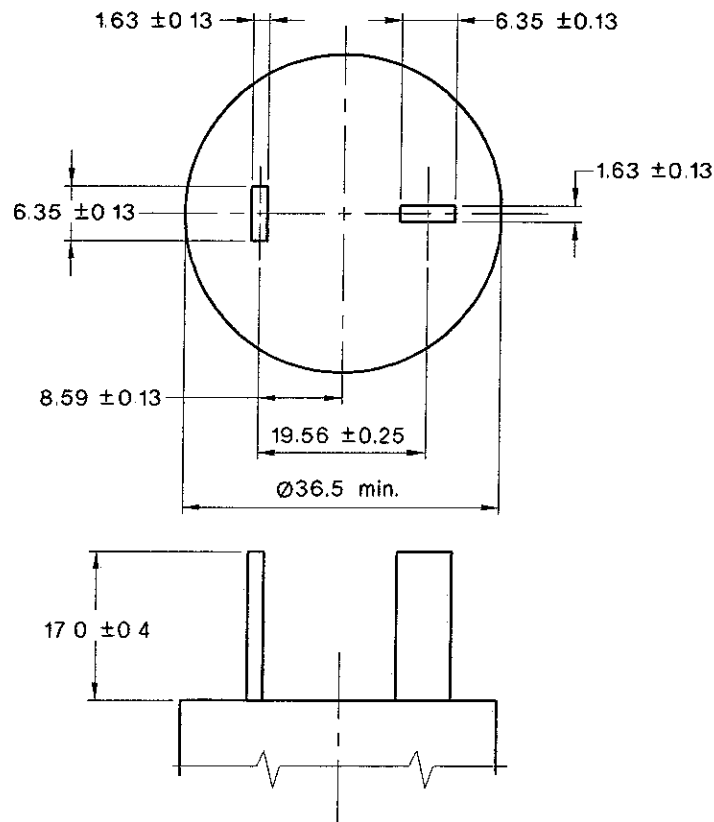

DIMENSIONS IN MILLIMETRES

NOTE: The pin ends are shown as squared-off for illustrative purposes and may be bevelled, or otherwise shaped, to facilitate entry into socket-outlets

FIGURE E1 DIMENSIONS OF EXTRA-LOW VOLTAGE FLAT-PIN PLUGS

APPENDIX F
GAUGE FOR FLAT AND ROUND PIN PLUGS

(Normative)

The disposition of pins of three-pin plugs of the type shown in Figure 2.1(f) and Figure 2.1(g) shall be checked by means of the appropriate gauge complying with Figure F1(a) and F1(b). The plug pins shall pass easily through the gauge at all depths of insertion.

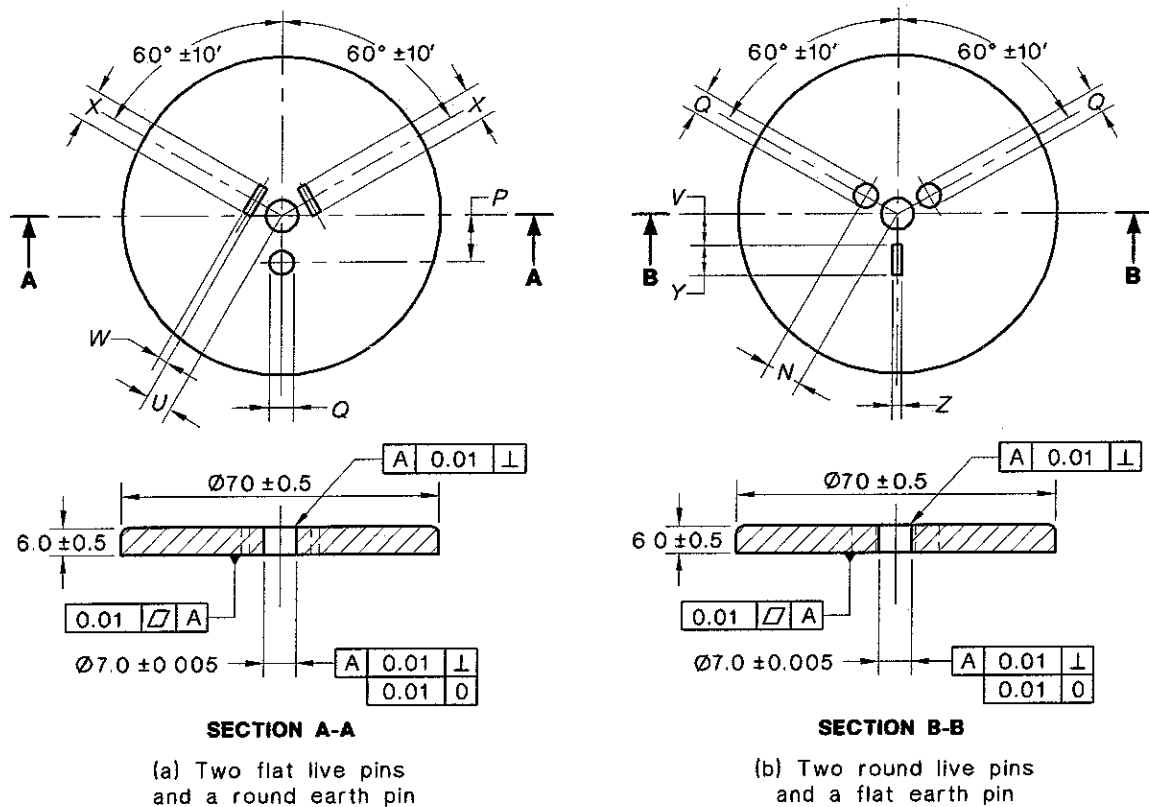

Dimension	Size	Tolerance
N	7.92	nominal
P	10.31	nominal
Q	5.25	± 0.03
U	6.83	± 0.03
V	6.96	± 0.03
W*	2.18	± 0.03
X	7.09	± 0.03
Y	6.71	± 0.03
Z	1.93	± 0.03

* Applies to both live pins.

DIMENSIONS IN MILLIMETRES

FIGURE F1 GAUGE FOR FLAT AND ROUND PIN PLUGS

APPENDIX G

THREE-PIN TEST PLUG WITH FLAT AND ROUND PINS FOR THE FULL-INSERTION TEST AND THE FINGER TEST DURING NORMAL INSERTION TEST

(Normative)

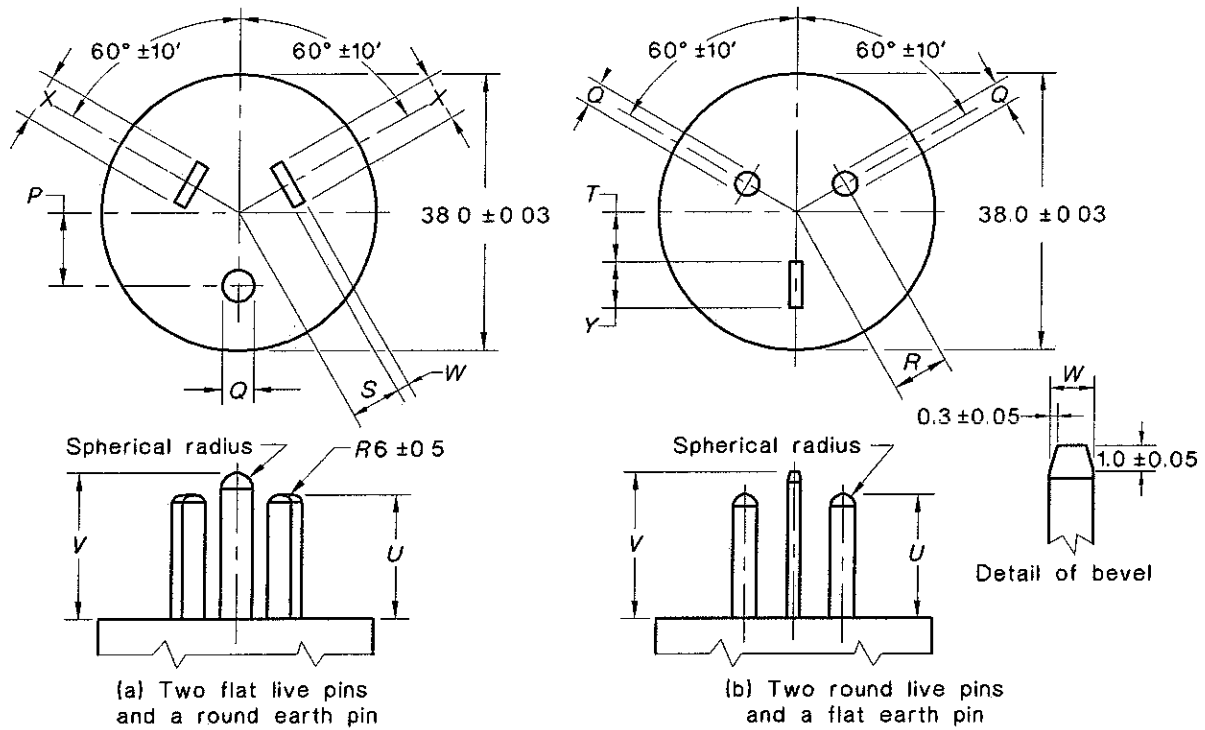

Dimension	10 A and below	Tolerance
P	10.31	nominal†
Q	4.80	±0.01
R	7.92	nominal†
S	7.05	±0.03
T	7.07	±0.03
U	17.46	±0.03
V	20.64	±0.03
W*	1.75	±0.03
X	6.50	±0.03
Y	6.50	±0.03

* Applies to both live pins

† Dimensions without tolerances are nominal and are to be checked in samples by application of the gauge specified in Appendix F, as appropriate.

DIMENSIONS IN MILLIMETRES

FIGURE G1 THREE-PIN TEST PLUG WITH FLAT AND ROUND PINS FOR TESTS TO CLAUSES 3.3.4 AND 3.8.1

APPENDIX H

DIMENSIONS FOR PLUGS AND SOCKET-OUTLETS, IP-RATED,
WITH THREADED RETAINING DEVICES

(Normative)

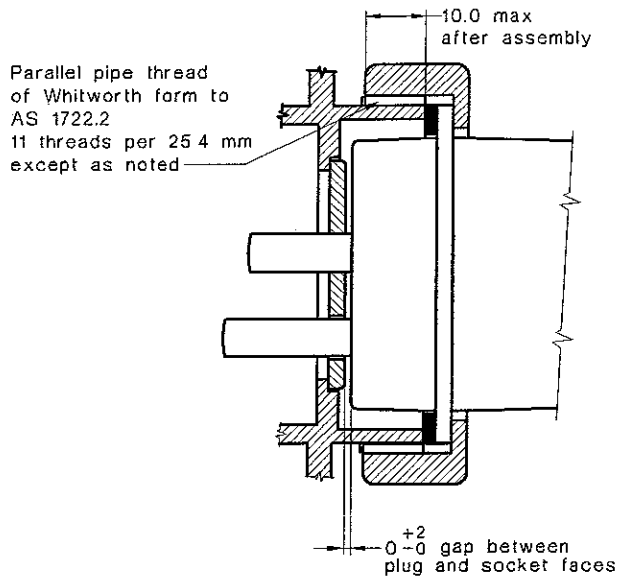

ASSEMBLY

(a)

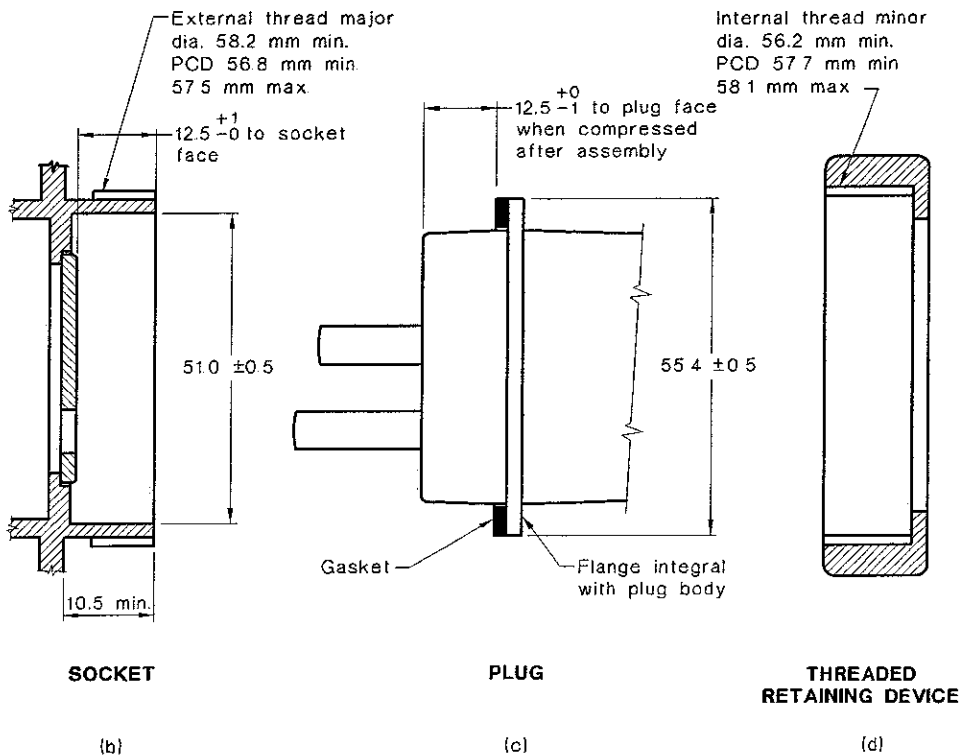

FIGURE H1 DIMENSIONS FOR IP-RATED PLUGS AND IP-RATED
SOCKETS WITH THREADED RETAINING DEVICE

APPENDIX I
(VOID)

APPENDIX J
EQUIPMENT WITH INTEGRAL PINS FOR INSERTION INTO SOCKET-
OUTLETS
(Normative)

J1 Scope

This Appendix applies to only the plug portion of equipment with integral pins and shall be read in conjunction with Section 2 contained in the body of this Standard. Where the term 'plug' is used in Section 2 it shall be taken to mean the plug portion of equipment with integral pins.

All live pins on equipment with integral pins except for those configurations shown in Figure 2.1(a2), (b) and (g) shall be of the insulated pin type from 3 April 2005.

This Appendix sets out the dimensional and constructional requirements, including the attachment of the integral pins of plug portions of equipment with integral pins. It does not however include requirements for electrical connections to the integral pins or other requirements, which are covered by the relevant product standard for the equipment with integral pins.

J2 Requirements for the plug portion

J2.1 Definition

J2.1.1 *Plug portion*

That portion of equipment with integral pins shown in Figure 2.1, including the plug pins, terminals of the plug pins and external dimensions of the 'maximum projection'.

J2.2 Requirements

The following provisions apply to the dimensional and constructional requirements of the plug portion of equipment with integral pins. It is not intended that this Appendix apply to equipment with integral pins which are covered by particular product standards however, where such devices have plug portions, these standards may refer to this Appendix, to supplement the requirements contained in those particular product standards.

J2.2.1 *Plug pins of plug portions*

The requirements of Clause 2.2 are applicable for plug pins.

J2.2.2 *Ratings and dimensions for low voltage plug portions*

The requirements of Clauses 2.8.1 and 2.8.4 are applicable for ratings and dimensions.

J2.2.3 *Internal connections for plug portions*

The requirements of Clause 2.9 are applicable for internal connections unless requirements are contained in the relevant product standard.

J2.2.4 *Arrangement of earthing connections for plug portions*

The requirements of Clause 2.10 are applicable for the arrangement of earthing connections.

J2.2.5 *Configuration of plug portions*

The requirements of Clause 2.12.6 are applicable to the configuration of the plug portion.

J2.2.6 Tests

J2.2.6.1 General

Plug portions of equipment with integral pins shall be subjected to the following tests and unless stated otherwise, shall comply with the requirements specified in Section 2 for each test. The number of test samples shall be in accordance with Table 2.2.

J2.2.6.2 High voltage test

The requirements of Clause 2.13.3 are applicable unless requirements are contained in the relevant product standard.

J2.2.6.3 Mechanical strength of pin tests

J2.2.6.3.1 Tumbling barrel test

The tumbling barrel test is applied to determine the mechanical strength of the plug pins.

Three samples which have not been subjected to any previous test are tested to the requirements of Clause 2.13.7.1 however, the test is modified for plug portions of equipment with integral pins as follows:

A sample of equipment with integral pins is dropped—

- (a) 500 times if the mass of the specimen does not exceed 250 g. The pins being straightened after each 100 drops and at the completion of the test to pass through the appropriate gauge of Figure A1, B1 or F1; and
- (b) 250 times if the mass of the specimen exceeds 250 g. The pins being straightened after each 25 drops and at the completion of the test to pass through the appropriate gauge of Figure A1, B1 or F1.

Following each test the samples shall comply with Item (e) of Clause 2.13.7.1.

J2.2.6.3.2 Pin bending test

The pins of the plug portion of three samples not subjected to any previous tests shall be tested for compliance with the pin bending test of Clause 2.13.7.2.

J2.2.6.4 Temperature rise test

The relevant requirements of Clause 2.13.8 are applicable for the temperature rise test, except that the test current shall be that specified in the relevant product Standard.

The temperature rise of the pins shall not exceed 45 K irrespective of the temperature rise of parts specified in end product standards.

J2.2.6.5 Securement of pins of the plug portion

The requirements of Clause 2.13.9 are applicable for the securement of pins.

J2.2.6.6 Tests on the insulation material of insulated pin plug portions

The requirements of Clause 2.13.13 are applicable for insulating material of insulated plug pins.

NOTE: Except for those plug pins described in Figure 2.1(a2), (b) and (g) all live pins on equipment with integral pins shall be of the insulated type from 3 April 2005

J2.2.6.7 *Equipment with integral pins intended to be supported by the contacts of a socket-outlet*

Equipment with integral pins intended to be supported by the contacts of socket-outlets shall not impose undue strain on those socket-outlets.

Unless requirements are contained in the relevant product standard, compliance is checked by inserting the equipment with integral pins, as in normal use, into a flush-mounting combination switch socket-outlet complying with this Standard, the socket-outlet being pivoted about a horizontal axis through the centre-lines of the contact apertures at a distance of 8 mm behind the engagement face of the socket-outlet. (See Figure J1). The additional torque, which has to be applied to the socket-outlet to maintain the engagement face in the vertical plane, shall not exceed 0.25 N.m.

Where the equipment with integral pins is fitted with a flexible cord, the test is conducted with the centre-line of the axis of pivot of the socket-outlet located at a point 500 mm above a horizontal surface. The flexible cord is allowed to hang freely from the equipment with that flexible cord in excess of 500 mm resting on the horizontal surface during the test.

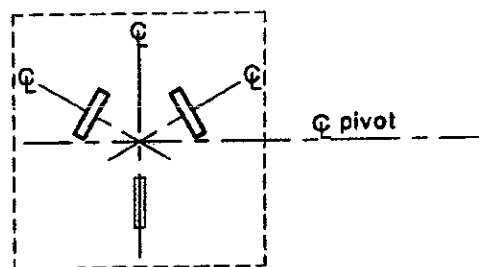

FIGURE J1 ARRANGEMENT FOR DETERMINATION OF PIVOT

NOTES

Standards Australia

Standards Australia is an independent company, limited by guarantee, which prepares and publishes most of the voluntary technical and commercial standards used in Australia. These standards are developed through an open process of consultation and consensus, in which all interested parties are invited to participate. Through a Memorandum of Understanding with the Commonwealth government, Standards Australia is recognized as Australia's peak national standards body.

Standards New Zealand

The first national Standards organization was created in New Zealand in 1932. The Standards Council of New Zealand is the national authority responsible for the production of Standards. Standards New Zealand is the trading arm of the Standards Council established under the Standards Act 1988.

Australian/New Zealand Standards

Under a Memorandum of Understanding between Standards Australia and Standards New Zealand, Australian/New Zealand Standards are prepared by committees of experts from industry, governments, consumers and other sectors. The requirements or recommendations contained in published Standards are a consensus of the views of representative interests and also take account of comments received from other sources. They reflect the latest scientific and industry experience. Australian/New Zealand Standards are kept under continuous review after publication and are updated regularly to take account of changing technology.

International Involvement

Standards Australia and Standards New Zealand are responsible for ensuring that the Australian and New Zealand viewpoints are considered in the formulation of international Standards and that the latest international experience is incorporated in national and Joint Standards. This role is vital in assisting local industry to compete in international markets. Both organizations are the national members of ISO (the International Organization for Standardization) and IEC (the International Electrotechnical Commission).

Visit our web sites

www.standards.org.au

www.standards.co.nz

www.standards.com.au



STANDARDS AUSTRALIA

GPO Box 5420 Sydney NSW 2001

Administration

Phone (02) 8206 6000

Fax (02) 8206 6001

Email mail@standards.com.au

Customer Service

Phone 1300 65 46 46

Fax 1300 65 49 49

Email sales@standards.com.au

Internet www.standards.org.au



STANDARDS NEW ZEALAND *Tekeke Tekeke*

Level 10 Radio New Zealand House

155 The Terrace Wellington 6001

(Private Bag 2439 Wellington 6020)

Phone (04) 498 5990

Fax (04) 498 5994

Customer Services (04) 498 5991

Information Service (04) 498 5992

Email snz@standards.co.nz

Internet www.standards.co.nz