

# APPLICATION NOTE

**ABSTRACT**

This application note describes a low cost design that adds a DALI interface to existing TL ballast applications based on analog driver ICs.

**AN10225**

**P87LPC760 based DALI slave**

Author: Paul Seerden

2003 May 15

# P87LPC760 based DALI slave

AN10225

## INTRODUCTION

This report describes the design of a DALI (Digitally Addressable Lighting Interface) slave unit, based on the P87LPC760 microcontroller from Philips Semiconductors. Furthermore, it illustrates how the slave unit design is used to add DALI functionality to an existing HF-TL dimmable ballast design.

The complete (DALI ballast) application (see figure 1) contains two main parts:

1. The ballast control section
2. The DALI slave control section

The communication between the ballast and the external world is done with just two signals (Tx and Rx), allowing the ballast to communicate bi-directional with the DALI system network. An optical isolated digital interface assures high voltage isolation between the DALI inputs and the lamp output stage.

## DALI

The international standard (IEC929) DALI-bus communication protocol is intended for use in intelligent lighting systems. In a typical application, a DALI-bus consists of one (master) controller, and multiple slaves (normally TL-ballasts). It can control up to 64 different slaves (ballasts) within the same control system. It's possible to transmit instructions to single ballasts or to a group of ballasts.

The DALI bus consists of two wires, providing a differential signal. Data is transmitted in frames. There are two different frame types: a "forward" frame (sent by the master to the slaves), and a "backward" frame (sent by a slave to the master, possibly containing status info).

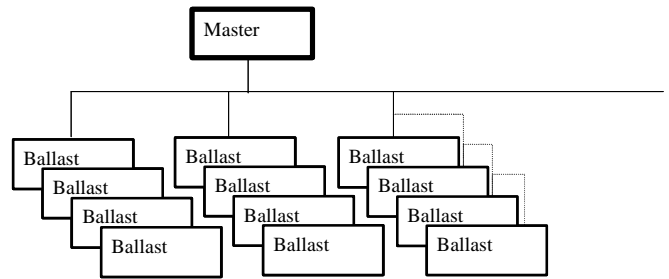

Fig. 2 DALI network structure

Examples of frames (commands / instructions) send by a master to a slave could be: set a new brightness (dim) value or lamp on / off.

DALI uses bi-phase (Manchester) encoding, which means that the data is transmitted using the edges of the signal. A rising edge indicates a '1', a falling edge indicates a '0'.

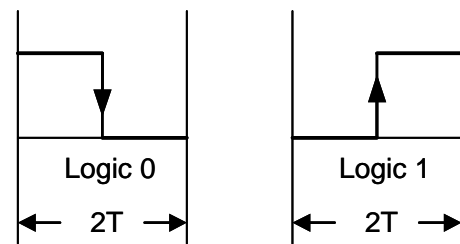

Fig. 3 Bi-phase code bits

Every bit takes two periods T. A message is started by a start bit, and ends with two high-level stop bits (No change of phase). Data is being transmitted with the MSB first. Between frames, the bus is in idle. Speed of the DALI interface is 2400 bits/sec.

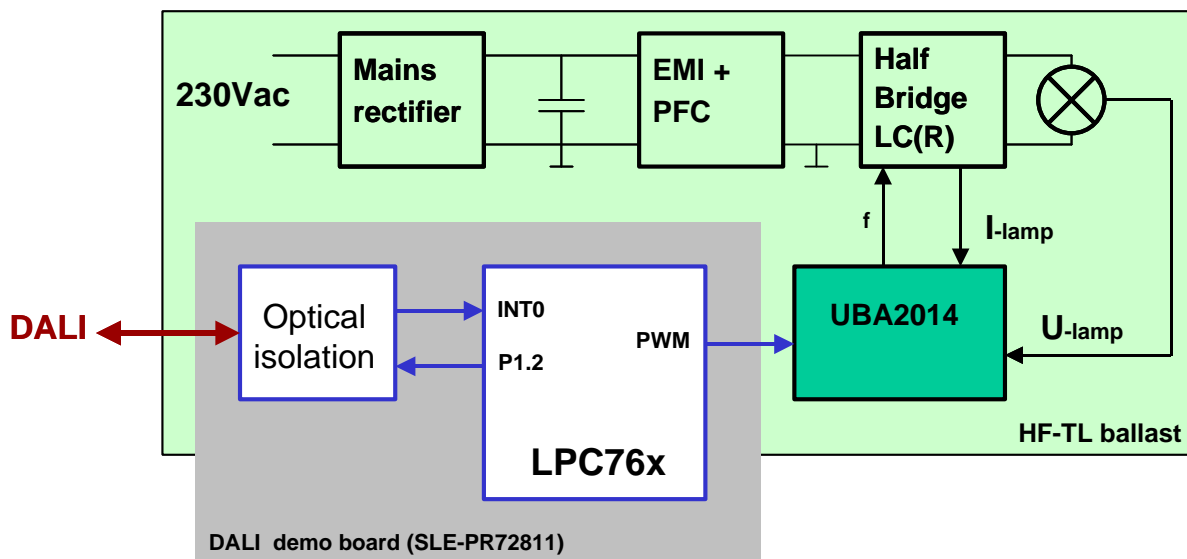

Fig. 1 DALI dimmable ballast

# P87LPC760 based DALI slave

AN10225

## BALLAST CONTROL

The ballast control section is build around the **UBA2014** driver IC from Philips Semiconductors.

The UBA2014 integrated half bridge driver IC has been designed for driving electronically ballasted fluorescent lamps. The UBA2014 is used for preheating and igniting the lamp, controlling the lamp power and for detection of fault conditions.

The IC provides the drive function for two discrete power MOSFETs. Besides that, the UBA2014 includes a level-shift circuit, the oscillator, a lamp voltage monitor, a current control function and an analog dimming interface. The datasheet and other additional information about this driver IC can be found on the Philips Internet site.

To test the complete (DALI ballast) application we used a UBA2014 hardware reference design. This design includes a demonstration board (see figure 4) to control a 36W TLD lamp. A complete description of this board (schematics, parts list, etc) is given in application note: AN10181, also available on the Internet. The complete circuit of this board is shown in Appendix A.



Fig. 4 36W TLD application with UBA2014

The UBA2014 controls the ballast according to an analog input voltage received from the microcontroller (PWM output).

## DALI SLAVE CONTROLLER

The DALI control section is build around the **P87LPC760** microcontroller from Philips Semiconductors. The microcontroller acts as an interface between the UBA2014 ballast controller and the DALI network.

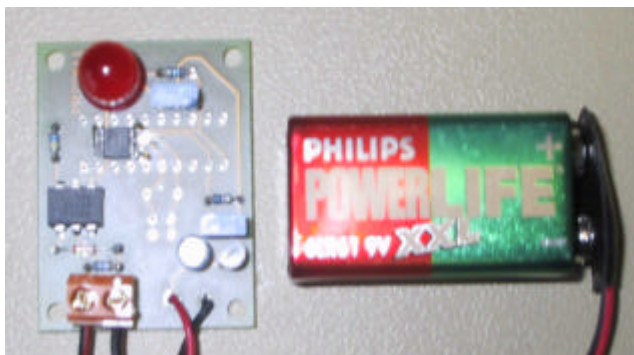

Fig. 5 P87LPC760 based DALI slave unit

The interface to the ballast controller is implemented with just one signal (see figure 6). Port P1.0 of the microcontroller is used to generate a software PWM output signal. Via an external RC network this signal is transformed to an analog voltage, which is offered to the CS+ (pin 15) input of the UBA2014 (remove R2, R3, R4 and C3). This way the microcontroller has the possibility to control the output power to the lamp (dimming), by just changing the duty cycle of the PWM output.

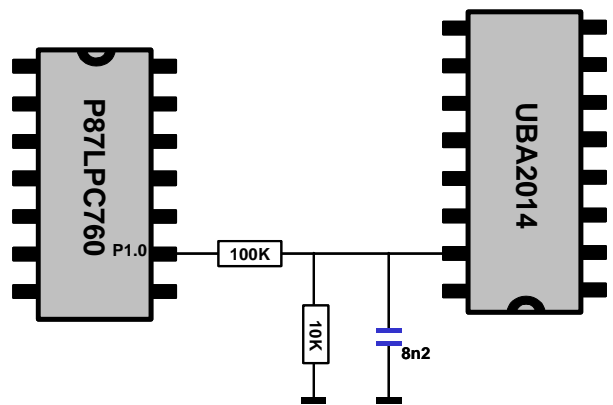

Fig. 6 P87LPC760 – UBA2014 interface

The hardware interface to the DALI bus (see figure 7) is used for data transfers with the master. The P87LPC760 interprets the data and sets the appropriate output voltage to the ballast controller.

The DALI bus is optically isolated from the microcontroller. For transmission of data an opto-relay, connected to port pin P1.7 of the microcontroller is used. By almost shortcircuiting the DALI bus wires it lowers the voltage since the current is limited (20 mA current loop).

The reception of DALI messages is done by an optocoupler. The output is connected to an interrupt input of the microcontroller for proper Manchester encoding.

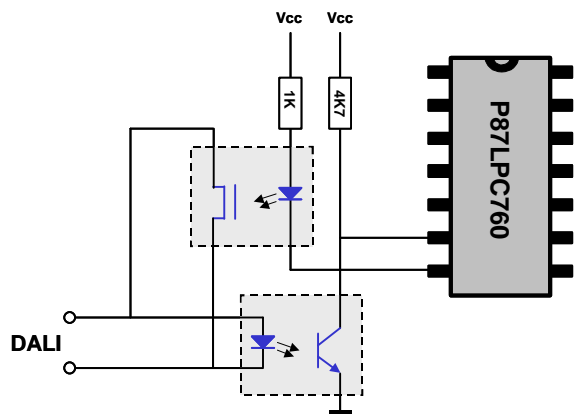

Fig. 7 P87LPC760 - DALI interface

# P87LPC760 based DALI slave

AN10225

## SOFTWARE

The software for the dimmable DALI ballast contains three main parts:

1. DALI driver software
2. DALI message handler
3. PWM output to ballast controller

For the first part, preceding this DALI ballast application, a separate driver for Manchester encoding with Philips C51 microcontrollers was developed and described in an application note (see references).

For sending, this driver uses Timer 0 interrupt every period 'T' to generate the DALI message. Sending a single bit via a bi-phase encoding requires two interrupts, in order to produce a good transition. A '1' is sent by pulling down the line for one period, followed by releasing it for one period. Sending a '0' is exactly the opposite. A counter is used to keep track of which bit is being transmitted. For reception of a DALI message the driver uses the EX0 interrupt line and Timer 0 to measure pulse widths. For a complete and detailed description of this part of the software please refer to AN10226, "C51 DALI driver software", which is available on the web.

Decoding of the DALI messages is straight-forward and quite simple to understand from the source code. For the generation of a PWM output signal (third part of the software) to the UBA2014 ballast driver, timer 1 of the P87LPC760 is used.

## SOURCE CODE

Code file of this application note is available on request. Please enter your request at:

[http://www.semiconductors.philips.com/markets/mms/products/microcontrollers/support/training\\_education/technical\\_support/index.html](http://www.semiconductors.philips.com/markets/mms/products/microcontrollers/support/training_education/technical_support/index.html)

## REFERENCES

For further details please refer to the following publications:

- Datasheets / app. notes:  
[www.semiconductors.philips.com](http://www.semiconductors.philips.com)
- "Remote control system RC-5"  
doc. Nr: 9398 706 23011
- AN10181: "36W TLD application with the UBA2014"
- AN10226: "C51 DALI driver software"
- AN467: "Philips 51LPC Microcontrollers & Triacs easily connected"
- Example Programs:  
<http://www.keil.com/download/c51.asp>

# P87LPC760 based DALI slave

AN10225

## APPENDIX A: UBA2014 DEMO BOARD

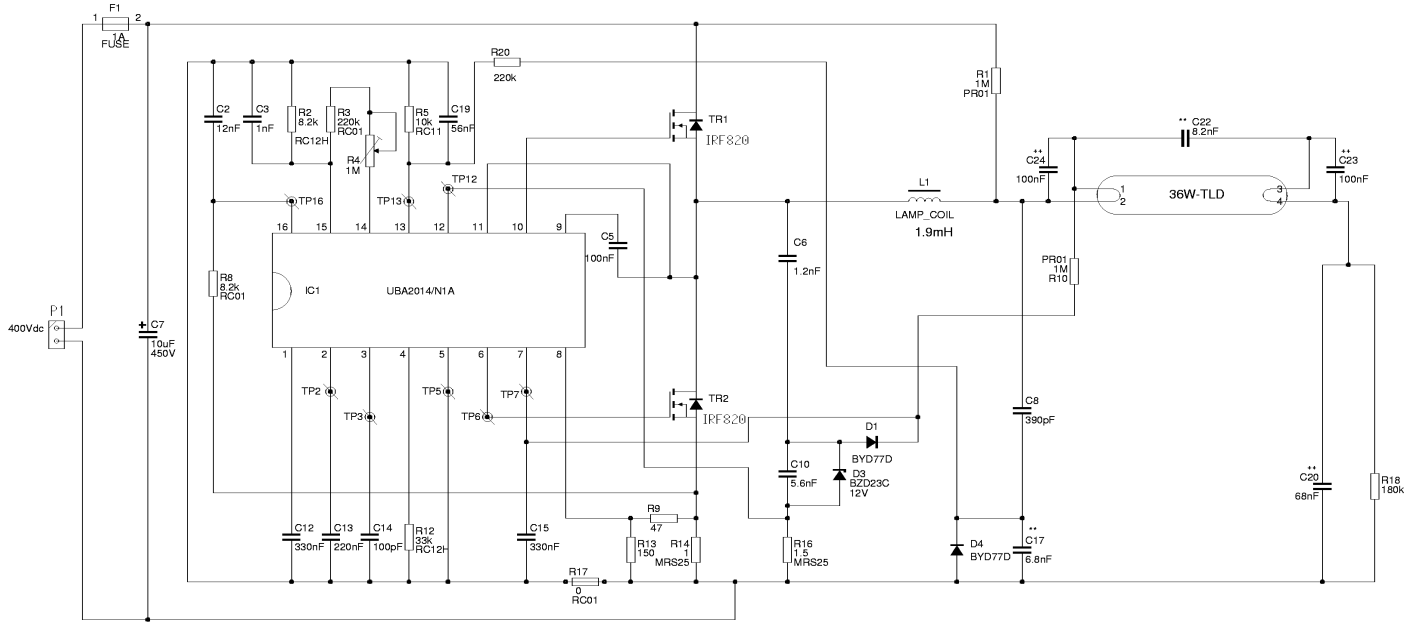

## APPENDIX B: MICROCONTROLLER AND POWER SUPPLY

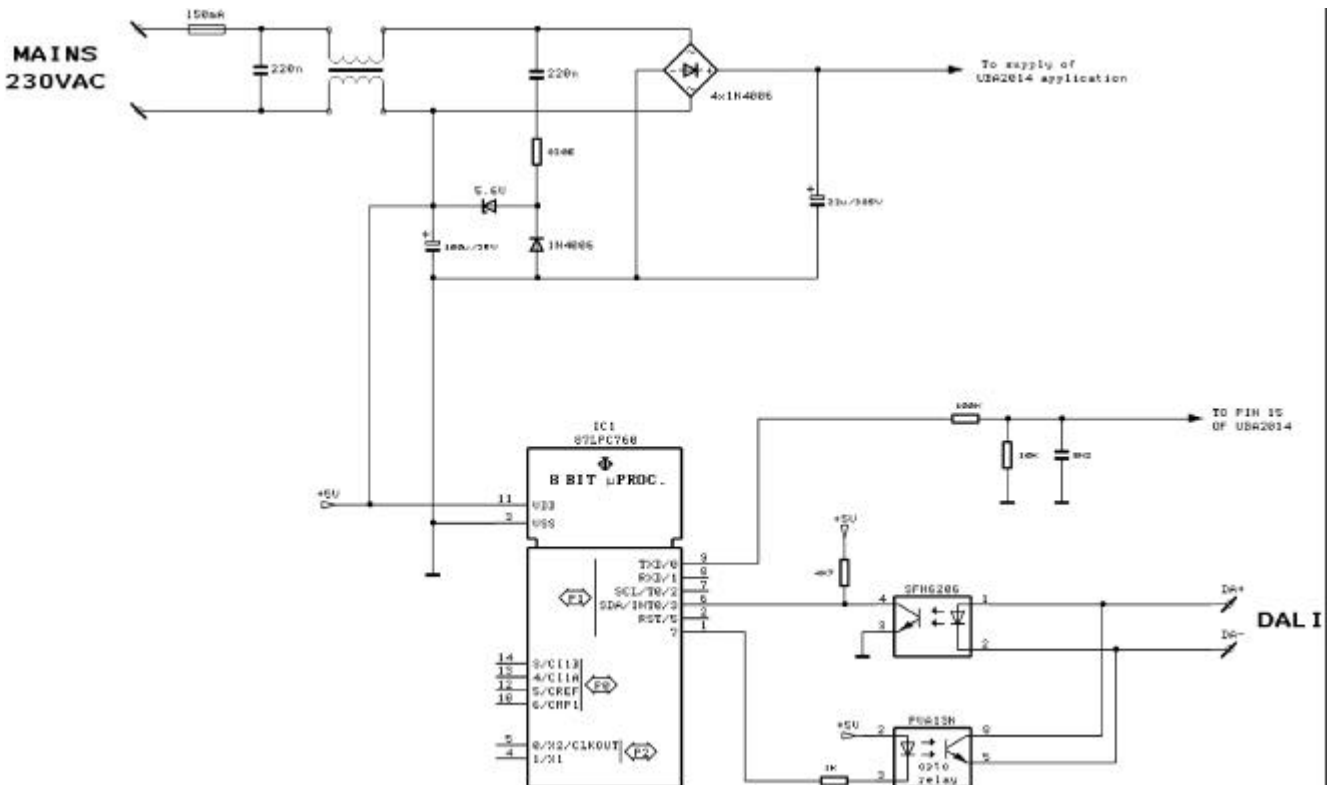

---

**P87LPC760 based DALI slave**

---

AN10225

---

**Definitions**

**Short-form specification** – The data in a short-form specification is extracted from a full data sheet with the same type number and title. For detailed information, see the relevant datasheet or data handbook.

**Limiting values definition** – Limiting values given are in accordance with the Absolute Maximum Rating System (IEC134). Stress above one or more of the limiting values may cause permanent damage to the device. These are stress ratings only and operation of the device at these or at any other conditions above those given in the Characteristics sections of the specification is not implied. Exposure to limiting values for extended periods may affect device reliability.

**Application information** – Applications that are described herein for any of these products are for illustrative purposes only. Philips Semiconductors make no representation or warranty that such applications will be suitable for the specified use without further testing or modification.

**Disclaimers**

**Life support** – These products are not designed for use in life support appliances, devices or systems where malfunction of these products can reasonably be expected to result in personal injury. Philips Semiconductors customers using or selling these products for use in such applications do so at their own risk and agree to fully indemnify Philips Semiconductors for any damages resulting from such application.

**Right to make changes** – Philips Semiconductors reserves the right to make changes, without notice, in the products, including circuits, standard cells, and/or software, described or contained herein in order to improve design and/or performance. Philips Semiconductors assumes no responsibility or liability for the use of any of these products, conveys no license or title under any patent, copyright, or mask work right to these products, and makes no representations or warranties that these products are free from patent, copyright, or mask work right infringement, unless otherwise specified.

---

**Contact information**

For additional information please visit  
<http://www.semiconductors.philips.com>. Fax: +31 40 27 24825

© Koninklijke Philips Electronics Electronics N.V. 2002  
All rights reserved. Printed in U.S.A

For sales offices addresses send e-mail to:  
[sales.addresses@www.semiconductors.philips.com](mailto:sales.addresses@www.semiconductors.philips.com)

*Let's make things better.*

**Philips  
Semiconductors**



**PHILIPS**