

un-Isolation maximum up to 12W

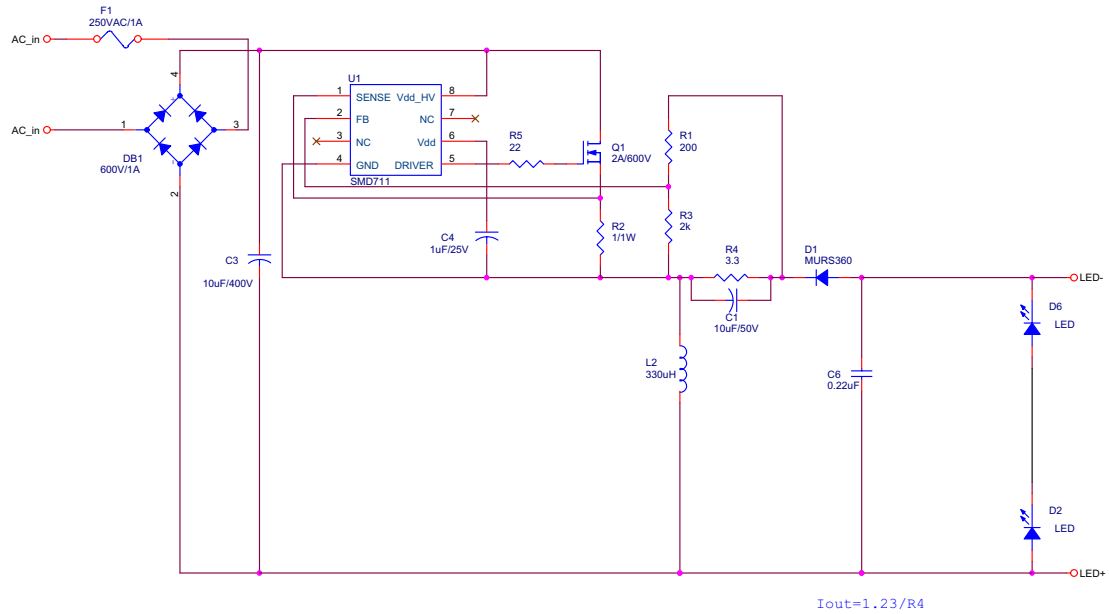

Fig1. If the rail of LEDs is opened, the V_{out} may be up to 400Vdc, Now constant is 350mA (max up to 8 LEDs in series), if want up to 700mA or 1.05A should be change Q1 and D1 to 3A or 4A and R2 should be change to 0.62R/1W and R4 should be change to 1.65R or 1.1R/1.5W.

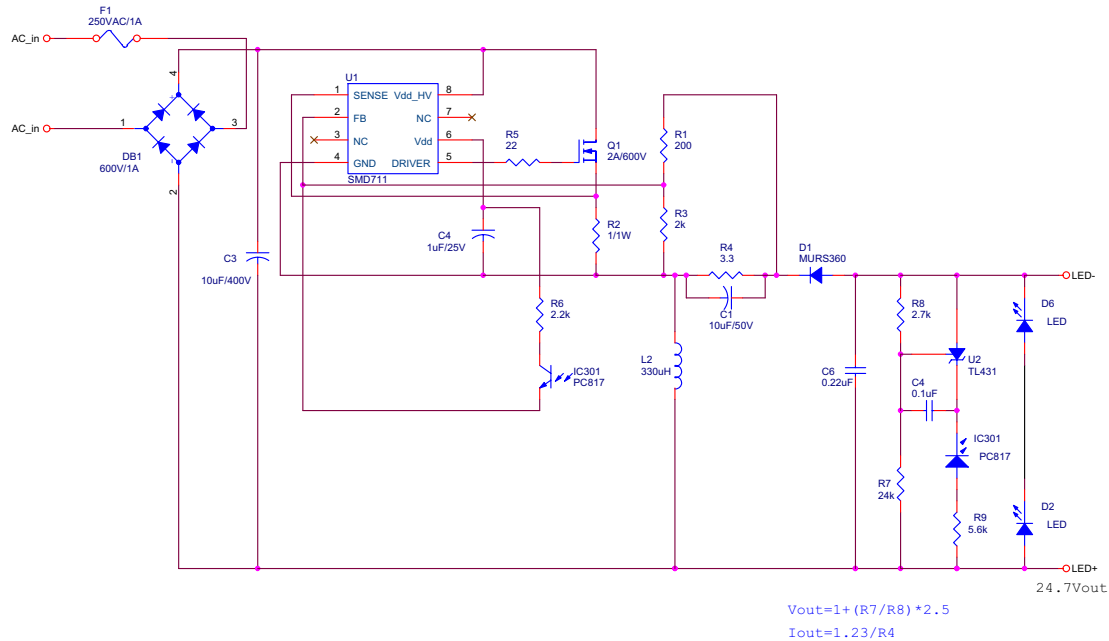

Fig2. If the rail of LEDs is opened, the V_{out} is 24.7V. Maximum V_{out} is up to 40V and V_{out} must be larger than total LEDs VF voltage.

Efficiency:	120Vdc	81.9%
	160Vdc	81.4%
	240Vdc	80.7%
	320Vdc	78.9%
	360Vdc	77.7%