

DESCRIPTION

The AMC7140 is a high voltage, low drop-out current regulator for maximum output current up to 700mA. The output current was decided by external resistor. The output sink current could be disabled via OE pin

Build-in thermal protection to prevent the chip over heat damage.

FEATURES

- 0.5V Output Drop-out Voltage at 700mA.
- 700mA Maximum Output Current.
- Output Current Controlled by External Resistor.
- 3us Fast Response Output Stage Enable Control.
- Output Driving Voltage Up To 75V.
- Supply Voltage Range 5V~50V
- TO-252-5L package

TYPICAL APPLICATION CIRCUIT

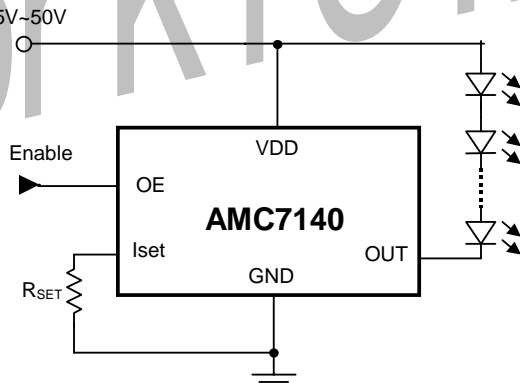

APPLICATIONS

- High Power LED Driver
- RGB Full Color Power LED driver
- LCD Monitor/TV LED backlight Driver
- LED Table Lamp

PACKAGE PIN OUT

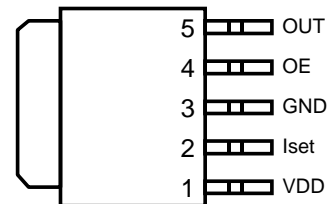

TO-252-5L

(Top View)

ORDER INFORMATION

DL	TO-252
	5 pin
AMC7140DLFT (Lead Free)	
<p>Note: All surface-mount packages are available in Tape & Reel. Append the letter "T" to part number (i.e. AMC7140DLFT). The letter "F" is marked for Lead Free process.</p>	

ABSOLUTE MAXIMUM RATINGS (Note)

Input Voltage, V_{DD}	50V
Output Voltage, V_{OUT}	75V
Maximum Operating Junction Temperature, T_J	150°C
Storage Temperature Range	-65°C to 150°C
Lead Temperature (soldering, 10 seconds)	260°C

Note: Exceeding these ratings could cause damage to the device. All voltages are with respect to Ground. Currents are positive into, negative out of the specified terminal.

PIN DESCRIPTION

Pin Name	Pin Function
OUT	Output pin. Sink current is decided by the current on R_{SET} connected to I_{SET} . $I_{OUT} = 500 \times I_{SET}$.
OE	Output stage enable control pin. High enable the OUT pin.
I_{SET}	Output current set input. Connect a resistor from I_{SET} to GND to set the LED bias current. $I_{SET} = 1.2V/R_{SET}$.
VDD	Power supply.
GND	Ground

THERMAL DATA

Thermal Resistance from Junction to Ambient, θ_{JA}	80 °C /W
Junction Temperature Calculation: $T_J = T_A + (P_D \times \theta_{JA})$. The θ_{JA} numbers are guidelines for the thermal performance of the device/pc-board system. Connect the ground pin to ground using a large pad or ground plane for better heat dissipation. All of the above assume no ambient airflow.	

Maximum Power Calculation:

$$P_{D(MAX)} = \frac{T_{J(MAX)} - T_{A(MAX)}}{\theta_{JA}}$$

T_J (°C): Maximum recommended junction temperature

T_A (°C): Ambient temperature of the application

θ_{JA} (°C /W): Junction-to-Ambient temperature thermal resistance of the package, and other heat dissipating materials.

The maximum power dissipation for a single-output regulator is:

$$P_{D(MAX)} = [(V_{IN(MAX)} - V_{OUT(NOM)}) \times I_{OUT(NOM)} + V_{IN(MAX)} \times I_Q]$$

Where: $V_{OUT(NOM)}$ = the nominal output voltage
 $I_{OUT(NOM)}$ = the nominal output current, and
 I_Q = the quiescent current the regulator consumes at $I_{OUT(MAX)}$
 $V_{IN(MAX)}$ = the maximum input voltage

Then $\theta_{JA} = (+150^\circ\text{C} - T_A)/P_D$

Preliminary

RECOMMENDED OPERATING CONDITIONS

Parameter	Symbol	Min	Typ	Max	Unit
Supply Voltage	V_{DD}	5		50	V
Output Sink Current	I_{OUT}			700	mA
Operating free-air temperature range	T_a	-40		+85	°C

DC ELECTRICAL CHARACTERISTICS

$V_{DD}=24V$, $T_a=25^{\circ}C$, No Load, (Unless otherwise noted)

Parameter	Condition	Min	Typ	Max	Unit
Output Current	$V_{OUT}=0.5V$, $R_{SET}=4K\Omega$		150		mA
	$V_{OUT}=0.5V$, $R_{SET}=1.2K\Omega$		500		
Output Current Deviation	$V_{OUT}=0.5V$, $R_{SET}=4K\Omega$			± 5	%
	$V_{OUT}=0.5V$, $R_{SET}=1.2K\Omega$			± 5	
SET Current Range		200		1400	μA
Maximum Output Current	$I_{SET}=1400\mu A$		700		mA
Output Drop-out Voltage*	$I_{SET}=1000\mu A$, Note 1		0.35		V
Thermal Shut-down Junction Temperature	Hysteresis $20^{\circ}C$		160		°C
“Low” Input Voltage		0		0.8	V
“High” Input Voltage		2		12	V
“Low” Input Current		-20		+20	μA
“High” Input Current		-5.0		+5.0	μA
Output Enable Delay Time	OE from Low to High, $V_{OUT}=0.5V$, $I_{OUT}=350mA$, 50%		3		μS
Output Disable Delay Time	OE from High to Low, $V_{OUT}=0.5V$, $I_{OUT}=350mA$, 50%		3		μS
Supply Current Consumption				5	mA

Note1: Output dropout voltage: $90\% \times I_{OUT} @ V_{OUT}=500mV$

APPLICATION INFORMATION

AMC7140 is a high voltage, low dropout current regulator for maximum output current up to 700mA with OE pin. The current could be linearly adjusted through variable resistor connected to I_{SET} pin, or by PWM control via OE pin. Although the absolute maximum rating of OUT pin 60V, the dropout voltage between OUT pin and GND pin should not be too large when current is sinking because of the heat dissipation capability of the package.

Here are some of the typical application examples:

DC Voltage Input:

Any DC voltage level between 5V to 50V could be adopted as power source V_{DD} for typical application of AMC7140 as long as V_{DD} is larger than the total forward voltage drop of the LED string (at expecting current) by 0.35V. If 50V ~ 60V voltage level is adopted as power source to positive end of the LED string, one Zener shunt regulator could be used to provide appropriate voltage to V_{DD} pin.

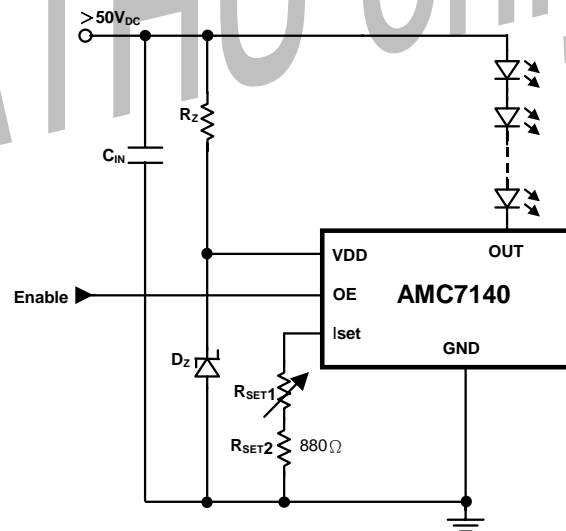
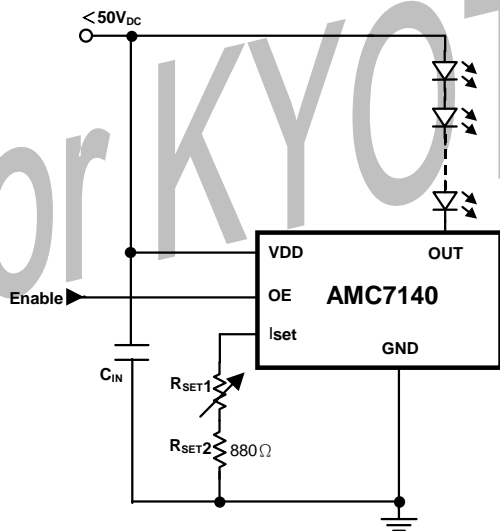

Preliminary

LED Backlight Solution:

AMC7140 could coordinate with any type of DC-to-DC converter through feedback path to realized LED backlight module. The number of LEDs in the string is variable even with certain fixed power source since the output voltage of the DC-to-DC converter could be modulated according to feedback signal.

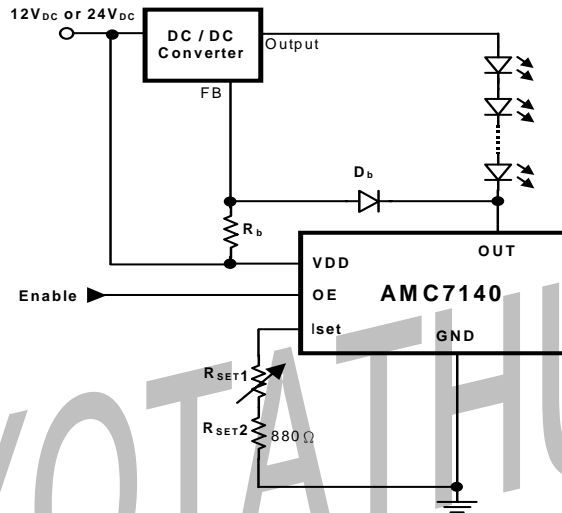
AC Voltage Input:

AMC7140 could work with any kind of well-known or well-developed switch-mode power supply system. Simply cut off the internal feedback path of the power supply system and then feed the signal from AMC7140 back to the power supply system instead.

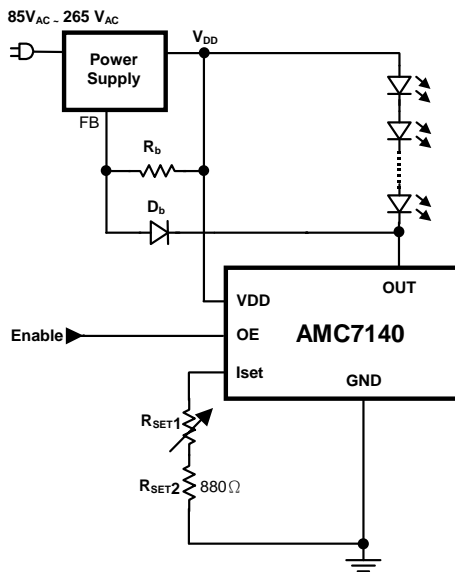

Preliminary

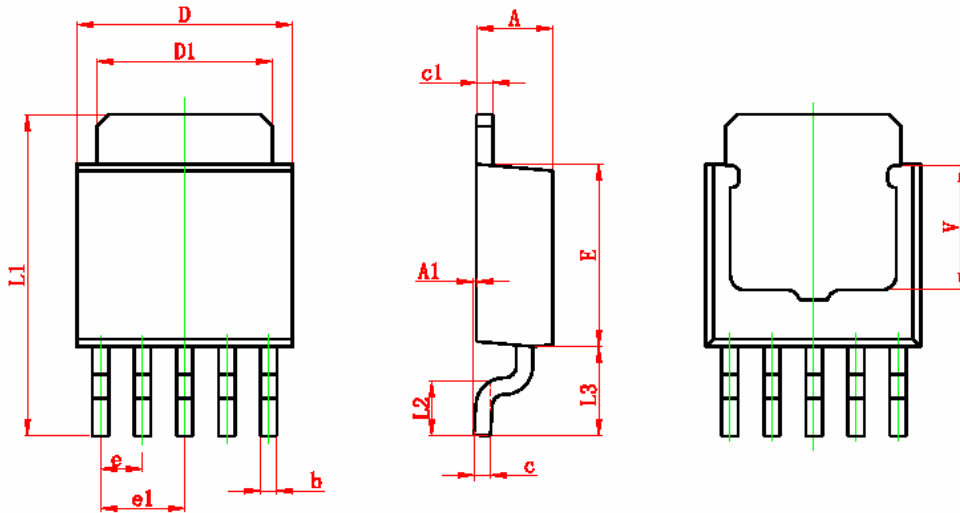
PACKAGE
TO-252-5L

Symbol	Dimensions in Millimeters		Dimensions in Inches	
	MIN	MAX	MIN	MAX
A	2.200	2.400	0.087	0.094
A1	0.000	0.127	0.000	0.005
B	0.400	0.600	0.016	0.024
C	0.430	0.580	0.017	0.023
c1	0.430	0.580	0.017	0.023
D	6.350	6.650	0.250	0.262
D1	5.200	5.400	0.205	0.213
E	5.400	5.700	0.213	0.224
E	1.270 TYP		0.050 TYP	
e1	2.540 TYP		1.000 TYP	
L1	9.500	9.900	0.374	0.390
L2	1.400	1.780	0.055	0.070
L3	2.550	2.900	0.100	0.114
V	3.800 REF		0.150 REF	

Preliminary

IMPORTANT NOTICE

ADDtek reserves the right to make changes to its products or to discontinue any integrated circuit product or service without notice, and advises its customers to obtain the latest version of relevant information to verify, before placing orders, that the information being relied on is current.

A few applications using integrated circuit products may involve potential risks of death, personal injury, or severe property or environmental damage. ADDtek integrated circuit products are not designed, intended, authorized, or warranted to be suitable for use in life-support applications, devices or systems or other critical applications. Use of ADDtek products in such applications is understood to be fully at the risk of the customer. In order to minimize risks associated with the customer's applications, the customer should provide adequate design and operating safeguards.

ADDtek assumes no liability to customer product design or application support. ADDtek warrants the performance of its products to the specifications applicable at the time of sale.

for KYOTATHU only Preliminary

ADDtek Corp.

9F, No. 20, Sec. 3, Bade Rd., Taipei, Taiwan, 105

TEL: 2-25700299

FAX: 2-25700196
