

ZXSC400EV2 USER GUIDE

DESCRIPTION

The ZXSC400 is voltage mode boost converter in SOT23-6 package. Its low feedback voltage allows the current in a chain of LEDs to be set and accurately monitored with a single resistor with minimal losses.

The ZXSC400EV2 is configured for 25W LED Driver applications using the ZXSC400 boost converter.

FEATURES

- Drives strings of 23 serially connected R, G & B LEDs at 350mA
- Typical efficiency of 85%
- Over-voltage Protection

APPLICATIONS

- LCD TV RGB Backlight
- High Power LED driving

ORDERING INFORMATION

ORDER NUMBER
ZXSC400EV2

Please note evaluation boards are subject to availability and qualified leads.

TYPICAL APPLICATION CIRCUIT

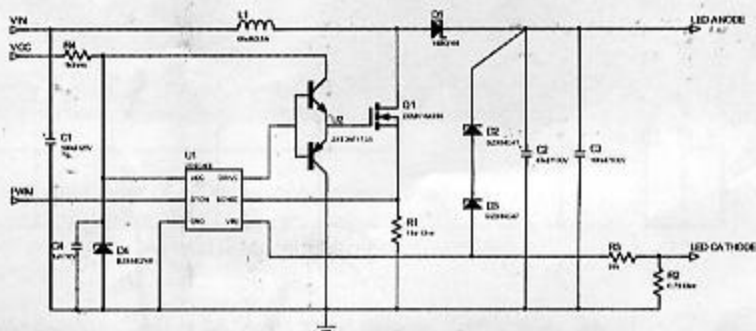

REFERENCE DESIGN

ZXSC400EV2 is configured to the reference design below. The target application is a 25W LED Driver typically White or RGB LED Driver for LCD TV backlighting.

The supply voltage is: $V_{IN}=24V$ and $V_{CC}=12V$ for the ZXSC400EV2.

For other reference designs or further applications information please refer to the ZXSC400 datasheet.

Schematic Diagram

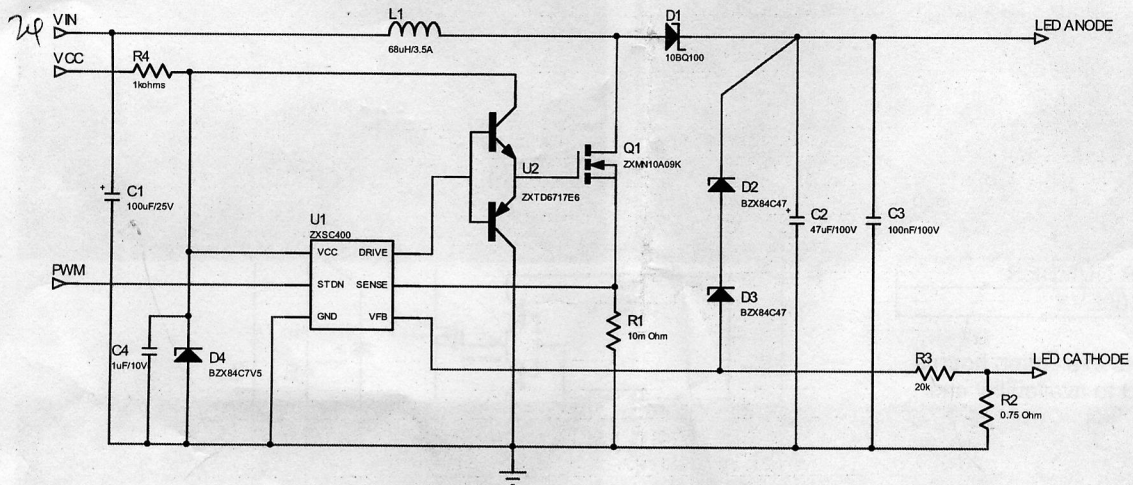

Materials List

Ref	Value	Package	Part Number	Manufacturer	Notes
U1	N/A	SOT23-6	ZXSC400E6	Zetex	Boost converter
U2	N/A	SOT23-6	ZXTD6717E6	Zetex	MOSFET gate driver
Q1	N/A	DPAK	ZXMN10A09K	Zetex	N-Channel MOSFET 100V
D1	100V/1A	SMB	10BQ100	IR	100V/1A Schottky diode
D2	47V	SOT23	BZX84C47	Philips	47V Zener diode
D3	47V	SOT23	BZX84C47	Philips	47V Zener diode
D4	7V5	SOT23	BZX84C7V5	Philips	7V5 Zener diode
L1	68uH/3.5A	N/A	DO5022P-683	Coilcraft	68uH/3.5A SMT Inductor
R1	10mΩ	1206		Generic	1206 5% tolerance
R2	0.75Ω	1206		Generic	1205 1% tolerance
R3	20kΩ	0805		Generic	0805 5% tolerance
R4	1kΩ	0805		Generic	0805 5% tolerance
C1	100μF/25V	E	EEVFK1E101P	Panasonic	SMT Electrolytic capacitor
C2	47μF/100V	H13	EEVFK2A470Q	Panasonic	SMT Electrolytic capacitor
C3	100nF/100V	1206		Generic	100nF/100V/1206/Y5V Ceramic capacitor
C4	1μF/10V	0805		Generic	1μF/10V/0805/Y5V Ceramic capacitor

ZXSC400EV2 OPERATION

Connection diagram

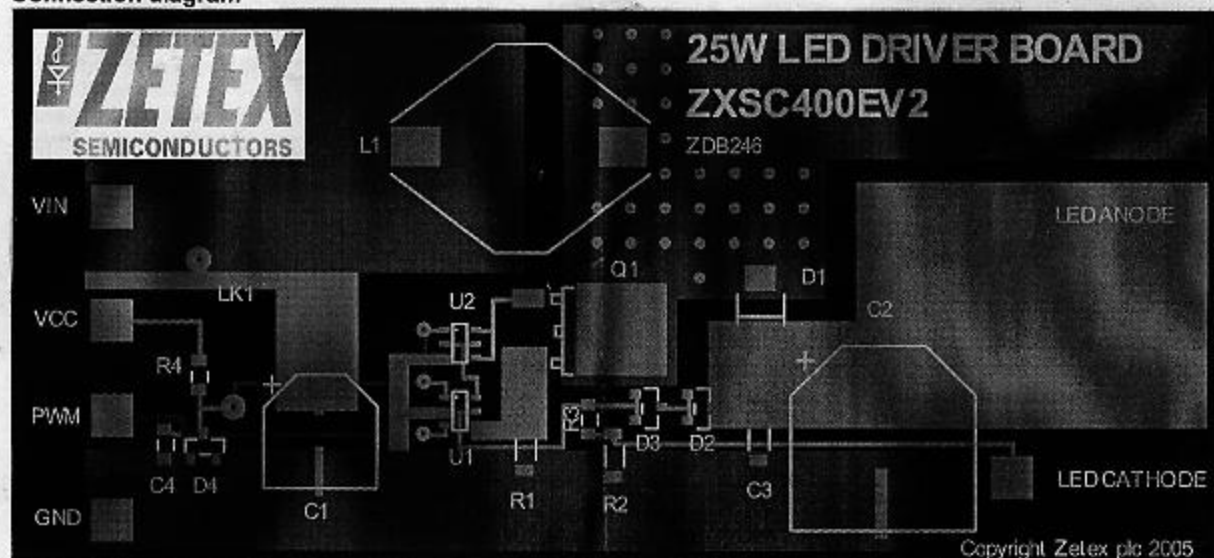

ZXSC400EV2 Set-up and Test

1. Connect V_{IN} and GND to positive and zero volts of PSU1 supply respectively.
2. Connect V_{CC} and GND to positive and zero volts of PSU2 supply respectively.
3. Connect LED chain to LED ANODE and LED CATHODE outputs on ZXSC400EV2
4. Set the PSU1 to 24V and PSU2 to 12V.
5. Turn on PSU1 and PSU2.
6. The LED chain should illuminate and be regulated at 350mA - **THIS IS A FUNCTIONAL EVAL BOARD.**

LED Dimming using the PWM Input.

By injecting a PWM signal on the PWM input and varying the duty cycle, LED current and hence LED brightness can be adjusted.

To implement this method of brightness control on the ZXLD1100EV2:

1. Connect a 10k Ω resistor between the drive pin of the ZXSC400 and GND.
2. Apply PWM signal with amplitude of between 0.7V and V_{CC} at a frequency of 100Hz to 1kHz (to eliminate LED flicker). The LED current and hence LED brightness is linearly proportional to the duty cycle ratio, so for brightness control adjust duty cycle ratio as necessary. For example, a 10% duty cycle equates to 10% of full LED brightness.

Note: It may be necessary to reduce to value of the output capacitor, C2, to optimize for a 1kHz PWM dimming signal. We recommend a value of 10 μ F/100V for the best compromise between PWM switching and LED current ripple at full power.

Layout considerations

PCB tracks should be kept as short as possible to minimize ground bounce, and the ground pin of the device should be soldered directly to the ground plane. It is particularly important to mount the coil and the input/output capacitors close to the device to minimize parasitic resistance and inductance, which will degrade efficiency. The FB pin is a high impedance input, so PCB track lengths to this should also be kept as short as possible to reduce noise pickup. Excess capacitance from the FB pin to ground should be avoided.

Below is the recommended layout of the ZXSC400EV2.

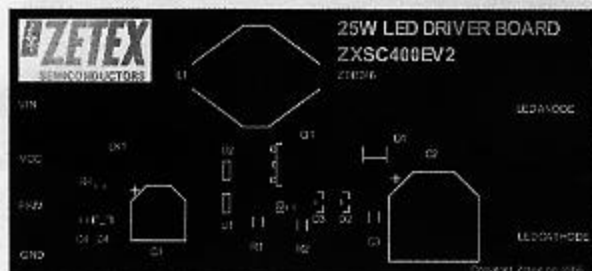

Top Silk

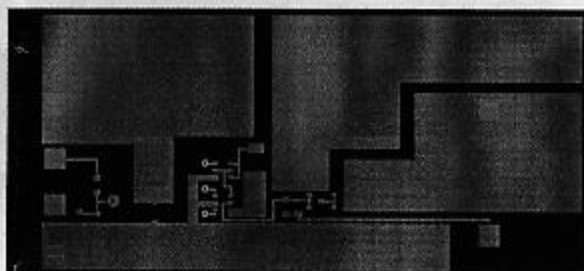

Top Copper



Bottom Copper

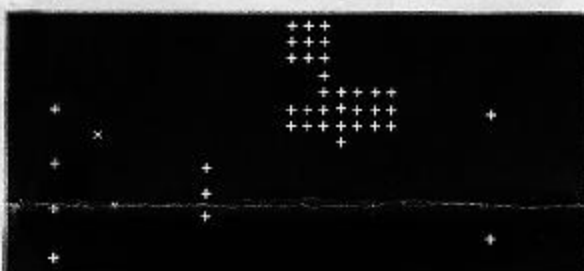

Drill File

© Zetex Semiconductors plc 2005

Europe Zetex GmbH Strelfeldstraße 19 D-81673 München Germany Telefon: (49) 89 45 49 49 0 Fax: (49) 89 45 49 49 49 email: europe.sales@zetex.com	The Americas Zetex Inc 700 Veterans Memorial Hwy Hauppauge, NY 11788 USA Telephone: (1) 631 360 2222 Fax: (1) 631 360 8222 email: usa.sales@zetex.com	Asia Zetex (Asia) Ltd 3701-04 Metroplaza Tower 1 Hing Fong Road, Kwai Fong Hong Kong Telephone: (852) 26100 611 Fax: (852) 24250 494 email: asia.sales@zetex.com	Corporate Headquarters Zetex Semiconductors plc Zetex Technology Park, Chadderton, OL9 9LL United Kingdom Telephone (44) 161 622 4444 Fax: (44) 161 622 4446 email: hq@zetex.com
---	---	--	--

These offices are supported by agents and distributors in major countries world-wide.

This publication is issued to provide outline information only which (unless agreed by the Company in writing) may not be used, applied or reproduced for any purpose or form part of any order or contract or be regarded as a representation relating to the products or services concerned. The Company reserves the right to alter without notice the specification, design, price or conditions of supply of any product or service.

For the latest product information, log on to www.zetex.com