



SMPS PROTOTYPE REPORT

19V-90W ADAPTER BOARD

WITH PFC

USING L6599 AND L6563

PRELIMINARY

Rev. 2

1. Scope

This document describes the performances of a reference board designed for Consumer applications like laptop PC adapters. High-efficiency and low stand-by power are main features of the circuit. This is a preliminary document that will be completed with more detail very soon.

2. Main characteristics

- UNIVERSAL INPUT MAINS RANGE: 90÷264Vac - frequency 45 to 65Hz
- OUTPUT VOLTAGE: 19V@4.7A continuous operation
- MAINS HARMONICS: ACC. TO EN61000-3-2
- ST-BY MAINS CONSUMPTION: TYP. 0.4W @230Vac
MAX 0.5W @265Vac
- OVERALL EFFICIENCY: BETTER THAN 90%
- EMI: MEETS EN55022-CLASS B
- SAFETY: MEETS EN60950
- LOW PROFILE DESIGN: 25MM MAXIMUM HEIGHT
- PCB SINGLE LAYER : 78x174 mm, MIXED PTH/SMT TECH.

3. Circuit description

The circuit is composed by two stages, a front-end PFC implementing the L6563 and a resonant DC/DC converter based on the new resonant controller, the L6599.

The PFC stage delivers a stable 400Vdc and provides for the reduction of the mains harmonic, allowing to meet the European norm EN61000-3-2. The controller is the L6563 (U1), working in transition mode and integrating all functions needed to control the PFC and interface the downstream resonant converter. The power stage of the PFC is a conventional boost converter, connected to the output of the rectifier bridge. It includes the coil L2, the diode D4 and the capacitor C9. The boost switch is represented by the power mosfet Q1. The L2 secondary winding (pins 8-10) is dedicated to provide to the L6563 the information about the PFC coil core demagnetization, necessary to the controller for the TM operation. The divider R1, R2 and R14 provides to the L6563 the information of the instantaneous voltage that is used to modulate the boost current, and to derive some further information like the average value of the AC line, used by the V_{FF} (voltage feed-forward) function. This function allows keeping almost independent the output voltage by the mains one. The divider R7, R8, R9, R10 is dedicated to sense the output voltage. The second divider R11, R12, R13 and R28 is dedicated to protect the circuit in case of voltage loop fail.

The second stage is a resonant converter, half bridge topology, working in ZVS. The controller is the new L6599, incorporating the necessary functions to drive properly the Half-bridge by a 50 percent fixed duty cycle with dead-time, working with variable frequency. Main features of the L6599 are a non linear soft-start, a new current protection pin allowing to program the hiccup mode timing, a dedicated pin for sequencing or brown-out (LINE) and a stand-by pin (STBY) allowing the burst mode operation at light load. The transformer uses the integrated magnetic approach, incorporating the resonant series inductance. Thus, no any external additional coil is needed for the resonance. The transformer configuration chosen for the secondary winding is centre tap, using two Schottky rectifiers, type STPS10L60FP. The feedback loop is implemented by means of a classical configuration using a TL431 to adjust the current in the optocoupler diode. The optocoupler transistor modulates the current from pin 4, so the frequency will change accordingly, thus achieving the output voltage regulation. The resistor R34 fixes the maximum operating frequency and the load at which the controller starts work in burst mode. In case of short circuit the current into the primary winding is sensed by the lossless circuit R41, C27, D11, D10, R39, and C25 and it is fed into the pin 6. In case of overload the voltage on pin #6 will overpass an internal threshold that will trigger a protection sequence via pin #2, keeping the current flowing in the circuit at a safe level. In case of output voltage loop fail the intervention of the zener diode connected to pin #8 (DIS) will activate the latched protection of the L6599. The DIS pin can be also activated by the L6563 via the PWM_LATCH pin in case of PFC loop fail. In both cases the circuit is disabled till a power recycle.

Figure 1: Electrical diagram

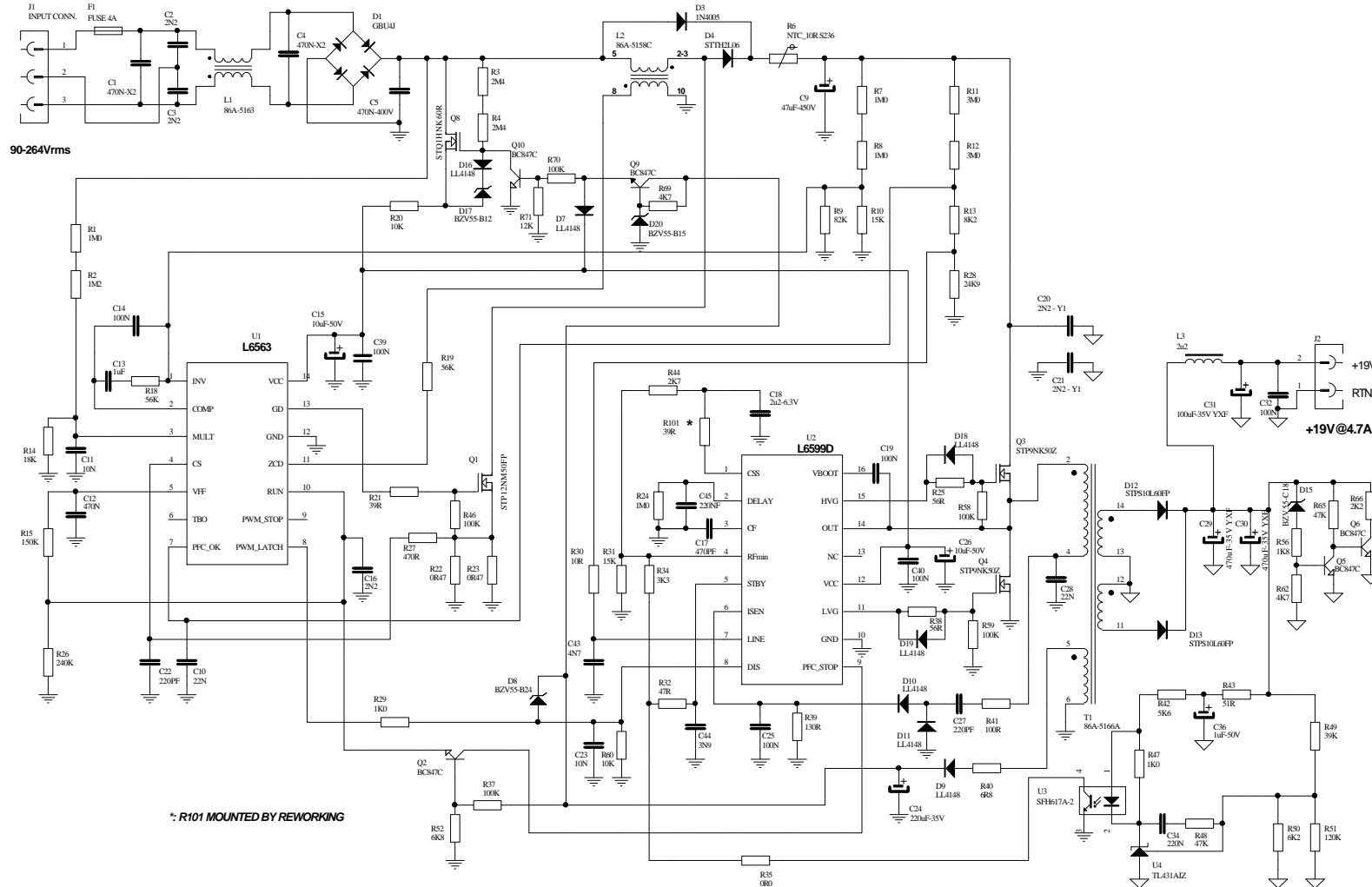

4. Test Results

1.1. Efficiency measurements

In the table below there are the output voltage measurements at nominal mains with different load conditions. Efficiency is then calculated.

Vin = 115Vac					Vin = 230Vac				
Vout	Iout	Pout	Pin	Eff.	Vout	Iout	Pout	Pin	Eff.
[V]	[A]	[W]	[W]	%	[V]	[A]	[W]	[W]	%
18.95	4.71	89.25	99.13	90.04	18.95	4.71	89.25	97.23	91.80
18.95	3.72	70.49	78.00	90.38	18.96	3.72	70.53	76.74	91.91
18.97	2.7	51.22	56.55	90.57	18.97	2.7	51.22	55.85	91.71
18.98	1.71	32.46	36.00	90.16	18.98	1.71	32.46	35.57	91.24
18.99	1.0	18.99	21.70	87.51	18.99	1.0	18.99	21.30	89.15
18.99	0.5	9.50	11.30	84.03	19.00	0.5	9.50	10.87	87.40
19.00	0.25	4.75	5.86	81.06	19.00	0.25	4.75	5.77	82.32

Table 1: Efficiency measurements

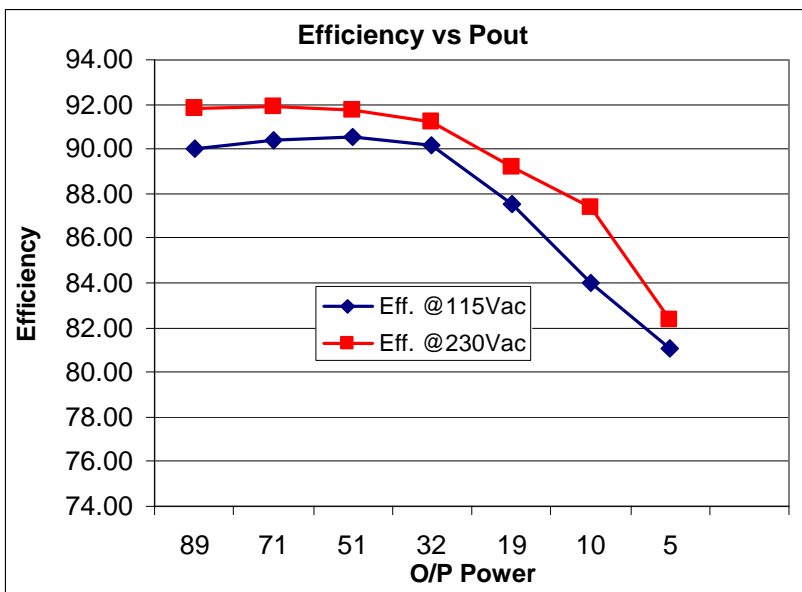

Figure 2: Efficiency vs. Pout

The global efficiency at full load has been measured even at the limits of the input voltage range, with good results:

Vin = 90Vac	Full Load	Pin = 100.5W	Efficiency = 88.9%
Vin = 264Vac	Full Load	Pin = 96.3W	Efficiency = 92.6%

5. Resonant stage operating waveforms

Figure 3: Resonant circuit primary side waveforms

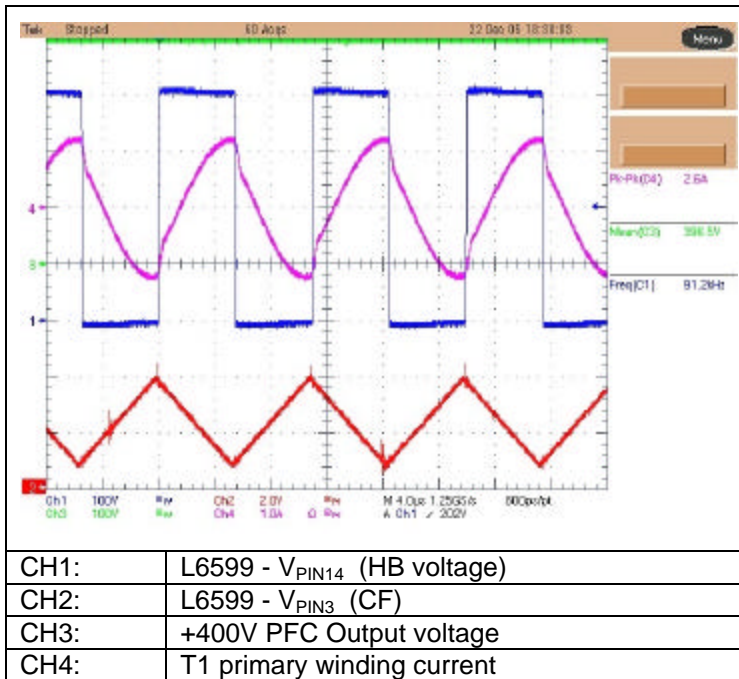

In figure 6 are reported some waveforms during steady state operation at full load of the circuit. The CH2 trace is the oscillator signal at pin #3 of the L6599, while the CH3 trace is the PFC output voltage, powering the resonant stage. The CH1 trace is the half bridge waveform, driving the resonant circuit. In the picture it is not evident, but the switching frequency is normally slightly modulated following the PFC 100Hz ripple that is rejected by the resonant control circuitry. The switching frequency has been chosen around 90KHz, in order to have a good trade off between transformer losses and its dimensions. The transformer primary current wave shape is the CH4 trace. As visible it is

almost sinusoidal, because the operating frequency is very close to the resonance of the leakage inductance and the resonant capacitor (C28). In this condition the circuit has a good margin for ZVS operations providing good efficiency and the sine wave shape provides for an EMI generation extremely low.

Figure 4: Resonant circuit secondary side waveforms

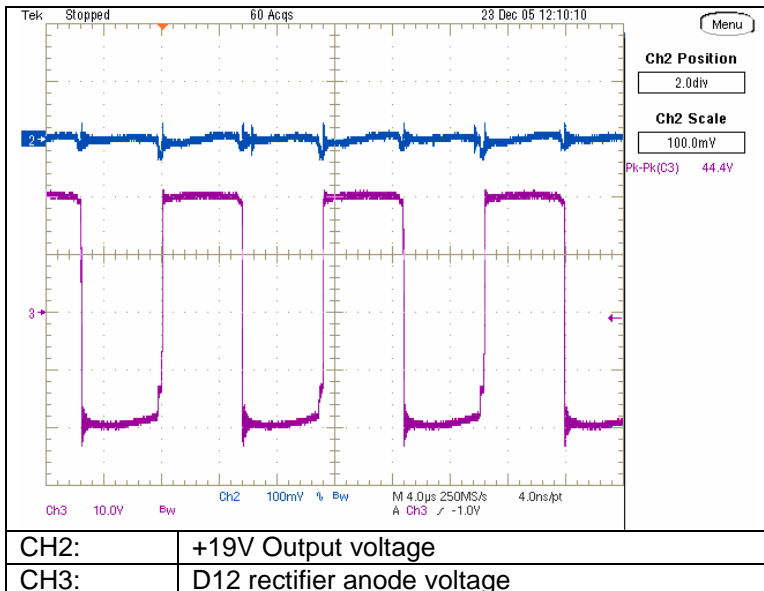

In figure 4 are represented some waveforms relevant to the secondary side: the rectifiers reverse voltage is measured by CH3 and the peak to peak value is indicated on the right of the picture. It is a bit higher than the theoretical value that would be $2(V_{out}+V_f)$, then about 40V. It is possible to notice there is a small ringing on the bottom side of the wave form, responsible for this difference. Thanks to the advantages of the resonant converter the high frequency ripple and noise of the output voltage is only 70mV (0.37%) including spikes, while the residual ripple at mains frequency is 130mV at maximum load and any

line condition.

1.2. Stand-by & No load power consumption

The circuit has been designed for light load and zero load operation, like during operation with load disconnected. The results are reported in the diagram of figure 6, here following. **The input power at zero load is always below 0.4W at any input mains voltage.**

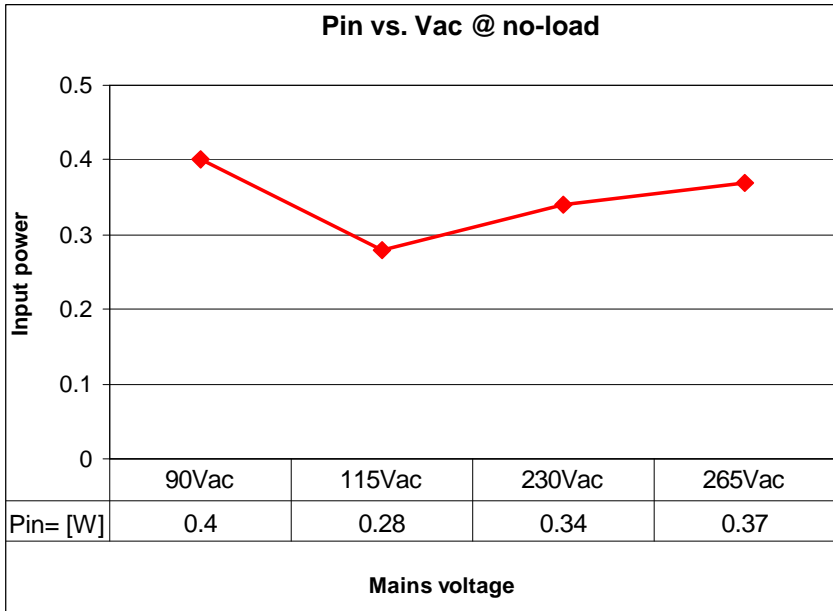

Figure 5: Input power without load vs. mains voltage

mains is very low. However, if the output voltage has a sudden load change both converters are ready to react immediately, thus avoiding output voltage drops. In table 2 are reported the measurements of the input power during operation at reduced output power. Even with this load condition the circuit efficiency is very good.

Figure 6: Resonant circuit, no load waveforms

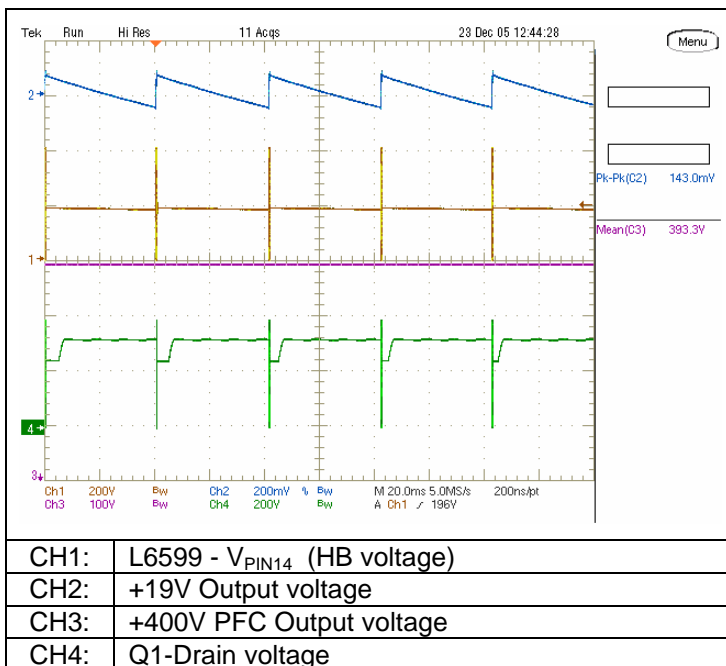

Table 2: Stand-by consumption

Thanks to the L6599 stand-by function, at light load conditions both the resonant converter and the PFC work skipping switching cycles, according to the load. Moreover, the L6599 via the PFC_STOP pin (#9) stops the operation of the L6563 during the burst mode off time. The result is visible in figure 6: the two converters are now working for a very short time, the output voltage is perfectly regulated at its nominal value, with only a small residual ripple over imposed (~140mV). Thanks to the burst mode and the reduced number of switching cycles and related losses, the input power drawn from the

Vin = 115Vac			
Vout	Iout	Pout	Pin
[V]	[mA]	[W]	[W]
19.01	80	1.5	3
19.01	53	1	2
19.01	27	0.5	1.08
19.01	13	0.25	0.66

Vin = 230Vac			
Vout	Iout	Pout	Pin
[V]	[A]	[W]	[W]
19.01	80	1.5	2.4
19.01	53	1	1.68
19.01	27	0.5	1
19.01	13	0.25	0.67

Short circuit protection

Figure 7: Output short circuit waveforms

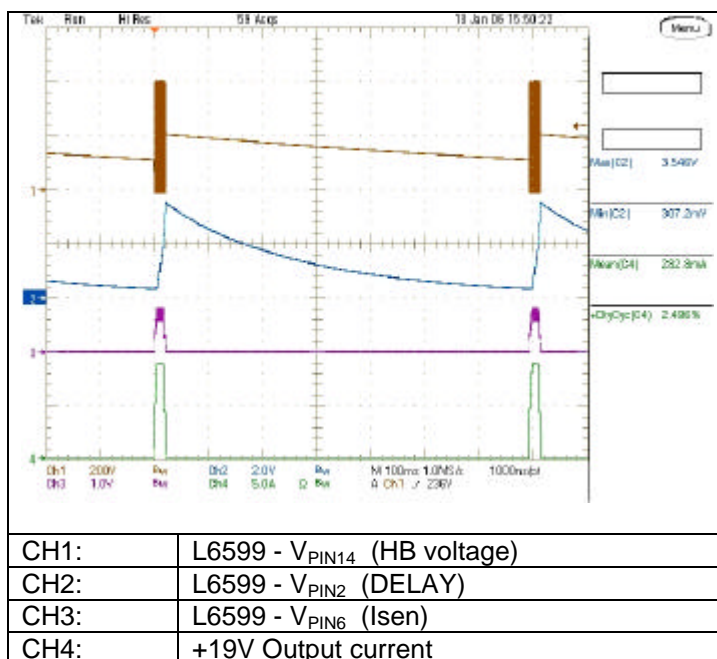

The L6599 is equipped with a current sensing input (pin #6, I_{SEN}) and a dedicated over current management system. The current flowing in the circuit is sensed and the signal is fed into the ISEN pin. It is internally connected to the input of a first comparator, referenced to 0.8V, and to that of a second comparator referenced to 1.5V. If the voltage externally applied to the pin by either circuit in figure 8 exceeds 0.8V the first comparator is tripped and this causes an internal switch to be turned on and discharge the soft-start capacitor C_{SS}. Under output short circuit, this operation results in a nearly constant peak primary current. With the L6599 the designer can program externally the maximum time (TSH) that the converter is allowed to run overloaded or under short circuit conditions. Overloads or short circuits lasting less than TSH will not cause any other

action, hence providing the system with immunity to short duration phenomena. If, instead, TSH is exceeded an overload protection (OLP) procedure is activated that shuts down the L6599 and, in case of continuous overload/short circuit, results in continuous intermittent operation with a user-defined duty cycle. This function is realized with the pin DELAY (#2), by means of a capacitor C45 and the parallel resistor R24 connected to ground. As the voltage on the ISEN pin exceeds 0.8V the first OCP comparator, in addition to discharging C_{SS}, turns on an internal current generator that via the DELAY pin charges C45. As the voltage on C45 is 3.5V, the L6599 stops switching and the PFC_STOP pin is pulled low. Also the internal generator is turned off, so that C45 will now be slowly discharged by R24. The IC will restart when the voltage on C45 will be less than 0.3V. Additionally, if the voltage on the ISEN pin reaches 1.5V for any reason (e.g. transformer saturation), the second comparator will be triggered, the L6599 will shutdown and the operation will be resumed after an on-off cycle.

The L6599 short circuit protection sequence described above is visible in the figure 7: the on off operation is controlled by the voltage on pin #2 (DELAY), providing for the hiccup mode of the circuit. Thanks to this control pin the designer can select the hiccup mode timing and thus keep the average output current at a safe level. Please note on the picture left side the very low mean current flowing in the shorted output, less than 0.3 A.

Over voltage protections

Both circuit stages, PFC and resonant are equipped with their own over voltage protection. The PFC controller L6563 is internally equipped with a dynamic and a static over voltage protection circuit sensing the error amplifier via the voltage divider dedicated to the feedback loop to sense the PFC output voltage. In case the internal threshold is exceeded the IC limits the voltage to a programmable, safe value. Moreover, in the L6563 there is an additional protection against loop failures using an additional divider (R11, R12, R13, R28) connected to a dedicated pin (PFC_OK, #7) protecting the circuit in case of loop failures or disconnection or deviation from the nominal value of the feedback loop divider. Hence the PFC output voltage is always under control and in case a fault condition is detected the PFC_OK circuitry will latch the L6563 operations and, by means of the PWM_LATCH pin (#8) it will latch the L6599 as well via the pin #8 (DIS). The pin DIS is also used to protect the resonant stage against over voltage or loop disconnections. In fact, the zener diode D8 connected to pin DIS senses the voltage and in case of open loop it will conduct and voltage on pin DIS will exceed the internal threshold. Then the IC will be immediately shut down and its consumption reduced at a low value. This state will be latched and will be necessary to let the voltage on the Vcc pin go below the UVLO threshold to reset the latch and restart the IC operation.

6. Start-up sequence

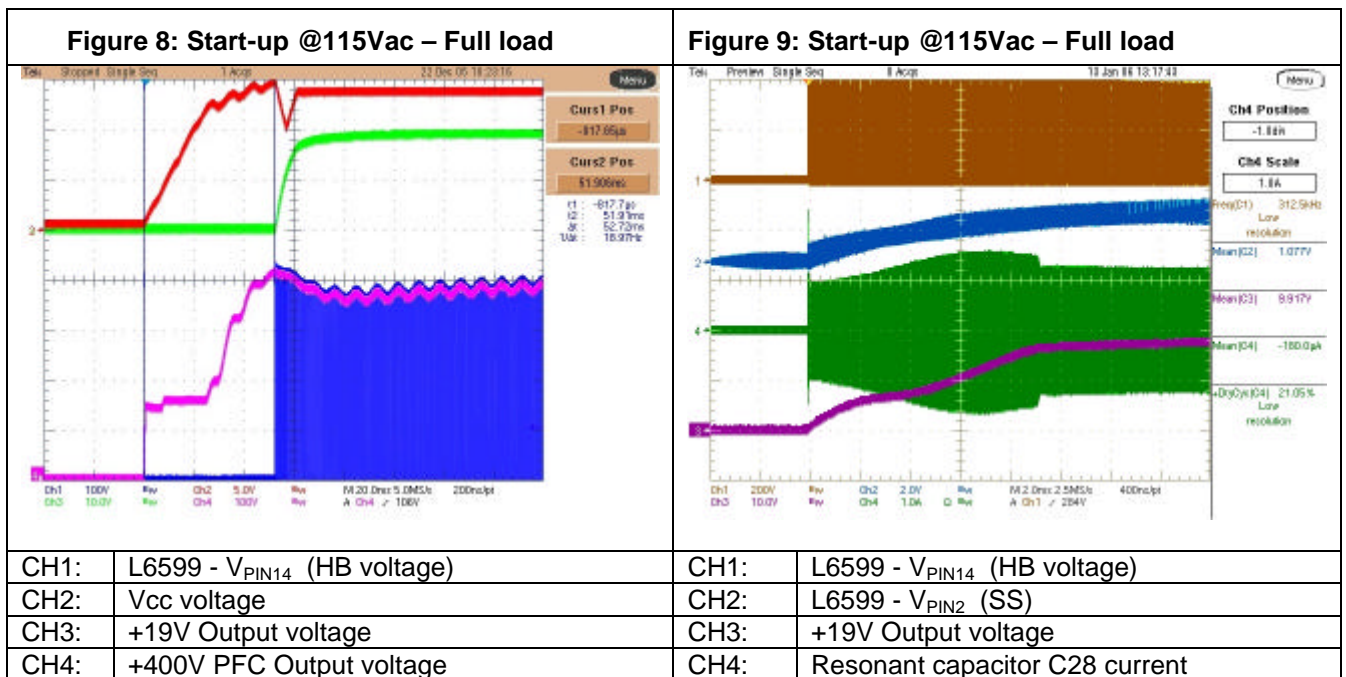

In figure 8 are reported the waveforms during the start at 90Vac and full load. It is possible to note the sequence of the two stages: at power on the L6563 and L6599 Vcc voltages increase up to the turn-on thresholds of the two ICs. The PFC starts and its output voltage increases from the mains rectified voltage to its nominal value, with a small overshoot. In the meantime the L6599 is kept inactive by the LINE pin (#7) until the PFC voltage reaches the threshold set by the divider R11, R12, R13, R28. As soon as it reaches the L6599 LINE pin threshold, the resonant starts to operate. Hence the output voltage rises according to the soft-start and reaches the nominal level. This sequence provides for the advantages of a perfect sequencing of the circuit at start-up with the PFC acting as master and avoids complex additional circuitry for the correct start-up of the circuit in all conditions. The circuit has been tested in all line and load conditions showing a correct start-up sequence. The used high voltage start-up circuit used avoids useless power dissipation during light load operation and provides for an almost constant wake-up time of the circuit.

Thermal tests

In order to check the design reliability, a thermal mapping by means of an IR Camera was done. Here below the thermal measures of the board, component side, at nominal input voltage are shown. Some pointers visible on the pictures have been placed across key components or components showing high temperature. The correlation between measurement points and components is indicated below, for both diagrams.

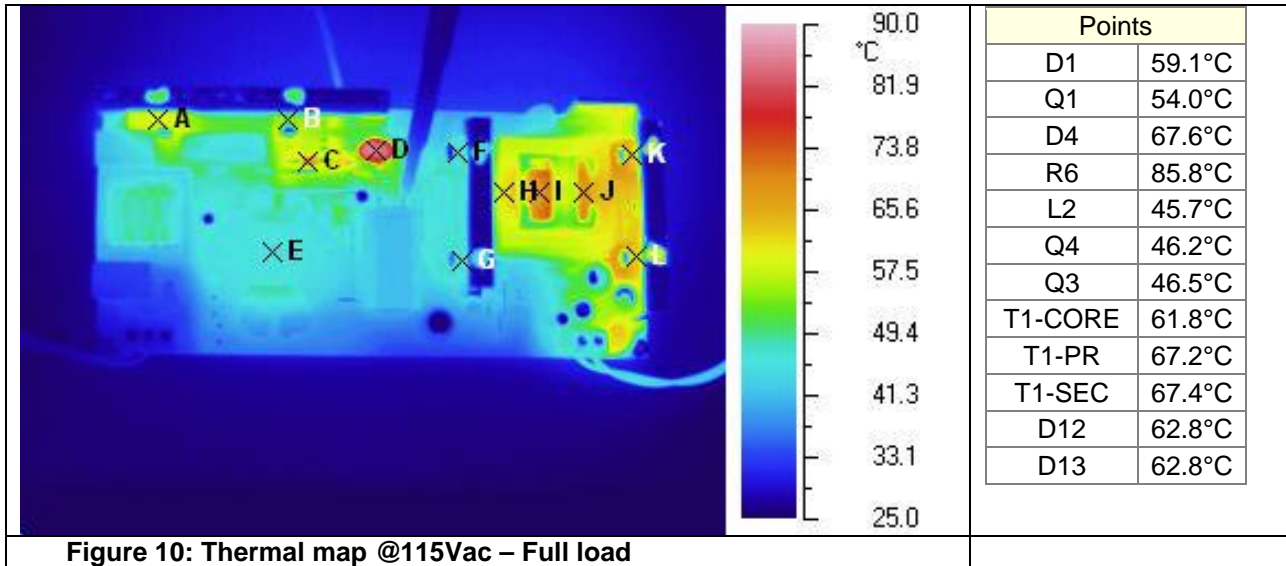

Figure 10: Thermal map @115Vac – Full load

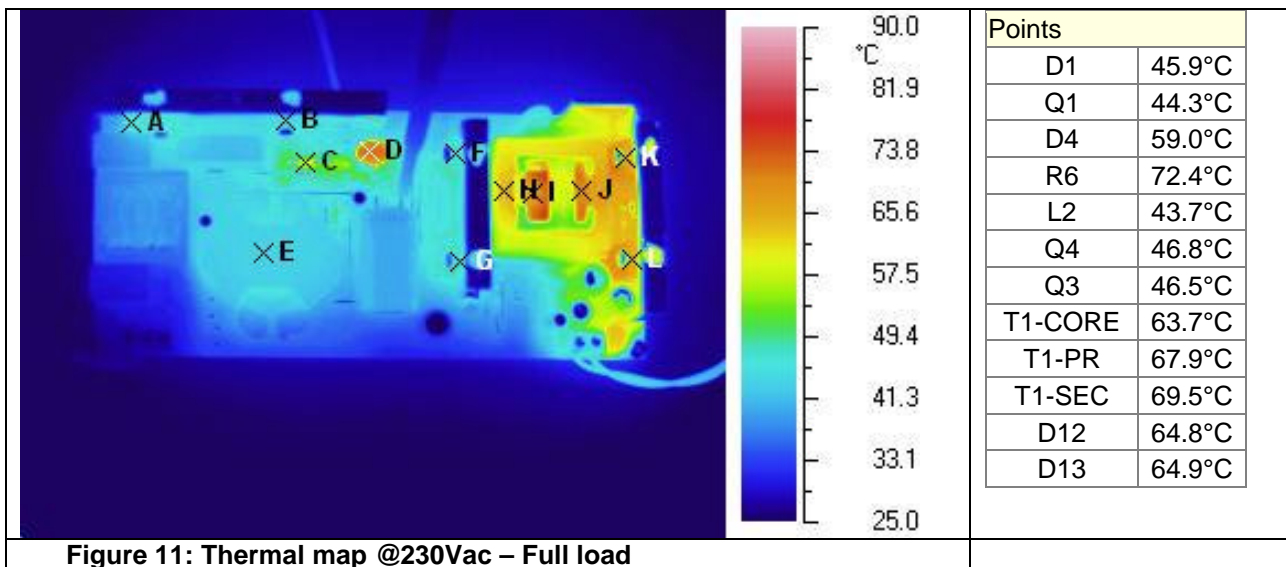

Figure 11: Thermal map @230Vac – Full load

All other components of the board are working within the temperature limits, assuring a reliable long term operation of the power supply.

Conducted emission pre-compliance test

The limits indicated on both diagrams at 115Vac and 230Vac are according to EN55022 Class-B. The measures have been done in peak detection mode.

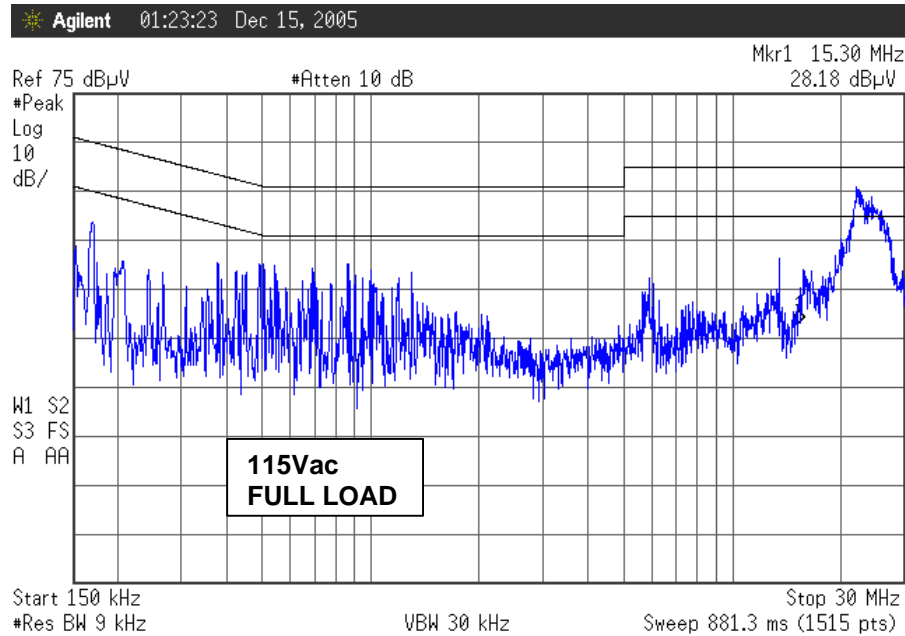

Figure 12: CE peak measure at 115Vac and full load

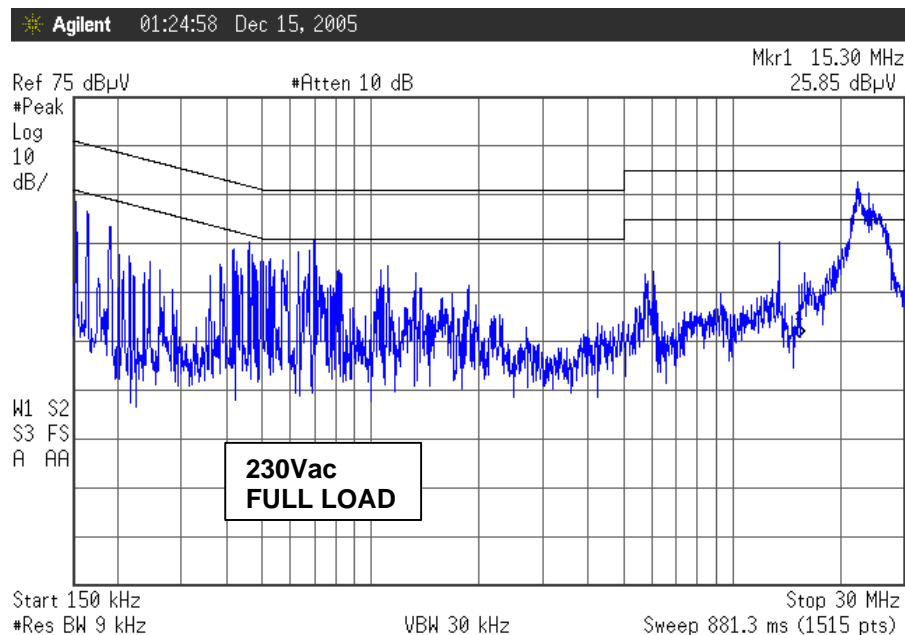

Figure 13: CE peak measure at 230Vac and full load

7. Bill of material

Des.	Part Type/ Part Value	Description	Supplier
C1	470N-X2	X2 FILM CAPACITOR - R46-I 3470--M1-	ARCOTRONICS
C10	22N	50V CERCAP - GENERAL PURPOSE	AVX
C11	10N	50V CERCAP - GENERAL PURPOSE	AVX
C12	470N	25V CERCAP - GENERAL PURPOSE	AVX
C13	1uF	25V CERCAP - GENERAL PURPOSE	AVX
C14	100N	50V CERCAP - GENERAL PURPOSE	AVX
C15	10uF-50V	ALUMINIUM ELCAP - YXF SERIES - 105°C	RUBYCON
C16	2N2	50V CERCAP - GENERAL PURPOSE	AVX
C17	470PF	50V - 5% - C0G - CERCAP	AVX
C18	2uF2-6.3V	25V CERCAP - GENERAL PURPOSE	AVX
C19	100N	50V CERCAP - GENERAL PURPOSE	AVX
C2	2N2	Y1 SAFETY CAP.	MURATA
C20	2N2 - Y1	DE1E3KX222M - Y1 SAFETY CAP.	MURATA
C21	2N2 - Y1	DE1E3KX222M - Y1 SAFETY CAP.	MURATA
C22	220PF	50V CERCAP - GENERAL PURPOSE	AVX
C23	10N	50V CERCAP - GENERAL PURPOSE	AVX
C24	220uF-35V	ALUMINIUM ELCAP - YXF SERIES - 105°C	RUBYCON
C25	100N	50V CERCAP - GENERAL PURPOSE	AVX
C26	10uF-50V	ALUMINIUM ELCAP - YXF SERIES - 105°C	RUBYCON
C27	220PF	500V CERCAP - 5MQ221KAAAA	AVX
C28	22N	630V - PHE450MA5220JR05	EVOX-RIFA
C29	470uF-35V YXF	ALUMINIUM ELCAP - YXF SERIES - 105°C	RUBYCON
C3	2N2	Y1 SAFETY CAP.	MURATA
C30	470uF-35V YXF	ALUMINIUM ELCAP - YXF SERIES - 105°C	RUBYCON
C31	100uF-35V YXF	ALUMINIUM ELCAP - YXF SERIES - 105°C	RUBYCON
C32	100N	50V CERCAP - GENERAL PURPOSE	AVX
C34	220N	50V CERCAP - GENERAL PURPOSE	AVX
C36	1uF-50V	ALUMINIUM ELCAP - YXF SERIES - 105°C	RUBYCON
C39	100N	50V CERCAP - GENERAL PURPOSE	AVX
C4	470N-X2	X2 FILM CAPACITOR - R46-I 3470--M1-	ARCOTRONICS
C40	100N	50V CERCAP - GENERAL PURPOSE	AVX
C43	4N7	50V CERCAP - GENERAL PURPOSE	AVX
C44	3N9	50V CERCAP - GENERAL PURPOSE	AVX
C45	220NF	25V CERCAP - GENERAL PURPOSE	AVX
C5	470N-400V	PHE426KD6470JR06L2 - POLYPROP. FILM CAP	EVOX-RIFA
C9	47uF-450V	ALUMINIUM ELCAP - TSUP SERIES - 85°C	PANASONIC
D1	GBU4J	SINGLE PHASE BRIDGE RECTIFIER	VISHAY
D10	LL4148	FAST SWITCHING DIODE	VISHAY
D11	LL4148	FAST SWITCHING DIODE	VISHAY
D12	STPS10L60FP	POWER SCHOTTKY RECTIFIER	STMICROELECTRONICS
D13	STPS10L60FP	POWER SCHOTTKY RECTIFIER	STMICROELECTRONICS
D15	BZV55-C18	ZENER DIODE	VISHAY
D16	LL4148	FAST SWITCHING DIODE	VISHAY
D17	BZV55-C12	ZENER DIODE	VISHAY
D18	LL4148	FAST SWITCHING DIODE	VISHAY

D19	LL4148	FAST SWITCHING DIODE	VISHAY
D20	BZV55-B15	ZENER DIODE	VISHAY
D3	1N4005	GENERAL PURPOSE RECTIFIER	VISHAY
D4	STTH2L06	ULTRAFAST HIGH VOLTAGE RECTIFIER	STMICROELECTRONICS
D7	LL4148	FAST SWITCHING DIODE	VISHAY
D8	BZV55-B24	ZENER DIODE	VISHAY
D9	LL4148	FAST SWITCHING DIODE	VISHAY
F1	FUSE 4A	FUSE T4A - TIME DELAY	WICHMANN
HS1		HEAT SINK FOR D1&Q1	DWG
HS2		HEAT SINK FOR Q3&Q4	DWG
HS3		HEAT SINK FOR D12&D13	DWG
J1	MKDS 1,5/ 3-5,08	PCB TERM. BLOCK, SCREW CONN.- 3 W.	PHOENIX CONTACT
J2	MKDS 1,5/ 2-5,08	PCB TERM. BLOCK, SCREW CONN.- 2 W.	PHOENIX CONTACT
L1	86A-5163	INPUT EMI FILTER	DELTA ELECTRONICS
L2	86A-5158C	PFC INDUCTOR	DELTA ELECTRONICS
L3	RFB0807-2R2	2u2 - RADIAL INDUCTOR	COILCRAFT
Q1	STP12NM50FP	N-CHANNEL POWER MOSFET	STMICROELECTRONICS
Q10	BC847C	NPN SMALL SIGNAL BJT	STMICROELECTRONICS
Q2	BC847C	NPN SMALL SIGNAL BJT	STMICROELECTRONICS
Q3	STP9NK50ZFP	N-CHANNEL POWER MOSFET	STMICROELECTRONICS
Q4	STP9NK50ZFP	N-CHANNEL POWER MOSFET	STMICROELECTRONICS
Q5	BC847C	NPN SMALL SIGNAL BJT	STMICROELECTRONICS
Q6	BC847C	NPN SMALL SIGNAL BJT	STMICROELECTRONICS
Q8	STQ1HNK60R	N-CHANNEL POWER MOSFET	STMICROELECTRONICS
Q9	BC847C	NPN SMALL SIGNAL BJT	STMICROELECTRONICS
R1	1M0	SMD STANDARD FILM RES - 1/4W - 5% - 250ppm/°C	BC COMPONENTS
R10	15K	SMD STANDARD FILM RES - 1/8W - 1% - 100ppm/°C	BC COMPONENTS
R11	3M0	MBB0207 AXIAL FILM RES - 0.4W - 1% - 50ppm/°C	BC COMPONENTS
R12	3M0	MBB0207 AXIAL FILM RES - 0.4W - 1% - 50ppm/°C	BC COMPONENTS
R13	8K2	SMD STANDARD FILM RES - 1/8W - 1% - 100ppm/°C	BC COMPONENTS
R14	18K	SMD STANDARD FILM RES - 1/4W - 5% - 250ppm/°C	BC COMPONENTS
R15	150K	SMD STANDARD FILM RES - 1/8W - 5% - 250ppm/°C	BC COMPONENTS
R18	56K	SMD STANDARD FILM RES - 1/8W - 5% - 250ppm/°C	BC COMPONENTS
R19	56K	SMD STANDARD FILM RES - 1/8W - 5% - 250ppm/°C	BC COMPONENTS
R2	1M2	SMD STANDARD FILM RES - 1/4W - 5% - 250ppm/°C	BC COMPONENTS
R20	10K	SMD STANDARD FILM RES - 1/4W - 5% - 250ppm/°C	BC COMPONENTS
R21	39R	SMD STANDARD FILM RES - 1/4W - 5% - 250ppm/°C	BC COMPONENTS
R22	0R47	SFR25 AXIAL STAND. FILM RES - 0.4W - 5% - 250ppm/°C	BC COMPONENTS
R23	0R47	SFR25 AXIAL STAND. FILM RES - 0.4W - 5% - 250ppm/°C	BC COMPONENTS
R24	1M0	SMD STANDARD FILM RES - 1/4W - 5% - 250ppm/°C	BC COMPONENTS
R25	56R	SMD STANDARD FILM RES - 1/8W - 5% - 250ppm/°C	BC COMPONENTS
R26	240K	SMD STANDARD FILM RES - 1/8W - 5% - 250ppm/°C	BC COMPONENTS
R27	470R	SMD STANDARD FILM RES - 1/4W - 5% - 250ppm/°C	BC COMPONENTS
R28	24K9	SMD STANDARD FILM RES - 1/8W - 1% - 100ppm/°C	BC COMPONENTS
R29	1K0	SMD STANDARD FILM RES - 1/4W - 5% - 250ppm/°C	BC COMPONENTS
R3	2M4	SMD STANDARD FILM RES - 1/4W - 5% - 250ppm/°C	BC COMPONENTS
R30	10R	SMD STANDARD FILM RES - 1/8W - 5% - 250ppm/°C	BC COMPONENTS
R31	15K	SMD STANDARD FILM RES - 1/8W - 1% - 100ppm/°C	BC COMPONENTS
R32	47R	SMD STANDARD FILM RES - 1/4W - 5% - 250ppm/°C	BC COMPONENTS
R34	3K3	SMD STANDARD FILM RES - 1/4W - 5% - 250ppm/°C	BC COMPONENTS

R35	0R0	SMD STANDARD FILM RES - 1/8W - 5% - 250ppm/°C	BC COMPONENTS
R37	100K	SMD STANDARD FILM RES - 1/4W - 5% - 250ppm/°C	BC COMPONENTS
R38	56R	SMD STANDARD FILM RES - 1/8W - 5% - 250ppm/°C	BC COMPONENTS
R39	130R	SMD STANDARD FILM RES - 1/4W - 5% - 250ppm/°C	BC COMPONENTS
R4	2M4	SMD STANDARD FILM RES - 1/4W - 5% - 250ppm/°C	BC COMPONENTS
R40	6R8	SFR25 AXIAL STAND. FILM RES - 0.4W - 5% - 250ppm/°C	BC COMPONENTS
R41	100R	SFR25 AXIAL STAND. FILM RES - 0.4W - 5% - 250ppm/°C	BC COMPONENTS
R42	5K6	SMD STANDARD FILM RES - 1/4W - 5% - 250ppm/°C	BC COMPONENTS
R43	51R	SMD STANDARD FILM RES - 1/8W - 5% - 250ppm/°C	BC COMPONENTS
R44	2K7	SMD STANDARD FILM RES - 1/4W - 5% - 250ppm/°C	BC COMPONENTS
R46	100K	SMD STANDARD FILM RES - 1/8W - 5% - 250ppm/°C	BC COMPONENTS
R47	1K0	SMD STANDARD FILM RES - 1/8W - 5% - 250ppm/°C	BC COMPONENTS
R48	47K	SMD STANDARD FILM RES - 1/8W - 5% - 250ppm/°C	BC COMPONENTS
R49	39K	SMD STANDARD FILM RES - 1/4W - 5% - 250ppm/°C	BC COMPONENTS
R50	6K2	SMD STANDARD FILM RES - 1/8W - 1% - 100ppm/°C	BC COMPONENTS
R51	120K	SMD STANDARD FILM RES - 1/8W - 1% - 100ppm/°C	BC COMPONENTS
R52	6K8	SMD STANDARD FILM RES - 1/4W - 5% - 250ppm/°C	BC COMPONENTS
R53	0R0	0R0 JUMPER	BC COMPONENTS
R54	0R0	0R0 JUMPER	BC COMPONENTS
R55	0R0	0R0 JUMPER	BC COMPONENTS
R56	1K8	SMD STANDARD FILM RES - 1/8W - 5% - 250ppm/°C	BC COMPONENTS
R57	0R0	0R0 JUMPER	BC COMPONENTS
R58	100K	SMD STANDARD FILM RES - 1/8W - 5% - 250ppm/°C	BC COMPONENTS
R59	100K	SMD STANDARD FILM RES - 1/8W - 5% - 250ppm/°C	BC COMPONENTS
R6	NTC_10R S236	NTC RESISTOR P/N B57236S0100M000	EPCOS
R60	10K	SMD STANDARD FILM RES - 1/4W - 5% - 250ppm/°C	BC COMPONENTS
R62	4K7	SMD STANDARD FILM RES - 1/8W - 5% - 250ppm/°C	BC COMPONENTS
R65	47K	SMD STANDARD FILM RES - 1/8W - 5% - 250ppm/°C	BC COMPONENTS
R66	2K2	SMD STANDARD FILM RES - 1/4W - 5% - 250ppm/°C	BC COMPONENTS
R69	4K7	SMD STANDARD FILM RES - 1/8W - 5% - 250ppm/°C	BC COMPONENTS
R7	1M0	MBB0207 AXIAL FILM RES - 0.4W - 1% - 50ppm/°C	BC COMPONENTS
R70	100K	SMD STANDARD FILM RES - 1/8W - 5% - 250ppm/°C	BC COMPONENTS
R71	12K	SMD STANDARD FILM RES - 1/4W - 1% - 100ppm/°C	BC COMPONENTS
R72	0R0	0R0 JUMPER	BC COMPONENTS
R8	1M0	MBB0207 AXIAL FILM RES - 0.4W - 1% - 50ppm/°C	BC COMPONENTS
R9	82K	SMD STANDARD FILM RES - 1/8W - 1% - 100ppm/°C	BC COMPONENTS
R101 [1]	39R	SMD STANDARD FILM RES - 1/8W - 5% - 250ppm/°C	BC COMPONENTS
T1	86A-5166A	RESONANT POWER TRANSFORMER	DELTA ELECTRONICS
U1	L6563	TRANSITION-MODE PFC CONTROLLER	STMICROELECTRONICS
U2	L6599D	HIGH VOLTAGE RESONANT CONTROLLER	STMICROELECTRONICS
U3	SFH617A-2	OPTOCOUPLER	INFINEON
U4	TL431AIZ	PROGRAMMABLE SHUNT VOLTAGE REFERENCE	STMICROELECTRONICS

[1]: R101 MOUNTED BY REWORKING ON PCB

8. PFC COIL SPECIFICATION

- APPLICATION TYPE: *Consumer, Home Appliance*
- TRANSFORMER TYPE: *Open*
- COIL FORMER: *Vertical type, 6+6 pins*

- MAX. TEMP. RISE: *45 °C*
- MAX. OPERATING AMBIENT TEMP.: *60 °C*
- MAINS INSULATION: *N.A.*

ELECTRICAL CHARACTERISTICS

- CONVERTER TOPOLOGY: *Boost, Transition mode*
- CORE TYPE: *RM14 – PC40 or equivalent*

- MIN. OPERATING FREQUENCY: *20 KHz*
- TYPICAL OPERATING FREQ:
- PRIMARY INDUCTANCE: *700 mH ±10% @1KHz – 0.25V* [1]
- PEAK PRIMARY CURRENT: *5 Apk*
- RMS PRIMARY CURRENT: *1.8 Arms*

[1]: Measured between pins #2 & #5

ELECTRICAL DIAGRAM

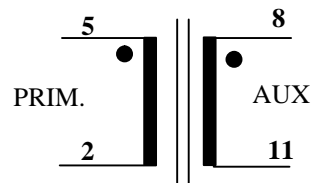

WINDING CHARACTERISTICS

PINS:	WINDING	RMS CURRENT:	NUMBER OF TURNS	WIRE TYPE
5 - 2	PRIMARY	1.8 A _{RMS}	53	STRANDED 7 x φ0.28 mm
8 - 11	AUX [1]	0.05 A _{RMS}	4 SPACED	TBD

[1]: Aux winding is wound on top of primary winding

MECHANICAL ASPECT AND PIN NUMBERING

MAXIMUM HEIGHT FROM PCB: 22 mm

COIL FORMER TYPE: VERTICAL, 6+6 PINS

PIN DISTANCE: 5.08 mm

PINS #1, 3, 4, 6, 7, 9, 10 are removed – Pin 9 is for polarity key.

- EXTERNAL COPPER SHIELD: Around the ferrite core and including the coil former. Height is 7mm. Connected by a solid wire soldered to pin 11.

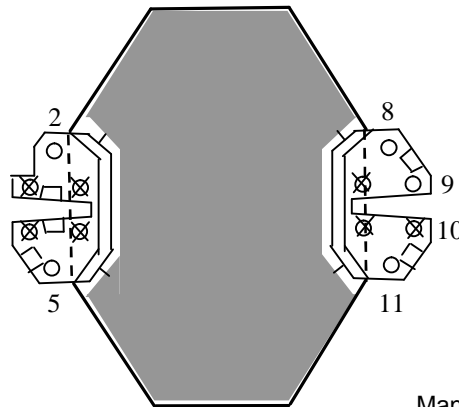

Manufacturer:
P/N:

DELTA ELECTRONICS
86A-5158C

BOTTOM VIEW

9. RESONANT POWER TRANSFORMER

- APPLICATION TYPE: *Consumer, Home Appliance*
- TRANSFORMER TYPE: *Open*
- COIL FORMER: *Horizontal type, 7+7 pins, 2 Slots*

- MAX. TEMP. RISE: *45 °C*
- MAX. OPERATING AMBIENT TEMP.: *60 °C*
- MAINS INSULATION: *ACC. WITH EN60065*

ELECTRICAL CHARACTERISTICS

- CONVERTER TOPOLOGY: *Half-bridge, resonant*
- CORE TYPE: *EER28L – PC40 or equivalent*
- MIN. OPERATING FREQUENCY: *60 KHz*
- TYPICAL OPERATING FREQ: *100 KHz*
- PRIMARY INDUCTANCE: *810 mH ±10% @1KHz – 0.25V* [1]
- LEAKAGE INDUCTANCE: *200 mH ±10% @1KHz – 0.25V* [1]-[2]

[1]: Measured between pins 1-4

[2]: Measured between pins 1-4 with ONLY a secondary winding shorted

• **ELECTRICAL DIAGRAM**

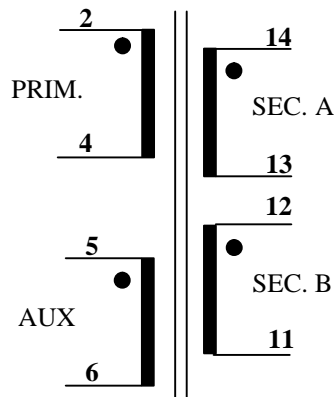

• **WINDING CHARACTERISTICS**

PINS:	WINDING	RMS CURRENT:	NUMBER OF TURNS	WIRE TYPE
2 - 4	PRIMARY	1 A _{RMS}	60	MULTISTRAND -TBD
14 - 13	SEC. A [1]	4 A _{RMS}	6	MULTISTRAND -TBD
12 - 11	SEC. B [1]	4 A _{RMS}	6	MULTISTRAND -TBD
5-6	AUX [2]	0.05 A _{RMS}	5 SPACED	TBD

[1]: Secondary windings A and B must be wound in parallel

[2]: Aux winding is wound on top of primary winding

• **MECHANICAL ASPECT AND PIN NUMBERING**

MAXIMUM HEIGHT FROM PCB: 22 mm

COIL FORMER TYPE: HORIZONTAL, 7+7 PINS (PIN 1&7 ARE REMOVED)

PIN DISTANCE: 5mm

ROW DISTANCE: 30 mm

PIN LAY-OUT, TOP VIEW

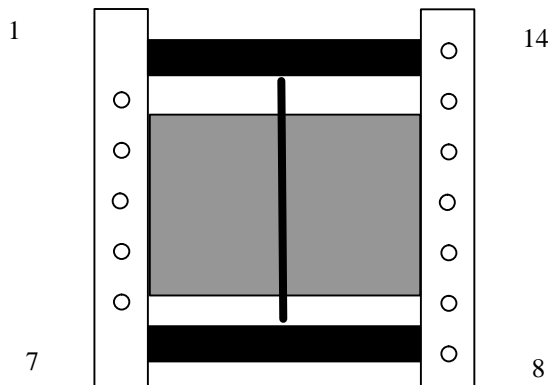

Manufacturer: DELTA ELECTRONICS
P/N: 86A-5166A