

## SWITCHING BOOST REGULATOR

### GENERAL DESCRIPTION

The **FP6201** is a boost topology of switching regulator for wide operating voltage applications field. The **FP6201** includes a high current N-MOSFET, high precision reference (0.5V) for comparing output voltage with feedback amplifier, an internal dead-time control and oscillator for controlling the maximum duty cycle and PWM frequency, and has power on programmable soft start time and short circuit NMOS turn-off and auto re-start protection functions.

### FEATURES

- Precision feedback reference voltage: 0.5V (2%)
- Wide supply voltage operating range: 3.0V to 20V
- Low current consumption: 5.5mA
- Internal fixed oscillator frequency: Typ. 500KHz
- Programmable Soft-Start function (SS)
- Short Circuit Shutdown and Auto Re-start function(ARSCP)
- Built-in N-MOSFET for 2A loading capability
- Package: SOP8

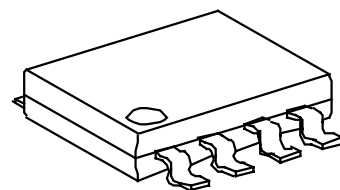

SOP8

### TYPICAL APPLICATION

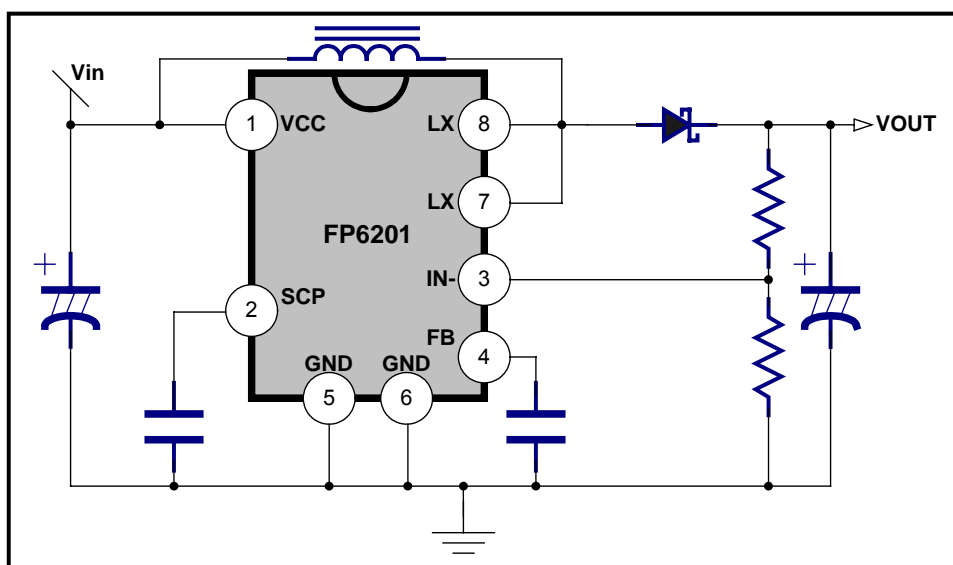

## FUNCTIONAL BLOCK DIAGRAM

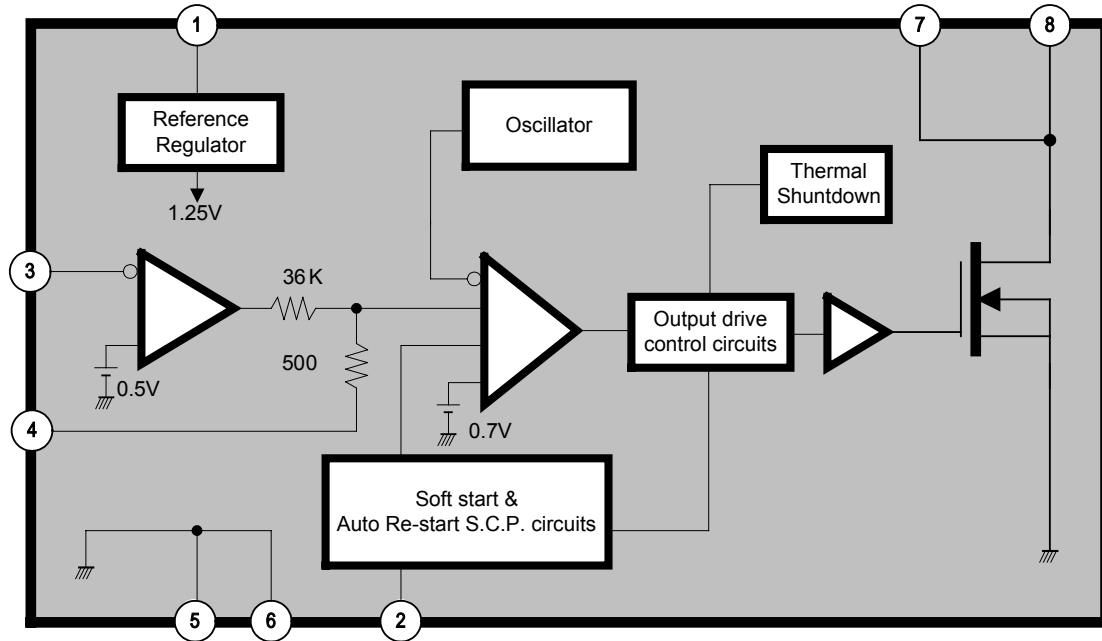

### MARK VIEW

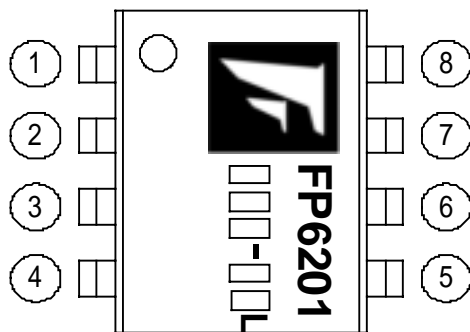

### PIN DESCRIPTION

Name	No.	I/O	Description
VCC	1	P	IC Power Supply
SS/SCP	2	I	Connecting with a Soft-start & ARSCP timing capacitor
IN-	3	I	Error Amplifier Inverting Input
FB	4	O	Error Amplifier Compensation Output
GND	5	P	IC Ground
	6		
LX	7	I	NMOS High Current Drain Input
	8		

## ORDER INFORMATION

Part Number	Operating Temperature	Package	Description
FP6201D-LF	-10°C ~ +85°C	SOP8	Tube
FP6201DR-LF	-10°C ~ +85°C	SOP8	Tape & Reel

## IC DATE CODE DISTINGUISH

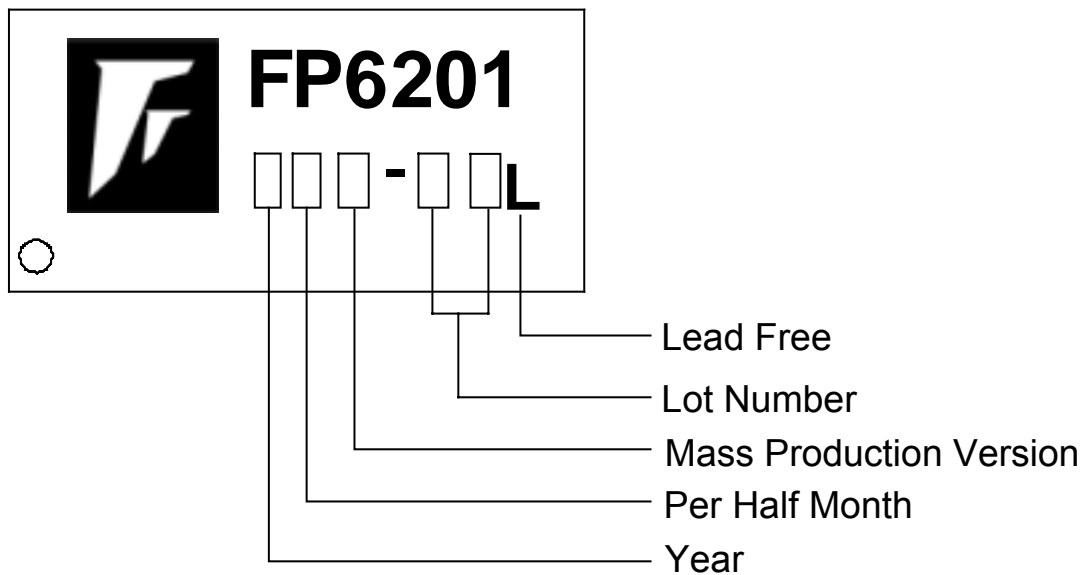

### FOR EXAMPLE:

January            A (Front Half Month), B (Last Half Month)  
 February           C, D  
 March              E, F              -----And so on

The printing ink of the lot number is a last two numbers of one wafer lot:

### For Example:

A3311C62  
 ─────────▶ Lot Number

## ABSOLUTE MAXIMUM RATINGS

Power supply voltage	-----	+20V
NMOS Drain sink current	-----	+3A
Error amplifier inverting input	-----	-0.3V~+1.2V
Allowable dissipation		
SOP8 Ta +25	-----	650mW
Operating temperature	-----	-10 +85
Storage temperature	-----	-55 +125
SOP8 Lead Temperature (soldering, 10 sec)	-----	+260

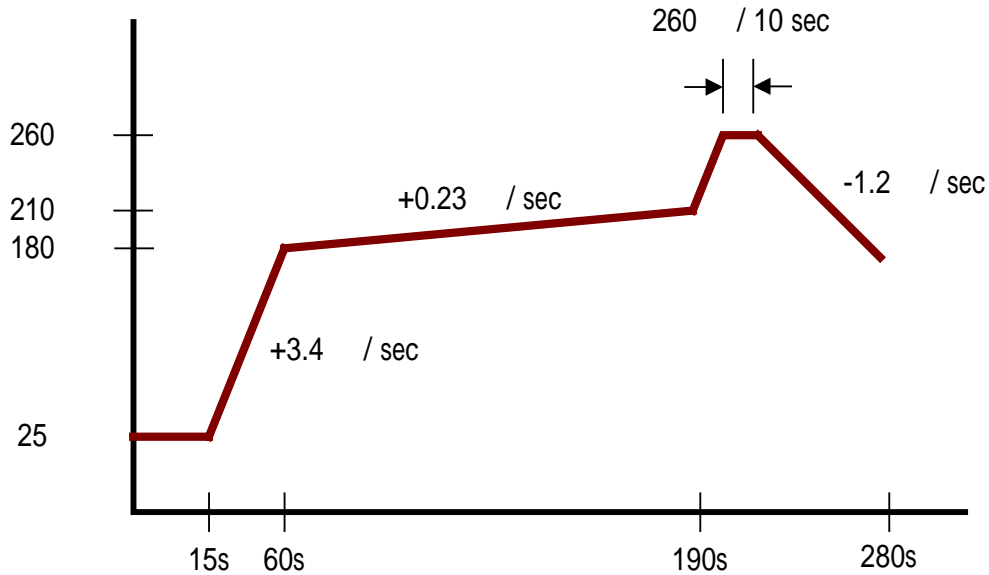

**FP6201 Lead Free Soldering Curve**

## DC ELECTRICAL CHARACTERISTICS

### Reference

PARAMETER	SYMBOL	TEST CONDITIONS	MIN	TYP	MAX	UNIT
Output voltage	$V_{REF}$	COMP connected to FB	0.490	0.5	0.510	V
Input regulation	$V_{REF}$	$V_{CC} = 3.0\text{ V to }20\text{ V}$		2	12.5	mV
Output voltage change with temperature	$V_{REF} / V_{REF}$	$T_A = -10\text{ to }25$		1	2	%
		$T_A = 25\text{ to }85$		1	2	

### Soft Start section (S.S.)

PARAMETER	SYMBOL	TEST CONDITIONS	MIN.	TYP.	MAX.	UNIT
S.S. Source current	$I_{SS}$	$V_{SS} = 0\text{ V}$	-15	-10	-7	$\mu\text{ A}$
Soft start threshold voltage	$V_{SST}$	--	0.8	0.9	1.0	V

### Short Circuit Protection section (S.C.P.)

PARAMETER	SYMBOL	TEST CONDITIONS	MIN.	TYP.	MAX.	UNIT
S.C.P. source current	$I_{SCP}$	$V_{SCP} = 0\text{ V}$	-15	-10	-7	$\mu\text{ A}$
SCP re-start / hold time	$T_{RS} / T_{HOLD}$	$V_{comp} > 0.8\text{ V}$		1/20		-
S.C.P. threshold voltage	$V_{SCP}$	$V_{FB} > 450\text{ mV}$	0.9	1.0	1.1	V
	$V_{SB}$	$V_{FB} < 450\text{ mV}$		0.1	0.15	

### Oscillator section

PARAMETER	SYMBOL	TEST CONDITIONS	MIN.	TYP.	MAX.	UNIT
Oscillation frequency	f		400	500	600	KHz
Frequency change with voltage	$\Delta f / \Delta V$	$V_{CC} = 4\text{ V to }15\text{ V}$	-	5		%
Frequency change with temperature	$\Delta f / \Delta T$	$T_a = -10\text{ to }85$	-	5	-	%

## DC ELECTRICAL CHARACTERISTICS (Cont.)

### Error Amplifier section

PARAMETER		SYMBOL	TEST CONDITIONS	MIN.	TYP.	MAX.	UNIT
Input threshold voltage		$V_{IN-}$	$V_{FB}=450mV$	490	500	510	mV
$V_T$ change with voltage		$\Delta V_{IN-} / \Delta V$	$V_{CC}=3V$ to $20V$	-	5	20	mV
$V_T$ change with temperature		$\Delta V_{IN-} / \Delta T$	$T_a = -10$ to $85$	-	1	-	%
Input bias current		$I_B$	--	-1.0	-0.2	1.0	$\mu A$
Voltage Gain		$A_V$	--	-	100	-	V/V
Frequency bandwidth		BW	$A_v=0$ dB	-	6	-	MHz
Output voltage Swing	Positive	$V_{POS}$	$V_{IN-}=0.3V$	0.78	0.87	-	V
	Negative	$V_{NEG}$	$V_{IN-}=0.7V$	-	0.05	0.2	
Output source current		$I_{SOURCE}$	$V_{FB}=450mV$	-	-45	-30	$\mu A$
Output sink current		$I_{SINK}$		30	45	-	$\mu A$

### Idle Period Adjustment section

PARAMETER	SYMBOL	TEST CONDITIONS	MIN.	TYP.	MAX.	UNIT
Maximum duty cycle	$T_{DUTY}$	$V_{IN-} = 0.2V$	85		95	%

### Total device section

PARAMETER	SYMBOL	TEST CONDITIONS	MIN.	TYP.	MAX.	UNIT
Average supply current	$I_{AVE}$	$V_{CC}=4.0V \sim 20V$	-	5.0	10	mA

### Output section

PARAMETER	SYMBOL	TEST CONDITIONS	MIN.	TYP.	MAX.	UNIT
NMOS D-S voltage	$V_{DSS}$	$V_{FB}=0.1V$		-25	-	V
NMOS source current	$I_D$			-2		A
NMOS On resistance	$R_{DS(ON)}$	$V_{CC}=-4.5.0V, V_{IN-}=0V$			120	m
		$V_{CC}=-10V, V_{IN-}=0V$			75	
Output leakage current	$I_L$	SCP active		5	-	$\mu A$

## TYPICAL CHATACTERISTICS

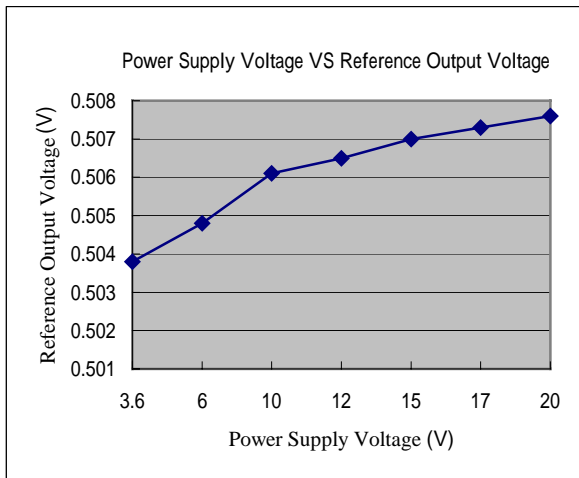

Figure 1

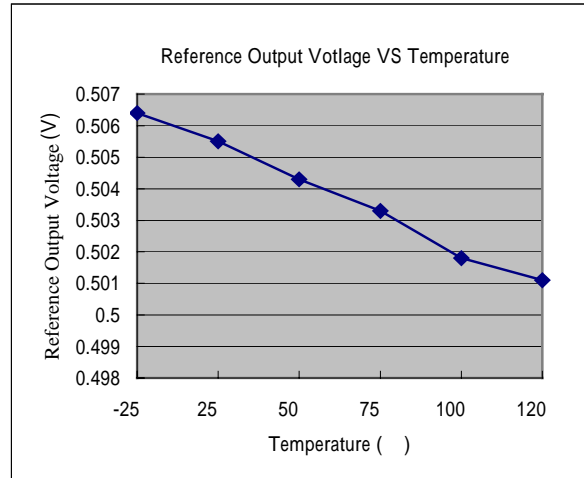

Figure 2

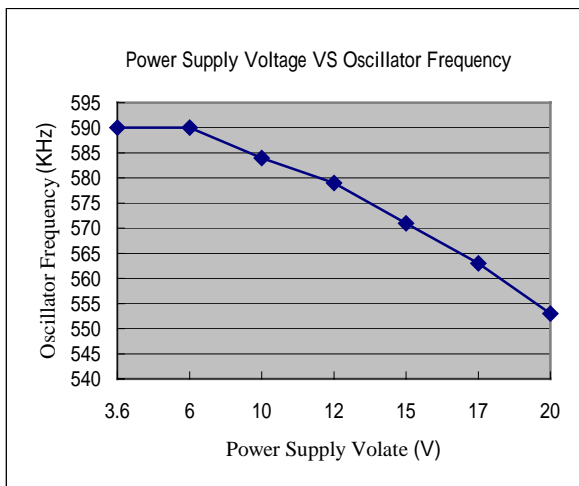

Figure 3

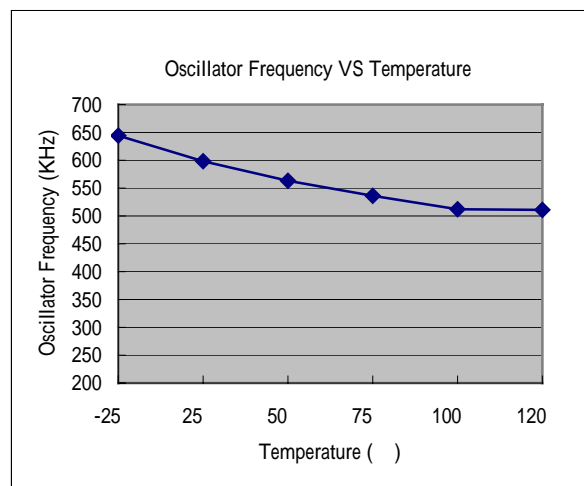

Figure 4

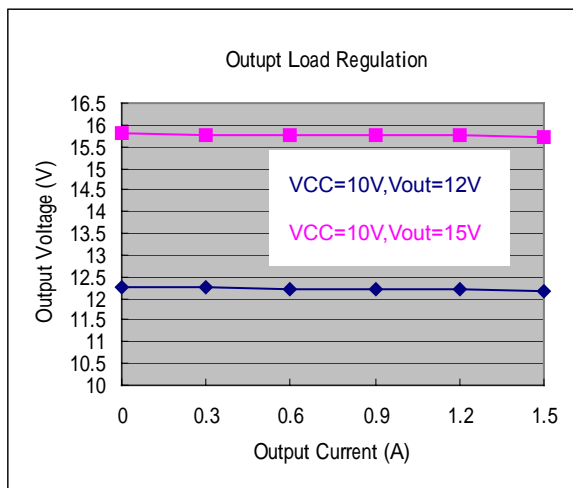

Figure 5

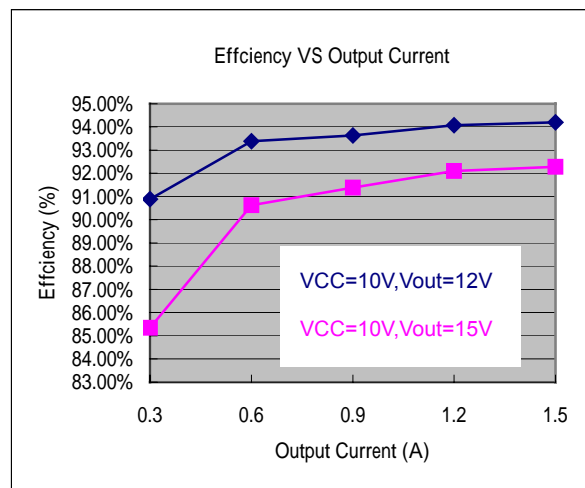
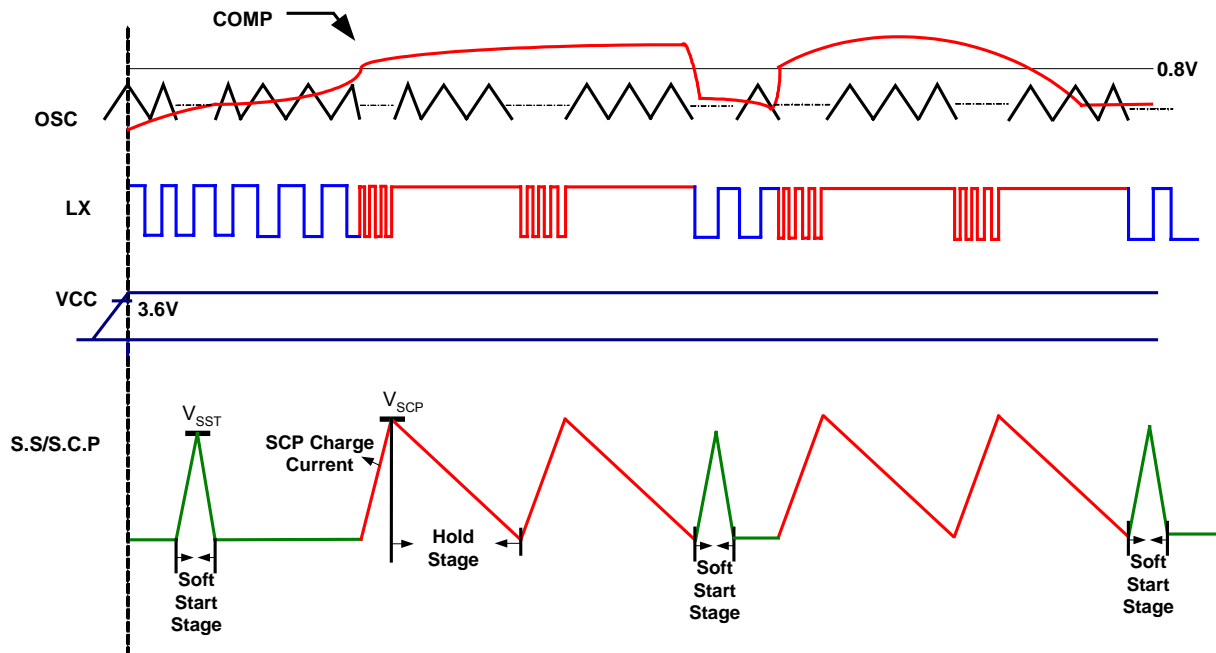

Figure 6

**TIMING WAVEFORM**



**Figure 9. PWM Timing Diagram**



## APPLICATION NOTE

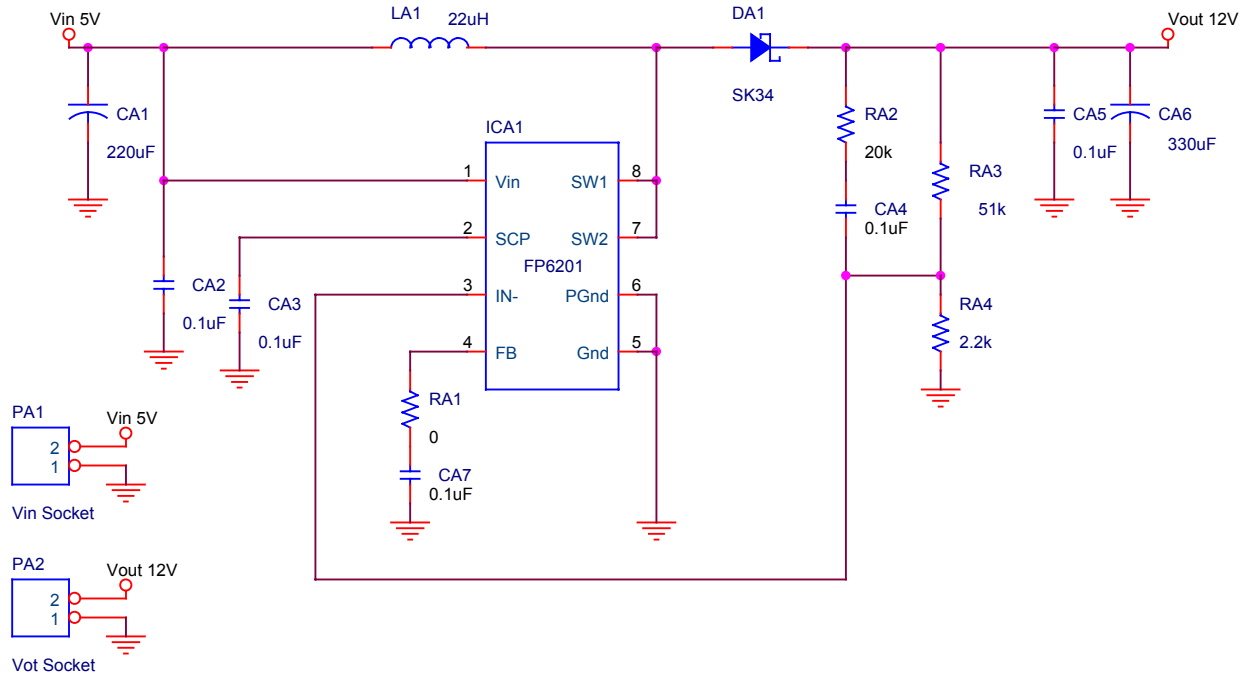

**FP6201 Basic DC-DC Regulator Circuits**

### For example:

The  $V_{IN}$  is one 5.0V power supply, and the  $V_{OUT}$  is designed for 12V / 1A solution.

The output voltage formula is:

$$V_{OUT} = \left(1 + \frac{R1}{R2}\right) * V_{IN} = \left(1 + \frac{56K\Omega}{2.43K\Omega}\right) * 0.5V = 12.02V$$

## PACKAGE OUTLINE SOP8

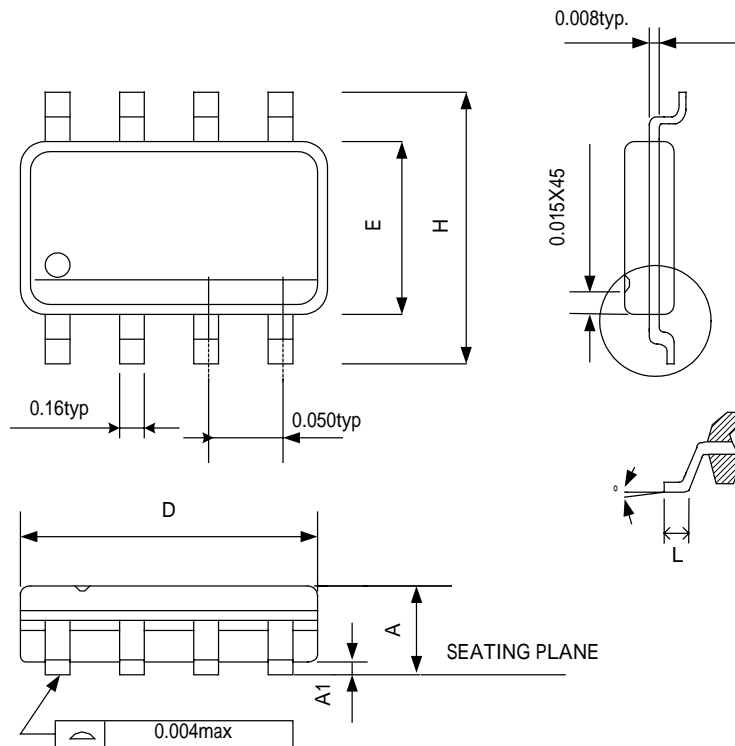

SYMBOLS	MIN	MAX
A	0.053	0.069
A1	0.004	0.010
D	0.189	0.196
E	0.150	0.157
H	0.228	0.244
L	0.016	0.050
°	0	8

UNIT:INCH

### NOTE:

1. JEDEC OUTLINE:MS-012 AA
2. DIMENSIONS "D" DOES NOT INCLUDE MOLD FLASH,PROTRUSIONS OR GATE BURRS.MOLD FLASH,PROTRUSIONS AND GATE BURRS SHALL NOT EXCEED .15mm (.06in) PER SIDE
3. DIMENSIONS "E" DOES NOT INCLUDE INTER-LEAD FLASH,OR PROTRUSIONS. INTER-LEAD FLASH AND PROTRUSIONS SHALL NOT EXCEED .25mm (.0.10in) PER SIDE.

## PACKING SPECIFICATIONS

### BOX DIMENSION

#### TUBE INSIDE BOX AND CARTON

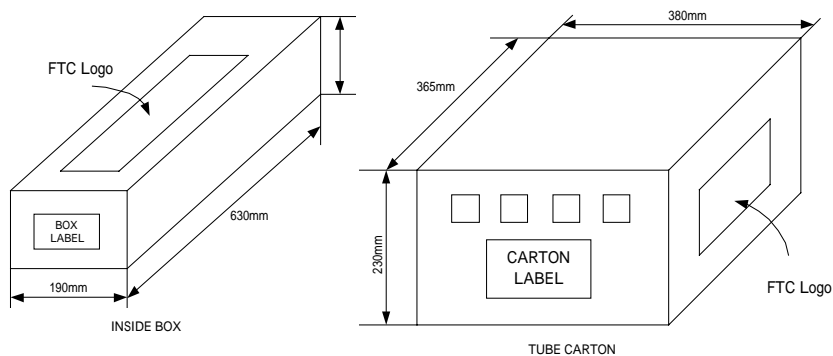

#### TAPE AND REEL INSIDE BOX AND CARTON

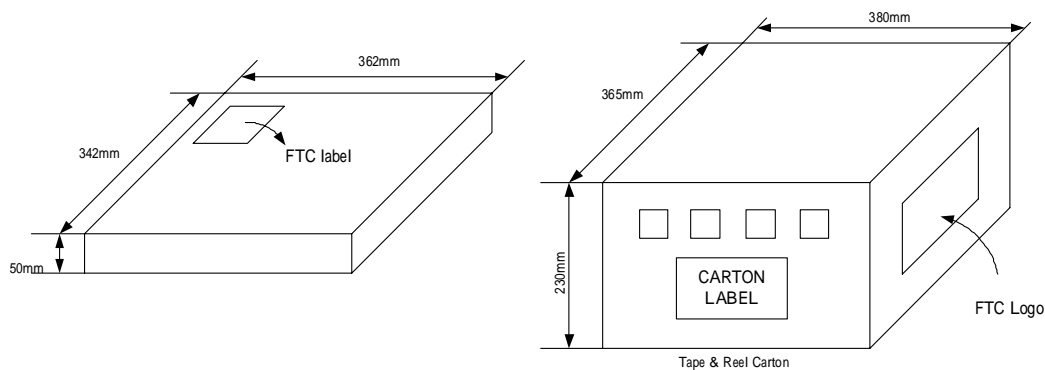

## PACKING QUANTITY SPECIFICATIONS

FP6201D-LF SOP8	FP6201DR-LF SOP8
100 EA/TUBE	2500 EA / REEL
100 TUBES / INSIDE BOX	1 REEL / INSIDE BOX
4 INSIDE BOXES / CARTON	4 INSIDE BOXES / CARTON

## LABEL SPECIFICATIONS

### Tapping & Reel

Feeling Technology Corp. Product : FP6201DR-LF Lot No : A3311C62 D/C : 6Xx-62L Q'ty : 2,500	<div style="border: 1px solid black; padding: 2px; display: inline-block;">                     無鉛                      Lead Free                 </div>
---	--

Carton

Feeling Technology Corp.	
Product Type: FP6201DR-LF	
Lot No: A3311C62	
Date Code: 6Xx-62L	
Package Type: SOP-8L	
Marking Type: Laser	無鉛 Lead Free
Total Q'ty: 10,000	

## SOP8 CARRIER TAPE DIMENSIONS

APPLICATION	W	P	E	F	D	D <sub>1</sub>
SOP8	12.0 <sup>+0.3</sup> / <sub>-0.1</sub>	8.0±0.1	1.75±0.1	5.5±0.1	1.55±0.1	1.5 <sup>+0.25</sup>

APPLICATION	P <sub>0</sub>	P <sub>1</sub>	A <sub>D</sub>	B <sub>0</sub>	K <sub>0</sub>	t
SOP8	4.0±0.1	2.0±0.1	6.4±0.1	5.20±0.1	2.1±0.10	0.30±0.013

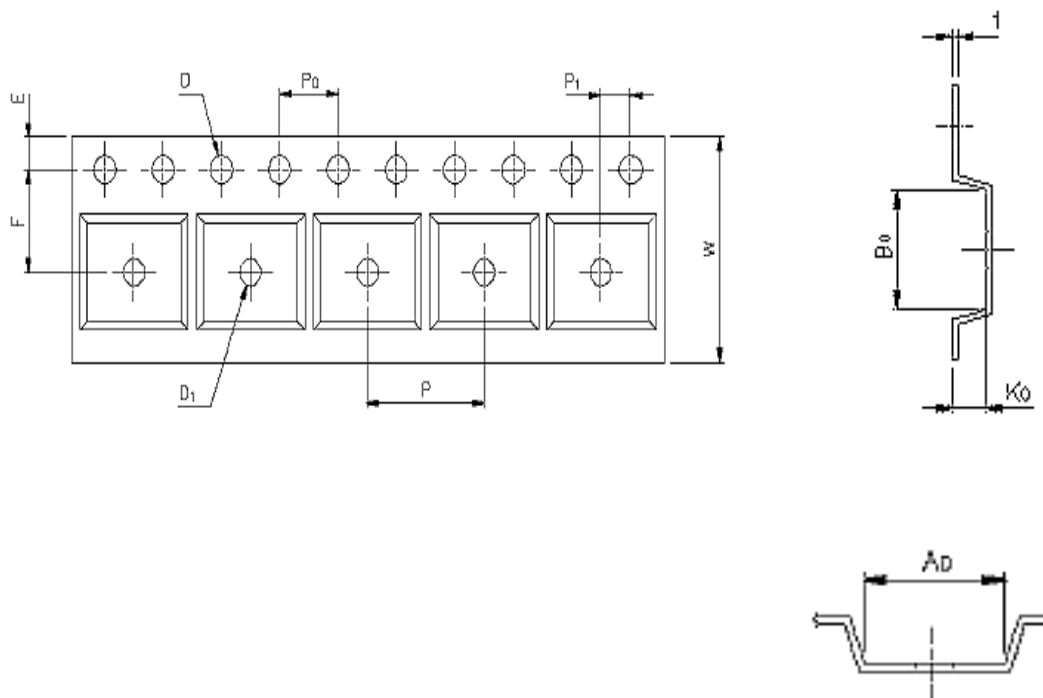

## REEL DIMENSIONS

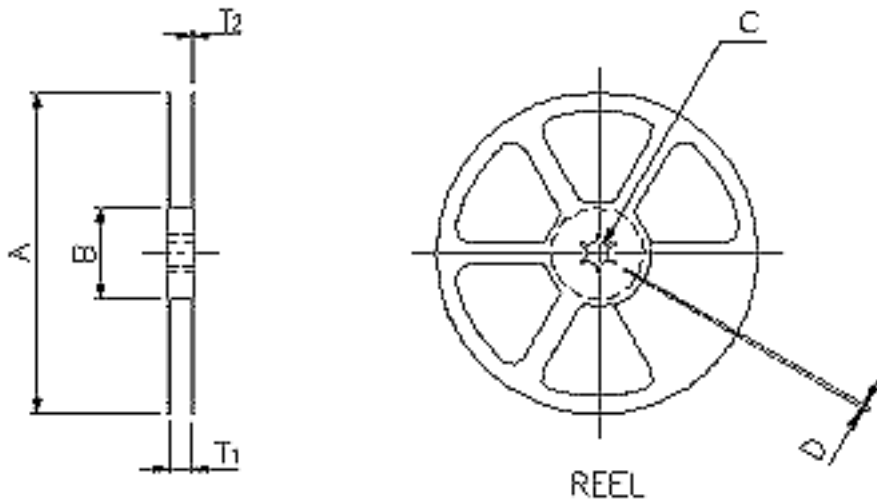

APPLICATION	MATERIAL	A	B	C	D	T <sub>1</sub>	T <sub>2</sub>
SOP8	PLASTIC REEL	330±0.1	62±1.5	12.75+0.15	2+0.6	12.4+0.2	2.0+0.2