

UL 1642

ISBN 1-55989-829-1

Lithium Batteries

Underwriters Laboratories Inc. (UL)
333 Pfingsten Road
Northbrook, IL 60062-2096

UL Standard for Safety for Lithium Batteries, UL 1642

Third Edition, Dated April 26, 1995

Revisions: This Standard contains revisions through and including June 24, 1999

Text that has been changed in any manner is marked with a vertical line in the margin. Changes in requirements are marked with a vertical line in the margin and are followed by an effective date note indicating the date of publication or the date on which the changed requirement becomes effective.

UL is in the process of converting its Standards for Safety to the Standard Generalized Markup Language (SGML), and implementing an SGML compliant document management and publishing system. SGML - an international standard (ISO 8879-1986) - is a descriptive markup language that describes a document's structure and purpose, rather than its physical appearance on a page. Significant benefits that will result from UL's use of SGML and these new systems include increased productivity, reduced turnaround times, and data and information consistency, reusability, shareability, and portability. However, the fonts, pagination, and general formatting of UL's new electronic publishing system differ from that of UL's previous publishing system. Consequently, when revision pages are issued for a Standard with the new publishing system, these differences may result in the printing of pages on which no requirements have been changed - these additional pages result from relocation of text due to repagination and reformatting of the Standard with the new publishing system.

Announcement Bulletin(s): This Standard contains the announcement bulletin(s) dated April 29, 1999. The announcement bulletin is located at the end of the Standard (after the adoption bulletin(s)).

The new and revised requirements are substantially in accordance with UL's Bulletin(s) on this subject dated January 20, 1998. The bulletin(s) is now obsolete and may be discarded.

The revisions dated June 24, 1999 include a reprinted title page (page1) for this Standard.

The master for this Standard at UL's Northbrook Office is the official document insofar as it relates to a UL service and the compliance of a product with respect to the requirements for that product and service, or if there are questions regarding the accuracy of this Standard.

UL's Standards for Safety are copyrighted by UL. Neither a printed copy of a Standard, nor the distribution diskette for a Standard-on-Diskette and the file for the Standard on the distribution diskette should be altered in any way. All of UL's Standards and all copyrights, ownerships, and rights regarding those Standards shall remain the sole and exclusive property of UL.

All rights reserved. No part of this publication may be reproduced, stored in a retrieval system, or transmitted in any form by any means, electronic, mechanical photocopying, recording, or otherwise without prior permission of UL.

Revisions of UL Standards for Safety are issued from time to time. A UL Standard for Safety is current only if it incorporates the most recently adopted revisions.

UL provides this Standard "as is" without warranty of any kind, either expressed or implied, including but not limited to, the implied warranties of merchantability or fitness for any purpose.

In no event will UL be liable for any special, incidental, consequential, indirect or similar damages, including loss of profits, lost savings, loss of data, or any other damages arising out of the use of or the inability to use this Standard, even if UL or an authorized UL representative has been advised of the possibility of such damage. In no event shall UL's liability for any damage ever exceed the price paid for this Standard, regardless of the form of the claim.

UL will attempt to answer support requests concerning WordPerfect, Envoy, and Standards-on-Diskette. However, this support service is offered on a reasonable efforts basis only, and UL may not be able to resolve every support request. UL supports a Standards-on-Diskette only if it is used under the conditions and operating systems for which it is intended. UL's support policies may change from time-to-time without notification.

UL reserves the right to change the format, presentation, file types and formats, delivery methods and formats, and the like of both its printed and electronic Standards without prior notice.

Standards-on-Diskette purchasers agree to defend, indemnify, and hold UL harmless from and against any loss, expense, liability, damage, claim, or judgement (including reasonable attorney's fees) resulting from any error or deviation introduced while purchaser is storing a Standard-on-Diskette on the purchaser's computer system.

If a single-user version Standards-on-Diskette was purchased, one copy of this Standard may be stored on the hard disk of a single personal computer, or on a single LAN file-server or the permanent storage device of a multiple-user computer in such a manner that this Standard may only be accessed by one user at a time and for which there is no possibility of multiple concurrent access. The original distribution diskette should be stored in a safe place.

If a multiple-user version Standards-on-Diskette was purchased, one copy of the Standard may be stored on a single LAN file-server, or on the permanent storage device of a multiple-user computer. The number of concurrent users shall not exceed the number of users authorized for the Standards-on-Diskette version. The original distribution diskette should be stored in a safe place.

Standards-on-Diskette are intended for on-line use, such as for viewing the requirements of a Standard, conducting a word search, and the like. Only one copy of the Standard may be printed from each single-user version of a Standards-on-Diskette. Only one copy of the Standard may be printed for each authorized user of a multiple-user version of a Standards-on-Diskette. An employee of an organization purchasing a Standard-on-Diskette can make a copy of the page or pages being viewed for their own fair and/or practical internal use. Because of differences in the computer/software/printer setup used by UL and those of Standards-on-Diskette purchasers, the printed copy obtained by a purchaser may not look exactly like the on-line screen view or the printed Standard.

The requirements in this Standard are now in effect, except for those paragraphs, sections, tables, figures, and/or other elements of the Standard having future effective dates as indicated in the note following the affected item. The prior text for requirements that have been revised and that have a future effective date are located after the Standard, and are preceded by a "SUPERSEDED REQUIREMENTS" notice.

New product submittals made prior to a specified future effective date will be judged under all of the requirements in this Standard including those requirements with a specified future effective date, unless the applicant specifically requests that the product be judged under the current requirements. However, if the applicant elects this option, it should be noted that compliance with all the requirements in this Standard will be required as a condition of continued Listing, Recognition and Follow-Up Services after the effective date, and understanding of this should be signified in writing.

This Standard consists of pages dated as shown in the following checklist:

Page	Date
1	June 24, 1999
2	April 26, 1995
2A-2B	June 24, 1999
3	April 29, 1999
4-7	April 26, 1995
8-22	June 24, 1999
23	April 26, 1995
24	April 29, 1999

No Text on This Page

APRIL 26, 1995

(Title Page Reprinted: June 24, 1999)

1

UL 1642

Standard for Lithium Batteries

First Edition – October, 1985

Second Edition – November, 1992

Third Edition

April 26, 1995

An effective date included as a note immediately following certain requirements is one established by Underwriters Laboratories Inc.

Revisions of this Standard will be made by issuing revised or additional pages bearing their date of issue. A UL Standard is current only if it incorporates the most recently adopted revisions, all of which are itemized on the transmittal notice that accompanies the latest set of revised requirements.

ISBN 1-55989-829-1

COPYRIGHT © 1985, 1999 UNDERWRITERS LABORATORIES INC.

No Text on This Page

CONTENTS

FOREWORD	4
-----------------------	---

INTRODUCTION

1 Scope	5
2 General	6
2.1 Units of measurement	6
2.2 Terminology	6
3 Glossary	6

CONSTRUCTION

4 General	7
4.1 Casing	7
4.2 Electrolyte	7
4.3 Use	7

PERFORMANCE

5 General	8
5.1 Technician-replaceable batteries	8
5.2 User-replaceable batteries	8
5.3 Multicell installations	9
6 Samples	9
7 Conditioning of Samples	12
7.1 Oven exposure	12
7.2 Temperature Cycling Test	12
7.3 Discharge	12
7.4 Charge-discharge cycling	12
8 Important Test Considerations	12
9 Temperature Measurements	13

TESTS FOR TECHNICIAN-REPLACEABLE AND USER-REPLACEABLE BATTERIES**ELECTRICAL TESTS**

10 Short-Circuit Test	13
11 Heating Test	14
11A Abnormal Charging Test	14
11B Forced-Discharge Test	14

MECHANICAL TESTS

12 Crush Test	15
13 Impact Test	15
14 Humidity Test	16
14A Shock Test	17
15 Vibration Test	17
16 Drop Test	17
17 Forced-Discharge Test	17

17.1 General	17
17.2 Method 1	17
17.3 Method 2	18
18 Abnormal Charging Test	18

ENVIRONMENTAL TESTS

18A Heating Test	18
18B Temperature Cycling Test	18
18C Low Pressure (Altitude Simulation) Test	19

TESTS FOR USER-REPLACEABLE LITHIUM BATTERIES

19 General	19
19.1 Fire-exposure test	19
19.2 Test for flaming particles	19
19.3 Projectile test	19
19.4 Explosion test	21

MARKING

20 General	23
------------------	----

No Text on This Page

FOREWORD

A. This Standard contains basic requirements for products covered by Underwriters Laboratories Inc. (UL) under its Follow-Up Service for this category within the limitations given below and in the Scope section of this Standard. These requirements are based upon sound engineering principles, research, records of tests and field experience, and an appreciation of the problems of manufacture, installation, and use derived from consultation with and information obtained from manufacturers, users, inspection authorities, and others having specialized experience. They are subject to revision as further experience and investigation may show is necessary or desirable.

B. The observance of the requirements of this Standard by a manufacturer is one of the conditions of the continued coverage of the manufacturer's product.

C. A product which complies with the text of this Standard will not necessarily be judged to comply with the Standard if, when examined and tested, it is found to have other features which impair the level of safety contemplated by these requirements.

D. A product employing materials or having forms of construction which conflict with specific requirements of the Standard cannot be judged to comply with the Standard. A product employing materials or having forms of construction not addressed by this Standard may be examined and tested according to the intent of the requirements and, if found to meet the intent of this Standard, may be judged to comply with the Standard.

E. UL, in performing its functions in accordance with its objectives, does not assume or undertake to discharge any responsibility of the manufacturer or any other party. The opinions and findings of UL represent its professional judgment given with due consideration to the necessary limitations of practical operation and state of the art at the time the Standard is processed. UL shall not be responsible to anyone for the use of or reliance upon this Standard by anyone. UL shall not incur any obligation or liability for damages, including consequential damages, arising out of or in connection with the use, interpretation of, or reliance upon this Standard.

F. Many tests required by the Standards of UL are inherently hazardous and adequate safeguards for personnel and property shall be employed in conducting such tests.

INTRODUCTION

1 Scope

1.1 These requirements cover primary (nonrechargeable) and secondary (rechargeable) lithium batteries for use as power sources in products. These batteries contain metallic lithium, or a lithium alloy, or a lithium ion, and may consist of a single electrochemical cell or two or more cells connected in series, parallel, or both, that convert chemical energy into electrical energy by an irreversible or reversible chemical reaction.

1.2 These requirements cover lithium batteries intended for use in technician-replaceable or user-replaceable applications.

1.3 These requirements are intended to reduce the risk of fire or explosion when lithium batteries are used in a product. The final acceptability of these batteries is dependent on their use in a complete product that complies with the requirements applicable to such product.

1.4 These requirements are also intended to reduce the risk of injury to persons due to fire or explosion when user-replaceable lithium batteries are removed from a product and discarded.

1.5 These requirements cover technician-replaceable lithium batteries that contain 5.0 g (0.18 ounce) or less of metallic lithium. A battery containing more than 5.0 g of lithium is judged on the basis of compliance with the requirements in this standard, insofar as they are applicable, and further examination and test to determine whether the battery is acceptable for its intended uses.

1.6 These requirements cover user-replaceable lithium batteries that contain 4.0 g (0.13 ounce) or less of metallic lithium with not more than 1.0 g (0.04 ounce) of metallic lithium in each electrochemical cell. A battery containing more than 4.0 g or a cell containing more than 1.0 g lithium may require further examination and test to determine whether the cells or batteries are acceptable for their intended uses.

1.7 These requirements do not cover the toxicity risk that may result from the ingestion of a lithium battery or its contents, nor the risk of injury to persons that may occur if a battery is cut open to provide access to the metallic lithium.

1.8 A product that contains features, characteristics, components, materials, or systems new or different from those covered by the requirements in this Standard, and that involve a risk of fire, electric shock, or injury to persons shall be evaluated using the appropriate additional component and end-product requirements as determined necessary to maintain the acceptable level of safety as originally anticipated by the intent of this standard. A product whose features, characteristics, components, materials, or systems conflict with specific requirements or provisions of this standard cannot be judged to comply with this standard. Where considered appropriate, revision of requirements shall be proposed and adopted in conformance with the methods employed for development, revision, and implementation of this standard.

2 General

2.1 Units of measurement

2.1.1 If a value for measurement is followed by a value in other units in parentheses, the second value may be only approximate. The first stated value is the requirement.

2.2 Terminology

2.2.1 The terms "lithium battery(ies)" and "battery(ies)" refer to both user-replaceable and technician-replaceable lithium batteries.

3 Glossary

3.1 For the purpose of this standard the following definitions apply.

3.2 BATTERY – (1) A single cell, or (2) a group of cells connected together either in a series or parallel configuration.

3.3 BATTERY, PRIMARY – A battery which can only be discharged once. It is not designed to be rechargeable and must be protected from a charging current.

3.4 BATTERY, SECONDARY – A battery that is intended to be discharged and recharged many times in accordance with the manufacturer's recommendations.

3.5 BATTERY, TECHNICIAN-REPLACEABLE – A battery intended for use in a product in which service and replacement of the battery will be done only by a person who has been trained to service and repair the product.

3.6 BATTERY, USER-REPLACEABLE – A battery intended for use in a product in which service and replacement of the battery may be done by the user.

3.7 CELL – A single electrochemical cell containing a positive and negative electrode.

3.8 CHARGED, FULLY – A battery is considered fully charged when the maximum amount of electrical capacity, as specified by the manufacturer, is stored in the battery.

3.9 COMPONENT, CURRENT-LIMITING – Any component employed to limit current during abnormal conditions. Current-limiting components include resistors, fuses, or thermal cutoffs.

3.10 CURRENT, ABNORMAL CHARGING – Charging current to a primary cell or battery under fault condition.

3.11 DISCHARGE, FORCED – Discharge of a battery by connection in series with an external power source so as to drive the battery into polarity reversal.

3.12 DISCHARGED, FULLY – A battery is considered fully discharged if the closed circuit voltage is less than 0.2 volts, when connected to a 100-ohm resistive load and the short-circuit current has been reduced to less than 1 milliamperere.

3.13 DISCHARGED, HALF – A battery is considered half discharged when half of the battery's rated electrical capacity has been drained from it.

3.14 EXPLOSION – When the cell or battery contents are forcibly expelled and the cell or battery casing is torn or split into two or more pieces.

3.15 MATERIAL, TOXIC – Any material having a toxic hazard rating of 2, moderate, in the Sax Dangerous Properties of Industrial Materials reference book or related reference guide.

3.16 ROOM TEMPERATURE – Approximately 23°C (73°F).

3.17 VENTING – When the battery or cell electrolyte is emitted as a liquid, droplets, or vapor from a designed vent or through a seal.

CONSTRUCTION

4 General

4.1 Casing

4.1.1 The casing of a lithium battery shall have the strength and rigidity necessary to resist the abuses to which it may be subjected, without resulting in a risk of fire. The casing of a user-replaceable lithium battery shall have the strength and rigidity necessary to resist the abuses to which it may be subjected without resulting in a risk of injury to persons.

4.1.2 A cell of a user-replaceable battery shall be in a rigid casing of sufficient strength to prevent flexing. A tool providing the mechanical advantage of a pliers, screwdriver, or hacksaw shall be the minimum capable of opening the user-replaceable cell casing, if opening of the casing will expose metallic lithium.

Exception: This requirement does not apply to a cell containing less than 0.02 g (0.0007 ounce) of lithium metal.

4.2 Electrolyte

4.2.1 A user-replaceable battery shall not contain pressurized vapor or liquid that could spray toxic materials into the eyes or leak more than 5 milliliters of toxic liquid when the battery casing is punctured under normal laboratory conditions, 23 ±2°C (73 ±4°F).

4.3 Use

4.3.1 A lithium battery shall be protected from abnormal charging currents during use. A battery tested and found acceptable for the charging current, I_C (see 18.1), under fault conditions specified by the manufacturer, shall be protected from larger charging currents in the end product application by:

- a) Two blocking components, such as diodes, or
- b) One blocking component and one current limiting component, such as a resistor or a fuse.

The current limiting component shall limit the charging current to one-third the value used in the Abnormal Charging Test, Section 18.

Exception No. 1: Charge protection in the battery circuit is not required in end product applications where a battery cannot be subjected to a charging current, such as a battery operated device.

Exception No. 2: Protection components are not required for specific applications where a battery has been tested and found not to have a risk of explosion.

Exception No. 3: A rechargeable battery requires only a current limiting component, not a blocking component.

PERFORMANCE

5 General

5.1 Technician-replaceable batteries

5.1.1 Technician-replaceable lithium cells or batteries are to be tested as described in Sections 10 – 19. Section 11B, Forced Discharge Test, is applicable only to cells intended to be used in multicell applications such as battery packs. For multicell installations, also see 5.3.1. No fire or explosion shall occur as a result of the Short-Circuit Test, Section 10, the Shock Test, Section 14A, the Vibration Test, Section 15, the Temperature Cycling Test, Section 18B or the Altitude Simulation Test, Section 18C. Also, the temperature of an exterior cell or battery casing shall not exceed 150°C (302°F) when tested in accordance with the Short-Circuit Test. When a fire or explosion occurs as a result of the Abnormal Charging Test, Section 11A; Crush Test, Section 12; Impact Test, Section 13; or Heating Test, Section 18A; the use of the technician replaceable cell or battery shall be restricted to applications in which it is not exposed to, or is protected from, any conditions shown to cause a fire or explosion. Cells and batteries subjected to the Shock Test, Section 14A, Vibration Test, Section 15, Temperature Cycling Test, Section 18B, and Altitude Simulation Test, Section 18C shall also not leak or vent. For these tests, unacceptable leakage is determined to have occurred when the resulting mass loss exceeds the values shown in Table 5.1, Venting and Leakage Mass Loss Criteria.

5.1.1 revised June 24, 1999

Table 5.1
Venting and leakage mass loss criteria

Table 5.1 added June 24, 1999

Mass of Cell or Battery	Maximum Mass % Loss
Not more than 1 gram	0.5
More than 1.0 gram and not more than 5.0 gram	0.2
More than 5.0 gram	0.1

5.2 User-replaceable batteries

5.2.1 User-replaceable lithium cells or batteries are to be tested as described in Sections 10 – 19. Section 11B, Forced Discharge Test, is applicable only to cells intended to be used in multicell applications such as battery packs. In addition to complying with the requirements for a technician replaceable cell or battery as specified in 5.1.1, a user-replaceable cell or battery shall not explode or ignite when subjected to the Crush Test, Section 12, or the Impact Test, Section 13.

5.2.1 revised June 24, 1999

5.2.2 Sets of five specimens each are to be used for the Test for Flaming Particles, Section 19.2; and the Projectile Test, Section 19.3; see Table 6.3. When only one specimen from a set of five does not comply with the requirements, another set of five specimens is to be tested. All specimens from this second set shall comply with the requirements.

5.2.2 revised June 24, 1999

5.3 Multicell installations

5.3.1 A technician-replaceable or user-replaceable cell intended for use in multicell installations or battery packs shall also be tested as described in 10.3 and Section 11B. No fire or explosion shall occur as a result of these tests. In addition, batteries subjected to the test described in 10.3 shall meet the requirements as described in 5.1.1 and 5.2.1 for a cell or battery subjected to the Short-Circuit Test, Section 10.

5.3.1 revised June 24, 1999

Figure 5.1 **Tests for technician-replaceable batteries**

Figure 5.1 deleted June 24, 1999

Figure 5.2 **Tests for user-replaceable batteries**

Figure 5.2 deleted June 24, 1999

6 Samples

6.1 Fresh primary cells or batteries and primary cells or batteries that have been conditioned by partial or complete discharge, or both, are to be used for the tests described in Sections 10 – 19. The number of samples to be used in each test for a primary technician-replaceable cell or battery is shown in Table 6.1. The number of samples to be used in each test for a primary user-replaceable cell or battery is shown in Table 6.3. When a group of cells or batteries of different sizes, but similar chemistries is involved, selected sizes representative of the range are to be tested.

6.1 revised June 24, 1999

6.2 Fresh secondary cells or batteries and secondary cells or batteries that have been conditioned by charge-discharge cycling are to be used for the tests described in Sections 10 – 19. The number of samples to be used in each test for a secondary technician-replaceable cell or battery is shown in Table 6.2. The number of samples to be used in each test for a secondary user-replaceable cell or battery is shown in Table 6.4. When a group of cells or batteries of different sizes, and similar chemistries is involved, selected sizes representative of the range are to be tested.

6.2 revised June 24, 1999

Table 6.1
Number of batteries to be used in each test for primary technician-replaceable batteries

Table 6.1 revised June 24, 1999

Test	Conditioning of batteries		
	Fresh	One half ^a discharged	Complete discharged
Electrical Tests			
Short-Circuit ^b at room temp.	5	5	—
at 60°C (140°F)	5	5	—
Abnormal Charge	5	5	5
Discharge ^c	5	5	5
Mechanical Tests			
Crush	5	5	—
Impact	5	5	—
Shock	5	5	5
Vibration	5	5	5
Environmental Tests			
Heating	5	5	—
Temperature Cycling	5	5	5
Altitude Simulation	5	5	5
^a Only cells with a liquid cathode, such as thionyl chloride or sulfur dioxide, are conditioned by one-half discharge. ^b For series or parallel use, see 10.3. ^c For series use, see 11B.2.			

Table 6.2
Number of batteries to be used in each test for secondary technician-replaceable batteries

Table 6.2 revised June 24, 1999

Test	Fresh	Charge/discharge cycled
Electrical Tests		
Short-Circuit ^{a, c} at room temp.	5	5
at 60°C (140°F)	5	5
Abnormal Charge	5	5
Discharge ^b	5	5
Mechanical Tests		
Crush ^c	5	5
Impact ^c	5	5
Shock	5	5
Vibration	5	5
Environmental Tests		
Heating	5	5
Temperature Cycling	5	5
Altitude Simulation	5	5
^a For series or parallel use, see 10.3. ^b For series use, see 11B.2. ^c Tests are to be conducted on samples in the fully charged condition.		

Table 6.3
Number of batteries to be used in each test for primary user-replaceable batteries

Table 6.3 revised June 24, 1999

Test	Conditioning of batteries		
	Fresh	One half ^a discharged	Complete discharged
Electrical Tests			
Short-Circuit ^b at room temp.	5	5	—
at 60°C (140°F)	5	5	—
Abnormal Charge	5	5	5
Discharge ^c	5	5	5
Mechanical Tests			
Crush	5	5	—
Impact	5	5	—
Shock	5	5	5
Vibration	5	5	5
Environmental Tests			
Heating	5	5	—
Temperature Cycling	5	5	5
Altitude Simulation	5	5	5
User Replaceable Lithium Battery Tests			
Flaming Particles	5	—	—
Projectile	5	—	—

^aOnly cells with a liquid cathode, such as thionyl chloride or sulfur dioxide, are conditioned by one-half discharge.
^bFor series or parallel use, see 10.3.
^cFor series use, see 11B.2.

Table 6.4
Number of batteries to be used in each test for secondary user-replaceable batteries

Table 6.4 revised June 24, 1999

Test	Fresh	Batteries conditioned by charge-discharge cycling
Electrical Tests		
Short-Circuit ^{a, c} at room temp.	5	5
at 60°C (140°F)	5	5
Abnormal Charge	5	5
Discharge ^b	5	5
Mechanical Tests		
Crush ^{a, c}	5	5
Impact ^c	5	5
Shock	5	5
Vibration	5	5
Environmental Tests		
Heating	5	5
Temperature Cycling	5	5
Altitude Simulation	5	5
User Replaceable Lithium Battery Tests		
Flaming Particles	5	—

Table 6.4 Continued on Next Page

Table 6.4 Continued

Test	Fresh	Batteries conditioned by charge-discharge cycling
Projectile	5	–
^a For series or parallel use, see 10.3. ^b For series use, see 11B.2. ^c Tests are to be conducted on samples in the fully charged condition.		

7 Conditioning of Samples

7.1 Oven exposure

7.1 deleted June 24, 1999

7.1.1 Deleted June 24, 1999.

7.2 Temperature Cycling Test

7.2 revised and relocated as 18B June 24, 1999

7.2.1 Deleted June 24, 1999.

7.3 Discharge

7.3.1 Primary batteries are to be completely discharged by connecting their terminals through resistors that provide the desired level of discharge within 60 days. Completely discharged is considered to be the state in which the closed-circuit voltage has been reduced to less than 0.2 volts and the short-circuit current to less than 1.0 milliamperes. Batteries are to be discharged at room temperature. Cells with a liquid cathode such as thionyl chloride or sulfur dioxide, shall also be conditioned by one-half discharge.

7.3.1 revised June 24, 1999

7.3.2 For solid electrolyte and other types of primary lithium batteries that cannot be discharged within 60 days because of the small currents they inherently produce, longer discharge times plus discharge at higher temperatures may be used to obtain the desired level of discharge. The manufacturer's recommended discharge procedures are to be followed so as to obtain the required discharge level in the minimum time.

7.4 Charge-discharge cycling

7.4.1 Secondary cells are to be conditioned at 25°C (77°F). Cells are continuously cycled as per the manufacturer's specifications. The specification shall be such that the full rated capacity of the cell is utilized and the number of cycles accumulated shall be at least equal to 25% of the advertised cycle life of the cell or cycled continuously for 90 days, whichever is shorter. Cycling is to be done either individually or in groups. Cells are to be recharged prior to testing as indicated in Table 6.2 and Table 6.4.

7.4.1 revised June 24, 1999

8 Important Test Considerations

8.1 Some lithium batteries are capable of exploding when the tests described in Sections 10 – 19 are conducted. It is important that personnel be protected from the flying fragments, explosive force, sudden release of heat, and noise that results from such explosions. The test area is to be well ventilated to protect personnel from possible harmful fumes or gases.

8.1 revised June 24, 1999

8.2 As an additional precaution, the temperatures on the surface of the battery casings shall be monitored during the tests described in Sections 10, 13 and 17. All personnel involved in the testing of lithium batteries are to be instructed never to approach a lithium battery while the surface temperature exceeds 90°C (194°F).

8.2 revised June 24, 1999

8.3 For protection, the Test for Flaming Particles, 19.2, and the Projectile Test, 19.3 are to be conducted in a room separate from the observer.

8.3 added June 24, 1999

9 Temperature Measurements

9.1 Temperatures are to be measured by thermocouples consisting of wires not larger than No. 24 AWG (0.21 mm²) and not smaller than No. 30 AWG (0.05 mm²) and a potentiometer-type instrument.

9.2 The temperature measurements on the batteries are to be made with the measuring junction of the thermocouple held tightly against the metal casing of the battery.

TESTS FOR TECHNICIAN-REPLACEABLE AND USER-REPLACEABLE BATTERIES

ELECTRICAL TESTS

10 Short-Circuit Test

10.1 Each test sample battery, in turn, is to be short-circuited by connecting the positive and negative terminals of the battery with copper wire having a maximum resistance load of 0.1 ohm. The battery is to discharge until a fire or explosion is obtained, or until it is completely discharged and the battery case temperature has returned to near ambient temperature.

10.1 revised June 24, 1999

10.2 Tests are to be conducted at room temperature and at 60 ± 2°C (140 ± 4°F). The batteries are to reach equilibrium at room temperature or 60 ± 2°C, as applicable, before the terminals are connected.

10.2 revised June 24, 1999

10.3 A battery is to be tested individually unless the manufacturer indicates that it is intended for use in series or parallel. For series or parallel use, additional tests on five sets of batteries are to be conducted using the maximum number of batteries to be covered for each configuration.

10.4 When an overcurrent or thermal protective device that has been investigated for the purpose actuates during the test, the test shall be repeated with the battery supply connected to the maximum load that does not cause the protective device to open. A protective device that has not been investigated for the purpose shall be short-circuited.

10.4 added June 24, 1999

10.5 The samples shall not explode or catch fire. The temperature of the exterior cell or battery casing shall not exceed 150°C (302°F).

10.5 added June 24, 1999

11 Heating Test

Section 11 relocated as Section 18A June 24, 1999

11A Abnormal Charging Test

11A added June 24, 1999

11A.1 Cells or batteries discharged to the manufacturer's rated capacity shall be used for this test.

11A.1 added June 24, 1999

11A.2 Each test sample battery is to be subjected to a charging current of three times the current I_c , specified by the manufacturer by connecting it in opposition to a dc-power supply. The specified charging current is to be obtained by connecting a resistor of the specified size and rating in series with the battery. The test time is to be calculated using the formula:

$$t_c = \frac{2.5 C}{3(I_c)}$$

In which:

t_c is the charging time in hours,

C is the capacity of the battery in ampere-hours, and

I_c is the charging current, in amperes, specified by the manufacturer.

The minimum test time shall be 48 hours. This does not require that the initial I_c be maintained for 48 hours.

18.1 revised and relocated as 11A.2 June 24, 1999

11A.3 When a overcurrent or thermal protective device that has been investigated for the purpose actuates during the test, the test shall be repeated with the battery supply connected to the maximum load that does not cause the protective device to open. A protective device that has not been investigated for the purpose shall be short-circuited.

11A.3 added June 24, 1999

11A.4 The samples shall not explode or catch fire.

11A.4 added June 24, 1999

11B Forced-Discharge Test

Section 17 relocated as Section 11B June 24, 1999

11B.1 This test is intended for cells that are to be used in multicell applications, such as battery packs.

11B.1 added June 24, 1999

11B.2 A completely discharged cell is to be force-discharged by connecting it in series with fresh cells of the same kind. The number of fresh cells to be connected in series with the discharged cell is to equal the maximum number less one of the cells to be covered for series use. Five cells are to be completely discharged, at room temperature.

17.3.1 revised and relocated as 11B.2 June 24, 1999

11B.3 Once the completely discharged cell is connected in series with the specified number of fresh cells the resultant battery pack is to be short circuited.

11B.3 added June 24, 1999

11B.4 The positive and negative terminals of the sample are to be connected with a copper wire with a maximum resistance load of 0.1 ohm. The battery is to discharge until a fire or explosion is obtained, or until it is completely discharged and the battery case temperature has returned to near ambient temperature.

11B.4 added June 24, 1999

11B.5 When an overcurrent or thermal protective device that has been investigated for the purpose actuates during the test, the test shall be repeated with the battery supply connected to the maximum load that does not cause the protective device to open. A protective device that has not been investigated for the purpose shall be short-circuited.

11B.5 added June 24, 1999

11B.6 The samples shall not explode or catch fire.

11B.6 added June 24, 1999

MECHANICAL TESTS

12 Crush Test

12.1 A battery is to be crushed between two flat surfaces. The force for the crushing is to be applied by a hydraulic ram with a 1.25 inch (32 mm) diameter piston. The crushing is to be continued until a pressure reading of 2500 psig (17.2 MPa) is reached on the hydraulic ram, applied force of 3000 pounds (13 kN). Once the maximum pressure has been obtained it is to be released.

12.1 revised June 24, 1999

12.2 A cylindrical or prismatic battery is to be crushed with its longitudinal axis parallel to the flat surfaces of the crushing apparatus. A prismatic battery is also to be rotated 90 degrees around its longitudinal axis so that both the wide and narrow sides will be subjected to the crushing force. Each sample battery is to be subjected to a crushing force in only one direction. Separate samples are to be used for each test.

12.3 A coin or button battery is to be crushed with the flat surface of the battery parallel with the flat surfaces of the crushing apparatus.

12.4 The samples shall not explode or catch fire.

12.4 added June 24, 1999

13 Impact Test

13.1 A test sample battery is to be placed on a flat surface. A 5/8 inch (15.8 mm) diameter bar is to be placed across the center of the sample. A 20 pound (9.1 kg) weight is to be dropped from a height of 24 ± 1 inch (610 ± 25 mm) onto the sample. (See Figure 13.1).

13.1 revised June 24, 1999

Figure 13.1 Impact test

Figure 13.1 added June 24, 1999

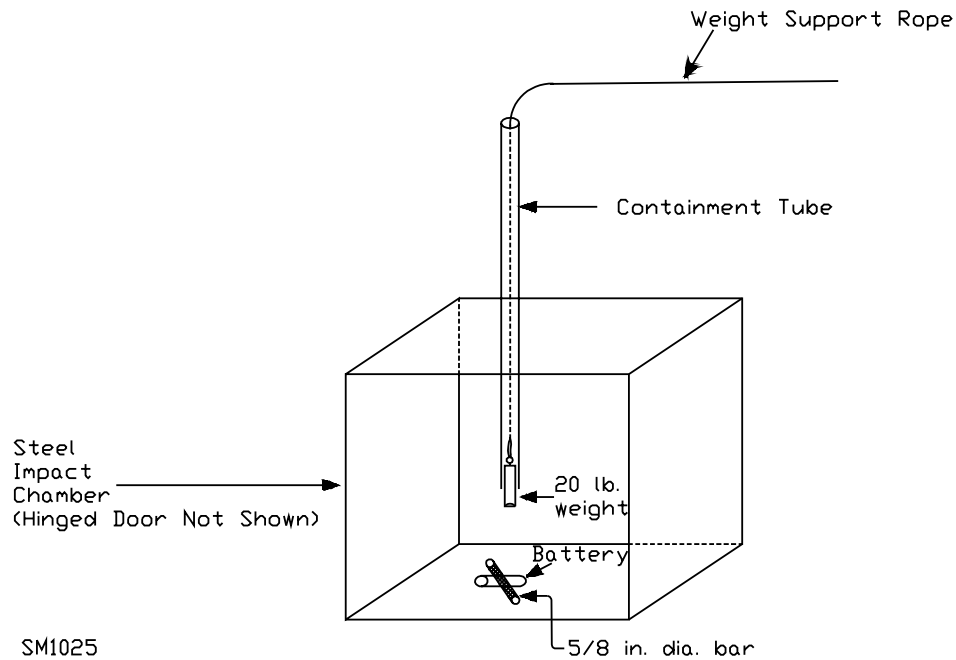

13.2 A cylindrical or prismatic battery is to be impacted with its longitudinal axis parallel to the flat surface and perpendicular to the longitudinal axis of the 5/8 inch (15.8 mm) diameter curved surface lying across the center of the test sample. A prismatic battery is also to be rotated 90 degrees around its longitudinal axis so that both the wide and narrow sides are subjected to the impact. Each sample battery is to be subjected to only a single impact. Separate samples are to be used for each test.

13.2 revised June 24, 1999

13.3 A coin or button battery is to be impacted with the flat surface of the test sample parallel to the flat surface and the 5/8 inch (15.8 mm) diameter curved surface lying across its center.

13.3 revised June 24, 1999

13.4 The samples shall not explode or catch fire.

13.4 added June 24, 1999

14 Humidity Test

14 deleted June 24, 1999

14.1 Deleted June 24, 1999.

14.2 Deleted June 24, 1999.

14A Shock Test

Added 14A effective June 26, 2000

14A.1 The cell is to be secured to the testing machine by means of a rigid mount which supports all mounting surfaces of the cell. Each cell shall be subjected to a total of three shocks of equal magnitude. The shocks are to be applied in each of three mutually perpendicular directions unless it has only two axes of symmetry in which case only two directions shall be tested. Each shock is to be applied in a direction normal to the face of the cell. For each shock the cell is to be accelerated in such a manner that during the initial 3 milliseconds the minimum average acceleration is 75 g (where g is the local acceleration due to gravity). The peak acceleration shall be between 125 and 175 g. Cells shall be tested at a temperature of $20 \pm 5^{\circ}\text{C}$ ($68 \pm 9^{\circ}\text{F}$).

Added 14A.1 effective June 26, 2000

14A.2 The samples shall not explode or catch fire. In addition, the sample shall not vent or leak as described in 5.1.1.

Added 14A.2 effective June 26, 2000

15 Vibration Test

15.1 A battery is to be subjected to simple harmonic motion with an amplitude of 0.03 inch (0.8 mm) [0.06 inch (1.6 mm) total maximum excursion].

15.2 The frequency is to be varied at the rate of 1 hertz per minute between 10 and 55 hertz, and return in not less than 90 nor more than 100 minutes. The battery is to be tested in three mutually perpendicular directions. For a battery that has only two axes of symmetry, the battery is to be tested perpendicular to each axis.

15.3 The samples shall not explode or catch fire. In addition the sample shall not vent or leak as described in 5.1.1.

15.3 added June 24, 1999

16 Drop Test

16 deleted June 24, 1999

16.1 Deleted June 24, 1999.

17 Forced-Discharge Test

Section 17 relocated as Section 11B June 24, 1999

17.1 General

17.1 deleted June 24, 1999

17.1.1 Deleted June 24, 1999.

17.2 Method 1

17.2 deleted June 24, 1999

17.2.1 Deleted June 24, 1999.

17.3 Method 2

17.3 deleted June 24, 1999

17.3.1 Revised and relocated as 11B.2 June 24, 1999.

18 Abnormal Charging Test

Section 18 relocated as Section 11A June 24, 1999

18.1 Revised and relocated as 11A.2 June 24, 1999.

18.2 Deleted June 24, 1999.

ENVIRONMENTAL TESTS

18A Heating Test

Section 11 relocated as Section 18A June 24, 1999

18A.1 A battery is to be heated in a gravity convection or circulating air oven. The temperature of the oven is to be raised at a rate of $5 \pm 2^\circ\text{C}$ ($9 \pm 3.6^\circ\text{F}$) per minute to a temperature of $150 \pm 2^\circ\text{C}$ ($302 \pm 3.6^\circ\text{F}$) and remain for 10 minutes at that temperature before the test is discontinued.

11.1 revised and relocated as 18A.1 June 24, 1999

18A.2 The samples shall not explode or catch fire.

18A.2 added June 24, 1999

18B Temperature Cycling Test

7.2 revised and relocated as 18B June 24, 1999

18B.1 The batteries are to be placed in a test chamber and subjected to the following cycles:

- a) Raising the chamber-temperature to $70 \pm 3^\circ\text{C}$ ($158 \pm 5^\circ\text{F}$) within 30 minutes and maintaining this temperature for 4 hours.
- b) Reducing the chamber temperature to $20 \pm 3^\circ\text{C}$ ($68 \pm 5^\circ\text{F}$) within 30 minutes and maintaining this temperature for 2 hours.
- c) Reducing the chamber temperature to minus $40 \pm 3^\circ\text{C}$ (minus $40 \pm 5^\circ\text{F}$) within 30 minutes and maintaining this temperature for 4 hours.
- d) Raising the chamber temperature to $20 \pm 3^\circ\text{C}$ ($68 \pm 5^\circ\text{F}$) within 30 minutes.
- e) Repeating the sequence for a further 9 cycles.
- f) After the 10th cycle, storing the batteries for 7 days prior to examination.

Added 18B.1 effective June 26, 2000

18B.2 The samples shall not explode or catch fire. In addition, the samples shall not vent or leak as described in 5.1.1.

Added 18B.2 effective June 26, 2000

18C Low Pressure (Altitude Simulation) Test

Added 18C effective June 26, 2000

18C.1 Sample batteries are to be stored for 6 hours at an absolute pressure of 11.6 kPa (1.68 psi) and a temperature of $20 \pm 3^\circ\text{C}$ ($68 \pm 5^\circ\text{F}$).

Added 18C.1 effective June 26, 2000

18C.2 The samples shall not explode or catch fire as a result of the Altitude Simulation Test. In addition, the samples shall not vent or leak as described in 5.1.1.

Added 18C.2 effective June 26, 2000

TESTS FOR USER-REPLACEABLE LITHIUM BATTERIES

19 General

19.1 Fire-exposure test

19.1 deleted June 24, 1999

19.1.1 Deleted June 24, 1999.

19.1.2 Deleted June 24, 1999.

19.2 Test for flaming particles

19.2.1 A cheesecloth panel shall not ignite when a cell or battery is subjected to the test described in 19.2.2.

19.2.1 revised June 24, 1999

19.2.2 Each test sample cell or battery is to be placed on a steel wire mesh screen having 20 openings per inch (25.4 mm) and a wire diameter of 0.017 inch (0.43 mm). The screen is to be mounted 1-1/2 inches (38.1 mm) above a burner. The fuel and air flow rates are to be set to provide a bright blue flame that causes the wire screen to glow a bright red. A panel of cheesecloth layers is to be positioned vertically 3 feet (0.91 m), from the center of the wire screen. See Figures 19.1A and 19.2A. The panel of cheesecloth is to be 1 yard square (914 mm by 914 mm) and is to consist of four layers of cheesecloth material weighing 0.4 – 0.6 ounces per square yard ($12 - 18 \text{ g/m}^2$). The test sample is to be positioned so that sparks or flaming particles are ejected toward the center of the cheesecloth panel. In some cases, it shall be required to wire the test sample to the screen to hold it in place. The burner is then to be ignited and the battery is to be observed until it explodes, or until it is destroyed.

19.2.2 revised June 24, 1999

Figure 19.1

Test apparatus for projectile test

Figure 19.1 relocated as Figure 19.3 June 24, 1999

19.3 Projectile test

19.3.1 When subjected to the test described in 19.3.2 no part of an exploding cell or battery shall penetrate the wire screen such that some or all of the cell or battery protrudes through the screen.

19.3.1 revised June 24, 1999

Figure 19.1A
Test apparatus for flaming particle test

Figure 19.1A added June 24, 1999

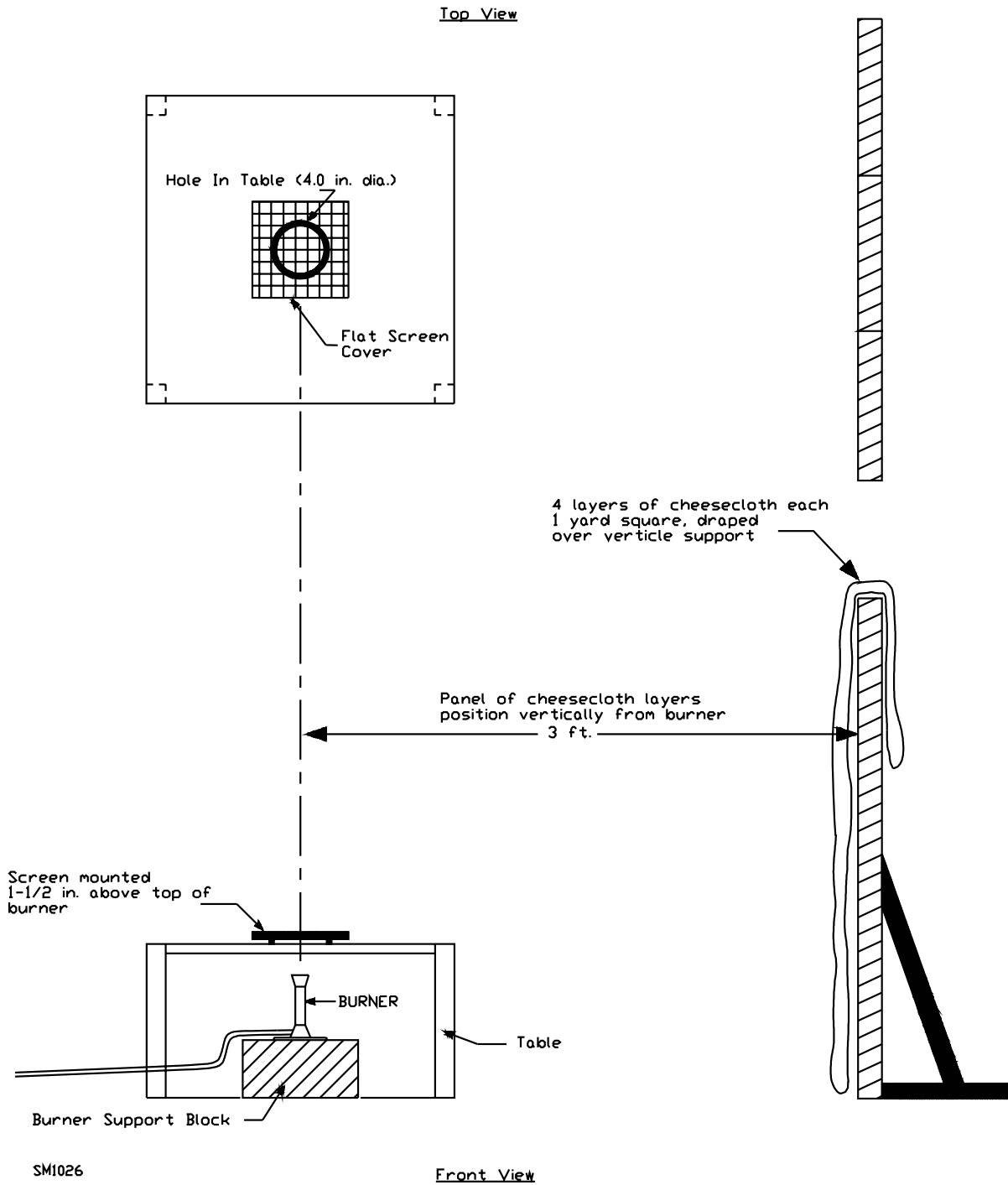
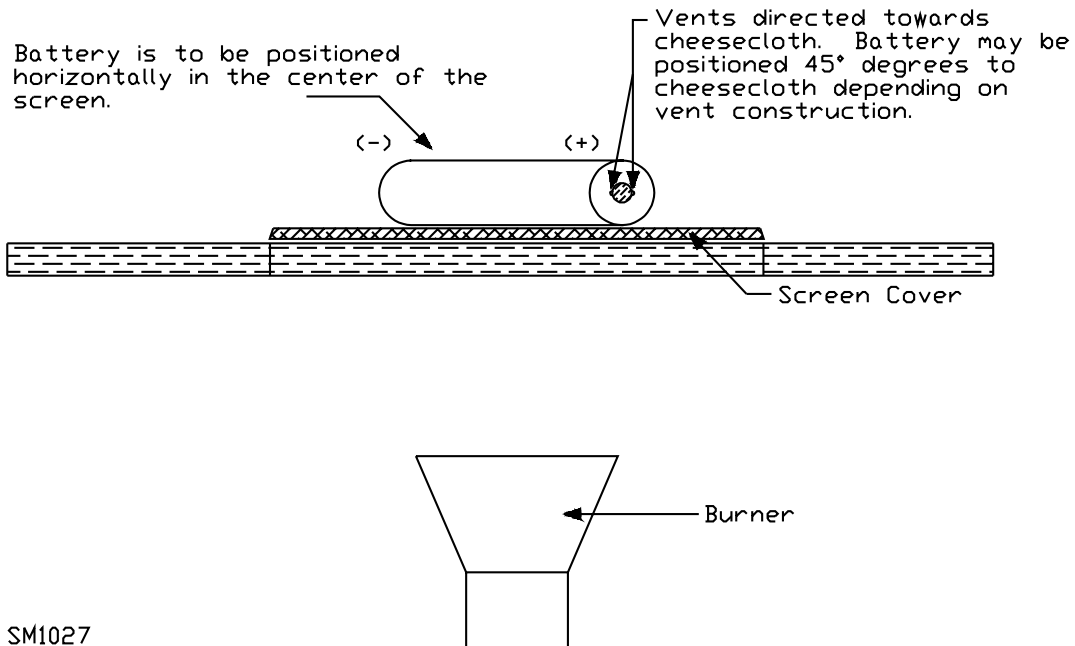

Figure 19.2A
Battery orientation

Figure 19.2A added June 24, 1999



19.3.2 Each test sample cell or battery is to be placed on a platform table having a 4-inch (102-mm) diameter hole in the center covered by a screen. The screen is to be of steel wire mesh having 20 openings per inch (25.4 mm) and a wire diameter of 0.017 inch (0.43 mm). An eight-sided covered wire cage, 2 feet (610 mm) across and 1 foot (305 mm) high, made from metal screening is to be placed over the test sample. See Figure 19.3. The metal screening is to be constructed from 0.010-inch (0.25-mm) diameter metal wire with 16 – 18 wires per inch in each direction. The sample is to be placed on the screen covering the hole in the center of the table and is to be heated, until it explodes, or until it is destroyed.

19.3.2 revised June 24, 1999

19.4 Explosion test

19.4 deleted June 24, 1999

19.4.1 Deleted June 24, 1999.

19.4.2 Deleted June 24, 1999.

19.4.3 Deleted June 24, 1999.

Figure 19.2
Explosion test chamber

Figure 19.2 deleted June 24, 1999

Figure 19.3 Test apparatus for projectile test

Figure 19.1 relocated as Figure 19.3 June 24, 1999

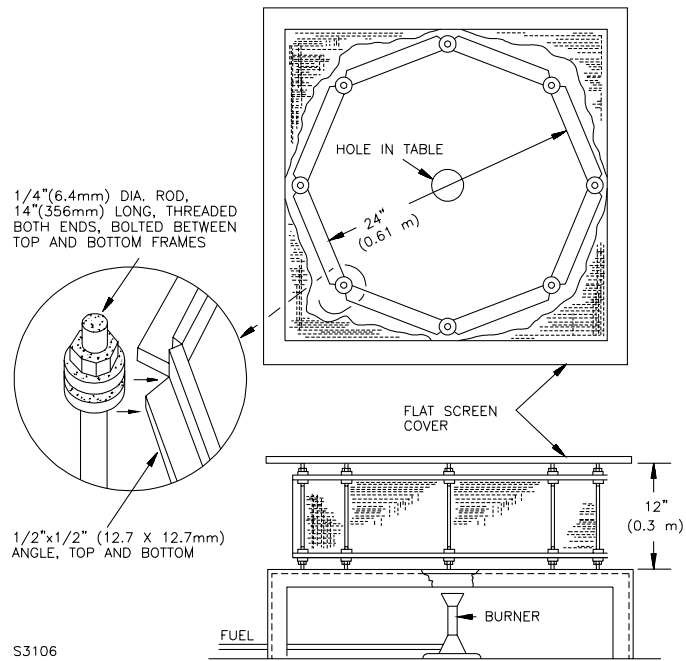

MARKING

20 General

20.1 A battery shall be marked with the manufacturer's name, trade name, or trademark and model designation.

20.2 A battery shall be marked with the word "WARNING" and the following or an equivalent statement: "Risk of fire, explosion, and burns. Do not recharge, disassemble, crush, heat above 212°F, or incinerate."

Exception No. 1: A cylindrical battery that is smaller in capacity than 300 milliampere hours and a coin, button, or pin battery is not required to be marked if the tests indicate these risks are not obtained.

Exception No. 2: A battery found not to present a risk under one or more of the conditions specified in Sections 8 – 19 need not be marked for those conditions.

Exception No. 3: A battery that is between 300 – 950 milliampere hours in capacity may be marked with the word "WARNING" and an abbreviated statement similar to the following: "Risk of explosion. Do not recharge, open, or incinerate." If space does not permit marking on the battery, this marking may be on the smallest unit package.

Exception No. 4: A user-replaceable battery may be marked with the word "CAUTION" in place of "WARNING."

20.3 The packaging for a user-replaceable battery shall be marked with the word "CAUTION" and the following or equivalent statements:

"Risk of fire and burns. Do not recharge, disassemble, heat above 212°F, or incinerate. Keep battery out of reach of children and in original package until ready to use. Dispose of used batteries promptly. Never put batteries in mouth. If swallowed, contact your physician or local poison control center."

Exception No. 1: The last two sentences are applicable only for a cell or battery that is less than 1.25 inch (32 mm) diameter by 0.15 inch (3.8 mm) thick.

Exception No. 2: Packaging for a battery found not to present a risk under one or more of the conditions specified in Sections 8 – 19 need not be marked for those conditions.

20.4 The end product with a user-replaceable lithium battery shall be permanently marked adjacent to the battery:

"Replace battery with (battery manufacturers name or end product manufacturer's name, part number) only. Use of another battery may present a risk of fire or explosion. See owners manual for instructions."

Exception: If it is not feasible to include these instructions on the end product, the information may be included in the operating or maintenance instructions providing the battery or battery compartment is marked with the following:

"See operating or maintenance instructions for type of battery to be used."

20.5 The operating or maintenance instructions shall provide the user with complete instructions as to how to replace and dispose of a used battery. This information shall include the following:

a) A warning notice stating the following or the equivalent:

"CAUTION - The battery used in this device may present a risk of fire or chemical burn if mistreated. Do not recharge, disassemble, heat above 100°C (212°F), or incinerate. Replace battery with (battery manufacturers name or end product manufacturer's name and part number) only. Use of another battery may present a risk of fire or explosion.

b) Complete instructions as to how to replace the battery ending with the statement:

"Dispose of used battery promptly. Keep away from children. Do not disassemble and do not dispose of in fire "

20.6 If a manufacturer produces a battery at more than one factory, each battery package shall have a distinctive marking to identify it as the product of a particular factory.

Added 20.6 effective April 26, 1996

Subjects 1642, 2054

333 Pfingsten Road
Northbrook, IL 60062
April 29, 1999

**TO: Industry Representatives on the Industry Advisory Conference of UL for Lithium Batteries
Casualty Council of Underwriters Laboratories Inc.
Electrical Council of Underwriters Laboratories Inc.
Fire Council of Underwriters Laboratories Inc.
Subscribers to UL's Standards Service for Lithium Batteries
Subscribers to UL's Standards Service for Household Commercial Batteries
Subscribers to UL's Listing Service for Household Commercial Batteries
Subscribers to UL's Recognition Service for Sealed Nickel Batteries, and Lithium Batteries**

SUBJECT: Performance Testing of Batteries

UL announces a program to include additional performance testing as part of the Listing and Recognition programs for Household and Commercial, Sealed Nickel, and Lithium Batteries. The performance testing will include determination of battery capacity at various temperatures, capacity retention following long term storage, cycle life, and determination of internal resistance. This testing can be conducted in accordance with the proposed ANSI and IEC standards for portable primary and rechargeable batteries and can be done during a submittal for battery Listing or Recognition or conducted independently.

UL will also participate with industry in any future development of ANSI or IEC performance test procedures and requirements.

This bulletin should be kept with your copy of the standard.

Questions regarding interpretation of requirements should be directed to the responsible UL Staff. Please see Appendix A of this bulletin regarding designated responsibility for the subject product categories. Please contact Joseph Allen or John Hawley for information regarding battery performance testing.

UNDERWRITERS LABORATORIES INC.

JEFF PRUSKO (Ext. 43416)
Project Engineer
Standards Department

REVIEWED BY:

JOSEPH P. ALLEN (Ext. 43103)
Engineering Group Leader
Engineering Services 3016ENBK

REVIEWED BY:

JOHN HAWLEY (Ext. 42077)
Managing Engineer
Engineering Services 3016XNBK

AM

1642ann.sgm

APPENDIX A

DESIGNATED RESPONSIBILITY FOR UL PRODUCT CATEGORIES

BBCV2, LITHIUM BATTERIES – COMPONENT
 BBET2, NICKEL, SEALED BATTERIES – COMPONENT
 BBFS, HOUSEHOLD AND COMMERCIAL BATTERIES

The individuals shown in the following tables are involved with the investigation of products covered under the subject categories. The Primary Designated Engineer (shown in UPPERCASE letters) coordinates the establishment and uniform interpretation of UL requirements applicable to the product categories. The Designated Engineers (shown in lowercase letters) work with the Primary Designated Engineer to interpret requirements and maintain standards.

Should you have questions regarding the interpretation of the requirements proposed in this bulletin or any adopted requirements that affect your product, you are encouraged to contact the individual at the office to which you normally submit your products.

The Industry Advisory Conference (IAC) Chairman for the subject categories is John Hawley at UL's Northbrook office. The IAC Chairman oversees the significant interpretations made by the Primary Designated Engineer and arbitrates any differences regarding interpretation of UL requirements.

CCN	Office/Subsidiary	Responsible Engineer	Extension
BBCV2	Northbrook	JOSEPH ALLEN	43103
	RTP	Stephen Derynck	11663
	Santa Clara	Andrea Cote	32940

CCN	Office/Subsidiary	Responsible Engineer	Extension
BBET2	Camas	Daniel Deatherage	55682
	Northbrook	JOSEPH ALLEN	43103
	Santa Clara	Andrea Cote	32940

CCN	Office/Subsidiary	Responsible Engineer	Extension
BBFS	Northbrook	JOSEPH ALLEN	43103
	Taiwan	Cannon Sun	70323

No Text on This Page