

70:小戴

产品型号 MODEL	BCK-2052WH	客户名称 CUSTOMER		版本 REVISION	1.1
产品说明 DESCRIPTION	开关电源变压器 SWITCHING POWER TRANSFORMER	客户料号 CUS P/N		日期 DATE	2007/06/23

规格变更履历表

版本	变更理由及内容	发行日期	发行部门
1.0	新订	2007/05/22	工程部
1.1	增加产品底部点胶, 外围包两层绝缘胶带	2007/06/23	工程部

拟制 PREPARED BY	审核 CHECKED BY	批准 APPROVED BY	页码 PAGE
廖海	胡	P	第 1 页 共 4 页

产品型号 MODEL	BCK-2052WH	客户名称 CUSTOMER	版本 REVISION	1.1
产品说明 DESCRIPTION	开关电源变压器 SWITCHING POWER TRANSFORMER	客户料号 CUS P/N	日期 DATE	2007/06/23

1. 机械尺寸 (PHYSICAL DIMENSION) : mm

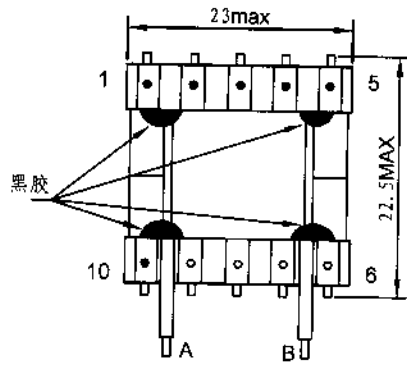

BOTTOM VIEW

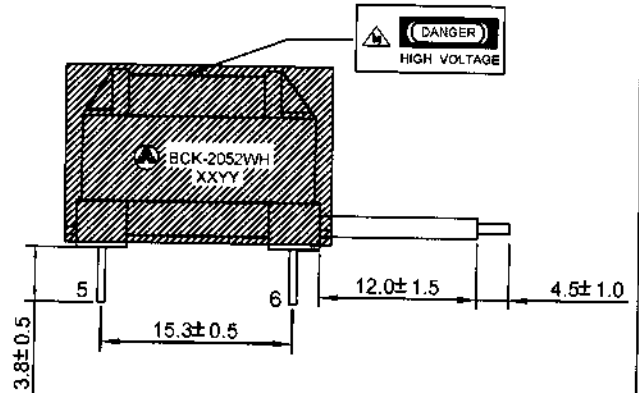

SIDE VIEW

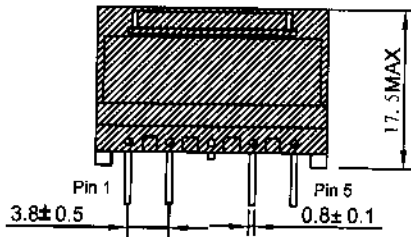

ELEVATION

注:

1. PIN6,7,8,9 拔掉.
2. PIN3 剪去2/3
3. 产品外围包两层0.05*15mm的绝缘胶带
4. 产品底部须点黑胶固定(如图所示)
5. 产品顶部贴高压标签, 高压标签上不可有三强标志, 只允许有高压标识

2. 电气原理图 (SCHEMATIC)

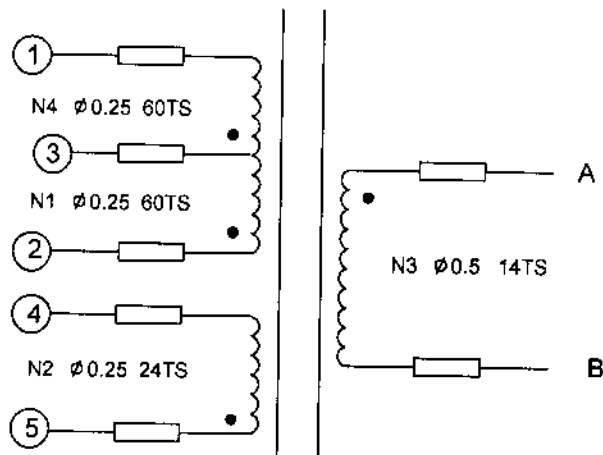

拟制 PREPARED BY	审核 CHECKED BY	批准 APPROVED BY	页码 PAGE
			第2页 共4页

产品型号 MODEL	BCK-2052WH	客户名称 CUSTOMER		版本 REVISION	1.1
产品说明 DESCRIPTION	开关电源变压器 SWITCHING POWER TRANSFORMER	客户料号 CUS P/N		日期 DATE	2007/06/23

3. 结构图: SECTIONAL VIEW

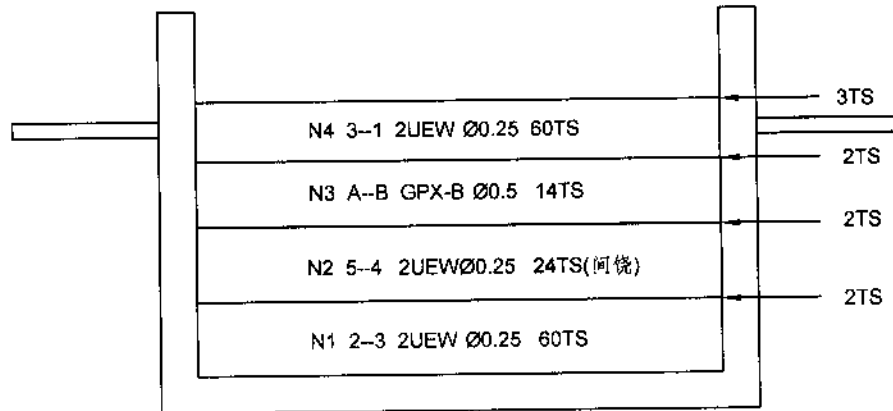

4. 电参数: ELECTRICAL CHARACTERISTICS

4-1 电感: INDUCTANCE (AT F=1KHz 0.3Vrms 25 ± 5°C)
L2-1=2.2mH ± 8%

4-2 漏感: LEAKAGE INDUCTANCE (AT F=1KHz 0.3Vrms 25 ± 5°C)
L2-1=120uHMAX (SHORTED PIN4.5.A. B)

4-3 直流电阻: DC RESISTANCE (AT 25 ± 5°C)
R2-1=2.0Ω MAX

4-4 抗电强度: DIELECTRIC STRENGTH
AC3.75KV 50Hz 5mA,1min. Between Pri to Sec,
AC1.5KV 50Hz 5mA,1min. Between Pri to Core
AC1.5KV 50Hz 5mA,1min. Between Sec to Core

4-5 绝缘电阻: INSULATION RESISTANCE
THE INSULATION RESISTANCE BETWEEN WINDINGS AND WINDINGS TO CORE IS
MORE THAN 100MΩ AT DC500V.

拟制 PREPARED BY	审核 CHECKED BY	批准 APPROVED BY	页码 PAGE
任海	胡		第 3 页 共 4 页



产品型号 MODEL	BCK-2052WH	客户名称 CUSTOMER		版本 REVISION	1.1
产品说明 DESCRIPTION	开关电源变压器 SWITCHING POWER TRANSFORMER	客户料号 CUS P/N		日期 DATE	2007/06/23

5. 材料表: MATERIAL LIST

ITEM	DESCRIPTION	TRADE NAME	MANUFACTURE	UL FILE NO
1	FERRITE CORE	JR2KBF2	WUXI SPINEL MAGNETIC CO., LTD	
2	BOBBIN	T375J PHENOLIC	CHANG CHUN PLASTICS CO LTD	E59481(S)
3	WIRE	UEW-B	TAI-I COPPER(GUANZHOU) CO., LTD	E85640
		GPX-B	SHANGHAI XINYIELECTRONICS CIRCUIT EQUIPMENTS CO.,LTD	E243712
4	INSULATING TAPE	PZ	JINGJIANG YAHUA PRESSURE SENSITIVE GLUE CO LTD	E165111
5	VARNISH	8562/C	HANG CHEUNG PETROCHEMICAL LTD	E200154
6	INSULATING TUBE	CB-TT	CHUANGYUAN ELECTRONICS (SHENZHEN) CO.,LTD	E180908
7	EPOXY	ONE COMPONENT BLACK	WINKING INDUSTRIAL CO.LTD	

6. 可靠性: RELIABILITY

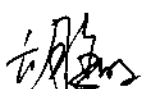
据国标SJ2916-88标准,本产品的使用环境条件为:
 温度: TEMPERATUER RANGER -10°C--+55° C;
 相对湿度: RELATIVE HUMIDITY 40° C时不大于90%;
 气压: PNEUMATIC 86----106KPa.

拟 制 PREPARED BY	审 核 CHECKED BY	批 准 APPROVED BY	页 码 PAGE
			第 4 页 共 4 页