

General Description

The TD1507 is a easy to use adjustable step-down (buck) switch-mode voltage regulators. The device is available in an adjustable output version. It is capable of driving a 2.5A load with excellent line and load regulation.

Requiring a minimum number of external components, the regulator is simple to use and include internal frequency compensation, and a fixed-frequency oscillator.

The output voltage is guaranteed to $\pm 3\%$ tolerance under specified input voltage and output load conditions. The oscillator frequency is guaranteed to $\pm 15\%$. External shutdown is included, featuring typically 80 μA standby current. Self protection features include a two stage frequency reducing current limit for the output switch and an over temperature shutdown for complete protection under fault conditions.

The TD1507 is available in TO252-5L package.

Features

- Adjustable output version
- Output adjustable from 1.23v to 34V
- Fixed 150KHz frequency internal oscillator
- Guaranteed 2.5A output load current
- Input voltage range up to 36V
- Low power standby mode, I_Q typically 70 μA
- TTL shutdown capability
- Excellent line and load regulation
- High efficiency
- Thermal shutdown and current limit protection
- Available in TO252-5L package

Applications

- Simple High-efficiency step-down regulator
- On-card switching regulators
- Positive to negative converter
- LCD monitor and LCD TV
- DVD recorder and PDP TV
- Battery charger
- Step-down to 3.3V for microprocessors

Package Types



Figure 1. Package Types of TD1507

Pin Assignments

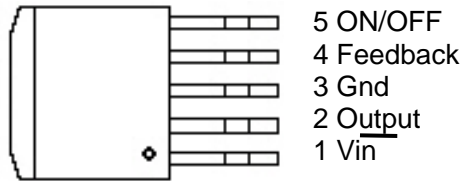

TO252-5L

Pin Descriptions

Name	Description
Vin	Input supply voltage
Output	Switching output
Gnd	Ground
Feedback	Output voltage feedback
ON/OFF	ON/OFF shutdown Active is "Low" or floating

Ordering Information

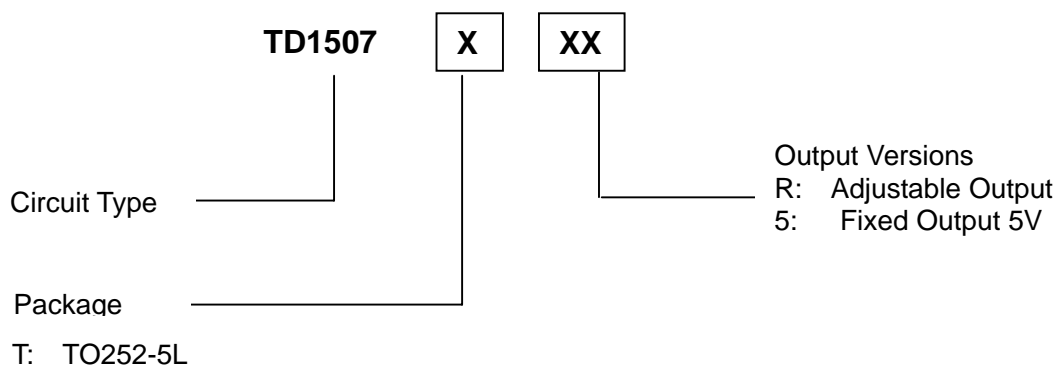

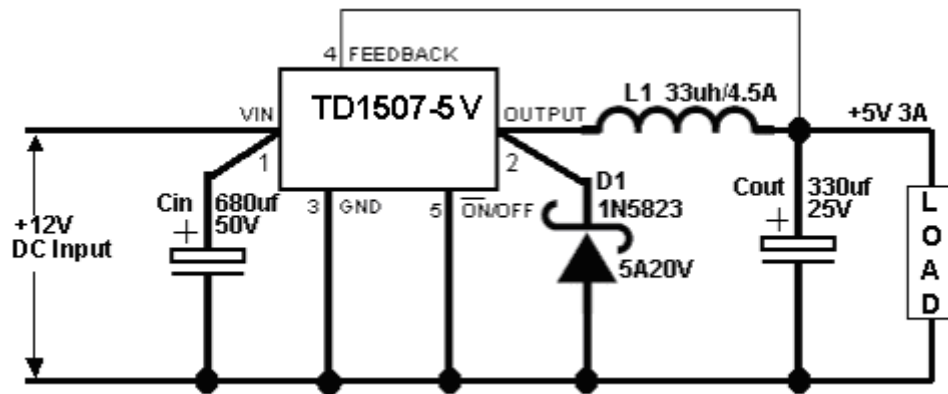

Figure 3. Typical Application of TD1507

Absolute Maximum Ratings

Note1: Stresses greater than those listed under Maximum Ratings may cause permanent damage to the device. This is a stress rating only and functional operation of the device at these or any other conditions above those indicated in the operation is not implied. Exposure to absolute maximum rating conditions for extended periods may affect reliability.

Parameter	Value	Unit
Supply Voltage V_{in}	-0.3 to 40	V
Feedback VFB pin voltage	-0.3 to $V_{in}+0.3$	V
ON/OFF Pin voltage	-0.3 to $V_{in}+0.3$	V
Output pin voltage	-0.3 to $V_{in}+0.3$	V
Output Voltage to Ground (Steady State)	-1	V
Power Dissipation	Internally limited	W
Operating Temperature Range	-40 to +125	°C
Storage Temperature	-65 to +150	°C
Lead Temperature (Soldering, 10 sec)	200	°C
ESD(HM)	2000	V

Electrical Characteristics

Unless otherwise specified, $V_{in} = 12V$. $I_{load} = 0.5A$, $T_a = 25^{\circ}C$.

Symbol	Parameter	Conditions	Min.	Typ.	Max.	Unit
I_b	Feedback bias current	$V_{FB}=1.3V$		10	50/100	nA
I_Q	Quiescent current	$V_{FB}=12V$ force driver off		5	10	mA
I_{STBY}	Standby quiescent current	ON/OFF=5V, $V_{IN}=36V$		70	150	uA
F_{OSC}	Oscillator frequency		127	150	173	KHz
V_{SAT}	Saturation voltage	$I_{OUT}=2A$		1.10	1.4/1.5	V
I_{CL}	Current Limit	Peak Current ($V_{FB}=0V$)		4.5	5.5/6.5	A
I_L	Output leakage current	Output=0V ($V_{FB}=12V$)			50	uA
	Output leakage current	Output=-1V ($V_{IN}=36V$)		2	30	mA
V_{IL} V_{IH}	ON/OFF pin logic input Threshold voltage	Low (Regulator ON)		1.3	0.6	V
		High (Regulator OFF)	2.0	1.3		V
I_H	ON/OFF pin input current	$V_{LOGIC}=2.5V$ (Regulator OFF)		5	15	uA

2.5A 150KHZ PWM Buck DC/DC Converter

TD1507

I_L		$V_{LOGIC}=0.5V(\text{Regulator ON})$		0.02	5	μA
θ_{JC}	Thermal Resistance Junction to Case	TO252-5L		10		$^{\circ}C/W$
θ_{JA}	Thermal Resistance Junction to Ambient (Note1)	TO252-5L		50		$^{\circ}C/W$
TD1507 ADJ	Vfb: Output Voltage	$11V \leq V_{IN} \leq 36V, 0.2A \leq I_{LOAD} \leq 3A, V_{OUT}$ for 9V	1.193/ 1.180	1.23	1.267/ 1.280	V
	η : Efficiency	$V_{IN}=12V, V_{OUT}=9V, I_{LOAD}=3A$		88		%
TD1507 5V	Vout: Output Voltage	$7V \leq V_{IN} \leq 36V, 0.2A \leq I_{LOAD} \leq 3A$	4.800/4 .750	5.0	5.200/ 5.250	V
	η : Efficiency	$V_{IN}=12V, I_{LOAD}=3A$		85		%

Specifications with **boldface type** are for full operating temperature range, the other type are for $T_J=25^{\circ}C$.

Note1: Thermal resistance with copper area of approximately 3 in².

Typical Performance Characteristics

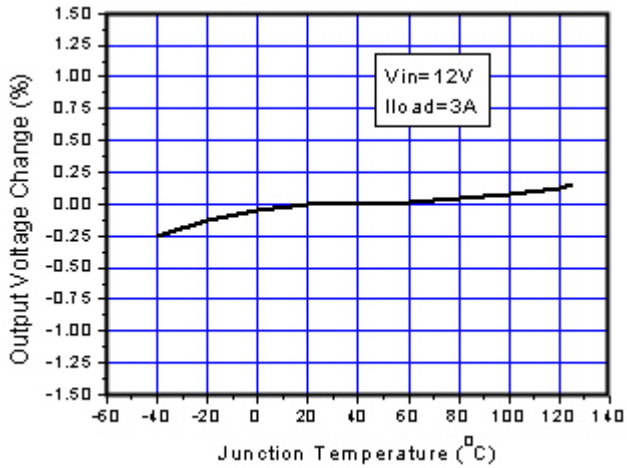

Figure 4. Output Voltage vs. Temperature

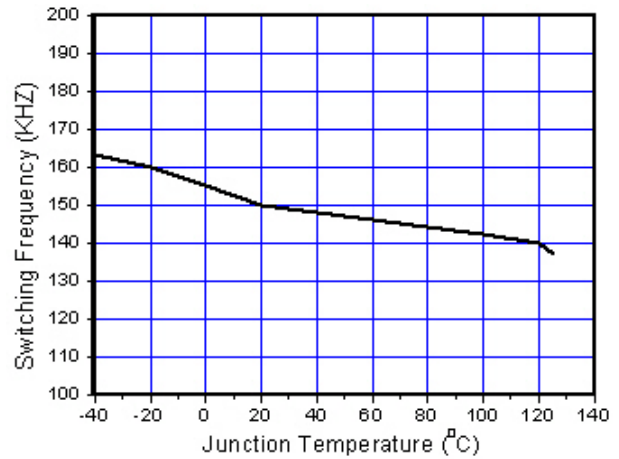

Figure 5. Switching Frequency vs. Temperature

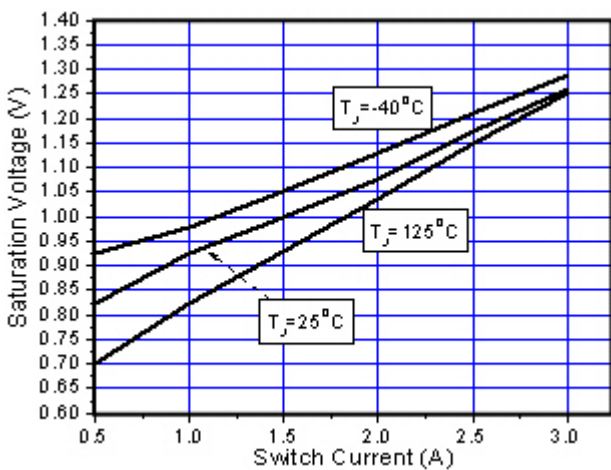

Figure 6. Output Saturation Characteristics

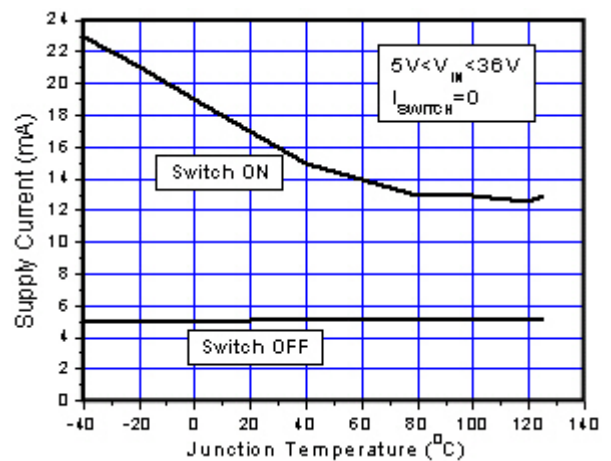

Figure 7. Quiescent Current vs. Temperature

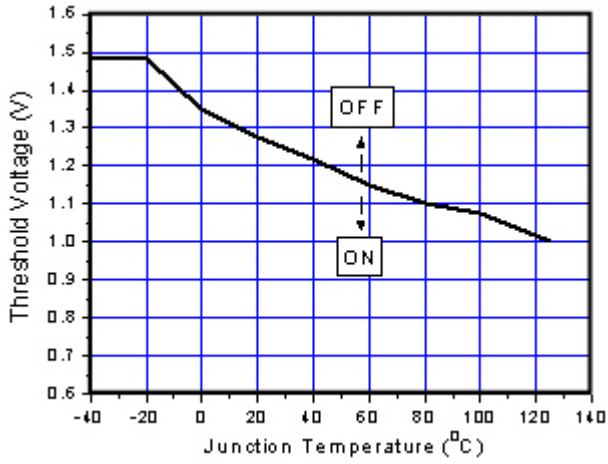

Figure 8. ON/OFF Pin Voltage

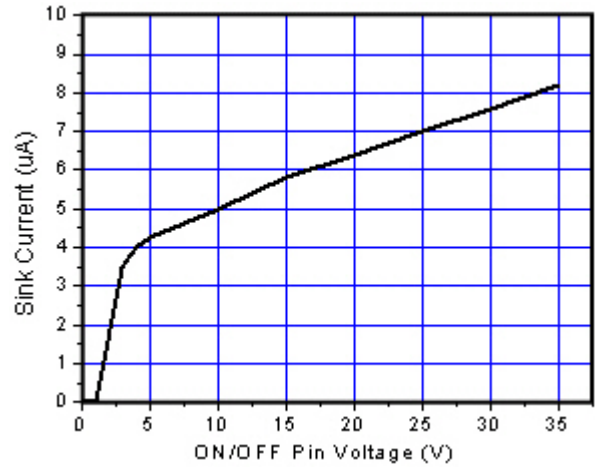

Figure 9. ON/OFF Pin Sink Current

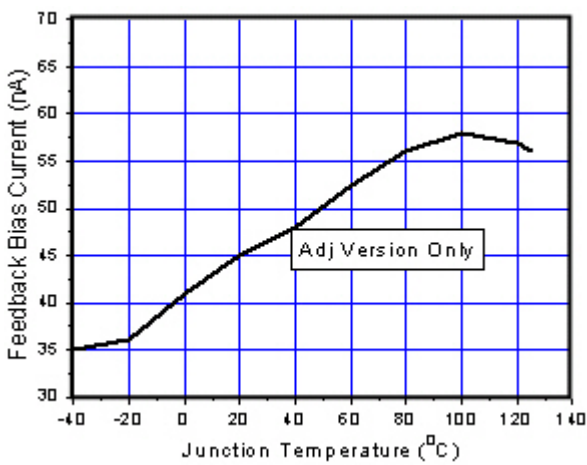
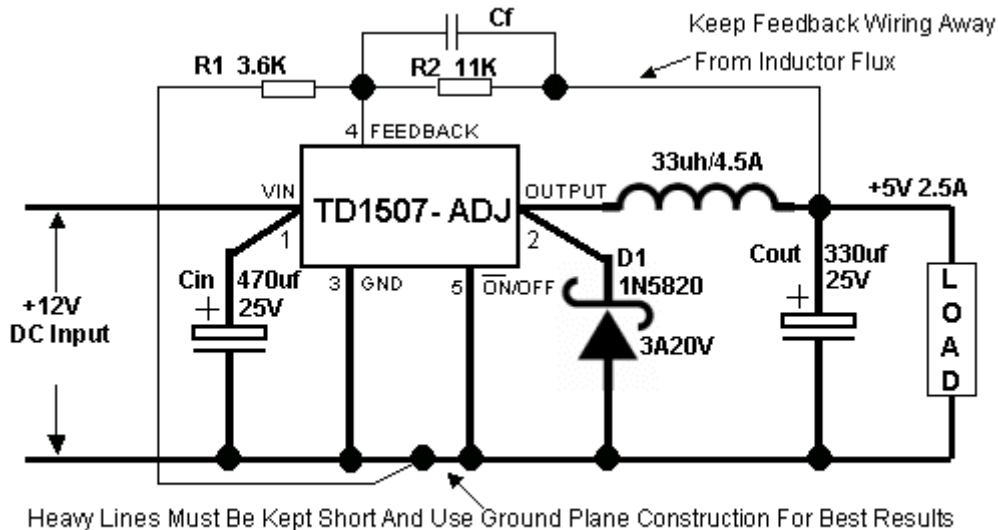

Figure 10. Output Saturation Characteristics

Typical Application Circuit



$V_{out} = V_{ref}(1+R2/R1)$ (Where $V_{ref}=1.23V$; $C_f=10nf$)

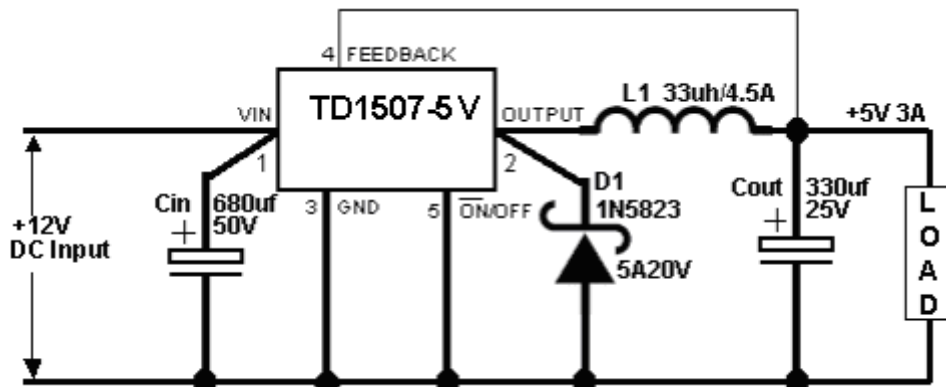

Figure 11. Typical Application of TD1507

Vout	R1	R2	Cf (Operational)
3.3V	1.6K	2.7K	33nf
5V	3.6K	11K	10nf
9V	6.8K	43K	1.5nf
12V	1.5K	13K	1nf

Table 1. Vout VS. R1, R2, Cf Select Table

Output Voltage	Input Voltage	Inductor (L1)	Output Capacitor (Cout)
			Through Hole Electrolytic
3.3V	6V ~ 18V	47uh	470uf/25V

	6V ~36V	68uh	560uf/25V
5V	8V ~ 18V	33uh	330uf/25V
	8V ~36V	47uh	470uf/25V
9V	12V ~18V	47uh	330uf/25V
	12V ~36V	47uh	470uf/25V
12V	15V ~ 18V	47uh	220uf/25V
	15V ~36V	47uh	330uf/25V

Table 2. Typical Application Buck Regulator Design Procedure

Function Description

Pin Functions

+V_{IN}

This is the positive input supply for the IC switching regulator. A suitable input bypass capacitor must be present at this pin to minimize voltage transients and to supply the switching currents needed by the regulator

Ground

Circuit ground.

Output

Internal switch. The voltage at this pin switches between $(+V_{IN} - V_{SAT})$ and approximately $-0.5V$, with a duty cycle of approximately V_{OUT} / V_{IN} . To minimize coupling to sensitive circuitry, the PC board copper area connected to this pin should be kept a minimum.

Feedback

Senses the regulated output voltage to complete the feedback loop.

ON/OFF

Allows the switching regulator circuit to be shutdown using logic level signals thus dropping the total input supply current to approximately 80uA. Pulling this pin below a threshold voltage of approximately 1.3V turns the regulator on, and pulling this pin above 1.3V (up to a maximum of 25V) shuts the regulator down. If this shutdown feature is not needed, the ON /OFF pin can be wired to the ground pin or it can be left open, in either case the regulator will be in the ON condition.

Thermal Considerations

The TD1507 is available in TO252-5L package.

The TO252 package needs a heat sink under most conditions. The size of the heatsink depends on the input voltage, the output voltage, the load current and the ambient temperature. The TD1507 junction temperature rises above ambient temperature for a 2.5A load and different input and output voltages. The data for these curves was taken with the TD1507 (TO252

package) operating as a buck switching regulator in an ambient temperature of 25°C (still air). These temperature rise numbers are all approximate and there are many factors that can affect these temperatures. Higher ambient temperatures require more heat sinking.

The TO252 surface mount package tab is designed to be soldered to the copper on a printed circuit board. The copper and the board are the heat sink for this package and the other heat producing components, such as the catch diode and inductor. The PC board copper area that the package is soldered to should be at least 0.4 in², and ideally should have 2 or more square inches of 2 oz. Additional copper area improves the thermal characteristics, but with copper areas greater than approximately 6 in², only small improvements in heat dissipation are realized. If further thermal improvements are needed, double sided, multilayer PC board with large copper areas and/or airflow are recommended.

The TD1507 (TO252 package) junction temperature rise above ambient temperature with a 2.5A load for various input and output voltages. This data was taken with the circuit operating as a buck switching regulator with all components mounted on a PC board to simulate the junction temperature under actual operating conditions. This curve can be used for a quick check for the approximate junction temperature for various conditions, but be aware that there are many factors that can affect the junction temperature. When load currents higher than 2.5A are used, double sided or multilayer PC boards with large copper areas and/or airflow might be needed, especially for high ambient temperatures and high output voltages.

For the best thermal performance, wide copper traces and generous amounts of printed circuit board copper should be used in the board layout. (Once exception to this is the output (switch) pin, which should not have large areas of copper.) Large areas of copper provide the best transfer of heat (lower thermal resistance) to the surrounding air, and moving air lowers the thermal resistance even further.

Package Information

Package Type: TO252-5L

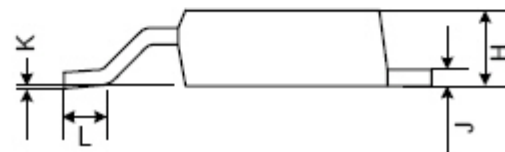
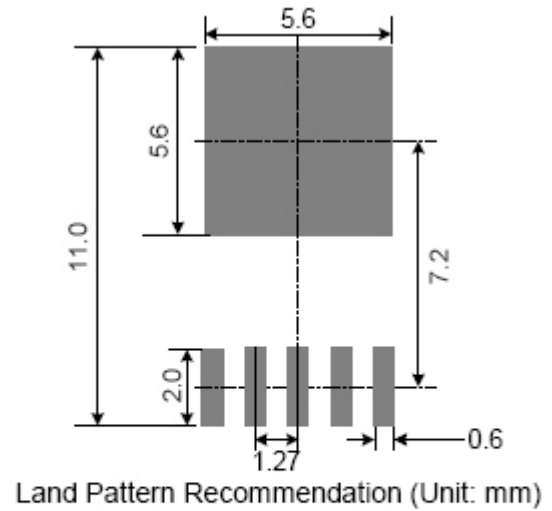
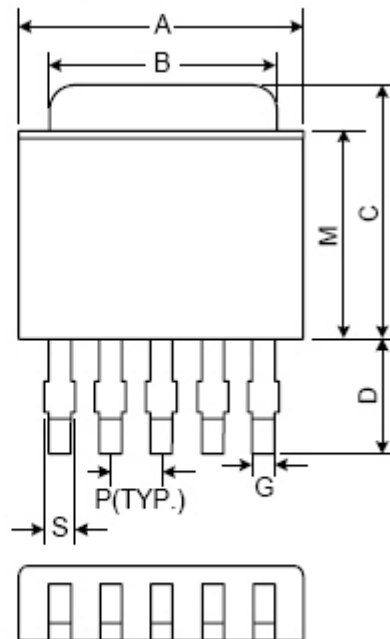

Symbol	Dimensions In Millimeters			Dimensions In Inches		
	Min.	Nom.	Max.	Min.	Nom.	Max.
A	6.35	6.60	6.85	0.250	0.260	0.270
B	5.20	5.35	5.50	0.205	0.211	0.217
C	6.80	7.00	7.30	0.268	0.276	0.287
D	2.20	2.50	2.80	0.087	0.098	0.110
P	1.27 REF.			0.050 REF.		
S	0.50	0.65	0.80	0.020	0.026	0.031
G	0.40	0.50	0.63	0.016	0.020	0.025
H	2.20	2.30	2.40	0.087	0.091	0.094
J	0.45	0.52	0.58	0.018	0.020	0.023
K	0.00	0.08	0.15	0.000	0.003	0.006
L	0.90	1.20	1.63	0.035	0.047	0.064
M	5.40	5.80	6.20	0.213	0.228	0.244

Design Notes