



# FSFR-Series / FSFR2100

## Fairchild Power Switch (FPS™) for Half-Bridge Resonant Converter

### Features

- Variable Frequency Control with 50% Duty Cycle for Half-bridge Resonant Converter Topology
- High Efficiency through Zero Voltage Switching (ZVS)
- Internal Super-FETs with Fast-Recovery Type Body Diode ( $t_r=120ns$ )
- Fixed Dead Time (350ns) Optimized for MOSFETs
- Up to 300kHz Operating Frequency
- Pulse Skipping for Frequency Limit (Programmable) at Light-Load Condition
- Remote On/Off Control Using Control Pin
- Protection Functions: Over-Voltage Protection (OVP), Overload Protection (OLP), Over-Current Protection (OCP), Abnormal Over-Current Protection (AOCP), Internal Thermal Shutdown (TSD)

### Applications

- PDP TV and LCD TV
- Desktop PC and Server
- Adapter
- Telecom Power
- Audio Power

### Description

FSFR-series is a highly integrated power switch family specially designed for high-efficiency half-bridge resonant converters. Offering everything necessary to build a reliable and robust resonant converter, the FSFR-series simplifies designs and improves productivity, while improving performance. The FSFR-series combines power MOSFETs with fast-recovery type body diodes, a high-side gate-drive circuit, an accurate current controlled oscillator, frequency limit circuit, soft-start, and built-in protection functions. The high-side drive circuit has a common-mode noise cancellation capability, which guarantees stable operation with excellent noise immunity. The fast-recovery body diode of the MOSFETs improves reliability against abnormal operation conditions, while minimizing the effect of the reverse recovery. Using the zero-voltage-switching (ZVS) technique dramatically reduces the switching losses and the efficiency is significantly improved. The ZVS also reduces the switching noise noticeably, which allows a small-sized EMI filter.

The FSFR-series can be applied to various resonant converter topologies such as series resonant, parallel resonant, and LLC resonant converters.

### Related Resources

[AN4151 — Half-bridge LLC Resonant Converter Design using FSFR-series Fairchild Power Switch \(FPS™\)](#)

### Ordering Information

Part Number	Package	Operating Temperature	$R_{DS(ON\_MAX)}$	Maximum Output Power without Heatsink ( $V_{IN}=350\sim 400V$ ) <sup>(1,2)</sup>	Maximum Output Power with Heatsink ( $V_{IN}=350\sim 400V$ ) <sup>(1,2)</sup>
FSFR2100	9-SIP	-40 to +85°C	0.38Ω	200W	450W
FSFR2000 <sup>(3)</sup>	9-SIP	-40 to +85°C	0.67Ω	160W	350W
FSFR1900 <sup>(3)</sup>	9-SIP	-40 to +85°C	0.85Ω	140W	300W
FSFR1800 <sup>(3)</sup>	9-SIP	-40 to +85 °C	0.95Ω	120W	260W

#### Notes:

1. The junction temperature can limit the maximum output power.
  2. Maximum practical continuous power in an open-frame design at 50°C ambient.
  3. Preliminary part design. Contact a Fairchild representative for availability.
-  All packages are lead free per JEDEC: J-STD-020B standard.

### Application Circuit Diagram

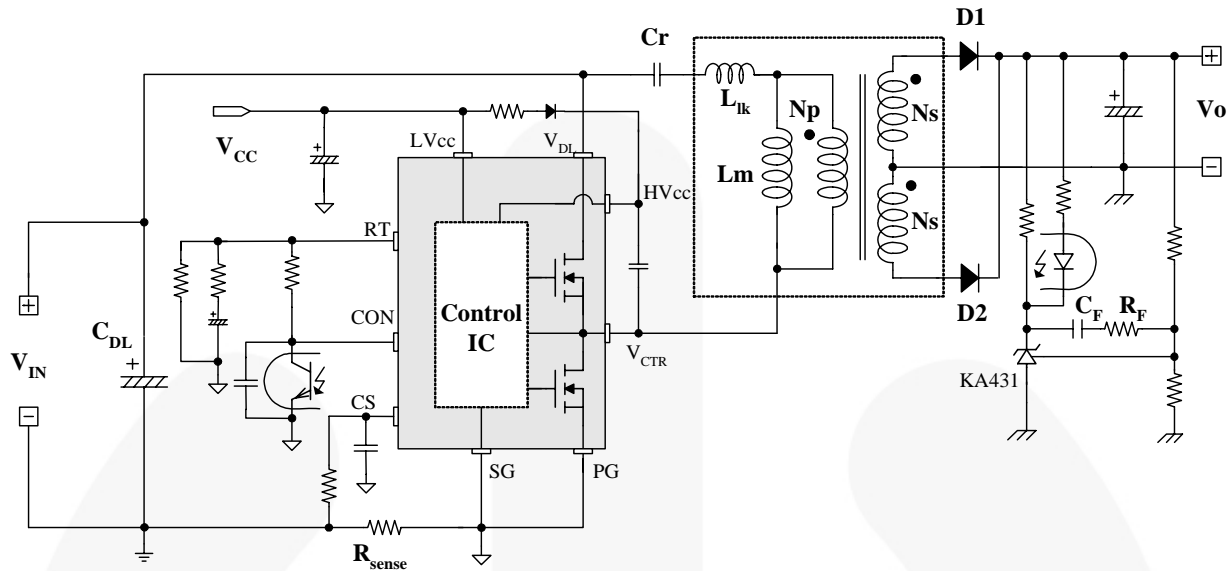

Figure 1. Typical Application Circuit (LLC Resonant Half-bridge Converter)



tonyli@rslgroup.com.cn  
 FAX: 0755-88262655  
 www.rslgroup.com.cn

### Block Diagram

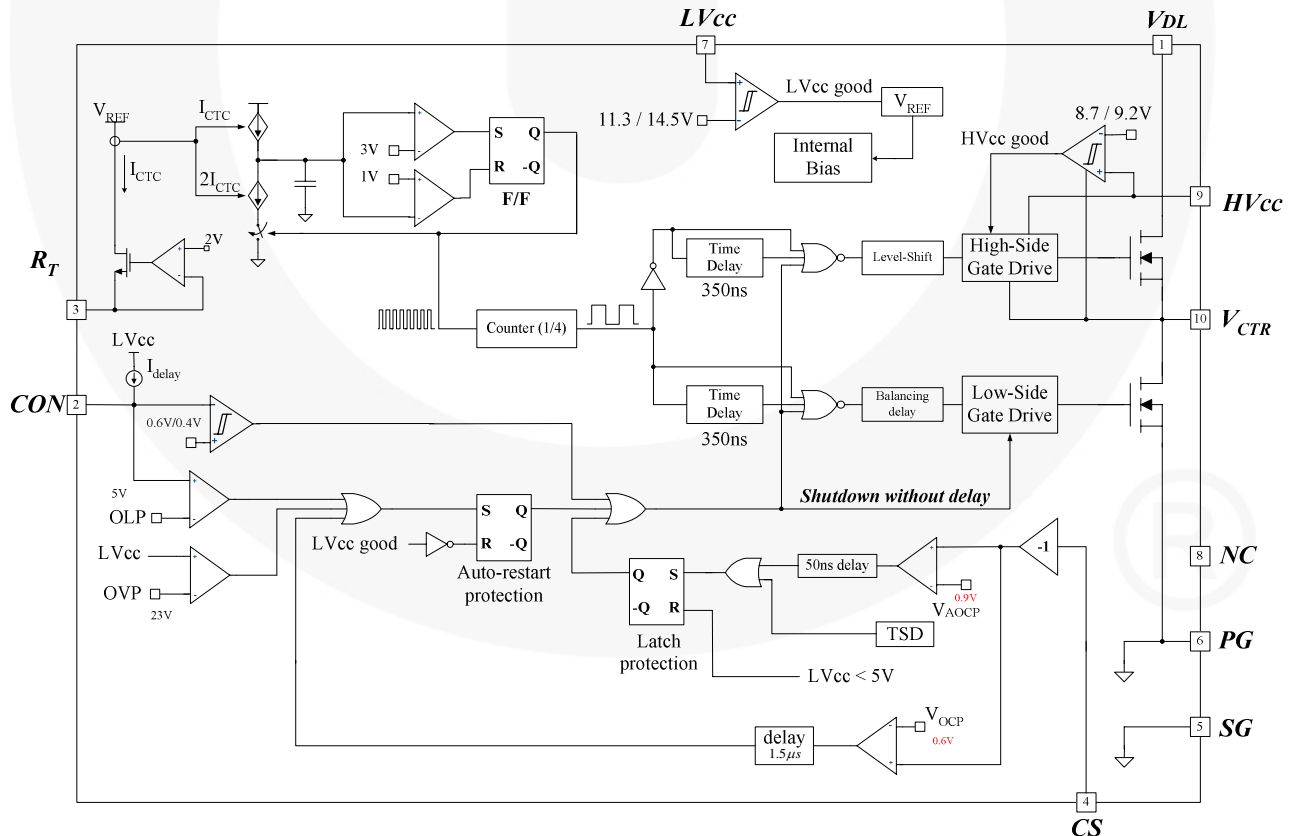

Figure 2. Internal Block Diagram

## Pin Assignments

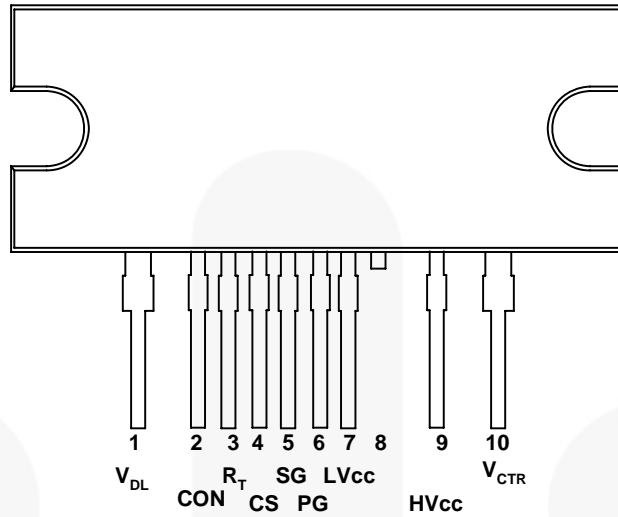

Figure 3. Package Diagram



[tonyli@rslgroup.com.cn](mailto:tonyli@rslgroup.com.cn)  
 FAX: 0755-88262655  
[www.rslgroup.com.cn](http://www.rslgroup.com.cn)

## Pin Definitions

Pin #	Name	Description
1	$V_{DL}$	This pin is the drain of the high-side MOSFET. It is typically connected to the input DC link voltage.
2	CON	This pin is for enable/disable and protection. When the voltage of this pin is above 0.6V, the IC operation is enabled. When the voltage of this pin drops below 0.4V, gate drive signals for both MOSFETs are disabled. When the voltage of this pin increases above 5V, protection is triggered.
3	$R_T$	This pin programs the switching frequency. Typically, an opto-coupler is connected to control the switching frequency for the output voltage regulation.
4	CS	This pin senses the current flowing through the low-side MOSFET. Typically, negative voltage is applied on this pin.
5	SG	This pin is the control ground.
6	PG	This pin is the power ground. This pin is connected to the source of the low-side MOSFET.
7	$LV_{cc}$	This pin is the supply voltage of the control IC.
8	NC	No connection.
9	$HV_{cc}$	This pin is the supply voltage of the high-side drive circuit IC.
10	$V_{CTR}$	This pin is the drain of the low-side MOSFET. Typically, a transformer is connected to this pin.

## Absolute Maximum Ratings

Stresses exceeding the absolute maximum ratings may damage the device. The device may not function or be operable above the recommended operating conditions and stressing the parts to these levels is not recommended. In addition, extended exposure to stresses above the recommended operating conditions may affect device reliability. The absolute maximum ratings are stress ratings only.  $T_A=25^{\circ}\text{C}$  unless otherwise specified.

Symbol	Parameter	Min.	Max.	Unit
$V_{DS}$	Maximum Drain-to-source Voltage ( $V_{DL}-V_{CTR}$ and $V_{CTR}-PG$ )	600		V
$LV_{CC}$	Low-side Supply Voltage	-0.3	25.0	V
$HV_{CC}$ to $V_{CTR}$	High-side $V_{CC}$ Pin to Low-side Drain Voltage	-0.3	25.0	V
$HV_{CC}$	High-side Floating Supply Voltage	-0.3	625.0	V
$V_{CON}$	Control Pin Input Voltage	-0.3	$L-V_{CC}$	V
$V_{CS}$	Current Sense (CS) Pin Input Voltage	-5.0	1.0	V
$V_{RT}$	$R_T$ Pin Input Voltage	-0.3	5.0	V
$dV_{CTR}/dt$	Allowable Low-side MOSFET Drain Voltage Slew Rate		50	V/ns
$P_D$	Total Power Dissipation <sup>(4)</sup>		12	W
$T_J$	Operating Junction Temperature		+150	$^{\circ}\text{C}$
$T_A$	Operating Ambient Temperature	-40	+85	$^{\circ}\text{C}$
$T_{STG}$	Storage Temperature Range	-55	+150	$^{\circ}\text{C}$
<b>MOSFET Section</b>				
$V_{DGR}$	Drain Gate Voltage ( $R_{GS}=1M\Omega$ )	600		V
$V_{GS}$	Gate Source (GND) Voltage		$\pm 30$	V
$I_{DM}$	Drain Current Pulsed		33	A
$I_D$	Continuous Drain Current	$T_C=25^{\circ}\text{C}$	11	A
		$T_C=100^{\circ}\text{C}$	7	

**Note:**

4. Per MOSFET when both MOSFETs are conducting.



tonyli@rslgroup.com.cn  
 FAX: 0755-88262655  
 www.rslgroup.com.cn

## Thermal Impedance

$T_A=25^{\circ}\text{C}$  unless otherwise specified.

Symbol	Parameter	Value	Unit
$\theta_{JC}$	Junction-to-Case Center Thermal Impedance (Both MOSFETs Conducting)	10.44	$^{\circ}\text{C}/\text{W}$



## Electrical Characteristics

T<sub>A</sub>=25°C unless otherwise specified.

Symbol	Parameter	Test Conditions	Specifications			Unit
			Min.	Typ.	Max.	
<b>MOSFET Section</b>						
BV <sub>DSS</sub>	Drain-to-Source Breakdown Voltage	I <sub>D</sub> =200μA, T <sub>A</sub> =25°C	600			V
		I <sub>D</sub> =200μA, T <sub>A</sub> =125°C		650		V
R <sub>DS(ON)</sub>	On-State Resistance	V <sub>GS</sub> =10, I <sub>D</sub> =5.5A		0.32	0.38	Ω
T <sub>rr</sub>	Body Diode Reverse Recovery Time <sup>(5)</sup>			120		ns
<b>Supply Section</b>						
I <sub>LK</sub>	Offset Supply Leakage Current	H-Vcc=VC=600V			50	μA
I <sub>QHVC</sub>	Quiescent H-Vcc Supply Current	(H-VCCUV+) - 0.1V		50	120	μA
I <sub>QLVC</sub>	Quiescent L-Vcc Supply Current	(L-VCCUV+) - 0.1V		100	200	μA
I <sub>OHVC</sub>	Operating H-Vcc Supply Current (RMS Value)	F <sub>OSC</sub> =100KHz, V <sub>CON</sub> > 0.6V		6	9	mA
		No switching, V <sub>CON</sub> < 0.4V		100	200	μA
I <sub>OLVC</sub>	Operating L-Vcc Supply Current (RMS Value)	F <sub>OSC</sub> =100KHz, V <sub>CON</sub> > 0.6V		7	11	mA
		No switching, V <sub>CON</sub> < 0.4V		2	4	mA
<b>UVLO Section</b>						
LV <sub>CCUV+</sub>	L-Vcc Supply Under-voltage Positive Going Threshold (L-Vcc start)		13.0	14.5	16.0	V
LV <sub>CCUV-</sub>	L-Vcc Supply Under-voltage Negative Going Threshold (L-Vcc stop)		10.2	11.3	12.4	V
LV <sub>CCUVH</sub>	L-Vcc Supply Under-voltage Hysteresis			3.2		V
HV <sub>CCUV+</sub>	H-Vcc Supply Under-voltage Positive Going Threshold (H-Vcc start)		8.2	9.2	10.2	V
HV <sub>CCUV-</sub>	H-Vcc Supply Under-voltage Negative Going Threshold (H-Vcc stop)		7.8	8.7	9.6	V
HV <sub>CCUVH</sub>	H-Vcc Supply Under-voltage Hysteresis			0.5		V
<b>Oscillator &amp; Feedback Section</b>						
V <sub>CONDIS</sub>	Control Pin Disable Threshold Voltage		0.36	0.40	0.44	V
V <sub>CONEN</sub>	Control Pin Enable Threshold Voltage		0.54	0.60	0.66	V
V <sub>RT</sub>	V-I Converter Threshold Voltage		1.5	2.0	2.5	V
F <sub>OSC</sub>	Output Oscillation Frequency	R <sub>T</sub> =5.2KΩ	94	100	106	KHz
DC	Output Duty Cycle		48	50	52	%
F <sub>SS</sub>	Internal Soft-Start Initial Frequency	F <sub>SS</sub> =F <sub>OSC</sub> +40kHz, R <sub>T</sub> =5.2KΩ		140		KHz
T <sub>SS2</sub>	Internal Soft-Start Time		2	3	4	ms

**Note:**

5. This parameter, although guaranteed, is not tested.



tonyli@rslgroup.com.cn  
 FAX: 0755-88262655  
 www.rslgroup.com.cn

Continued on the following page...

## Electrical Characteristics (Continued)

T<sub>A</sub>=25°C unless otherwise specified.



tonyli@rslgroup.com.cn  
 FAX: 0755-88262655  
 www.rslgroup.com.cn

FSFR-Series — Fairchild Power Switch (FPS™) for Half-Bridge Resonant Converter

Symbol	Parameter	Test Conditions	Specifications			Unit
			Min	Typ	Max	
<b>Protection Section</b>						
I <sub>OLP</sub>	OLP Delay Current	V <sub>CON</sub> =4V	3.6	4.8	6.0	μA
V <sub>OLP</sub>	OLP Protection Voltage	V <sub>CON</sub> > 3.5V	4.5	5.0	5.5	V
V <sub>OVP</sub>	L-Vcc Over-Voltage Protection	L-Vcc > 21V	21	23	25	V
V <sub>AACP</sub>	AACP Threshold Voltage	ΔV/Δt=-1V/μs	-1.0	-0.9	-0.8	V
T <sub>BAO</sub>	AACP Blanking Time <sup>(6)</sup>	V <sub>CS</sub> < V <sub>OCP</sub> ; ΔV/Δt=-1V/us		50		ns
V <sub>OCP</sub>	OCP Threshold Voltage	(V)/(t=-1V/μs; V <sub>FB</sub> =L_Vcc	-0.64	-0.58	-0.52	V
T <sub>BO</sub>	OCP Blanking Time <sup>(6)</sup>	V <sub>CS</sub> < V <sub>OCP</sub> ; ΔV/Δt=-1V/μs; V <sub>FB</sub> =L_Vcc	1.0	1.5	2.0	μs
T <sub>DA</sub>	Delay Time (Low Side) Detecting from V <sub>AACP</sub> to Switch Off <sup>(6)</sup>	ΔV/Δt=-1V/μs		250	400	ns
T <sub>SD</sub>	Thermal Shutdown Temperature <sup>(6)</sup>		110	130	150	°C
I <sub>SU</sub>	Protection Latch Sustain L-Vcc Supply Current	L-Vcc=7.5V		100	150	μA
V <sub>PRSET</sub>	Protection Latch Reset L-Vcc Supply Voltage		5			V
<b>Dead-Time Control Section</b>						
D <sub>T</sub>	Dead Time <sup>(7)</sup>			350		ns

**Notes:**

6. These parameters, although guaranteed, are not tested in production.
7. These parameters, although guaranteed, are tested only in EDS (wafer test) process.



## Typical Performance Characteristics

These characteristic graphs are normalized at  $T_A=25^\circ\text{C}$ .

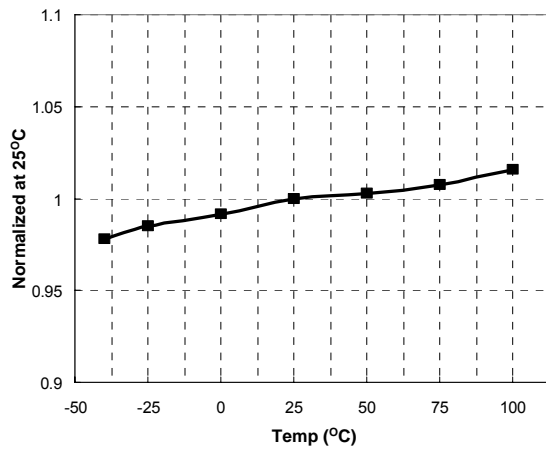

Figure 4. Low-side MOSFET Duty Cycle vs. Temp.

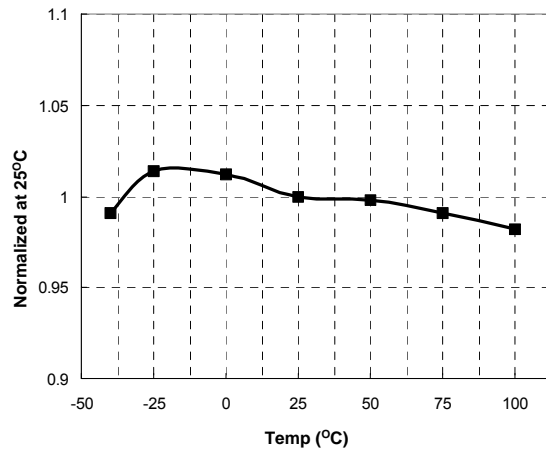

Figure 5. Switching Frequency vs. Temp.

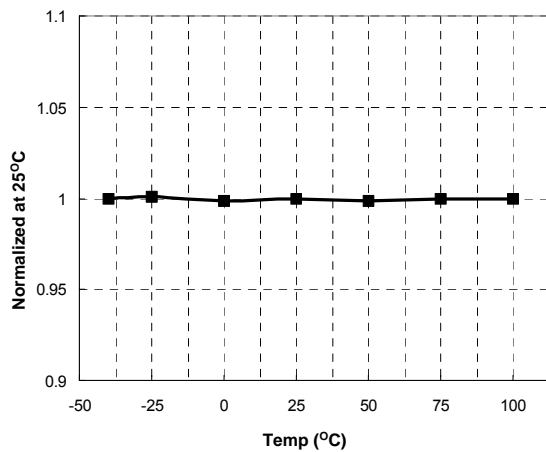

Figure 6. High-side  $V_{CC}$  (H-Vcc) Start vs. Temp.

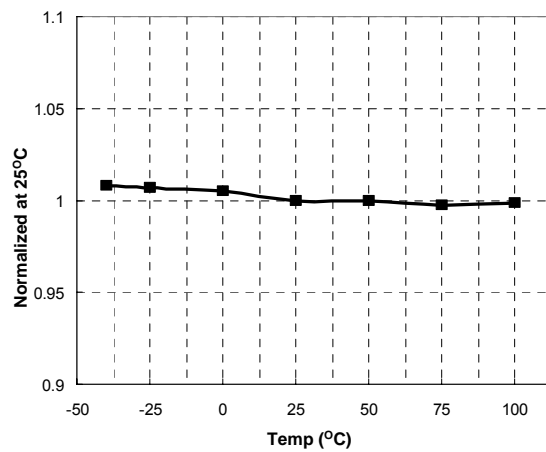

Figure 7. High-side  $V_{CC}$  (H-Vcc) Stop vs. Temp.

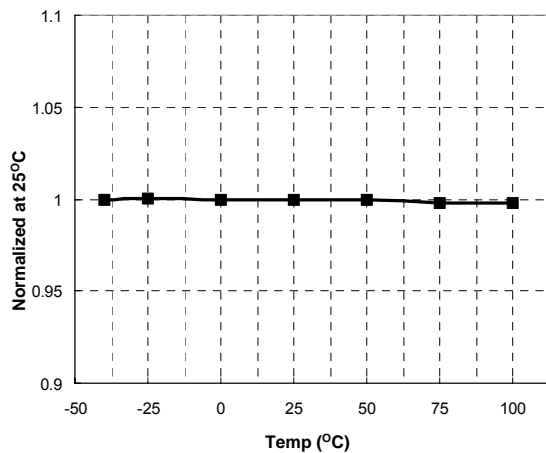

Figure 8. Low-side  $V_{CC}$  (L-Vcc) Start vs. Temp.

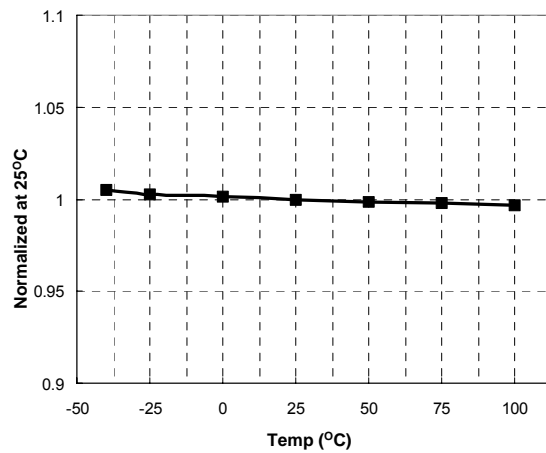

Figure 9. Low-side  $V_{CC}$  (L-Vcc) Stop vs. Temp.



### Typical Performance Characteristics (Continued)

These characteristic graphs are normalized at  $T_A=25^\circ\text{C}$ .

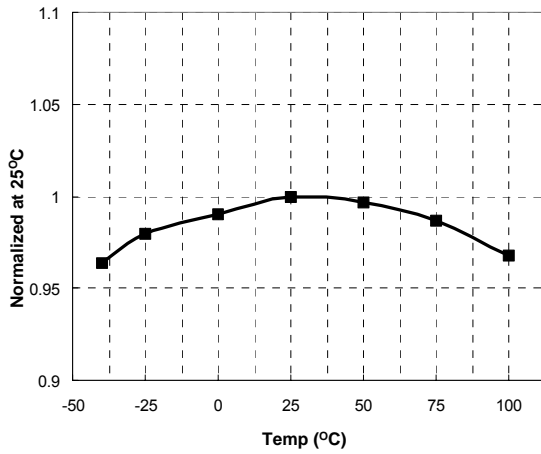

Figure 10. OLP Delay Current vs. Temp.

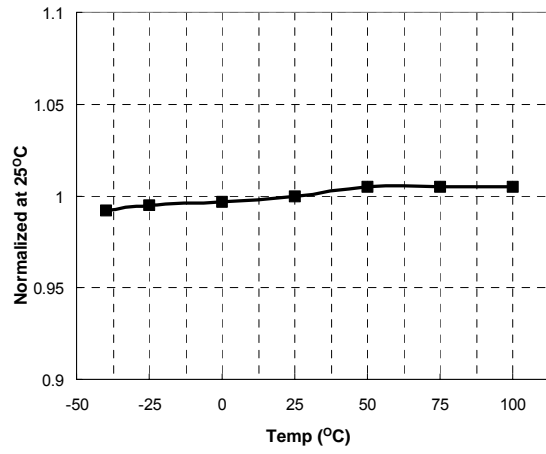

Figure 11. OLP Protection Voltage vs. Temp.

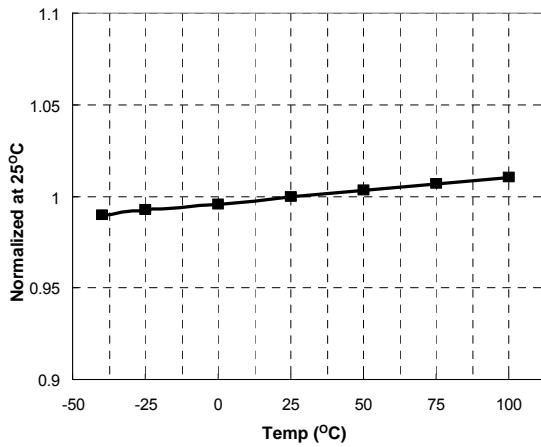

Figure 12. L-Vcc OVP Voltage vs. Temp.

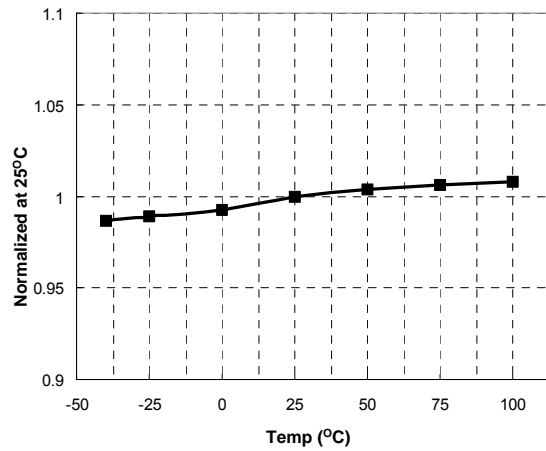

Figure 13. V-I Converter Voltage vs. Temp.

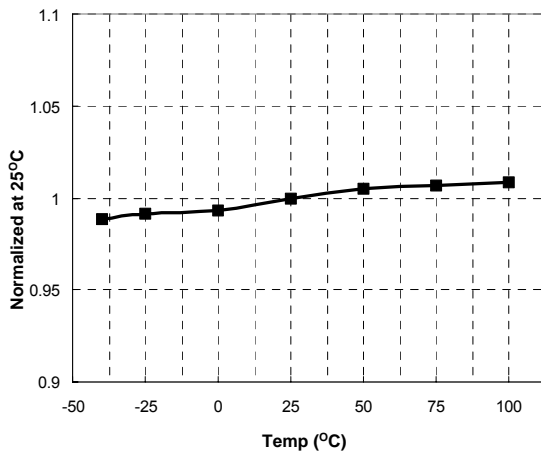

Figure 14. CON Pin Enable Voltage vs. Temp.

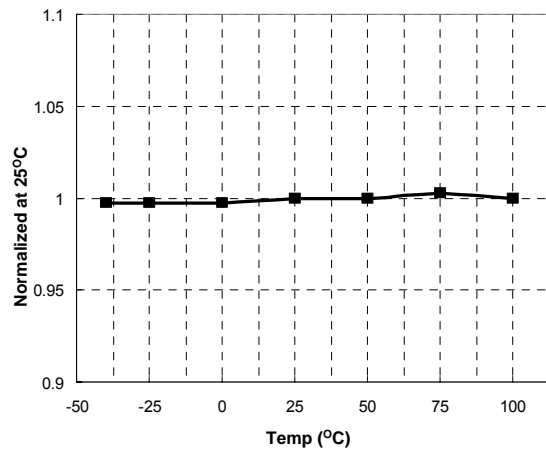

Figure 15. Current Limit vs. Temp.



## Functional Description

**1. Basic Operation:** FSFR-series is designed to drive high-side and low-side MOSFETs complementarily with 50% duty cycle. A fixed dead time of 350ns is introduced between consecutive transitions, as shown in Figure 16.

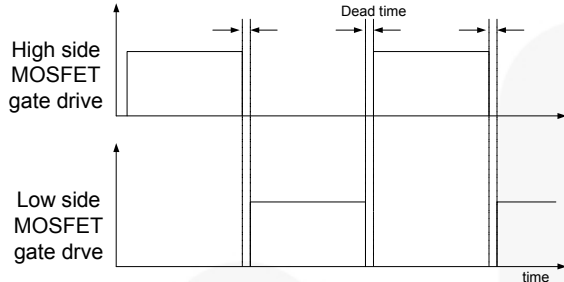

Figure 16. MOSFETs Gate Drive Signal

**2. Internal Oscillator:** FSFR-series employs a current-controlled oscillator, as shown in Figure 17. Internally, the voltage of  $R_T$  pin is regulated at 2V and the charging/discharging current for the oscillator capacitor,  $C_T$ , is obtained by copying the current flowing out of  $R_T$  pin ( $I_{CTC}$ ) using a current mirror. Therefore, the switching frequency increases as  $I_{CTC}$  increases.

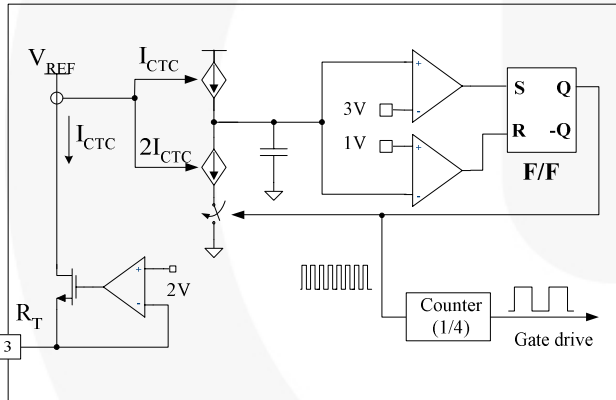

Figure 17. Current Controlled Oscillator

**3. Frequency Setting:** Figure 18 shows the typical voltage gain curve of a resonant converter, where the gain is inversely proportional to the switching frequency. The output voltage can be regulated by modulating the switching frequency. Figure 19 shows the typical circuit configuration for  $R_T$  pin, where the opto-coupler transistor is connected to the  $R_T$  pin to modulate the switching frequency.

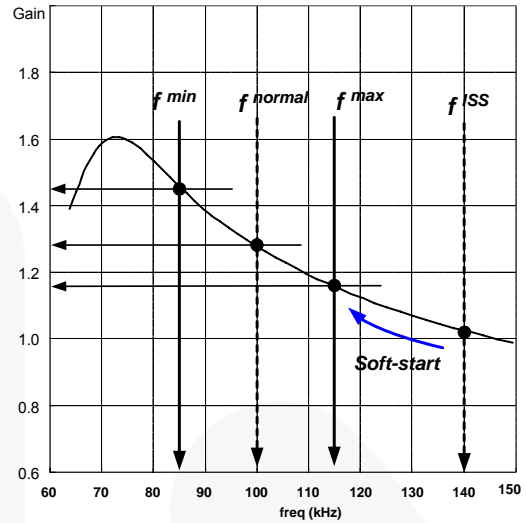

Figure 18. Resonant Converter Typical Gain Curve

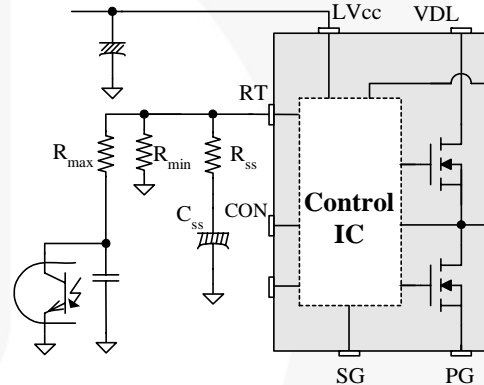

Figure 19. Frequency Control Circuit

The minimum switching frequency is determined as:

$$f_{\min} = \frac{5.2k\Omega}{R_{\min}} \times 100(kHz) \quad (1)$$

Assuming the saturation voltage of opto-coupler transistor is 0.2V, the maximum switching frequency is determined as:

$$f_{\max} = \left( \frac{5.2k\Omega}{R_{\min}} + \frac{4.68k\Omega}{R_{\max}} \right) \times 100(kHz) \quad (2)$$

To prevent excessive inrush current and overshoot of output voltage during start-up, increase the voltage gain of the resonant converter progressively. Since the voltage gain of the resonant converter is inversely proportional to the switching frequency, the soft-start is implemented by sweeping down the switching frequency from an initial high frequency ( $f_{ISS}$ ) until the output voltage is established. The soft-start circuit is made by connecting R-C series network on the  $R_T$  pin, as shown in Figure 19. FSFR-series also has an internal soft-start for 3ms to reduce the current overshoot during the initial



tonyli@rslgroup.com.cn  
 FAX:0755-88262655  
 www.rslgroup.com.cn

cycles, which adds 40kHz to the initial frequency of the external soft-start circuit, as shown in Figure 20. Thus, the initial frequency of the soft-start is given as:

$$f^{ISS} = \left( \frac{5.2k\Omega}{R_{min}} + \frac{5.2k\Omega}{R_{SS}} \right) \times 100 + 40 \text{ (kHz)} \quad (3)$$

It is typical to set the initial frequency of soft-start 2~3 times the resonant frequency ( $f_0$ ) of the resonant network.

The soft-start time is determined by the RC time constant as:

$$T_{SS} = R_{SS} \cdot C_{SS} \quad (4)$$

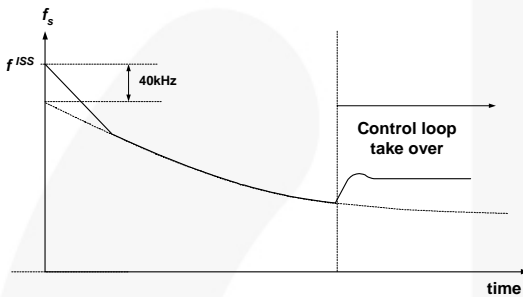

Figure 20. Frequency Sweeping of Soft-start

**4. Control Pin:** The FSFR-series has a control pin that can be used for protection, cycle skipping, and remote on/off. Figure 21 shows the internal block diagram for control pin.

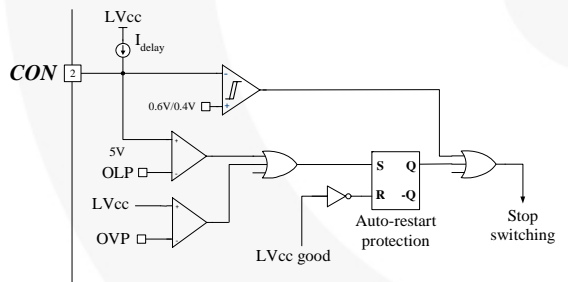

Figure 21. Internal Block of Control Pin

**Protection:** When the control pin voltage exceeds 5V, protection is triggered. Detailed applications are described in the protection section.

**Pulse Skipping:** FSFR-series stops switching when the control pin voltage drops below 0.4V and resumes switching when the control pin voltage rises above 0.6V. To use pulse-skipping, the control pin should be connected to the opto-coupler collector pin. The frequency that causes pulse skipping is given as:

$$f^{SKIP} = \left( \frac{5.2k\Omega}{R_{min}} + \frac{4.16k\Omega}{R_{max}} \right) \times 100 \text{ (kHz)} \quad (5)$$

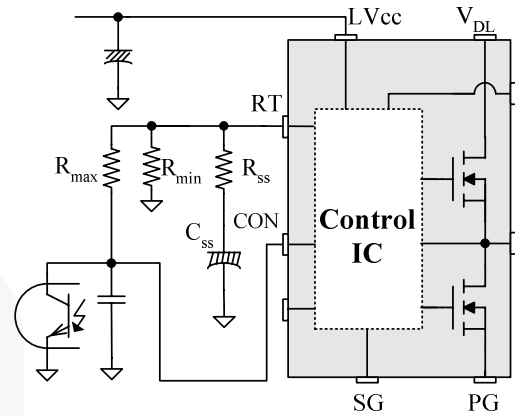

Figure 22. Control Pin Configuration for Pulse Skipping

**Remote On / Off:** When an auxiliary power supply is used for standby, the main power stage using FSFR-series can be shut down by pulling down the control pin voltage, as shown in Figure 23. R1 and C1 are used to ensure soft-start when switching resumes.

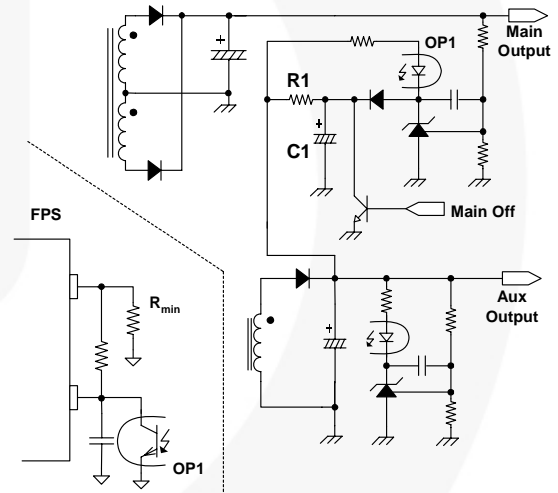

Figure 23. Remote On / Off Circuit

**5. Protection Circuits:** The FSFR-series has several self-protective functions, such as Overload Protection (OLP), Over-Current Protection (OCP), Abnormal Over-Current Protection (AOCP), Over-Voltage Protection (OVP), and Thermal Shutdown (TSD). OLP, OCP, and OVP are auto-restart mode protections, while AOCP and TSD are latch-mode protections, as shown in Figure 24.

**Auto-restart Mode Protection:** Once a fault condition is detected, switching is terminated and the MOSFETs remain off. When LVcc falls to the LVcc stop voltage of 11V, the protection is reset. The FPS resumes normal operation when LVcc reaches the start voltage of 14V.

**Latch-Mode Protection:** Once this protection is triggered, switching is terminated and the MOSFETs remain off. The latch is reset only when LVcc is discharged below 5V.

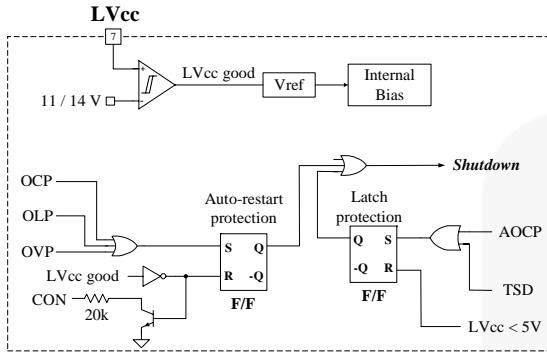

Figure 24. Protection Blocks

**Current Sensing Using Resistor:** FSFR-series senses drain current as a negative voltage, as shown in Figure 25 and Figure 26. Half-wave sensing allows low power dissipation in the sensing resistor while full-wave sensing has less switching noise in the sensing signal.

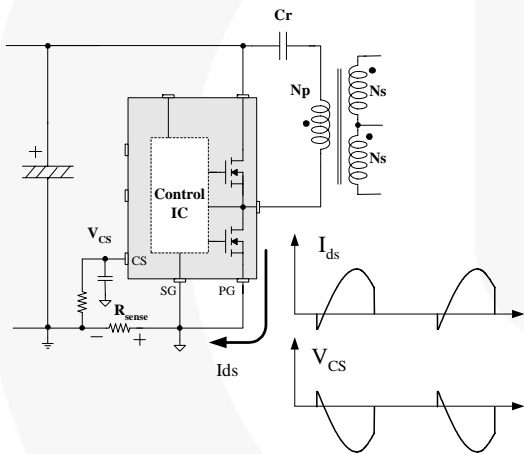

Figure 25. Half-wave Sensing

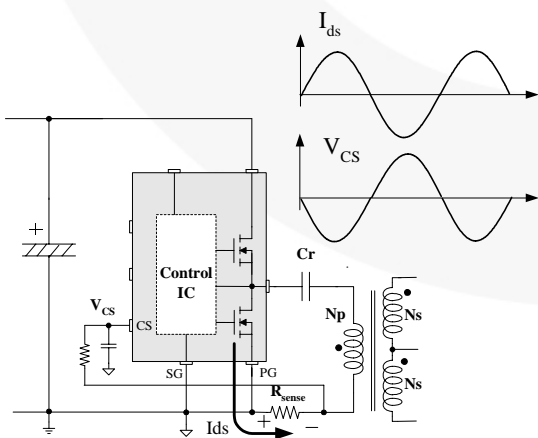

Figure 26. Full-wave Sensing

**Current Sensing Using Resonant Capacitor Voltage:** For high-power applications, current sensing using a resistor may not be available due to the severe power dissipation in the resistor. In that case, indirect current sensing using the resonant capacitor voltage can be a good alternative because the amplitude of the resonant capacitor voltage ( $V_{Cr}^{p-p}$ ) is proportional to the resonant current in the primary side ( $I_p^{p-p}$ ) as:

$$V_{Cr}^{p-p} = \frac{I_p^{p-p}}{2\pi f_s C_r} \quad (6)$$

To minimize power dissipation, a capacitive voltage divider is generally used for capacitor voltage sensing, as shown in Figure 27.

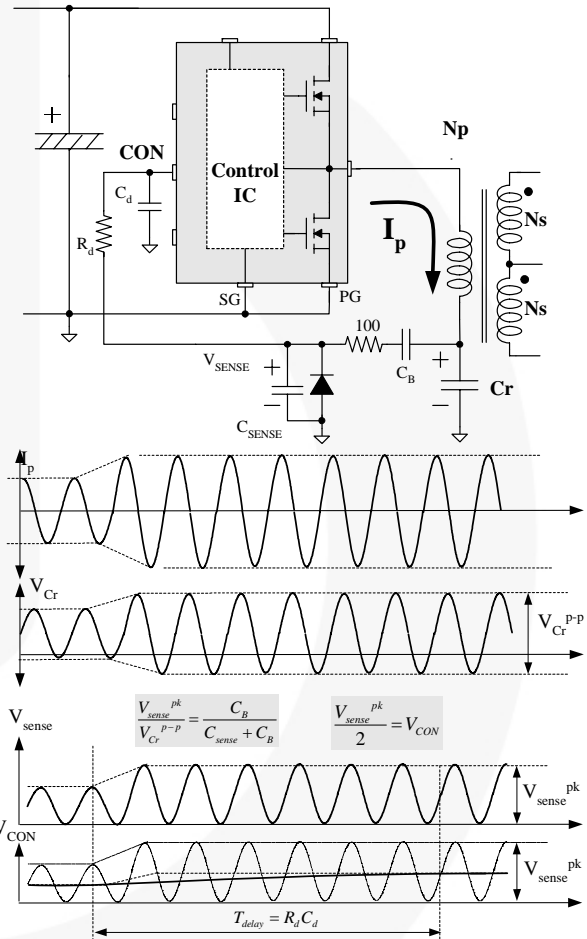

Figure 27. Current Sensing Using Resonant Capacitor Voltage

**5.1 Over-Current Protection (OCP):** When the sensing pin voltage drops below -0.6V, OCP is triggered and MOSFETs remain off. This protection has a shutdown time delay of 1.5μs to prevent premature shutdown during start-up.

**5.2 Abnormal Over-Current Protection (AOCPP):** If the secondary rectifier diodes are shorted, large current with extremely high di/dt can flow through the MOSFET before OCP or OLP is triggered. AOCPP is triggered without shutdown delay when the sensing pin voltage drops below -0.9V. This protection is latch mode and reset when LVcc is pulled down below 5V.

**5.3 Overload Protection (OLP):** Overload is defined as the load current exceeding its normal level due to an unexpected abnormal event. In this situation, the protection circuit should trigger to protect the power supply. However, even when the power supply is in the normal condition, the overload situation can occur during the load transition. To avoid premature triggering of protection, the overload protection circuit should be designed to trigger only after a specified time to determine whether it is a transient situation or a true overload situation. Figure 27 shows a typical overload protection circuit. By sensing the resonant capacitor voltage on the control pin, the overload protection can be implemented. Using RC time constant, shutdown delay can be also introduced. The voltage obtained on the control pin is given as:

$$V_{CON} = \frac{C_B}{2(C_B + C_{sense})} V_{Cr}^{p-p} \quad (7)$$

where  $V_{Cr}^{p-p}$  is the amplitude of the resonant capacitor voltage.

**5.4 Over-Voltage Protection (OVP):** When the LVcc reaches 23V, OVP is triggered. This protection is used when auxiliary winding of the transformer to supply Vcc to FPS is utilized.

**5.5 Thermal Shutdown (TSD):** The MOSFETs and the control IC in one package makes it easy for the control IC to detect the abnormal over-temperature of the MOSFETs. If the temperature exceeds approximately 130°C, the thermal shutdown triggers.

**RSL**

tonyli@rslgroup.com.cn  
 FAX: 0755-88262655  
 www.rslgroup.com.cn



### Typical Application Circuit (Half-bridge LLC Resonant Converter)

Application	FPS™ Device	Input Voltage Range	Rated Output Power	Output Voltage (Rated Current)
LCD TV	FSFR2100	400V (20ms hold-up time)	192W	24V-8A



tonyli@rslgroup.com.cn  
 FAX: 0755-88262655  
 www.rslgroup.com.cn

#### Features

- High efficiency (>94% at 400V<sub>DC</sub> input)
- Reduced EMI noise through zero-voltage-switching (ZVS)
- Enhanced system reliability with various protection functions

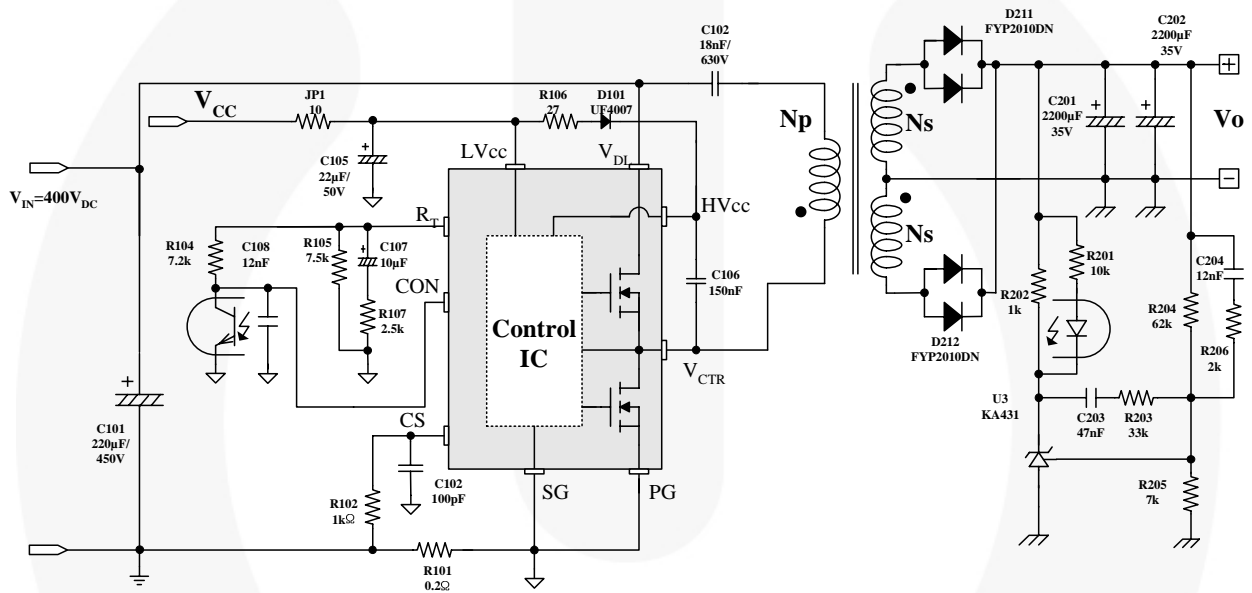

Figure 28. Typical Application Circuit

### Typical Application Circuit (Continued)

Usually, LLC resonant converter requires large leakage inductance value. To obtain a large leakage inductance, sectional winding method is used.

- Core: EER3542 ( $A_e=107 \text{ mm}^2$ )
- Bobbin: EER3542 (Horizontal)



tonyli@rslgroup.com.cn  
 FAX: 0755-88262655  
 www.rslgroup.com.cn

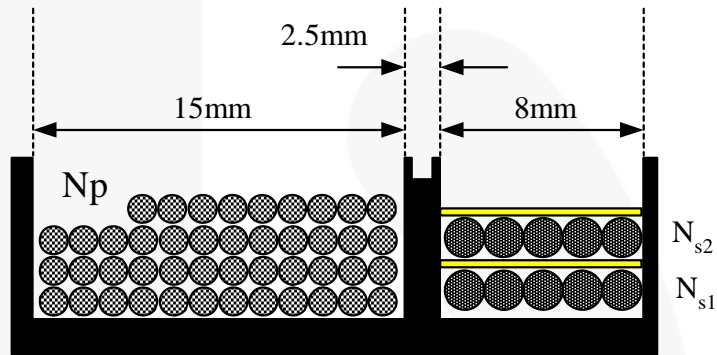
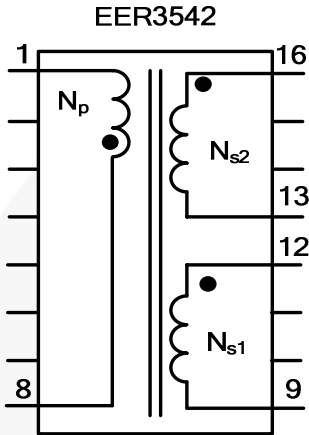

	Pin(S → F)	Wire	Turns	Winding Method
$N_p$	8 → 1	0.12φ×30 (Litz wire)	45	Section winding
$N_{s1}$	12 → 9	0.1φ×100 (Litz wire)	5	Section winding
$N_{s2}$	16 → 13	0.1φ×100 (Litz wire)	5	Section winding

	Pin	Specification	Remark
Primary-side Inductance ( $L_p$ )	1-8	630μH ± 5%	100kHz, 1V
Primary-side Effective Leakage ( $L_R$ )	1-8	145μH ± 5%	Short one of the secondary windings



RSL

tonyli@rslgroup.com.cn  
FAX:0755-88262655  
www.rslgroup.com.cn



RSL

tonyli@rslgroup.com.cn  
FAX:0755-88262655  
www.rslgroup.com.cn



TRADEMARKS

The following are registered and unregistered trademarks and service marks Fairchild Semiconductor owns or is authorized to use and is not intended to be an exhaustive list of all such trademarks.

ACE<sup>®</sup>  
Build it Now<sup>™</sup>  
CorePLUS<sup>™</sup>  
CROSSVOLT<sup>™</sup>  
CTL<sup>™</sup>  
Current Transfer Logic<sup>™</sup>  
EcoSPARK<sup>®</sup>  
F<sup>®</sup>  
Fairchild<sup>®</sup>  
Fairchild Semiconductor<sup>®</sup>  
FACT Quiet Series<sup>™</sup>  
FACT<sup>®</sup>  
FAST<sup>®</sup>  
FastvCore<sup>™</sup>  
FPST<sup>™</sup>  
FRFET<sup>®</sup>  
Global Power Resource<sup>SM</sup>

Green FPS<sup>™</sup>

Power247<sup>®</sup>

SuperSOT<sup>™</sup>-8

RSL

tonyli@rslgroup.com.cn  
FAX:0755-88262655  
www.rslgroup.com.cn

MegaBuck<sup>™</sup>  
MICROCOUPLER<sup>™</sup>  
MicroFET<sup>™</sup>

QS<sup>™</sup>  
QT Optoelectronics<sup>™</sup>  
Quiet Series<sup>™</sup>

Franchise<sup>®</sup>  
TinyBuck<sup>™</sup>  
TinyLogic<sup>®</sup>  
TINYOPTO<sup>™</sup>

RSL

tonyli@rslgroup.com.cn  
FAX:0755-88262655  
www.rslgroup.com.cn

PDP-SPM<sup>™</sup>  
Power220<sup>®</sup>

SuperSOT<sup>™</sup>-3  
SuperSOT<sup>™</sup>-6

UniFET<sup>™</sup>  
VCX<sup>™</sup>

RSL

tonyli@rslgroup.com.cn  
FAX:0755-88262655  
www.rslgroup.com.cn

DISCLAIMER

FAIRCHILD SEMICONDUCTOR PROVIDES THESE PRODUCTS HEREIN TO IMPROVE RELIABILITY, FUNCTION, OR DESIGN. FAIRCHILD DOES NOT ASSUME ANY LIABILITY ARISING OUT OF THE APPLICATION OR USE OF ANY PRODUCT OR CIRCUIT DESCRIBED HEREIN; NEITHER DOES IT CONVEY ANY LICENSE UNDER ITS PATENT RIGHTS, NOR THE RIGHTS OF OTHERS. THESE SPECIFICATIONS DO NOT EXPAND THE TERMS OF FAIRCHILD'S WORLDWIDE TERMS AND CONDITIONS OF SALE FOR THESE PRODUCTS.

RSL

tonyli@rslgroup.com.cn  
FAX:0755-88262655  
www.rslgroup.com.cn

LIFE SUPPORT POLICY

FAIRCHILD'S PRODUCT SYSTEMS WITHOUT THE EXPRESS WRITTEN APPROVAL OF FAIRCHILD SEMICONDUCTOR CORPORATION. PART DEVICES OR

As used herein:

- Life support device which, (a) are intended for use in safety-critical systems, (b) support or sustain life, or (c) when properly used, are intended to result in a significant injury of the user.

RSL

tonyli@rslgroup.com.cn  
FAX:0755-88262655  
www.rslgroup.com.cn

component of a life support device, the failure of the life support device may result in a significant injury of the user.

PRODUCT STATUS DEFINITION

Definition of Terms

Datasheet Identification		tonyli@rslgroup.com.cn FAX:0755-88262655 www.rslgroup.com.cn
Advance Information		development. Specifications may change in any manner without notice.
Preliminary	First Production	This datasheet contains preliminary data; supplementary data will be published at a later date. Fairchild Semiconductor reserves the right to improve design.
No Identification Number		Fairchild Semiconductor reserves the right to improve design without notice to improve.
Obsolete	Not In Production	This datasheet contains specifications on a product that has been discontinued by Fairchild Semiconductor. The datasheet is printed for

RSL

tonyli@rslgroup.com.cn  
FAX:0755-88262655  
www.rslgroup.com.cn

RSL

tonyli@rslgroup.com.cn  
FAX:0755-88262655

Rev. 131

RSL

tonyli@rslgroup.com.cn  
FAX:0755-88262655  
www.rslgroup.com.cn

RSL

tonyli@rslgroup.com.cn  
FAX:0755-88262655  
www.rslgroup.com.cn

FSFR-Series — Fairchild Power Switch (FPS<sup>™</sup>) for Half-Bridge Resonant Converter