

# UL 817

ISBN 0-7629-0603-0

## Cord Sets and Power-Supply Cords



Underwriters Laboratories Inc. (UL)  
333 Pfingsten Road  
Northbrook, IL 60062-2096

UL Standard for Safety for Cord Sets and Power-Supply Cords, UL 817

Eleventh Edition, Dated March 16, 2001

Revisions: This Standard contains revisions through and including January 14, 2004

### **SUMMARY OF TOPICS**

***This revision is being issued to incorporate the following:***

1. New Padded and Folded-Over Blade Construction Requirements for Attachment Plugs Employed in Power-Supply Cords for Use in Range and Dryer Applications, and
2. Revised Marking Requirements for Detachable Power-Supply Cords.

UL Standards for Safety are developed and maintained in the Standard Generalized Markup Language (SGML). SGML -- an international standard (ISO 8879-1986) -- is a descriptive markup language that describes a document's structure and purpose, rather than its physical appearance on a page. Due to formatting differences resulting from the use of UL's new electronic publishing system, please note that additional pages (on which no requirements have been changed) may be included in revision pages due to relocation of existing text and reformatting of the Standard.

Text that has been changed in any manner is marked with a vertical line in the margin. Changes in requirements are marked with a vertical line in the margin and are followed by an effective date note indicating the date of publication or the date on which the changed requirement becomes effective.

The following table lists the future effective dates with the corresponding item.

Future Effective Dates	References
June 24, 2006	41.1, 67.3, and 67.3.1

The new and/or revised requirements are substantially in accordance with UL's Bulletin(s) on this subject dated March 25, 2003, September 22, 2003, and November 21, 2003. The bulletin(s) is now obsolete and may be discarded.

The revisions dated January 14, 2004 include a reprinted title page (page1) for this Standard.

As indicated on the title page (page 1), this UL Standard for Safety is an American National Standard. Attention is directed to the note on the title page of this Standard outlining the procedures to be followed to retain the approved text of this ANSI/UL Standard.

The master for this Standard at UL's Northbrook Office is the official document insofar as it relates to a UL service and the compliance of a product with respect to the requirements for that product and service, or if there are questions regarding the accuracy of this Standard.

UL's Standards for Safety are copyrighted by UL. Neither a printed copy of a Standard, nor the distribution diskette for a Standard-on-Diskette and the file for the Standard on the distribution diskette should be altered in any way. All of UL's Standards and all copyrights, ownerships, and rights regarding those Standards shall remain the sole and exclusive property of UL.

All rights reserved. No part of this publication may be reproduced, stored in a retrieval system, or transmitted in any form by any means, electronic, mechanical photocopying, recording, or otherwise without prior permission of UL.

Revisions of UL Standards for Safety are issued from time to time. A UL Standard for Safety is current only if it incorporates the most recently adopted revisions.

UL provides this Standard "as is" without warranty of any kind, either expressed or implied, including but not limited to, the implied warranties of merchantability or fitness for any purpose.

In no event will UL be liable for any special, incidental, consequential, indirect or similar damages, including loss of profits, lost savings, loss of data, or any other damages arising out of the use of or the inability to use this Standard, even if UL or an authorized UL representative has been advised of the possibility of such damage. In no event shall UL's liability for any damage ever exceed the price paid for this Standard, regardless of the form of the claim.

UL will attempt to answer support requests concerning electronic versions of its Standards. However, this support service is offered on a reasonable efforts basis only, and UL may not be able to resolve every support request. UL supports the electronic versions of its Standards only if they are used under the conditions and operating systems for which it is intended. UL's support policies may change from time-to-time without notification.

UL reserves the right to change the format, presentation, file types and formats, delivery methods and formats, and the like of both its printed and electronic Standards without prior notice.

Purchasers of the electronic versions of UL's Standards for Safety agree to defend, indemnify, and hold UL harmless from and against any loss, expense, liability, damage, claim, or judgement (including reasonable attorney's fees) resulting from any error or deviation introduced while purchaser is storing an electronic Standard on the purchaser's computer system.

If a single-user version electronic Standard was purchased, one copy of this Standard may be stored on the hard disk of a single personal computer, or on a single LAN file-server or the permanent storage device of a multiple-user computer in such a manner that this Standard may only be accessed by one user at a time and for which there is no possibility of multiple concurrent access.

If a multiple-user version electronic Standard was purchased, one copy of the Standard may be stored on a single LAN file-server, or on the permanent storage device of a multiple-user computer, or on an Intranet server. The number of concurrent users shall not exceed the number of users authorized.

Electronic Standards are intended for on-line use, such as for viewing the requirements of a Standard, conducting a word search, and the like. Only one copy of the Standard may be printed from each single-user version of an electronic Standard. Only one copy of the Standard may be printed for each authorized user of a multiple-user version of an electronic Standard. Because of differences in the computer/software/printer setup used by UL and those of electronic Standards purchasers, the printed copy obtained by a purchaser may not look exactly like the on-line screen view or the printed Standard.

An employee of an organization purchasing a UL Standard can make a copy of the page or pages being viewed for their own fair and/or practical internal use.

The requirements in this Standard are now in effect, except for those paragraphs, sections, tables, figures, and/or other elements of the Standard having future effective dates as indicated in the note following the affected item. The prior text for requirements that have been revised and that have a future effective date are located after the Standard, and are preceded by a "SUPERSEDED REQUIREMENTS" notice.

New product submittals made prior to a specified future effective date will be judged under all of the requirements in this Standard including those requirements with a specified future effective date, unless the applicant specifically requests that the product be judged under the current requirements. However, if the applicant elects this option, it should be noted that compliance with all the requirements in this Standard will be required as a condition of continued Listing and Follow-Up Services after the effective date, and understanding of this should be signified in writing.

Copyright © 2004 Underwriters Laboratories Inc.

This Standard consists of pages dated as shown in the following checklist:

Page	Date
1 .....	January 14, 2004
2-3 .....	June 24, 2003
4-4B .....	January 14, 2004
5-10 .....	March 16, 2001
11-12 .....	June 24, 2003
13-19 .....	March 16, 2001
20-20B .....	June 24, 2003
21-29 .....	March 16, 2001
30 .....	June 24, 2003
31-47 .....	March 16, 2001
48-50D .....	June 24, 2003
51 .....	March 16, 2001
52-53 .....	June 24, 2003
54 .....	March 16, 2001
55 .....	June 24, 2003
56-57 .....	March 16, 2001
58-58B .....	January 14, 2004
59-60 .....	March 16, 2001
61 .....	June 24, 2003
62-66 .....	March 16, 2001
67 .....	June 24, 2003
68 .....	January 14, 2004
69 .....	June 24, 2003
70-84 .....	March 16, 2001
85 .....	June 24, 2003
86-105 .....	March 16, 2001
106 .....	June 24, 2003
107-124 .....	March 16, 2001
SA1-SA14 .....	March 16, 2001
SB1-SB8 .....	March 16, 2001
SR1-SR2 .....	January 14, 2004

No Text on This Page

**MARCH 16, 2001**  
(Title Page Reprinted: January 14, 2004)



**ANSI/UL 817-2003**

1

## **UL 817**

### **Standard for Cord Sets and Power-Supply Cords**

The First edition was titled Standard for Cord Sets.

First Edition – October, 1937  
Second Edition – February, 1948  
Third Edition – May, 1952  
Fourth Edition – December, 1955  
Fifth Edition – June, 1962  
Sixth Edition – February, 1972  
Seventh Edition – December, 1977  
Eighth Edition – May, 1980  
Ninth Edition – December, 1986  
Tenth Edition – January, 1994

#### **Eleventh Edition**

**March 16, 2001**

The most recent designation of UL 817 as an American National Standard (ANSI) occurred on November 5, 2003.

This ANSI/UL Standard for Safety, which consists of the Eleventh Edition with revisions through January 14, 2004, is under continuous maintenance, whereby each revision is ANSI approved upon publication. Comments or proposals for revisions on any part of the Standard may be submitted to UL at any time. Written comments are to be sent to UL-MEL Standards Department, 1285 Walt Whitman Road, Melville, NY 11747.

An effective date included as a note immediately following certain requirements is one established by Underwriters Laboratories Inc.

Revisions of this Standard will be made by issuing revised or additional pages bearing their date of issue. A UL Standard is current only if it incorporates the most recently adopted revisions, all of which are itemized on the transmittal notice that accompanies the latest set of revised requirements.

**ISBN 0-7629-0603-0**

**COPYRIGHT © 1977, 2004 UNDERWRITERS LABORATORIES INC.**

No Text on This Page



**CONTENTS**

<b>FOREWORD</b> .....	10
-----------------------	----

**INTRODUCTION**

1 Scope .....	11
2 Glossary .....	11
3 Components .....	14
4 Units of Measurement .....	14
5 References .....	14

**CONSTRUCTION**

6 General .....	14
7 Configurations .....	16
8 Flexible Cord .....	16
9 Fittings .....	16
10 Connections to Fittings .....	18
11 Identification and Wiring .....	20
12 Treatment of Cord-Conductor Coverings .....	21
13 Strain-Relief Clamps .....	21
14 Fittings Intended to Accommodate Fuses or Other Overcurrent Protective Devices .....	22

**MARKING**

15 General .....	23
------------------	----

**CORD SETS**

16 General .....	24
------------------	----

**GENERAL-USE CORD SETS**

17 General .....	24
18 Switches .....	25
19 Fittings Other Than Switches .....	25
20 Flexible Cord .....	26
21 Overcurrent Protection .....	27
22 Rating .....	27
23 Marking .....	28

**GENERAL-USE CORD SETS – 2-WIRE PARALLEL AND VACUUM CLEANER (SV) FLEXIBLE CORD TYPES**

24 General .....	31
25 Attachment Plug .....	32
25.1 Blades .....	32
25.2 Face .....	32
25.3 Grip .....	34
26 Cord Connector .....	34
26.1 Slots .....	34

26.2	Outlet face	.34
26.3	Recess of contacts	.34
26.4	Depth of cavity	.37
26.5	Outlet separation	.37
26.6	Insertion and withdrawal forces	.37
26.7	Closing of openings	.37
27	Marking	.38

## OUTDOOR-USE CORD SETS

28	General	.40
29	Overcurrent Protection	.40
30	Flexible Cord	.41
31	Attachment Plug	.42
32	Cord Connector	.43
33	Switches	.44
34	Rating	.46
35	Marking	.47

## ADAPTER CORD SETS

36	General	.48
37	Fittings	.50B
38	Flexible Cord	.50C
39	Joints	.50C
40	Rating	.50D
41	Marking	.50D

## RECREATIONAL-VEHICLE CORD SETS

42	General	.50D
43	Fittings	.51

## POWER-SUPPLY CORDS

44	General	.51
45	Switches	.53
46	Use of Shielded Cord	.54
47	Overcurrent Protection	.54

## NONDETACHABLE POWER-SUPPLY CORDS

48	General	.55
49	Fittings	.55
50	Flexible Cord	.55
51	Marking	.55

## POWER-SUPPLY CORDS FOR RANGES AND DRYERS

52	General	.57
52A	Attachment Plug	.58
53	Range and Dryer Power-Supply Cord Kits	.58A
53.1	General	.58A

53.2 Strain relief .....59

No Text on This Page

53.3 Cord push-back relief .....	59
53.4 Terminals .....	59
53.5 User instructions .....	60
53.6 Markings .....	60
53.7 Rating .....	61
<b>OUTDOOR-USE POWER-SUPPLY CORDS</b>	
54 General .....	61
<b>POWER-SUPPLY CORDS FOR RECREATIONAL VEHICLES</b>	
55 General .....	61
56 Flexible Cord .....	61
57 Fittings .....	62
<b>POWER-SUPPLY CORDS FOR MOBILE HOMES</b>	
58 General .....	63
59 Flexible Cord .....	63
60 Fittings .....	63
61 Rating .....	64
<b>NONDETACHABLE POWER-SUPPLY CORDS FOR SPECIAL USE</b>	
62 General .....	64
63 Markings .....	65
<b>DETACHABLE POWER-SUPPLY CORDS</b>	
64 General .....	66
65 Fittings .....	67
66 Flexible Cord .....	68
67 Markings .....	68
<b>DETACHABLE POWER-SUPPLY CORDS HAVING APPLIANCE PLUGS</b>	
68 General .....	69
<b>DETACHABLE POWER-SUPPLY CORDS HAVING FLATIRON PLUGS</b>	
69 General .....	70
<b>DETACHABLE POWER-SUPPLY CORDS FOR APPLIANCES RATED NOT GREATER THAN 50 W</b>	
70 General .....	70
71 Flexible Cord .....	70
72 Appliance Coupler .....	70
73 Rating .....	71

**DETACHABLE POWER-SUPPLY CORDS FOR SPECIAL USE**

74	General	71
75	For Television Receivers	71
76	Replacement-Use with Nonstandard Polarization	71
77	For Vacuum Cleaners and Floor-Finishing Machines	71
78	Detachable Power-Supply Cords For Use In Recreational Vehicles	72
79	Markings	72

**PERFORMANCE**

80	Tests on Female Devices	73
81	Conductor Secureness Test	73
82	Security of Blades Test	74
83	Security of Insulation Test	74
84	Strain Relief Test	75
	84.1 General	75
	84.2 General-purpose fittings	75
	84.3 Investigation of strain relief clamps requiring supplementary mechanical protection	75
	84.4 Joints and general-purpose fittings	76
	84.5 Flatiron and appliance plugs	76
	84.6 Through-cord heating-pad switches	77
85	Strain Relief Test – Range and Dryer Power-Supply Cord Kits	78
86	Push-Back Test for Range and Dryer Power-Supply Cord Kits	80
87	Temperature Test	80
	87.1 General	80
	87.2 Joints	81
88	Dielectric Voltage-Withstand Tests	81
89	Insulation Resistance Test	82
90	Accelerated Aging Tests	82
	90.1 Rubber compounds	82
	90.2 PVC compounds	83
91	Crushing Test	83
92	Impact Resistance Test	83
93	Improper Insertion Test	86
94	Attachment Plug Grip Test	86
95	Blade Pull Test at Elevated Temperature	90
96	Flexing Test – Devices Employing Parallel Cords of Integral or Nonintegral Construction	91
97	Low-Temperature Insertion Test	93
98	Random Drop Test	94
99	Abrupt Pull Test	94
	99.1 Cords employing a grounding conductor	94
	99.2 Two conductor representative devices	96
100	Jacket Retention Test	98
	100.1 General	98
	100.2 Method I – applicable to molded-on assemblies employing attachment plugs and current taps	99
	100.3 Method II – applicable to all molded-on fitting assemblies	99
101	Overcurrent Protective Devices	99
	101.1 General	99
	101.2 Calibration test	100
	101.3 Short-circuit tests for all products with overcurrent protection	100
	101.4 Short-circuit test for fuses	101

101.5	Abnormal test	101
101.6	Water exclusion test for enclosures of outdoor-use products	102
102	Test for Permanence of Cord Tag	102
102.1	General	102
102.2	Test conditions	103
102.3	Test method	104
103	Cord Connector Closure Test	104

## MANUFACTURING AND PRODUCTION TESTS

104	Dielectric Voltage-Withstand Test	104
105	Polarization and Continuity Test	105

## HOSPITAL GRADE ATTACHMENT PLUG PROGRAM

106	General	106
-----	---------	-----

## CONSTRUCTION

107	General	106
-----	---------	-----

## PERFORMANCE

108	General	106
109	Strain Relief Tests	107
109.1	General	107
109.2	Method A – Static pull	107
109.3	Method B – Rotary pull	107
109.4	Method C – Abrupt removal	107
110	Crushing Test	108
111	Impact Resistance Test	108
112	Mechanical Drop Test	108

## MARKING

113	General	111
-----	---------	-----

## TABLES

114	Cord Ampacity and Voltage Ratings	111
115	Cord-Set Ratings	114

## SUPPLEMENT SA - SUPPLEMENT FOR MARINE SHORE POWER CABLE SETS

SA1	Scope	SA1
SA2	Glossary	SA1
SA3	General	SA1

**CONSTRUCTION**

SA4 General .....	SA1
SA5 Corrosion Resistance .....	SA2
SA6 Flexible Cord .....	SA2
SA7 Fittings .....	SA2

**PERFORMANCE**

SA8 Salt Spray Test .....	SA5
SA9 Mechanical Strength Test .....	SA6
SA10 Flexure and Water Spray Test .....	SA6
SA11 Insulation Resistance Test .....	SA11
SA12 Dielectric Voltage-Withstand Test .....	SA11
SA13 Exposure to Low Temperature Test .....	SA11
SA14 Exposure to High Temperature Test .....	SA12
SA15 Ozone Resistance Test .....	SA12
SA16 Exposure to Ultraviolet and Water Test .....	SA12
SA17 Accelerated Air Oven Aging Test .....	SA13

**INSTRUCTIONS**

SA18 Instruction Manual .....	SA13
-------------------------------	------

**SUPPLEMENT SB - FOR SEASONAL-USE CORD SETS****INTRODUCTION**

SB1 Scope .....	SB1
-----------------	-----

**CONSTRUCTION**

SB2 General .....	SB1
SB3 Flexible Cord .....	SB1
SB4 Fittings .....	SB2
SB5 Fittings Intended to Accommodate Fuses or Other Overcurrent Protective Devices .....	SB2
SB6 Overcurrent Protection .....	SB3

**PERFORMANCE**

SB7 General .....	SB3
SB8 Tests on Female Devices .....	SB5
SB9 Conductor Secureness Test .....	SB5
SB10 Strain Relief Test .....	SB5
SB11 Crushing Test .....	SB5
SB11.1 General .....	SB5
SB11.2 Molded-on fittings .....	SB5
SB11.3 All other fittings .....	SB6
SB12 Overcurrent Protective Devices .....	SB6



**RATING**

SB13 General .....SB6

**MARKING**

SB14 General .....SB6

**PACKAGING AND USE INSTRUCTIONS**

SB15 General .....SB8

## FOREWORD

A. This Standard contains basic requirements for products covered by Underwriters Laboratories Inc. (UL) under its Follow-Up Service for this category within the limitations given below and in the Scope section of this Standard. These requirements are based upon sound engineering principles, research, records of tests and field experience, and an appreciation of the problems of manufacture, installation, and use derived from consultation with and information obtained from manufacturers, users, inspection authorities, and others having specialized experience. They are subject to revision as further experience and investigation may show is necessary or desirable.

B. The observance of the requirements of this Standard by a manufacturer is one of the conditions of the continued coverage of the manufacturer's product.

C. A product which complies with the text of this Standard will not necessarily be judged to comply with the Standard if, when examined and tested, it is found to have other features which impair the level of safety contemplated by these requirements.

D. A product employing materials or having forms of construction which conflict with specific requirements of the Standard cannot be judged to comply with the Standard. A product employing materials or having forms of construction not addressed by this Standard may be examined and tested according to the intent of the requirements and, if found to meet the intent of this Standard, may be judged to comply with the Standard.

E. UL, in performing its functions in accordance with its objectives, does not assume or undertake to discharge any responsibility of the manufacturer or any other party. The opinions and findings of UL represent its professional judgment given with due consideration to the necessary limitations of practical operation and state of the art at the time the Standard is processed. UL shall not be responsible to anyone for the use of or reliance upon this Standard by anyone. UL shall not incur any obligation or liability for damages, including consequential damages, arising out of or in connection with the use, interpretation of, or reliance upon this Standard.

F. Many tests required by the Standards of UL are inherently hazardous and adequate safeguards for personnel and property shall be employed in conducting such tests.

## INTRODUCTION

### 1 Scope

1.1 These requirements cover power-supply cords for use as supply connections for appliances in accordance with the National Electrical Code.

1.2 These requirements also cover cord sets for use in extending a branch circuit supply to the power-supply cord of a portable appliance by means of flexible cord in accordance with the National Electrical Code.

1.3 When a specific section makes reference to a general section, and there is a conflict of requirements, the requirements of the specific section shall apply.

1.4 Unless otherwise noted, cord sets and power-supply cords shall be considered to be intended for indoor use.

1.5 *Deleted June 24, 2003*

### Hospital Grade Attachment Plugs

1.6 The requirements in Sections 106 – 113 cover molded-on attachment plugs intended for hospital use in other than hazardous locations in accordance with Article 517 of the National Electrical Code, ANSI/NFPA 70. They are applicable only to nonlocking type devices of conventional configuration (Standard for Wiring Devices – Dimensional Requirements ANSI/NEMA WD 6) rated 15 or 20 A, 125 or 250 V. Attachment plugs shall be of the straight type (longitudinal axis of flexible cord parallel to that of the line blades), molded onto flexible cord.

1.7 Other types such as locking-type configurations or devices for hazardous locations can be investigated based on the Hospital Grade test program in this standard along with any modifications needed to adequately represent the expected use of the device.

## 2 Glossary

2.1 ADAPTER CORD SET – A cord set, without a switch, for use at locations such as construction sites to provide power from a single plug to a maximum of 6 outlets, convert from one contact configuration to another, or both. (See Sections 36 – 41).

2.1 revised June 24, 2003

2.2 ANTENNA POWER-SUPPLY CORD – A nondetachable power-supply cord consisting of a 2-pole, nongrounding-type (15 A, 125 V) attachment plug molded to a 3-conductor parallel-type flexible cord with the third connector terminating inside the body of the attachment plug without being electrically connected to a terminal. (See Sections 48 and 51).

2.3 ATTACHMENT PLUG – A male contact device for the connection of a flexible cord to an outlet device.

2.3 added March 16, 2001

2.4 CORD CONDUCTORS – The total number of conductors in a cord.

2.5 CORD CONNECTOR – A female contact device that is wired on flexible cord.

2.5 added March 16, 2001

2.6 CORD SET – A length of flexible cord assembled:

- a) With an attachment plug or current tap as a line fitting, and a cord connector as a load fitting, and with or without a through-cord switch, or
- b) With a series-connected current tap and a pendant switch.

2.7 CURRENT-CARRYING CONDUCTOR – A cord conductor excluding both the grounding conductor and the neutral conductor which carries only the unbalanced current from the other conductors.

2.8 CURRENT TAP – A male and female contact device that is wired on flexible cord.

2.8 added March 16, 2001

2.9 DETACHABLE POWER-SUPPLY CORD – A length of flexible cord assembled with an attachment plug or current tap as a line fitting and with a single outlet appliance coupler as a load fitting, with or without a through-cord switch. The load fitting is intended to mate with the motor attachment cap of an appliance. (See Sections 64 – 79).

2.10 GENERAL-USE CORD SET – A cord set consisting of the following:

- a) Flexible cord of one of the Types in Table 20.1 and either No. 18, 17, 16, 14, 12, or 10 AWG conductors.
- b) Line and load fittings of the same configuration, rated 15 or 20 A, 125 or 250 V, and of the C1.1, C1.5, C1.6, C1.9, or C1.10 configuration as specified in the Standard for Wiring Device Configurations, UL 1681.
- c) Not be more than three outlets total, unless minimum No. 12 AWG, Type SJ or equivalent flexible cord is employed, in which case the maximum number of outlets is six.
- d) Overcurrent protection, when No. 18 or 17 AWG flexible cord is employed.

- e) With or without a through-cord or pendant switch rated not less than “6 A, 120 V – 3 A, 250 V,” or “10 A, 120 V AC.”
- f) With or without intermediate devices such as fuses, provided that they are not of the automatic resetting type.

2.10 revised March 16, 2001

2.11 GROUNDING CONDUCTOR – The circuit conductor that is intentionally grounded.

2.12 NONDETACHABLE POWER-SUPPLY CORD – A length of flexible cord assembled without a load fitting (appliance coupler) but with an attachment plug or current tap as a line fitting, with or without a through-cord switch for direct connection to an appliance. (See Sections 48– 51).

2.13 OUTDOOR-USE CORD SET – A cord set that is intended to supply power to portable outdoor-use appliances, consisting of the following:

- a) Outdoor-use flexible cord of the types SOW, SOOW, STW, STOW, STOOW, SEW, SEOW, SEOOW, SJOW, SJOOW, SJTW, SJTOW, SJTOOW, SJEW, SJEOW or SJEOOW Type and No. 18, 16, 14, 12, or 10 AWG conductors.
- b) Line and load fittings that are of the same configuration; rated 15 or 20 A, 125 or 250 V of the C1.1, C1.5, C1.6, C2.1, C2.3, C2.4, C2.6, or C2.7 configuration as specified in the Standard for Wiring Device Configurations, UL 1681; resistant to sunlight and mechanical abuse; and exclude moisture from entering the bodies.
- c) Not be more than three outlets, total.
- d) Overcurrent protection, when smaller than 16 AWG flexible cord is employed.
- e) With or without a through-cord or pendant switch rated not less than “6 A, 120 V – 3 A, 250 V,” or “10 A, 120 V AC” and do not permit water to enter the enclosure so as to contact live parts.
- f) With or without intermediate devices such as fuses, provided that they are not of the automatically resetting type and do not permit water to enter the enclosure so as to contact live parts.

2.13 revised March 16, 2001

2.14 OUTDOOR-USE POWER-SUPPLY CORD – A power-supply cord that is intended to be used to supply power to portable outdoor use appliances. (See Section 54).

2.15 OVERCURRENT – Any current in excess of the rated current (ampacity) which may result from an overload or a short circuit condition.

2.16 OVERLOAD – Operation at a current exceeding rated ampacity.

2.17 POWER-SUPPLY CORD FOR MOBILE HOMES – A nondetachable power-supply cord for use with mobile homes. (See Sections 58– 61).

2.18 POWER-SUPPLY CORD FOR RECREATIONAL VEHICLES – A nondetachable power-supply cord for use with recreational vehicles. (See Sections 55 – 57).

2.19 RECREATIONAL-VEHICLE CORD SET – A cord set for use with recreational vehicles. (See Sections 42 and 43).

### 3 Components

3.1 Except as indicated in 3.2, a component of a product covered by this standard shall comply with the requirements for that component.

3.2 A component is not required to comply with a specific requirement that:

- a) Involves a feature or characteristic not required in the application of the component in the product covered by this standard, or
- b) Is superseded by a requirement in this standard.

3.3 A component shall be used in accordance with its rating established for the intended conditions of use.

3.4 Specific components are incomplete in construction features or restricted in performance capabilities. Such components are intended for use only under limited conditions, such as certain temperatures not exceeding specified limits, and shall be used only under those specific conditions.

### 4 Units of Measurement

4.1 Values stated without parentheses are the requirement. Values in parentheses are explanatory or approximate information.

### 5 References

5.1 Any undated reference to a code or standard appearing in the requirements of this standard shall be interpreted as referring to the latest edition of that code or standard.

## CONSTRUCTION

### 6 General

6.1 Each cord set and power-supply cord shall employ materials throughout that are acceptable for the particular use, and shall be made and finished with the degree of uniformity and grade of workmanship practicable in a well-equipped factory.

6.2 A blade used in a 15 or 20 A attachment plug cap shall comply with the Standard for Attachment Plug Blades for Use in Cord Sets and Power-Supply Cords, UL 1659.

*Exception No. 1: A blade which has crimp connections that are also soldered or welded need not comply with the performance requirements in the Standard for Attachment Plug Blades for Use in Cord Sets and Power-Supply Cords, UL 1659.*

*Exception No. 2: A blade which is welded or is made mechanically secure and soldered directly to the conductor connections need not comply with the performance requirements in the Standard for Attachment Plug Blades for Use in Cord Sets and Power-Supply Cords, UL 1659.*

6.3 Each cord set intended for use with a television receiver shall comply with 15.7 and 18.5. Each power-supply cord intended for use with a television receiver shall comply with 44.6, 45.1, 62.2, 63.3, 75.1, and 79.2.

6.4 The length of each cord set or detachable power-supply cord shall be taken as the overall length including the fittings for both line and load connections. See Figure 6.1.

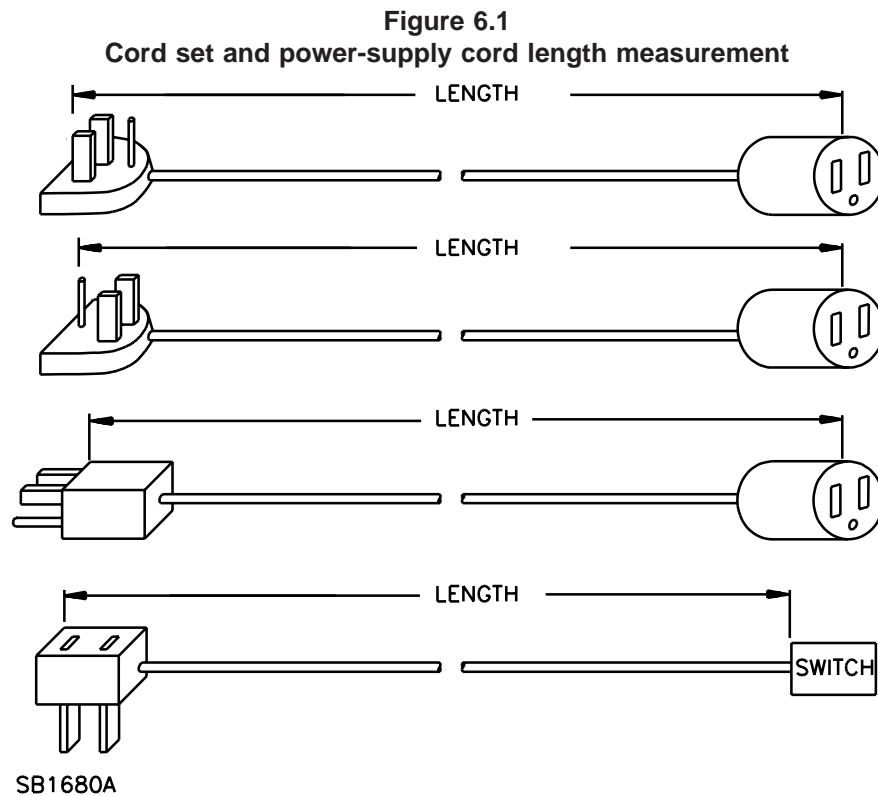

6.5 The length of a nondetachable power-supply cord is to be measured from the end of the line fitting to the point at which the outer covering of the cord is removed.

## 7 Configurations

7.1 The Figures referenced as Sections C1– C3 contain configurations of various attachment plugs and receptacle combinations and are found in the Standard for Wiring Device Configurations, UL 1681.

## 8 Flexible Cord

8.1 A flexible cord shall be continuous from line fitting to load fitting.

*Exception: Flexible cord need not be continuous if the construction involves Switches, Section 18, Joints, Section 39, General, Section 74, or the adapter cord set described in 36.2(b).*

## 9 Fittings

9.1 A fitting that is a part of a cord set or a power-supply cord shall be investigated for use with the type and size of cord used in the assembly.

9.2 A fitting that is part of a cord set, and each part of that portion of a power-supply cord outside the appliance for which it is intended, shall not have a hole, indentation, or projection that could be used for permanent or hang-up mounting of the fitting.

*Exception: A load fitting of a cord set may be provided with a means, such as a hole, hook, indentation, projection, or similar means, molded to the cord connector body, to facilitate temporary positioning during use. A projection shall not be more than 7 inches (178 mm) in length. A hole shall have a minimum inside diameter of 3/8 inch (9.5 mm).*

9.3 Molded-on outlet devices of elastomeric or thermoplastic material and employing contacts of a 2-pole, 2-wire polarized configuration or a standard, 2-pole, 3-wire, grounding configuration, shall prevent the improper insertion of the mating attachment plug, the insertion of a ground pin, or both into any contact opening so that it might contact live parts. Compliance shall be determined by the test described in Improper Insertion Test, Section 93.

9.4 A rigid barrier, molded securely within the body of the connector may be used to meet the requirement in 9.3.

9.5 The face of a nongrounding outlet device of the type illustrated in Figure C1.1 shall obstruct the insertion of a grounding attachment plug of the type illustrated in Figure C1.5. The faces of grounding outlet devices of the types illustrated in Figures C1.6 and C1.10 (rated 125- and 250-V) shall obstruct the insertion of grounding attachment plugs of the type illustrated in Figures C1.10 and C1.6 (rated 250- and 125-V), respectively. The obstructions shall prevent the mating of dissimilarly rated devices by deliberate manual forces and manipulation to deflect the grounding pin to the outside of the face when attempting to insert the line blades.

*Exception: The load fitting of a detachable power-supply cord need not meet the requirements in 9.5.*

9.6 An outlet device having a face that includes the shaded areas indicated in Figure 9.1 is considered to comply with 9.5. The portion of the face located in the shaded areas shall be coplaner with the portion of the face having the slots or shall be recessed from the face not more than 3/32 inch (2.4 mm). The area of the face that provides the obstruction shall not contain any holes, grooves, thin or flexible areas, or other features that defeat the requirement in 9.5. The overall shape of the face or the obstruction is not otherwise limited by this requirement.



**Figure 9.1**  
**Faces of outlet devices showing smallest acceptable obstructions**

Figure 9.1 revised March 16, 2001

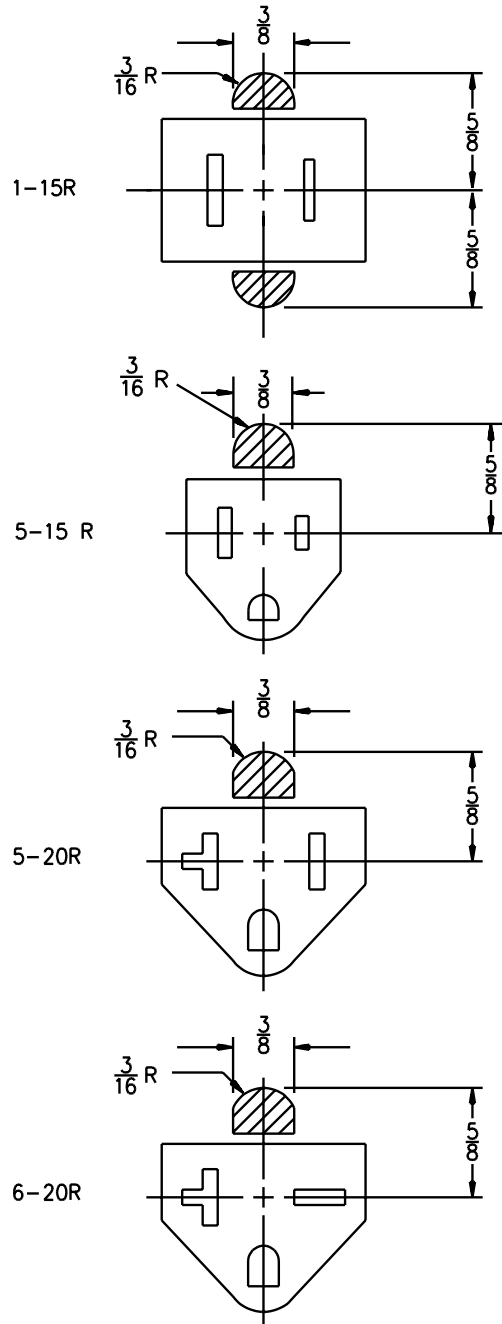

SC1787A

 OBSTRUCTION

Inch	3/16	3/8	5/8
mm	4.8	9.5	15.9

9.7 A nonpolarized, 2-wire, parallel-slot outlet device as shown in Figure C1.1 shall not accommodate an attachment plug having polarized blades to the extent that the wider blade can make electrical contact with either outlet device contact.

9.8 Two-wire fittings for use on Type SJ, SJO, SJOO, SJT, SJTO, SJTOO, SJE, SJEO, SJEOO, SP-3, SPT-3, SPE-3, or heavier flexible cord, other than the load fitting of a detachable power-supply cord, shall have a face size equal to, or larger than, that indicated in Figures 25.3 and 26.1.

9.8 revised March 16, 2001

9.9 The grounding blade or pin of a 15- or 20-A nonlocking type attachment plug shall not contain surface discontinuities that would tend to interfere with insertion into, or withdrawal from a grounding contact of an outlet device. Abrupt surface transitions such as gaps, steps, offsets, detents, holes or sharp chamfers are specifically prohibited in the following areas shown in Figure 9.2:

- a) The shaft, and
- b) The transition zone between the tip and the shaft which is likely to engage the grounding contact during insertion or withdrawal.

9.9 revised March 16, 2001

9.10 A polymeric material used in the fittings of a cord set or power-supply cord shall have a minimum flammability rating of HB, in accordance with the requirements in the Standard for Tests of Flammability of Plastic Materials for Parts in Devices and Appliances, UL 94.

*Exception: A polymeric material that has been subjected to the 12 mm or 3/4 inch end-product flame tests described in the Standard for Polymeric Materials – Use in Electrical Equipment Evaluations, UL 746C, need not have a flame rating.*

## 10 Connections to Fittings

10.1 Each conductor shall be fastened to the terminals of fittings in a manner that:

- a) Keeps strands of any conductor from contacting either uninsulated live parts of opposite polarity or dead metal parts.
- b) Provides mechanical security in accordance with Conductor Secureness Test, Section 81.
- c) Provides adequate ampacity in accordance with Temperature Test, Section 87.
- d) Keeps strands from surfacing in a molded-on fitting.

**Figure 9.2**  
**Grounding pin profiles**

Figure 9.2 added March 16, 2001

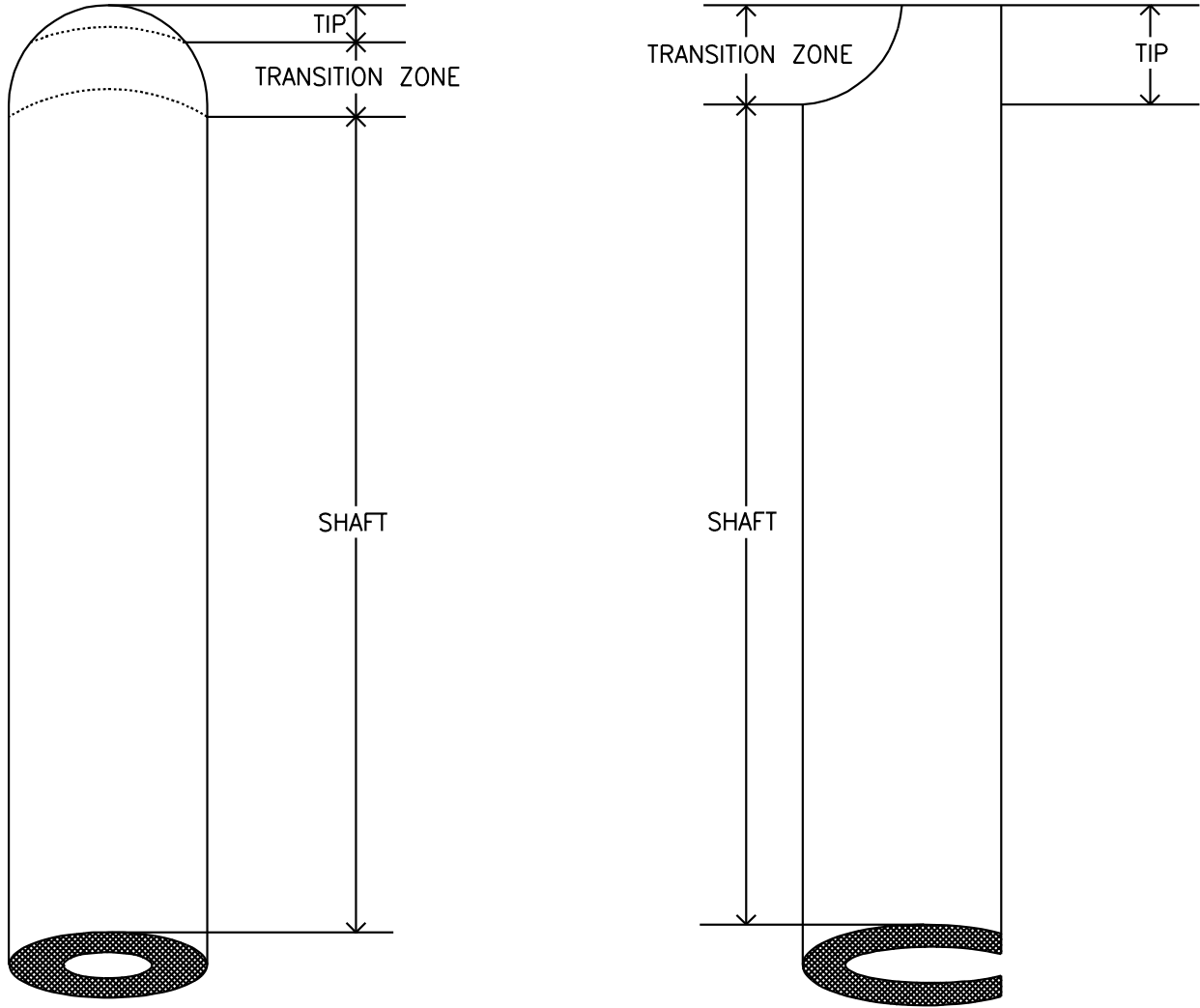

S4166

## 11 Identification and Wiring

11.1 A terminal on a device which is identified for the connection of either a grounded conductor, or a grounding conductor shall be correctly connected to the corresponding identified conductor of the cord.

11.2 If a flexible cord is assembled to a fitting that has any of the configuration contacts as illustrated in Figures C1.1 – C1.38, C2.1 – C2.42, and C3.1 – C3.8, both of the following conditions shall be met:

- a) The conductor in the cord that
  - 1) is finished to show a white or natural grey color,
  - 2) is covered by a white or natural grey braid, or
  - 3) is equivalently identified by
    - i) a white or natural grey separator,
    - ii) a stripe, ridge, or groove on the outside surface of the insulation, or
    - iii) a tin or other white metallic coating on each strand

shall be connected either to the contact designated by the letter W in the illustration (signifying the grounded circuit conductor), or, if there is no contact designated W in the illustration, to a contact designated X, Y, or Z or to any contact that is not designated by a letter.

- b) The conductor in the cord that either:
  - 1) is green with or without one or more yellow stripes, or
  - 2) is covered by a green braid with or without one or more yellow tracers

shall be connected only to the contact designated by the letter G in the illustration (signifying the grounding conductor).

*Exception: The grounded conductor (item a) of a power-supply cord or a single-outlet cord set may have light blue colored or light blue coated insulation if:*

- a) The cord has a jacket that is not integral with the circuit conductor insulation,*
- b) The power-supply cord or cord set is to be factory installed in, or packaged with, an appliance, and*
- c) The shipping package is marked in accordance with 15.5.*

11.2 revised June 24, 2003

11.3 Flexible cord containing a grounding conductor shall not be assembled:

- a) To a 30-A, 3-pole, 3-wire, 125/250-V fitting with a contact configuration illustrated in Figure C1.18, or
- b) To a 50-A, 3-pole, 3-wire, 125/250-V fitting with a contact configuration illustrated in Figure C1.19.

No Text on This Page

## 12 Treatment of Cord-Conductor Coverings

12.1 The insulation, braid, or both on any individual conductor shall be removed only to the extent necessary to make the proper wire connection.

## 13 Strain-Relief Clamps

13.1 A strain-relief clamp shall not be applied on Types SPT-1, NISPT-1, SPT-2, or NISPT-2 cords or on tinsel cords, and shall not affect the thermoplastic jacket adversely when used with Type SVT, SJT, or ST cord.

*Exception No. 1: A strain-relief means can be used that is part of a wiring device that has been previously investigated and found acceptable.*

*Exception No. 2: A strain-relief means can be used that complies with 13.3.*

13.1 revised March 16, 2001

13.2 A metal clamp is acceptable with Type SP-1, NISP-1, SP-2, or NISP-2 cord and other thermoset-insulated cords lighter than Type SJ, only if additional insulation is provided between the clamp and the cord for mechanical protection. See 84.3.1.

13.2 revised March 16, 2001

13.3 Metallic or nonmetallic strain-relief clamps are acceptable for use on Types SPT-1, NISPT-1, SPT-2, NISPT-2, and SVT thermoplastic-insulated cords only with supplementary insulation investigated as described in 84.3.1. For heavier types of thermoplastic-insulated cords, the tests described in 84.3.1 are not required, except where the design of the clamp is judged to be injurious to the cord.

13.3 revised March 16, 2001

13.4 Metal clamps with rigid nonconducting inserts bearing against the cord are acceptable for use with rubber-insulated cord if strain relief is provided and with thermoplastic insulated cord if the investigation described in 84.3.1 is conducted with acceptable results.

13.5 At least one layer of supplementary insulation shall be provided between a flexible cord and a metallic strain-relief clamp.

*Exception: For Type C and heavier general-use cords, and for Types HSJ and HS heater cords, the supplementary insulation can be omitted if the construction of the clamp is such that the cord insulation will not be adversely affected.*

13.6 A fibrous material, such as cotton, varnished cambric, and similar materials, in either tubular or tape form, is acceptable for use as the supplementary insulation mentioned in 13.2, 13.3, and 13.5. A thermoplastic material is not acceptable as such insulation unless it provides protection in the particular application.

## 14 Fittings Intended to Accommodate Fuses or Other Overcurrent Protective Devices

14.1 An acceptable enclosure shall be provided for each overcurrent protective device provided on a cord set or power-supply cord.

14.2 The enclosure of an overcurrent protective device shall be comprised of material that meets the requirements of the Standard for Polymeric Materials – Use in Electrical Equipment Evaluations, UL 746C, and shall have a minimum flammability rating of V-2.

*Exception: Materials of molded-on bodies of attachment plugs or current taps that serve as the enclosure of the overcurrent protective device are acceptable if they operate within their recognized temperature limits during the normal temperature test (with a rated fuse installed) and do not flame or melt to the extent that:*

- a) Live parts are exposed to contact or*
- b) A replaceable fuse cannot be replaced.*

14.3 An overcurrent protective device enclosure shall:

- a) Be of a material having moisture absorptive, flammability, and mechanical strength properties acceptable for the purpose and shall retain these properties when exposed to the maximum temperatures and other conditions of normal use.
- b) Reduce the risk of persons unintentionally contacting uninsulated live parts of the fuse and fuseholder.
- c) Confine the effects of a fuse rupture to the interior of the enclosure.

14.4 With regard to 14.3(a):

- a) Fiber and similar absorptive materials are not considered to have moisture-absorptive properties acceptable for use as the enclosure of a fuse.
- b) Polymeric materials classified as Type V-0, V-1, V-2, or 5V are considered to have acceptable flammability properties for use as the enclosure of a fuse.
- c) Molded phenolic and similar thermosetting polymeric materials are considered to have both moisture-absorptive and flammability properties acceptable for use as a fuse enclosure.

14.5 The construction of a fusible fitting that has male pins or blades, such as an attachment plug or current tap, shall be such that the fuse or fuses are not removable when the pins or blades are energized.

14.6 A fuseholder, attachment plug, or current tap intended to accommodate replaceable fuses shall be plainly and permanently marked "Use only with a fuse rated \_\_\_ amperes, \_\_\_ volts." The values to be inserted in the blanks shall be those appropriate to the product.



14.7 The enclosure of an overcurrent protective device intended for use on an outdoor-use cord set or power-supply cord shall be constructed so that water does not enter a through-cord fuseholder or that portion of an attachment plug or current tap which serves as the enclosure of the protective device (fuse or supplementary protector) so as to contact live parts as determined using the test described in 101.6.1 – 101.6.4.

## MARKING

### 15 General

15.1 Each cord set or power-supply cord shall be marked where it will be plainly visible with the name or trademark of the manufacturer and, where practical, with the catalog number or equivalent.

15.2 If a manufacturer produces or assembles cord sets or power-supply cords at more than one factory, each finished cord set or power-supply cord shall have a distinctive marking, which may be in code, by which it can be identified as the product of a particular factory.

15.3 The manufacturer of a cord set or power-supply cord is considered to be the one who completes the assembly of the cord and fittings.

15.4 Each cord set or power-supply cord that terminates in an attachment plug or fitting having a movable, self-restoring grounding member shall be marked "For hand-held tools and hand-held appliances." The marking shall be on the plug, flag, bracelet, or other acceptable location where it will be readily visible after the power-supply cord has been put into use.

15.5 The smallest unit shipping package containing a cord set or power-supply cord with a grounded conductor having a light blue colored insulation shall be marked to indicate its destination and shall also be marked with the following statement (or equivalent):

This package contains cords having a grounded conductor with a light blue colored insulation instead of the usual white or grey colored insulation.

15.6 Illustrations of outdoor applications, illustration of appliances that are generally used outdoors, and other references to, suggestions of, or both outdoor use shall not appear on any cord set or power-supply cord or on any label, package, wrapper, or other item attached to, associated with, or otherwise giving information on a cord set or power-supply cord, unless the cord set or power-supply cord in question complies with Sections 28 – 35.

15.7 Illustration and other reference or implication of applications involving a cord set (consisting of a series-type current tap and a pendant switch) for use in the remote control of a television receiver, shall not appear on any label, package, wrapper, or be otherwise attached to a cord set unless the switch employed complies with 18.5.

## CORD SETS

### 16 General

16.1 Each cord set shall comply with the general requirements of Sections 6 – 15.

16.2 In a cord set there shall be a conductor attached to each terminal in each fitting, and a terminal in each fitting for each conductor.

16.3 Corresponding terminals of line and load fittings shall be connected to the same conductor of the cord.

16.4 The line and load fittings of a cord set shall both be acceptable for use at identical electrical ratings but may be of different blade/slot configurations (for example, parallel-blade line fitting with locking-type load fitting). Line and load fittings on a cord set shall be for the same purposes with respect to polarity and grounding (for example, a nonpolarized line fitting cannot be employed on a cord set with a polarized load fitting).

16.5 Projections are acceptable on the load fitting of a cord set if there are no holes in the projections and no means (skin easily broken through, and similar means) for making holes.

16.6 A cord set may employ shielded cord provided the shield or drain wire is bonded, along with the grounding conductor, to the grounding contact of both the attachment plug and cord connector.

16.7 A cord that is shielded is identified by the presence of the word "shielded" marked on the outer surface of the cord.

## GENERAL-USE CORD SETS

### 17 General

17.1 General-use cord sets shall comply with the general requirements for cord sets in General, Section 16.

17.2 Each general-use cord set shall consist of general-purpose fittings for line and load connection (see Section 19) assembled to a length of general-use flexible cord (see Table 20.1), and it may include a through-cord or pendant switch or other intermediate devices such as fuses, provided that they are not of the automatically resettable type.

17.3 A general-use cord set may consist of two separate lengths each no greater than 6 ft (1.8 m) of 2-conductor, No. 18 or 16 AWG, Type SP-2, NISP-2, SPT-2, NISPT-2, SPE-2, or NISPE-2 flexible cord connected in parallel to a single 2-wire parallel-blade molded-on attachment plug, with each length terminating in a cord connector. See also 22.2, 22.3, and 23.4.

17.3 revised March 16, 2001

17.4 The length of a general-use cord set less than 6 ft (1.8 m) shall be marked in accordance with 23.11. The marked length of any general-use cord set shall not be less than its measured length as determined by 6.4.

17.5 A general-use cord set may consist of a length of flexible cord having a series-connected or series-multiple current tap at one end and a switching device of other than the dimmer type at the other end to provide remote outlet switching (see 18.7).

17.6 A dimmer cord set consists of the cord set described in 17.5 except that the switching device is that described in 18.6. The series-connected or series-multiple current tap shall be of the polarized type employing both polarized line blades and a polarized slot configuration as shown in Figure C1.1 or C1.5.

## 18 Switches

18.1 A through-cord or pendant switch used as indicated in 17.2 shall be rated not less than "6 A, 120 V – 3 A, 250 V," or "10 A, 120 V AC."

18.2 A switch in a cord set that does not use polarized fittings shall simultaneously open all of the supply conductors.

18.3 A switch in a polarized cord set shall either simultaneously open all of the supply conductors or shall open only the unidentified conductors.

18.4 A switch shall not open a grounding conductor of a cord set.

18.5 A pendant or through-cord switch on a general-use cord set for use with a television receiver shall have a minimum rating of TV-5.

18.6 A dimmer switch for use only with an incandescent lamp load, having a rating of at least 300 W, and marked in accordance with 23.9, shall be used as the pendant switching device on the dimmer cord set described in 17.6.

18.7 A switching device used on the general-use cord set described in 17.5 shall be a pendant switch other than the dimmer type.

## 19 Fittings Other Than Switches

19.1 The fitting for line connection shall be an attachment plug, a nonseparable attachment plug, or a multiple-connected current tap. The load fitting shall be a cord-connector.

*Exception: A series-connected or a series/multiple-connected current tap may be provided on a general-use cord set if the series-connected flexible cord terminates in a pendant switch and the flexible cord is not less than 6 ft (1.8 m) long when measured as described in 6.4.*

19.2 The outlets of a cord connector on a polarized cord set may be controlled by a single-pole pendant switch located on a flexible cord. The unidentified (switched) conductor of the flexible cord is to be continuous from the attachment plug, through the cord connector, to the switch.

19.3 An outlet fitting, such as a cord connector, shall not be connected in the cord between the end fittings of a general-use cord set.

19.4 The total number of outlets in a general-use cord set shall not be more than three.

*Exception: Up to six outlets may be provided in a general-use extension cord set employing No. 12 AWG, Type SJ or equivalent flexible cord.*

19.5 The line and load fittings of a general-use extension cord set having more than three outlets shall both be for use at identical ratings and shall employ the same configuration. The rating shall be 15 A, 125 V (or 250 V, depending on the configuration of the fittings).

19.6 If an assembly-screw hole extends all the way through a cord connector in the form of a table tap, the assembly screw shall be sealed, staked, or held in place by equivalent means.

19.7 Two-pole, 2-wire, 15-A, 125-V, parallel-configuration fittings employed on general-use cord sets shall be polarized.

## 20 Flexible Cord

20.1 The flexible cord of a general-use cord set shall be one of the types listed in Table 20.1.

**Table 20.1**  
**Flexible cord for general-use cord sets<sup>a</sup>**

Table 20.1 revised March 16, 2001

C	SO	SPT-3 <sup>c</sup>
PD	SOO	SPE-2 <sup>c</sup>
HPN <sup>c</sup>	ST	NISPE-2 <sup>c</sup>
SJ	STO	SPE-3 <sup>c</sup>
SJO	STOO	SV
SJOO	SE	SVO
SJT	SEO	SVOO
SJTO	SEOO	SVT
SJTOO	SP-2 <sup>c</sup>	SVTO
SJE	NISP-2 <sup>c</sup>	SVTOO
SJEO	SP-3 <sup>c</sup>	SVE
SJEOO	SPT-2 <sup>b, c</sup>	SVEO
S	NISPT-2 <sup>c</sup>	SVEOO

<sup>a</sup> A cord with any of the following markings is not to be used in a general-use cord set:

- (1) The phrase "For mobile-home use: \_\_\_ amperes." See General, Section 64.
- (2) The phrase "For recreational-vehicle use: \_\_\_ amperes." See General, Section 48 and Rating, Section 61.

<sup>b</sup> Cord constructions that can be demonstrated to be equivalent to integral Type SPT-2 flexible cord may be used in general-use cord sets having a retractile (coiled) cord construction.

<sup>c</sup> These 3-conductor parallel cord types are not acceptable for use on cord sets more than 15 feet (4.5 m) in length.

## 21 Overcurrent Protection

21.1 A general-use cord set (see Sections 17 – 27) employing flexible cord having No. 18 or No. 17 AWG conductors shall be provided with overcurrent protection (short circuit and overload protection) rated equal to or less than the ampacity of the flexible cord.

21.2 The overcurrent protective device shall have a minimum short circuit rating of 1000 A and shall be of the replaceable or manually resettable type. A replaceable fuse shall be of a readily available type to reduce the likelihood of the plug being replaced with one that is unfused. The overcurrent protective device shall not be of the automatic resetting type.

Revised 21.2 effective June 1, 2003

21.3 The overcurrent protective device shall be located in the attachment plug or current tap, or be of a through-cord design located so it is not more than 6 inches (152 mm) from the face of the plug to the rear of the fuseholder.

21.4 Supplementary overcurrent protection is an acceptable method of providing the protection required in 21.1, however, thermal cutouts, thermal relays, and other devices not intended to open short circuits shall not be used.

21.5 The overcurrent protective device shall provide protection for each ungrounded circuit conductor but not for any grounded circuit conductor or grounding conductor.

*Exception: An overcurrent protective device may be used if it opens all circuit conductors – including the grounded circuit conductor(s)– and cannot open the grounded circuit conductor without opening all ungrounded circuit conductors.*

## 22 Rating

22.1 Each general-use cord set shall be rated in amperes, volts, and watts.

22.2 The rating of the general-use cord set described in 17.3 shall not be more than 125 V, 15 A.

22.3 Each individual leg of the general-use cord set described in 17.3 may be rated equal to or less than the ampacity of the cord (see Tables 114.1 – 114.3), provided the total does not exceed 15 A.

22.4 The voltage rating of the cord set shall be determined by the voltage rating of the line-fitting configuration and shall not exceed that of the flexible cord or switch (if provided), whichever is less.

22.5 The cord-set ampere rating is to be determined by the ampere rating of the attachment plug, flexible cord, or switch (if provided), whichever is less.

22.6 When provided with a switch rated for alternating current only the cord-set rating shall also include "AC."

22.7 The wattage rating of a general-use cord set is to be determined by multiplying the ampacity of the cord (see Tables 114.1 – 114.3) or ampere rating of a switch (if provided), whichever is less, by the voltage rating of the load fitting – for example, for No. 18 AWG, Type SPT-2: 10 (amperes) × 125 (volts) = 1250 watts (for a load fitting rated 125 volts); and 10 (amperes) × 250 (volts) = 2500 watts (for a load fitting rated 250 volts).

## 23 Marking

23.1 Each general-use cord set is to be marked with its electrical rating.

23.2 The electrical rating shall be printed on one of the marker devices described in 23.6.

23.3 Each general-use cord set employing Type SP-2, SP-3, SPT-2, SPT-3, SPE-2, or SPE-3 flexible cord, employing No. 30 AWG stranded conductors, shall be permanently and legibly marked according to 23.6 "FOR USE ONLY WHERE NOT SUBJECT TO FREQUENT FLEXING," or the equivalent.

23.4 The general-use cord set described in 17.3, and rated in accordance with the requirements in 22.2 and 22.3, shall be marked with the rating printed on one of the marker devices described in 23.6.

23.5 The wattage of the general-use cord set described in 17.3 is to be determined as described in 22.7.

23.6 The electrical rating of a general-use cord set may be on one of the following:

- a) Printed on a doughnut-, flat-, or bracelet-type label.
- b) Printed on a tag of tough paper, cloth, or the equivalent (of any color) having a hole large enough to accommodate the cord, and not resembling the shapes described in item c. The tag is not to be slit from the edge of the hole to the edge of the tag. The cord is to be passed through the hole in the tag prior to assembly of the end fittings on the cord set.
- c) Printed in a contrasting color on a background of a solid color other than blue, green, or yellow on one of the following:
  - 1) A ring-shaped (doughnut) tag of tough paper, cloth, or the equivalent having a hole large enough to accommodate the cord. The tag is not to be slit from the edge of the hole to the edge of the tag. The cord is to be passed through the hole in the tag prior to the assembly of the end fittings of the cord set.
  - 2) A flag-type tag with an adhesive back. The tag is to be wrapped around and adhere to the cord, and the ends of the tag are to adhere to each other and project as a flag.
  - 3) A bracelet wrapped around and affixed to the cord with an adhesive.

23.7 A nonrewireable (molded-on or factory-assembled) load fitting may be marked with a current rating only if the ampacity of the flexible cord and any through-cord switch is equal to or higher than that of the fitting configuration.

23.8 A nonrewireable (molded-on or factory-assembled) line fitting may be marked with a current rating only if all the following conditions are met:

- a) The ampacity of the flexible cord and any through-cord switch is equal to or higher than that of the fitting configuration,
- b) The load fitting is marked with its current rating,
- c) The electrical current rating of both fittings are identical and are the same as that specified for the particular configuration involved, and
- d) The marked rating is the same as that of the fitting configuration.

23.9 Except as noted in 23.10, the dimmer switch described in 18.6 shall be indelibly marked where plainly visible on or directly adjacent to the load fitting with the following marking or its equivalent: "CAUTION – To reduce the risk of fire, use with \_\_\_ watt maximum incandescent lamp load only." The word "CAUTION" shall be in letters not less than 3/32 inch (2.4 mm) high. The maximum wattage inserted in the blank shall not exceed the rated wattage of the dimmer switch.

23.10 The marking required in 23.9 may be provided on a permanent tag attached to the dimmer switch, the current tap, or the flexible cord. The tag shall be attached in a manner that it cannot be easily removed. The tag shall have the added marking in letters not less than 3/32 inch (2.4 mm) high "Do not remove this tag."

23.11 The length of a general-use extension cord set that is shorter than 6 ft (1.8 m) shall be plainly and permanently marked on the individual wrapper, tag, or equivalent attached to the cord set.

23.12 General-use cord sets having 2-pole, 2-wire fittings of the 15-A, 125-V polarized configuration shall be marked with the following information:

This is a POLARIZED cord set.

It has a polarized plug (one blade is wider than the other) and a polarized outlet (one slot is longer than the other).

The polarized plug is not intended to be mated with nonpolarized outlets (having both slots the same size).

A polarized outlet is intended to mate with a polarized plug in only one way (the longer slot with the wider blade).

23.13 The markings required in 23.12 shall be legible, distinct and prominently displayed on (1) the outer surface of the smallest unit package or (2) an included stuffer sheet or tag (or its equivalent) in which case the word POLARIZED shall appear on the outer surface of the smallest unit package. The markings shall comply with the following:

a) The words "POLARIZED" and "CAUTION" in the first element of each marking or where they appear separately are to be of boldface capital letters a minimum of 9/64 inch (3.6 mm) high and the remaining words are to be a minimum of 1/16 inch (1.6 mm) high.

b) The color of the letters shall contrast with a solid color background.

23.14 A general-use cord set that employs fittings of the C1.1, C1.5, C1.6, C1.9, or C1.10 configuration as specified in the Standard for Wiring Device Configurations, UL 1681, shall be provided with a tag as shown in Figure 23.1. The tag shall be tear-resistant and permanently affixed to the cord set. The leading edge of the tag shall be located within 18 inches (46 cm) of the point where the cord enters the body of the attachment plug. The marking itself shall be indelible. See Test for Permanence of Cord Tag, Section 102.

Revised 23.14 effective March 16, 2003

23.15 The marking mentioned in 23.14 is acceptable if:

a) All letters shown as capitals, in boldface, or both in Figure 23.1 are as such on the tag.

Figure 23.1  
Marking tag

Figure 23.1 revised June 24, 2003



## DANGER: ELECTRICAL CORDS CAN BE HAZARDOUS

Misuse Can Result In FIRE or DEATH  
by ELECTRICAL SHOCK  
Please Read BOTH SIDES Carefully and  
Follow All Directions.

### BEFORE USE

- A Cord Set Not Marked For Outdoor Use Is To Be Used Indoors Only. See Label For Outdoor Marking.
- Inspect Thoroughly Before Each Use.  
**DO NOT USE IF DAMAGED.**
- Look For the **NUMBER OF WATTS** On Appliances To Be Plugged Into Cord.
- See **PRODUCT** or **LABEL** Markings for **SPECIFIC WATTAGE.**
- Do Not Plug More Than the **SPECIFIED NUMBER OF WATTS** Into This Cord.
- Do Not Run Through Doorways, Holes in Ceilings, Walls or Floors.
- Make sure Appliance is OFF Before Connecting Cord to Outlet.
- **FULLY INSERT** Plug Into Outlet.
- Do Not Remove, Bend or Modify Any Metal Prongs or Pins of Cord.
- Do Not Use Excessive Force to Make Connections.
- Do Not Connect  a Three-Prong Plug to a Two-Hole Cord.



**THIS IS A POLARIZED CORD**



## DANGER: ELECTRICAL CORDS CAN BE HAZARDOUS

Misuse Can Result In FIRE or DEATH  
by ELECTRICAL SHOCK  
Please Read BOTH SIDES Carefully and  
Follow All Directions.

### DURING USE

- Keep Away From Water.
- **DO NOT USE WHEN WET.** 
- Keep Children and Pets Away From Cord.
- Do Not Plug One Extension Cord Into Another
- **AVOID OVERHEATING.** Uncoil Cord and Do Not Cover It With Any Material.
- Do Not Drive, Drag or Place Objects Over Cord.
- Do Not Walk on Cord. 

### AFTER USE

- **GRASP PLUG** to Remove From Outlet
- Always Store Cord **INDOORS.**
- Always Unplug When Not In Use.
- Do Not Unplug By  Pulling On Cord.

**DO NOT REMOVE THIS TAG**



- b) The words "**DANGER: ELECTRICAL CORDS CAN BE HAZARDOUS**" are a minimum of 9/64 inch (3.6 mm) high, and the remaining words are a minimum of 1/16 inch (1.6 mm) high.
- c) The lettering and illustrations are black with a solid white background.
- d) The markings are preceded by a solid red octagon, oriented so as to resemble a "stop" sign, a minimum of 5/16 inch (7.9 mm) across.
- e) The required illustrations are located within red circles a minimum of 7/16 inch (11.1 mm) in diameter crossed by a red diagonal line.

23.16 The marking in 23.14 shall be provided in either of the following forms:

- a) A hang-type tag having a hole to permit securement to the cord by a plastic strap or equivalent. The strap shall not be removable without cutting.
- b) A flag-type tag with an adhesive back. The tag is to be wrapped around and adhere to the cord. The ends of the tag are to adhere to each other and project as a flag.

## **GENERAL-USE CORD SETS – 2-WIRE PARALLEL AND VACUUM CLEANER (SV) FLEXIBLE CORD TYPES**

### **24 General**

24.1 These requirements are intended to cover 2-wire general-use cord sets with polarized parallel-blade and parallel-slot fittings rated 15 A, 125 V and employing 2-conductor

No. 18 AWG, Types HPN, SP-2, NISP-2, SPT-2, NISPT-2, SPE-2, NISPE-2, SV, SVO, SVOO, SVT, SVTO, SVTOO, SVE, SVEO, SVEOO,

No. 17 AWG, Types HPN, SV, SVO, SVOO, SVT, SVTO, SVTOO, SVE, SVEO, SVEOO,

No. 16 AWG, Types HPN, SP-2, NISP-2, SPT-2, NISPT-2, SPE-2, flexible cord.

24.1 revised March 16, 2001

24.2 These requirements are supplemental to requirements applicable to general-use cord sets (Sections 17 – 23).

24.3 The attachment plug requirements in Attachment Plug, Section 25 and the cord connector requirements in Cord Connectors, Section 26 are also applicable to current taps employed on the cord sets mentioned in 24.1.

## 25 Attachment Plug

### 25.1 Blades

25.1.1 The blades shall be located as shown in Figure 25.1 and parallel to one another (compliance shall be determined by full insertion, as described in 26.6.1, into the cord connector described in 26.1.1) and shall comply with the dimensional requirements in the Standard for Attachment Plug Blades for Use in Cord Sets and Power-Supply Cords, UL 1659.

**Figure 25.1**  
Blade construction of 2-pole, 2-wire attachment plug  
(15 A, 125 V)

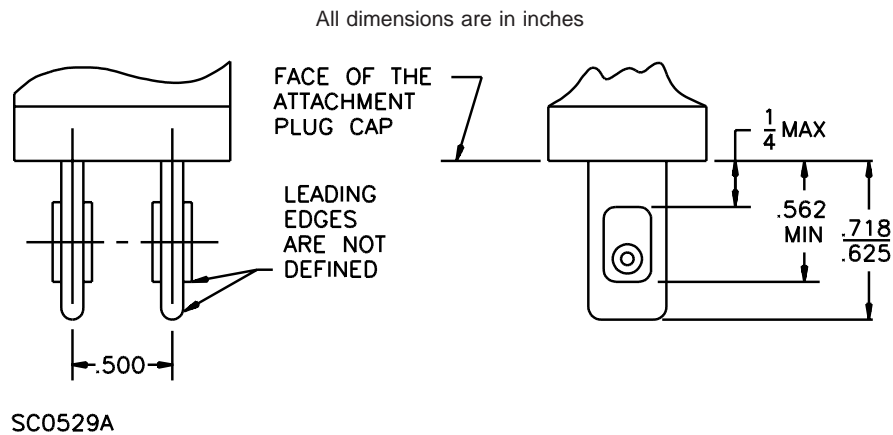

inch	0.250	0.500	0.562	0.718
mm	6.35	12.7	14.3	18.2
				15.9

### 25.2 Face

25.2.1 The face of a 2-wire parallel-blade attachment plug shall be in a plane perpendicular to the major axis of the blades (compliance shall be determined by full insertion, as described in 26.6.1, into the cord connector described in 26.1.1) and shall be  $1.000 \pm 0.025$  by  $0.750$  plus  $0.000$  minus  $0.020$  inch ( $25.40 \pm 0.64$  by  $19.05$  plus  $0.00$  minus  $0.51$  mm) with the blades centered, with a maximum  $7/32$  inch ( $5.6$  mm) radius at the corners. The 1-inch ( $25.4$  mm) dimension shall be perpendicular to the width of the blades. See Figure 25.2.

*Exception: A larger face size may be provided on a shallow-bodied right-angle plug.*

Figure 25.2  
Male fitting face dimensions

All dimensions are in inches

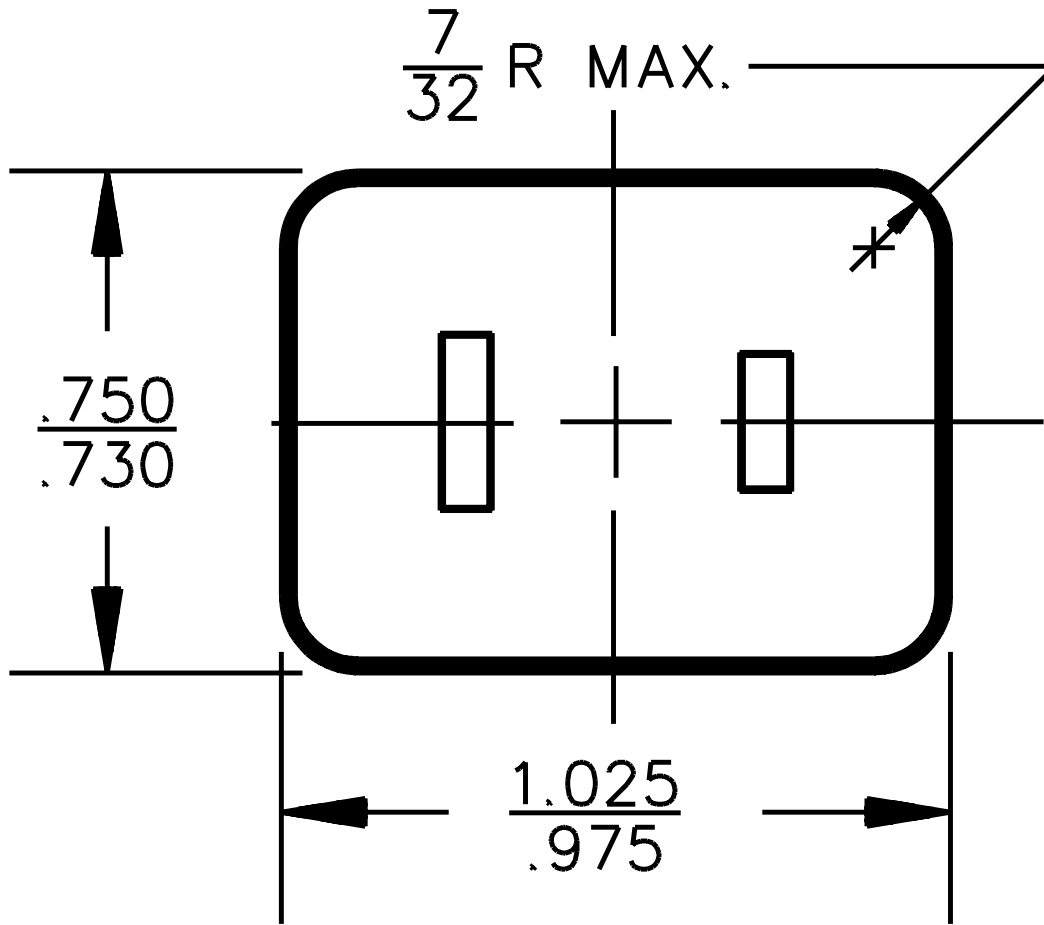

SA0527A

BLADES  
CENTERED

Inch	$\frac{7}{32}$	$\frac{0.750}{0.730}$	$\frac{1.025}{0.975}$
mm	5.6	$\frac{19.05}{18.54}$	$\frac{26.04}{24.77}$

### 25.3 Grip

25.3.1 The body of a 2-wire parallel-blade attachment plug shall be shaped so that it is not likely to be grasped at the face periphery but rather invites gripping at a section formed for such a purpose. The gripping area shall extend over a distance of at least  $11/16$  inch (17.5 mm) located between two higher sections. The section at the rear shall provide a sharply defined projection at least  $3/32$  inch (2.4 mm) high with a base of at least 0.062 inch (1.57 mm) and an overall width of at least  $1/4$  inch (6.4 mm). See Figure 25.3. In place of the gripping area, a finger grip in the form of a substantial closed loop capable of accommodating one or more fingers may be provided. Other gripping surfaces are acceptable provided they meet the Attachment Plug Grip Test, Section 94. A grip or gripping surface may need to be additionally investigated for the ability to withstand the conditions of normal use such as flexing, mechanical strength, and similar conditions.

## 26 Cord Connector

### 26.1 Slots

26.1.1 The parallel slots in the face of a cord connector shall be spaced  $0.500 \pm 0.005$  inch ( $12.7 \pm 0.13$  mm) on centers. Unpolarized slots shall be 0.075 inch (1.9 mm) minimum, 0.095 inch (2.4 mm) maximum in width and 0.265 inch (6.7 mm) minimum, 0.285 inch (7.2 mm) maximum in length. Polarized slots shall be 0.075 inch (1.9 mm) minimum, 0.095 inch (2.4 mm) maximum in width and 0.330 inch (8.4 mm) minimum, 0.350 inch (8.9 mm) maximum in length.

### 26.2 Outlet face

26.2.1 The perimeter of the outlet face shall at least encompass a total area consisting of a 1-by- $3/4$  inch (25.4-by-19.1 mm) rectangle with a  $7/32$  inch (5.6 mm) maximum radius at corners and expanded by a  $3/16$  inch (4.8 mm) radius half-circle projection from the center of each of the 1 inch (25.4 mm) sides. The parallel-outlet configuration slots shall be located as a pair in the center of the total covered area with the slots parallel to the  $3/4$  inch (19.1 mm) sides of the rectangle. Refer to Figure 26.1.

### 26.3 Recess of contacts

26.3.1 The female contacts of a 2-wire parallel-slot cord connector shall be recessed at least  $1/4$  inch (6.4 mm) from the face of the fitting.

**Figure 25.3**  
**Attachment plug finger grip and blade guards**

All dimensions are in inches

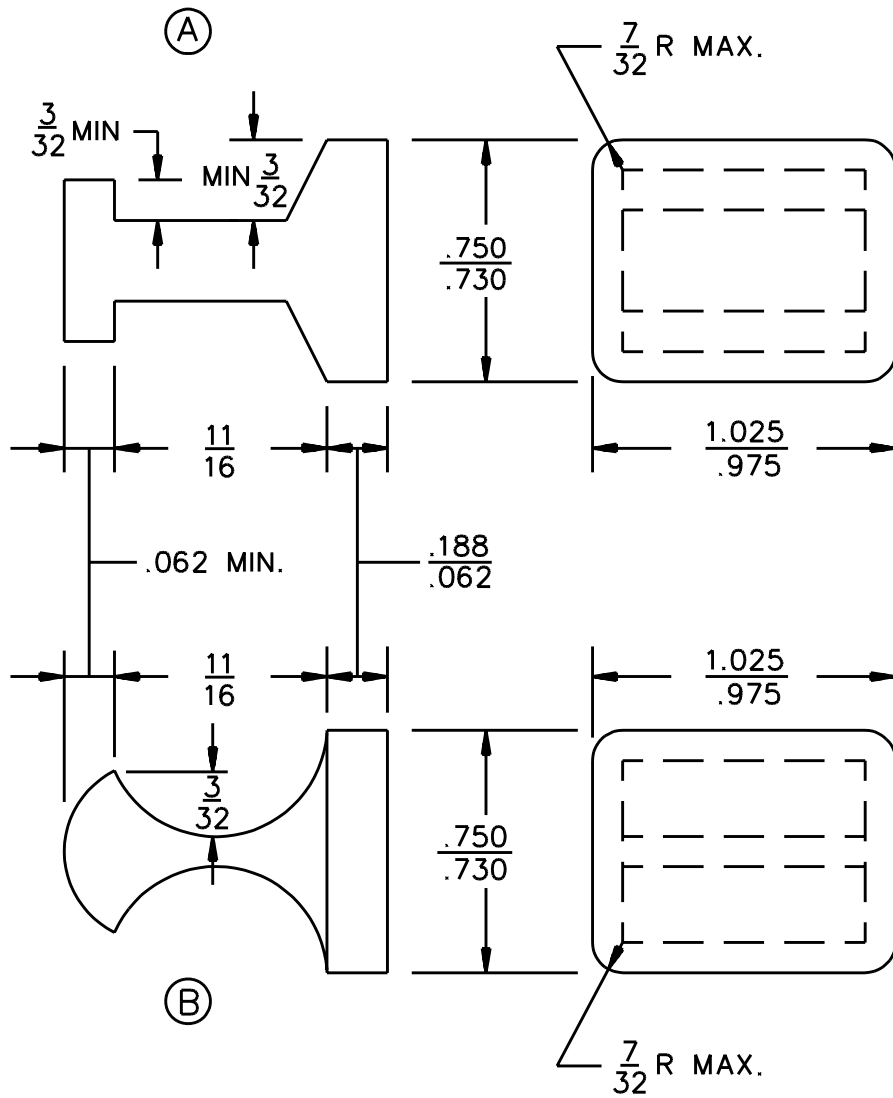

$\frac{3}{32}$  MIN—MATERIAL OVER LIVE PARTS

SB0528A

			<u>0.188</u>			<u>0.750</u>	<u>1.025</u>
Inch	0.062	$\frac{3}{32}$	0.062	$\frac{7}{32}$	$\frac{11}{16}$	0.730	0.975
mm	1.57	2.4	4.78	5.6	17.5	19.05	26.04
			<u>1.57</u>			<u>18.54</u>	<u>24.77</u>

Figure 26.1  
Female fitting face dimensions

All dimensions are in inches

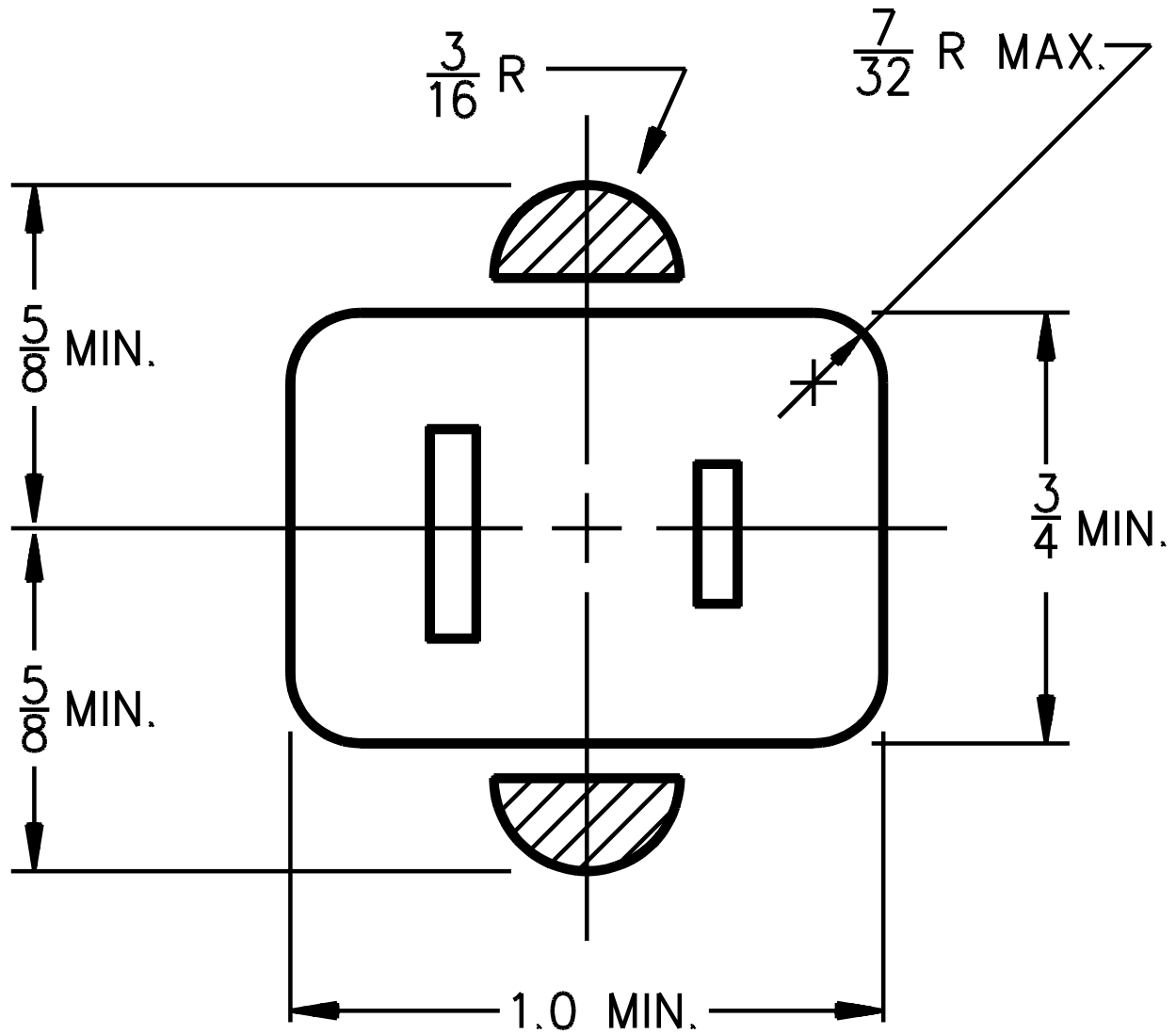

CONTACT  
SLOTS CENTERED

SA1265

Inch	$\frac{3}{16}$	$\frac{7}{32}$	$\frac{5}{8}$	$\frac{3}{4}$	1
mm	4.8	5.6	15.9	19.0	25.4

## 26.4 Depth of cavity

26.4.1 A cord connector shall accommodate a parallel-blade attachment plug without any blade exposure between the faces of the fittings. The determination shall be made by insertion of a depth gauge in each slot. The depth gauge shall have a cross section of 0.260 by 0.065 inch (6.6 by 1.7 mm) for checking nonpolarized slots and 0.322 by 0.065 inch (8.2 by 1.7 mm) for checking polarized slots. Each gauge shall have a scribed mark located 0.718 inch (18.2 mm) from the end of the gauge inserted in the slot. A force of not more than 15 lbf (67 N or 6.8 kgf) may be used to determine if the gauge is fully inserted into the slot; after full insertion, the scribed mark shall not be located outside the plane of the face of the cord connector.

## 26.5 Outlet separation

26.5.1 When two or more parallel-slot outlets are on the same surface of a cord connector they shall be spaced apart so that adjacent plugs with the dimensions in Figure 25.2 can be fully inserted with no exposed blades.

## 26.6 Insertion and withdrawal forces

26.6.1 The force needed for the initial insertion of an attachment plug into a cord connector shall not exceed 20 lbf (89 N or 9.1 kgf). The pull to withdraw the plug after the first insertion and subsequent insertions shall not exceed 15 lbf (67 N or 6.8 kgf). The force needed for subsequent insertions of the attachment plug shall not exceed 15 lbf (67 N or 6.8 kgf). After application of the insertion force a gap of not more than 0.010 inch (0.25 mm) shall exist between the face of the attachment plug and the face of the cord connector. After 10 conditioning cycles of insertion and withdrawal of the attachment plug, a pull of 3 lbf (13 N or 1.4 kgf) in a direction perpendicular to the face of the cord connector and tending to withdraw the plug is to be applied for 1 minute. The results are unacceptable if there is any displacement of the plug.

## 26.7 Closing of openings

26.7.1 If a cord connector employed on a cord set has more than one outlet, the contact openings of all, or all but one, of the outlets shall be reliably and effectively closed.

26.7.2 The closing means shall be formed of insulating material and shall have physical properties to withstand the rigors of use and reasonably foreseeable abuse.

26.7.3 The closing means mentioned in 26.7.2:

- a) Shall, when the closing means is positioned as intended, obstruct a straight steel wire 0.010 inch (0.25 mm) in diameter (No. 30 AWG) from touching any female contact.
- b) Shall in no case be removable from the cord set. A closure that is removable from the outlet shall remain within 6 inches (152.4 mm) of the cord connector when not in use. See Cord Connector Closure Test, Section 103.
- c) Shall be capable of displacement from (complete removal when appropriate) and return (insertion when appropriate) to the outlet in the intended manner without breakage or damage both before and after the cord connector and closing means have been conditioned for 7 hours at  $70.0 \pm 1.0^{\circ}\text{C}$  ( $158.0 \pm 1.8^{\circ}\text{F}$ ) in a full-draft circulating-air oven. Each of three representative cord connectors is to be conditioned. When the closing means is removable from the outlet, the conditioning shall be conducted with the closing means positioned in the cord connector; three

additional representative closing means not positioned in the outlet are also to be subjected to the conditioning. The displacement and return operation after conditioning, described in (d), shall be conducted after the parts have cooled to room temperature.

d) Shall not impair the performance of the cord connector. The cord connector is to be examined after three simulated cycles of use to determine whether or not damage has occurred. Each cycle of use shall consist of the displacement and return of the closing means in the intended manner.

e) Shall not serve as a tab or handle used to open another closing means on the cord connector.

Revised 26.7.3 effective June 1, 2002

26.7.4 If the closing means mentioned in 26.7.3 consists of an insulating closure, it shall not be provided with handles, loops, knobs, or similar hardware that might facilitate removal. A straight pull of less than 1 lbf (4.4 N or .454 kgf) perpendicular to the face of the outlet shall not remove the closure from the outlet.

## 27 Marking

27.1 These marking requirements are intended to cover 2-wire general-use cord sets as described in 24.1.

27.2 A 2-wire general-use cord set as described in 24.1 shall comply with 23.14 – 23.16.

27.3 In addition to the marking required by 27.2, a 2-wire general-use cord set shall be marked as indicated below. The blank shall be filled in with the appropriate wattage.

<p>ATTENTION: INSTRUCTIONS FOR PROPER USE</p> <p>COVER UNUSED OUTLETS FULLY EXTEND BEFORE USING RATED 125-VOLTS USE WITHIN THE ELECTRICAL RATING MARKED ON THE CORD SET</p> <p>DO NOT PLUG MORE THAN TOTAL OF _____ WATTS IN THIS CORD SET</p> <p>If watts not marked on appliance, multiply ampere rating (on nameplate) by 125 to determine equivalent watts. Add determined watts for each plugged-in appliance or lamp (sum of watts on bulbs) to find total watts being used.</p>
--

*Exception No. 1: A single outlet cord set longer than 20 feet (6.1 m) need not comply with this requirement.*

*Exception No. 2: If the cord set employs only one outlet, the statement "Add determined watts for each plugged-in appliance or lamp (sum of watts on bulbs) to find total watts being used." may be omitted.*

*Exception No. 3: "RE-COVER UNUSED OUTLETS" may be used in place of "COVER UNUSED OUTLETS."*

*Exception No. 4: If the cord set employs only one outlet, or the outlets are self-closing, "COVER UNUSED OUTLETS" or "RE-COVER UNUSED OUTLETS" may be omitted.*



*Exception No. 5: If a cord set is so packaged that it is not likely to be used while coiled, "FULLY EXTEND BEFORE USING" may be omitted.*

27.4 The marking in 27.3 shall be on one of the following:

- a) The surface of the load fitting,
- b) An individual wrapper, or
- c) A tag attached to the cord set.

The tag or wrapper may be removable from the cord set. Each element in the marking is to be an obvious individual item. The marking itself shall be either:

- d) Indelible on the wrapper or tag or
- e) Integral with the surface of the load fitting. If the marking is included on the tag in Figure 23.1, it shall comply with 23.14– 23.16.

27.5 All of the elements of the marking required by 27.3 need not be provided on a single surface. These elements may appear at separate locations. "DO NOT PLUG MORE THAN TOTAL OF \_\_\_\_\_ WATTS IN THIS CORD SET" and the explanation of wattage determination shall be provided entirely on a single surface. If any of the individual elements appear at different locations, then "ATTENTION: INSTRUCTIONS FOR PROPER USE" shall be provided at each location.

27.6 The marking mentioned in 27.3 shall be legible to the user during the procedures usually followed in preparation for use (unwrapping, unhanking, and so forth).

27.7 The marking mentioned in 27.3 is to be considered acceptable if:

- a) All letters are boldface capital letters except for the explanation of wattage determination.
- b) The letters are a minimum of 1/16 inch (1.6 mm) high.
- c) The letters whether indelible, embossed, or indented contrast with a solid-color background surrounded by a contrasting-color border at least 1/8 inch (3.2 mm) wide. The letters may be the same color as the border.

*Exception: The 1/8 inch (3.2 mm) border of contrasting color need not be provided if the required marking remains sufficiently distinctive to draw the reader's immediate attention to each element.*

## OUTDOOR-USE CORD SETS

### 28 General

28.1 Outdoor-use cord sets shall meet the general requirements of General, Section 16.

### 29 Overcurrent Protection

29.1 Outdoor-use sets employing flexible cord having No. 18 or No. 17 AWG conductors shall be provided with integral overcurrent protection and shall comply with applicable requirements in Fittings Intended to Accommodate Fuses or Other Overcurrent Protective Devices, Section 14; Overcurrent Protection, Section 21; and Overcurrent Protective Devices, Section 101.

29.2 An outdoor-use cord set is intended to be used in conjunction with portable electric equipment that is intended for use outdoors. The cord set is intended for use outdoors only while the portable equipment is in operation. It is intended to be stored indoors where it is not exposed to sunlight, weather, or both while not in use. It can also be used indoors.

29.3 An outdoor-use cord set shall be either of the nongrounding type containing two circuit conductors or of the grounding type containing two or three circuit conductors.

29.4 An outdoor-use cord set shall consist of a length of flexible cord that complies with Flexible Cord, Section 30 and is attached to an attachment plug and cord connector each having the same contact configuration. The attachment plug shall comply with Attachment Plug, Section 31. The cord connector shall comply with Cord Connector, Section 32.

29.5 An outdoor-use cord set may incorporate a through-cord or pendant switch provided the switch enclosure is suitable for outdoor-use as determined by the requirements in Switches, Section 33.

29.6 An outlet fitting, such as a cord connector, shall not be connected between the end fittings of an outdoor-use cord set.

*Exception: An adapter cord set described in 36.2(b) is able to be provided with outlet fittings connected between the end fittings.*

29.7 An outdoor-use cord set shall have a minimum length of 6 ft (1.8 m).

29.8 An outdoor-use cord set with a 3-outlet cord connector (see 32.3) shall have a maximum length of 100 ft (30.5 m).

### 30 Flexible Cord

30.1 The flexible cord shall be Type SOW, SOOW, STW, STOW, STOOW, SEW, SEOW, SEOOW, SJOW, SJOOW, SJTW, SJTOW, SJTOOW, SJEW, SJEOW, or SJEOWW. All cord conductors shall be of the same size and shall not be smaller than indicated in Table 30.1. In addition, the flexible cord shall comply with one of the following requirements:

- a) A 2-wire type of outdoor-use cord set shall contain two insulated circuit conductors.
- b) The cord of a grounding-type outdoor-use cord set shall contain two or three insulated circuit conductors and one insulated grounding conductor. The insulation on the grounding conductor in the cord shall be finished to show a green color with or without one or more yellow stripes.

30.1 revised March 16, 2001

30.2 Deleted March 16, 2001

30.3 Flexible cord marked with the word "outdoor" is only for use in cord sets that are for outdoor use.

**Table 30.1**  
**Smallest acceptable conductor size with respect to fittings used on outdoor-use cord sets and outdoor-use power-supply cords<sup>e</sup>**

Table 30.1 revised March 16, 2001

Ampere rating of fittings	Number of cord conductors	Number of current-carrying conductors in cord <sup>a</sup>	Grounding required	Maximum number of outlets in cord connector when provided	Smallest acceptable conductor size (AWG)		Ampacity rating of cord (Amperes)
					6 – 50 <sup>b</sup> ft (1.8 – 15.2 Meters)	Over 50 ft (Over 15.2 Meters)	
15	2	2	No	1	–	18	7
	3 or 4	2	Yes	1	–	18	7
	4	3	Yes	1	–	18	7
	2	2	No	1	18	16	10
	3 or 4	2	Yes	1	18	16	10
	4	3	Yes	1	18	16	7 (10) <sup>c</sup>
	2	2	No	1	16	14	13
	3 or 4	2	Yes	3	16	14 <sup>d</sup>	13
	4	3	Yes	1	16	14	10 (13) <sup>c</sup>
	2	2	No	1	14	12	15
	3 or 4	2	Yes	1	14	12	15
	4	3	Yes	1	14	12	15
20	3	2	Yes	3	14	12 <sup>d</sup>	15
	3 or 4	2	Yes	1	12	10	20
30	4	3	Yes	1	12	10	20
	3 or 4	2	Yes	1	10	8	30

Table 30.1 Continued on Next Page

Table 30.1 Continued

Ampere rating of fittings	Number of cord conductors	Number of current-carrying conductors in cord <sup>a</sup>	Grounding required	Maximum number of outlets in cord connector when provided	Smallest acceptable conductor size (AWG)		Ampacity rating of cord (Amperes)
					6 – 50 <sup>b</sup> ft (1.8 – 15.2 Meters)	Over 50 ft (Over 15.2 Meters)	
	4	2	Yes	1	10	8	30
50	3 or 4	2	Yes	1	6	4	50
	4	3	Yes	1	4	2	50
60	4	2	Yes	1	4	2	60
	4	3	Yes	1	4	2	60

<sup>a</sup> For the purpose of this table, a conductor that is used to carry the unbalanced current from the other conductors is not counted as a circuit conductor.

<sup>b</sup> Lengths specified are for outdoor-use cord sets only.

<sup>c</sup> The ampacity rating for over 50 ft (15.2 m).

<sup>d</sup> The maximum length of a cord set with 3 outlets in the cord connector shall be 100 ft (30.5 m).

<sup>e</sup> See the applicable Section for the specific requirements for each type of outdoor-use cord set.

### 31 Attachment Plug

31.1 The attachment plug shall be resistant to sunlight, mechanical abuse, moisture, and shall exclude moisture by adhering tightly to the jacket of the cord at the point that the jacket or the cord enters the plug (see test in 60.2).

31.2 A molded attachment plug of butyl rubber, neoprene or polyvinyl chloride is acceptable if it complies with the adhesion test in 60.2. Molded-on plugs of other materials are acceptable if determined so by the results of an appropriate investigation.

31.3 The plug for a 2-wire outdoor-use cord set shall have the 2-wire polarized configuration rated 15 A at 125 V. For other than a 2-wire outdoor-use cord set, the attachment plug shall be of the grounding type.

## 32 Cord Connector

32.1 The cord connector shall be resistant to sunlight and mechanical abuse, and shall exclude moisture by tightly adhering to the jacket of the cord at the point that the cord enters the body (see 60.2).

32.2 The cord connector may have a maximum of 3 outlets. The configuration of the contact members shall be the same for the cord connector as the attachment plug.

32.3 The outlet faces of a cord connector employed on an outdoor-use cord set shall remain in a vertical plane (the outlet faces shall not land face up or face down) when tested as described in the Random Drop Test, Section 98.

*Exception No. 1: A single-outlet cord connector having the outlet face positioned directly opposite the cord entry (in-line) is considered to comply with this requirement and need not be subjected to the Random Drop Test.*

*Exception No. 2: A 3-outlet grounding-type cord connector using the parallel-slot configuration rated 15 A, 125 V need not comply with this requirement if:*

- a) The length and width dimensions are at least three times the maximum thickness dimensions (the thickness shall not include the grounding-pin obstruction or obstructions);*
- b) There is no outlet in the surfaces formed by the length and width dimensions; and*
- c) The angle between the adjacent faces containing outlets is not less than 135 degrees. See Figure 32.1.*

32.4 A molded-on cord connector of butyl rubber, neoprene, or polyvinyl chloride shall comply with the adhesion test of 60.2. Molded-on cord connectors of other materials are acceptable if determined so by the results of an appropriate investigation.

32.5 The cord connector of a 2-wire outdoor-use cord set shall have the 2-wire, polarized, 15-A, 125-V configurations. For other than a 2-wire outdoor-use cord set, the cord connector shall be of the grounding type.

32.6 When two or more parallel-slot outlets are on the same surface of a cord connector, they shall be spaced apart so that adjacent plugs having the minimum face size shown in Figure 25.2 can be fully inserted with no exposed blades.

32.7 To prevent a 3-wire grounding-type attachment plug of a NEMA 5-15P, 6-15P, or 6-30P configuration from being inserted into a grounding cord connector in reverse or into a 2-wire nongrounding-type cord connector (thereby enabling the grounding pin not to engage a grounding contact within the cord connector), one obstruction shall be provided on a grounding-type cord connector and two obstructions shall be provided on a 2-wire cord connector. Each obstruction shall be sufficiently large and substantial to prevent deliberate displacement of the grounding pin, other attachment plug contact members, or both during, and as a result of, improper mating of the attachment plug with the cord connector. An obstruction shall not contain any holes, grooves, thin or flexible areas, or other means that make it possible to defeat the intent of this requirement. The shape of an obstruction is not specified but shall meet the minimum requirements for the cord connectors as shown in Figure 32.2.

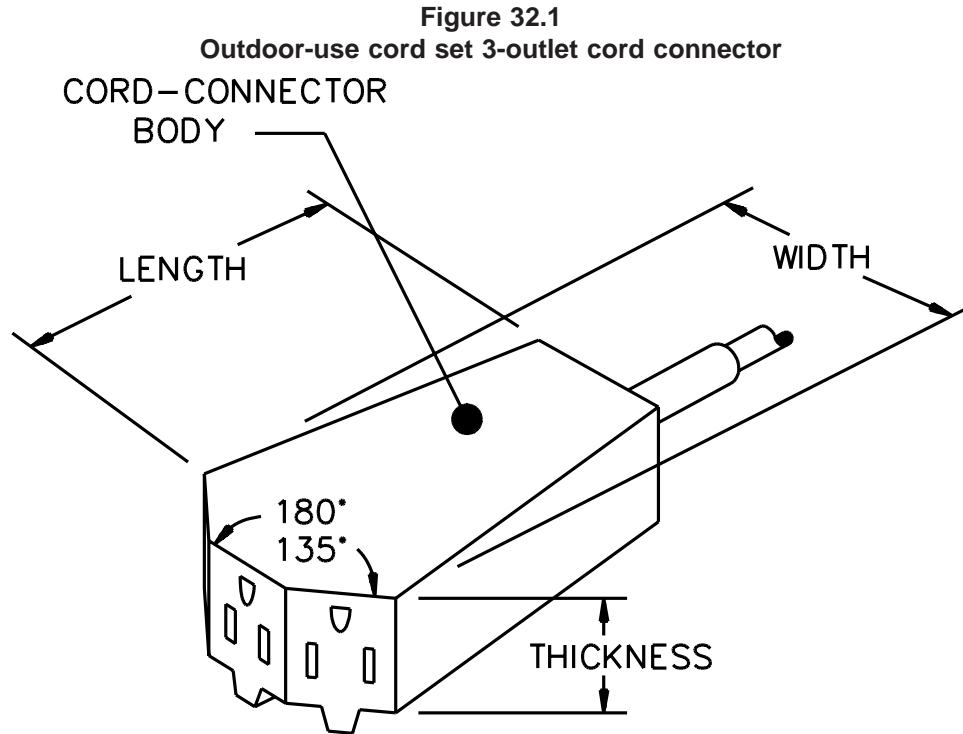

SB0902

32.8 Each outlet of a cord connector of an outdoor-use cord set employing one of the 2-pole, 2- or 3-wire, 15 or 20-A, 125-V configurations shown in Figures C1.1, C1.5, or C1.6, shall be tested as described in Low-Temperature Insertion Test, Section 97, to determine that the connector(s) are capable of low-temperature connection.

32.8 revised March 16, 2001

### 33 Switches

33.1 A switch provided on an outdoor-use cord set shall comply with the requirements for switches provided on general-use cord sets, 18.1 – 18.4.

33.2 Each switch provided on an outdoor-use cord set shall have an enclosure to reduce the likelihood of persons unintentionally contacting uninsulated live parts of the switch.

33.3 The enclosure of a switch provided on an outdoor-use cord set shall be comprised of material that meets the requirements of the Standard for Polymeric Materials – Use in Electrical Equipment Evaluations, UL 746C, and shall have a minimum flammability rating of HB.

33.4 A switch enclosure shall be of a material having moisture absorptive properties in accordance with the Standard for Polymeric Materials – Short Term Property Evaluations, UL 746A. Molded phenolic and similar thermosetting polymeric materials are considered to have moisture-absorptive properties acceptable for use as a switch enclosure.

*Exception: Fiber and similar absorptive materials are not considered to have moisture-absorptive properties acceptable for use as the enclosure of a switch.*

**Figure 32.2**  
**Faces of parallel-slot and tandem-slot cord connectors showing the smallest acceptable obstruction for the grounding pin on mating or similar attachment plugs**

All dimensions are in inches

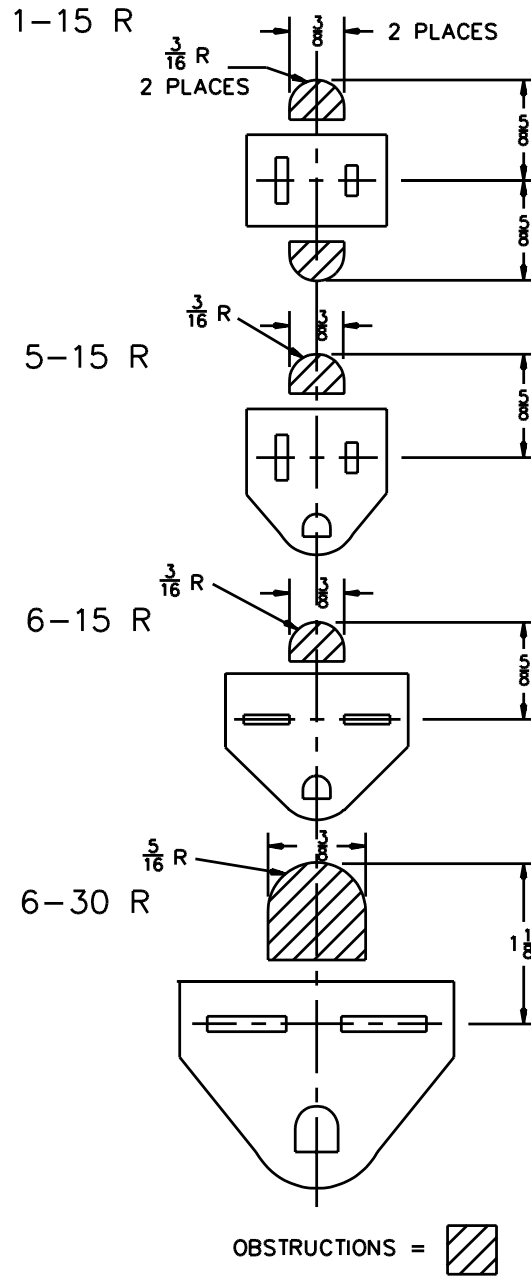

SC0557

Inch	3/16	5/16	3/8	5/8	1-1/8
mm	4.8	7.9	9.5	15.9	28.6

33.5 The enclosure of a switch intended for use on an outdoor-use cord set shall not permit water to enter that portion of an attachment plug or current tap which serves as the enclosure of the switch so as to contact live parts as determined using the test described in 101.6.1 – 101.6.4.

### 34 Rating

34.1 An outdoor-use cord set shall be rated in maximum volts, maximum amperes, and maximum watts.

34.2 Tables 115.1– 115.5 show the ratings and applicable line and load fittings for the cord sets in which the attachment plug and cord connector are of the same contact configuration.

34.3 The ampacity for each cord set in Tables 115.1 – 115.5 is the maximum current rating in amperes of either the flexible cord [derated two AWG sizes for cord sets longer than 50 ft (15.2 m)] or the fittings used, whichever is lower.

34.4 Because all of the fittings shown have voltage ratings lower than the ratings of the flexible cords specified (Types SOW, SOOW, STW, STOW, STOOW, SEW, and SEOW, and SEOOW are rated 600 V, and Types SJOW, SJOOW, SJTW, SJTOW, SJTOOW, SJEW, SJEOW, and SJEOW are rated 300 V), each cord set maximum voltage rating in Tables 115.1 – 115.5 is the voltage rating of the fittings used. When determining the maximum wattage rating of an outdoor-use cord set the following items shall be considered:

- a) Each cord-set wattage rating in Tables 115.1 – 115.5 is the result of multiplying the voltage rating of the line fitting by the ampacity of the flexible cord or ampere rating of the load fitting, whichever is lower.
- b) When 3-phase fittings are used, the wattage rating of the cord set is 1.732 times higher than the rating determined in (a).
- c) When fittings with a dual rating of 125/250 V are used in a 3-wire circuit, the maximum wattage rating of the cord set shown in Table 115.4 is the result of multiplying the maximum voltage rating of the fittings, 250 V, by the ampacity of the flexible cord or the fitting, whichever is lower.

34.4 revised March 16, 2001



## 35 Marking

35.1 Each outdoor-use cord set shall be legibly marked with all of the following:

- a) The type letter designation of the cord shall appear on the cord jacket. See 30.1.
- b) The word "outdoor" may also appear on the jacket. See 30.3.
- c) The electrical ratings (see Rating, Section 34).
- d) The wording "Suitable for use with outdoor appliances – store indoors while not in use" (see 35.2).

35.1 revised March 16, 2001

35.2 The markings specified in 35.1(d) are to be made by one of the means described in 23.6. The first part ("Suitable for use with outdoor appliances") of the marking specified in item d of 35.1 is to be marked on the manufacturer's portion of the combination label. The second part ("store indoors while not in use") is to be the same type and size as the first if marked on the manufacturer's portion of the combination label. If the second part is marked elsewhere, the cord set is to be in its own package or wrapper that is marked with both parts, the second part immediately following the first, and both parts in the same type and size letters [letters with a height of 1/8 inch (3.2 mm) are the smallest ones acceptable].

35.3 Each 2-wire outdoor-use cord set intended for use with outdoor appliances shall be permanently marked "CAUTION – To reduce the risk of electric shock, do not use with any appliance or tool with a 3-wire grounding-type plug," or the equivalent. The marking specified shall be on a tear-resistant tag permanently affixed to the cord set within 12 inches (305 mm) of the load fitting.

35.4 The wrapper or equivalent packaging of a 2-wire cord set intended for use with outdoor appliances shall be marked "CAUTION – This cord set is specifically designed for 2-wire appliances. To minimize the risk of electric shock, do not use with any appliance or tool with a 3-wire grounding-type plug," or the equivalent.

35.5 Outdoor-use cord sets having 2-pole, 2-wire, 15-A, 125-V fittings shall be marked as described in 23.12 and 23.13 (instructions for use of polarized cord sets).

35.6 The line and load fittings of an outdoor-use cord set may be marked with a current rating only if they meet the requirements in 23.7 and 23.8, respectively.

35.7 An outdoor-use cord set that employs fittings of the C1.1, C1.5, C1.6, C2.1, or C2.3, C2.4, C2.6 or C2.7 configuration as specified in the Standard for Wiring Device Configurations, UL 1681, shall comply with the marking tag requirements in 23.14 – 23.16.

Revised 35.7 effective March 16, 2003

## ADAPTER CORD SETS

### 36 General

36.1 In addition to the requirements under this heading, an adapter cord set shall comply with the requirements in Sections 28 – 35.

36.2 An adapter cord set is intended for use at locations such as construction sites and is designed:

- a) To provide power from one plug configuration to a single-outlet configuration. See Figure 36.1 and Table 36.1.
- b) To provide 2 or 3 outlets on one connector body of the same configuration as the plug or convert to another configuration. See Figure 36.2 and Table 36.1.
- c) To convert from one plug to 2 or 3 single-outlets of the same configuration as the plug or convert to another configuration. See Figure 36.3 for typical constructions and Table 36.1.
- d) To provide power to, based on the wire gauge and length specified in Table 36.2, a maximum of either 3 or 6 in-line outlets. See Figure 36.4 and Table 36.2.

36.2 revised June 24, 2003

**Table 36.1**  
**Adapter cord set fittings and cord length**

Table 36.1 added June 24, 2003

Attachment plug rating	Cord connector rating	Max. cord length, ft (m)	Minimum gauge, AWG
15 A	15 A	50 (15.2)	14
15 A	15 A	100 (30.5)	12
15 A	20 A	2 (0.6)	14
20 A	15 A	50 (15.2)	14
20 A	15 A	100 (30.5)	12
20 A	20 A	50 (15.2)	12
20 A	20 A	100 (30.5)	10

Notes:

- 1 – It is permitted to have 2 or 3 lengths of cord exiting the joint.
- 2 – Other NEMA configurations rated 30, 50, and 60 A employing No. 10, 6, and 4 AWG cord respectively are also permitted.
- 3 – Adapter cord sets utilizing 15 or 20 A attachment plugs are permitted to employ the same or different configurations of line and load fittings.

**Table 36.2**  
**Fittings and cord length for adapter cord sets employing in-line outlets**

Table 36.2 added June 24, 2003

Attachment plug rating	Cord connector rating	Max. cord length, ft (m)	Minimum gauge, AWG	Max. no. of outlets
15 A	15 A	50 (15.2)	14	3
15 A	15 A	100 (30.5)	12	3
20 A	15 A	50 (15.2)	12	6
20 A	15 A	100 (30.5)	10	6

36.3 An adapter cord set is an assembly consisting of an attachment plug, a length of extra-hard-usage flexible cord, and one or more load fittings providing a total of not more than 6 outlets.

36.3 revised June 24, 2003

**Figure 36.1**  
**Single to single configuration**

Figure 36.1 added June 24, 2003

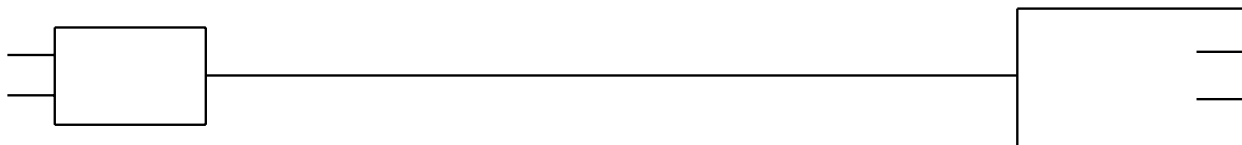

S4405

**Figure 36.2**  
**Multiple outlets with no joints**

Figure 36.2 added June 24, 2003



S4406

**Figure 36.3**  
**Multiple single outlets with joints**

Figure 36.3 added June 24, 2003

Two outlets

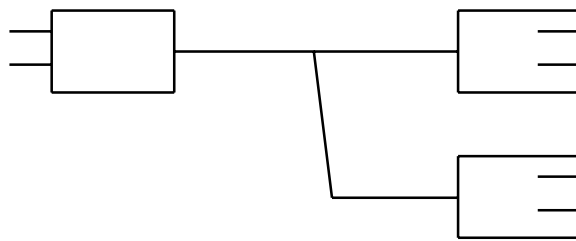
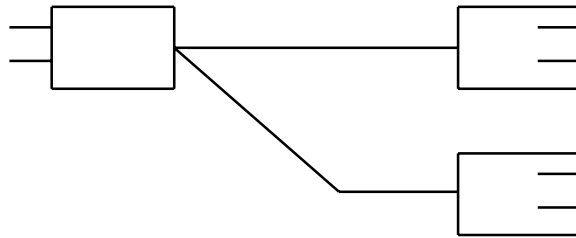

Three outlets

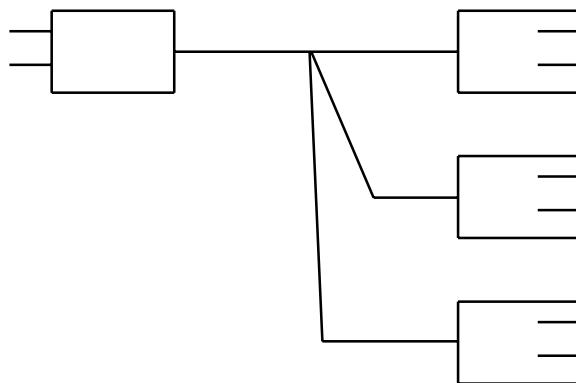
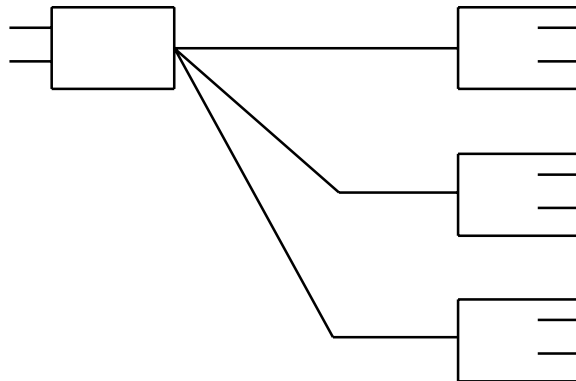

**Figure 36.4**  
**Adapter cord sets employing in-line outlets**

Figure 36.4 added June 24, 2003

Maximum six outlets

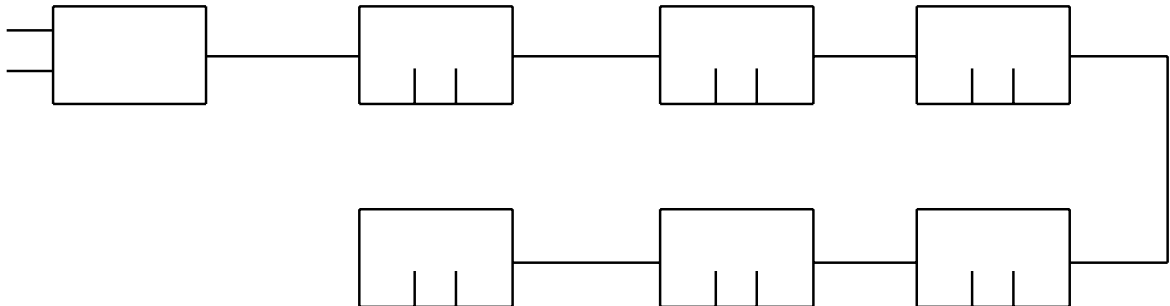

Maximum three outlets

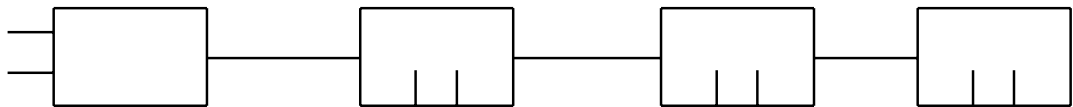

S4408

### 37 Fittings

37.1 An adapter cord set may employ the same or different configurations of line and load fittings and may include more than one configuration of load fittings. An adapter cord set with a multiple-outlet load fitting that incorporates both straight-blade and locking configurations on the same multiple-outlet fitting meets the intent of this requirement.

37.1 revised June 24, 2003

37.2 The line and load fittings shall be of the grounding type and their voltage and current ratings shall be the same except that an attachment plug rated 20 A used in combination with an outlet or outlets rated 15 A and an attachment plug rated 15 A used in combination with a single outlet rated 20 A meet the intent of the requirement.

37.2 revised June 24, 2003

### 38 Flexible Cord

38.1 The interconnecting flexible cord shall be Type SOW, SOOW, STW, STOW, STOOW, SEW, SEOW, or SEOOW with a grounding conductor. The conductors shall not be smaller than 14, 12, 10, 6, and 4 AWG when end fittings rated 15, 20, 30, 50, and 60 A, respectively, are employed.

38.1 revised June 24, 2003

38.2 With the exception of 38.3, the length of an adapter cord set is to be measured from the face of the line fitting to the face of any load fitting and shall not exceed 100 ft (30.5 m).

38.2 revised June 24, 2003

38.3 The length of an adapter cord set employing a 15-A plug and 20-A outlet shall not be greater than 2 ft. (0.6 m).

38.3 added June 24, 2003

### 39 Joints

39.1 An adapter cord set with more than one single-outlet load fitting may have a joint in the flexible cord with the cord branching to two or three cords, each terminating in a single-outlet load fitting.

39.2 The resistance of the joint insulation to sunlight and mechanical abuse shall be at least equal to that of the interconnecting flexible cord. Molded-on joint insulation shall be compatible with the material used in the jacket of the flexible cord and shall adhere tightly to the jacket so as to exclude moisture.

39.3 A joint between two or more flexible cords in an adapter cord set shall have a minimum insulating-body thickness of 3/32 inch (2.4 mm) covering all live parts.

39.4 The thickness mentioned in 39.3 is to be measured from any part of the live contacts and uninsulated flexible-cord conductors (conductors from which the flexible-cord insulation has been removed) to the nearest point on the outer surface of the insulating body.

39.5 Insulation of neoprene, polyvinyl chloride, or butyl rubber is acceptable provided its adhesion to the cord jacket complies with 60.2. Joint insulation of other material may be investigated to determine its acceptability.

## 40 Rating

40.1 Tables 115.1 – 115.5 shall be applied to an adapter cord set. The values for cord-set lengths of 6 – 50 ft (1.8 – 15.2 m) shall be used for adapter cord sets less than 50 ft (15.2 m) long.

40.1 revised June 24, 2003

40.2 The electrical ratings of the adapter cord set shall be based on the ampere rating of the lowest rated fitting used.

40.3 An adapter cord set shall be rated in maximum volts, maximum amperes, and maximum watts.

## 41 Marking

41.1 Each adapter cord set shall be legibly marked with all of the following:

- a) The type letter designation for the cord shall appear on the cord jacket. See 30.1.
- b) The word “outdoor” may also appear on the jacket. See 30.3.
- c) The electrical ratings (see Ratings, Section 40).
- d) The wording “Suitable for use with outdoor appliances – store indoors while not in use” (see 35.1(d) and 35.2).
- e) The wording “Intended for use on construction sites or similar locations”

Revised 41.1 effective June 24, 2006

41.2 An adapter cord set having the line fitting rated less than the load fitting shall be additionally marked by one of the means described in 23.6 to caution the user not to overload the branch circuit and the adapter cord set. The cautionary marking shall also include the rating of the adapter cord set in accordance with Rating, Section 40.

## RECREATIONAL-VEHICLE CORD SETS

### 42 General

42.1 Each recreational-vehicle cord set shall consist of an attachment plug and a length of flexible cord connected to a single-outlet cord connector that complies with 42.2 and 43.1. The attachment plug and flexible cord employed shall comply with the requirements in 56.1, 56.2, and 57.1 – 57.3 (in the recreational-vehicle power-supply cord requirements). A recreational-vehicle cord set may not employ a through-cord switch.

42.2 The length of the finished assembly shall not be less than 30 ft (9.1 m) when measured according to 6.4.

*Exception: The minimum length for cord sets intended for shipment to an OEM is 23 ft (7.01 m).*



**43 Fittings**

43.1 The cord connector shall be of a 2-pole, 3-wire or 3-pole, 4-wire grounding configuration identical in ratings and configuration to the attachment plug attached to the supply end of the cord. The cord connector shall be molded butyl rubber, neoprene, or polyvinyl chloride (or other equivalent materials) and shall be so molded to the flexible cord that it adheres tightly to the jacket of the cord at the point at which the cord enters the connector body (see 60.2). If a right-angle body is used, the configuration shall be so oriented that the grounding member is the member farthest from the point of cord entry.

**POWER-SUPPLY CORDS**

**44 General**

44.1 Power-supply cords shall comply with the general requirements in Sections 6 – 15.

44.2 A power-supply cord may be either of the detachable or nondetachable type. See 2.9, 2.12 and 64.1.

44.3 In a power-supply cord there shall be a conductor attached to each blade or pin in the line fitting and there shall be a blade or pin provided in the line fitting for each conductor in the cord.

*Exception: An antenna power-supply cord shall have the antenna conductor unterminated at the line fitting.*

44.4 An individually packaged power-supply cord intended for replacement purposes shall be marked to indicate the size of each conductor, its electrical rating, and temperatures rating. The marking may be on the packaging material, on the cord, or may be in the forms described in item (b) or (c2) of 23.6.

44.5 The flexible cord of a power-supply cord shall be one of the cords in Table 44.1. The maximum circuit-conductor ampacity of cords used in power-supply cords shown in Tables 114.1 – 114.3.

**Table 44.1**  
**Types of flexible cord, cable, and wire for power-supply cords**

Table 44.1 revised March 16, 2001

Tinsel cords	Heater cords	General-use cords				Specific-purpose cords, cables, and wires
		C	SP-1	SV	SJ	
TPT		PD	SPT-1	SVO	SJO	
TS		S	SPE-1	SVOO	SJOO	
TST	HPD	SO	SP-2	SVT	SJT	XTW
	HPN	SOO	SPT-2	SVTO	SJTO	CXTW
	HS	ST	SPE-2	SVTOO	SJTOO	Clock
	HSO	STO	SP-3	SVE	SJE	SRD
	HSOO	STOO	SPT-3	SVEO	SJEO	SRDT
	HSJ	SE	SPE-3	SVEOO	SJEOO	SRDE
	HSJO	SEO	NISP-1	NISPE-1	NISPT-2	Shaver
	HSJOO	SEOO	NISPT-1	NISP-2	NISPE-2	
NOTES TO TABLE 44.1						
<sup>a</sup> Tinsel cords are limited to use in power-supply cords not larger than 8 ft. (2.4 m) overall, including the line fitting and load fitting (when provided) but excluding the blades of an attachment plug.						

Table 44.1 Continued

Tinsel cords	Heater cords	General-use cords	Specific-purpose cords, cables, and wires
<p><sup>b</sup> A Type SOW, SOOW, STW, STOW, STOOW, SEW, SEOW, SEOOW, SJOW, SJOOW, SJTW, SJTOW, SJTOOW, SJEW, SJEOW or SJOOW cord is not acceptable for use in power-supply cords.</p> <p><sup>c</sup> Type SOW, SOOW, STW, STOW, STOOW, SEW, SEOW and SEOOW cord that is marked "For mobile-home use: ___amperes" is limited to use in power-supply cords for mobile homes. A Type SOW, SOOW, STW, STOW, STOOW, SEW, SEOW, or SEOOW cord marked "For recreational vehicle use: ___amperes" is limited to use in power-supply cords for recreational vehicles.</p> <p><sup>d</sup> Types SP-3, SPT-3, and SPE-3 cords are acceptable for use in power-supply cords for certain appliances that are not frequently moved.</p> <p><sup>e</sup> In SP-1, NISP-1, SP-2, NISP-2, SP-3, SPT-1, NISPT-1, SPT-2, NISPT-2, SPT-3, SPE-1, NISPE-1, SPE-2, NISPE-2, SPE-3, SV, SVO, SVOO, SVT, SVTO, SVTOO, SVE, SVEO, SVEOO and HPN type cords the third conductor is for grounding purposes only.</p> <p><sup>f</sup> Types SP-2, SPT-2, and SPE-2 cords employing No. 30 AWG stranding are limited to use in general-use cord sets that are not likely to be subjected to frequent flexing.</p> <p><sup>g</sup> Types XTW, CXTW, clock cords, and shaver cords, are limited to use in power-supply cords marked as required in 63.2.</p> <p><sup>h</sup> Types SRD, SRDT, and SRDE cables are limited to use where they are not subject to frequent flexing such as with electric ranges and clothes dryers and other appliances rated 30 A or greater that are not frequently moved.</p> <p><sup>i</sup> Cord constructions that can be demonstrated to be equivalent to integral Type SPT-2 flexible cord may be used in power-supply cords having a retractile (coiled) cord construction.</p> <p><sup>j</sup> Cord types that employ a shield or a shield and drain wire (see Use of Shielded Cord, Section 46) are identified by the word "shielded" marked on the outer surface of the cord.</p> <p><sup>k</sup> The use of shaver cord is limited to factory-assembled power-supply cords intended for hand-held hair clippers and shaving appliances rated 50 W or less.</p> <p><sup>l</sup> Appliance Wiring Material constructed similarly to Type SPT-1 flexible cord except that the extruded PVC insulation thicknesses are: 40 mils average minimum, 35 mils minimum at any point before separation, 19 mils minimum at any point after separation, and 60 mils minimum between conductors is acceptable for use with chain-suspended portable lamps.</p> <p><sup>m</sup> A No. 20 AWG (0.52 mm<sup>2</sup>) power-supply cord constructed of Appliance Wiring Material having No. 36 – 34 AWG (0.013 – 0.020 mm<sup>2</sup>) stranding and insulation (and jacket, if appropriate) having a thickness equal to the insulation thickness of the flexible cord type it is intended to replace, if acceptable for use as described in 49.2 and 65.8.</p>			

#### 44.6 Two-wire power-supply cords with polarized or unpolarized parallel-blade attachment plugs or current taps rated 15 A, 125 V and employing 2-conductor

No. 27 AWG, Types TPT, TS, TST, and shaver cord,

No. 20 AWG, Types SP-1, NISP-1, SPE-1, NISPE-1, SPT-1, NISPT-1,

No. 20 AWG, Appliance Wiring Material constructed in accordance with note m of Table 44.1,

No. 20 AWG, clock cord,

No. 18, 20, 22, 24 AWG, Type XTW, CXTW,

No. 18 AWG, Types HPN, SP-1, NISP-1, SP-2, NISP-2, SPT-1, NISPT-1, SPT-2, NISPT-2, SPE-1, NISPE-1, SPE-2, NISPE-2, HPD, SV, SVO, SVOO, SVT, SVTO, SVTOO, SVE, SVEO, SVEOO,

No. 17 AWG, Types HPN, HPD, SV, SVO, SVOO, SVT, SVTO, SVTOO, SVE, SVEO, SVEOO,

No. 16 AWG, Types HPN, SP-2, NISP-2, SPT-2, NISPT-2, SPE-2, NISPE-2, HPD

flexible cord shall employ attachment plugs or current taps that comply with 25.1.1 – 25.3.1.

*Exception No. 1: Television-receiver power-supply cords describe in 62.2 and 75.1 need not comply with this requirement.*

*Exception No. 2: A power-supply cord of a toy transformer or electric toy need not comply with this requirement. See 62.3.*

*Exception No. 3: A power-supply cord intended for use with a vacuum cleaner or floor finishing machine as described in 62.4 and 77.1 need not comply with this requirement.*

44.6 revised June 24, 2003

## 45 Switches

45.1 A through-cord switch may be employed on a power-supply cord except for:

- a) Those types covered in Sections 52 – 61,
- b) Those intended for replacement use, and
- c) Antenna power-supply cords.

*Exception: A replacement use power-supply cord for use with a television receiver may employ a through-cord switch. See 45.5(a).*

45.2 A through-cord switch employed on a power-supply cord shall be

- a) Rated not less than “6A, 125 V – 3A, 250 V” or “10 A, 120 V AC”, and
- b) Acceptable for the appliance load it is intended to control.

45.3 A switch on a polarized power-supply cord shall either simultaneously open all of the supply conductors or shall open only the unidentified conductor.

45.4 A switch shall not open a grounding conductor of a power-supply cord.

45.5 A through-cord switch on a power-supply cord for use with a television receiver shall:

- a) Have a minimum rating of TV-5, when the power-supply cord is detachable or intended for replacement use, and
- b) Have a TV-rating that is appropriate for the intended appliance, when the power-supply cord is intended for shipment to original equipment manufacturers.

## 46 Use of Shielded Cord

46.1 A power-supply cord may employ shielded cord provided the shield or drain wire is terminated, along with the grounding conductor, to both the grounding terminal of the attachment plug and, in the case of a detachable power-supply cord, to the grounding terminal of the appliance coupler.

*Exception: If marked as described in 46.2, the shield and drain wire need not be terminated, along with the grounding conductor, to the grounding terminal of either fitting. See 16.7.*

46.2 A power-supply cord employing shielded cord that does not have the shield or drain wire terminated, along with the grounding connector, to the grounding terminal of the attachment plug, load fitting, or both, shall be indelibly marked with the following or the equivalent: "CAUTION: The shield in this cord is not terminated to any of the terminals in the \_\_\_\_." The blank is to be filled-in with one of the following: "attachment plug", "appliance coupler", or "attachment plug or appliance coupler", as appropriate.

46.3 The marking described in 46.2 shall be provided on a permanent tag attached to flexible cord within 6 inches (152 mm) of the line fitting.

## 47 Overcurrent Protection

47.1 A 2-wire power-supply cord having No. 20 AWG (0.52 mm<sup>2</sup> conductors, employing either appliance wiring material constructed in accordance with note m to Table 44.1, or Type SP-1, NISP-1, SPE-1, NISPE-1, SPT-1, or NISPT-1 flexible cord shall be provided with overcurrent protection (short circuit and overload protection) rated less than or equal to 2 A.

47.1 revised March 16, 2001

47.2 The overcurrent protective device shall have a minimum short circuit rating of 1000 A and may be of the replaceable or manually resettable type. A replaceable fuse shall be of a readily available type to reduce the likelihood of the plug being replaced with one that is unfused. The overcurrent protective device shall not be of the automatic resetting type.

47.3 The overcurrent protective device shall be located in the attachment plug. See also Fittings Intended to Accommodate Fuses or Other Overcurrent Protective Devices, Section 14.

47.4 Thermal cutouts, thermal relays, or other devices not intended to open short circuits shall not be used to provide the protection required in 47.1.

47.5 The overcurrent protective device of a polarized attachment plug shall provide protection for the ungrounded circuit conductor only.

*Exception: A multi-pole overcurrent protective device may be used if it opens both the ungrounded and grounded circuit conductors and cannot open the grounded circuit conductor without opening the ungrounded circuit conductor.*

47.6 The overcurrent protective device of a non-polarized attachment plug shall open both the grounded and ungrounded circuit conductors.

## NONDETACHABLE POWER-SUPPLY CORDS

### 48 General

48.1 The third conductor of an antenna power-supply cord is to be clearly severed and secured within the body so that flexing of the cord will not expose the third conductor.

48.2 An antenna power-supply cord is to be marked in accordance with 51.4.

### 49 Fittings

49.1 The fitting for line connection shall be an attachment plug, except that a multiple-connected current tap may be used for the line fitting on power-supply cords not intended for outdoor use.

49.2 A non-detachable power-supply cord having No. 20 AWG (0.52 mm<sup>2</sup>) conductors, and employing either appliance wiring material constructed in accordance with note m to Table 44.1, or Type SP-1, NISP-1, SPE-1, NISPE-1, SPT-1 or NISPT-1 flexible cord shall:

- a) Have a 2-pole, 2-wire line fitting of the 15 A, 125 V type that complies with 25.1.1– 25.3.1; and
- b) Be provided with overcurrent protection in accordance with Overcurrent Protection, Section 47.

49.2 revised March 16, 2001

### 50 Flexible Cord

50.1 The flexible cord of a nondetachable power-supply cord shall be one of the cords in Table 44.1.

### 51 Marking

51.1 An individually packaged nondetachable power-supply cord intended for replacement use shall be marked to indicate its cord type, cord length, conductor size, number of conductors, electrical rating, and temperature rating if other than the lowest temperature rating permissible for the particular cord type used. The marking shall be provided on the packaging material.

*Exception: Any marking provided on the cord is not required to be repeated on the packaging when the markings are visible through the packaging.*

51.1 revised June 24, 2003

51.2 A nondetachable power-supply cord rated 50 W or less shall also be marked "For use with hand-held appliances rated 50 watts or less, 125 volts" (or 250 V, depending on the rating of the attachment plug).

51.3 Nondetachable power-supply cords intended for shipment to original equipment manufacturers shall have any applicable markings (see General, Section 15; Markings, Section 51; and Marking, Section 63) provided on the outer surface of the shipping carton, or on a tag or the equivalent inside the carton. The electrical rating need not be marked.

51.4 The shipping container of an antenna power-supply cord shall be marked with the following or equivalent: "For use with radio receivers only."

51.5 Individually packaged power-supply cords intended for replacement use having polarized 2-pole, 2-wire attachment plugs or current taps of the 15-A, 125-V configuration, shall be marked with the following information:

This is a POLARIZED power-supply cord.

It has a polarized plug (one blade is wider than the other).

This plug is not intended to be mated with a nonpolarized outlet (having both slots the same size).

Install so that original polarity is maintained.

51.6 The markings required by 51.5 are to be legible, distinct, and prominently displayed on the outer surface of the smallest unit package and shall comply with the following:

- a) The word "POLARIZED" in the first element of the marking is to be of boldface capital letters a minimum of 9/64 inch (3.6 mm) high and the remaining words are to be a minimum of 1/16 inch (1.6 mm) high.
- b) The color of the letters shall contrast with a solid color background.

51.7 The marking of a replacement-use nondetachable power-supply cord shall include installation instructions which address each of the following items:

- a) Whether the power-supply cord is of the grounding or nongrounding type,
- b) If nongrounding, whether the power-supply cord is polarized or nonpolarized (for example, by a pictorial representation depicting the difference in blade widths),
- c) If polarized, how to identify the ungrounded (neutral) conductor (for example, using a pictorial representation or through precise instructions),
- d) Instructions for the user to disconnect the appliance at the plug before attempting to remove the old power-supply cord from terminals on the appliance, and
- e) Instructions for the user not to plug in the replacement power-supply cord until all necessary terminals on the appliance have been completed and the product is completely reassembled.

51.8 Bulk-packaged nondetachable power-supply cords intended for replacement use shall be provided with installation instructions as described in 51.7, attached to each power-supply cord in the bulk shipping carton.

51.9 The instructions described in 51.7 shall appear on the smallest unit carton, card, or blister pack, or on a stuffer sheet included inside an individual package.

## POWER-SUPPLY CORDS FOR RANGES AND DRYERS

### 52 General

52.1 Each power-supply cord for range and dryer application shall be nondetachable and employ Type SRD, SRDT, or SRDE flexible cable, and shall be rated in accordance with Table 52.1.

**Table 52.1**  
**Circuit-conductor ampacity and voltage rating for range and dryer cables (Types SRD, SRDT, and SRDE)**

Number, size and use of conductors in cable		Ampacity of circuit conductors of cable (Amperes)	Voltage rating of cable (Volts)
2 1	No. 10 AWG unidentified circuit and No. 10 AWG grounded circuit	30 <sup>a</sup>	300
2 1 1	No. 10 AWG unidentified circuit and No. 10 AWG grounded circuit and No. 10 AWG grounding	30 <sup>a</sup>	300
3 1	No. 10 AWG unidentified circuit and No. 10 AWG grounded circuit	25 <sup>a</sup>	300
2 1	No. 8 AWG unidentified circuit and No. 10 AWG grounded circuit	40 <sup>a</sup>	300
2 1 1	No. 8 AWG unidentified circuit and No. 10 AWG grounded circuit and No. 10 AWG grounding	40 <sup>a</sup>	300
3 1	No. 8 AWG unidentified circuit and No. 10 AWG grounded circuit	36 <sup>c</sup>	300
2 1	No. 8 AWG unidentified circuit and No. 8 AWG grounded circuit	40 <sup>a</sup>	300
3 1	No. 8 AWG unidentified circuit and No. 8 AWG grounded circuit	35 <sup>c</sup>	300
2 1	No. 6 AWG unidentified circuit and No. 8 AWG grounded circuit	55 <sup>b,d</sup>	300
2 1 1	No. 6 AWG unidentified circuit and No. 8 AWG grounded circuit and No. 8 AWG grounding	55 <sup>b</sup>	300
3 1	No. 6 AWG unidentified circuit and No. 8 AWG grounded circuit	45 <sup>c</sup>	300
2 1	No. 6 AWG unidentified circuit and No. 6 AWG grounded circuit	55 <sup>b,d</sup>	300
3 1	No. 6 AWG unidentified circuit and No. 6 AWG grounded circuit	45 <sup>c</sup>	300

Table 52.1 Continued on Next Page

Table 52.1 Continued

Number, size and use of conductors in cable		Ampacity of circuit conductors of cable (Amperes)	Voltage rating of cable (Volts)
2 1	No. 4 AWG unidentified circuit and No. 6 AWG grounded circuit	70 <sup>b,d</sup>	300
2 1 1	No. 4 AWG unidentified circuit and No. 6 AWG grounded circuit and No. 6 AWG grounded	70 <sup>b,e</sup>	300
3 1	No. 4 AWG unidentified circuit and No. 6 AWG grounded circuit	60 <sup>c</sup>	300
2 1	No. 4 AWG unidentified circuit and No. 4 AWG grounded circuit	70 <sup>b,d</sup>	300
3 1	No. 4 AWG unidentified circuit and No. 4 AWG grounded circuit	60 <sup>c</sup>	300
<p><sup>a</sup> The circuit-conductor ampacity is to be reduced by 5 A if grounded circuit conductor carries current other than unbalanced current.</p> <p><sup>b</sup> The circuit-conductor ampacity is to be reduced by 10 A if grounded circuit conductor carries current other than unbalanced current.</p> <p><sup>c</sup> The circuit-conductor ampacity is to be reduced to 80 percent of the value shown if the grounded circuit conductor carries other than unbalanced current.</p> <p><sup>d</sup> When assembled into power-supply cords the ampacity is to be limited to 50 A to correlate with rating of the standard 3-pole, 3-wire attachment plug configuration employed.</p> <p><sup>e</sup> When assembled into power-supply cords the ampacity is to be limited to 60 A to correlate with the rating of the standard 3-pole, 4-wire attachment plug configuration employed.</p>			

## 52A Attachment Plug

Section 52A added January 14, 2004

52A.1 A power-supply cord intended for use with a range or dryer shall be provided with a 30- or 50-A, 125/250 V attachment plug having a 10-30P, 14-30P, 10-50P, or 14-50P configuration. The attachment plug blades shall comply with the dimensional requirements specified either in Wiring Devices – Dimensional Specifications, ANSI/NEMA WD6, or in Figure 52A.1.



**Figure 52A.1**  
**Padded and folded-over blade construction for 30- and 50-A attachment plugs for use with range and dryer power-supply cords**

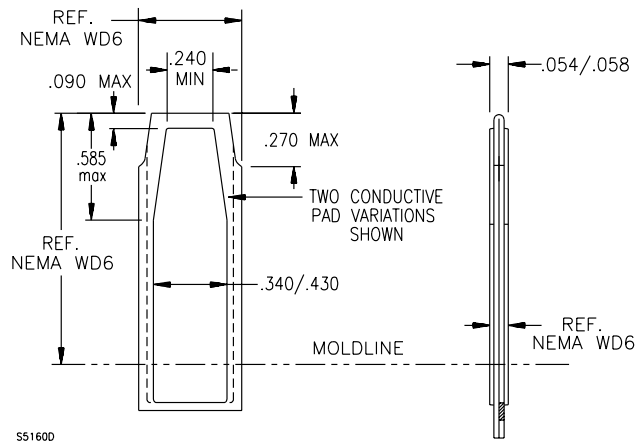

#### NOTES

- 1 Alternate blade profile for NEMA blade configurations 10-30, 10-50, 14-30, and 14-50. All location dimensions shall be as described in the applicable NEMA configurations.
- 2 The minimum material thickness for the padded and folded-over blade is 0.0270 inch.

## 53 Range and Dryer Power-Supply Cord Kits

### 53.1 General

53.1.1 A power-supply cord kit intended for use with a range or dryer shall be provided with all of the materials necessary to comply with the requirements in General, Section 52, and Attachment Plug, Section 52A. A stranded lead shall be treated so that no loose strands result – for example, by tinning of the conductor ends, or the use of crimped-on connector terminals or banding strips.

53.1.1 revised January 14, 2004

53.1.2 The length of a flexible cord and attachment plug assembly shall not be less than 4 ft (1.22 m) nor more than 6 ft (1.83 m) when measured in accordance with 6.4 and 6.5.

No Text on This Page

## 53.2 Strain relief

53.2.1 Strain relief means shall be provided so that a mechanical stress applied to the flexible cord is not transmitted to terminals, splices, or internal wiring when tested in accordance with Strain Relief Tests – Range and Dryer Power-Supply Cord Kits, Section 85.

53.2.2 The strain relief shall be constructed so as to prevent the power-supply cord from contacting the edges of the opening in the sheet metal pate when tested as described in Strain Relief Tests – Range and Dryer Power-Supply Cord Kits, Section 85, with the cord installed in the most adverse position.

53.2.3 For strain relief consisting of a threaded bushing secured by a threaded locknut, the locknut shall

- a) Be provided with notches or the equivalent for easy tightening and
- b) Have a maximum outside diameter as specified in Table 53.1.

**Table 53.1**  
**Diameter of locknut**

Maximum diameter of connection opening		Maximum outside diameter of locknut	
Inches	(mm) <sup>a</sup>	Inches	(mm)
1.140	(28.96)	1.420	(36.07)
1.406	(35.71)	1.770	(44.96)
1.765	(44.83)	2.281	(57.94)

<sup>a</sup> The applicable maximum diameter of connection opening is determined in accordance with Table 85.1.

## 53.3 Cord push-back relief

53.3.1 Means shall be provided to prevent the flexible cord from being pushed into the appliance through the strain relief mounting opening after installation. Compliance shall be determined in accordance with the test in Push-Back Test for Range and Dryer Power-Supply Cord Kits, Section 86.

## 53.4 Terminals

53.4.1 Closed loop, copper alloy terminals – or an equivalent type such as spade- or hook-type connector with upturned ears – may be provided on the conductors at the free end of the cord if the conductor terminal assembly has an ampacity equivalent to that of the flexible cord to which it is assembled. The acceptability of the assembly is to be demonstrated by compliance with the applicable test requirements in Temperature Test, Section 87.

53.4.2 The terminal shall be sized to accommodate a No. 10 or larger wire-binding screw or stud.

### 53.5 User instructions

53.5.1 Complete installation instructions shall be provided with a power-supply cord kit that is intended for use with a range or dryer. The instructions shall:

- a) Describe the method of assembly and installation, including the appropriate connection opening diameter specified in Table 85.1 and
- b) Advise the installer that after the power-supply cord has been installed, the installer is to check the continuity of the grounding conductor with an acceptable indicating device.

The instructions shall not specify:

- c) The cutting or splicing of connections or
- d) The soldering of connections.

### 53.6 Markings

53.6.1 The markings described in 53.6.2 – 53.6.5 shall be visible from the outside of the smallest shipping container or packaging.

53.6.2 In addition to the other markings required for replacement-use nondetachable power-supply cords, the shipping container of a power-supply cord kit intended for use with a range or dryer shall be legibly and permanently marked with:

- a) The manufacturer's name, trade name, or trademark,
- b) A distinctive catalog number or the equivalent,
- c) The electrical rating in volts and amperes as specified in 53.7.1 and Table 85.1, and
- d) A statement indicating acceptability for use with household electric ranges or household electric clothes dryers, or both, as applicable.

53.6.3 A power-supply cord kit that is rated 50 amperes and intended for use only in a nominal 1-3/4 inch diameter connection opening shall be marked with the following or equivalent: "For use with nominal 1-3/4 inch diameter connection opening."

53.6.4 A power-supply cord kit rated 50 amperes and intended for use only with a nominal 1-3/8 inch diameter connection opening shall be marked with the following or equivalent: "For use only with nominal 1-3/8 inch diameter connection opening."

53.6.5 A power-supply cord kit that is rated 50 amperes and intended for use with both nominal 1-3/8 and 1-3/4 inch diameter connection openings shall be marked with the following or equivalent: "Suitable for use with nominal 1-3/8 and 1-3/4 inch diameter connection opening."

## 53.7 Rating

53.7.1 The maximum current (ampere) rating of a power-supply cord kit shall be the applicable value specified in Table 85.1.

## OUTDOOR-USE POWER-SUPPLY CORDS

### 54 General

54.1 An outdoor-use power-supply cord is intended for use on outdoor appliances that are to be stored indoors while not in use. It is also acceptable for indoor use.

54.2 Each outdoor-use power-supply cord shall be either the nongrounding type containing 2 circuit conductors or the grounding type containing 2 or 3 circuit conductors and a grounding conductor.

54.3 Each outdoor-use power-supply cord shall consist of a length of flexible cord that complies with Flexible Cord, Section 30, attached to an attachment plug that complies with Attachment Plug, Section 31.

*Exception: The attachment plug of an outdoor-use power-supply cord need not be polarized.*

## POWER-SUPPLY CORDS FOR RECREATIONAL VEHICLES

### 55 General

55.1 The length of each power-supply cord for recreational vehicles shall not be less than 30 ft (9.1 m) when measured from the end of the line fitting to the cut end of the bared leads. See 6.5 and Figure 6.1.

*Exception: The minimum length for power-supply cords intended for shipment to an OEM is 23.5 ft (7.16 m).*

### 56 Flexible Cord

56.1 The flexible cord used in power-supply cords for recreational vehicles shall be Type SOW, SOOW, STW, STOW, STOOW, SEW, SEOW, or SEOOW for recreational-vehicle use. The size and number of conductors shall be in accordance with Table 56.1.

56.1 revised June 24, 2003

**Table 56.1**  
**Sizes and number of conductors in recreational-vehicle power-supply cords**

Power-supply cord rating	Total number of conductors	Number of circuit conductors	Size of circuit conductors	Size of grounding conductor
15 A	3	2	14 AWG	14 AWG
20 A	3	2	12 AWG	12 AWG
30 A	3	2	10 AWG	10 AWG
40 A	4	3	8 AWG	8 AWG
50 A	4	3	6 AWG	8 AWG
50 A	4	3	6 AWG	6 AWG

56.2 The insulation on the grounding conductor in the cord mentioned in 56.1 shall be green, or green with one or more yellow stripes. The outer surface of a cord having No. 14, 12, or 10 AWG conductors shall be marked at intervals not longer than 24 inches (610 mm) with the statement "For recreational-vehicle use: \_\_\_ amperes." The outer surface of a cord having No. 8 or 6 AWG conductors shall be similarly marked with "For mobile-home or recreational-vehicle use: \_\_\_ amperes or "For recreational-vehicle use: \_\_\_ amperes." The blank space shall be filled in with the appropriate current rating.

## 57 Fittings

57.1 The attachment plug shall be in accordance with 57.2 and 57.3. The attachment plug shall be molded of butyl rubber, neoprene, or polyvinyl chloride (or other equivalent materials), and shall be so molded to the flexible cord that it adheres tightly to the jacket of the cord at the point where the cord enters the attachment plug (see 60.2). If a right-angle attachment plug is used, the configuration shall be so oriented that the grounding member is the member farthest from the point of cord entry.

57.2 The attachment plug used with Nos. 14, 12, or 10 AWG conductors shall be a 2-pole, 3-wire grounding type having one of the configurations illustrated in Figures C1.5, C1.6, or C3.1, respectively.

57.3 The attachment plug used with Nos. 8 or 6 AWG conductors shall be the 3-pole, 4-wire grounding type illustrated in Figure C1.27.

57.4 A power-supply cord for recreational-vehicle use having No. 6 AWG circuit conductors may have the attachment plug marked 50 A. The attachment plug of a power-supply cord having No. 8 AWG circuit conductors shall not be marked with a current rating.

## POWER-SUPPLY CORDS FOR MOBILE HOMES

### 58 General

58.1 The overall length of each power-supply cord for mobile homes, measured from the end of the cord (including bared leads) to the end of the line fitting shall not be less than 21 ft (6.4 m) nor more than 36.5 ft (11.1 m). The length of the cord from the end of the line fitting to the point at which the outer jacket of the cord is removed shall be at least 20.5 ft (6.2 m). See 6.5.

### 59 Flexible Cord

59.1 The flexible cord used in power-supply cords for mobile homes shall be Type SOW, SOOW, STW, STOW, STOOW, SEW, SEOW, or SEOOW for mobile-home use containing four No. 6 AWG conductors or four No. 8 AWG conductors or three No. 6 AWG circuit conductors and one No. 8 AWG grounding conductor.

59.1 revised March 16, 2001

59.2 The insulation on the grounding conductor in the cord mentioned in 59.1 shall be green, or green with one or more yellow stripes. The outer surface of the cord shall be marked at intervals no longer than 24 inches (610 mm) with the statement "For mobile-home use: \_\_\_\_ amperes" or "For mobile-home or recreational-vehicle use: \_\_\_\_ amperes." The blank space shall be filled with the appropriate current rating.

### 60 Fittings

60.1 The attachment plug shall have the 3-pole, 4-wire, grounding configuration illustrated in Figure C1.27. The attachment plug shall be molded of butyl rubber, neoprene, or polyvinyl chloride (or other equivalent materials), and shall be so molded to the flexible cord that it adheres tightly to the jacket of the cord at the point where the cord enters the attachment plug (see 60.2). If a right-angle attachment plug is used, the configuration shall be so oriented that the grounding member is the member farthest from the point of cord entry.

60.2 To determine the adhesion between the cord and the body of the fitting, the cord is to be bent sharply to an angle of 90 degrees with the plane of the cord entry and visually examined for openings that might permit the entry of moisture into the body.

60.3 If the visual examination called for in 60.2 cannot verify that acceptable adhesion exists, but there is reason to suspect that an acceptable seal may exist between the cord and the plug at some concealed location within the plug, the representative power-supply cords may be cut apart for examination. The adhesion may be determined to be acceptable if the examination of the inner construction reveals a positive seal at all points around the periphery of the cord.

60.4 A power-supply cord for mobile-home use having No. 6 AWG circuit conductors may have the attachment plug marked 50 A. No other attachment plugs shall be marked with a current rating.

## 61 Rating

61.1 The current rating is:

- a) 40 A for cord containing four No. 8 AWG conductors and
- b) 50 A for cord containing three No. 6 AWG circuit conductors and a No. 6 or 8 AWG grounding conductor.

## NONDETACHABLE POWER-SUPPLY CORDS FOR SPECIAL USE

### 62 General

62.1 These requirements apply to nondetachable power-supply cords intended for special use that incorporate design features (such as special cords and fittings) for a specific application.

62.2 A nondetachable power-supply cord intended for use with a television receiver having a 2-wire polarized attachment plug with a face size larger than that indicated in 25.2.1 shall be marked in accordance with 63.4.

62.3 A special-use nondetachable power-supply cord intended for use with a toy transformer or electric toy shall employ Type SPT-2, NISPT-2, or equivalent or heavier flexible cord with an attachment plug having the distance measured from any point on the blades to the perimeter of the face at least 5/16 inch (7.9 mm).

62.3 revised March 16, 2001

62.4 A 2-conductor nondetachable power-supply cord intended for use with a vacuum cleaner or floor finishing machine that meets the following conditions may have an attachment plug larger than that specified in 25.2.1 and shall be considered for special use.

- a) The flexible cord employed is Type SV, SVO, SVOO, SVT, SVTO, SVTOO, SVE, SVEO, or SVEOO,
- b) The cord employed is at least 15 ft (4.6 m) long, and
- c) The power-supply cord is marked in accordance with 63.6 and 63.7.

62.4 revised March 16, 2001

62.5 A special-use nondetachable power-supply cord intended to be woven in the links of a chain-suspended portable lamp shall:

- a) Be at least 15 feet (4.6 m) long,
- b) Have insulation acceptable for use at 105°C (221°F),
- c) Employ a 2-wire polarized attachment plug (described in Attachment Plug, Section 25) or a 3-wire grounding-type attachment plug,
- d) Be marked to indicate the intended use (see 63.7), and
- e) Be constructed of:



- 1) Type SPT-2, NISPT-2, or heavier flexible cord,
- 2) Type SPT-1, NISPT-1, flexible cord provided with a separate jacket of nylon, or
- 3) Appliance wiring material having No. 36 – 34 AWG (0.013 – 0.020 mm<sup>2</sup>) stranding and complying with the insulation requirements specified in Figure 62.1.

62.5 revised March 16, 2001

**Figure 62.1**  
**Minimum insulation thicknesses for appliance wiring material used in a chain-suspended lamp**

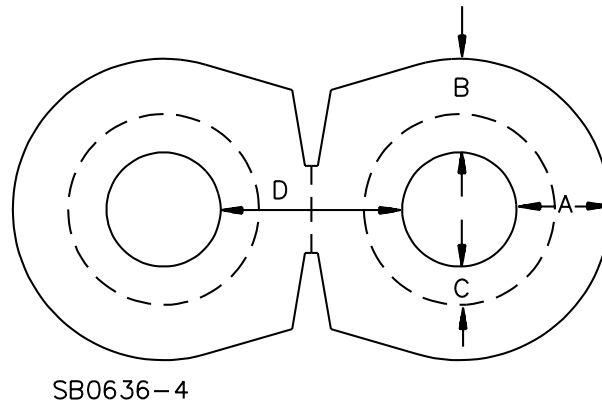

A – Minimum acceptable average thickness away from tear area and outside point – 0.040 inch (1.02 mm)

B – Minimum acceptable thickness at any point before separation– 0.035 inch (0.89 mm)

C – Minimum acceptable thickness at any point after separation– 0.019 inch (0.49 mm)

D – Minimum acceptable distance between copper conductors– 0.060 inch (1.52 mm)

## 63 Markings

63.1 Except as noted in 63.6 and 63.7, each special-use power-supply cord shall be prominently marked to indicate its specific use, electrical rating, and temperature if other than the lowest temperature rating permissible for the particular cord type used.

63.2 Power-supply cords employing Type CXTW, XTW cord, or clock cord, or shaver cord, shall be marked "Power-supply cord having \_\_\_\_ AWG Type \_\_\_\_ special-purpose cord (wire)" on the shipping package where obvious. See note g to Table 44.1. The appropriate wire gauge and type designation is to be inserted in the blank spaces.

63.2 revised March 16, 2001

63.3 A special-use nondetachable power-supply cord intended for use with a television receiver having a 2-wire polarized attachment plug with a face size larger than that indicated in 25.2.1 shall be marked "For use with television receivers" or an equivalent statement.

63.4 A special-use nondetachable power-supply cord intended for use with a toy transformer or electric toy shall be marked "For use with toy transformers or electric toys" or an equivalent statement.

63.5 The special-use power-supply cord for use with a vacuum cleaner or floor finishing machine mentioned in 62.4 shall be marked with "Only for use with vacuum cleaners," or "Only for use with floor finishing machines," or the equivalent.

63.6 The markings for special-use nondetachable power-supply cords indicated in 63.3, 63.4, and 63.5 shall be on the outer surface of the smallest unit package or on a tag inside the smallest unit package, or its equivalent.

63.7 A special-use nondetachable power-supply cord intended to be woven in the links of a chain-suspended portable lamp shall be marked to indicate the intended use on the shipping package where obvious. See 62.5.

## **DETACHABLE POWER-SUPPLY CORDS**

### **64 General**

64.1 If constructed with parallel-type cord, a detachable power-supply cord with a single 15-A, 125-V outlet as shown in Figure C1.1 shall have a maximum length of 20 ft (6.1 m).

64.2 Each detachable power-supply cord of jacketed cord construction with a single 15-A, 125-V outlet as shown in Figure C1.1 shall have a maximum length of 50 ft (15.2 m).

64.3 Detachable power-supply cords using a single 15-A, 125-V outlet as shown in Figure C1.1 shall be marked in accordance with 67.4.

64.4 The overall length of a detachable power-supply cord is to be measured in accordance with 6.4. However, the requirements governing the equipment with which it is intended to be used shall determine the required overall length of the detachable power-supply cord required for each application.

## 65 Fittings

65.1 Each detachable power-supply cord shall have a conductor attached to each blade, pin, or contact in each fitting; and a blade, pin, or contact in each fitting for each conductor.

65.2 Corresponding terminals of line and load fittings of detachable power-supply cord shall be connected to the same conductor of the cord.

65.3 The current rating of a load fitting may be less than 15 A. The voltage rating of the load fitting shall be identical to that of the line fitting.

65.3 revised June 24, 2003

65.4 An outlet fitting shall not be connected in the cord between the end fittings of a detachable power-supply cord.

65.5 Appliance plugs are limited to use on heater cord.

65.6 If a 3-wire outlet fitting having an offset center contact is of other than an American National Standard configuration, it shall be wired according to 65.7.

*Exception: The special-use detachable power-supply cords for replacement use only mentioned in 76.1 need not comply with this requirement.*

65.7 When viewing the face of the load fitting mentioned in 65.6:

- a) With the center contact down, the contact to the right of the center contact shall be connected to the cord conductor that is intended for connection to the grounded conductor of a branch circuit and identified according to 11.2; and
- b) The center contact shall be connected to the cord conductor that is intended for connection to the grounding conductor of a branch circuit and identified according to 11.2.

65.8 A detachable power-supply cord having No. 20 AWG (0.52 mm<sup>2</sup>) conductors, and employing either Appliance Wiring Material constructed in accordance with note m to Table 44.1, or Type SP-1, NISP-1, SPE-1, NISPE-1, SPT-1, or NISPT-1 flexible cord shall:

- a) Have a 2-pole, 2-wire line fitting of the 15 A, 125 V type that complies with 25.1.1 – 25.3.1,
- b) Have a 2-pole, 2-wire load fitting with a 15 A, 125 V configuration other than that shown in Figure C1.1, and
- c) Be provided with overcurrent protection in accordance with Overcurrent Protection, Section 47.

65.8 revised March 16, 2001

## 66 Flexible Cord

66.1 The flexible cord of a detachable power-supply cord shall be one of the cords in Table 44.1.

## 67 Markings

67.1 An individually packaged detachable power-supply cord intended for replacement use shall be marked to indicate its cord type, cord length, conductor size, number of conductors, electrical rating, and temperature rating if other than the lowest temperature rating permissible for the particular cord type used. The markings shall be on the packaging material.

*Exception: Any markings provided on the cord need not be repeated on the packaging.*

67.2 Each detachable power-supply cord rated 50 W or less shall also be marked "For use with hand-held appliances rated 50 watts or less, 125 volts" (or 250 V, depending on the rating of the attachment plug).

67.3 Except as indicated in 67.3.1, detachable power-supply cords intended for shipment to original equipment manufacturers shall have any applicable markings (see General, Section 15, Markings, Section 67; and Markings, Section 79) provided on the outer surface of the shipping carton, or on a tag or the equivalent inside the carton.

Revised 67.3 effective June 24, 2006

67.3.1 The electrical rating shall be marked on each individual detachable power-supply cord unless the ampere rating of the flexible cord is equal to or greater than the ampere rating of the attachment plug.

Added 67.3.1 effective June 24, 2006

67.4 Each detachable power-supply cord with a single 15-A, 125-V outlet as shown in Figure C1.1 shall be permanently marked with the following or equivalent: "CAUTION – To reduce the risk of electric shock do not use as an extension cord. Connect directly to an appliance. Do not connect to a 3-wire grounding-type appliance."

67.5 Each individually packaged detachable power-supply cord intended for replacement use with polarized 15-A, 125-V outlet(s) as shown in Figure C1.1 shall be marked as indicated in 23.12 and 23.13 except that the words "cord set" shall be replaced by "detachable power-supply cord."

67.6 Each individually packaged detachable power-supply cord intended for replacement use with a non-polarized 15-A, 125-V outlet(s), as shown in Figure C1.1, shall be marked with the following information:

CAUTION – This is a NONPOLARIZED power-supply cord and is not for use with appliances that have a polarized plug – one blade wider than the other.

## DETACHABLE POWER-SUPPLY CORDS HAVING APPLIANCE PLUGS

### 68 General

68.1 Each detachable power-supply cord for use with heating appliances shall consist of an attachment plug and an appliance plug (appliance coupler) assembled to a length of heater cord (as described in 66.1) and may include a through-cord switch. See 6.4 and Tables 44.1, 68.1.

**Table 68.1**  
**Pins of appliance and flatiron plugs**

Type and rating of plug that accommodates the pins	Configuration of pins			Dimension of pins	
	Number	Arrangement	Spacing between centers, Inch (mm)	Diameter, Inch (mm)	Length, Inch (mm)
Appliance plug rated 5 A at 250 V and 10 A at 125 V	2	In Line	1/2 (12.7)	0.156 ±0.005 (4.0 ±0.13)	9/16 – 5/8 (14.3 – 15.9)
Flatiron plug rated 5 A at 250 V and 10 A at 125 V	2	In Line	11/16 (17.5)	0.188 ±0.005 (4.8 ±0.13)	3/4 – 7/8 (19.1 – 22.2)
Jumbo appliance plug rated 10 A at 250 V and 15 A at 125 V	2	In Line	1 – 1/16 (27.0)	0.188 ±0.005 (4.8 ±0.13)	3/4 – 7/8 (19.1 – 22.2)
Reversible plug (for two-heat control) rated 10 A at 250 V and 15 A at 125 V <sup>a</sup>	3	In Line	7/8 (22.2)	0.188 ±0.005 (4.8 ±0.13)	3/4 – 7/8 (19.1 – 22.2)
Reversible plug (for two-or three-heat control) rated 10 A at 250 V and 15 A at 125 V <sup>a</sup>	3	One pin at apex of an equilateral triangle	7/8 (22.2)	0.188 ±0.005 (4.8 ±0.13)	3/4 – 7/8 (19.1 – 22.2)

<sup>a</sup> Usually this plug is made without a contact in one of the holes.

68.2 The length of heater cord in a detachable power-supply cord for use with appliances with a heating element shall not be less than 2 ft (0.6 m). See 6.4.

68.2 revised June 24, 2003

68.3 An appliance plug (appliance coupler) that is rated more than 10 A but not more than 15 A shall not be used with a heater cord having conductors smaller than No. 16 AWG.

## DETACHABLE POWER-SUPPLY CORDS HAVING FLATIRON PLUGS

### 69 General

69.1 Each detachable power-supply cord for use with flatirons shall consist of an attachment plug and a flatiron plug (appliance coupler) assembled to a 6 ft (1.8 m) or longer length of heater cord. See 6.4 and Tables 44.1. 68.1.

## DETACHABLE POWER-SUPPLY CORDS FOR APPLIANCES RATED NOT GREATER THAN 50 W

### 70 General

70.1 These requirements apply to detachable power-supply cords intended for use on hand-held appliances rated 50 W or less such as electric shavers, electric scissors, electric combs, or similar hand-held appliances.

### 71 Flexible Cord

71.1 The flexible cord shall be Type TS, TST, TPT, or shaver cord.

*Exception: 2-wire, Type SP-1, NISP-1, SPT-1, NISPT-1, SPE-1, or NISPE-1 flexible cord may be used provided that it employs individual strands of No. 36 AWG.*

71.1 revised March 16, 2001

71.2 The flexible cord shall be at least 5 ft (1.5 m) long but not longer than 8 ft (2.4 m). See 6.4.

### 72 Appliance Coupler

72.1 The appliance coupler shall have only one outlet.

72.2 The 2 contacts in an appliance coupler having tubular contacts with the longitudinal axis parallel shall be as indicated in Table 72.1.

**Table 72.1**  
**Contacts**

Contact	Minimum		Maximum	
	Inch	(mm)	Inch	(mm)
Inside diameter	3/64	(1.2)	5/32	(4.0)
Spacing between centers	3/16	(4.8)	5/16	(7.9)

### **73 Rating**

73.1 A detachable power-supply cord with a load fitting as described in 72.2 shall be rated 50 W, 125 V (or 250 V) depending on the voltage rating of the attachment plug.

### **DETACHABLE POWER-SUPPLY CORDS FOR SPECIAL USE**

#### **74 General**

74.1 These requirements apply to detachable power-supply cords intended for special use that incorporate design features (such as special cords and fittings) for a specific application.

74.2 A detachable power-supply cord intended for special use shall be evaluated with respect to the requirements for detachable power-supply cords and any other items involved with its special use.

#### **75 For Television Receivers**

75.1 A detachable power-supply cord intended for use with a television receiver having a 2-wire polarized attachment plug with a face size larger than that indicated in 25.2.1 shall be marked in accordance with 79.2.

#### **76 Replacement-Use with Nonstandard Polarization**

76.1 A detachable power-supply cord for replacement use only may employ a load fitting (with an offset center contact) that has the contacts arranged in a manner other than that described in 65.6 only if it is marked in accordance with 79.5.

#### **77 For Vacuum Cleaners and Floor-Finishing Machines**

77.1 A 2-conductor detachable power-supply cord intended for use with a vacuum cleaner or floor finishing machine that meets the following conditions may have an attachment plug larger than that specified in 25.2.1 and shall be considered for special use.

- a) The flexible cord employed is Type SV, SVO, SVOO, SVT, SVTO, SVTOO, SVE, SVEO, or SVEOO,
- b) The cord employed is at least 15 ft (4.6 m) long, and
- c) The power-supply cord is marked in accordance with 79.3 and 79.4.

77.1 revised March 16, 2001

## 78 Detachable Power-Supply Cords For Use In Recreational Vehicles

78.1 A detachable power-supply cord for use with a recreational vehicle shall consist of an attachment plug and a length of flexible cord connected to a single outlet cord connector that complies with 78.2 – 78.4. The attachment plug and flexible cord employed shall comply with the requirements in 56.1, 56.2, and 57.1 – 57.4. A detachable power-supply cord for use with a recreational vehicle shall not employ a through-cord switch.

78.2 The length of the finished assembly shall not be less than 30 ft (9.1 m) when measured according to 6.4.

*Exception: The minimum length for a power-supply cord intended for shipment to an OEM is 23 ft (7.0 m).*

78.3 The cord connector shall be of a locking-type, 2-pole, 3-wire or 3-pole, 4-wire grounding configuration identical in ratings to the attachment plug attached to the supply end of the cord. The cord connector shall be molded of butyl rubber, neoprene, or polyvinyl chloride (or other equivalent materials) and shall be molded to the flexible cord so that it adheres tightly to the jacket of the cord at the point at which the cord enters the connector body (see 60.2). If a right-angle body is used, the configuration shall be oriented so that the grounding member is the member farthest from the point of cord entry.

78.4 The cord connector of a detachable power-supply cord having No. 8 AWG circuit conductors shall not be marked with a current rating.

## 79 Markings

79.1 A detachable power-supply cord intended for special use shall be marked to indicate its specific use, electrical rating, and its temperature rating if other than the lowest temperature rating permissible for the particular cord type use.

79.2 A special-use detachable power-supply cord intended for use with a television receiver shall be marked "For use with television receivers" or an equivalent statement when:

- a) The cord is intended for replacement use, or
- b) The cord has the attachment plug mentioned in 75.1.

79.3 The special-use power-supply cord for use with a vacuum cleaner or floor finishing machine mentioned in 77.1 shall be marked with "Only for use with vacuum cleaners," or "Only for use with floor finishing machines," or the equivalent.

79.4 The markings mentioned in 79.2 and 79.3 shall be on the outer surface of the smallest unit package or on a tag inside the smallest unit package, or its equivalent.

79.5 A detachable power-supply cord for replacement use only that employs a load fitting with nonstandard polarization, as described in 76.1, shall be marked as illustrated in Figure 79.1. The marking specified shall be on a tear-resistant tag permanently affixed to the cord within 12 inches (305 mm) of the load fitting.



**Figure 79.1**  
**Example of marking required in 79.5**

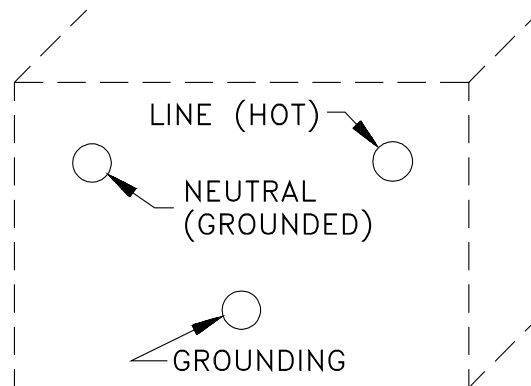

2012

CAUTION – This special-use cord is manufactured as a replacement cord. Its load fitting has the nonstandard polarization shown below:

Make sure this polarization is the same as the polarization of the load fitting on the cord being replaced.

## PERFORMANCE

### 80 Tests on Female Devices

80.1 For tests to be performed on cord connectors and female contacts on current taps, see the Standard for Attachment Plugs and Receptacles, UL 498.

### 81 Conductor Secureness Test

81.1 If a conductor of a flexible cord is connected to an element (male blade or pin or female contact) of a fitting before the element has been assembled to the fitting, the connection shall not break under a pull applied for 1 minute between the element and the conductor before the element has been assembled into the fittings. A pull of 20 lbf (89 N) shall be applied if the conductor is No. 18 AWG or larger in size. If a smaller cord is used, the pull shall be 8 lbf (36 N).

81.2 While the test in 81.1 is being performed, the angle between the element and the cord conductor is to be the same as in the completely assembled fitting. The test shall be performed by using dead weights or, at the manufacturer's option, a power driven tensile testing machine. If a tensile testing machine is used it shall have jaws suitable for holding the specimen and capable of applying the minimum required tensile load to the specimen while separating at a uniform rate not exceeding 1 inch/minute (25.4 mm/min). The machine shall be equipped with a scale from which the load can be read to a value of 0.1 lbf (0.4 N). The accuracy of the scale shall be within  $\pm 2\%$  of the value read, and weights shall be provided for calibrating the machine.

## 82 Security of Blades Test

82.1 If the blades or pins of an attachment plug or current tap of the 2-pole, 2-wire type or of the 2-pole, 3-wire grounding type having one or both power blades  $0.250 \pm 0.010$  inch ( $6.35 \pm 0.25$  mm) wide are not secured within the fitting prior to their being connected to the conductors of the cord, each blade or pin shall be capable of withstanding a pull of 20 lbf (89 N) for 2 minutes without loosening. In a fitting of non-rigid construction a residual displacement of either blade of more than  $3/32$  inch (2.4 mm) measured 2 minutes after the removal of the weight is not acceptable.

82.2 To determine that an attachment plug or current tap complies with 82.1, the fitting is to be wired in the intended manner and then supported on a horizontal steel plate with the blades or pins, or both, projecting downward through a single hole sufficiently just large enough to permit the blades or pins, or both, to pass through it. A weight that exerts 20 lbf (89 N) is to be supported by each blade or pin in succession.

82.3 If parallel blades are involved and the connection of wiring to the blades in the field requires disassembly of the blades from the body so that the secureness of each blade is dependent to some degree on the assembly of the other blade, in addition to the test in 82.2, the 2 blades are also to be tested together. A rigid pin is to be placed in holes that may be drilled in the blade if not provided, and a weight that exerts 20 lbf (89 N) centered between the blades is to be placed on the rigid pin.

## 83 Security of Insulation Test

83.1 A parallel cord that has a nominal insulation thickness less than 0.060 inch (1.52 mm) (such as Types HPN, SP-1, SP-2, SPT-1, SPT-1W, SPT-2, SPT-2W, SPE-1, SPE-2, and XTW), shall be so secured within the fitting that the insulation is kept from slipping away from the terminal connections. Unless the conductor insulation is secured by a knot in the cord inside the fitting, or by an equivalent positive means, the assembly shall be capable of withstanding a pull of 15 lbf (67 N) for 2 minutes. See 83.2.

83.1 revised March 16, 2001

83.2 To determine that the conductor insulation is secured as required in 83.1, the fitting is to be wired as intended with a 6 – 8 inch (152 – 203 mm) length of the flexible cord. The insulation on each conductor of the cord is to be slit parallel to the conductors for a short distance at a point approximately 1 inch (25.4 mm) from its entry into the fitting and all strands of the conductor and the separator (if any) are to be severed at the slit portion. While the fitting is securely held (by its blades in the case of an attachment plug or current tap), a pull of 15 lbf (67 N) is to be applied for a period of 2 minutes at the free end of the cord. Detachment of the insulation from the holding means within the fitting, or baring of the conductors at the entry of the fitting, is considered to be unacceptable.

*Exception: When the conductor insulation on Type HPN flexible cord is seated  $3/8$  inch (9.5 mm) minimum inside the fitting after molding, the length of cord specified in 83.2 is to be 10 – 12 inches (254 – 305 mm) long. The slit in the insulation is to be made approximately 6 inches (152 mm) from the entry into the fitting, and all strands of the conductor and the separator (if any) are to be severed at the slit portion. The 15 lbf (67 N) pull test is to be applied and evaluated as described in 83.2.*

## 84 Strain Relief Test

### 84.1 General

84.1.1 A pull exerted on a cord shall not be transmitted directly to the terminals of a fitting.

*Exception: This test need not be performed on constructions which are subjected to the Abrupt Pull Test in Section 99.*

### 84.2 General-purpose fittings

84.2.1 The assembly of the cord to a fitting other than a flatiron plug, an appliance plug, or a through-cord heating-pad switch shall be capable of withstanding a straight pull of 30 lbf (133 N) if the conductors are No. 18 AWG or larger, and 20 lbf (89 N) if smaller than No. 18 AWG, applied between the fitting and the cord.

*Exception: A through-cord assembly is to be tested cord-to-cord with the switch in between. The detachment of either conductor of the cord from the terminal of the fitting is not acceptable.*

84.2.2 The fitting is to be securely supported by a rigid, flat plate mounted horizontally. The plate is to have a hole just large enough for the supply cord to pass through. A pull of 20 lbf (89 N) or of 30 lbf (133 N), as specified in 84.2.1, is to be applied by means of a weight for 1 minute to the flexible cord, in a direction perpendicular to the plane of the cord-entry hole for a device other than a through-cord switch.

*Exception: A fitting that has the major axis of its blades perpendicular to the plane of the cord-entry opening may be supported by the blades when the test is conducted.*

### 84.3 Investigation of strain relief clamps requiring supplementary mechanical protection

84.3.1 Each of six representative complete strain relief assemblies is to be used for this test. Each of three assemblies shall be tested unaged and each of three assemblies after aging 7 days in a forced-draft circulating-air oven at  $90.0 \pm 2.0^{\circ}\text{C}$  ( $194.0 \pm 3.6^{\circ}\text{F}$ ). Each assembly shall be subjected to a dielectric voltage-withstand test as required for the device, followed by a 30 lbf (133 N) strain-relief test for 1 minute, and then again subjected to the dielectric voltage-withstand test for 1 minute. The dielectric voltage-withstand test shall be conducted both between conductors and between metal parts of the clamp and the conductors connected together. In no case shall there be any dielectric breakdown or arc-over, and the strain-relief means shall prevent any movement of the cord that might transmit the strain to the wiring terminals of the device. Prior to the test of the oven-aged assemblies, these assemblies are to be visibly examined and show no evidence of damage to the cord insulation.

#### 84.4 Joints and general-purpose fittings

84.4.1 A joint in the flexible cord shall be capable of withstanding a straight pull of 30 lbf (133 N) applied between the joint and the cord.

84.4.2 To determine that a joint complies with 84.4.1, the joint is to be securely supported by a rigid, flat plate mounted horizontally. The plate is to have a hole just large enough for the supply cord to pass through. A pull of 30 lbf (133 N) as specified in 84.4.1 is to be applied by means of a weight for 1 minute to the flexible cord in a direction perpendicular to the plane of the cord-entry hole. The detachment of either conductor of the cord from the termination at the joint is not acceptable.

#### 84.5 Flatiron and appliance plugs

84.5.1 The strain relief provided in a flatiron or appliance plug shall keep a stress applied to a cord from being transmitted to the plug terminals when the assembly is tested as described in 84.5.2.

84.5.2 The plug is to be wired as received, except that the cord conductors are to be disconnected from the female contacts of the plug, and a pull of 35 lbf (156 N) is to be applied for 1 minute between the cord and the plug. The force may be exerted by any convenient means, but is not to be applied suddenly. Where there is slack between the strain-relief point and the terminal connection, a slight amount of slippage at the point where the strain relief itself is applied is not objectionable, but the results are not acceptable if the ends of the cord are pulled away from the terminal cut.

84.5.3 A flatiron or appliance plug wired with cord of round cross-section shall be so constructed that the assembly is capable of withstanding a torque of 3 lbf-in (0.34 N·m) when tested as described in 84.5.4 and 84.5.5.

84.5.4 The plug is to be wired as received, except that the cord conductors are to be disconnected from the contacts. The torque is to be applied to the assembly by any method at a point close to the guard that does not cause any compression of a spring or rubber nozzle. During the test, there is to be no pull on the cord and the axis of the cord is to coincide with the main axis of the plug. The duration of the test is to be 1 minute. If the cord twists more than 90 degrees within the plug body at the point of separation of the 2 conductors, the strain-relief means is not acceptable.

84.5.5 The illustration in Figure 84.1 shows a device acceptable for making the torsion test. The cord is to be gripped in a clamp at the end of the shaft, and the plug is then to be twisted slowly by hand until the weight is lifted clear of its support or until failure occurs. With the weight hanging freely, the applied torque is to be 3 lbf-in (0.34 N·m).

**Figure 84.1**  
**Torque testing equipment**

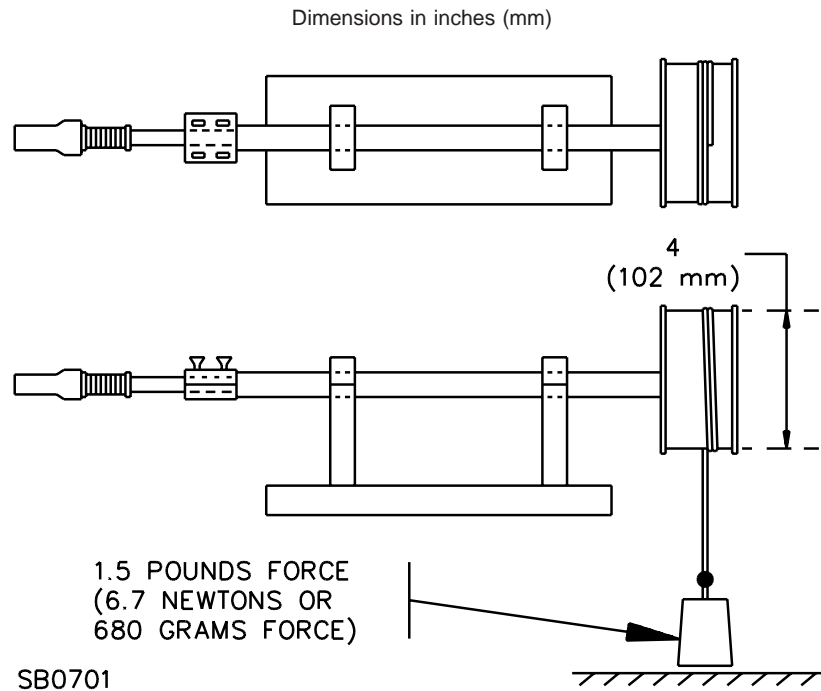

#### 84.6 Through-cord heating-pad switches

84.6.1 Each through-cord heating-pad switch shall be assembled with a means to provide strain relief unless all connections in the switch (except for a soldered joint in a slack portion of the through conductor) are riveted or welded, or unless such connections are made by means of eyelets, pressure wire connectors with closed-loop tangs, soldered loops in the conductors, or soldered joints where mechanical security is provided without depending upon the joint. Terminal binding screws shall not unthread completely when the switch is assembled.

84.6.2 The connections, strain relief, or the combination thereof in a through-cord heating-pad switch shall be capable of withstanding for 1 minute a straight pull of 50 lbf (222 N) when tested as described in 84.6.3.

84.6.3 To determine that the switch connections comply with 84.6.2, the cord is to be gripped with a clamp on each side of the switch. One clamp is to be held securely while the pull is applied to the other. Unless all connections in the switch are made by one of the means described in 84.6.1, the cord conductors are to be severed near the switch terminals prior to the application of the pull. If the ends of the conductor, after having been severed, are pulled away from the terminals by the application of the force, the results of the test are unacceptable. If the conductors were not severed prior to the test, the results are unacceptable if there is any breakage of the conductors or disruption of connections in the switch as a result of the application of the force.

## 85 Strain Relief Test – Range and Dryer Power-Supply Cord Kits

85.1 The strain relief means provided with a range or dryer power-supply cord kit shall be tested as described in 85.2 and 85.3. As a result of these tests:

- a) There shall be no damage to the cord insulation or jacket,
- b) There shall be no movement of the cord with respect to the strain relief such that stress would have resulted on the internal connections, and
- c) The cord shall not contact the edge of the hole in the test plate.

85.2 Three previously untested representative range or dryer power-supply cord kit of the strain-relief means are each to be assembled to a power-supply cord using the installation instructions provided and then mounted in a round hole in the center of a 3/64 inch (1.2 mm) thick sheet metal test plate having a length, and width, of 12 inches (305 mm). The diameter of the mounting hole is to be the applicable maximum connection opening diameter specified in Table 85.1. The test plates are to be rigidly supported, one in each of the following positions:

- a) Horizontal,
- b) Vertical with the major cross-sectional axis of the power-cord in a horizontal position, and
- c) Vertical with the major cross-sectional axis of the power-supply cord in a vertical position.

A 35 lb (15.9 kg) weight to is be suspended from the external part of each power-supply cord for 1 minute.

*Exception: When testing a round power-supply cord, the two tests with the test plate in the vertical position may be combined into one test with the strain relief arranged in the most adverse position.*

85.3 The entire test described in 85.2 is to be repeated on three previously untested representative range or dryer power-supply cord kit that are assembled and mounted in a hole having the applicable minimum connection opening diameter specified in Table 85.1.

**Table 85.1**  
**Range and dryer power-supply cords**

Number, size and use of conductors	Current rating, amperes	Voltage rating, volts	Plug type and configuration	Diameter of connection opening, Inches (mm)	
				Minimum	Maximum
2 No. 10 AWG unidentified circuit and 1 No. 10 AWG grounded circuit	30	125/250	3 pole, 3 wire, Figure 161.18 (10-30P)	1.094 (27.79)	1.140 (28.96)
2 No. 10 AWG unidentified circuit and 1 No. 10 AWG grounded circuit and 1 No. 10 AWG grounding	30	125/250	3 pole, 4 wire, grounding Figure 161.26 (14-30P)	1.094 (27.79)	1.140 (28.96)
2 No. 8 AWG unidentified circuit and 1 No. 10 AWG grounded circuit	40	125/250	3 pole, 3 wire, Figure 161.19 (10-50P)	1.360 (34.54)	1.406 (35.71)
2 No. 8 AWG unidentified circuit and 1 No. 10 AWG grounded circuit and 1 No. 10 AWG grounding	40	125/250	3 pole, 4 wire, grounding Figure 161.27 (14-50P)	1.360 (34.54)	1.406 (35.71)
2 No. 6 AWG unidentified circuit and 1 No. 8 AWG grounded circuit	50, marked for use with 1-3/8 inch opening	125/250	3 pole, 3 wire, Figure 161.19 (10-50P)	1.360 (34.54)	1.406 (35.71)
2 No. 6 AWG unidentified circuit and 1 No. 8 AWG grounded circuit and 1 No. 8 AWG grounding	50, marked for use with 1-3/8 inch opening	125/250	3 pole, 4 wire, grounding Figure 161.27 (14-50P)	1.360 (34.54)	1.406 (35.71)
2 No. 6 AWG unidentified circuit and 1 No. 8 AWG grounded circuit	50, marked for use with 1-3/4 inch opening	125/250	3 pole, 3 wire, Figure 161.19 (10-50P)	1.719 (43.66)	1.765 (44.83)
2 No. 6 AWG unidentified circuit and 1 No. 8 AWG grounded circuit and 1 No. 8 AWG grounding	50, marked for use with 1-3/4 inch opening	125/250	3 pole, 4 wire, grounding Figure 161.27 (14-50P)	1.719 (43.66)	1.765 (44.83)

## 86 Push-Back Test for Range and Dryer Power-Supply Cord Kits

86.1 The strain relief means provided with a range or dryer power-supply cord kit shall prevent the flexible cord from being pushed into the cord mounting opening in an appliance.

86.2 For testing purposes, the metal plate used for the Strain Relief Test-Range and Dryer Power-Supply Cord Kits, Section 85, may be used to simulate the cord mounting opening in the appliance.

86.3 The flexible cord is to be held by the fingers 1 inch (25.4 mm) from the point where the cord emerges from the cord mounting opening. It is to be pushed back with casual force (see Figure 86.1). The force is to be applied until the cord is buckled but in no case shall the force applied exceed 6 lbf (26.7 N).

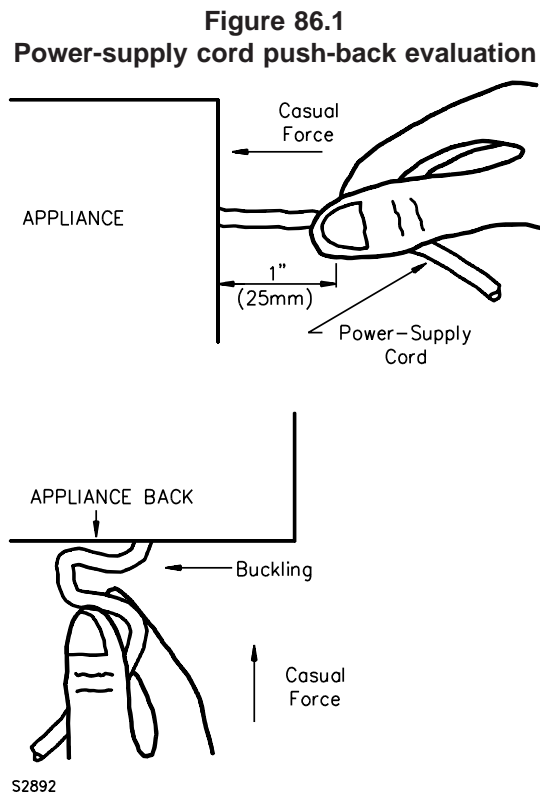

## 87 Temperature Test

### 87.1 General

87.1.1 The blade of a male fitting shall be capable of carrying continuously, without a temperature rise of more than 30°C (54°F), a current equal to the ampacity of the cord, but not greater than the maximum current for which the plug is rated. If the product employs a fuse, it shall be tested with the fuse in place and the fuse shall remain intact following the test.



87.1.2 To determine that a male fitting complies with 87.1.1, the blades of the male fitting are to be connected to each other by means of a short length (not more than 1-1/2 inches or 38 mm) of copper wire with one end soldered to each blade. The wire is to be No. 14 AWG if the rated ampacity of the cord is not more than 18 A, and is to be No. 8 AWG for a cord that is rated for higher ampacity. With the assembly carrying a current equal to the acceptable ampacity of the cord (either direct current or alternating current), temperatures are to be measured by means of thermocouples on the blades at the plane of the face of the male fitting.

## 87.2 Joints

87.2.1 A joint in an adapter cord set shall be capable of carrying continuously, without a temperature rise of more than 30°C (54°F), a current equal to the rating of the adapter cord set.

87.2.2 To determine that a joint complies with 87.2.1, the adapter cord set is to be caused to carry a current equal to the rating of the adapter cord set; temperatures are to be measured by means of thermocouples placed in contact with the joint adjacent to the conductor.

## 88 Dielectric Voltage-Withstand Tests

88.1 Each cord set or power-supply cord shall be capable of withstanding without breakdown for a period of 1 minute, before and after conducting the Crushing Test, Section 91, and the Impact Resistance Tests, Section 92, the application of a 60-Hz potential of 1250 V between any two conductors (see 88.2).

88.2 Bared ends of a power-supply cord may be separated from each other while the test in 88.1 is being conducted. The test is to be repeated until each conductor has been tested with respect to every other conductor.

88.3 The test potential is to be supplied from a 500 VA or larger capacity testing transformer whose output is essentially sinusoidal and can be varied. The applied potential is to be increased from zero until the required test voltage is reached, and is to be held at that voltage for 1 minute. The increase in the applied potential is to be at a substantially uniform rate and as rapid as is consistent with its value being correctly indicated by a voltmeter.

*Exception: The output of the test transformer may be less than 500 VA if a voltmeter is used in the output circuit to directly measure the applied potential.*

88.4 An attachment plug with solid blades of maximum length is to be fully inserted into a cord connector or current tap when the test described in 88.1 is conducted.

## 89 Insulation Resistance Test

89.1 The insulation resistance of a fitting shall not be less than 100 megohms between:

- a) Live parts of opposite polarity,
- b) Live parts and dead metal parts that are exposed to contact by persons or that may be grounded in service, and
- c) Live parts and any surface of insulating material that is exposed to contact by persons or that may be in contact with ground in service.

89.2 To determine compliance with 89.1, the insulation resistance is to be measured by a megohmmeter which has an open-circuit output of 500 V or by equivalent equipment.

89.3 The use of a megohmmeter between live parts requires no special clarification or instruction. However, in measuring insulation resistance to the surface of an insulating material, it is necessary to apply the electrode to the insulating material as described in 89.4.

89.4 A quantity of No. 7 lead drop shot [approximate diameter 0.10 inch (2.5 mm)] is to be placed in a container which is open at the top. After cord holes or other openings through which the shot can enter have been plugged carefully with a high-resistance insulating material, the fitting is to be immersed in the shot so that the shot serves as an electrode in contact with the surface to which the test is to be applied.

89.5 All rubber parts are to be kept for at least 48 hours at room temperature before being subjected to the test mentioned in 89.1 – 89.4.

## 90 Accelerated Aging Tests

### 90.1 Rubber compounds

90.1.1 Molded rubber for the insulation of a joint or a molded rubber device shall show no apparent deterioration and shall show no greater change in hardness than 10 numbers after being tested as described in 90.1.2 – 90.1.4.

90.1.2 If possible, the molded rubber joint or device is to be used complete. The hardness of the rubber is to be determined as the average of 5 readings with a gauge such as the Rex Hardness Gauge or the Shore Durometer. The joint or device is then to be placed for 70 hours in a full-draft circulating-air oven at a temperature of  $100 \pm 2^{\circ}\text{C}$  ( $212 \pm 3.6^{\circ}\text{F}$ ). The joint or device is to be allowed to rest at room temperature for 4 or more hours after removal from the oven. The hardness is to be determined again as the average of 5 readings. The difference between the average original hardness reading and the average reading taken after oven aging is the change in hardness.

90.1.3 Following the oven aging mentioned in 90.1.1 and 90.1.2, a molded rubber joint or device shall be capable of withstanding the pull test described in 84.4.1.

90.1.4 The accelerated-aging tests described in 90.1.1 – 90.1.3 are to be made on specimens of each color of rubber and on specimens for each basic rubber compound employed for the joint or device.

## 90.2 PVC compounds

90.2.1 A joint having a body of molded polyvinyl chloride or a copolymer thereof shall show no crack, discoloration, or other visible signs of deterioration as the result of exposure for 96 hours in a full-draft circulating-air oven at a temperature of  $100.0 \pm 1.0^{\circ}\text{C}$  ( $212.0 \pm 1.8^{\circ}\text{F}$ ).

## 91 Crushing Test

91.1 A molded-on line fitting of the 2-pole, 2- or 3-wire type having parallel or tandem blades and contacts and rated 15 A, 125 or 250 V shall be capable of withstanding for 1 minute a crushing effort of 75 lbf (334 N) applied in any direction at right angles to its major axis. There shall not be any cracking or breaking to the extent that:

- a) The fitting becomes unfit for use, or
- b) Live parts become exposed to unintentional contact.

The fitting shall be conditioned in a circulating-air oven for 7 days at  $90.0 \pm 1.0^{\circ}\text{C}$  ( $194.0 \pm 1.8^{\circ}\text{F}$ ) and then cooled to room temperature before being subjected to the crushing test. See also 92.1.

91.2 Any testing equipment that can apply a steady pressure of 75 lbf (334 N) to the fitting may be employed. The fitting is to be tested between two 1/2 inch (13 mm) or thicker parallel flat maple blocks. Care is to be taken that the crushing force is not applied suddenly.

*Exception: Bodies molded of solid polyvinyl chloride, TPE, or thermoset need not be tested.*

91.2 revised March 16, 2001

## 92 Impact Resistance Test

92.1 When subjected to the impact test described in 92.2 each molded-on fitting shall not crack or break to the extent that it becomes unfit for use, or live parts become exposed to unintentional contact. The fitting shall be conditioned in a circulating-air oven for 7 days at  $90.0 \pm 1.0^{\circ}\text{C}$  ( $194.0 \pm 1.8^{\circ}\text{F}$ ) and then cooled to room temperature before being subjected to the impact test.

*Exception: Bodies molded of solid polyvinyl chloride, TPE, or thermoset need not be tested.*

92.1 revised March 16, 2001

92.2 Each of six representative molded-on fittings is to be tested. Each fitting is to be wired with No. 18 AWG, Type HPD cord (see 92.3), the free end of which is to be passed through and knotted behind a bushing located at the point labeled A in Figure 92.1. The cord is to be free to rotate in the bushing. Initially, the cord and fitting are to hang freely and rest in the position labeled "1" in Figure 92.1 against the vertical face of the block C, which is a piece of maple 1.5 – 2 inches (38 – 51 mm) thick that is sufficiently high and wide to keep a fitting from striking near one of the edges of the block. The grain is to run vertically. The plane of the face of block C is to contain point A. The distance from the bushing to the contact end of the fitting is to be 45 inches (1143 mm). Lifting member B of the machine is to lift the fitting by the cord to the position labeled "2" in Figure 92.1. At this point, the edge of member B farthest from

point A is to be approximately 38 inches (965 mm) from the plane of the face of block C on a line normal to the plane A. The cord is to be released from member B and the fitting is to fall freely to strike block C. The machine is to repeat the operation continuously for 1000 cycles.

**Figure 92.1**  
**Impact resistance test**

Figure 92.1 revised June 24, 2003

All dimensions are in inches (mm)

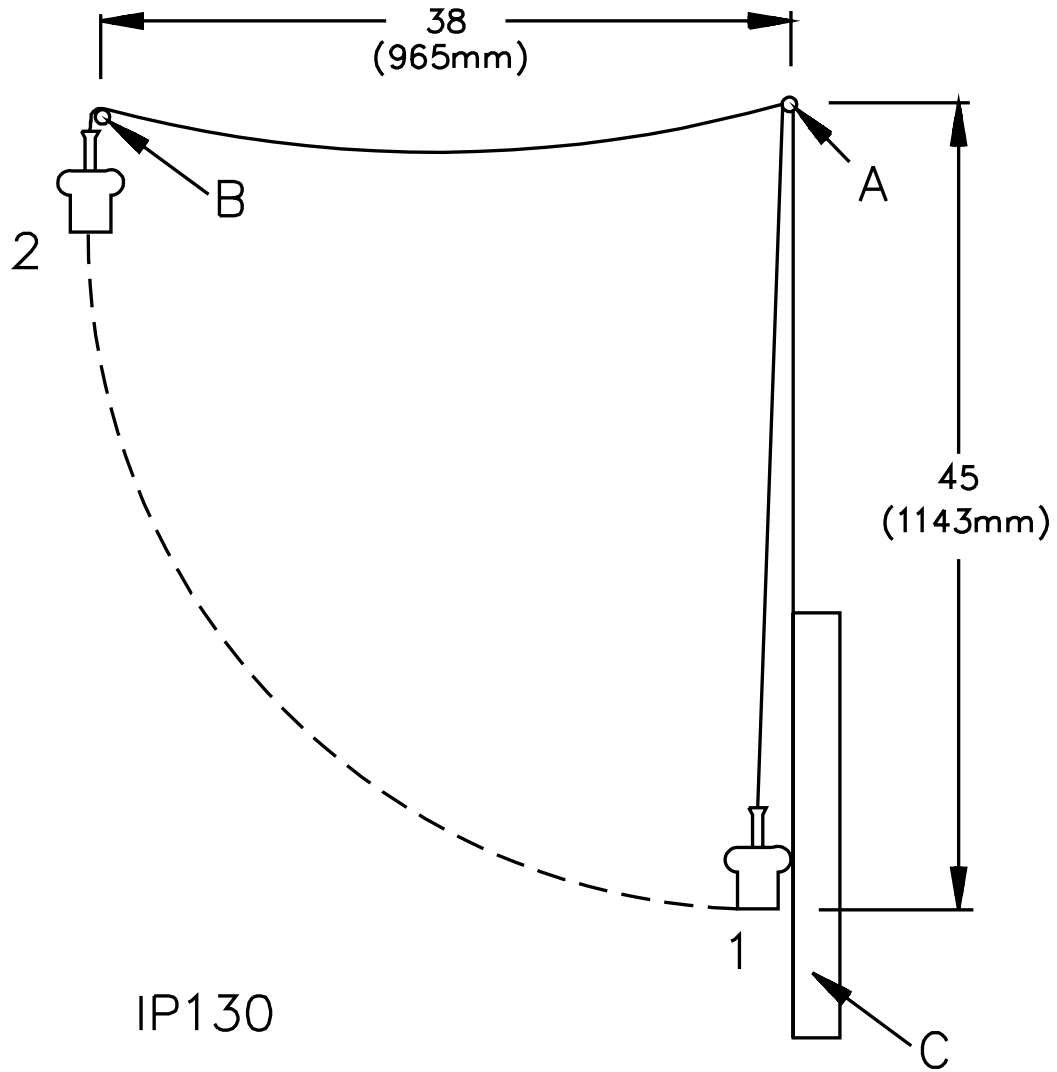

IP130

A – Supporting bushing

B – Lifting Member

C – Maple block

1 and 2 – See 92.2

92.3 If the cord provided is other than Type HPD, the cord is to be cut off so that the length extending from the body of the fittings does not exceed 1-1/2 inches (38 mm). The short length of cord is then to be attached to a length of Type HPD cord by binding or other similar means and the complete assembly mounted on the test machine.

### **93 Improper Insertion Test**

93.1 To determine compliance with 9.3, each outlet device shall acceptably obstruct the attempted insertion of the test blades illustrated in Figure 93.1, when tested as described in 93.2 and 93.3.

93.2 Each of 12 cord connectors is to be tested while being supported on a flat steel plate. Rigid spacing materials may be used to support a cord connector that because of its shape does not lie flat on the steel plate, provided that by doing so, pressure is not exerted against the cord connector that will influence test results. The test blades shall be supported and centered above the smaller contact slot of the cord connector being tested.

93.3 Each test blade is to be inserted into the smaller contact slot with a force that is to be gradually increased from zero to a 35 lbf (156 N). The force is to be maintained for 1 minute. Each of six cord connectors is to be tested using test blade 1, and six using test blade 2. In each case, the test blades shall be obstructed to the extent that they do not make electrical contact with the device contact relating to the smaller slot.

### **94 Attachment Plug Grip Test**

94.1 The attachment plug shall be tested as described in 94.2 – 94.9 to determine compliance with 25.3.1.

94.2 Prior to testing, the reference plug shown in Figure 94.1 is to be cleaned with a metal cleaner. The reference plug, the representative plugs, and the hands of each individual conducting the test are to be washed with soap and water, rinsed, and then dried.

94.3 The test apparatus is to consist of a spring scale equipped with a means to securely attach both the reference plug and test representative plugs in a manner that prevents rotational movement during pulls. A simulated face plate, having an opening for the plug blades, is to be secured to the movable member. The mounting arrangement for the plug under test is to be such that the face of the plug is flush with the face plate. A typical apparatus is shown in Figure 94.2.

94.4 A representative plug, with cord cut off close to the plug, is to be securely attached to the test apparatus. The individual performing the test is to grip the representative plug with either hand in a manner intended to apply the maximum pull force. A steady straight pull is to be applied until the plug pulls free from the individual's hand. The individual applying the force is not to view the force indicator during the pull. The maximum pull force applied during the pull is to be recorded. Immediately following the pull test, the reference plug is to be attached to the test apparatus and a comparison pull made using the same hand. The maximum pull force is to be recorded. The ratio of the force for the representative plug to the reference plug is to be calculated and recorded.

Figure 93.1  
Improper insertion test blades

TEST BLADE 1

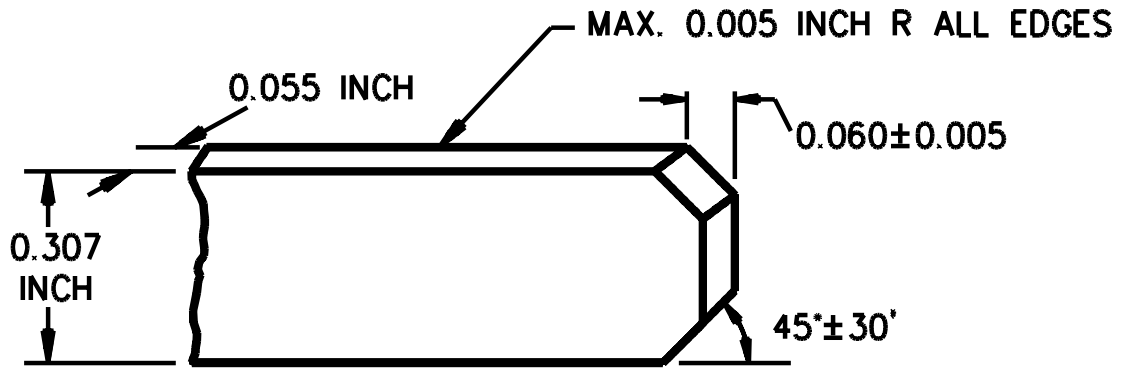

MATERIAL: TOOL STEEL

TEST BLADE 2

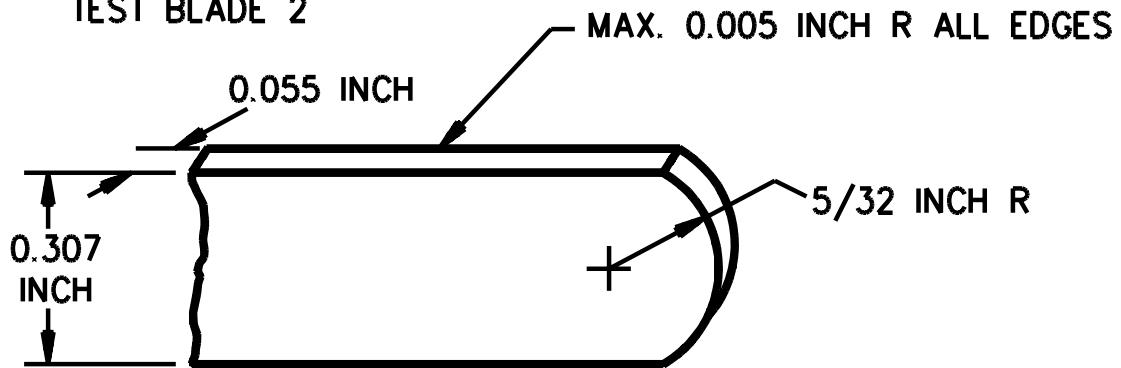

SB1889

MATERIAL: TOOL STEEL

Inch	0.005	0.055	.060	5/32	0.307
mm	0.13	1.40	1.52	4.0	7.80

Figure 94.1  
Reference plug

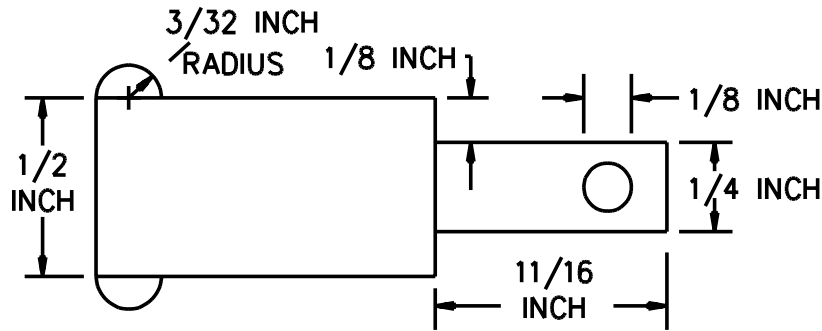

MATERIAL - BRASS

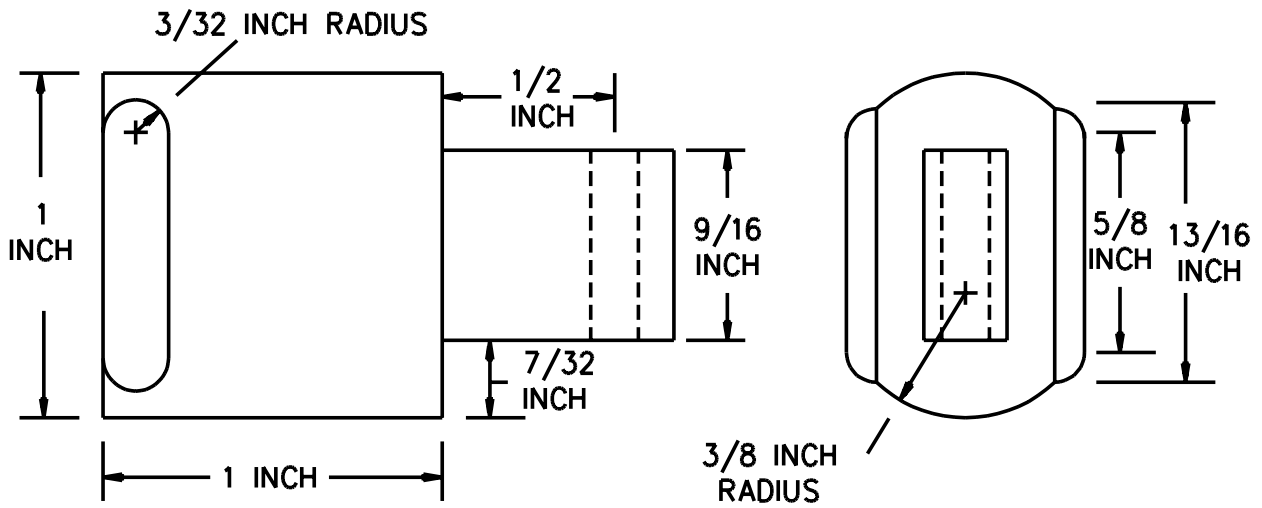

SB1846

Inch	3/32	1/8	7/32	1/4	3/8	1/2
mm	2.4	3.2	5.6	6.4	9.5	12.7

Inch	9/16	5/8	11/16	13/16	1.0
mm	14.3	15.9	17.5	20.6	25.4



Figure 94.2  
Typical test apparatus  
TOP VIEW

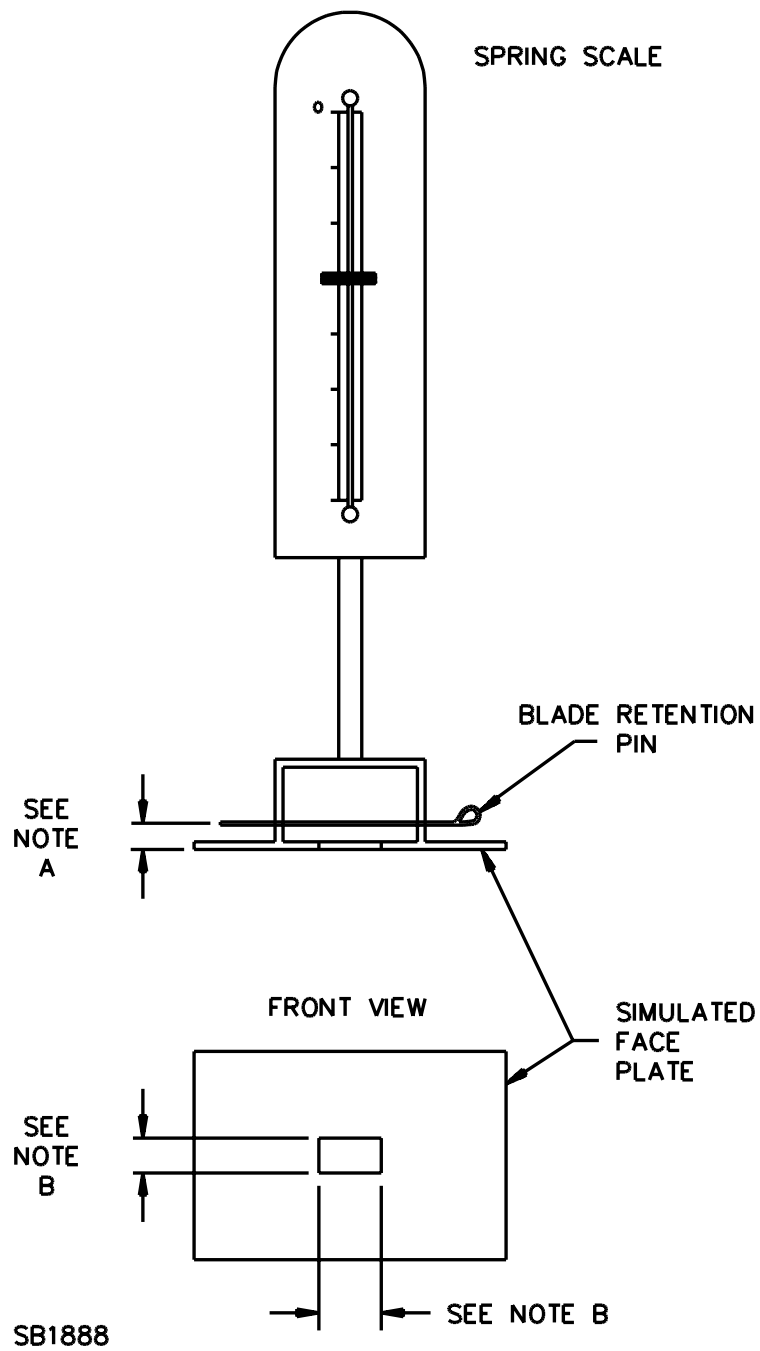

Note A – Retaining pin through blades spaced to keep plug close to plate

Note B – Large enough for blades to pass through

94.5 The comparison pull procedure described in 94.4 is to be repeated on the same representative plug an additional two times by the same individual. The ratio for each pair of pulls (test/reference) is to be calculated and recorded.

94.6 Each individual is to test each of three representative plugs as described in 94.4 and 94.5 with the ratio for each pair of pulls being calculated and recorded for all three plugs.

94.7 Two additional individuals are to test each of three representative plugs (for a total of 9 comparison pulls per individual), as described in 94.4, 94.5, and 94.6. The ratio for each pair of pulls (test/reference) is to be calculated and recorded.

94.8 The results are considered acceptable if all of the following conditions are met:

- a) The ratio for each pair of pulls (test/reference) is 0.55 or larger for at least two pulls (of the three pulls performed) on each representative plug,
- b) At least two (of the three) representative plugs tested by each individual comply with item (a), and
- c) At least two individual's test results comply with item (b).

94.9 If only one individual obtains results that comply with item (b) of 94.8, at the manufacturer's request, two individuals not previously involved in testing may test each of three representative plugs as described in 94.4, 94.5, and 94.6. The results are considered acceptable if both individual's test results comply with items (a) and (b) of 94.8.

## 95 Blade Pull Test at Elevated Temperature

95.1 Following the oven conditioning described in this section, an attachment plug or current tap shall be capable of withstanding the 10 lbf (44.5 N) pull indicated without displacing either blade from its original position in the molded body by more than 1/16 inch (1.6 mm).

95.2 Each of six representative attachment plugs or current taps molded to a length of cord no more than 6 inches (152.4 mm) long is to have a line scribed on both sides and both edges of the blades to indicate the point where the blade enters the device body. Each attachment plug or current tap is then to be securely mounted so that the line blades are positioned downward through a circular hole (diameter just large enough to allow the line blades and any grounding pin to pass through) in a 1/4 inch (6.4 mm) thick steel plate mounted horizontally within an air circulating oven that has been heated to 60°C (140°F). After the fittings have been positioned, a weight that exerts 10 lbf (44.5 N) is to be attached to each of the individual line blades. The oven is then to be maintained at 60°C (140°F) for 4 hours after which the weights are to be removed and the attachment plugs or current taps taken from the oven and allowed to cool to room temperature. The displacement of the blades from their original position shall then be determined as described in 95.4.

*Exception: To facilitate the placement of test weights within the test chamber, testing may instead be accomplished by exerting the pull on just one blade of each attachment plug or current tap. Of the 12 attachment plugs or current taps which would be required, 6 shall be tested using the right-hand blade and the remaining 6 tested using the left-hand blade.*

95.3 The circular hole mentioned in 95.2 should be the smallest diameter capable of accommodating the line blades and, if the plug is of a grounding type, any grounding pin. For example, a hole sized to accommodate a 3-wire, 15-A, 125-V plug cannot be used to test a 2-wire, 15-A, 125-V plug since the opening for the blades and grounding pin of the 3-wire plug would be larger than the minimum size necessary for the blades of the 2-wire plug to just pass through.

95.4 The distance from the scribed lines, on each of the sides and both edges of the blades, to the face is to be measured after the thermal conditioning. The average of the four measurements for each blade shall be used to determine compliance with the 1/16 inch (1.6 mm) maximum displacement requirement.

## 96 Flexing Test – Devices Employing Parallel Cords of Integral or Nonintegral Construction

96.1 A molded-on attachment plug, cord connector, load fitting, or current tap of a cord set or power-supply cord employing an integral or nonintegral parallel-type flexible cord having No. 18, 16, or 14 AWG conductors shall be capable of withstanding a minimum of 2,500 cycles when tested as described in this section.

*Exception: The flexing test is not required for molded-on fittings limited to use on cord sets:*

*a) Employing Type SP-2, NISP-2, SPT-2, NISPT-2, SPE-2, NISPE-2, SP-3, SPT-3, or SPE-3 flexible cord having conductors of 30 AWG stranding and*

*b) Marked in accordance with 23.3.*

96.1 revised March 16, 2001

96.2 Six fittings molded to 20 inch (508 mm) lengths of flexible cord are required.

96.3 Each representative device is to be secured to the flexing apparatus so that the flexible cord assumes the natural bend permitted by the fitting construction. The major axis of any right cross section of the cord is to be parallel to the longitudinal axis of the rotation shaft of the test fixture (see Section A-A in Figure 96.1) so as to allow the cord to flex without any twisting of the parallel conductors. The test weights are to be as follows:

a) For SPT types (SP-1, NISP-1, SPT-1, NISPT-1, SPE-1, NISPE-1, SP-2, NISP-2, SPT-2, NISPT-2, SPE-2, NISPE-2, SP-3, SPT-3, SPE-3 and appliance wiring material in accordance with 62.5) 4 ounces (113 g) and

b) For Type HPN, 10 ounces (284 g).

96.3 revised March 16, 2001

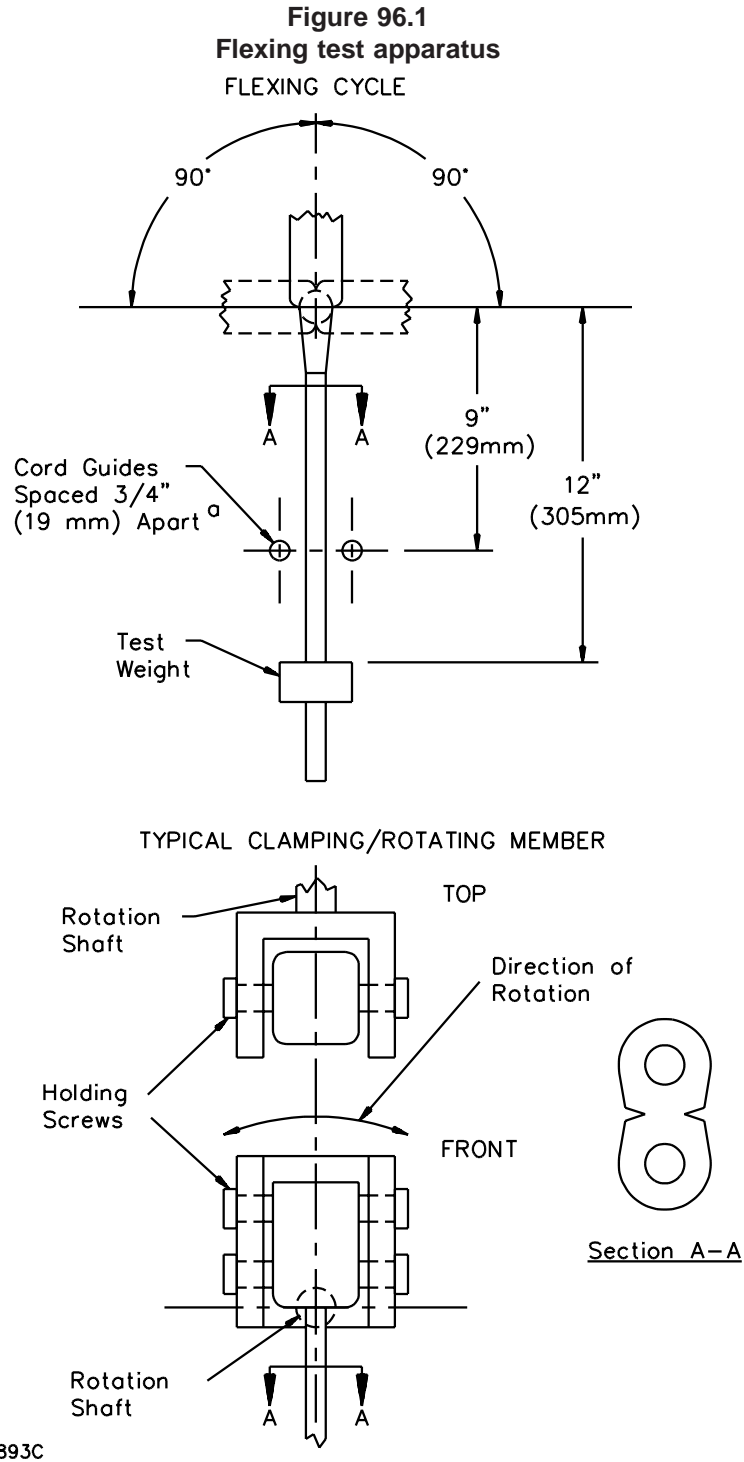

<sup>a</sup> Cord guides are used only to control oscillation of the flexible cord during testing and can therefore be adjusted, if necessary, so that the cord does not contact the guides in a manner that could increase the degree of bend present at its entry to the fitting during the test.

96.4 Each molded-on representative device is to be secured in the jaws of the flexing machine so that the point of cord exit is at the center of rotation. The rotating jaws are to be adjusted to rotate to an angle of 90° to each side of the centered position. At the centered position, the cord is to hang vertically and the weight, selected in accordance with 96.3, attached to each cord approximately 12 inches (305 mm) from the point of rotation. See Figure 96.1.

96.5 Each representative device is to be subjected to complete flexing cycles until a conductor in each device has opened (as determined by a continuously-monitoring detection circuit), or until 2,500 cycles is reached, whichever comes first. A flexing cycle consists of: rotation of the jaws from the vertical (centered) position until 90° to one side, back past the vertical position until 90° to the other side, and back to the vertical (centered) position. The rate of testing shall be 10 cycles per minute.

## 97 Low-Temperature Insertion Test

97.1 Each outlet of a cord connector of an outdoor-use cord set employing one of the 2-pole, 2- or 3-wire, 15 or 20-A, 125-V configurations shown in Figures C1.1, C1.5, or C1.6, shall be capable of being mated with a solid-blade attachment plug, of the mating configuration, at a temperature of  $\text{minus } 20.0 \pm 1^\circ\text{C}$  ( $\text{minus } 4 \pm 1.8^\circ\text{F}$ ) without resulting in a gap, between the faces of the mated fittings, exceeding 0.079 inch (2 mm).

97.1 revised March 16, 2001

97.2 Each of six representative cord connectors, assembled onto a 12 inch (305 mm) length of flexible cord, and six representative mating attachment plugs, is to be conditioned at a temperature of  $\text{minus } 20.0 \pm 1^\circ\text{C}$  ( $\text{minus } 4 \pm 1.8^\circ\text{F}$ ) for 4 hours.

97.3 Following the four-hour conditioning period, one cord connector and one mating attachment plug are to be taken from the conditioning chamber, and immediately upon removal, the fittings are to be mated with an insertion force of 40 lbf (178 N) applied for a maximum of 1 minute. This procedure is to be repeated five additional times using a previously unused plug and connector for each consecutive mating, until all connectors have been tested.

97.4 With cord connectors having multiple outlets, one random outlet of each cord connector shall be subjected to the insertions described in 97.3.

97.4 revised March 16, 2001

## 98 Random Drop Test

98.1 After completion of the test described in 98.2, no outlet face of a cord connector employed on an outdoor-use cord set shall land face up or face down upon coming to rest on a horizontal surface.

98.2 Each of three representative outdoor-use cord sets is to be grasped with one hand on the cord connector and the other hand on the flexible cord or attachment plug body, leaving 6 ft (1.8 m) of slack in the flexible cord. Each cord set is to be dropped three times through a distance of 3 ft (0.91 m) to strike a concrete floor in the positions most likely to produce adverse results. In each drop, the cord connector is to strike the surface in a position different from those in the other two drops.

## 99 Abrupt Pull Test

### 99.1 Cords employing a grounding conductor

99.1.1 Molded-on attachment plugs and the male portion of molded-on current taps used on cord sets and power-supply cords employing a grounding conductor shall be resistant to physical abuse so as to acceptably withstand the test described in 99.1.2 – 99.1.6 without resulting in a discontinuity in any conductor or connection as a result of 5 impacts and the number of impacts needed to cause a break in the grounding circuit shall be not less than the number of impacts required to break any of the line circuits – up to a maximum of 25 impacts. Subsequent to that testing, the grounding conductor shall remain functional to the extent that it can carry a 40 A current for 2 minutes as described in 99.1.7.

*Exception: The abrupt pull test is not required for attachment plugs and current taps molded onto No. 10 AWG and larger flexible cords.*

99.1.2 Each of six representative assemblies consisting of an attachment plug or current tap molded onto a 12 inch (305 mm) length of flexible cord is necessary for the test. Assemblies are to be tested in the ground pin up position except for right angle plugs which are to be tested only in the cord down position.

99.1.3 The molded-on fitting shall be securely attached by the blades to the mounting plate of the test apparatus shown in Figure 99.1 and the plate positioned so that the fitting is pointing downward at an angle of 45° to the vertical.

Figure 99.1  
Abrupt pull test apparatus

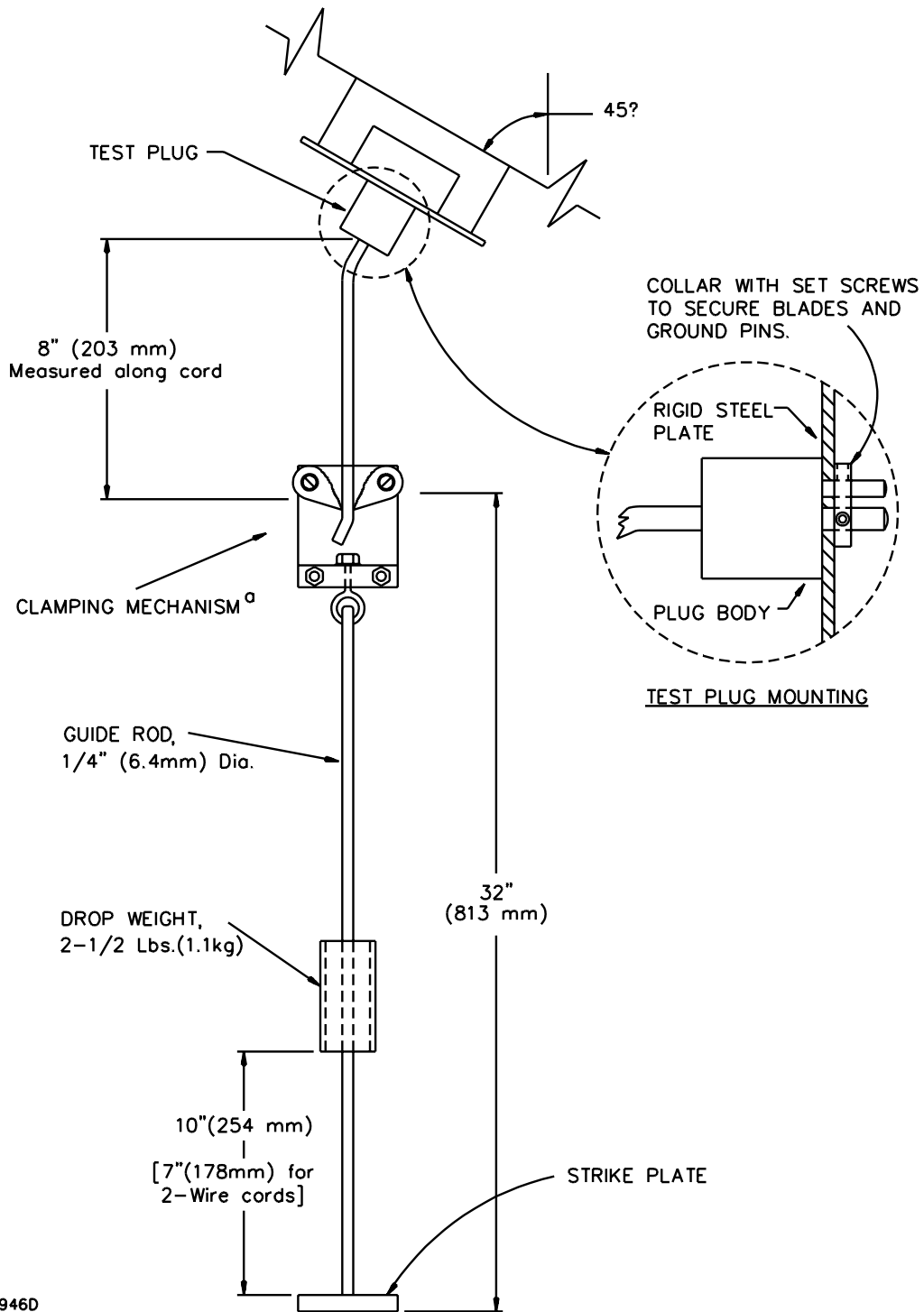

<sup>a</sup> See Figure 99.2 for detail of clamping mechanism.

99.1.4 The strike-plate/weight assembly shall be suspended from the cord, using a clamping mechanism similar to that depicted in Figure 99.2. The distance, measured along the cord, from the center of the gripping area of the clamping mechanism to the point where the flexible cord exits the molded-on fitting shall be approximately 8 inches (203 mm). The distance between the point of the striker-plate assembly's connection to the flexible cord (center of gripping area) to the bottom of the striker plate shall be not more than 32 inches (813 mm). The combined weight of the striker-plate assembly and holding clamp, exclusive of the 2-1/2 lb (1.1 kg) drop weight, shall be 2 lb  $\pm$ 3 oz (907 g  $\pm$ 85 g).

99.1.5 The representative assembly being tested shall be subjected to an impact by raising and releasing a 2-1/2 lb (1.1 kg) weight, allowing it to fall freely for a distance of 10 inches (254 mm) to impact the strike plate. This procedure shall be repeated until:

- a) Discontinuity of the grounding conductor or either line conductor results, or
- b) 25 impacts are completed.

The opening of line and grounding conductors is to be determined using a continuously-monitoring detection circuit.

99.1.6 For each discontinuity obtained through the testing described in 99.1.5, the following is to be recorded:

- a) The number of impacts necessary to produce the discontinuity, and
- b) The circuit (grounding or line) in which it occurred.

99.1.7 In the event that the grounding conductor doesn't break before any of the line conductors or the test is discontinued after the maximum of 25 impacts has been reached, the acceptability of the grounding conductor is to be verified by causing it to carry a current of 40 A at 6 – 12 V for 2 minutes.

## 99.2 Two conductor representative devices

99.2.1 The method for performing the abrupt pull test on fittings molded onto 2-wire cords is essentially that described in 99.1.1 – 99.1.6, except as noted in 99.2.2 and 99.2.3. Two conductor cords are acceptable if they can complete 5 impacts without the opening of any conductors as described in 99.1.1. In applying the test in 99.1.1 – 99.1.6 to 2-conductor devices, any mention of the testing or detection of discontinuity in the grounding conductor is to be disregarded.

*Exception No. 1: The abrupt pull test is not required for power-supply cords employing Types XTW, CXTW, TPT, TS, TST, shaver, and clock cords.*

*Exception No. 2: The abrupt pull test is not required for cord sets and power-supply cords employing No. 10 AWG and larger flexible cords.*

99.2.1 revised March 16, 2001

99.2.2 Instead of the test value indicated in 99.1.5, the 2-1/2 lb (1.1 kg) weight shall be released to fall freely for 7 inches (178 mm) to impact the strike plate.



Figure 99.2  
Clamping mechanism

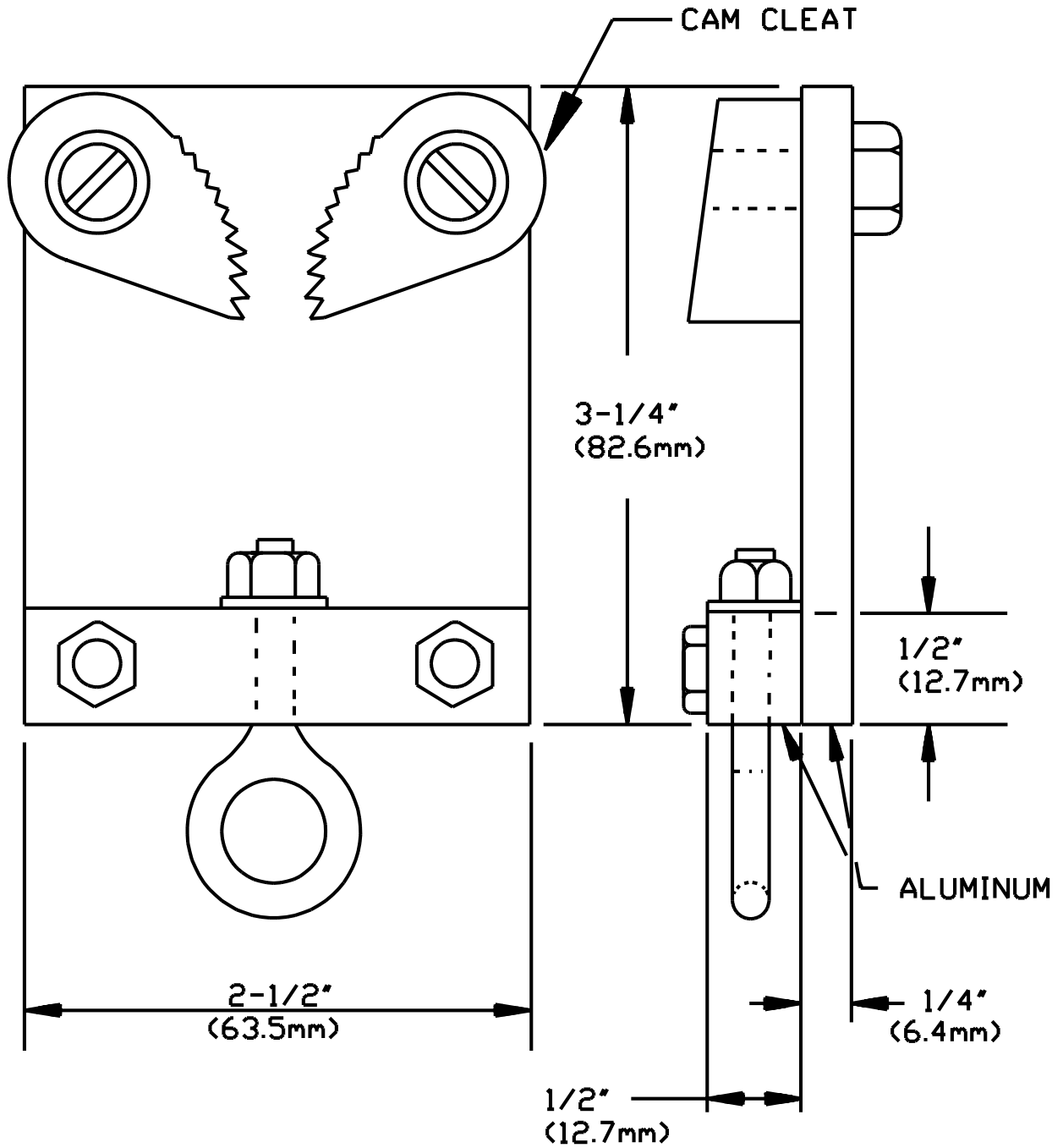

S2947

99.2.3 Instead of the test orientations described in 99.1.2, each of six representative devices required, two is to be tested in each of the following orientations:

- a) Blades in the vertical position,
- b) Fitting rotated 90° to the right of the vertical position, and
- c) Fitting rotated 90° to the left of the vertical position.

See Figure 99.3. Right angle plugs are to be tested only in the cord-down position.

**Figure 99.3**  
**Orientations for abrupt pull test for two conductor representative devices**  
**STARTING POSITION**

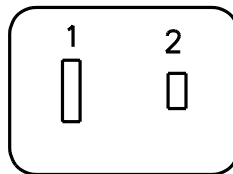

90° TO LEFT

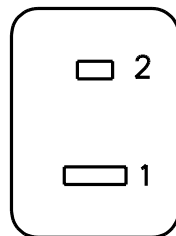

90° TO RIGHT

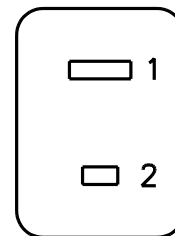

S2948

## 100 Jacket Retention Test

### 100.1 General

100.1.1 Following the tests described in this section, there shall not be any fillers, separators, insulation, or bare conductors visible at the point where the cord enters the fitting. A molded-on attachment plug, cord connector, or current tap of a cord set or power-supply cord, including a nonintegral parallel-type cord, employing No. 18, 16 or 14 AWG conductors shall be so tested to determine the ability of the fitting to acceptably retain the jacket of the flexible cord to which it is molded.

## **100.2 Method I – applicable to molded-on assemblies employing attachment plugs and current taps**

100.2.1 The molded-on fittings of each of six representative assemblies, with 12 inches (305 mm) of flexible cord attached, shall be rigidly secured by the blades to the test apparatus used for the abrupt pull test described in Section 99. The flexible cord of each assembly is to be subjected to 10 impacts using the method described in that section. Immediately, following the 10 impacts, compliance with 100.1.1 shall be determined using the procedure described in 100.2.2 and 100.2.3.

100.2.2 Using any convenient method, each molded-on fitting is then to be connected – by the body – to a test apparatus having a vertical assembly capable of rotating through 360 degrees and securing the fitting so that the cord exits the fitting being tested with the longitudinal axis of the cord in a horizontal direction, perpendicular to the plate face.

100.2.3 A weight of 3 lb (1.4 kg) is to be suspended at a point 8 inches (203 mm) from where the cord enters the fitting for 15 seconds. With the weight still attached, the test apparatus mounting plate then is to be rotated 360° about the horizontal axis of the cord exit (from the fitting) in 15 seconds, during which time the cord-body interface is to be visually examined to determine compliance with 100.1.1.

## **100.3 Method II – applicable to all molded-on fitting assemblies**

100.3.1 Each of six previously untested representative assemblies, with 12 inches (305 mm) of flexible cord attached, shall be used for the test in Method II. The cord jacket of each of the assemblies is to be slit for a short distance at a point 6 inches (152 mm) from the point of cord entry to the fitting. All internal conductors, conductor insulation, fillers, and separators are to be severed.

100.3.2 Representative assemblies shall then be secured by the body of the molded-on fitting so that the flexible cord jacket is hanging vertically, and a 15 lbf (67 N) is to be applied for 2 minutes at a point 8 inches (203 mm) from where the cord enters the fitting.

100.3.3 Compliance with 100.1.1 shall then be determined using the procedure described in 100.2.2 and 100.2.3.

## **101 Overcurrent Protective Devices**

### **101.1 General**

101.1.1 An overcurrent protective device, as mentioned in 21.1 and 29.1 is to be subjected to the calibration, short-circuit, abnormal operation, and water exclusion tests described in this section.

101.1.2 An overcurrent protective device, as mentioned in 48.1 shall be subjected to the short-circuit tests described in 101.3.1 – 101.4.1 and the abnormal operation tests described in 101.5.1 and 101.5.5.

101.1.3 Each representative device for the calibration and short-circuit tests in 101.2.1 and 101.3.1 is to consist of the overcurrent protective device in its enclosure and a length of cord sufficient to permit the necessary electrical connections to be made (approximately 3 inches or 76 mm).

## 101.2 Calibration test

101.2.1 The calibration test consists of testing each of three representative devices at 135, 150, and 200 percent of its current rating. These devices shall open the circuit within 60 minutes while carrying 135 percent, within 10 minutes when carrying 150 percent, and within 2 minutes when carrying 200 percent of its rating. No externally soldered connections shall melt, and the casing or enclosure shall not char or rupture in any manner.

## 101.3 Short-circuit tests for all products with overcurrent protection

101.3.1 The short-circuit test consists of testing each of three representative devices and its enclosure (total of six) on 120-V, 60 Hz circuits capable of delivering 200 A and 1000 A, at a power factor of 70 – 80 percent, with the protective devices in series with a 20 A time-delay fuse. During the test, the protective device enclosure is to be surrounded with absorbent cotton. Results are acceptable if the cotton is not ignited.

101.3.2 Cord sets and power-supply cords incorporating overcurrent protective devices shall be subjected to a second short-circuit test (in addition to the one described in 101.3.1). The representative device is to consist of the line fitting, and for cases involving a through-cord protector, the maximum length of cord used between the line fitting and the protective device, the protector, its enclosure, plus an additional 6 ft (1.8 m) of cord beyond the protective-device enclosure.

101.3.3 Each test representative device is to be prepared by removing approximately 0.5 inch (13 mm) of the insulation from the end of each circuit conductor. The stripped end of one conductor is to be twisted to join it with the conductor of opposite polarity.

101.3.4 Each of three representative devices described in 101.3.2 and 101.3.3, with their protective devices in place, is to be subjected to the 120 V, 200- and 1000 A, 60 Hz short-circuit tests described in 101.3.1. The representative device is to be connected to the power source by means of its attachment plug blades. The protector enclosure is to be surrounded with absorbent cotton. The results are acceptable if:

- a) There is no ignition of the cotton, and
- b) The cord does not flame or melt to the extent that bare conductors are exposed.

#### 101.4 Short-circuit test for fuses

101.4.1 Fuses employed as overcurrent protective devices shall be tested as described in the section titled Interrupting Ability Tests in the Standard for Fuses for Supplementary Overcurrent Protection, UL 198G, to determine that they function up to their marked short-circuit current rating without introducing a risk of fire, electric shock, or injury to persons.

#### 101.5 Abnormal test

101.5.1 Three complete cord sets or power-supply cords shall be subjected to each of the abnormal tests described in 101.5.2 – 101.5.4. For each test, the protector is to be surrounded with absorbent cotton. The results are acceptable if:

- a) There is no ignition of the cotton; and
- b) The cord and fuseholder do not flame or melt to the extent that bare conductors are exposed.

*Exception: Three complete power-supply cords having No. 20 AWG (0.52 mm<sup>2</sup>) conductors, and employing either Appliance Wiring Material constructed in accordance with note m to Table 44.1, or Type SP-1, NISP-1, SPE-1, NISPE-1, SPT-1, or NISPT-1 flexible cord, shall instead be subjected to the abnormal test described in 101.5.5.*

101.5.1 revised March 16, 2001

101.5.2 Overcurrent protective devices shall be subjected to 110 percent of their marked rating for 7 hours.

101.5.3 For products that employ replaceable fuses, the supplied fuse is to be replaced with a dummy fuse (short circuited) and the product subjected to 135 percent of its marked rating for 60 minutes.

101.5.4 Products employing replaceable fuses shall be tested as described in 101.5.3 but with 150 percent of the marked rating applied for 10 minutes.

101.5.5 To determine compliance with the Exception to 101.5.1, three complete power-supply cords having No. 20 AWG (0.52 mm<sup>2</sup>) conductors and employing either Appliance Wiring Material constructed in accordance with note m to Table 44.1, or Type SP-1, NISP-1, SPE-1, NISPE-1, SPT-1, or NISPT-1 flexible cord, are to be tested as follows:

- a) Each overcurrent protective device is to be subjected to 110 percent of its marked ampere rating for 7 hours.
- b) If the power-supply cord is provided with a replaceable overcurrent protective device, each cord is to be additionally tested with the overcurrent protective device short-circuited and the test current increased to 135 percent for 60 minutes, and then 200 percent for 2 minutes.

101.5.5 revised March 16, 2001

## **101.6 Water exclusion test for enclosures of outdoor-use products**

101.6.1 The enclosure of an overcurrent protective device intended for use on an outdoor-use cord set or power-supply cord and the enclosure of a switch intended for use on an outdoor-use cord set shall be tested to determine that water does not contact live parts when tested using the water-spray apparatus shown in Figure SA10.2.

101.6.2 Through-cord fuseholders and cord connectors serving as overcurrent protective device enclosures and switch enclosures are to be subjected to the water-spray test while placed flat on a board and positioned so that the focal point of the water spray is that most likely to result in the entrance of water. Any receptacle openings shall be sealed against the entrance of water prior to the test.

101.6.3 Attachment plugs and current taps serving as overcurrent-protective-device enclosures are to be tested while mounted in a receptacle, which is likewise mounted in a vertical position, so that the attachment plug or current tap is located at the focal point of the water spray in the position and orientation most likely to result in the entrance of water.

101.6.4 The test shall be continued for one hour.

## **102 Test for Permanence of Cord Tag**

### **102.1 General**

102.1.1 To determine compliance with 23.14 and 35.7, representative tags that have been subjected to the tests described in 102.2.1 – 102.3.1 shall meet the following requirements:

- a) The tag shall resist tearing for longer than 1/16 inch (1.6 mm) at any point;
- b) The tag shall not separate from the cord set. A hang-type tag shall not separate from the securement strap, and the securement strap shall not separate from the cord set;
- c) The tag or securement strap shall not slip or move along the length of the cord set more than 1/2 inch (13 mm) and there shall not be any visible damage to the cord;
- d) There shall not be any permanent shrinkage, deformation, cracking, or any other condition that will render the marking on the tag illegible; and
- e) Overlamination, if provided, shall remain in place and shall not be torn or otherwise damaged. The printing shall remain legible.

## 102.2 Test conditions

102.2.1 For each type of conditioning mentioned in 102.2.2 – 102.2.4, three tags applied to the cord sets in the intended manner are to be used. If tags are applied by an adhesive, tests are to be conducted no sooner than 24 hours after application of the tag.

102.2.2 Each of three tags is to be tested as received.

102.2.3 Each of three tags is to be tested after 30 minutes of conditioning at  $23.0 \pm 2.0^{\circ}\text{C}$  ( $73.4 \pm 3.6^{\circ}\text{F}$ ) and  $50 \pm 5$  percent relative humidity, following 240 hours of conditioning in an air-circulating oven at  $60 \pm 1^{\circ}\text{C}$  ( $140 \pm 1.8^{\circ}\text{F}$ ).

102.2.4 Each of three tags is to be tested within 1 minute after being exposed for 72 hours to a relative humidity of  $85 \pm 5$  percent at a temperature of  $32.0 \pm 2.0^{\circ}\text{C}$  ( $89.6 \pm 3.6^{\circ}\text{F}$ ).

102.2.5 If the tag is intended to be applied to outdoor cord (W) it is to be conditioned as follows and in 102.2.6 – 102.2.8. Each of three tags is to be tested after 24 hours of exposure conditioning at  $23 \pm 2^{\circ}\text{C}$  ( $73.4 \pm 3.6^{\circ}\text{F}$ ) and  $50 \pm 5$  percent relative humidity, followed by 48 hours of immersion to a depth of not less than 1/8 inch (3.2 mm) in demineralized water at a temperature of  $23^{\circ}\text{C}$  ( $73.4^{\circ}\text{F}$ ).

102.2.6 Each of three tags is to be tested after 24 hours of exposure conditioning at  $23.0 \pm 2.0^{\circ}\text{C}$  ( $73.4 \pm 3.6^{\circ}\text{F}$ ) and  $50 \pm 5$  percent relative humidity, followed by 10 days of exposure in an air-circulating oven at a temperature of  $60^{\circ}\text{C}$  ( $140^{\circ}\text{F}$ ).

102.2.7 Each of three tags is to be tested after 24 hours of exposure conditioning at  $23.0 \pm 2.0^{\circ}\text{C}$  ( $73.4 \pm 3.6^{\circ}\text{F}$ ) and  $50 \pm 5$  percent relative humidity, followed by 7 hours of exposure in a cold box at a temperature of  $-10 \pm 2^{\circ}\text{C}$  ( $14.0 \pm 3.6^{\circ}\text{F}$ ).

102.2.8 Each of three tags is to be tested after 24 hours of exposure conditioning at  $23.0 \pm 2.0^{\circ}\text{C}$  ( $73.4 \pm 3.6^{\circ}\text{F}$ ) and  $50 \pm 5$  percent relative humidity, followed by exposure to ultraviolet light and water spray with ultraviolet light by using either of the following apparatus:

a) A Twin-Enclosed Carbon-Arc Weatherometer, (Type D or DH), as described in the Standard Practice for Operating Open Flame Carbon Arc Light Apparatus for Exposure of Nonmetallic Materials, ASTM G 152 and ASTM G 153. Each of the tags is to be exposed to 720 hours of ultraviolet light and water spray with ultraviolet light. The operating cycle is to be 20 minutes; 17 minutes of ultraviolet light only and 3 minutes of water spray and ultraviolet light.

b) A Xenon-Arc Weatherometer, (Type B or similar apparatus), as described in the Standard Practice for Operating Xenon Arc Light Apparatus for Exposure of Non-Metallic Materials, ASTM G 155. Each of the tags is to be exposed to 1000 hours of ultraviolet light and water spray with ultraviolet light. The exposure shall be in accordance with Method A, with continuous exposure to ultraviolet light and intermittent water spray with ultraviolet light, using a programmed cycle of 120 minutes (102 minute ultraviolet light exposures and an 18 minute exposure to water spray with ultraviolet light). The apparatus shall include a 6500 W, water-cooled xenon-arc lamp, borosilicate glass inner and outer optical filters, a spectral irradiance of  $0.35 \text{ W/m}^2$  at 340 nm and a black-panel temperature of  $63.0 \pm 3.0^{\circ}\text{C}$  ( $145.0 \pm 5.4^{\circ}\text{F}$ ).

102.2.9 If the tag is intended to be applied to indoor or outdoor cord that is oil resistant (Type O or OO) it is to be conditioned as follows. Each of three tags is to be tested within two minutes after being immersed for 48 hours in Fuel Oil No. 1 at a temperature of  $23.0 \pm 2.0^{\circ}\text{C}$  ( $73.4 \pm 3.6^{\circ}\text{F}$ ).

### 102.3 Test method

102.3.1 Each test is to be performed on a length of cord set to which the tag has been applied. The cord set, with the attachment plug pointing up, is to be held taught in a vertical plane. A force of 5 pounds (22.2 N), which includes the weight of the clamp, is to be applied for 1 minute to the uppermost corner of the tag farthest from the cord set, within 1/4 inch (6.4 mm) of the vertical edge of the tag. The force is to be applied by affixing a C-clamp with a pad diameter of 3/8 inch (9.5 mm) to the tag and securing the weight to the C-clamp. The force is to be applied vertically downward in a direction parallel to the major axis of the cord. To determine compliance with 102.1.1(d), manipulation is permissible, such as straightening of the tag by hand. To determine compliance with 102.1.1(e), each tag is to be scraped 10 times vertically across printed areas and edges, with a force of approximately 2 pounds (9 N), using the edge of a 5/64 inch (2.0 mm) thick steel blade held at a right angle to the test surface. The edges of the steel blade are to be just rounded so as not to be sharp.

### 103 Cord Connector Closure Test

Section 103 effective June 1, 2002

103.1 After being tested as described in this Section, the closure of a cord connector, when removed from the outlet, shall not slip or move along the length of the cord more than 1/2 inch (13 mm) and there shall not be any visible damage to the cord or closure.

103.2 Each of three representative cord sets employing removable closures is to be tested as received and three of the same are to be tested after being conditioned as described in 26.7.3(c). Each cord set is to be held in a vertical plane with the cord connector pointing up and the closure removed from the outlet. A force of 5 pounds (22.2 N) which includes the weight of the clamp, is to be applied for 1 minute to the center of the closure. The force is to be applied by affixing a C-clamp with a pad diameter of 3/8 inch (9.5 mm) to the closure and securing the weight to the C-clamp. The force is to be applied vertically downward in a direction parallel to the major axis of the cord.

## MANUFACTURING AND PRODUCTION TESTS

### 104 Dielectric Voltage-Withstand Test

104.1 Each cord set and power-supply cord shall be capable of withstanding without electrical breakdown, as a routine production line test, the application of a test potential between line conductors and between each line conductor and grounding conductor, if provided, using one of the following methods.

- a) A 1250 V a-c (40 – 70 Hz) test potential applied for 1 minute,
- b) A 1500 V a-c (40 – 70 Hz) test potential applied for 1 second,
- c) A 1770 V d-c test potential applied for 1 minute, or
- d) A 2100 V d-c test potential applied for 1 second.



104.2 The test potential may be gradually increased to the required value but the full value is to be applied for 1 second or 1 minute as required.

104.3 The test equipment for a-c testing shall include a transformer having an essentially sinusoidal output.

104.4 If the output of the test equipment power-supply is less than 500 VA, the equipment shall include a voltmeter in the output circuit to directly indicate the test potential, and an audible or visual indication of breakdown. In the event of breakdown, manual reset of an external switch is required or an automatic reject of the unit under test is to result.

104.5 If the output of the test equipment power-supply is 500 VA or larger, the test potential may be indicated by a voltmeter in the primary circuit or in a tertiary winding circuit, by a selector switch marked to indicate the test potential, or by a marking in a readily visible location to indicate the test potential of equipment having a single test potential output. When marking is used without an indicating voltmeter, the equipment shall include a positive means such as a power-on lamp to indicate that the manual reset switch has been reset following a tripout. In the event of breakdown, manual reset of an external switch is required or an automatic reject of the unit under test is to result.

104.6 Test equipment other than that described in 104.3 – 104.5 may be used if found to accomplish the intended factory control.

## **105 Polarization and Continuity Test**

105.1 All 3-wire grounding cord sets and power-supply cords shall be tested to verify that in each product

- a) The conductors are connected to the intended terminals of the fittings and
- b) There is electrical continuity throughout the entire length of the conductor/contact assembly.

*Exception: If it can be determined that the product can be assembled only in a manner that provides correct connections, polarity, and electrical continuity, the tests do not have to be applied.*

105.2 All cord sets and power-supply cords that employ a grounding conductor or that employ fittings having designated contacts shall be tested to verify that in each product

- a) Each of the conductors is connected to the intended terminals of the fittings and
- b) There is electrical continuity throughout the entire length of the conductor/contact assembly.

*Exception: If it can be determined that the product can be assembled only in a manner that provides correct connections, polarity, and electrical continuity, the tests do not have to be applied.*

## HOSPITAL GRADE ATTACHMENT PLUG PROGRAM

### 106 General

106.1 A Hospital Grade attachment plug shall comply with the requirements in Sections 107– 114 and with all other applicable requirements in this standard.

## CONSTRUCTION

### 107 General

107.1 The strain relief system shall not permit any forces applied to the cord to be transmitted to the point of electrical termination of the cord conductors inside the fitting. This shall be determined by the tests in Strain Relief Test, Section 109.

107.2 The blades shall be formed of solid brass material in conformance with Standard for Wiring Devices – Dimensional Requirements, ANSI/NEMA WD 6. The grounding pin shall not be capable of being easily bent or removed without the use of tools.

107.2 revised June 24, 2003

107.3 The size of an attachment plug shall provide for the full insertion of two attachment plugs simultaneously into a duplex receptacle.

107.4 The flexible cord employed shall be Type SJO, SJT, SJTO, SVO, SVT, SVTO, or other jacketed type cord at least as serviceable.

## PERFORMANCE

### 108 General

108.1 In addition to the representative devices required for the general testing specified elsewhere in this standard, the following representative devices are necessary: A minimum of 40 molded-on assemblies, of which 20 shall be complete and 20 shall be complete but without internal electrical connection of the conductors to the blades and grounding pin, and 10 unmolded representative devices that are complete but without the molded-on body (note: for these representative devices, clear identification of conductor size is required). Previously untested representative devices shall be used for each test.

## 109 Strain Relief Tests

### 109.1 General

109.1.1 After being subjected to the strain relief tests described in this section, there shall not be any displacement of the conductors, conductor insulation, or outer jacket of the flexible cord exceeding 1/32 inch (0.8 mm). There shall not be any cuts, rips, or tears in the cord insulation nor any breakage of the attachment plug that could adversely affect the enclosure of live parts, strain relief, or grounding path integrity.

### 109.2 Method A – Static pull

109.2.1 Each of six representative attachment plugs molded onto flexible cord, without the conductors terminated to the blades or grounding pin, shall be subjected to a gradually applied pull of 30 lbf (133 N) to the free end of the cord while the attachment plug is securely supported. The force shall be applied for 1 minute in a direction perpendicular to the plane of cord entry.

### 109.3 Method B – Rotary pull

109.3.1 Each of six representative attachment plugs molded onto flexible cord, without the conductors terminated to the blades or grounding pin, shall be subjected to a rotary cord motion while a force of 10 lbf (44.5 N) is applied for 2 hours. The cord is to be rotated at a rate of approximately 9 r/min in a 3 inch diameter (76 mm) circle at a point 6 inches (152 mm) below the cord exit with the attachment plug rigidly mounted. (Note – This test is conveniently done with UL secureness test apparatus described in the Standard for Wire Connectors and Soldering Lugs for Use With Copper Conductors, UL 486A, or in the Standard for Wire Connectors for Use With Aluminum Conductors, UL 486B.)

### 109.4 Method C – Abrupt removal

109.4.1 Each of six representative attachment plugs molded onto flexible cord, without the conductors terminated to the line blades or grounding pin, shall be subjected to one abrupt removal from a Hospital Grade receptacle in accordance with the procedure described in 109.4.3. Each of three attachment plugs shall be removed with the test receptacle horizontal and three with the receptacle vertical, grounding contact up. One half of the attachment plugs are to be tested using a receptacle that has the grounding contact integral with the strap. The remaining attachment plugs are to be tested with a receptacle having separate grounding contacts riveted to the strap. A new plug is to be used for each abrupt removal.

109.4.2 The Hospital Grade receptacle is first to be mounted to represent a typical installation and a 0.030 plus 0.003 minus 0.0 inch (0.76 plus 0.08 minus 0.0 mm) thick steel faceplate rigidly mounted as intended, being supported around its perimeter. The receptacle face is to be in a vertical plane in a manner that will facilitate the necessary test orientations.

109.4.3 Each abrupt removal shall consist of the full insertion of the attachment plug followed by the complete withdrawal by means of a 10 lb (4.5 kg) weight dropped from a height of 24 inches (610 mm) (measured from the bottom of the weight) onto a striker plate attached to the plug by a 1/4 inch (6.4 mm) diameter guide rod using the method described in 109.4.4. The guide rod shall be located vertically below the outlet being tested, and 2 inches (50.8 mm) in front of the plane of the receptacle face (see Figure 109.1). The applied force shall cause the removal of the test plug in one continuous motion.

109.4.4 The means to connect the attachment plug to be tested to the 1/4 inch (6.4 mm) diameter guide rod shall be as follows. The representative attachment plug shall include a 12 inch (305 mm) length of flexible cord. A figure-eight knot is to be tied in the flexible cord such that when an S-hook is inserted into the lower loop of the knot its top is located 8 inches (203 mm) from the point of cord entry to the plug, measured along the cord. To facilitate hanging the guide rod from the S-hook, the top of the rod is to be formed into a loop. See Figure 109.1.

## 110 Crushing Test

110.1 A Hospital Grade attachment plug shall be capable of withstanding the crushing test without resulting in breakage, deformation, or other adverse effects that may interfere with the intended function of the device.

110.2 Each of six representative attachment plugs molded onto flexible cord is to be placed between rigid horizontal steel plates. A crushing force is to be applied, then gradually increased to a value of 500 lbf (2224 N). The force is then to be gradually removed. Each attachment plug is to be oriented in a natural resting position before applying the force. In no case is the force to be applied to the projecting blades.

## 111 Impact Resistance Test

111.1 As a result of the impact resistance test there shall be no breaking of the body or other damage that may adversely affect the function of an attachment plug.

111.2 Each of six representative attachment plugs molded onto flexible cord is to be subjected to an impact caused by dropping a cylindrical 10 lb (4.5 kg) weight, having a flat face that is 2 inches (50.8 mm) in diameter, from a height of 18 inches (457 mm). Each attachment plug is to be placed on a hardwood surface in any natural resting position. A cylindrical attachment plug is to have its major axis parallel to the surface. The hardwood surface shall be a maple block approximately 1-5/8 inches (41.3 mm) thick by 4-1/2 inches (114 mm) square and is to rest on a fixed surface such as a concrete floor.

## 112 Mechanical Drop Test

112.1 Following the mechanical drop test:

- a) There shall not be any chipping, breaking, or loosening of parts that could adversely affect the functioning of the device, and
- b) The attachment plug shall be capable of withstanding the dielectric voltage-withstand test in 109.4.2.

112.2 This test is not required of attachment plugs of an elastomeric material such as plasticized vinyl or rubber.

112.3 Each of six representative attachment plugs molded onto flexible cord of a length sufficient for mounting on the test apparatus shown in Figure 112.1 is required. A 0.250 inch diameter (6.35 mm) braided nylon rope or its equivalent may be used to facilitate handling by the apparatus. The cord and attachment plug assembly shall be supported at point A so that, when hanging freely, the attachment plug rests against the vertical maple block 45 inches (1143 mm) below point A. A moving member of the test apparatus is to lift the test assembly to the test position B shown in Figure 112.1 and then release it causing the plug to fall freely and strike the impact block at point C.

Figure 109.1  
Test set-up for abrupt removals test

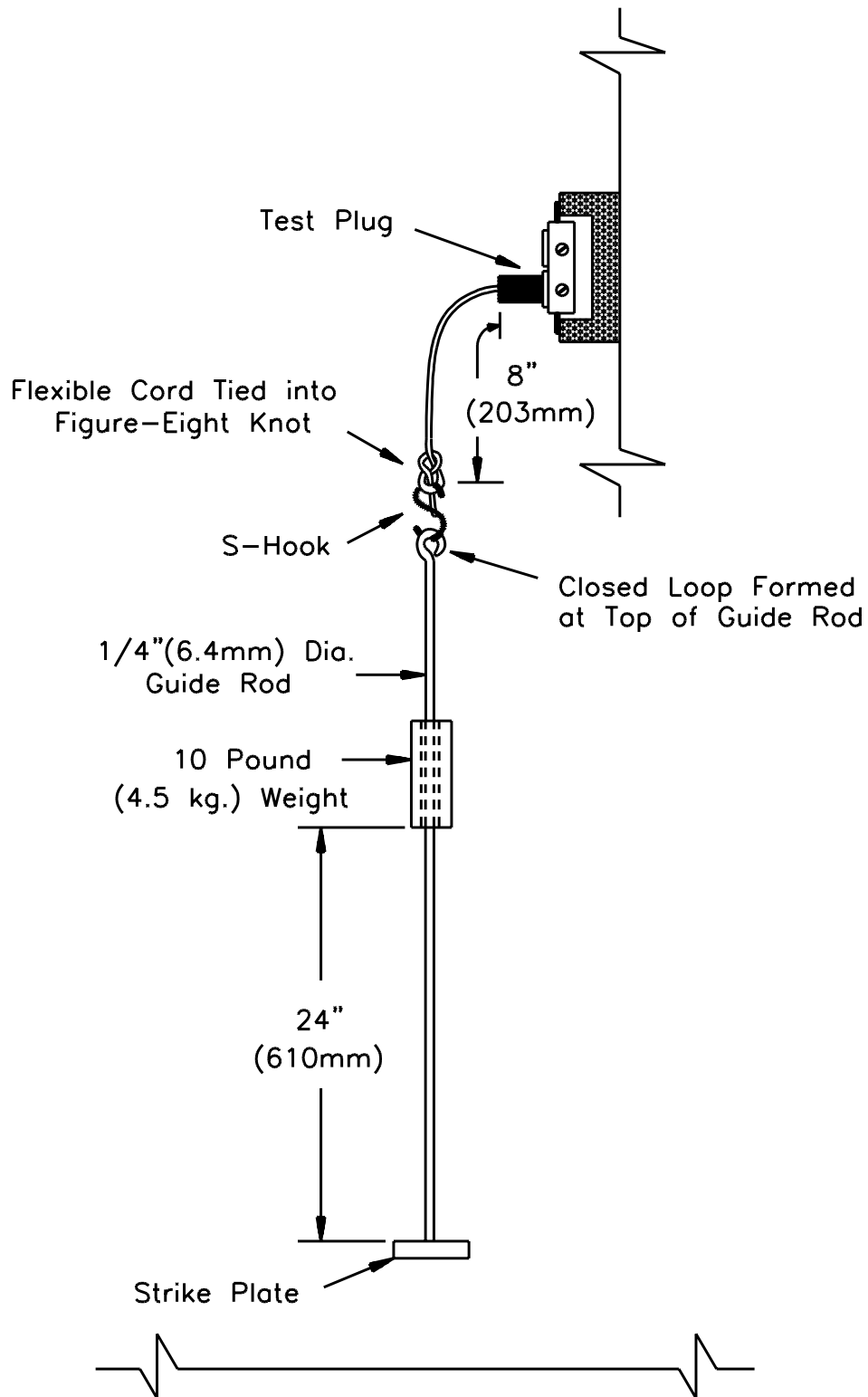

S2894A

**Figure 112.1**  
**Mechanical drop test apparatus**

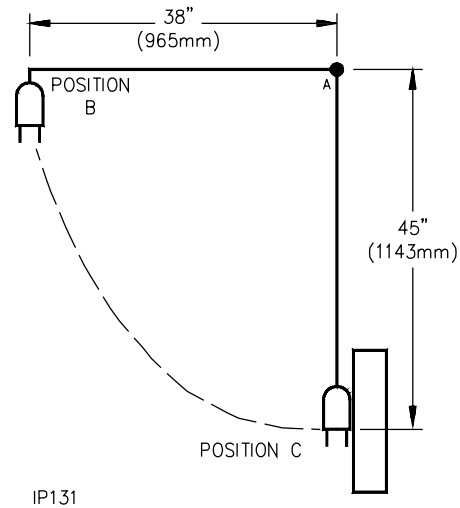

Note: A hard maple impact board is to be mounted rigidly with the grain of the wood running vertically. The board shall be 1-1/2 – 2 inches (38 – 51 mm) thick, of an appropriate width and length, and so located that when the device is released, it will not strike near any edge of the board.

112.4 Each representative attachment plug is to be tested for not more than 1300 cycles. Each attachment plug is to complete not less than 500 cycles, and the average of the number of cycles completed by all attachment plugs is to be not less than 1000 cycles. Attachment plugs shall be inspected every 50 cycles beginning with the completion of 450 cycles.

112.5 The mechanical drop testing in 112.3 and 112.4 is to be followed by a dielectric voltage-withstand test of two times the plug voltage rating plus 1000 V applied between live parts of opposite polarity and between live parts and grounded metal parts for a period of 1 minute.

## MARKING

### 113 General

113.1 Attachment plugs designated Hospital Grade shall additionally be marked in accordance with the requirements in this section.

113.2 An attachment plug shall be marked with the phrase "Hospital Grade" and with a green dot. One or both markings may appear on the face of the fitting. The phrase "Hospital Grade" is also acceptable on other external surfaces of the plug. The green dot shall be as described in 113.3 and 113.4.

113.3 The green dot shall be a contrasting shade of green if on a green-bodied device and shall be 3/16 inch (4.8 mm) minimum, 1/4 inch (6.4 mm) maximum in diameter.

113.4 The green dot shall be ink stamped, painted, or otherwise applied in a manner determined to be indelible. A label or sticker marked with the green dot shall be accompanied by the phrase "Hospital Grade" and shall be attached by an adhesive or other means to the device so that it is not readily removable without destroying its significance if reapplied.

## TABLES

### 114 Cord Ampacity and Voltage Ratings

**Table 114.1**  
**Circuit-conductor ampacity and voltage rating for braid-covered cords in general-use cord sets and power-supply cords**

Types of cord	Size of conductors in cord	Number of cord conductors	Number of current-carrying conductors <sup>a</sup>	Ampacity of current-carrying conductors – (amperes)		Voltage rating of cord
				0 – 50 Ft (0 – 15.2 m)	Over 50 Ft (Over 15.2 m)	
C or PD	18	2, 3 or 4	2	10	7	300
		3 or 4	3	7	5.6	300
	16	2, 3 or 4	2	13	10	300
		3 or 4	3	10	7	300
	14	2, 3 or 4	2	18	13	600
		3 or 4	3	15	10	600
	12	2, 3 or 4	2	25	15	600
		3, 4 or 5	3	20	15	600
	10	2, 3 or 4	2	30	25	600
		3, 4 or 5	3	25	20	600

<sup>a</sup> A conductor that is used to carry an unbalanced current from the other conductors is not considered to be a current-carrying conductor.

**Table 114.2**  
**Circuit-conductor ampacity and voltage rating for jacketed cords in general-use cord sets and power-supply cords**

Table 114.2 revised March 16, 2001

Types of cord	Size of conductors in cord	Number of cord conductors	Number of current-carrying conductors <sup>a</sup>	Ampacity of current-carrying conductors – (amperes)		Voltage rating of cord
				0 – 50 Ft (0 – 15.2 m)	Over 50 Ft (Over 15.2 m)	
S, SO, SOO, ST, STO, STOO, SE, SEO, or SEOO	18	2, 3 or 4	2	10	7	600
		3 or 4	3	7	5.6	600
	16	2, 3 or 4	2	13	10	600
		3 or 4	3	10	7	600
	14	2, 3 or 4	2	18	13	600
		3 or 4	3	15	10	600
	12	2, 3 or 4	2	25	18	600
		3, 4 or 5	3	20	15	600
	10	2, 3 or 4	2	30	25	600
		3, 4 or 5	3	25	20	600
	8	2, 3 or 4	2	40	30	600
		3, 4 or 5	3	35	25	600
	6	2, 3 or 4	2	55	40	600
		3, 4 or 5	3	45	35	600
	4	2, 3 or 4	2	70	55	600
		3 or 4	3	60	45	600
2	2, 3 or 4	2	95	70	600	
	3, 4 or 5	3	80	60	600	
SJ, SJO, SJOO, SJT, SJTO, SJTOO, SJE, SJEO, or SJEOO	18	2, 3 or 4	2	10	7	300
		3 or 4	3	7	5.6	300
	16	2, 3 or 4	2	13	10	300
		3 or 4	3	10	7	300
	14	2, 3 or 4	2	18	13	300
		3 or 4	3	15	10	300
	12	2, 3 or 4	2	25	18	300
		3 or 4	3	20	15	300
	10	2, 3 or 4	2	30	25	300
		3 or 4	3	25	20	300
SV, SVO, SVOO, SVT, SVTO, SVTOO, SVE, SVEO, or SVEOO	18	2 or 3	2	10	7	300
	17	2 or 3	2	12	10	300

<sup>a</sup> A conductor that is used to carry an unbalanced current from the other conductors is not considered to be a current-carrying conductor.



**Table 114.3**  
**Circuit-conductor ampacity and voltage rating for braidless parallel cord in general-use cord sets and power-supply cords**

Table 114.3 revised March 16, 2001

Types of cord	Size of conductors in cord	Number of cord conductors	Number of current-carrying conductors <sup>a</sup>	Ampacity of current-carrying conductors – (amperes)		Voltage rating of cord
				0 – 50 Ft (0 – 15.2 m)	Over 50 Ft (Over 15.2 m)	
Appliance Wiring Material <sup>d</sup>	20 <sup>b</sup>	2	2	2 <sup>e</sup>	–	300
HPN	18	2 or 3	2	10	7	300
	17	2 or 3	2	12	10	300
	16	2 or 3	2	15	12	300
	14	2 or 3	2	20	17	300
	12	2 or 3	2	30	20	300
SP-1 <sup>b</sup> SPT-1 <sup>b</sup> SPE-1 <sup>b</sup> NISP-1 NISPT-1 or NISPE-1	20	2	2	2 <sup>e</sup>	–	300
	18	2 or 3	2	10	7	300
SP-2 <sup>c</sup> SPT-2 <sup>c</sup> SPE-2 <sup>c</sup> NISP-2 NISPT-2 or NISPE-2	18	2 or 3	2	10	7	300
	16	2 or 3	2	13	10	300
SP-3 <sup>c</sup>	18	2 or 3	2	10	7	300
	16	2 or 3	2	13	10	300
	14	2 or 3	2	18	13	300
	12	2 or 3	2	25	18	300
SPT-3 <sup>c</sup> or SPE-3 <sup>c</sup>	18	2 or 3	2	10	7	300
	16	2 or 3	2	13	10	300
	14	2 or 3	2	18	13	300
	12	2 or 3	2	25	18	300
	10	2 or 3	2	30	25	300

<sup>a</sup> A conductor intended for equipment grounding is not considered to be a current-carrying conductor.

<sup>b</sup> Applicable to power-supply cords only.

<sup>c</sup> Each of these 3-conductor parallel cord types is not acceptable for use on cord sets more than 10 ft (3.0 m) in length.

<sup>d</sup> Constructed in accordance with note m of Table 44.1.

<sup>e</sup> Limited to a maximum length of 12 feet (3.6 m).

## 115 Cord-Set Ratings

**Table 115.1**  
**Ratings of cord sets 125-V, 2-pole, 2-wire, and 2-pole, 3-wire grounding**

Table 115.1 revised March 16, 2001

Description of cord set				
Ratings of fittings used	Length of cord set	Flexible cord used <sup>a</sup>	Ratings of cord set	
15 A at 125 V	over 50 ft (15.2m)	2 or 3-conductor 18 AWG  SJOW, SJOOW, SJTW, SJTOW, SJTOOW, SJEW, SJEOW, SJEOOW, SOW, SOOW, STW, STOW, STOOW, SEW, SEOW, SEOOW	7 A (875 W) maximum at 125 V maximum	
	0 – 50 ft (0 – 15.2m)	2 or 3-conductor 18 AWG  SJOW, SJOOW, SJTW, SJTOW, SJTOOW, SJEW, SJEOW, SJEOOW, SOW, SOOW, STW, STOW, STOOW, SEW, SEOW, SEOOW	10 A (1250 W) maximum at 125 V maximum	
	over 50 ft (15.2 m)	2 or 3-conductor 16 AWG  SJOW, SJOOW, SJTW, SJTOW, SJTOOW, SJEW, SJEOW, SJEOOW, SOW, SOOW, STW, STOW, STOOW, SEW, SEOW, SEOOW		
	0 – 50 ft (0 – 15.2 m)	2 or 3-conductor 16 AWG  SJOW, SJOOW, SJTW, SJTOW, SJTOOW, SJEW, SJEOW, SJEOOW, SOW, SOOW, STW, STOW, STOOW, SEW, SEOW, SEOOW	13 A (1625 W) maximum at 125 V maximum	
	over 50 ft (15.2 m)	2 or 3-conductor 14 AWG  SJOW, SJOOW, SJTW, SJTOW, SJTOOW, SJEW, SJEOW, SJEOOW, SOW, SOOW, STW, STOW, STOOW, SEW, SEOW, SEOOW		
	0 – 50 ft (0 – 15.2 m)	2 or 3-conductor 14–2 AWG  SJOW, SJOOW, SJTW, SJTOW, SJTOOW, SJEW, SJEOW, SJEOOW, SOW, SOOW, STW, STOW, STOOW, SEW, SEOW, SEOOW	15 A (1875 W) maximum at 125 V maximum	
	over 50 ft (15.2 m)	2 or 3-conductor 12–2 AWG  SJOW, SJOOW, SJTW, SJTOW, SJTOOW, SJEW, SJEOW, SJEOOW, SOW, SOOW, STW, STOW, STOOW, SEW, SEOW, SEOOW		
	20 A at 125 V	0 – 50 ft (0 – 15.2 m)	3-conductor 12–2 AWG  SJOW, SJOOW, SJTW, SJTOW, SJTOOW, SJEW, SJEOW, SJEOOW, SOW, SOOW, STW, STOW, STOOW, SEW, SEOW, SEOOW	20 A (2500 W) maximum at 125 V maximum
		over 50 ft (15.2 m)	3-conductor 10–2 AWG  SJOW, SJOOW, SJTW, SJTOW, SJTOOW, SJEW, SJEOW, SJEOOW, SOW, SOOW, STW, STOW, STOOW, SEW, SEOW, SEOOW	

Table 115.1 Continued on Next Page

Table 115.1 Continued

Description of cord set			
Ratings of fittings used	Length of cord set	Flexible cord used <sup>a</sup>	Ratings of cord set
30 A at 125 V	0 – 50 ft (0 – 15.2 m)	3-conductor 10–2 AWG  SJOW, SJOOW, SJTW, SJTOW, SJTOOW, SJEW, SJEOW, SJEOWW, SOW, SOOW, STW, STOW, STOOW, SEW, SEOW, SEOWW	30 A (3750 W) maximum at 125 V maximum
	over 50 ft (15.2 m)	3-conductor 8–2 AWG  SOW, SOOW, STW, STOW, STOOW, SEW, SEOW, SEOWW	
50 A at 125 V	0 – 50 ft (0 – 15.2 m)	3-conductor 6–2 AWG  SOW, SOOW, STW, STOW, STOOW, SEW, SEOW, SEOWW	50 A (6250 W) maximum at 125 V maximum
	over 50 ft (15.2 m)	3-conductor 4 AWG  SOW, SOOW, STW, STOW, STOOW, SEW, SEOW, SEOWW	

<sup>a</sup> Each of the conductors is of the same size. Two-current carrying conductors, the third (when provided) conductor is the grounding conductor.

**Table 115.2**  
**Ratings of cord sets 250-V, 2-pole, 3-wire grounding**

Table 115.2 revised March 16, 2001

Description of cord set			
Ratings of fittings used	Length of cord set	Flexible cord used <sup>a</sup>	Ratings of cord set
15 A at 250 V	over 50 ft (15.2m)	3-conductor 18 AWG  SJOW, SJOOW, SJTW, SJTOW, SJTOOW, SJEW, SJEOW, SJEOW, SOW, SOOW, STW, STOW, STOOW, SEW, SEOW, SEOOW	7 A (1750 W) maximum at 250 V maximum
	0 – 50 ft (0 – 15.2m)	3-conductor 18 AWG  SJOW, SJOOW, SJTW, SJTOW, SJTOOW, SJEW, SJEOW, SJEOW, SOW, SOOW, STW, STOW, STOOW, SEW, SEOW, SEOOW	10 A (2500 W) maximum at 250 V maximum
	over 50 ft (15.2 m)	3-conductor 16 AWG  SJOW, SJOOW, SJTW, SJTOW, SJTOOW, SJEW, SJEOW, SJEOW, SOW, SOOW, STW, STOW, STOOW, SEW, SEOW, SEOOW	
	0 – 50 ft (0 – 15.2 m)	3-conductor 16 AWG  SJOW, SJOOW, SJTW, SJTOW, SJTOOW, SJEW, SJEOW, SJEOW, SOW, SOOW, STW, STOW, STOOW, SEW, SEOW, SEOOW	13 A (3250 W) maximum at 250 V maximum
	over 50 ft (15.2 m)	3-conductor 14 AWG  SJOW, SJOOW, SJTW, SJTOW, SJTOOW, SJEW, SJEOW, SJEOW, SOW, SOOW, STW, STOW, STOOW, SEW, SEOW, SEOOW	
	0 – 50 ft (0 – 15.2 m)	3-conductor 14–2 AWG  SJOW, SJOOW, SJTW, SJTOW, SJTOOW, SJEW, SJEOW, SJEOW, SOW, SOOW, STW, STOW, STOOW, SEW, SEOW, SEOOW	15 A (3750 W) maximum at 250 V maximum
	over 50 ft (15.2 m)	3-conductor 12–2 AWG  SJOW, SJOOW, SJTW, SJTOW, SJTOOW, SJEW, SJEOW, SJEOW, SOW, SOOW, STW, STOW, STOOW, SEW, SEOW, SEOOW	
	20 A at 250 V	0 – 50 ft (0 – 15.2 m)	3-conductor 12–2 AWG  SJOW, SJOOW, SJTW, SJTOW, SJTOOW, SJEW, SJEOW, SJEOW, SOW, SOOW, STW, STOW, STOOW, SEW, SEOW, SEOOW
over 50 ft (15.2 m)		3-conductor 10–2 AWG  SJOW, SJOOW, SJTW, SJTOW, SJTOOW, SJEW, SJEOW, SJEOW, SOW, SOOW, STW, STOW, STOOW, SEW, SEOW, SEOOW	

Table 115.2 Continued on Next Page

**Table 115.2 Continued**

Description of cord set			
Ratings of fittings used	Length of cord set	Flexible cord used <sup>a</sup>	Ratings of cord set
30 A at 250 V	0 – 50 ft (0 – 15.2 m)	3-conductor 10–2 AWG  SJOW, SJOOW, SJTW, SJTOW, SJTOOW, SJEW, SJEOW, SJEOOW, SOW, SOOW, STW, STOW, STOOW, SEW, SEOW, SEOOW	30 A (7500 W) maximum at 250 V maximum
	over 50 ft (15.2 m)	3-conductor 8–2 AWG  SOW, SOOW, STW, STOW, STOOW, SEW, SEOW, SEOOW	
50 A at 250 V	0 – 50 ft (0 – 15.2 m)	3-conductor 6–2 AWG  SOW, SOOW, STW, STOW, STOOW, SEW, SEOW, SEOOW	50 A (12500 W) maximum at 250 V maximum
	over 50 ft (15.2 m)	3-conductor 4 AWG  SOW, SOOW, STW, STOW, STOOW, SEW, SEOW, SEOOW	

<sup>a</sup> Each of the conductors is of the same size and one is the grounding conductor.

**Table 115.3**  
**Ratings of cord sets 277-V, 2-pole, 3-wire grounding**

Table 115.3 revised March 16, 2001

Description of cord set				
Ratings of fittings used	Length of cord set	Flexible cord used <sup>a</sup>	Ratings of cord set	
15 A at 277 V	over 50 ft (15.2m)	3-conductor 18 AWG  SJOW, SJOOW, SJTW, SJTOW, SJTOOW, SJEW, SJEOW, SJEOW, SOW, SOOW, STW, STOW, STOOW, SEW, SEOW, SEOW	7 A (1939 W) maximum at 277 V maximum	
	0 – 50 ft (0 – 15.2m)	3-conductor 18 AWG  SJOW, SJOOW, SJTW, SJTOW, SJTOOW, SJEW, SJEOW, SJEOW, SOW, SOOW, STW, STOW, STOOW, SEW, SEOW, SEOW	10 A (2770 W) maximum at 277 V maximum	
	over 50 ft (15.2 m)	3-conductor 16 AWG  SJOW, SJOOW, SJTW, SJTOW, SJTOOW, SJEW, SJEOW, SJEOW, SOW, SOOW, STW, STOW, STOOW, SEW, SEOW, SEOW		
	0 – 50 ft ) (0 – 15.2 m)	3-conductor 16 AWG  SJOW, SJOOW, SJTW, SJTOW, SJTOOW, SJEW, SJEOW, SJEOW, SOW, SOOW, STW, STOW, STOOW, SEW, SEOW, SEOW	13 A (3601 W) maximum at 277 V maximum	
	over 50 ft (15.2 m)	3-conductor 14 AWG  SJOW, SJOOW, SJTW, SJTOW, SJTOOW, SJEW, SJEOW, SJEOW, SOW, SOOW, STW, STOW, STOOW, SEW, SEOW, SEOW		
	0 – 50 ft (0 – 15.2 m)	3-conductor 14–2 AWG  SJOW, SJOOW, SJTW, SJTOW, SJTOOW, SJEW, SJEOW, SJEOW, SOW, SOOW, STW, STOW, STOOW, SEW, SEOW, SEOW	15 A (4155 W) maximum at 277 V maximum	
	over 50 ft (15.2 m)	3-conductor 12–2 AWG  SJOW, SJOOW, SJTW, SJTOW, SJTOOW, SJEW, SJEOW, SJEOW, SOW, SOOW, STW, STOW, STOOW, SEW, SEOW, SEOW		
	20 A at 277 V	0 – 50 ft (0 – 15.2 m)	3-conductor 12–2 AWG  SJOW, SJOOW, SJTW, SJTOW, SJTOOW, SJEW, SJEOW, SJEOW, SOW, SOOW, STW, STOW, STOOW, SEW, SEOW, SEOW	20 A (5540 W) maximum at 277 V maximum
		over 50 ft (15.2 m)	3-conductor 10–2 AWG  SJOW, SJOOW, SJTW, SJTOW, SJTOOW, SJEW, SJEOW, SJEOW, SOW, SOOW, STW, STOW, STOOW, SEW, SEOW, SEOW	

Table 115.3 Continued on Next Page

Table 115.3 Continued

Description of cord set			
Ratings of fittings used	Length of cord set	Flexible cord used <sup>a</sup>	Ratings of cord set
30 A at 277 V	0 – 50 ft (0 – 15.2 m)	3-conductor 10–2 AWG  SJOW, SJOOW, SJTW, SJTOW, SJTOOW, SJEW, SJEOW, SJEOOW, SOW, SOOW, STW, STOW, STOOW, SEW, SEOW, SEOOW	30 A (8310 W) maximum at 277 V maximum
	over 50 ft (15.2 m)	3-conductor 8–2 AWG  SOW, SOOW, STW, STOW, STOOW, SEW, SEOW, SEOOW	
50 A at 277 V	0 – 50 ft (0 – 15.2 m)	3-conductor 4–2 AWG  SOW, SOOW, STW, STOW, STOOW, SEW, SEOW, SEOOW	50 A (13850 W) maximum at 277 V maximum
	over 50 ft (15.2 m)	3-conductor 4–2 AWG  SOW, SOOW, STW, STOW, STOOW, SEW, SEOW, SEOOW	

<sup>a</sup> Each of the conductors is of the same size and one is the grounding conductor.

**Table 115.4**  
**Ratings of cord sets 125/250-V, 3-pole, 4-wire grounding**

Table 115.4 revised March 16, 2001

Description of cord set			
Ratings of fittings used	Length of cord set	Flexible cord used <sup>a</sup>	Ratings of cord set
15 A at 125/250 V (3-wire)	0 – 50 ft (0 – 15.2m)	4-conductor 18 AWG  SJOW, SJOOW, SJTW, SJTOW, SJTOOW, SJEW, SJEOW, SJEOW, SOW, SOOW, STW, STOW, STOOW, SEW, SEOW, SEOOW	10 A (2500 W) maximum at 125/250V maximum (3-wire)
	over 50 ft (15.2m)	4-conductor 16 AWG  SJOW, SJOOW, SJTW, SJTOW, SJTOOW, SJEW, SJEOW, SJEOW, SOW, SOOW, STW, STOW, STOOW, SEW, SEOW, SEOOW	
	0 – 50 ft (0 – 15.2m)	4-conductor 16 AWG  SJOW, SJOOW, SJTW, SJTOW, SJTOOW, SJEW, SJEOW, SJEOW, SOW, SOOW, STW, STOW, STOOW, SEW, SEOW, SEOOW	13 A (3250 W) maximum at 125/250 V maximum (3-wire)
	over 50 ft (15.2 m)	4-conductor 14 AWG  SJOW, SJOOW, SJTW, SJTOW, SJTOOW, SJEW, SJEOW, SJEOW, SOW, SOOW, STW, STOW, STOOW, SEW, SEOW, SEOOW	
	0 – 50 ft (0 – 15.2 m)	4-conductor 14–2 AWG  SJOW, SJOOW, SJTW, SJTOW, SJTOOW, SJEW, SJEOW, SJEOW, SOW, SOOW, STW, STOW, STOOW, SEW, SEOW, SEOOW	15 A (3750 W) maximum at 125/250 V maximum (3-wire)
	over 50 ft (15.2 m)	4-conductor 12–2 AWG  SJOW, SJOOW, SJTW, SJTOW, SJTOOW, SJEW, SJEOW, SJEOW, SOW, SOOW, STW, STOW, STOOW, SEW, SEOW, SEOOW	
20 A at 125/250 V (3-wire)	0 – 50 ft (0 – 15.2 m)	4-conductor 12–2 AWG  SJOW, SJOOW, SJTW, SJTOW, SJTOOW, SJEW, SJEOW, SJEOW, SOW, SOOW, STW, STOW, STOOW, SEW, SEOW, SEOOW	20 A (5000 W) maximum at 125/250 V maximum (3-wire)
	over 50 ft (15.2 m)	4-conductor 10–2 AWG  SJOW, SJOOW, SJTW, SJTOW, SJTOOW, SJEW, SJEOW, SJEOW, SOW, SOOW, STW, STOW, STOOW, SEW, SEOW, SEOOW	

Table 115.4 Continued on Next Page



Table 115.4 Continued

Description of cord set			
Ratings of fittings used	Length of cord set	Flexible cord used <sup>a</sup>	Ratings of cord set
30 A at 125/250 V (3-wire)	0 – 50 ft (0 – 15.2 m)	4-conductor 10–2 AWG  SJOW, SJOOW, SJTW, SJTOW, SJTOOW, SJEW, SJEOW, SJEOW, SOW, SOOW, STW, STOW, STOOW, SEW, SEOW, SEOOW	30 A (7500 W) maximum at 125/250 V maximum (3-wire)
	over 50 ft (15.2 m)	4-conductor 8–2 AWG  SOW, SOOW, STW, STOW, STOOW, SEW, SEOW, SEOOW	
50 A at 125/250 V (3-wire)	0 – 50 ft (0 – 15.2 m)	4-conductor 6–2 AWG  SOW, SOOW, STW, STOW, STOOW, SEW, SEOW, SEOOW	50 A (12500 W) maximum at 125/250 V maximum (3-wire)
	over 50 ft (15.2 m)	4-conductor 4–2 AWG  SOW, SOOW, STW, STOW, STOOW, SEW, SEOW, SEOOW	
60 A at 125/250 V (3-wire)	0 – 50 ft (0 – 15.2 m)	4-conductor 4–2 AWG  SOW, SOOW, STW, STOW, STOOW, SEW, SEOW, SEOOW	60 A (15000 W) maximum at 125/250 V maximum (3-wire)
	over 50 ft (15.2 m)	4-conductor 2 AWG  SOW, SOOW, STW, STOW, STOOW, SEW, SEOW, SEOOW	

<sup>a</sup> Each of the conductors is of the same size and one is the grounding conductor.

**Table 115.5**  
**Ratings of cord sets 250-V, 3-pole, 4-wire, 3-phase delta**

Table 115.5 revised March 16, 2001

Description of cord set			
Ratings of fittings used	Length of cord set	Flexible cord used <sup>a</sup>	Ratings of cord set
15 A at 250 V (3-pole, 4-wire, 3-phase delta)	0 – 50 ft (0 – 15.2m)	4-conductor 18 AWG  SJOW, SJOOW, SJTW, SJTOW, SJTOOW, SJEW, SJEOW, SJEOW, SOW, SOOW, STW, STOW, STOOW, SEW, SEOW, SEOOW	7 A (3031 W) maximum at 250 V maximum (3-pole, 4-wire, 3-phase delta)
	over 50 ft (15.2m)	4-conductor 16 AWG  SJOW, SJOOW, SJTW, SJTOW, SJTOOW, SJEW, SJEOW, SJEOW, SOW, SOOW, STW, STOW, STOOW, SEW, SEOW, SEOOW	
	0 – 50 ft (0 – 15.2m)	4-conductor 16 AWG  SJOW, SJOOW, SJTW, SJTOW, SJTOOW, SJEW, SJEOW, SJEOW, SOW, SOOW, STW, STOW, STOOW, SEW, SEOW, SEOOW	10 A (4330 W) maximum at 250 V maximum (3-pole, 4-wire, 3-phase delta)
	over 50 ft (15.2 m)	4-conductor 14 AWG  SJOW, SJOOW, SJTW, SJTOW, SJTOOW, SJEW, SJEOW, SJEOW, SOW, SOOW, STW, STOW, STOOW, SEW, SEOW, SEOOW	
	0 – 50 ft (0 – 15.2 m)	4-conductor 14–2 AWG  SJOW, SJOOW, SJTW, SJTOW, SJTOOW, SJEW, SJEOW, SJEOW, SOW, SOOW, STW, STOW, STOOW, SEW, SEOW, SEOOW	15 A (6495 W) maximum at 250 V maximum (3-pole, 4-wire, 3-phase delta)
	over 50 ft (15.2 m)	4-conductor 12–2 AWG  SJOW, SJOOW, SJTW, SJTOW, SJTOOW, SJEW, SJEOW, SJEOW, SOW, SOOW, STW, STOW, STOOW, SEW, SEOW, SEOOW	
20 A at 250 V (3-pole, 4-wire, 3-phase delta)	0 – 50 ft (0 – 15.2 m)	4-conductor 12–2 AWG  SJOW, SJOOW, SJTW, SJTOW, SJTOOW, SJEW, SJEOW, SJEOW, SOW, SOOW, STW, STOW, STOOW, SEW, SEOW, SEOOW	20 A (8660 W) maximum at 250 V maximum (3-pole, 4-wire, 3-phase delta)
	over 50 ft (15.2 m)	4-conductor 10–2 AWG  SJOW, SJOOW, SJTW, SJTOW, SJTOOW, SJEW, SJEOW, SJEOW, SOW, SOOW, STW, STOW, STOOW, SEW, SEOW, SEOOW	

Table 115.5 Continued on Next Page

Table 115.5 Continued

Description of cord set			
Ratings of fittings used	Length of cord set	Flexible cord used <sup>a</sup>	Ratings of cord set
30 A at 250 V (3-pole, 4-wire, 3-phase delta)	0 – 50 ft (0 – 15.2 m)	4-conductor 8–2 AWG  SOW, SOOW, STW, STOW, STOOW, SEW, SEOW, SEOOW	30 A (12990 W) maximum at 250 V maximum (3-pole, 4-wire, 3-phase delta)
	over 50 ft (15.2 m)	4-conductor 6–2 AWG  SOW, SOOW, STW, STOW, STOOW, SEW, SEOW, SEOOW	
50 A at 250 V (3-pole, 4-wire, 3-phase delta)	0 – 50 ft (0 – 15.2 m)	4-conductor 4–2 AWG  SOW, SOOW, STW, STOW, STOOW, SEW, SEOW, SEOOW	50 A (21650 W) maximum at 250 V maximum (3-pole, 4-wire, 3-phase delta)
	over 50 ft (15.2 m)	4-conductor 4 AWG  SOW, SOOW, STW, STOW, STOOW, SEW, SEOW, SEOOW	
60 A at 250 V (3-pole, 4-wire, 3-phase delta)	0 – 50 ft (0 – 15.2 m)	4-conductor 4–2 AWG  SOW, SOOW, STW, STOW, STOOW, SEW, SEOW, SEOOW	60 A (25980 W) maximum at 250 V maximum (3-pole, 4-wire, 3-phase delta)
	over 50 ft (15.2 m)	4-conductor 2 AWG  SOW, SOOW, STW, STOW, STOOW, SEW, SEOW, SEOOW	

<sup>a</sup> Each of the conductors is of the same size and one is the grounding conductor.

No Text on This Page

## **SUPPLEMENT SA - SUPPLEMENT FOR MARINE SHORE POWER CABLE SETS**

### **SA1 Scope**

SA1.1 These requirements cover marine shore power cable sets rated at not less than 20 A and not more than 50 A, 250 V maximum. Each of the marine shore power cable sets is intended to extend the shore power supply from a shore-installed power outlet to a power inlet on a boat, in accordance with the applicable requirements of the American Boat and Yacht Council (ABYC) Std. E – 8, National Fire Protection Association Standard for Pleasure and Commercial Motor Craft, NFPA No. 302, and the United States Coast Guard (USCG) Regulations Title 33, Chapter 1, CFR, Part 183.

### **SA2 Glossary**

SA2.1 SHORE POWER INLET – A boat-mounted motor attachment plug intended to provide connection for a shore power cable set.

SA2.2 SHORE POWER CABLE SET – A length of flexible cord or cable assembled with a locking-type grounding attachment plug as a line fitting and a locking-type grounding cord connector as a load fitting intended to be used in supplying a-c power to each of the boats that is moored to a dock.

### **SA3 General**

SA3.1 Marine shore power cable sets shall comply with the applicable requirements for outdoor-use cord sets in the Standard for Cord Sets and Power-Supply Cords, UL 817, except as modified by the following requirements. Each of the marine shore power cable sets is intended to be stored where not exposed to sunlight or weather while not in use.

## **CONSTRUCTION**

### **SA4 General**

SA4.1 A nonmetallic material employed for component parts, such as boots, covers, or locking rings, shall be:

- a) Nonhygroscopic,
- b) Resistant to sunlight, thermal aging, and ozone, and
- c) Capable of withstanding tests at minus 35° and plus 85°C (minus 31°C and plus 185°F).

If it is not clear that a component part has the required properties, the applicable tests for exposure to low temperature, exposure to high temperature, ozone resistance, exposure to ultraviolet light and water, or accelerated oven aging in Sections SA13 – SA17 shall be used.

SA4.2 The overall length of a shore power cable set shall be at least 25 ft (7.6 m) but not more than 50 ft (15.2 m).

## SA5 Corrosion Resistance

SA5.1 All current-carrying parts shall be copper alloy. The blades and contacts of fittings shall be provided with a corrosion resistant plating.

SA5.2 Each of the noncurrent-carrying metal parts, such as metal strain-relief clamps that is depended upon to meet the requirements of the standard, shall provide corrosion resistance equal to that of:

- a) Stainless steel Alloys 302, 304, 410, or 430 or
- b) Bronze alloys with less than 15 percent zinc content, and shall be galvanically compatible with other metal parts of the shore power cable set.

SA5.3 If there is any question that the parts are corrosion resistant, the salt spray test in Section SA8 shall be used.

## SA6 Flexible Cord

SA6.1 The flexible cord shall be Type SOW, SOOW, STW, STOW, STOOW, SEW, SEOW, SEOOW, SJOW, SJOOW, SJTW, SJTOW, SJTOOW, SJEW, SJEOW, or SJEOWW. All cord conductors shall be of the same size and shall not be smaller than indicated in Table 30.1. The flexible cord shall contain two, three, or four insulated circuit conductors with an insulated grounding conductor of the same size as the circuit conductors.

SA6.1 revised March 16, 2001

## SA7 Fittings

SA7.1 A shore power cable set shall employ one of the line and load fittings of the locking-grounding types illustrated in Figures C2.4, C2.5, C2.7, C2.8, C2.24 – C2.27, C2.37, C2.38, C2.43, and C2.44.

SA7.2 The construction of a line and load fitting assembly, including any protective covering or boots, shall exclude entrance of moisture where the cord enters the assembly.

SA7.3 To determine compliance with SA7.2, the flexible cord is to be bent to an angle of 90 degrees to the plane of the cord entry and visually examined for openings through which moisture might enter the body. Any opening between the flexible cord and the boot, cover, or body of an attachment plug or cord connector is unacceptable.

*Exception: Each of the molded-on attachment plugs and cord connectors is acceptable if positive adhesion can be demonstrated between the flexible cord and the molded-on body at all points around the periphery of the cord. Representative devices may be cut apart to show the inner construction and the resultant seal between the cord and body.*

SA7.4 A load fitting shall:

- a) Be provided with a threaded coupling ring for attachment to a threaded hub of a shore power inlet that shall be positively retained in place on the load fitting. The coupling ring shall have a 2-3/4 – 16, Class 2 thread having at least three full threads. See Figure SA7.1.
- b) Prevent water from entering between the load fitting and the shore power inlet as determined by the flexure and water-spray test in Section SA10.

c) Be dimensioned to couple with a shore power inlet of a corresponding configuration. See Figure SA7.2 and Table SA7.1 for the required dimensions of cord connectors and shore power inlets.

**Figure SA7.1**  
**Threaded coupling ring**  
**SECTION A-A**

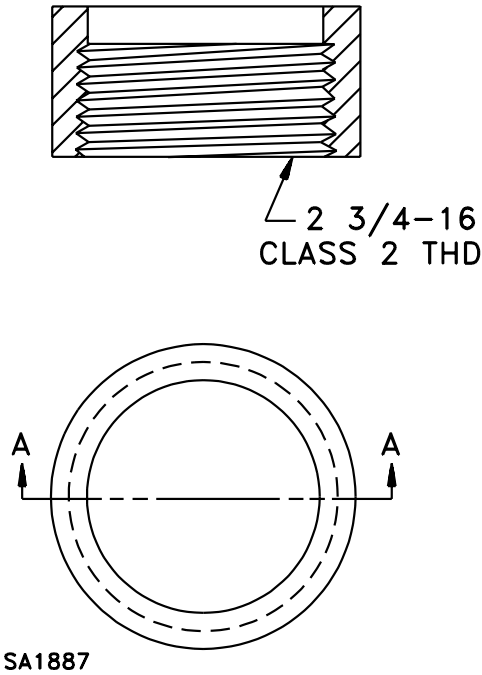

**Table SA7.1**  
**Dimensions for cord connectors and shore power inlets in Figure SA7.2**

ANSI Standard designation	Rating	Shore power inlet <sup>a</sup>		Cord connector <sup>a</sup>		Figure in UL 1681
		A <sup>b</sup>	B	C <sup>d</sup>	D <sup>b</sup>	
WD 6 – L5-20	20A, 125 V, 1 Phase, 2 Pole, 3 Wire	1.880	0.921 <sup>c</sup>	1.860	0.967	C2.4
		(47.75)	(23.39)	(47.24)	(24.56)	
WD 6 – L5-30	30 A, 125 V, 1 Phase, 2 Pole, 3 Wire	1.880	1.000 <sup>c</sup>	1.860	1.046	C2.5
		(47.75)	(25.40)	(47.24)	(26.57)	
WD 6 – L6-20	20 A, 250 V, 1 Phase, 2 Pole, 3 Wire	1.880	0.921 <sup>c</sup>	1.860	0.967	C2.7
		(47.75)	(23.39)	(47.24)	(24.56)	

Table SA7.1 Continued

ANSI Standard designation	Rating	Shore power inlet <sup>a</sup>		Cord connector <sup>a</sup>		Figure in UL 1681
		A <sup>b</sup>	B	C <sup>d</sup>	D <sup>b</sup>	
WD 6 – L6-30	30 A, 250 V, 1 Phase, 2 Pole, 3 Wire	1.880 (47.75)	1.000 <sup>c</sup> (25.40)	1.860 (47.24)	1.046 (26.57)	C2.8
WD 6 – L14-20	20 A, 125/250 V, 1 Phase, 3 Pole, 4 Wire	2.000 (50.80)	0.921 <sup>c</sup> (23.39)	1.980 (50.29)	0.967 (24.56)	C2.24
WD 6 – L14-30	30 A, 125/250 V, 1 Phase, 3 Pole, 4 Wire	2.000 (50.80)	1.000 <sup>c</sup> (25.40)	1.980 (50.29)	1.046 (26.57)	C2.25
WD 6 – L15-20	20 A, 250 V, 3 Phase, 3 Pole, 4 Wire	2.000 (50.80)	0.921 <sup>c</sup> (23.39)	1.980 (50.29)	0.967 (24.56)	C2.26
WD 6 – L15-30	30 A, 250 V, 3 Phase, 3 Pole, 4 Wire	2.000 (50.80)	1.000 <sup>c</sup> (25.40)	1.980 (50.29)	1.046 (26.57)	C2.27
WD 6 – L21-20	20 A, 208Y/120 V, 3 Phase, 4 Pole, 5 Wire	2.000 (50.80)	0.921 <sup>c</sup> (23.39)	1.980 (50.29)	0.967 (24.56)	C2.37
WD 6 – L21-30	30 A, 208Y/120 V, 3 Phase, 4 Pole, 5 Wire	2.000 (50.80)	1.000 <sup>c</sup> (25.40)	1.980 (50.29)	1.046 (26.57)	C2.38
WD 6 – SS1-50 <sup>e</sup>	50 A, 125 V, 1 Phase, 2 Pole, 3 Wire	2.015 (51.18)	1.163 <sup>d</sup> (29.54)	1.991 (50.57)	1.171 (29.74)	C2.43
WD 6 – SS2-50 <sup>e</sup>	50 A, 125/250 V, 1 Phase, 3 Pole, 4 Wire	2.015 (50.18)	1.163 <sup>d</sup> (29.54)	1.991 (50.57)	1.171 (29.74)	C2.44

<sup>a</sup> Dimensions in inches (mm).  
<sup>b</sup> Minimum dimension.  
<sup>c</sup> Tolerance of minus 0, plus 0.031 (plus 0.79 mm).  
<sup>d</sup> Maximum dimension.  
<sup>e</sup> Small-craft.



Figure SA7.2  
Dimensions of cord connectors and shore power inlets

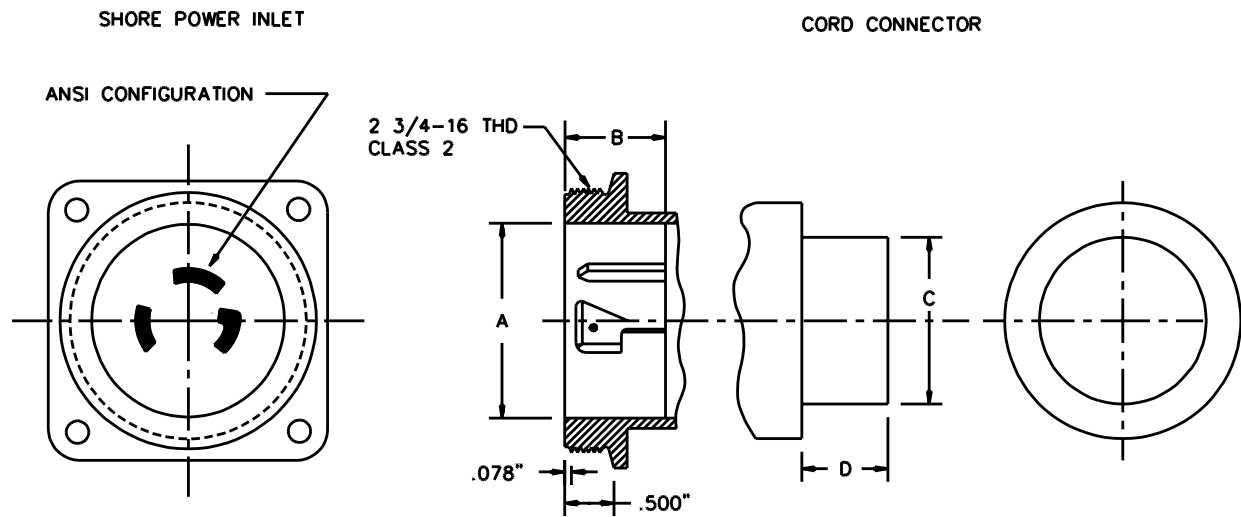

SB1981

## PERFORMANCE

### SA8 Salt Spray Test

SA8.1 If necessary to determine compliance with the corrosion resistance requirement of SA5.3, the shore power cable set shall be exposed to salt spray (fog) for a period of 750 hours. The salt spray exposure shall be conducted in accordance with the Standard Method of Salt Spray (Fog) Testing, ASTM B117. Following the exposure, the cable set shall comply with the mechanical strength, flexure and water-spray, insulation resistance, and dielectric voltage-withstand tests in Sections SA9 – SA12.

## **SA9 Mechanical Strength Test**

SA9.1 A representative shore power cable set of the maximum length shall be tested as described in SA9.2 without external physical damage to the component parts. A maximum-length shore power cable set is the longest one produced by a particular manufacturer but not exceeding the 50 ft (15.2 m) maximum length specified in SA4.2.

SA9.2 A maximum-length shore power cable set shall be installed as shown in Figure SA9.1, connected at one end to a power inlet and to a power outlet at the other end. The excess cord of the shore power cable set shall be coiled between the power outlet and inlet and taped at the base of the coil. During the test, the shore power cable set shall be free to move without striking any surface. The platform shall be rotated to cause the mounted power inlet to move back and forth in a vertical direction through an angle of 30 degrees (15 degrees above and below the horizontal) for a total of 1000 cycles. The rate shall be 15 cycles per minute.

SA9.3 After completion of the 1000 cycles, the shore power cable set components shall be visually examined for damage including cracking of the insulation materials, boots, and covers.

## **SA10 Flexure and Water Spray Test**

SA10.1 Load fittings shall be tested as described in SA10.2– SA10.5 to determine that their constructions keep water from reaching current-carrying parts.

SA10.2 The shore power cable set shall be installed as shown in Figure SA10.1 with its load fitting connected to a power inlet mounted on a vertical wall section. The excess length of flexible cord shall be coiled on the floor.

SA10.3 While connected to the power inlet, the shore power cable set is to be sprayed with water from the apparatus described in SA10.4. The test shall last 1 hour during which time the shore power cable set shall be flexed at a rate of 6 cycles per minute. Each cycle is to consist of the movement of the cable set from its starting position, through the positions resulting from pulling on the rope for a distance of 16 inches (406 mm), then releasing the rope and allowing the cable set to fall to its natural resting position below the starting position, and then pulling on the rope until the cable set is returned to the starting position. See Figure SA10.1.

SA10.4 The water-spray apparatus is to consist of three spray heads mounted in a water-supply pipe rack as illustrated in Figure SA10.2. Spray heads are to be constructed in accordance with Figure SA10.3. The water-supply pipe rack with spray heads is to be located so that the focal point of the spray is at the load fitting of the shore power cable set. The water pressure is to be maintained at 5 lbs/in<sup>2</sup> (34 kPa) at each spray head.

SA10.5 The load fitting shall then be disconnected from the power inlet and examined to determine that water has not reached current-carrying parts.

Figure SA9.1  
Mechanical strength test apparatus

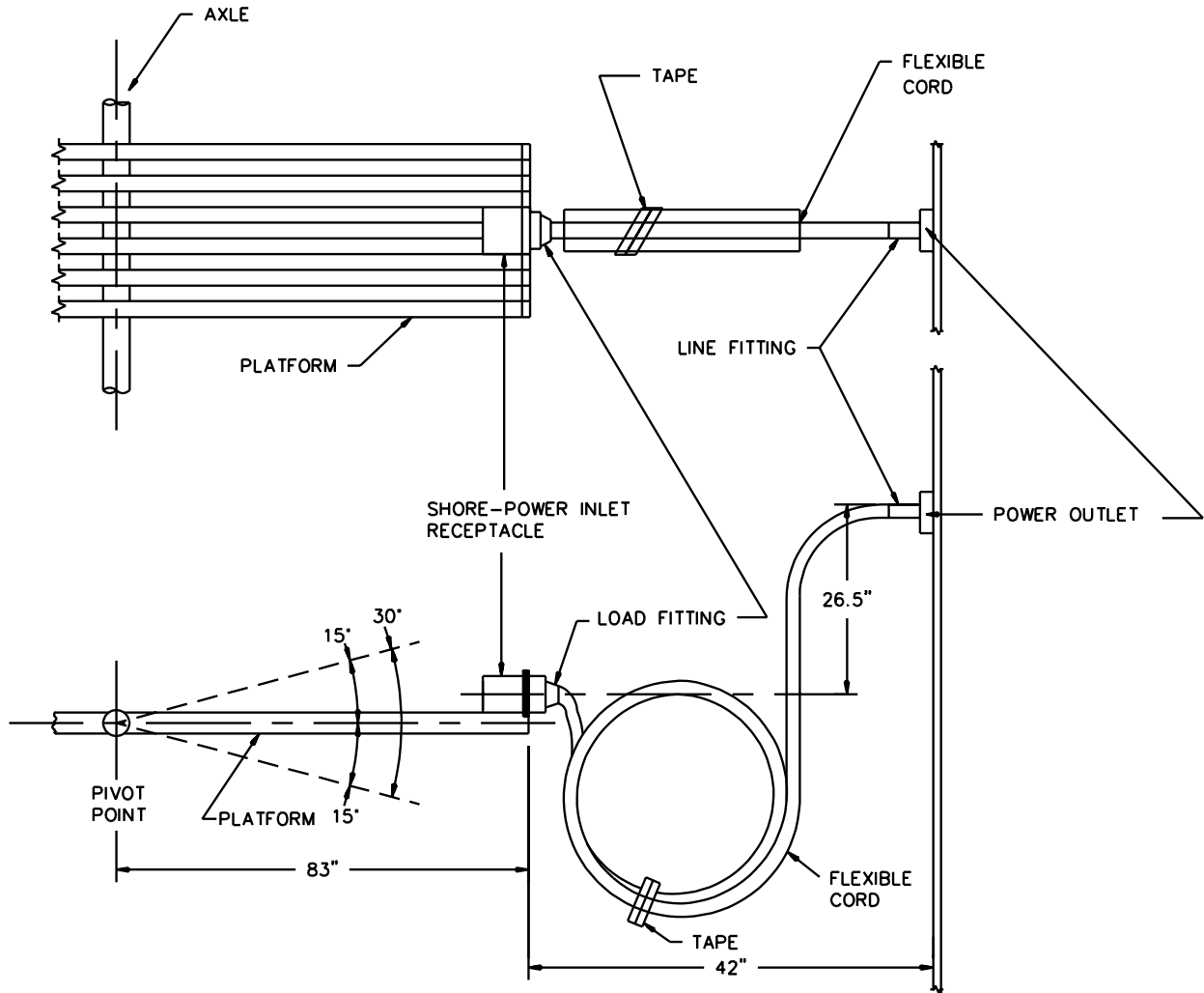

SB1968

Inch	26.5	42	83
mm	673	1067	2108

Figure SA10.1  
Flexure and water-spray test apparatus (Start position)

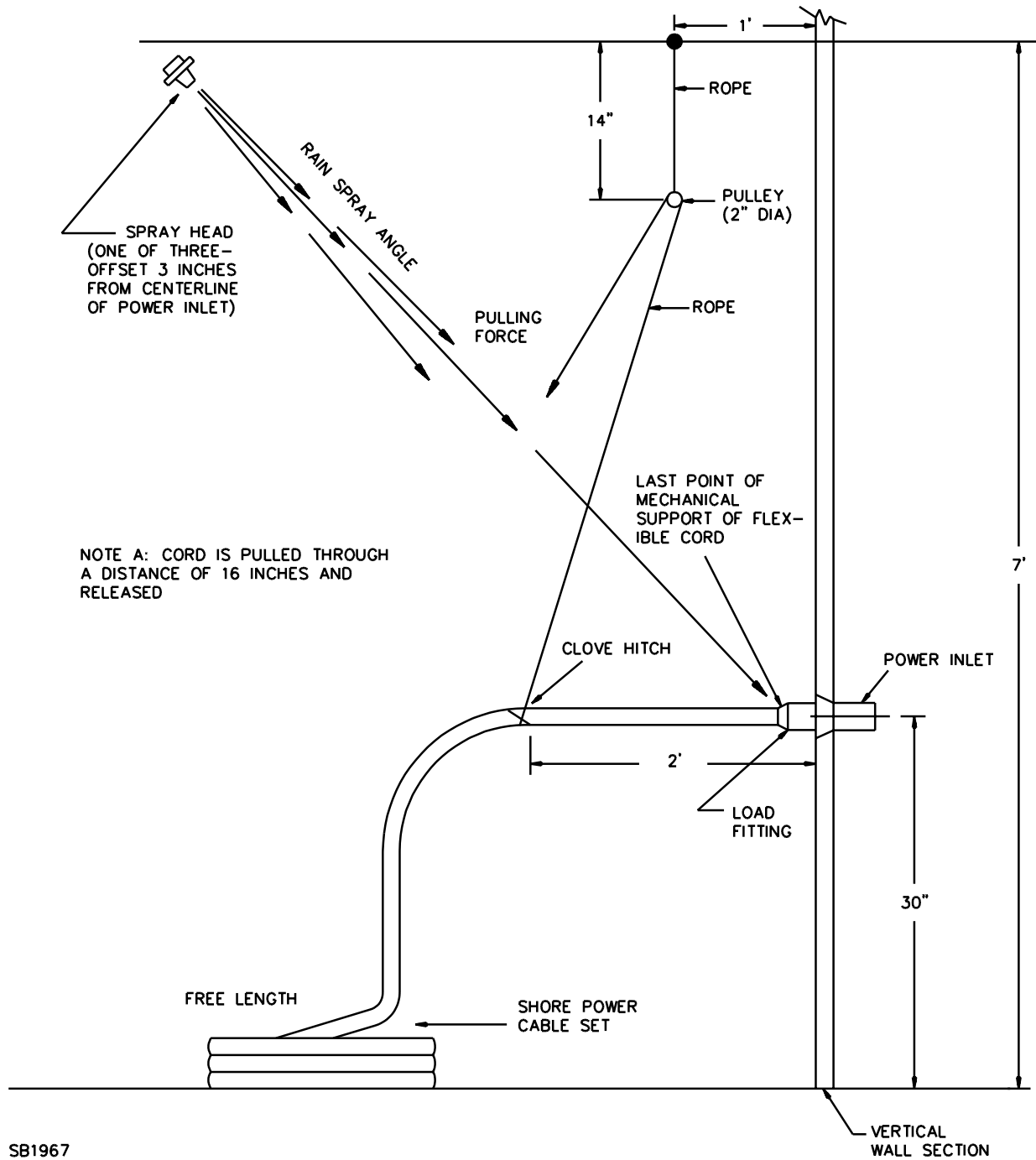

Inch	2	3	14	16	30	Feet	1	2	7
mm	51	76	356	406	762	m	0.31	0.61	2.13

Figure SA10.2  
Water-spray-head piping  
PLAN VIEW

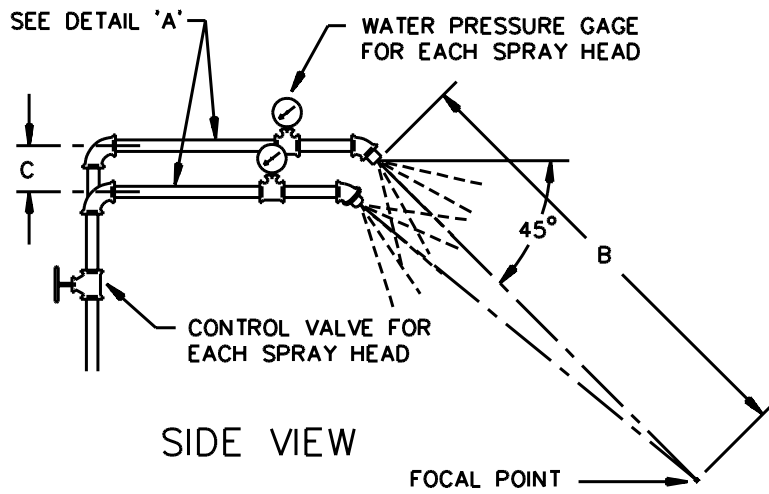
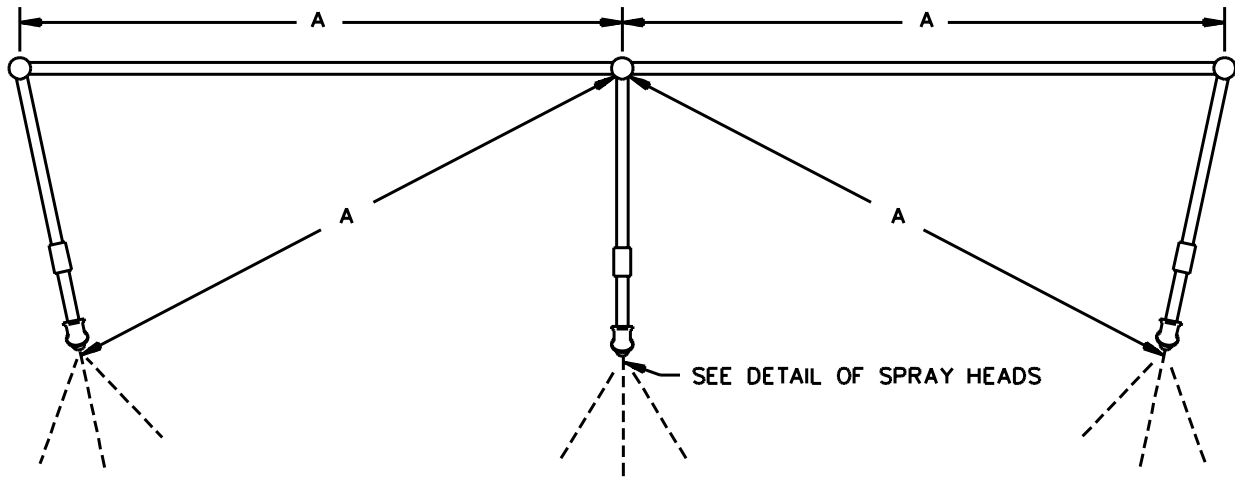

PIEZOMETER ASSEMBLY  
DETAIL 'A'

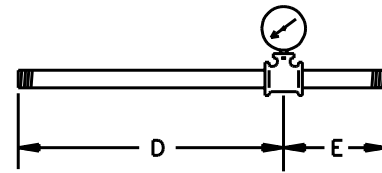

SIDE VIEW

RT101B

Item	inch	mm
A	28	711
B	55	1397
C	2-1/4	57
D	9	229
E	3	76

Figure SA10.3  
Water-spray head

ASSEMBLY<sup>a</sup>

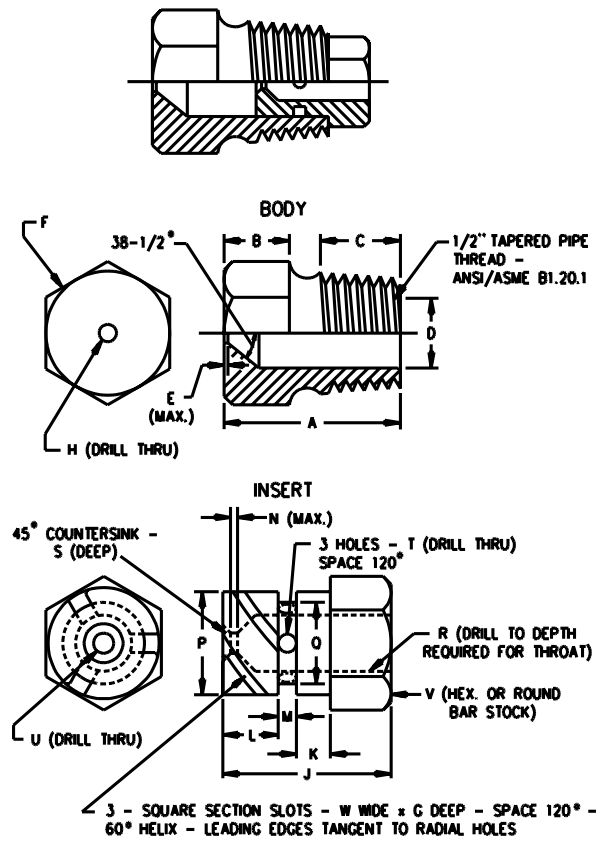

Item	inch	mm	Item	inch	mm
A	1-7/32	31.0	N	1/32	0.80
B	7/16	11.0	P	.575	14.61
C	9/16	14.0	Q	.576	14.63
D	.578	14.68	R	.453	11.51
E	.580	14.73	S	.454	11.53
F	1/64	0.40	T	1/4	6.35
G	c	c	U	1/32	0.80
H	.06	1.52	V	(No. 35) <sup>b</sup>	2.80
I	(No. 9) <sup>b</sup>	5.0	W	(No. 40) <sup>b</sup>	2.50
J	23/32	18.3			
K	5/32	3.97			
L	1/4	6.35			
M	3/32	2.38			

<sup>a</sup> Nylon Rain-Test Spray Heads are available from Underwriters Laboratories

<sup>b</sup> ANSI B94.11M Drill Size

<sup>c</sup> Optional - To serve as a wrench grip.

RT100E

**SA11 Insulation Resistance Test**

SA11.1 Following the mechanical-strength and the flexure and water-spray tests described in Sections SA9 and SA10, a shore power cable set shall have an insulation resistance between conductors that is not less than 90 percent of the "as received" value when determined in accordance with Insulation Resistance Test, Section 89.

**SA12 Dielectric Voltage-Withstand Test**

SA12.1 A shore power cable set, after being subjected to the mechanical-strength and the flexure and water-spray tests described in Sections SA9 and SA10, shall acceptably withstand the 1-minute application of a 1250-V, 60-Hz potential as described in Dielectric Voltage Withstand Tests, Section 88.

**SA13 Exposure to Low Temperature Test**

SA13.1 Following the low-temperature conditioning and impact described in this section, a fitting with boot shall not have any permanent damage such as distortion of the boot or fitting, or cracking or splitting of the nonmetallic material.

SA13.2 An assembly consisting of a boot and its associated line or load fitting is to be capable of withstanding an impact of 5 lb/ft (6.8 N·m) after exposure to a temperature of minus  $35.0 \pm 3.0^{\circ}\text{C}$  (minus  $31.0 \pm 5.4^{\circ}\text{F}$ ) for 72 hours. Each of three representative assemblies is to be tested. At the end of the 72 hours, each fitting with boot is to be removed from the cold chamber with cotton gloves, connected to a mating device mounted to a fixed vertical wall, and subjected to a single 5 lb/ft (6.8 N·m) impact within 30 seconds after removal from the chamber.

SA13.3 The impact is to be applied from any direction in a plane perpendicular to the center axis of the line or load fitting.

SA13.4 The impact is to be produced by dropping a steel sphere 2 inches (51 mm) in diameter and weighing approximately 1.18 lb (535 g) from a height of 51 inches (1295 mm). For contact with the top surface, the sphere may be allowed to free fall through the 51 inches (1295 mm). For contact with surfaces other than the top, the steel sphere is to be suspended by a cord and allowed to swing as a pendulum dropping through a vertical distance of 51 inches (1295 mm).

**SA14 Exposure to High Temperature Test**

SA14.1 Following the high-temperature conditioning and impact described in this Section, a fitting with boot shall not have any permanent damage, such as distortion of the boot or fitting, or cracking or splitting of the nonmetallic material.

SA14.2 An assembly consisting of a boot and its associated line or load fitting is to be capable of withstanding an impact of 5 lb/ft (6.8 N·m) after an exposure to a temperature of  $85 \pm 3^{\circ}\text{C}$  ( $185 \pm 5.4^{\circ}\text{F}$ ) for a period of 72 hours. Each of three representative assemblies is to be tested. At the end of 72 hours, each fitting with boot shall be removed from the oven, connected to a mating device mounted to a fixed vertical wall, and subjected to a single 5 lb/ft (6.8 N·m) impact within 30 seconds after removal from the oven.

SA14.3 The impact is to be applied as described in SA13.3 and SA13.4.

**SA15 Ozone Resistance Test**

SA15.1 Compliance with the ozone-resistance requirement in SA4.1 shall be demonstrated by the absence of any permanent damage such as distortion of the boot or fitting, or cracking or splitting of the nonmetallic material, following the exposure to ozone and subsequent impact described in this Section.

SA15.2 Each of three representative devices of a nonmetallic boot, ring, or cover with its associated line or load fitting shall be exposed for 70 hours to an ozone concentration of  $50 \pm 5$  ppm at a temperature of  $40 \pm 1^{\circ}\text{C}$  ( $104 \pm 1.8^{\circ}\text{F}$ ). At the end of the 70 hours, each representative device shall be connected to a mating device mounted to a fixed vertical wall and then subjected to a single 5 lb/ft (6.8 N·m) impact.

SA15.3 The impact is to be produced as described in SA13.3 and SA13.4.

**SA16 Exposure to Ultraviolet and Water Test**

SA16.1 Compliance with the moisture and sunlight-resistance requirement in SA4.1 shall be demonstrated by the absence of any permanent damage, such as distortion of the boot or fitting, or cracking or splitting of the nonmetallic material, following the exposure to ultraviolet light and water spray, and subsequent impact, described in this section.

SA16.2 Each of three representative devices of a nonmetallic boot, ring, or cover with its associated line or load fitting shall be exposed for 720 hours to ultraviolet light and water spray as described in SA16.4. At the end of 720 hours, each representative device shall be connected to a mating device mounted to a fixed vertical wall and then subjected to a single 5 lb/ft (6.8 N·m) impact.

SA16.3 The impact is to be produced as described in SA13.3 and SA13.4.

SA16.4 The parts are to be exposed in a Type D or DH Twin enclosed carbon-arc lamp apparatus as described in the Standard Practice for Operating Light-Exposure Apparatus (Carbon-Arc Type) With and Without Water for Exposure of Nonmetallic Materials, ASTM G23. The cycle shall consist of 17 minutes of exposure to ultraviolet light only followed by 3 minutes of ultraviolet light plus water-spray exposure.



**SA17 Accelerated Air Oven Aging Test**

SA17.1 Compliance with the thermal-aging resistance requirement in SA4.1 shall be demonstrated by having each specimen retain at least 80 percent of its initial tensile strength and 50 percent of its initial elongation properties following the air-oven conditioning described in this Section.

SA17.2 Components constructed of rubber compounds or similar material are to be exposed to an air temperature of  $100 \pm 2^{\circ}\text{C}$  ( $212 \pm 3.6^{\circ}\text{F}$ ) for 70 hours in accordance with SA17.5.

SA17.3 Each of three specimens is to be cut using Die C as described in the Standard Test Methods for Vulcanized Rubber and Thermoplastic Rubbers and Thermoplastic Elastomers—Tension, ASTM D412.

SA17.4 A power-driven buffing machine (grinding wheel) shall be used for buffing off irregularities on representative devices from which die-cut specimens are prepared. The abrasive wheel is to be of about No. 36 grit (particle size of 0.019 inch or 0.483 mm). The diameter and rotary velocity of the wheel are to result in a peripheral speed of 4000 – 5000 ft/minute (20.3 – 25.4 m/s). The machine shall be provided with a slow-feed feature so that very little compound is removed during each cut, thereby not overheating the specimen.

SA17.5 The apparatus and test method used for accelerated aging of specimens is described in the Standard Test Method for Rubber-Deterioration in an Air Oven, ASTM D573. Air within the aging chamber is to be circulated at a high velocity. Each of the exhaust ports of the oven is to be adjusted so that fresh air is added at a minimum rate of 200 changes/hour. The blower or other means for circulating the air is to be located entirely outside the aging chamber.

**INSTRUCTIONS****SA18 Instruction Manual**

SA18.1 A pamphlet, booklet, or flyer sheet shall be provided with each shore power cable set containing instructions for proper use, care, and storage of the shore power cable set.

No Text on This Page

## SUPPLEMENT SB - FOR SEASONAL-USE CORD SETS

### INTRODUCTION

#### SB1 Scope

SB1.1 The requirements of this supplement cover seasonal-use cord sets that are only intended for indoor use with Christmas-tree and other seasonal decorative-lighting outfits.

### CONSTRUCTION

#### SB2 General

SB2.1 A seasonal-use cord set shall comply with all of the applicable construction requirements for general-use cord sets in Sections 6 – 14, 16 – 21, and 24– 26 of this standard, UL 817, except as modified by the requirements of this supplement. The male and female fittings of a seasonal-use cord set shall also comply with the applicable construction requirements of the Standard for Attachment Plugs and Receptacles, UL 498.

SB2.2 A seasonal-use cord set shall not exceed 15 feet (4.6 m) in length when measured in accordance with 6.4 of this Standard.

#### SB3 Flexible Cord

SB3.1 The flexible cord used in a seasonal-use cord set shall be of the size and type in Table SB3.1. The cord shall comply with the Standard for Flexible Cord and Fixture Wire, UL 62 and shall have a minimum flame rating of VW-1 and minimum insulation temperature of 105°C (221°F).

**Table SB3.1**  
**Flexible cord and overcurrent protection for seasonal-use cord sets**

Wire size		Wire type	Maximum overcurrent protector rating (A)
AWG	(mm <sup>2</sup> )		
18	(0.82)	SP-2, SPT-2, SPE-2, SV, SVO, SVOO, SVT, SVTO, SVTOO, SVE	5
17	(1.0)	SV, SVO, SVOO, SVT, SVTO, SVTOO, SVE	8
16	(1.3)	SP-2, SPT-2, SPE-2	10

**SB4 Fittings**

SB4.1 An attachment plug, cord connector, or current tap provided on a seasonal-use cord set shall be of the 2-pole, 2-wire polarized configuration shown in Figure C1.1 of the Standard for Wiring Device Configurations, UL 1681.

SB4.2 A seasonal-use cord set employing an outlet fitting (a cord connector connected between the end fittings) shall comply with all of the following:

- a) There shall not be more than a total of 9 outlets (including those provided at the end fittings);
- b) There shall not be more than 3 feet (0.9 m) of flexible cord between each of the outlet fittings;
- c) The outlet fittings shall be factory-assembled to the flexible cord and shall not be field-rewireable; and
- d) Insulating outlet closures that comply with 26.7.1 – 26.7.4 of this standard shall be provided for each outlet opening of each outlet fitting provided between the end fittings of the cord set.

SB4.3 All fittings of a seasonal-use cord set shall comply with the spacings requirements in the Standard for Attachment Plugs and Receptacles, UL 498.

SB4.4 The insulating materials used in the line and load fittings of a seasonal-use cord set shall comply with the flammability requirements for enclosures in Enclosures, Section 10 of the Standard for Seasonal and Holiday Decorative Products, UL 588 and with the high-current arc resistance to ignition (HAI), hot wire resistance to ignition (HWI), comparative tracking index (CTI), and relative thermal index (RTI) requirements of the Standard for Attachment Plugs and Receptacles, UL 498.

**SB5 Fittings Intended to Accommodate Fuses or Other Overcurrent Protective Devices**

SB5.1 The enclosure of an overcurrent protective device shall comply with the material requirements in SB4.4.

SB5.2 A fused attachment plug or current tap shall be constructed so that there shall not be exposure of live parts during removal or replacement of the fuse, nor exposure of live parts with the fuse cover partially open while the plug or current tap is inserted 0.08 inch (2.03 mm) into a receptacle. Exposure of live parts shall be determined by contact with the accessibility probe illustrated in Figure 9.1 of the Standard for Seasonal and Holiday Decorative Products, UL 588. The fuse cover of a fused attachment plug or current tap shall not be detachable from the device.

**SB6 Overcurrent Protection**

SB6.1 A seasonal-use cord set shall be provided with integral overcurrent protection (short circuit and overload protection) rated in accordance with Table SB3.1.

SB6.2 The integral overcurrent protective device shall also comply with the Standards for Low-Voltage Fuses – Part 1: General Requirements, UL 248-1, and Low-Voltage Fuses – Part 14: Supplemental Fuses, UL 248-14.

SB6.3 The overcurrent protective device shall be an integral part of the line fitting (attachment plug or current tap).

SB6.4 A seasonal use cord set shall employ only one overcurrent protective device, which shall be connected to the ungrounded (narrow) blade of the attachment plug or current tap.

**PERFORMANCE****SB7 General**

SB7.1 In addition to the applicable performance requirements for cord sets in Sections 80– 102 of this standard, except as modified by Tests on Female Devices, Section SB8; Conductor Secureness Test, Section SB9; Strain Relief Test, Section SB10; Crushing Test, Section SB11; and Overcurrent Protective Devices, Section SB12; a seasonal-use cord set shall comply with the applicable tests in the Standard for Attachment Plugs and Receptacles, UL 498, as described in Table SB7.1 and the tests in the Standard for Seasonal and Holiday Decorative Products, UL 588, as described in Table SB7.2.

**Table SB7.1**  
**Tests from the Standard for Attachment Plugs and Receptacles, UL 498**

Wiring device		UL 498 Section	Test
All devices		60	Comparative Tracking Index Test
		61	Glow Wire Test
		62	High-Current Arc Resistance to Ignition Test
		63	Mold Stress Relief Test
		64	Moisture Absorption Resistance Test
		65	Dielectric Withstand Test
		68	Conductor Secureness Test
Attachment plugs	All	69	General
		71	Secureness-Of-Cover Test
		76	Terminal Temperature Test
	Pin-type terminals	78	Assembly Test
		79	Temperature Test
		80	Strain Relief Test
		81	Fault Current Test
		82	Dielectric Voltage-Withstand Test

Table SB7.1 Continued on Next Page

Table SB7.1 Continued

Wiring device		UL 498 Section	Test
Cord connectors	All	89	General
		90	Retention of Plugs Tests
		91	Overload Tests
		92	Temperature Test
		93	Resistance to Arcing Test
	Pin-type terminals	97	Assembly Test
		98	Temperature Test
		99	Strain Relief Test
		100	Fault Current Test
		101	Dielectric Voltage-Withstand Test
Current taps	All	150	General
		152	Secureness-Of-Cover Test
		155	Contact Security Test
		157	Retention of Plugs Test
		158	Overload Test
		159	Temperature Test
		160	Resistance to Arcing Test
	Pin-type terminals	163	Assembly Test
		164	Temperature Test
		165	Strain Relief Test
		166	Fault Current Test
		167	Dielectric Voltage-Withstand Test

Table SB7.2

## Tests from the Standard for Seasonal and Holiday Decorative Products, UL 588

UL 588 Section	Test
40	Leakage Current Test
41	Leakage Current Following Humidity Conditioning
54	Temperature Tests for Devices Employing Insulation-Piercing Terminals
58	Enclosure Mold Stress Relief Test
59	Drop Test
60	Impact Test
63	Adhesive Test
67	Fuseholder Temperature Test
69	Fuseholder Cover Test
71	Strain Relief Test
72	Reliability of Conductor Connections Test
90	Flexing Test
91	Temperature Test After Flexing

**SB8 Tests on Female Devices**

SB8.1 Instead of the Tests on Female Devices, Section 80 of UL 817, female devices shall be tested in accordance with Table SB7.1.

**SB9 Conductor Secureness Test**

SB9.1 Instead of the Conductor Secureness Test, Section 81 of UL 817, a device shall comply with the Reliability of Conductor Connections Test, Section 70, of the Standard for Seasonal and Holiday Decorative Products, UL 588. See also Table SB7.2.

**SB10 Strain Relief Test**

SB10.1 Instead of the Strain Relief Test, Section 84 of UL 817, a seasonal-use cord set shall comply with the Strain Relief Test, Section 69, of the Standard for Seasonal and Holiday Decorative Products, UL 588.

**SB11 Crushing Test****SB11.1 General**

SB11.1.1 After being tested as described in this section, a fitting shall comply with each of the following:

- a) There shall not be any visible damage to any part of the fitting that would result in the exposure of live parts as determined by contact with the accessibility probe illustrated in Figure 9.1 of the Standard for Seasonal and Holiday Decorative Products, UL 588;
- b) There shall not be any cracking or denting of the fitting that would make it unfit for use, or affect the function of any safety controls or constructional features such as overcurrent protective devices, strain relief, or similar features; and
- c) There shall not be any damage to the fitting that would result in an increase in the risk of electric shock as determined by compliance with the Dielectric Voltage-Withstand Test, Section 45, of the Standard for Seasonal and Holiday Decorative Products, UL 588.

**SB11.2 Molded-on fittings**

SB11.2.1 After being conditioned in a circulating-air oven for 7 days at  $90.0 \pm 1.0^\circ\text{C}$  ( $194.0 \pm 1.8^\circ\text{F}$ ) and then cooled to room temperature, each of two representative molded-on fittings is to be subjected for 1 minute to a crushing effort of 75 lbf (334 N) applied in any direction at right angles to its major axis.

SB11.2.2 Any testing equipment that can apply a steady pressure of 75 lbf (334 N) to the fitting may be employed. The fitting is to be tested between two 1/2-inch (12.7 mm) or thicker parallel flat maple blocks. Care is to be taken that the crushing force is not applied suddenly.

SB11.2.3 The test in SB11.2.1 and SB11.2.2 is to be repeated on two separate representative fittings, except that the force is to be applied in a direction normal to its mounting surface. One block is to contain slots into which the blades of the fitting, if provided, are to be fully inserted.

### **SB11.3 All other fittings**

SB11.3.1 Each of two representative fittings is to be subjected for 1 minute to a crushing effort of 75 lbf (334 N) applied in a direction normal to its mounting surface.

SB11.3.2 Any testing equipment that can apply a steady pressure of 75 lbf (334 N) to the fitting may be employed. The fitting is to be tested between two 1/2 inch (12.7 mm) or thicker parallel flat maple blocks. One block is to contain slots into which the blades of the fitting, if provided, are to be fully inserted. Care is to be taken that the crushing force is not applied suddenly.

### **SB12 Overcurrent Protective Devices**

SB12.1 The tests in Overcurrent Protective Devices, Section 101, are to be conducted using the largest fuse the fuseholder will accommodate. The test currents are to be based on the rating of the fuse but in no case shall be greater than 22 A.

## **RATING**

### **SB13 General**

SB13.1 The current rating of a seasonal-use cord set shall be determined by the ampere rating of the overcurrent protector provided in the line fitting (attachment plug or current tap).

SB13.2 Each load fitting (cord connector or current tap outlet) shall be rated for the full current rating of the seasonal-use cord set.

SB13.3 A switch provided in a seasonal-use cord set shall be either an AC-only rated general-use snap switch or a general-use AC/DC "T" rated switch that complies with the Standard for General-Use Snap Switches, UL 20. The electrical (tungsten) rating of the switch shall be greater than or equal to the overcurrent protector rating.

## **MARKING**

### **SB14 General**

SB14.1 A seasonal-use cord set shall be marked with its electrical rating in amps (see SB13.1), volts, and watts, on a tag or label of the type described in 23.6 of this standard.

SB14.2 The surface of a fused plug or current tap on a seasonal-use cord set shall be marked "Use only with a fuse rated \_\_\_\_ Amps, 125 Volts." The blank is to be filled in with the maximum overcurrent protector rating determined in accordance with Table SB3.1.

SB14.3 A seasonal-use cord set shall be provided with a single tear-resistant, permanently-attached cord tag that complies with the requirements in 23.14 – 23.16, except that the text of the tag shall be in accordance with Figure SB14.1. The tag also incorporates the applicable markings from Markings, Section 27, so a separate tag is not needed.



Figure SB14.1  
Marking tag

  
**DANGER: ELECTRICAL  
CORDS CAN BE  
HAZARDOUS**

Misuse Can Result In FIRE or DEATH  
by ELECTRICAL SHOCK  
Please Read BOTH SIDES Carefully and  
Follow All Directions.

**BEFORE USE**

- Use Only With Christmas-Tree and Other Seasonal-Use Lighting Products.
- For Temporary Use Only (Not to Exceed 90 Days).
- **FOR INDOOR USE ONLY.**
- Inspect Thoroughly Before Each Use.  
**DO NOT USE IF DAMAGED.**
- This Cord is Rated \_\_\_ **Amps**. The Total of All **Amps** on Items Plugged Into This Cord **SHOULD NOT EXCEED** This Number.
- Do Not Run Through Doorways, Holes in Ceilings, Walls or Floors.
- **FULLY INSERT** Plug Into Outlet.
- Do Not Remove, Bend or Modify Any Metal Prongs or Pins of Cord.
- Do Not Use Excessive Force to Make Connections.
- Do Not Connect  a Three-Prong Plug to a Two-Hole Cord.



**THIS IS A POLARIZED CORD**

SM401A

  
**DANGER: ELECTRICAL  
CORDS CAN BE  
HAZARDOUS**

Misuse Can Result In FIRE or DEATH  
by ELECTRICAL SHOCK  
Please Read BOTH SIDES Carefully and  
Follow All Directions.

**DURING USE**

- Keep Away From Water.
- **DO NOT USE WHEN WET.** 
- Do Not Use on Trees Having Needles, Leaves, Branch Coverings of Metal or Materials Which Look Like Metal.
- Do Not Mount or Support Cord Set or Strings in a Manner That Can Cut or Damage Wire Insulation.
- Keep Children and Pets Away From Cord.
- Cover All Unused Outlets.
- Do Not Plug One Extension Cord Into Another
- **AVOID OVERHEATING.** Uncoil Cord and Do Not Cover It With Any Material.
- Do Not Drive, Drag or Place Objects Over Cord.
- Do Not Walk on Cord.
- Always Unplug When Replacing Fuses. 

**AFTER USE**

- **GRASP PLUG** to Remove From Outlet
- Always Store Cord **INDOORS.**
- Always Unplug When Not In Use.
- Do Not Unplug By  Pulling On Cord.

**DO NOT REMOVE THIS TAG**

## PACKAGING AND USE INSTRUCTIONS

### SB15 General

SB15.1 In addition to the markings required by 23.12, a seasonal-use cord set shall contain all of the following or equivalent statements (following the word CAUTION) on the outer surface of the smallest unit package or on a stuffer sheet or tag (or its equivalent):

- a) "Indoor Use Only";
- b) "CAUTION – Risk of Fire. Not for permanent installation. Use only with a total of \_\_\_\_ Amps maximum Christmas-tree or other seasonal lighting products. Do not install or use this product for more than a 90 day period per year." The blank is to be filled in with the number of Amps based on the maximum overcurrent protector rating in Table SB3.1;
- c) "This is a POLARIZED cord set. It has a polarized plug (one blade is wider than the other) and polarized outlets (one slot is longer than the other). The polarized plug is not intended to be mated with nonpolarized outlets (having both slots the same size). A polarized outlet is intended to mate with a polarized plug in only one way (the longer slot with the wider blade).";
- d) "CAUTION – Risk of Electric Shock. Do not allow cord near wet area, water or water container at base of tree."; and
- e) "If using Christmas tree or decorative-lighting products that are not marked with an ampere rating, connect no more than \_\_\_\_ screw-base lamps (C7 or C9) or \_\_\_\_ strings with midget (push-in) lamps to this cord set." The blank is to be filled in with the appropriate number of lamps and strings as specified in Table SB15.1.

**Table SB15.1**  
**Maximum number of connected products**

Cord set current rating (A)	Max no. of C7 or C9 lamps	Max no. of midget strings
3	30	3
4	45	4
5	60	5
6	70	6
7	80	7
8	95	8
9	105	9
10	125	10

**January 14, 2004**  
**Superseded requirements for**  
**the Standard for**  
**Cord Sets and Power-Supply Cords**

**UL 817, Eleventh Edition**

The requirements shown are the current requirements that have been superseded by requirements in revisions issued for this standard. To retain the current requirements, do not discard the following requirements until the future effective dates are reached.

41.1 (41.1) Each adapter cord set shall be legibly marked with all of the following:

- a) The type letter designation for the cord shall appear on the cord jacket. See 30.1.
- b) The word “outdoor” may also appear on the jacket. See 30.3.
- c) The electrical ratings (see Ratings, Section 40).
- d) The wording “Suitable for use with outdoor appliances – store indoors while not in use” (see 35.1(d) and 35.2).

41.1 effective until June 24, 2006

67.3 (67.3) Detachable power-supply cords intended for shipment to original equipment manufacturers shall have any applicable markings (see General, Section 15; Markings, Section 67; and Markings, Section 79) provided on the outer surface of the shipping carton, or on a tag or the equivalent inside the carton. The electrical rating need not be marked.

67.3 effective until June 24, 2006

No Text on This Page