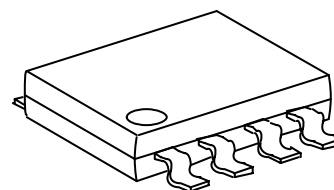
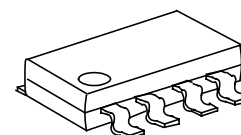
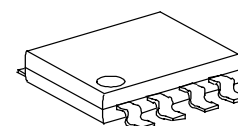

BOOST CONVERT CONTROL IC**GENERAL DESCRIPTION**

The **FP5138** is a boost topology switching regulator control IC for battery-used applications field. The FP5138 includes a totem-pole single output stage for driving NPN transistor or N-MOS, high precision reference (0.5V) for comparing output voltage with feedback amplifier, an internal dead-time control for controlling the minimum duty cycle, programmable soft start with short circuit protection function and logic level control for operating mode or standby mode.

FEATURES

- Wide supply voltage operating range: 1.8 to 15V
- Reference voltage precision: 4%
- Low current consumption: Operation Mode 5.5mA
Standby-by Mode 1 μ A
- High speed oscillator frequency: 1MHz max.
- Programmable Soft Start function (SS)
- Short Circuit Protection function(SCP)
- Totem-pole output with adjustable on/off current
(for NPN transistors or n-channel MOSFET)
- Logic level control stand-by mode function
- Package: SOP8/TSSOP8/MSOP8/SOP8(EP)

**SOP8****TSSOP8****MSOP8****TYPICAL APPLICATION**

- Digital Camera
- PDA
- Portable Equipment

FUNCTIONAL BLOCK DIAGRAM

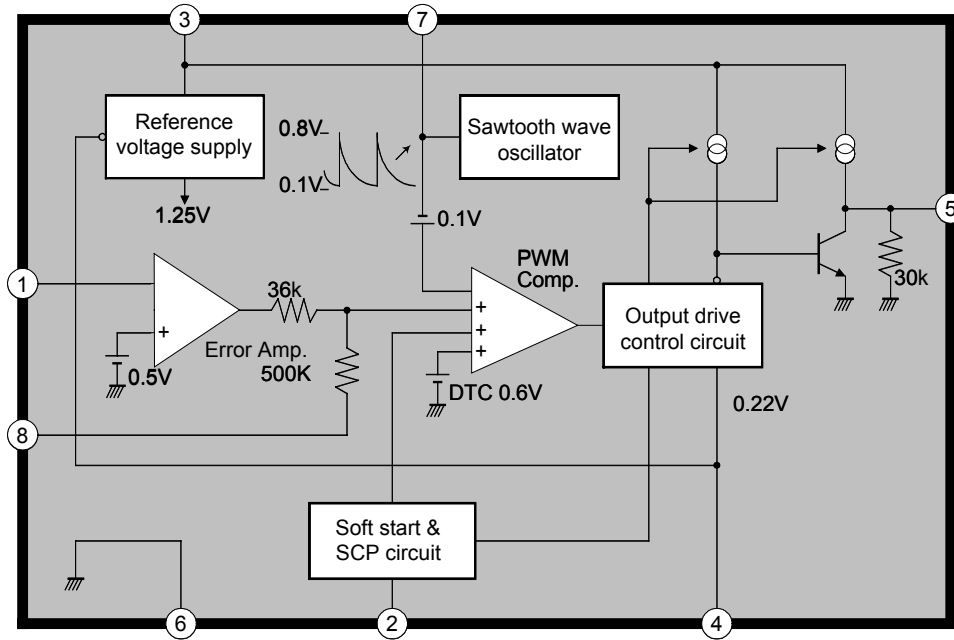

MARK VIEW

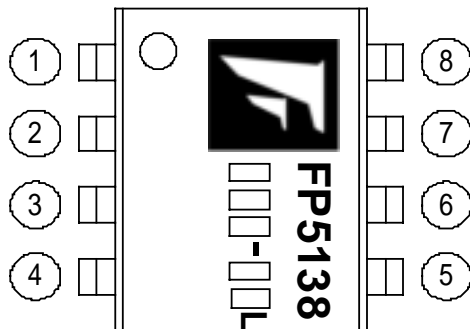

PIN DESCRIPTION

Name	No.	I/O	Description
FB	1	I	Error amplifier inverting input pin
SCP	2	I	Connected a capacitor Soft start and SCP function pin
V _{CC}	3	P	IC power supply
BR/CTL	4	I	Output current setting and control pin
OUT	5	O	Totem-pole output
GND	6	P	IC ground
OSC	7	I	Capacitor and resistor connected for the frequency of oscillation
COMP	8	O	Error amplifier compensation output

ORDER INFORMATION

Part Number	Operating Temperature	Package	Description
FP5138D-LF	-10°C ~ +85°C	SOP8	Tube
FP5138DR-LF	-10°C ~ +85°C	SOP8	Tape & Reel
FP5138W-LF	-10°C ~ +85°C	TSSOP8	Tube
FP5138WR-LF	-10°C ~ +85°C	TSSOP8	Tape & Reel
FP5138T-LF	-10°C ~ +85°C	MSOP8	Tube
FP5138TR-LF	-10°C ~ +85°C	MSOP8	Tape & Reel
FP5138X-LF	-10°C ~ +85°C	SOP8-EXPOSED PAD	Tube
FP5138XR-LF	-10°C ~ +85°C	SOP8-EXPOSED PAD	Tape & Reel

IC DATE CODE DISTINGUISH

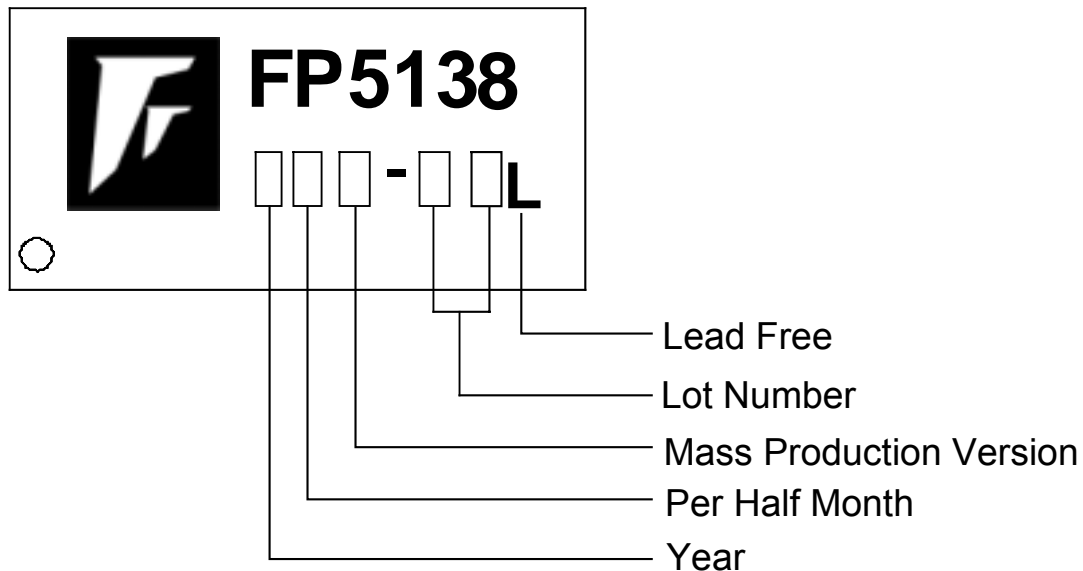

FOR EXAMPLE:

January A (Front Half Month), B (Last Half Month)
 February C, D
 March E, F -----And so on

Lot Number is the last two numbers

For Example:

A3311C62
 ↳ Lot Number

ABSOLUTE MAXIMUM RATINGS

Power supply voltage-----	+15V
Output source current-----	-50mA
Output sink current-----	+50mA
Allowable dissipation	
SOP8 Ta +25 -----	570mW
MSOP8 Ta +25 -----	400mW
TSSOP8 Ta +25 -----	400mW
SOP8-EXPOSED PAD Ta +25 -----	600mW
Operating temperature-----	-10 +85
Storage temperature-----	-55 +125
SOP8 Lead Temperature (soldering, 10 sec) -----	+260
TSSOP8 Lead Temperature (soldering, 10 sec) -----	+260
MSOP8 Lead Temperature (soldering, 10 sec) -----	+260

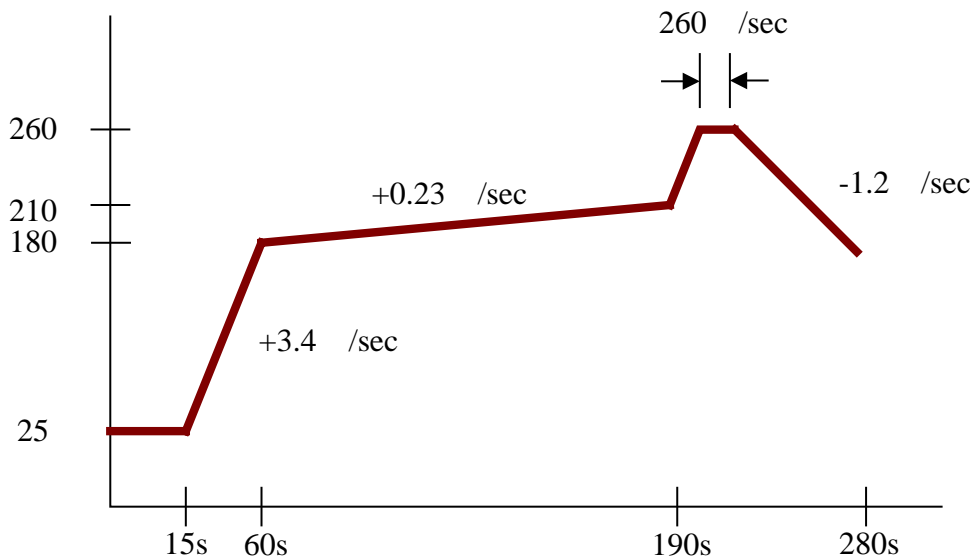

DC ELECTRICAL CHARACTERISTICS (Ta=25 °C, V_{CC}=2V, unless otherwise noted)

Under Voltage Lock-Out section (U.V.L.O.)

PARAMETER	SYMBOL	TEST CONDITIONS	MIN.	TYP.	MAX.	UNIT
Low threshold voltage	V _{LOW}	--	-	-	0.9	V
Upper threshold voltage	V _{UPPER}	--	1.1	1.3	1.5	V

Soft Start section (S.S.)

PARAMETER	SYMBOL	TEST CONDITIONS	MIN.	TYP.	MAX.	UNIT
Input source current	I _{SS}	V _{SCP} = 0V	-1.5	-1.0	-0.7	μA
Soft start threshold voltage	V _{SST}	--	0.8	0.9	1.0	V

Short Circuit Protection section (S.C.P.)

PARAMETER	SYMBOL	TEST CONDITIONS	MIN.	TYP.	MAX.	UNIT
Input source current	I _{SCP}	V _{SCP} = 0V	-1.5	-1.0	-0.7	μA
S.C.P. threshold voltage	V _{SCP}	--	0.7	0.8	0.9	V

Oscillator section

PARAMETER	SYMBOL	TEST CONDITIONS	MIN.	TYP.	MAX.	UNIT
Oscillation frequency	f	R _T =3.0kΩ, C _T =270pF	400	500	600	KHz
Frequency change with voltage	Δf / ΔV	V _{CC} =2V to 15V	-	2	10	%
Frequency change with temperature	Δf / ΔT	Ta = 0 °C to 85 °C	-	5	-	%

Idle Period Adjustment section

PARAMETER	SYMBOL	TEST CONDITIONS	MIN.	TYP.	MAX.	UNIT
Maximum duty cycle	T _{DUTY}	R _T =3.0kΩ, C _T =270pF, V _{FB} =0.8V	75	-	85	%

Total device section

PARAMETER	SYMBOL	TEST CONDITIONS	MIN.	TYP.	MAX.	UNIT
Stand-by current	I _{STANDBY}	Pin4 is open or V _{CC}	-	-	1	μA
Average supply current	I _{AVE}	R _B =390Ω, V _{CC} =0~20V	-	5.0	10	mA

DC ELECTRICAL CHARACTERISTICS (Cont.)

Error Amplifier section

PARAMETER		SYMBOL	TEST CONDITIONS	MIN.	TYP.	MAX.	UNIT
Input threshold voltage		V_{FB}	$V_{COMP}=450mV$	495	500	505	mV
V_T change with voltage		$\Delta V_{FB} / \Delta V$	$V_{CC}=2V$ to 15V	-	5	20	mV
V_T change with temperature		$\Delta V_{FB} / \Delta T$	$T_a = -10$ to 85	-	1	-	%
Input bias current		I_B	--	-1.0	-0.2	1.0	μA
Voltage Gain		A_v	--	-	100	-	V/V
Frequency bandwidth		BW	$A_v=0$ dB	-	6	-	MHz
Output voltage Swing	Positive	V_{POS}	--	0.78	0.87	-	V
	Negative	V_{NEG}	--	-	0.05	0.2	
Output source current		I_{SOURCE}	$V_{COMP}=450mV$	-	-40	-24	μA
Output sink current		I_{SINK}		24	40	-	μA

Output section

PARAMETER		SYMBOL	TEST CONDITIONS	MIN.	TYP.	MAX.	UNIT
Output high voltage		V_{OH1}	$R_B=390\Omega$, $I_O=-15mA$	1.0	1.2	-	V
Output high voltage		V_{OH2}	$R_B=750\Omega$, $I_O=-10mA$, $V_{CC}=1.8V$	0.8	1.0	-	V
Output saturation voltage		V_{OL1}	$R_B=390\Omega$, $I_O=15mA$	-	0.1	0.2	V
Output saturation voltage		V_{OL2}	$R_B=750\Omega$, $I_O=10mA$, $V_{CC}=1.8V$	-	0.1	0.2	V
Output source current		$I_{OSOURCE}$	$R_B=390\Omega$, $V_O=0.9V$	-	-40	-20	mA
Output sink current		I_{OSINK}	$R_B=390\Omega$, $V_O=0.3V$	30	40	-	mA
Internal pull-down resistor		R_O	--	20	30	40	k Ω

Output Current Setting / Control section

PARAMETER		SYMBOL	TEST CONDITIONS	MIN.	TYP.	MAX.	UNIT
Pin voltage		V_{BR}	$R_B=390\Omega$	0.15	0.22	0.3	V
Input off condition		I_{OFF}	--	-20	-	0	μA
Input on condition		I_{ON}	--	-	-	-45	μA
Pin current range		I_{BR}	--	-1.8	-	-0.1	mA

TYPICAL CHARACTERISTICS

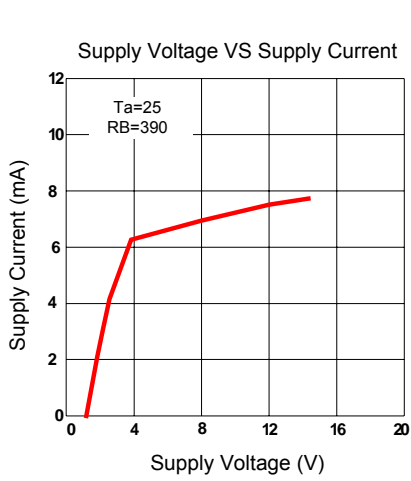

Figure 1

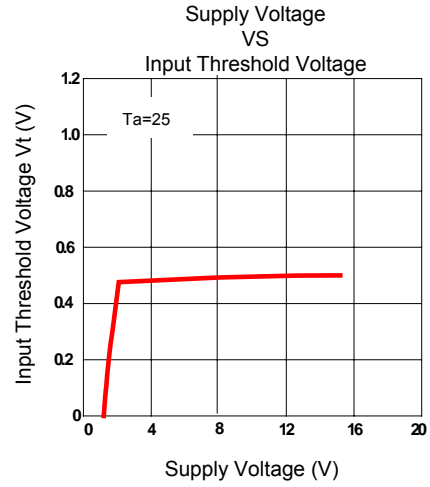

Figure 2

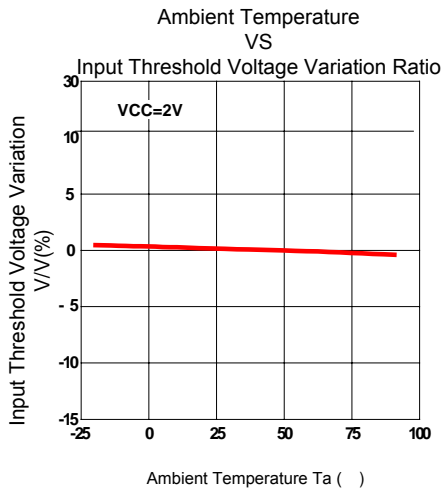

Figure 3

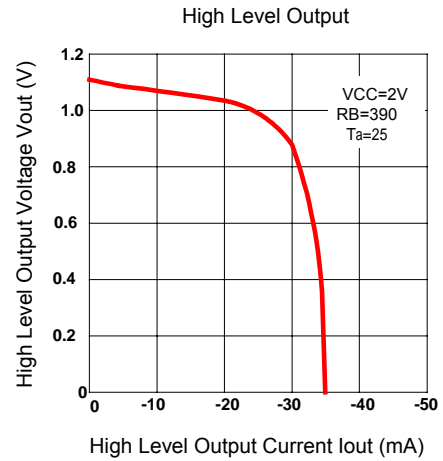

Figure 4

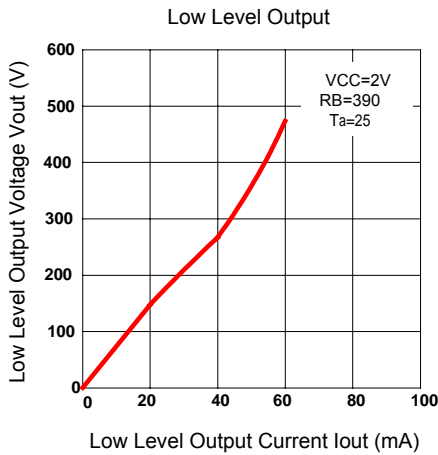

Figure 5

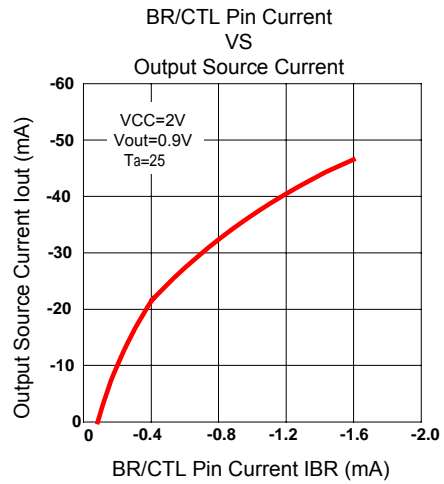

Figure 6

TYPICAL CHARACTERISTICS (Cont.)

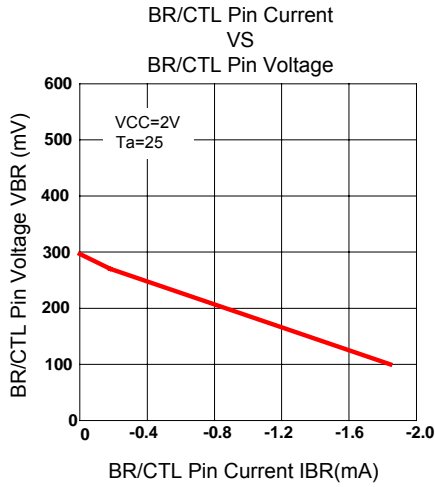

Figure 7

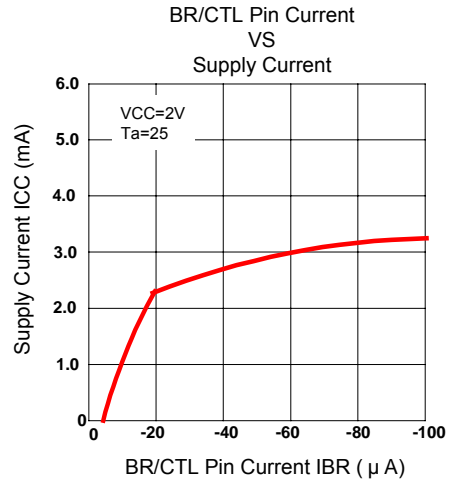

Figure 8

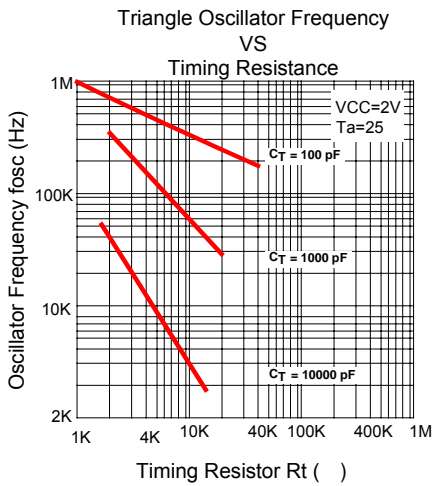

Figure 9

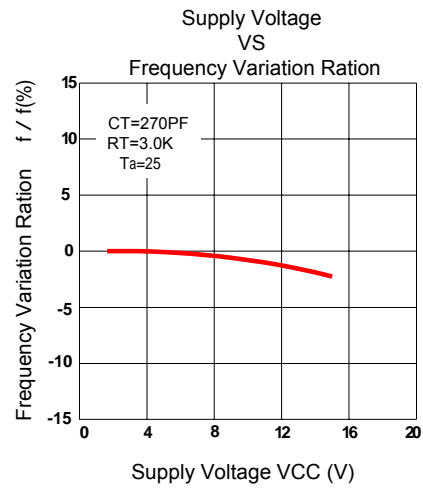

Figure 10

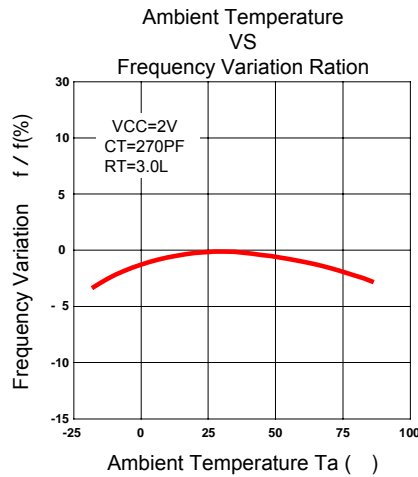
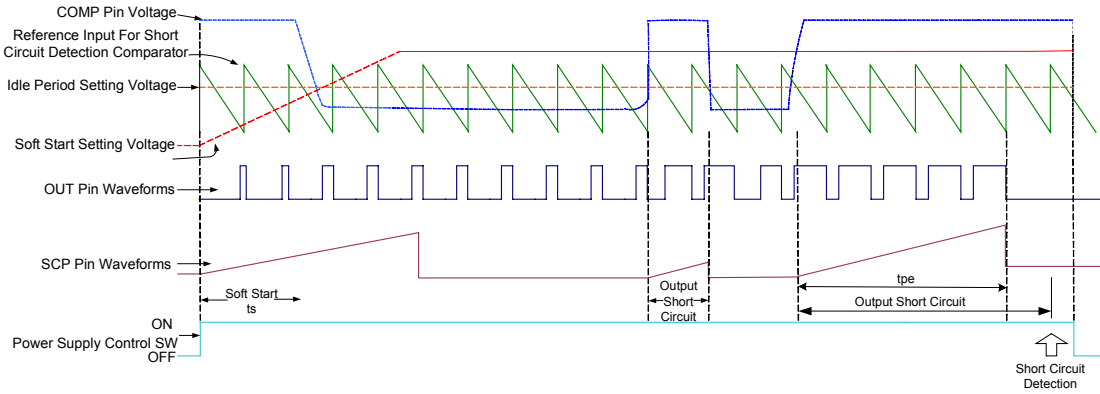

Figure 11

TIMING WAVEFORM



FP5138 Timing Diagram

DETAILED DESCRIPTION

Voltage reference

A 1.25V regulator operating from VCC is used to power the internal circuitry of the **FP5138**. An internal resistive divider provides 0.5V reference for the error amplifier, Soft-start (typ. 0.9V) and SCP (typ. 0.8V) circuits.

Error amplifier

The error amplifier compares a sample of the dc-dc converter output voltage to the 0.5V reference and generates an error signal for the PWM comparator. Output voltage of dc-dc converter is setting with the resistor divider using the following expression (see fig12):

$$V_{out} = \left(1 + \frac{R1}{R2}\right) * 0.5$$

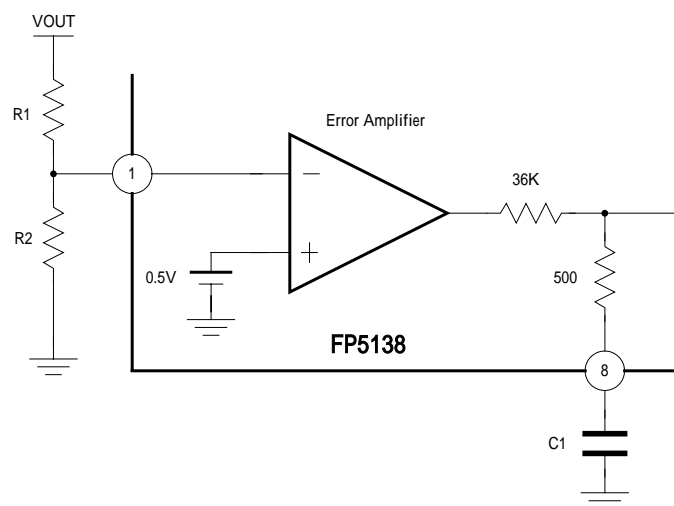

Figure 12. Error Amplifier with Feedback resistance divider

Oscillator

The oscillator frequency can be set between 20KHz and 500KHz by connecting a resistor and a capacitor at OSC pin of **FP5138** to ground. The oscillator frequency can be determined by using the graph shown in Figure 9.

The oscillator output is a sawtooth wave with a minimum value of approximately 0.1V and a maximum value of approximately 0.8V. The PWM comparator compares the oscillator voltage with error amplifier output voltage; internal DTC voltage (typ. 0.6V) and soft start setting voltage. When the sawtooth wave voltage is low than above three-output voltage, the output of **FP5138** is high (Turn on NPN transistor or NMOS).

Under voltage lockout (UVLO)

The under voltage lockout circuits turn the output off and whenever the supply voltage drops too low (approximately 0.9V at 25) for proper operation. A hysteresis voltage of 200mV eliminates false triggering on noise and chattering.

Soft Start/ Short-circuit protection (S.S. / S.C.P.)

The soft start is functional after power on, and the interval of soft start time is determined by a capacitor connected to SCP pin (pin 2). When soft start function finished, the internal soft start voltage is setting high, but external SCP pin is setting low in order to change to short circuit detection / protection function.

The time of soft start is following expression:

$$T_{ss} = 0.35 * C[\mu F]$$

The short circuit protection is functional due to a heavy loading drop and output of error amplifier (COMP pin) is maintain a V_{POS} (typ. 0.9V), the capacitor is charged until SCP threshold voltage (typ. 0.8V), then **FP5138** output is disable (internal pull-low) and the capacitor is discharged to low.

The time of short circuit protection is following expression:

$$T_{scp} = 0.8 * C[\mu F]$$

Output transistor

The **FP5138** has a totem-pole transistor with a 40mA source/sink current rating to drive an external NPN transistor or NMOS directly. The driving current capability depends on a resistor R that is connected to BR/CTL pin (Pin4) of **FP5138**. (see fig. 14)

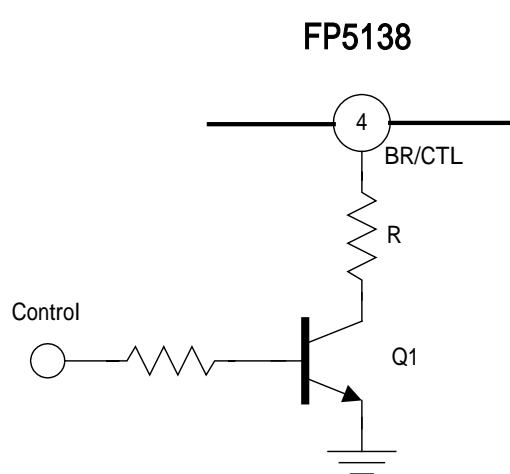

Figure 13. Output transistor driving control circuit

BR/CTL pin can also use to control the output of **FP5138** for disable or enable function of system.

Control Pin	Q1	BR/CTL Pin	Output Transistor Function	Mode
Low	Off	Open	Disable	Stand-by
High	On	Bias Current	Enable	Operation

APPLICATION NOTE (1)

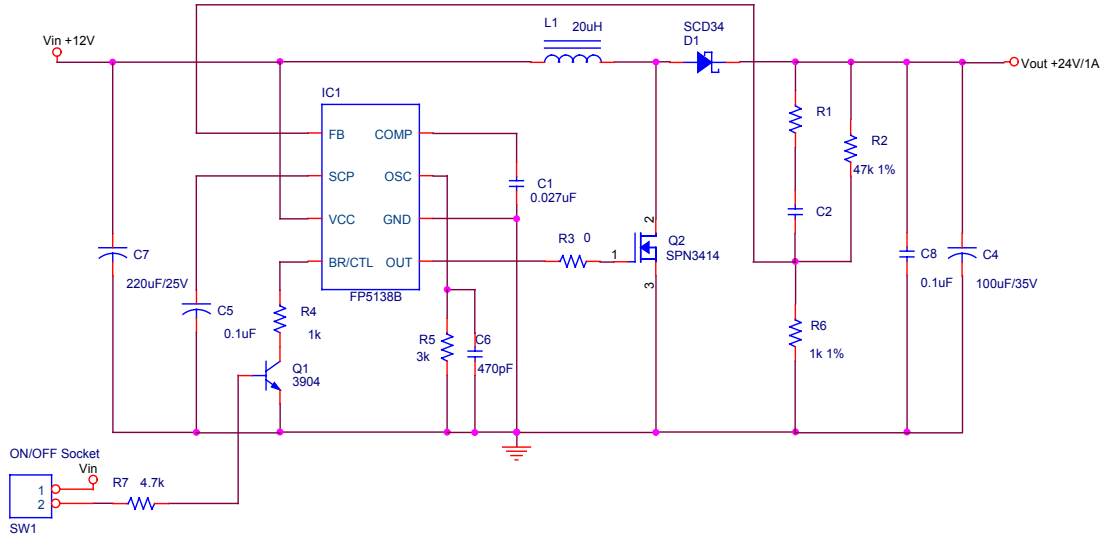

Figure 14. DC12V to DC24V Boost Regulator

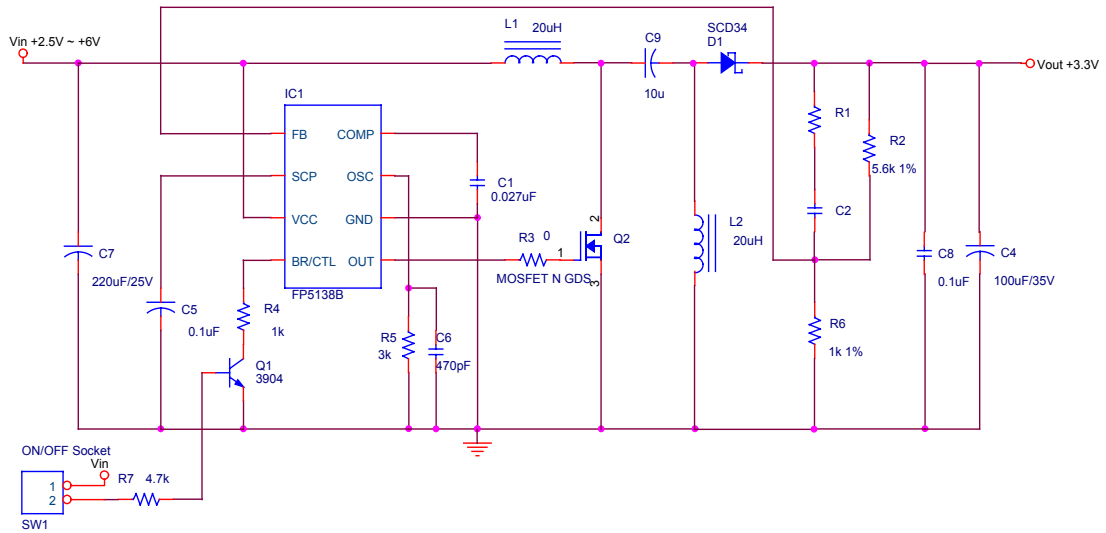

Figure 15. DC2.5V~DC6V to DC3.3V SEPIC Regulator

APPLICATION NOTE (2)

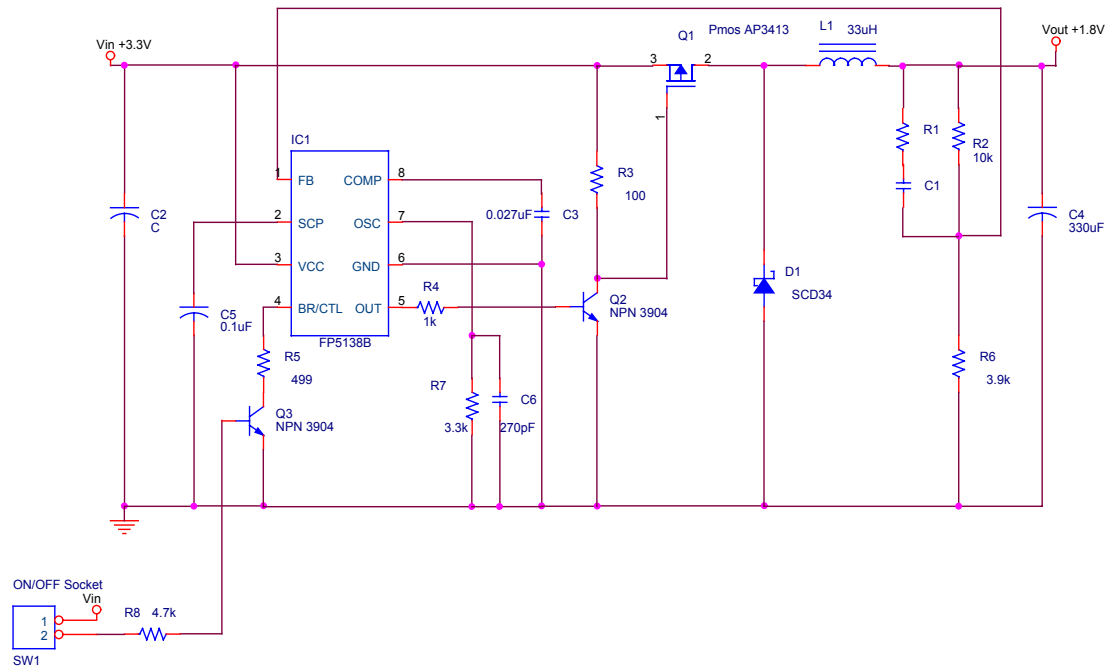

Figure 16. DC3.3V to DC1.8V Buck Regulator

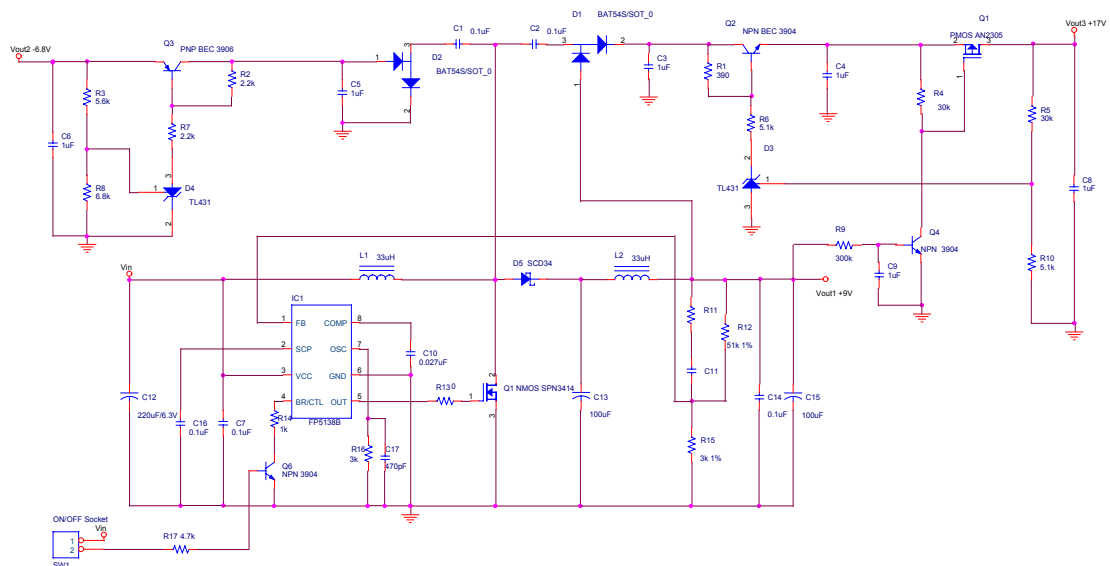

Figure 17. Charge Pump DC-DC Converter Circuits

APPLICATION NOTE (3)

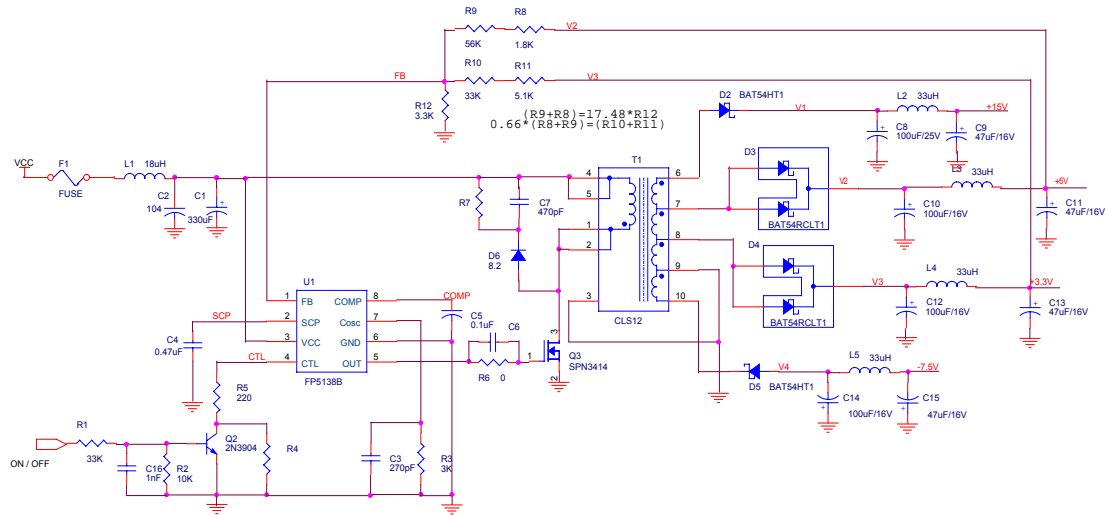
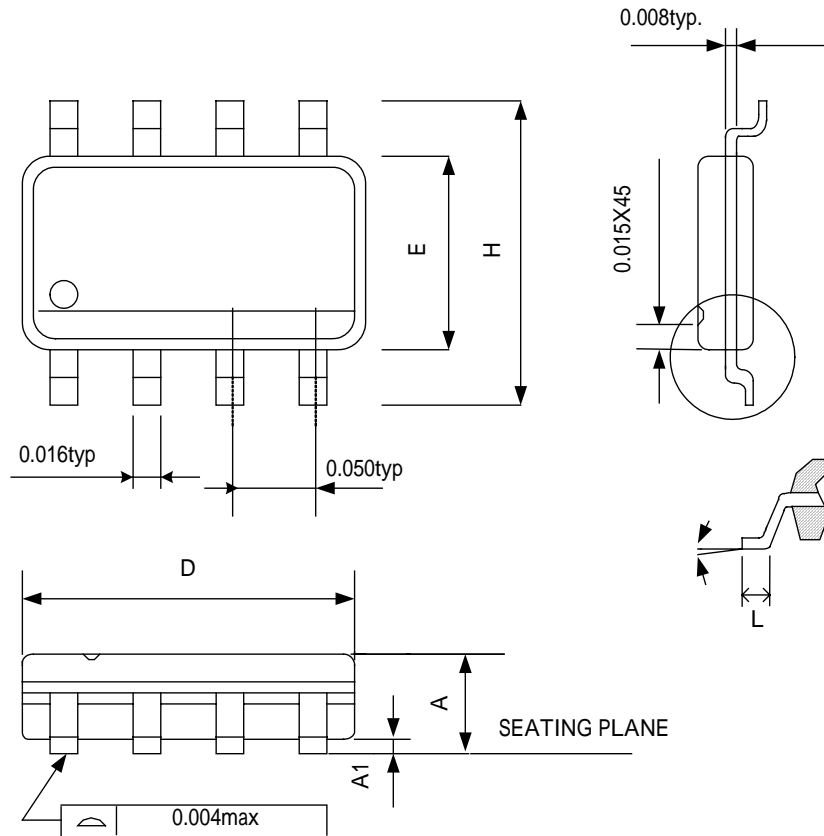

Figure 18. Flyback Multi-output DC-DC Converter Circuits

PACKAGE OUTLINE SOP8



SYMBOLS	MIN	MAX
A	1.346	1.752
A1	0.101	0.254
D	4.800	4.978
E	3.810	3.987
H	5.791	6.197
L	0.406	1.270
°	0	8

UNIT:MM

NOTE:

1. JEDEC OUTLINE:MS-012 AA
2. DIMENSIONS "D" DOES NOT INCLUDE MOLD FLASH,PROTRUSIONS OR GATE BURRS.MOLD FLASH,PROTRUSIONS AND GATE BURRS SHALL NOT EXCEED .15mm (.06in) PER SIDE
3. DIMENSIONS "E" DOES NOT INCLUDE INTER-LEAD FLASH,OR PROTRUSIONS. INTER-LEAD FLASH AND PROTRUSIONS SHALL NOT EXCEED .25mm (.0.10in) PER SIDE.

MSOP8

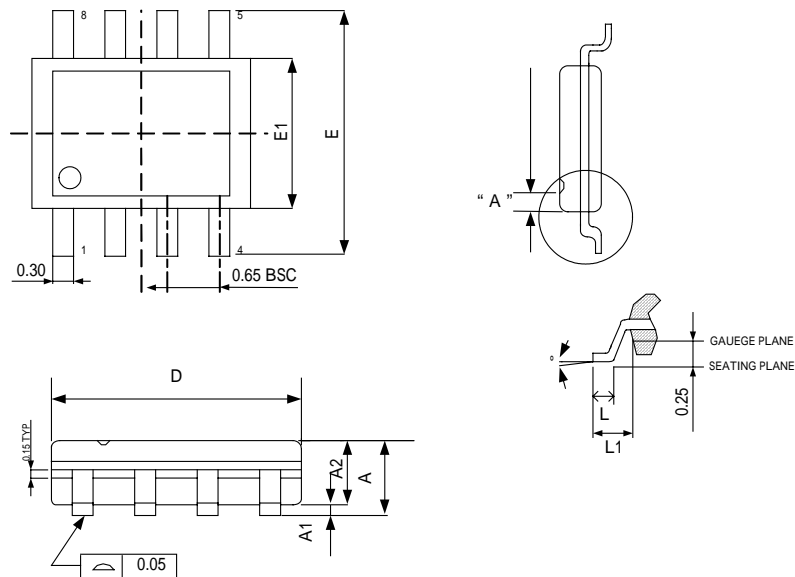

SYMBOLS	MIN	MAX
A	-	1.10
A1	0.00	0.15
A2	0.75	0.95
D	3.00 BSC	
E	4.90 BSC	
E1	3.00 BSC	
L	0.40	0.80
L1	0.95 REF	
°	0	8

UNIT:MM

NOTE:

- 1.JEDEC OUTLINE:MO-187 AA
- 2.DIMENSIONS "D" DOES NOT INCLUDE MOLD FLASH,PROTRUSIONS OR GATE BURRS.MOLD FLASH,PROTRUSIONS AND GATE BURRS SHALL NOT EXCEED 0.15 PER SIDE
- 3.DIMENSIONS "E1" DOES NOT INCLUDE INTERLEAD FLASH,OR PROTRUSIONS. INTERLEAD FLASH OR PROTRUSIONS SHALL NOT EXCEED 0.25 PER SIDE.
- 4.DIMENSIONS "0.22" DOES NOT INCLUDE DAMBAR PROTRUSIONS.ALLOWABLE DAMBAR PROTRUSIONS SHALL BE 0.08 MM TOTAL IN EXCESS OF THE '0.22' DIMENSION AT MAXIMUM MATERIAL CONDITION.DAMBAR CANNOT BE LOCATED ON THE LOWER RADIUS OF THE FOOT.MINIMIM SPAC BETWEEN PROTRUSION AND ADJACENT LEAD IS 0.07MM.
- 5.DIMENSIONS "D" AND 'E1' TO BE DETERMINED AT DATUM PLANE H

TSSOP8

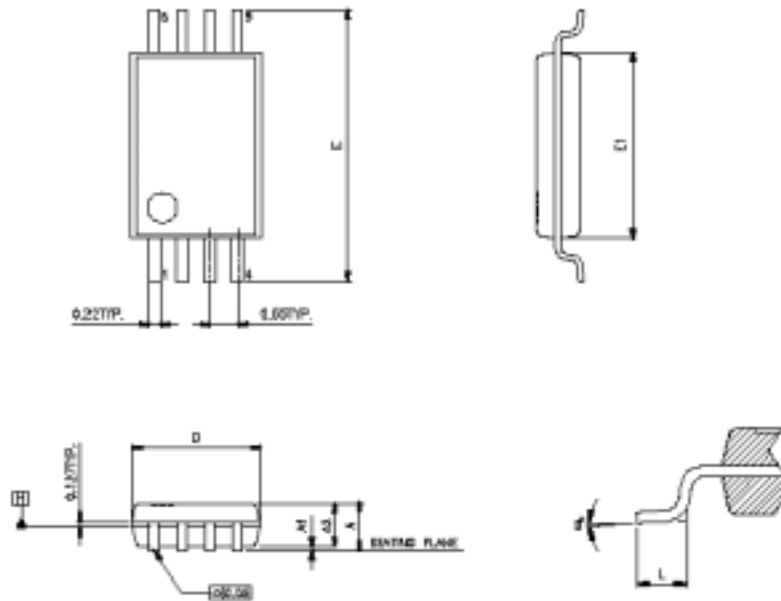

SYMBOLS	MIN	NOR	MAX
A	-	-	1.20
A1	0.05	-	0.15
A2	0.96	1.01	1.06
D	2.90	3.00	3.10
E	6.40 BSC		
E1	4.30	4.40	4.50
L	0.45	0.60	0.75
°	0	-	8

UNIT:MM

NOTE:

- 1.JEDEC OUTLINE:MO-187 AA
- 2.DIMENSIONS "D" DOES NOT INCLUDE MOLD FLASH,PROTRUSIONS OR GATE BURRS.MOLD FLASH,PROTRUSIONS OR GATE BURRS SHALL NOT EXCEED 0.15 PER SIDE
- 3.DIMENSIONS "E1" DOES NOT INCLUDE INTERLEAD FLASH,OR PROTRUSIONS. INTERLEAD FLASH OR PROTRUSIONS SHALL NOT EXCEED 0.25 PER SIDE.
- 4.DIMENSIONS "0.22" DOES NOT INCLUDE DAMBAR PROTRUSIONS.ALLOWABLE DAMBAR PROTRUSIONS SHALL BE 0.08 MM TOTAL IN EXCESS OF THE '0.22' DIMENSION AT MAXIMUM MATERIAL CONDITION.DAMBAR CANNOT BE LOCATED ON THE LOWER RADIUS OF THE FOOT.MINIMIM SPAC BETWEEN PROTRUSION AND ADJACENT LEAD IS 0.07MM.
- 5.DIMENSIONS "D" AND 'E1' TO BE DETERMINED AT DATUM PLANE H

SOP8-EXPOSED PAD

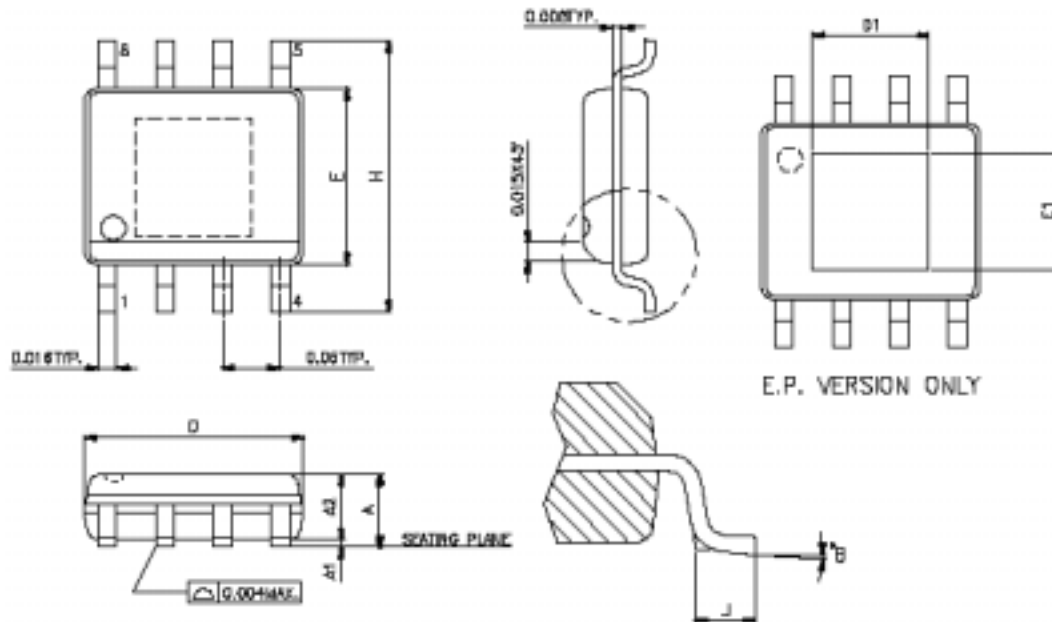

SYMBOLS	MIN	MAX
A	1.346	1.752
A1	0.101	0.254
D	4.800	4.978
E	3.810	3.987
H	5.791	6.197
L	0.406	1.270
°	0	8

UNIT:MM

THERMALLY ENHANCED DIMENSIONS

PAD SIZE	E1	D1
A	2.057 REF	2.057 REF
A1	2.184 REF	2.971 REF

UNIT:MM

NOTE:

- 1.JEDEC OUTLINE:N/A
- 2.DIMENSIONS "D" DOES NOT INCLUDE MOLD FLASH,PROTRUSIONS OR GATE BURRS.MOLD FLASH,PROTRUSIONS AND GATE BURRS SHALL NOT EXCEED .15mm (.0.06in) PER SIDE
- 3.DIMENSIONS "E" DOES NOT INCLUDE INTER-LEAD FLASH,OR PROTRUSIONS. INTER-LEAD FLASH AND PROTRUSIONS SHALL NOT EXCEED .25mm (.0.10in) PER SIDE.

PACKING SPECIFICATIONS

BOX DIMENSION

TUBE INSIDE BOX AND CARTON

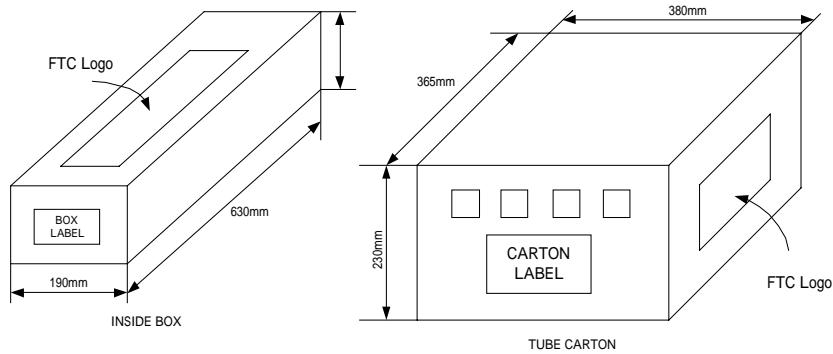

TAPE AND REEL INSIDE BOX AND CARTON

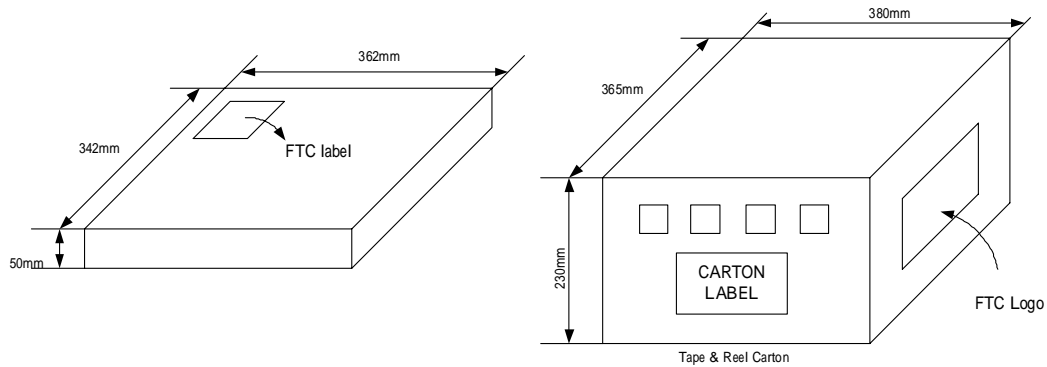

PACKING QUANTITY SPECIFICATIONS

SOP 8	MSOP8	TSSOP8	SOP8-EXPOSED PAD	SOP 8	MSOP8	TSSOP8	SOP8-EXPOSED PAD
100	80	160	100 EA/TUBE	2500 EA / REEL			
100 TUBES / INSIDE BOX				4 INSIDE BOXES / CARTON			
4 INSIDE BOXES / CARTON							

LABEL SPECIFICATIONS

Tapping & Reel

Feeling Technology Corp. Product FP5138DR-LF Lot No A3311C62-L D/C 4Xx-XXL Q'ty	<div style="border: 1px solid black; padding: 2px; display: inline-block;"> 無鉛 Lead Free </div>
---	--

CARTON

Feeling Technology Corp.	
Product Type: FP5138DR-LF	
Lot No: A3311C62-L	
Date Code: 4Xx-XXL	
Package Type: SOP-8L	
Marking Type: Laser	無鉛 Lead Free
Total Q'ty: 10,000	

SOP8

CARRIER TAPE DIMENSIONS

APPLICATION	W	P	E	F	D	D ₁
SOP8	12.0 ^{+0.3} _{-0.1}	8.0±0.1	1.75±0.1	5.5±0.1	1.55±0.1	1.5 ^{+0.25}

APPLICATION	P ₀	P ₁	A _D	B ₀	K ₀	t
SOP8	4.0±0.1	2.0±0.1	6.4±0.1	5.20±0.1	2.1±0.10	0.30±0.013

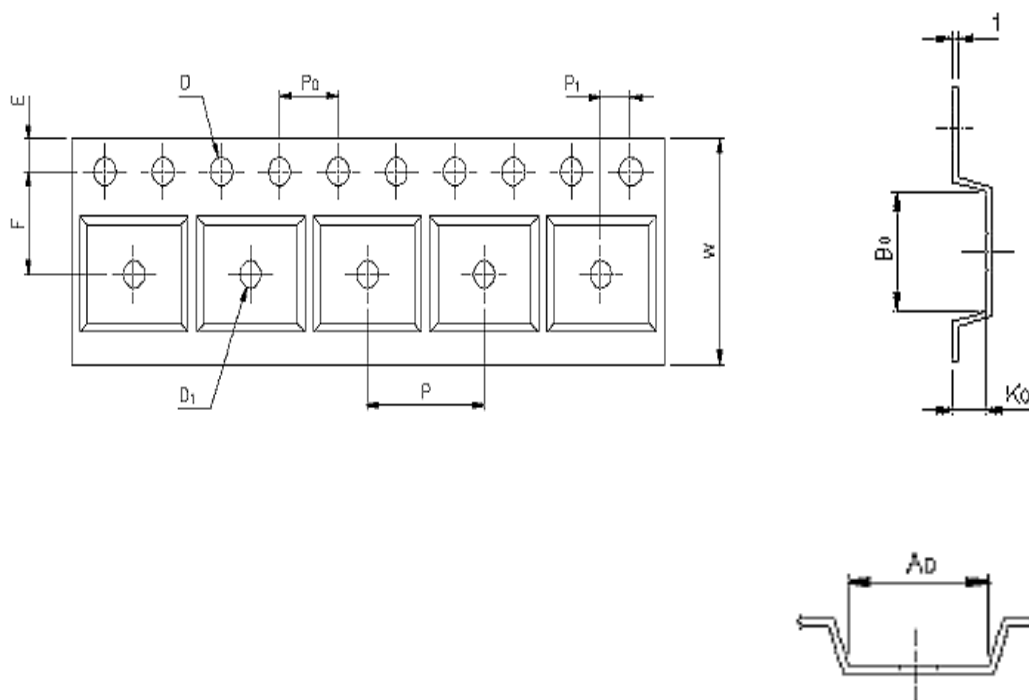

REEL DIMENSIONS

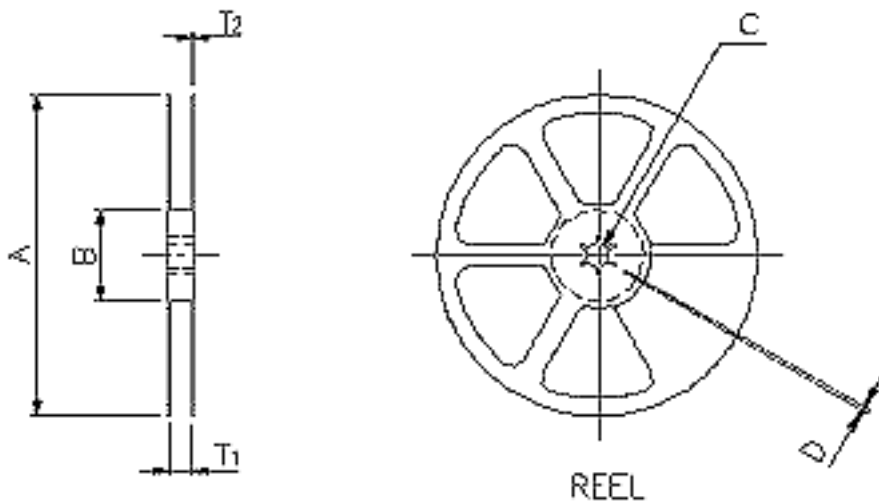

APPLICATION	MATERIAL	A	B	C	D	T ₁	T ₂
SOP8	PLASTIC REEL (WHILE)	330±0.1	62±1.5	12.75+0.15	2+0.6	12.4+0.2	2.0+0.2

MSOP8

CARRIER TAPE DIMENSIONS

APPLICATION	W	P	E	F	D	D ₁
MSOP8	12.0±3	8.0	1.75±1.0	5.5±0.5	1.5 ^{+0.1}	1.50

APPLICATION	P ₀	P ₁	A _D	B ₀	K ₀	t
MSOP8	4.0±0.1	2.0±0.5	4.20	3.30	1.20	0.30±0.5

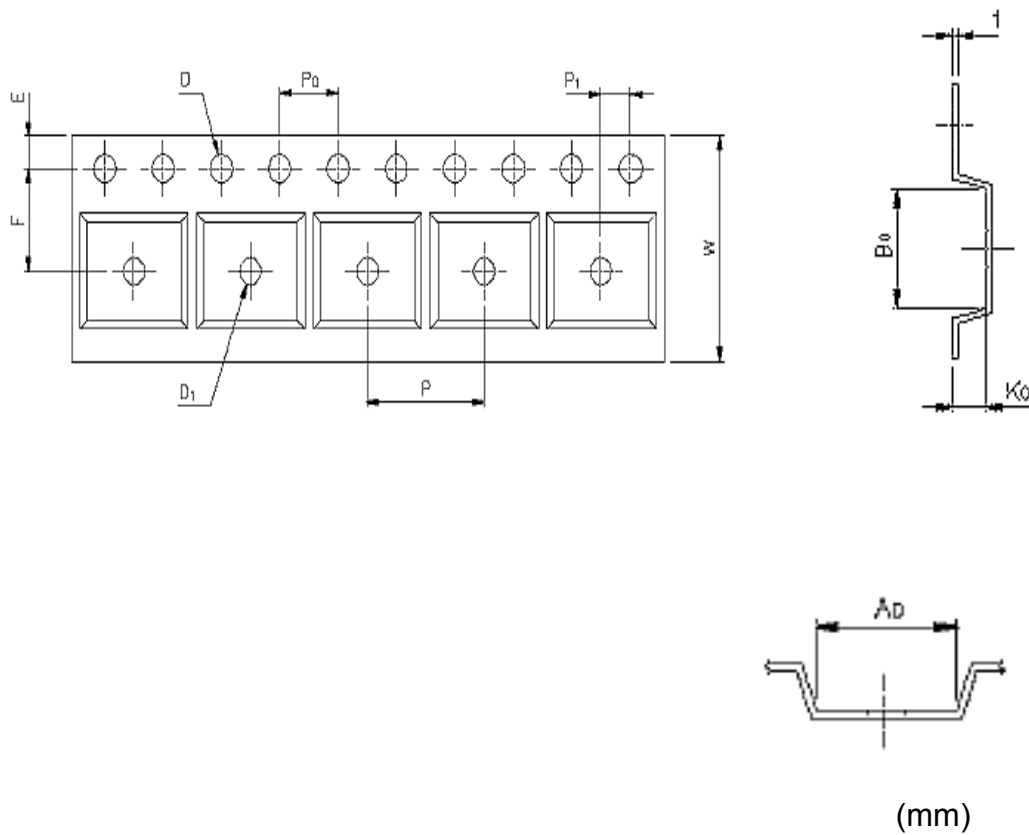

REEL DIMENSIONS

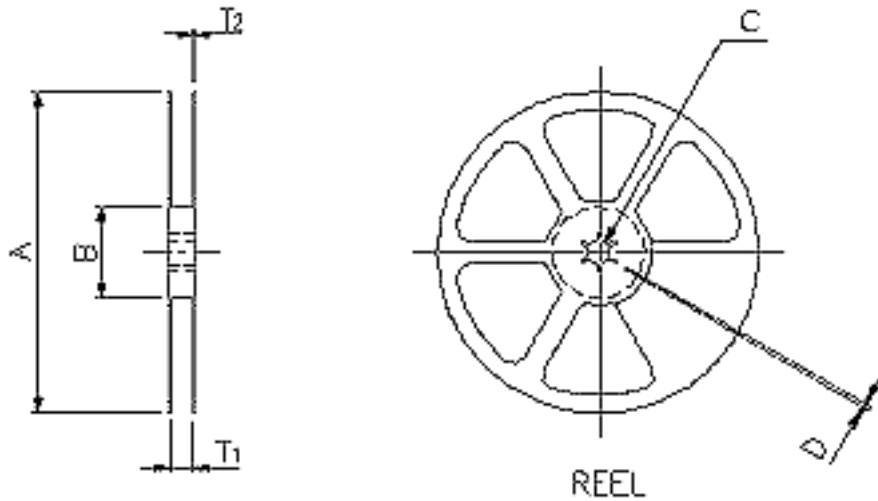

APPLICATION	MATERIAL	A	B	C	D	T ₁	T ₂
MSOP8	PLASTIC REEL (WHITE)	330±1	62±1.5	12.75 ^{+0.15}	2±0.15	12.4 ^{+0.2}	16.8 ^{-0.4}

TSSOP8
CARRIER TAPE DIMENSIONS

APPLICATION	W	P	E	F	D	D ₁
TSSOP8	12.0±0.3	8.00	1.75±1.0	5.5±0.05	1.5 ^{+0.1}	1.50

APPLICATION	P ₀	P ₁	A _D	B ₀	K ₀	t
TSSOP8	4.00	2.00±0.05	4.20	3.40	1.30	0.30±0.5

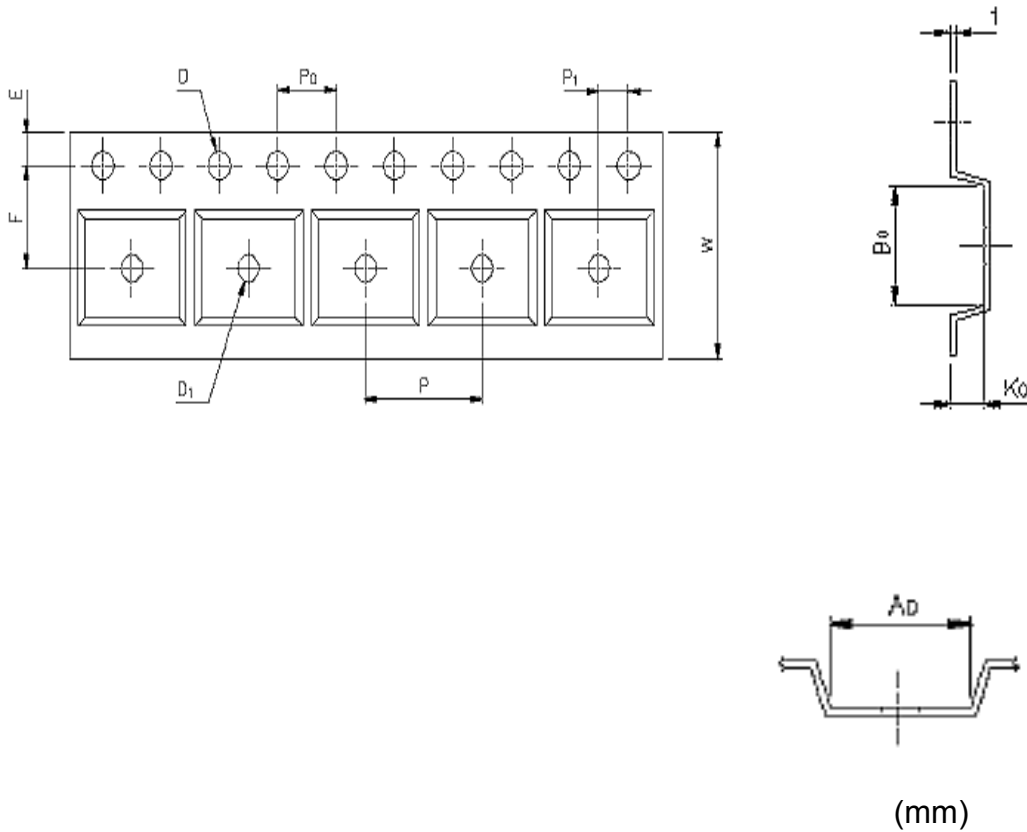

REEL DIMENSIONS

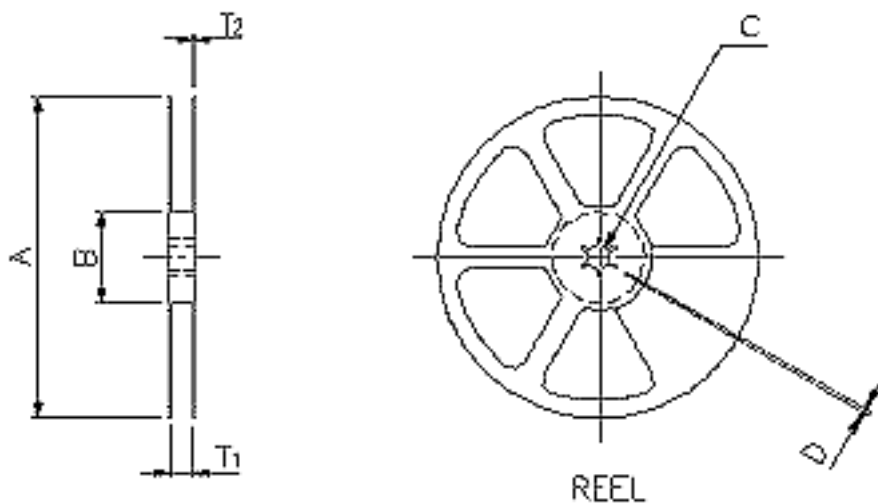

APPLICATION	MATERIAL	A	B	C	D	T ₁
TSSOP8	PLASTIC REEL (WHITE)	330	100	13.0 ^{+0.5}	2±0.5	12.5

SOP8-EXPOSED PAD CARRIER TAPE DIMENSIONS

APPLICATION	W	P	E	F	D	D ₁
SOP8	12.0 ^{+0.3} _{-0.1}	8.0±0.1	1.75±0.1	5.5±0.1	1.55±0.1	1.5 ^{+0.25}

APPLICATION	P ₀	P ₁	A _D	B ₀	K ₀	t
SOP8	4.0±0.1	2.0±0.1	6.4±0.1	5.20±0.1	2.1±0.10	0.30±0.013

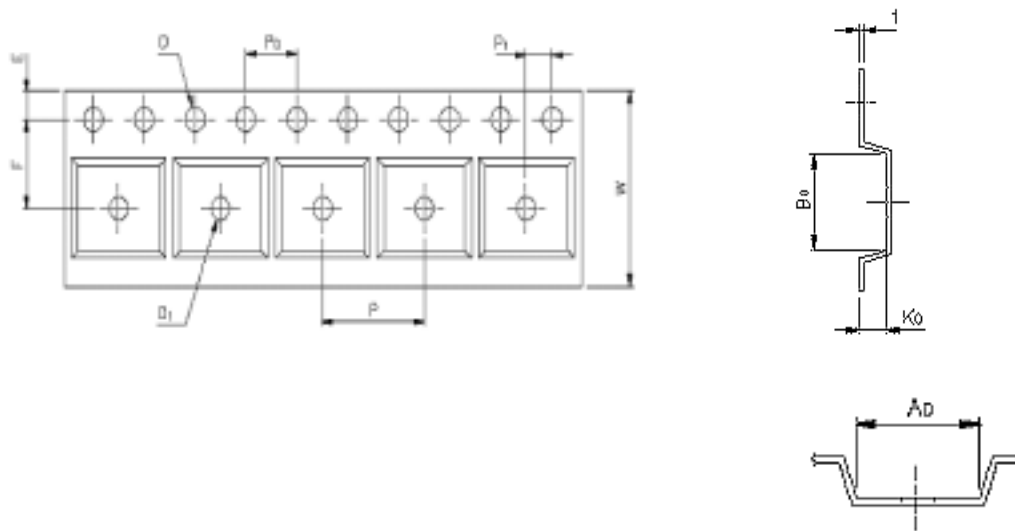

REEL DIMENSIONS

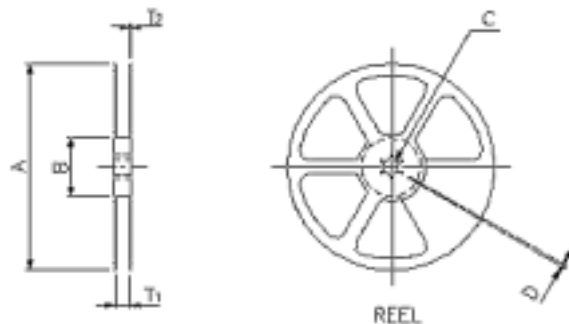

APPLICATION	MATERIAL	A	B	C	D	T ₁	T ₂
SOP8	PLASTIC REEL (WHILE)	330±0.1	62±1.5	12.75±0.15	2±0.6	12.4±0.2	2.0±0.2