



Introduction

EIC is a major international manufacturer and distributor of power discrete semiconductors. With over 10,000 parts and more than 50 package types, EIC offers one of the most comprehensive diode portfolios in the industry.

EIC provides its customers with superb service and technical support, as well as high quality products at competitive prices. The company's processes and procedures from design to after sales service are fully ISO 9001, ISO 14001, and ISO/TS16949 certified and all products are RoHS compliant. With sales offices worldwide, and a reliable logistics process, EIC is able to offer customers quick responses to both technical enquiries and product delivery.

The EIC Engineering team is focused on developing superior discrete products to satisfy the variety of requirements of new customer systems. The company also offers an extensive capability for research and development of special purpose devices, to satisfy unique customer applications. These are achieved with close attention to cost reduction and fast time to market.

EIC had expanded a wafer fabrication plant in Bangkok. Together with the existing assembly facility, EIC will be able to offer customers full end to end manufacturing and product development support. This will allow the company to have even better control over product quality, cost and flexibility of supply. Faster development of new technologies and products will also result from this centralised manufacturing process.

Electronics Industry Public Company Limited, established since 1984, is listed on the Stock Exchange of Thailand in the Electronics Component section under Technology Group, using 'EIC' as its trading abbreviation.

To help you to choose the best components for your application, this product selection guide contains numerical, product and packaging information; plus contact addresses for additional support.



Symbols

C_J	Junction Capacitance
I_F	DC Forward Current
$I_{(AV)}$	Average Forward Rectifier Current
I_{FSM}	Peak Forward Surge Current
I_R	Reverse Current
I_{RSM}	Maximum Non-Repetitive Peak Current
I_O	Mean Forward Current
I_T	On-State Test Current
I_{PPM}	Maximum peak impulse Current
I^2t	Rating for Fusing
P_D	Steady State Power Dissipation
P_{PK}	Peak Power Dissipation
$R_{\Theta JA}$	Thermal Resistance (Junction to Ambient)
$R_{\Theta JC}$	Thermal Resistance (Junction to Case)
$R_{\Theta JL}$	Thermal Resistance (Junction to Lead)
T_a	Ambient Temperature
T_c	Case Temperature
T_J	Junction Temperature
T_L	Lead Temperature
T_{tp}	Tie-Point Temperature
T_{rr}	Reverse Recovery Time
$V_{(BR)}$	Reverse Breakdown Voltage
V_F	Forward Voltage
V_R	Reverse Voltage
V_{RM}	Maximum Recurrent Peak Reverse Voltage
V_{RMS}	RMS Input Voltage
V_{RSM}	Maximum Reverse Voltage (Clamping Voltage) at I_{RSM}
V_{RRM}	Repetitive Peak Reverse Voltage
V_{RWM}	Working Peak Reverse Voltage (Stand-off Voltage)
V_Z	Zener Voltage
Z_{ZK}	Zener Impedance at I_{ZK}
Z_{ZT}	Zener Impedance at I_{ZT}



Contents

Numerical Index	4
Silicon Rectifier Diodes.....	14
Glass Passivated Rectifier Diodes.....	22
High Speed Switching Diodes.....	24
High Voltage Rectifier Diodes.....	28
High Voltage Fast Recovery Rectifier Diodes.....	30
Cell Rectifier Diodes.....	31
Automotive Rectifier Diodes.....	32
Avalanche Rectifier Diodes.....	33
Avalanche Fast Recovery Rectifier Diodes.....	34
Fast Recovery Rectifier Diodes.....	37
Fast Recovery Glass Passivated Rectifier Diodes.....	46
High Efficient Rectifier Diodes.....	48
Super Fast Rectifier Diodes.....	50
Super Fast Glass Passivated Rectifier Diodes	56
Schottky Barrier Rectifier Diodes	57
Zener Diodes.....	69
Transient Voltage Suppressor Diodes.....	138
Low Capacitance Transient Voltage Suppressor Diodes.....	174
Ultra Low Capacitance Transient Voltage Suppressor Diodes.....	181
Automotive Transient Suppressor Diodes.....	183
Transient Voltage Suppressor Diodes for ESD Protection	185
Transient Voltage Suppressor Array	186
Glass Passivated Bridge Rectifiers.....	187
Silicon Bridge Rectifiers.....	188
Mini Bridge Rectifiers.....	198
Ultra Fast Recovery Mini Bridge Rectifiers.....	200
Fast Recovery Mini Bridge Rectifiers.....	200
Avalanche Glass Passivated Bridge Rectifiers.....	201
Avalanche Bridge Rectifiers.....	202
Fast Recovery Glass Passivated Bridge Rectifiers.....	205
Fast Recovery Bridge Rectifiers.....	206
Bi-directional Trigger - DIACS.....	209
Thyristor - SIDAC.....	209
Packaging Information	210
Package Outlines.....	218
EIC Worldwide Sales Offices and Representatives.....	229



Numerical Index

Type No.	Page	Type No.	Page
05NU41 to 05NU42	38	1N5221 to 1N5267	89
1.5KE Series	156-157	1N5221B to 1N5267B	89
10A01 to 10A07	21	1N5333A to 1N5388A	136
10ELS1 to 10ELS6	39	1N5333B to 1N5388B	136
10MQ040N	58	1N5391 to 1N5399	18
10MQ100N	58	1N5391G to 1N5399G	23
11DF1 to 11DF4	50	1N5400 to 1N5408	20
11DQ03 to 11DQ10	58	1N5400G to 1N5408G	23
11E1 to 11E6	14	1N5415 to 1N5420	44
11ES1 to 11ES2	14	1N5711	66
15DF4 to 15DF8	41	1N5802 to 1N5806	56
15KP Series	170-171	1N5802US to 1N5806US	56
1A1 to 1A7	14	1N5807 to 1N5811	53
1B4B1	188	1N5807US to 1N5811US	53
1F1 to 1F7	37	1N5817 to 1N5819	57
1G1 to 1G7	22	1N5817WB to 1N5819WB	67
1G4B1	188	1N5820 to 1N5822	60
1H1G to 1H8G	48	1N5820S to 1N5822S	60
1J4B1	188	1N5913A to 1N5956A	130
1N4001 to 1N4007	14	1N5913B to 1N5956B	130
1N4001G to 1N4007G	22	1N6263	66
1N4003ST	14	1N6267 to 1N6303	154-155
1N4148 to 1N4154	24	1N6267A to 1N6303A	154-155
1N4148S	24	1N6267C to 1N6303C	154-155
1N4148W	26	1N6267CA to 1N6303CA	154-155
1N4148WS	26	1N746A to 1N759A	90
1N4148WT	26	1N914,A,B	24
1N4447 to 1N4454	24	1N957B to 1N984B	91
1N4531 to 1N4532	24	1R5JH45	42
1N4728 to 1N4764	112	1R5JU41	42
1N4728A to 1N4764A	112	1S1585 to 1S1588	24
1N4728AG to 1N4764AG	114	1S1885 to 1S1888	16
1N4728C to 1N4764C	112	1S20 to 1SB0	57
1N4728G to 1N4764G	114	1S2076A	24
1N4933 to 1N4937	40	1SMA4728A to 1SMA4764A	115
1N4933G to 1N4937G	46	1SMA5913A to 1SMA5957A	127



Numerical Index

Type No.	Page	Type No.	Page
1SMA5913B to 1SMA5957B	127	3TH41	30
1SMB5913A to 1SMB5956A	131	5KP Series	164-165
1SMB5913B to 1SMB5956B	131	6A05 to 6A10	20
1SR124-100 to 1SR124-400	39	A2W005G to A2W10G	201
1SR139-100 to 1SR139-600	15	AB40-C1000G to AB380-C1000G	201
1SR153-100 to 1SR153-400	39	AB40-C1500RG to AB380-C1500RG	201
1SR154-400 to 1SR154-600	15	ABR1000 to ABR1010	203
1SR35-100 to 1SR35-400	15	ABR1500 to ABR1510	203
1SS106 to 1SS108	66	ABR1500W to ABR1510W	203
1SS130 to 1SS133	24	ABR2500 to ABR2510	203
1SS165 to 1SS166	66	ABR2500W to ABR2510W	203
1SS176 to 1SS178	25	ABR3500 to ABR3510	204
1SS181 to 1SS187	26	ABR3500W to ABR3510W	204
1SS198 to 1SS199	66	ABR5000 to ABR5010	204
1SS226	26	ABR5000W to ABR5010W	204
1SS270A	25	ABR600 to ABR610	202
1SS286	66	ABR800 to ABR810	202
1SS294	68	AG01 Series	50
1SS355	26	AK03 to AK09	57
1SS388	68	AKBL400 to AKBL410	202
1SS88	66	AKBP200 to AKBP210	202
21DQ09	58	AP01C	37
21DQ10	58	AR2500 to AR2512	32
2EZ3.6D10 to 2EZ330D10	128	AR2500L to AR2512L	32
2EZ3.6D5 to 2EZ330D5	128	AR3500 to AR3512	32
2KBP005 to 2KBP10	189	AR3500L to AR3512L	32
2W005 to 2W10	188	AR5000 to AR5012	32
3.0SMCJ11 to 3.0SMCJ220A	160-161	AR5000L to AR5012L	32
3.0SMCJ11C to 3.0SMCJ220CA	160-161	AU01Series	37
30DF6	44	AU02 Series	38
30KP Series	172-173	AW005G to AW10G	201
31DQ03 to 31DQ10	61	AWL005G to AWL10G	201
3EZ3.9D10 to 3EZ200D10	132	B40-C1000 to B380-C1000	188
3EZ3.9D5 to 3EZ200D5	132	B40-C1500R to B380-C1500R	188
3JH45	44	BA157 to BA159	40
3KE Series	162-163	BAS116	27



Numerical Index

Type No.	Page	Type No.	Page
BAS15	25	BR600 to BR610	192
BAS16	27	BR800 to BR810	193
BAS16WS	26	BY133	14
BAS19 to BAS21	27	BY133G	22
BAS316	26	BY251 to BY255	19
BAS321	26	BY296 to BY299	42
BAS516	26	BY396 to BY399	43
BAS521	26	BY550-50 to BY550-1000	20
BAS70-00 to BAS70-06	27	BY8004 to BY8006	30
BAS85 to BAS86	66	BYD13D to BYD13M	33
BAT41 to BAT48	66	BYD17D to BYD17M	33
BAT42W to BAT43W	68	BYD33D to BYD33M	34
BAT42WS to BAT43WS	68	BYD37D to BYD37M	35
BAT54 Series.	68	BYD37DA to BYD37MA	35
BAT54W	68	BYD57D to BYD57V	35
BAT81 to BAT86	66	BYD77A to BYD77G	36
BAV10 to BAV21	25	BYG10D to BYG10M	34
BAV100 to BAV105	25	BYG20D to BYG20J	35
BAV19WS to BAV21WS	26	BYG24D to BYG24J	35
BAV23 Series	27	BYT52A to BYT52M	41
BAV70	27	BYT56A to BYT56M	43
BAV99	27	BYV26A to BYV26E	34
BAW56	27	BYV27-100 to BYV27-200	36
BAW62 to BAW76	25	BYV36A to BYV36E	34
BAX12 to BAX12A	34	BYV95A to BYV95C	34
BAX14 to BAX18	25	BYV96D to BYV96E	34
BAY80	25	BYW27-50 to BYW27-1000	14
BR1000 to BR1010	193	BYW32 to BYW36	42
BR1500 to BR1510	194	BYW54 to BYW56	33
BR1500W to BR1510W	194	BYW95A to BYW95C	36
BR2500 to BR2510	195	BYW96D to BYW95E	36
BR2500W to BR2510W	195	BYX134GPL	33
BR3500 to BR3510	197	BYX134PL	33
BR3500W to BR3510W	197	BZG03 Series	133
BR5000 to BR5010	197	BZG04 Series	134
BR5000W to BR5010W	197	BZG05 Series	135



Numerical Index

Type No.	Page	Type No.	Page
BZV55B Series	93	EDF1AM to EDF1DM	200
BZV55C Series	93	EDF1AS to EDF1DS	200
BZW04 Series	139-140	EG01 Series	50
BZW06 Series	147-148	EG1 Series	50
BZW50 Series	166	EGP20A to EGP20D	52
BZX384C Series	69	EK03 to EK04	58
BZX55B Series	92	EL1 Series	52
BZX55C Series	92	EM01 Series	15
BZX79B Series	94	EM1Series	15
BZX79C Series	94	EM2 Series	17
BZX85B Series	123	EP01C	37
BZX85C Series	123	ERA15-01 to ERA15-10	15
CN18A to CN18M	31	ERA22-02 to ERA22-10	37
CN25A to CN25M	31	ERA32-01 to ERA32-02	50
CN3A to CN3M	31	ERA34-10	37
CN5A to CN5M	31	ERA81-004	57
CN8A to CN8M	31	ERA83-004 to ERA83-006	57
CRS08	68	ERA84-009	57
D20XB20 to D20XB60	195	ERB12-01 to ERB12-10	15
D25XB20 to D25XB60	195	ERB38-04 to ERB06	39
D32P to D60P	209	ERB43-02 to ERB43-08	37
D3SB10 to D3SB80	192	ERB44-02 to ERB44-10	39
D3SBA10 to D3SBA80	192	ERB81-004	59
D5SBA10 to D5SBA60	192	ERB83-004 to ERB83-006	59
DB101 to DB107	198	ERB84-009	59
DB3	209	ERC04-02 to ERC04-10	17
DB4	209	ERC05-06 to ERC05-10	17
DF005M to DF10M	199	ERC25-04 to ERC25-06	17
DF005S to DF10S	198	ERC81-004 to ERC81-006	60
DF15005M to DF1510M	199	ERC84-009	60
DF15005S to DF1510S	199	ERD07-13 to ERD07-15	18
DL201 to DL207	19	ERD28-04 to ERD28-08	42
DL4001 to DL4007	22	ES1 Series	38
DL4933 to DL4937	40	ES1A to ES1M	51
DR200 to DR210	19	ES2A to ES2D	53
DR200G to DR210G	23	ES2AA to ES2DA	53



Numerical Index

Type No.	Page	Type No.	Page
ES3A to ES3M	54	FR101 to FR107-STR	40
ESAC25 Series	45	FR101G to FR107G-STR	46
ESD5B5.0	185	FR151 to FR157-STR	41
ESD5Z3.3	185	FR151G to FR157G-STR	46
ESD5Z5.0	185	FR201 to FR207-STR	43
ESD5Z6.0	185	FR201G to FR207G-STR	47
ESD5Z7.0	185	FR251 to FR257-STR	43
ESD9B5V	185	FR251G to FR257G-STR	47
ESD9X5V	185	FR301 to FR307-STR	44
ESDA5V3L	186	FR301G to FR307G-STR	47
ESDA6V1L	186	FR501 to FR507	45
ET013 to ET020	209	FR601 to FR607	45
EU1 Series	37	FR801 to FR805	45
EU2 Series	39	FST10120 to FST10200	64
F1200A	45	FST20120 to FST20200	65
F1200D	45	FST31120 to FST31200	65
F2W005G to F2W10G	205	FW005G to FW10G	205
FB40-C1000G to FB380-C1000G	205	FWL005G to FWL10G	205
FB40-C1500RG to FB380-C1500RG	205	G105 to G270	209
FBR1000 to FBR1010	207	G105C to G270C	209
FBR1500 to FBR1510	207	GBJ2500 to GBJ2510	196
FBR1500W to FBR1510W	207	GBPC25005 to GBPC2510	187
FBR2500 to FBR2510	207	GBPC6005 to GBPC610	187
FBR2500W to FBR2510W	207	GBU4A to GBU4M	189
FBR3500 to FBR3510	208	GBU8005 to GBU810	191
FBR3500W to FBR3510W	208	GBU8A to GBU8M	191
FBR5000 to FBR5010	208	GDZ2.0B to GDZ36B	70
FBR5000W to FBR5010W	208	GF1A to GF1M	22
FBR600 to FBR610	206	GLZ Series	95-96
FBR800 to FBR810	206	GN13	22
FEP16AP to FEP16JP	55	GN1A to GN1M	22
FEP30AP to FEP30JP	55	GN2A to GN2M	23
FES16AT to FES16JT	55	GN3A to GN3M	23
FES8AT to FES8JT	55	GNOA to GNOM	23
FKBL400 to FKBL410	206	GNTA to GNTM	23
FKBP200 to FKBP210	206	GP02-20 to GP02-40	28



Numerical Index

Type No.	Page	Type No.	Page
GP15A to GP15M	18	KBPC3500 to KBPC3510	197
GR15-G	30	KBPC5000 to KBPC5010	197
GR1A to GR1M	46	KBU4A to KBU4M	189
GR20-G	30	KBU6A to KBU6M	189
GR2A to GR2M	47	KBU8A to KBU8M	189
GR3A to GR3M	47	LCE Series	177-178
GRN3 to GRN7	46	LL101A to LL101C	67
GS1S	30	LL103A to LL103C	67
HER101 to HER108	48	LL41 to LL48	66
HER151 to HER158	48	LL4148 to LL4153	25
HER201 to HER208	48	LL4448	25
HER251 to HER258	49	LL5711	66
HER301 to HER308	49	LL5817 to LL5819	57
HER501 to HER508	49	LL6263	66
HER601 to HER608	49	LMN1A to LMN1M	22
HFR125 to HFR130	30	LMR1A to LMR1M	46
HFR180	30	LMS1A to LMS1M	56
HSS100 to HSS102	66	MA2Z748	68
HVR112 to HVR120	28	MA700 to MA700A	67
HVR125 to HVR180	28	MB1M to MB10M	198
HVR230 to HVR250	28	MB1S to MB10S	198
HVR312 to HVR320	29	MBR0520L	68
HVR512 to HVR520	29	MBR0530	68
HZKxxL Series	80-81	MBR0540	68
HZKxxLL Series	73	MBR1035 to MBR1060	62
HZSxx Series	74	MBR150 to MBR160	58
HZSxxL Series	82-83	MBR1635 to MBR1660	62
HZSxxLL Series	75	MBR1660CT to MBR16100CT	62
HZxx Series	97	MBR16H35 to MBR16H60	62
HZxxL Series	79	MBR20200CT	65
KBL400 to KBL410	189	MBR2035CT to MBR2060CT	62
KBL400G to KBL410G	187	MBR2535CT to MBR2560CT	63
KBP200 to KBP210	189	MBR3035PT to MBR3060PT	63
KBPC1000 to KBPC1010	194	MBR320 to MBR360	60
KBPC1500 to KBPC1510	195	MBR4035PT to MBR4060PT	63
KBPC2500 to KBPC2510	196	MBR735 to MBR760	61



Numerical Index

Type No.	Page	Type No.	Page
MBRF16H35 to MBRF16H60	62	MR750 to MR756	32
MBRF20200CT	65	MR850 to MR858	44
MBRS1100	64	MRA4003 to MRA4007	16
MBRS120T3	64	MS10180 to MS10200	64
MBRS130LT3	64	MS16180 to MS16200	64
MBRS140	64	MS20180 to MS20200	65
MBRS240LT3G	64	MSMF05C	186
MBRS3100	64	MSQA6V1W5	185
MBRS3200	64	MTZJ Series	102
MBRS3201	64	MUR120 to MUR160	50
MBRS330T3	64	MUR3020PT to MUR3040PT	25
MBRS340T3	64	MZ1110 to MZ1200	113
MBRS360T3	64	MZ4728 to MZ4764	113
MBRS4201	64	MZ55C3V0 to MZ55C200	103
MM1Z2V0B Series	99	MZ5913A to MZ5956A	126
MM1Z2V4 Series	98	MZ5913B to MZ5956B	126
MM1Z4678 Series	100	MZ85C3V0 to MZ85C200	124
MM3Z2V0 Series	76	NS8AT to NS8MT	21
MM3Z2V0B Series	77	NZQA6V8	185
MM5Z2B4 Series	72	P4KE Series	141-143
MM5Z2V4 Series,	71	P600A to P600M	21
MMBD4148 Series	27	P6KE Series	149-150
MMBD914	27	P6SMB Series	151
MMBZ5221B Series	78	P800A to P800K	21
MMSD4148	26	PTZ Series	116
MMSZ5221B Series	101	PZ628	183
MMZJ Series	102	R2G to R2M	33
MR2500 to MR2512	32	R2KY	33
MR2500L to MR2512L	32	RB150 to RB158	189
MR2535 to MR2540	183	RB441Q-40	67
MR2535L to MR2540L	183	RB721Q-40	67
MR3230	183	RBV1000 to RBV1010	193
MR3501 to MR3512	32	RBV1000D to RBV1010D	194
MR3501L to MR3512L	32	RBV1500 to RBV1510	194
MR5000 to MR5012	32	RBV1500D to RBV1510D	194
MR5000L to MR5012L	32	RBV2500 to RBV2510	195



Numerical Index

Type No.	Page	Type No.	Page
RBV2500D to RBV2510D	196	RU1 Series	37
RBV3500 to RBV3510	197	RU2 Series	41
RBV401 to RBV410	192	RU3 Series	42
RBV5000 to RBV5010	197	RU4 Series	42
RBV600 to RBV610	192	S15VB20 to S15VB60	195
RBV600D to RBV610D	193	S1A to S1M	16
RBV800 to RBV810	193	S1T	28
RBV800D to RBV810D	193	S1ZB20 to S1ZB80	198
RD2.0E to RD39E	104-106	S25VB20 to S25VB60	196
RD2.0ES to RD39ES	84-86	S2A to S2M	18
RD2.0F to RD82F	117-119	S5277B to S5277N	16
RD4.7JS to RD39JS	87-88	S5295B to S5295J	38
RG10 Series	50	S5566B to S5566N	16
RG2 Series	52	S5688B to S5688N	16
RG4 Series	52	S5KP Series	167-168
RGF1A to RGF1M	40	SA Series	145-146
RGP02-12E to RGP02-20E	30	SAC Series	174
RGP10A to RGP10M	39	SB0015-03A	67
RGP15A to RG15M	41	SB0030-01A	67
RGP20A to RGP20J	43	SB120 to SB1B0	57
RGP30A to RGP30M	44	SB220 to SB2B0	59
RH1 Series	38	SB220S to SB2B0S	59
RK13 to RK19	58	SB320 to SB3B0	60
RK33 to RK39	59	SB320S to SB3B0S	60
RK43 to RK49	61	SB520 to SB5B0	61
RL251 to RL257	19	SB520S to SB5B0S	61
RLZ Series	107	SBL1030 to SBL1040	61
RM10 Series	17	SBL1030CT to SBL1640CT	62
RM11A to RM11C	17	SBL2030PT to SBL2040PT	63
RM2 Series	17	SBL3030PT to SBL3040PT	63
RM25	33	SBL4030PT to SBL4040PT	63
RM3 Series	19	SBO20 to SBOB0	59
RM4 Series	18	SBT20 to SBTB0	60
RMB2S to RMB4S	200	SD05	185
RS1A to RS1M	40	SD101A to SD101C	67
RS3A to RS3K	44	SD101AWS to SD101CWS	68



Numerical Index

Type No.	Page	Type No.	Page
SD103A to SD103C	67	SM8S Series	169
SD103AWS to SD103CWS	68	SMAJ5.0 Series.	143-144
SD12	185	SMAZ Series	120
SE1A to SE1M	48	SMBJ5.0 Series.	152-153
SE2A to SE2M	48	SMBJ5333A to SMBJ5388A	137
SE3A to SE3M	49	SMBJ5333B to SMBJ5388B	137
SE5A to SE5M	49	SMBJ-LC5.0 to SMBJ-LC188A	175-176
SEOA to SEOM	48	SMCJ5.0 Series.	158-159
SETA to SETM	49	SMCJLCE6.5 to SMCJLCE170A	179-180
SF11 to SF19	51	SME1A to SME1M	48
SF11G to SF19G	56	SMF5.0A Series	138
SF21 to SF29	53	SMK1A to SMK1M	57
SF31 to SF39	54	SML4728 to SML4764	121
SF51 to SF59	54	SML4728A to SML4764A	121
SF61 to SF69	54	SMN1A to SMN1M	22
SFO1 to SFO9	52	SMR1A to SMR1M	46
SFT1 to SFT9	53	SMS1A to SMS1M	56
SHV-01JN	28	SMZ15xx Series	113
SHV-02	29	SMZ25xx Series	124
SHV-04	29	SMZ35xx Series	126
SHV-05J	28	SN13	14
SHV-06HK	29	SN1A to SN1M	14
SK12 to SK1B	57	SN1N to SN1R	28
SK22 to SK2B	59	SN21 to SN25	19
SK22S to SK2BS	59	SN2A to SN2M	19
SK32 to SK3B	60	SN3A to SN3M	20
SK32A to SK3BA	60	SN3AS to SN3MS	20
SK32S to SK3BS	60	SN3N to SN3R	29
SK52 to SK5B	61	SN5A to SN5M	20
SK52S to SK5BS	61	SN5N to SN5R	29
SKN0 to SKN2	60	SNOA to SNOM	18
SKN0S to SKN2S	60	SNWA to SNWM	14
SKN7 to SKN9	57	SR1A to SR1M	40
SL12 to SL13	58	SR1P	30
SLVU2.8	185	SR1R	30
SLVU2.8-4	185	SR220 to SR2100	59



Numerical Index

Type No.	Page	Type No.	Page
SR26 to SR29	42	SZ45 Series	128
SR2A to SR2M	43	SZ50 Series	132
SR36 to SR39	43	SZ55 Series	132
SR3A to SR3M	44	SZ60 Series	136
SR520 to SR560	61	SZ65 Series	136
SRA7 to SRA9	40	TPSMC Series	184
SRDA3.3-4	186	TVR1B to TVR1J	38
SRN3 to SRN7	40	TVR2B to TVR2J	38
SROA to SROM	41	TZMC Series	108
SRR0 to SRR6	44	UF1001 to UF1007	51
SRTA to SRTM	43	UF4001 to UF4007	51
SS1A to SS1M	51	UF5404 to UF5408	53
SS2A to SS2M	53	UG2A to UG2D	52
SS3A to SS3M	54	ULCE Series	181-182
SS5A to SS5M	54	W005 to W10	188
SSOA to SSOM	52	W005G to W10G	187
SSTA to SSTM	53	WL005 to WL10	188
STB6 Series	149-150	Z043 to Z0200	110
STBB Series	139-140	Z043A to Z0200A	110
STBK Series	156-157	Z043B to Z0200B	110
STBN Series	154-155	Z1110 to Z1300	112
STBP Series	141-142	Z1110A to Z1300A	112
STBS Series	145-146	ZM4728A to ZM4764A	114
STU6 Series	149-150	ZMM2.4 to ZMM75	109
STUB Series	139-140	ZMM5225 to ZMM5267	89
STUK Series	156-157	ZMM5225B to ZMM5267B	89
STUN Series	154-155	ZMU100 to ZMU180	122
STUP Series	141-142	ZMY Series	122
STUS Series	145-146	ZPD Series	111
SZ10 Series	112	ZPY Series	125
SZ15 Series	112	ZY Series	129
SZ25 Series	123		
SZ30 Series	130		
SZ35 Series	130		
SZ40 Series	128		

Silicon Rectifier Diodes

The plastic material carries U/L recognition 94V-O.

Type No.		Max. Average Forward Rectified Current		Max. Repetitive Peak Reverse Voltage	Max. Repetitive Peak Forward Current	Max. Peak Forward Surge Current	Max. Forward Voltage Drop at Ta = 25°C		Max. Reverse Current at Ta = 25°C
		I _{F(AV)}	@ Ta	V _{RRM}	I _{FRM}	I _{FSM}	V _F	@ I _F	I _R
Axial Lead	SMD	(A)	(°C)	(V)	(A)	(A)	(V)	(A)	(µA)

1A1 Series, 1 A, Case Type: R-1



1A1		1.0	50	50	-	30	1.1	1.0	5.0
1A2		1.0	50	100	-	30	1.1	1.0	5.0
1A3		1.0	50	200	-	30	1.1	1.0	5.0
1A4		1.0	50	400	-	30	1.1	1.0	5.0
1A5		1.0	50	600	-	30	1.1	1.0	5.0
1A6		1.0	50	800	-	30	1.1	1.0	5.0
1A7		1.0	50	1000	-	30	1.1	1.0	5.0

1N4001/SN1A Series, 1 A, Case Type: DO-41/SMA



1N4001	SN1A	1.0	75	50	10	30	1.0	1.0	5.0
1N4002	SN1B	1.0	75	100	10	30	1.0	1.0	5.0
1N4003	SN1D	1.0	75	200	10	30	1.0	1.0	5.0
1N4004	SN1G	1.0	75	400	10	30	1.0	1.0	5.0
1N4005	SN1J	1.0	75	600	10	30	1.0	1.0	5.0
1N4006	SN1K	1.0	75	800	10	30	1.0	1.0	5.0
1N4007	SN1M	1.0	75	1000	10	30	1.0	1.0	5.0
BY133	SN13	1.0	75	1300	10	30	1.0	1.0	5.0
1N4003ST		1.0	75	200	-	30	1.1	1.0	5.0

BYW27/SNWA Series, 1 A, Case Type: DO-41/SMA



BYW27-50	SNWA	1.0	70	50	10	50	1.0	1.0	0.2
BYW27-100	SNWB	1.0	70	100	10	50	1.0	1.0	0.2
BYW27-200	SNWD	1.0	70	200	10	50	1.0	1.0	0.2
BYW27-400	SNWG	1.0	70	400	10	50	1.0	1.0	0.2
BYW27-600	SNWJ	1.0	70	600	10	50	1.0	1.0	0.2
BYW27-800	SNWK	1.0	70	800	10	50	1.0	1.0	0.2
BYW27-1000	SNWM	1.0	70	1000	10	50	1.0	1.0	0.2

11E1 Series, 1 A, Case Type: DO-41



11E1		1.0	40	100	-	45	1.0	1.0	50
11E2		1.0	40	200	-	45	1.0	1.0	50
11E4		1.0	40	400	-	45	1.0	1.0	10
11E6		1.0	40	600	-	45	1.0	1.0	10

11ES1 Series, 1 A, Case Type: DO-41



11ES1		1.0	40	100	-	45	1.0	1.0	50
11ES2		1.0	40	200	-	45	1.0	1.0	50



Silicon Rectifier Diodes

The plastic material carries U/L recognition 94V-O.

Type No.		Max. Average Forward Rectified Current		Max. Repetitive Peak Reverse Voltage	Max. Repetitive Peak Forward Current	Max. Peak Forward Surge Current	Max. Forward Voltage Drop at Ta = 25°C		Max. Reverse Current at Ta = 25°C
		I _{F(AV)}	@ Ta				V _F	@ I _F	
Axial Lead	SMD	(A)	(°C)	(V)	(A)	(A)	(V)	(A)	(µA)

1SR35-100 Series, 1 A, Case Type: DO-41



1SR35-100		1.0	50	100	-	30	1.1	1.0	10
1SR35-200		1.0	50	200	-	30	1.1	1.0	10
1SR35-400		1.0	50	400	-	30	1.1	1.0	10

1SR139-100 Series, 1 A, Case Type: DO-41



1SR139-100		1.0	25	100	-	40	1.1	1.0	10
1SR139-200		1.0	25	200	-	40	1.1	1.0	10
1SR139-400		1.0	25	400	-	40	1.1	1.0	10
1SR139-600		1.0	25	600	-	40	1.1	1.0	10

1SR154-400 Series, 1 A, Case Type: SMA



	1SR154-400	1.0	25	400	-	30	1.1	1.0	10
	1SR154-600	1.0	25	600	-	30	1.1	1.0	10

EM01 Series, 1 A, Case Type: DO-41



EM01		1.0	25	400	-	45	0.97	1.0	10
EM01A		1.0	25	600	-	45	0.97	1.0	10
EM01Z		1.0	25	200	-	45	0.97	1.0	10

EM1 Series, 1 A, Case Type: DO-41



EM1		1.0	25	400	-	45	0.97	1.0	10
EM1A		1.0	25	600	-	45	0.97	1.0	10
EM1B		1.0	25	800	-	35	0.97	1.0	20
EM1C		1.0	25	1000	-	35	0.97	1.0	20

ERA15-01 Series, 1 A, Case Type: DO-41



ERA15-01		1.0	40	100	-	40	1.1	2.0	10
ERA15-02		1.0	40	200	-	40	1.1	2.0	10
ERA15-04		1.0	40	400	-	40	1.1	2.0	10
ERA15-06		1.0	40	600	-	40	1.1	2.0	10
ERA15-08		1.0	25	800	-	40	1.1	2.0	10
ERA15-10		1.0	25	1000	-	40	1.1	2.0	10

ERB12-01 Series, 1 A, Case Type: DO-41



ERB12-01		1.0	60	100	-	60	1.1	2.0	10
ERB12-02		1.0	60	200	-	60	1.1	2.0	10
ERB12-04		1.0	60	400	-	60	1.1	2.0	10
ERB12-06		1.0	60	600	-	60	1.1	2.0	10
ERB12-10		1.0	25	1000	-	50	1.1	2.0	10

Silicon Rectifier Diodes

The plastic material carries U/L recognition 94V-O.

Type No.		Max. Average Forward Rectified Current		Max. Repetitive Peak Reverse Voltage	Max. Repetitive Peak Forward Current	Max. Peak Forward Surge Current	Max. Forward Voltage Drop at Ta = 25°C		Max. Reverse Current at Ta = 25°C
		I _{F(AV)}	@ Ta				V _F	@ I _F	
Axial Lead	SMD	(A)	(°C)	(V)	(A)	(A)	(V)	(A)	(µA)

MRA4003 Series, 1 A, Case Type: SMA



	MRA4003	1.0	150 (T _L)	300	-	30	1.18	2.0	10
	MRA4004	1.0	150 (T _L)	400	-	30	1.18	2.0	10
	MRA4005	1.0	150 (T _L)	600	-	30	1.18	2.0	10
	MRA4006	1.0	150 (T _L)	800	-	30	1.18	2.0	10
	MRA4007	1.0	150 (T _L)	1000	-	30	1.18	2.0	10

S1A Series, 1 A, Case Type: SMA



	S1A	1.0	110 (T _L)	50	-	40	1.1	1.0	1.0
	S1B	1.0	110 (T _L)	100	-	40	1.1	1.0	1.0
	S1D	1.0	110 (T _L)	200	-	40	1.1	1.0	1.0
	S1G	1.0	110 (T _L)	400	-	40	1.1	1.0	1.0
	S1J	1.0	110 (T _L)	600	-	40	1.1	1.0	1.0
	S1K	1.0	100 (T _L)	800	-	30	1.1	1.0	5.0
	S1M	1.0	100 (T _L)	1000	-	30	1.1	1.0	5.0

S5277 Series, 1.0 A, Case Type: DO-41



S5277B		1.0	25	100	-	55	1.2	1.0	10
S5277G		1.0	25	400	-	55	1.2	1.0	10
S5277J		1.0	25	600	-	33	1.2	1.0	10
S5277N		1.0	25	1000	-	33	1.2	1.0	10

S5566B Series, 1 A, Case Type: DO-41



S5566B		1.0	25	100	-	45	1.2	1.0	10
S5566G		1.0	25	400	-	45	1.2	1.0	10
S5566J		1.0	25	600	-	30	1.2	1.0	10
S5566N		1.0	25	1000	-	30	1.2	1.0	10

S5688B Series, 1 A, Case Type: R-1



S5688B		1.0	30	100	-	45	1.2	1.0	10
S5688G		1.0	30	400	-	45	1.2	1.0	10
S5688J		1.0	30	600	-	30	1.2	1.0	10
S5688N		1.0	30	1000	-	30	1.2	1.0	10

1S1885 Series, 1 A, Case Type: D2



1S1885		1.0	65	100	-	60	1.2	1.5	10
1S1886		1.0	65	200	-	60	1.2	1.5	10
1S1887		1.0	65	400	-	60	1.2	1.5	10
1S1888		1.0	65	600	-	60	1.2	1.5	10

Silicon Rectifier Diodes

The plastic material carries U/L recognition 94V-O.

Type No.		Max. Average Forward Rectified Current		Max. Repetitive Peak Reverse Voltage	Max. Repetitive Peak Forward Current	Max. Peak Forward Surge Current	Max. Forward Voltage Drop at Ta = 25°C		Max. Reverse Current at Ta = 25°C
		I _{F(AV)}	@ Ta				V _F	@ I _F	
Axial Lead	SMD	(A)	(°C)	(V)	(A)	(A)	(V)	(A)	(µA)

EM2 Series, 1.2 A, Case Type: DO-41



EM2		1.2	25	400	-	80	0.92	1.2	10
EM2A		1.2	25	600	-	80	0.92	1.2	10
EM2B		1.2	25	800	-	80	0.92	1.2	10

ERC04-02 Series, 1.2 A, Case Type: D2A



ERC04-02		1.2	60	200	-	100	1.1	4.0	10
ERC04-04		1.2	60	400	-	100	1.1	4.0	10
ERC04-06		1.2	60	600	-	100	1.1	4.0	10
ERC04-10		1.2	60	1000	-	100	1.1	4.0	10

ERC05-06 Series, 1.2 A, Case Type: D2



ERC05-06		1.2	60	600	-	100	1.00	4.0	10
ERC05-08		1.2	60	800	-	100	1.00	4.0	10
ERC05-10		1.2	60	1000	-	100	1.00	4.0	10

ERC25-04 Series, 1.2 A, Case Type: D2



ERC25-04		1.2	40	400	-	50	1.10	1.2	10
ERC25-06		1.2	40	600	-	50	1.10	1.2	10

RM11A Series, 1.2 A, Case Type: D2



RM11A		1.2	70	600	15	100	0.92	1.5	10
RM11B		1.2	70	800	15	100	0.92	1.5	10
RM11C		1.2	70	1000	15	100	0.92	1.5	10

RM2 Series, 1.2 A, Case Type: D2A



RM2Z		1.2	70	200	15	100	0.91	1.5	10
RM2		1.2	70	400	15	100	0.91	1.5	10
RM2A		1.2	70	600	15	100	0.91	1.5	10
RM2B		1.2	70	800	15	100	0.91	1.5	10
RM2C		1.2	70	1000	15	100	0.91	1.5	10

RM10 Series, 1.2 - 1.5 A, Case Type: D2



RM10		1.2	70	400	15	150	0.91	1.5	10
RM10A		1.2	70	600	15	150	0.91	1.5	10
RM10B		1.2	70	800	15	150	0.91	1.5	10
RM10Z		1.5	70	200	15	120	0.91	1.5	10

Silicon Rectifier Diodes

The plastic material carries U/L recognition 94V-O.

Type No.		Max. Average Forward Rectified Current		Max. Repetitive Peak Reverse Voltage	Max. Repetitive Peak Forward Current	Max. Peak Forward Surge Current	Max. Forward Voltage Drop at Ta = 25°C		Max. Reverse Current at Ta = 25°C
		I _{F(AV)}	@ Ta	V _{RRM}	I _{FRM}	I _{FSM}	V _F	@ I _F	I _R
Axial Lead	SMD	(A)	(°C)	(V)	(A)	(A)	(V)	(A)	(µA)

1N5391/SNOA Series, 1.5 A, Case Type: DO-41/SMA



1N5391	SNOA	1.5	70	50	10	50	1.1	1.5	5.0
1N5392	SNOB	1.5	70	100	10	50	1.1	1.5	5.0
1N5393	SNOD	1.5	70	200	10	50	1.1	1.5	5.0
1N5394	SNOE	1.5	70	300	10	50	1.1	1.5	5.0
1N5395	SNOG	1.5	70	400	10	50	1.1	1.5	5.0
1N5396	SNOH	1.5	70	500	10	50	1.1	1.5	5.0
1N5397	SNOJ	1.5	70	600	10	50	1.1	1.5	5.0
1N5398	SNOK	1.5	70	800	10	50	1.1	1.5	5.0
1N5399	SNOM	1.5	70	1000	10	50	1.1	1.5	5.0

GP15A Series, 1.5 A, Case Type: D2



GP15A		1.5	55	50	-	50	1.10	1.5	5.0
GP15B		1.5	55	100	-	50	1.10	1.5	5.0
GP15D		1.5	55	200	-	50	1.10	1.5	5.0
GP15G		1.5	55	400	-	50	1.10	1.5	5.0
GP15J		1.5	55	600	-	50	1.10	1.5	5.0
GP15K		1.5	55	800	-	50	1.10	1.5	5.0
GP15M		1.5	55	1000	-	50	1.10	1.5	5.0

S2A Series, 1.5 A, Case Type: SMB



	S2A	1.5	75 (T _L)	50	-	50	1.15	1.5	1.0
	S2B	1.5	75 (T _L)	100	-	50	1.15	1.5	1.0
	S2D	1.5	75 (T _L)	200	-	50	1.15	1.5	1.0
	S2G	1.5	75 (T _L)	400	-	50	1.15	1.5	1.0
	S2J	1.5	75 (T _L)	600	-	50	1.15	1.5	1.0
	S2K	1.5	75 (T _L)	800	-	50	1.15	1.5	1.0
	S2M	1.5	75 (T _L)	1000	-	50	1.15	1.5	1.0

ERD07-13 Series, 1.5 A, Case Type: DO-201AD



ERD07-13		1.5	125(T _L)	1300	-	50	1.2	4.0	10
ERD07-15		1.5	125(T _L)	1500	-	50	1.2	4.0	10

RM4 Series, 1.7 A, Case Type: DO-201AD



RM4Y		1.7	40	100	-	150	0.95	3.0	10
RM4Z		1.7	40	200	-	150	0.95	3.0	10
RM4		1.7	40	400	-	150	0.95	3.0	10



Silicon Rectifier Diodes

The plastic material carries U/L recognition 94V-O.

Type No.		Max. Average Forward Rectified Current		Max. Repetitive Peak Reverse Voltage	Max. Repetitive Peak Forward Current	Max. Peak Forward Surge Current	Max. Forward Voltage Drop at Ta = 25°C		Max. Reverse Current at Ta = 25°C
		I _{F(AV)}	@ Ta				V _F	@ I _F	
Axial Lead	SMD	(A)	(°C)	(V)	(A)	(A)	(V)	(A)	(µA)

DL201 Series, 2 A, Case Type: D2



DL201		2.0	50	50	-	75	1.0	2.0	5.0
DL202		2.0	50	100	-	75	1.0	2.0	5.0
DL203		2.0	50	200	-	75	1.0	2.0	5.0
DL204		2.0	50	400	-	75	1.0	2.0	5.0
DL205		2.0	50	600	-	75	1.0	2.0	5.0
DL206		2.0	50	800	-	75	1.0	2.0	5.0
DL207		2.0	50	1000	-	75	1.0	2.0	5.0

DR200/SN2A Series, 2 A, Case Type: D2/SMB



DR200	SN2A	2.0	50	50	15	75	1.0	2.0	5.0
DR201	SN2B	2.0	50	100	15	75	1.0	2.0	5.0
DR202	SN2D	2.0	50	200	15	75	1.0	2.0	5.0
DR204	SN2G	2.0	50	400	15	75	1.0	2.0	5.0
DR206	SN2J	2.0	50	600	15	75	1.0	2.0	5.0
DR208	SN2K	2.0	50	800	15	75	1.0	2.0	5.0
DR210	SN2M	2.0	50	1000	15	75	1.0	2.0	5.0

RL251 Series, 2.5 A, Case Type: D2A



RL251		2.5	75	50	-	150	1.1	2.5	5
RL252		2.5	75	100	-	150	1.1	2.5	5
RL253		2.5	75	200	-	150	1.1	2.5	5
RL254		2.5	75	400	-	150	1.1	2.5	5
RL255		2.5	75	600	-	150	1.1	2.5	5
RL256		2.5	75	800	-	150	1.1	2.5	5
RL257		2.5	75	1000	-	150	1.1	2.5	5

RM3 Series, 2.5 A, Case Type: DO-201AD



RM3		2.5	50	400	-	150	0.95	2.5	10
RM3A		2.5	50	600	-	150	0.95	2.5	10
RM3B		2.5	50	800	-	150	0.95	2.5	10

BY251/SN21 Series, 3 A, Case Type: DO-201AD/SMC



BY251	SN21	3.0	50	200	20	100	1.1	3.0	20
BY252	SN22	3.0	50	400	20	100	1.1	3.0	20
BY253	SN23	3.0	50	600	20	100	1.1	3.0	20
BY254	SN24	3.0	50	800	20	100	1.1	3.0	20
BY255	SN25	3.0	50	1300	20	100	1.1	3.0	20



Silicon Rectifier Diodes

The plastic material carries U/L recognition 94V-0.

Type No.		Max. Average Forward Rectified Current		Max. Repetitive Peak Reverse Voltage	Max. Repetitive Peak Forward Current	Max. Peak Forward Surge Current	Max. Forward Voltage Drop at Ta = 25°C		Max. Reverse Current at Ta = 25°C
		I _{F(AV)}	@ Ta	V _{RRM}	I _{FRM}	I _{FSM}	V _F	@ I _F	I _R
Axial Lead	SMD	(A)	(°C)	(V)	(A)	(A)	(V)	(A)	(µA)

1N5400 /SN3A Series, 3 A, Case Type: DO-201AD/SMC



1N5400	SN3A	3.0	75	50	30	200	1.0	3.0	5.0
1N5401	SN3B	3.0	75	100	30	200	1.0	3.0	5.0
1N5402	SN3D	3.0	75	200	30	200	1.0	3.0	5.0
1N5404	SN3G	3.0	75	400	30	200	1.0	3.0	5.0
1N5406	SN3J	3.0	75	600	30	200	1.0	3.0	5.0
1N5407	SN3K	3.0	75	800	30	200	1.0	3.0	5.0
1N5408	SN3M	3.0	75	1000	30	200	1.0	3.0	5.0

SN3AS Series, 3.0 A, Case Type: SMB



	SN3AS	3.0	75	50	-	200	1.2	3.0	5.0
	SN3BS	3.0	75	100	-	200	1.2	3.0	5.0
	SN3DS	3.0	75	200	-	200	1.2	3.0	5.0
	SN3GS	3.0	75	400	-	200	1.2	3.0	5.0
	SN3JS	3.0	75	600	-	200	1.2	3.0	5.0
	SN3KS	3.0	75	800	-	200	1.2	3.0	5.0
	SN3MS	3.0	75	1000	-	200	1.2	3.0	5.0

BY550/SN5A Series, 5 A, Case Type: DO-201AD/SMC



BY550-50	SN5A	5.0	60	50	40	300	1.1	5.0	20
BY550-100	SN5B	5.0	60	100	40	300	1.1	5.0	20
BY550-200	SN5D	5.0	60	200	40	300	1.1	5.0	20
BY550-400	SN5G	5.0	60	400	40	300	1.1	5.0	20
BY550-600	SN5J	5.0	60	600	40	300	1.1	5.0	20
BY550-800	SN5K	5.0	60	800	40	300	1.1	5.0	20
BY550-1000	SN5M	5.0	60	1000	40	300	1.1	5.0	20

6A05 Series, 6 A, Case Type: D6



6A05		6.0	60	50	-	400	0.95	6.0	5.0
6A1		6.0	60	100	-	400	0.95	6.0	5.0
6A2		6.0	60	200	-	400	0.95	6.0	5.0
6A4		6.0	60	400	-	400	0.95	6.0	5.0
6A6		6.0	60	600	-	400	0.95	6.0	5.0
6A8		6.0	60	800	-	400	0.95	6.0	5.0
6A10		6.0	60	1000	-	400	1.00	6.0	5.0



Silicon Rectifier Diodes

The plastic material carries U/L recognition 94V-O.

Type No.		Max. Average Forward Rectified Current		Max. Repetitive Peak Reverse Voltage	Max. Repetitive Peak Forward Current	Max. Peak Forward Surge Current	Max. Forward Voltage Drop at Ta = 25°C		Max. Reverse Current at Ta = 25°C
		I _{F(AV)}	@ Ta	V _{RRM}	I _{FRM}	I _{FSM}	V _F	@ I _F	I _R
Axial Lead	SMD	(A)	(°C)	(V)	(A)	(A)	(V)	(A)	(µA)

P600A Series, 6 A, Case Type: D6



P600A		6.0	60	50	-	400	0.9	6.0	5.0
P600B		6.0	60	100	-	400	0.9	6.0	5.0
P600D		6.0	60	200	-	400	0.9	6.0	5.0
P600G		6.0	60	400	-	400	0.9	6.0	5.0
P600J		6.0	60	600	-	400	0.9	6.0	5.0
P600K		6.0	60	800	-	400	0.9	6.0	5.0
P600M		6.0	60	1000	-	400	1.0	6.0	5.0

P800A Series, 8 A, Case Type: D6



P800A		8.0	50	50	-	400	1.0	8.0	5.0
P800B		8.0	50	100	-	400	1.0	8.0	5.0
P800D		8.0	50	200	-	400	1.0	8.0	5.0
P800G		8.0	50	400	-	400	1.0	8.0	5.0
P800J		8.0	50	600	-	400	1.0	8.0	5.0
P800K		8.0	50	800	-	400	1.0	8.0	5.0

NS8AT Series, 8 A, Case Type: TO-220AC



NS8AT		8.0	100(Tc)	50	-	175	1.1	8.0	10
NS8BT		8.0	100(Tc)	100	-	175	1.1	8.0	10
NS8DT		8.0	100(Tc)	200	-	175	1.1	8.0	10
NS8GT		8.0	100(Tc)	400	-	175	1.1	8.0	10
NS8JT		8.0	100(Tc)	600	-	175	1.1	8.0	10
NS8KT		8.0	100(Tc)	800	-	175	1.1	8.0	10
NS8MT		8.0	100(Tc)	1000	-	175	1.1	8.0	10

10A01 Series, 10 A, Case Type: D6



10A01		10	50	50	-	600	1.3	10	10
10A02		10	50	100	-	600	1.3	10	10
10A03		10	50	200	-	600	1.3	10	10
10A04		10	50	400	-	600	1.3	10	10
10A05		10	50	600	-	600	1.3	10	10
10A06		10	50	800	-	600	1.3	10	10
10A07		10	50	1000	-	600	1.3	10	10



Glass Passivated Rectifier Diodes

The plastic material carries U/L recognition 94V-O.

Type No.		Max. Average Forward Rectified Current		Max. Repetitive Peak Reverse Voltage	Max. Repetitive Peak Forward Current	Max. Peak Forward Surge Current	Max. Forward Voltage Drop at Ta=25°C		Max. Reverse Current at Ta=25°C
		IF(AV)	@ Ta	VRRM	IFRM	IFSM	VF	@ IF	IR
Axial Lead	SMD	(A)	(°C)	(V)	(A)	(A)	(V)	(A)	(μA)

1G1 Series, 1 A, Case Type: R-1



1G1		1.0	50	50	-	30	1.1	1.0	5.0
1G2		1.0	50	100	-	30	1.1	1.0	5.0
1G3		1.0	50	200	-	30	1.1	1.0	5.0
1G4		1.0	50	400	-	30	1.1	1.0	5.0
1G5		1.0	50	600	-	30	1.1	1.0	5.0
1G6		1.0	50	800	-	30	1.1	1.0	5.0
1G7		1.0	50	1000	-	30	1.1	1.0	5.0

LMN1A/SMN1A Series, 1 A, Case Type: M1A/SOD-123FL



LMN1A	SMN1A	1.0	50	50	-	30	1.0	1.0	5.0
LMN1B	SMN1B	1.0	50	100	-	30	1.0	1.0	5.0
LMN1D	SMN1D	1.0	50	200	-	30	1.0	1.0	5.0
LMN1G	SMN1G	1.0	50	400	-	30	1.0	1.0	5.0
LMN1J	SMN1J	1.0	50	600	-	30	1.0	1.0	5.0
LMN1K	SMN1K	1.0	50	800	-	30	1.0	1.0	5.0
LMN1M	SMN1M	1.0	50	1000	-	30	1.0	1.0	5.0

1N4001G/GN1A Series, 1 A, Case Type: DO-41/SMA



1N4001G	GN1A	1.0	75	50	10	30	1.0	1.0	5.0
1N4002G	GN1B	1.0	75	100	10	30	1.0	1.0	5.0
1N4003G	GN1D	1.0	75	200	10	30	1.0	1.0	5.0
1N4004G	GN1G	1.0	75	400	10	30	1.0	1.0	5.0
1N4005G	GN1J	1.0	75	600	10	30	1.0	1.0	5.0
1N4006G	GN1K	1.0	75	800	10	30	1.0	1.0	5.0
1N4007G	GN1M	1.0	75	1000	10	30	1.0	1.0	5.0
BY133G	GN13	1.0	75	1300	10	30	1.0	1.0	5.0

GF1A Series, 1 A, Case Type: SMA



	GF1A	1.0	75	50	-	30	1.0	1.0	5.0
	GF1B	1.0	75	100	-	30	1.0	1.0	5.0
	GF1D	1.0	75	200	-	30	1.0	1.0	5.0
	GF1G	1.0	75	400	-	30	1.0	1.0	5.0
	GF1J	1.0	75	600	-	30	1.0	1.0	5.0
	GF1K	1.0	75	800	-	30	1.0	1.0	5.0
	GF1M	1.0	75	1000	-	30	1.0	1.0	5.0

DL4001 Series, 1 A, Case Type: MELF (Plastic)



	DL4001	1.0	75	50	-	30	1.1	1.0	5.0
	DL4002	1.0	75	100	-	30	1.1	1.0	5.0
	DL4003	1.0	75	200	-	30	1.1	1.0	5.0
	DL4004	1.0	75	400	-	30	1.1	1.0	5.0
	DL4005	1.0	75	600	-	30	1.1	1.0	5.0
	DL4006	1.0	75	800	-	30	1.1	1.0	5.0
	DL4007	1.0	75	1000	-	30	1.1	1.0	5.0



Glass Passivated Rectifier Diodes

The plastic material carries U/L recognition 94V-0.

Type No.		Max. Average Forward Rectified Current		Max. Repetitive Peak Reverse Voltage	Max. Repetitive Peak Forward Current	Max. Peak Forward Surge Current	Max. Forward Voltage Drop at Ta=25°C		Max. Reverse Current at Ta=25°C
		IF(AV)	@ Ta	VRRM	IFRM	IFSM	VF	@ IF	IR
Axial Lead	SMD	(A)	(°C)	(V)	(A)	(A)	(V)	(A)	(µA)

1N5391G/GNOA Series, 1.5 A, Case Type: DO-41/SMA



1N5391G	GNOA	1.5	75	50	-	50	1.1	1.5	5.0
1N5392G	GNOB	1.5	75	100	-	50	1.1	1.5	5.0
1N5393G	GNOB	1.5	75	200	-	50	1.1	1.5	5.0
1N5394G	GNOE	1.5	75	300	-	50	1.1	1.5	5.0
1N5395G	GNOG	1.5	75	400	-	50	1.1	1.5	5.0
1N5396G	GNOH	1.5	75	500	-	50	1.1	1.5	5.0
1N5397G	GNOJ	1.5	75	600	-	50	1.1	1.5	5.0
1N5398G	GNOK	1.5	75	800	-	50	1.1	1.5	5.0
1N5399G	GNOA	1.5	75	1000	-	50	1.1	1.5	5.0

DR200G/GN2A Series, 2 A, Case Type: D2/SMB



DR200G	GN2A	2.0	50	50	15	75	1.0	2.0	5.0
DR201G	GN2B	2.0	50	100	15	75	1.0	2.0	5.0
DR202G	GN2D	2.0	50	200	15	75	1.0	2.0	5.0
DR204G	GN2G	2.0	50	400	15	75	1.0	2.0	5.0
DR206G	GN2J	2.0	50	600	15	75	1.0	2.0	5.0
DR208G	GN2K	2.0	50	800	15	75	1.0	2.0	5.0
DR210G	GN2M	2.0	50	1000	15	75	1.0	2.0	5.0

GNTA Series, 2.5 A, Case Type: SMB



	GNTA	2.5	75	50	-	150	1.1	2.5	5.0
	GNTB	2.5	75	100	-	150	1.1	2.5	5.0
	GNTD	2.5	75	200	-	150	1.1	2.5	5.0
	GNTG	2.5	75	400	-	150	1.1	2.5	5.0
	GNTJ	2.5	75	600	-	150	1.1	2.5	5.0
	GNTK	2.5	75	800	-	150	1.1	2.5	5.0
	GNTM	2.5	75	1000	-	150	1.1	2.5	5.0

1N5400G/GN3A Series, 3 A, Case Type: DO-201AD/SMC



1N5400G	GN3A	3.0	75	50	20	150	1.0	3.0	5.0
1N5401G	GN3B	3.0	75	100	20	150	1.0	3.0	5.0
1N5402G	GN3D	3.0	75	200	20	150	1.0	3.0	5.0
1N5404G	GN3G	3.0	75	400	20	150	1.0	3.0	5.0
1N5406G	GN3J	3.0	75	600	20	150	1.0	3.0	5.0
1N5407G	GN3K	3.0	75	800	20	150	1.1	3.0	5.0
1N5408G	GN3M	3.0	75	1000	20	150	1.1	3.0	5.0

Contact your regional EIC Sales for other GPP Diodes and special specifications not displayed in this section



High Speed Switching Diodes

Type No.	Max. Average Forward Rectified Current		Max. Reverse Voltage	Max. Repetitive Peak Forward Current	Max. Repetitive Surge Current	Max. Forward Voltage Drop at Ta=25°C		Max. Reverse Current at Ta=25°C	Max. Reverse Recovery Time ⁽¹⁾	Max. Power Dissipation
	I _{F(AV)}	@ Ta	V _{RM}	I _{FRM}	I _{FSM}	V _F	@ I _F	I _R	T _{rr}	P _D
	(mA)	(°C)	(V)	(mA)	(A)	(V)	(mA)	(μA)	(ns)	(mW)

1N4148 Series, Case Type: DO-35



1N4148	150	25	75	450	0.5	1.0	10	5.0	4	500
1N4149	150	25	100	-	0.5	1.0	10	5.0 nA	4	500
1N4150	200	25	50	600	0.5	1.0	200	0.1	4	500
1N4151	200	25	75	450	0.5	1.0	50	0.05	4	500
1N4152	150	25	30	450	-	0.88	20	0.05	2	500
1N4153	150	25	50	450	-	0.88	20	0.05	2	500
1N4154	150	25	25	450	-	1.0	30	0.1	4	500

1N4448 Series, Case Type: DO-35



1N4447	150	25	75	450	-	1.0	20	5.0	4	500
1N4448	150	25	75	450	-	1.0	10	5.0	4	500
1N4449	150	25	75	450	-	1.0	30	5.0	4	500
1N4450	200	25	30	600	-	1.0	200	0.05	4	500
1N4454	150	25	75	450	-	1.0	10	5.0	4	500

1N4531 Series, Case Type: DO-34



1N4531	200	75	75	-	0.5	1.0	10	25 nA	4	500
1N4532	200	75	75	-	0.5	1.0	10	100 nA	2	500
1N4148S	150	25	75	450	0.5	1.0	10	5.0	4	500

1N914 Series, Case Type: DO-35



1N914	75	25	75	-	0.5	1.0	10	25 nA	4	250
1N914A	75	25	75	-	0.5	1.0	20	25 nA	4	250
1N914B	75	25	75	-	0.5	0.72	5	25 nA	4	250

1S1585 Series, Case Type: DO-35



1S1585	150	25	80	-	0.7	1.0	100	0.5	2	300
1S1586	150	25	50	-	0.7	1.0	100	0.5	2	300
1S1587	130	25	50	-	0.6	1.2	100	0.5	2	300
1S1588	120	25	30	-	0.5	1.3	100	0.5	4	300
1S2076A	150	25	70	-	1.0	0.8	10	0.1	4	250

1SS130 Series, Case Type: DO-34



1SS130	130	25	75	400	-	1.0	10	0.5	4	300
1SS131	130	25	80	400	0.6	1.2	100	0.5	4	300
1SS132	120	25	50	350	0.5	1.2	100	0.5	4	300
1SS133	110	25	35	300	0.6	1.2	100	0.5	4	300

Note : (1) Reverse Recovery test conditions : I_F = 1A, di/dt = 50 A/ms



High Speed Switching Diodes

Type No.	Max. Average Forward Rectified Current		Max. Reverse Voltage	Max. Repetitive Peak Forward Current	Max. Repetitive Surge Current	Max. Forward Voltage Drop at Ta=25°C		Max. Reverse Current at Ta=25°C	Max. Reverse Recovery Time ⁽¹⁾	Max. Power Dissipation
	I _{F(AV)}	@ Ta	V _{RM}	I _{FRM}	I _{FSM}	V _F	@ I _F	I _R	T _{rr}	P _D
	(mA)	(°C)	(V)	(mA)	(A)	(V)	(mA)	(μA)	(ns)	(mW)

1SS176 Series, Case Type: DO-34



1SS176	100	25	30	300	1.0	1.2	100	0.5	4.0	300
1SS177	100	25	50	300	1.0	1.2	100	0.5	4.0	300
1SS178	100	25	80	300	1.0	1.2	100	0.5	4.0	300
1SS270A	150	25	70	-	1.0	0.8	10	1.0	3.5	250
BAS15	100	150	50	225	0.5	1.1	100	0.2	4.0	350

BAV10 Series, Case Type: DO-35



BAV10	300	25	60	600	1.0	1.0	200	0.1	6	350
BAV19	200	25	100	625	1.0	1.0	100	0.1	50	500
BAV20	200	25	150	625	1.0	1.0	100	0.1	50	500
BAV21	200	25	200	625	1.0	1.0	100	0.1	50	500

BAW62 Series, Case Type: DO-35



BAW62	250	25	75	450	0.5	1.0	100	5.0	4	350
BAW75	150	25	25	-	2.0	1.0	30	0.1	4	500
BAW76	150	25	50	-	2.0	1.0	100	0.1	4	500

BAV100 Series, Case Type: MiniMELF



BAV100	200	25	50	625	1.0	1.0	100	0.1	50	400
BAV101	200	25	100	625	1.0	1.0	100	0.1	50	400
BAV102	200	25	150	625	1.0	1.0	100	0.1	50	400
BAV103	200	25	200	625	1.0	1.0	100	0.1	50	400
BAV105	300	25	60	600	0.5	1.0	200	0.1	6	500

BAX14 Series, Case Type: DO-35



BAX14	400	25	40	2A	9.0	1.00	300	0.1	50	450
BAX18	400	25	75	2A	9.0	1.00	300	5.0	50	450
BAY80	200	25	150	650	1.0	1.07	150	0.1	50	400

LL4148 Series, Case Type: MiniMELF



LL4148	200	25	75	450	0.5	1.00	10	5.00	4	500
LL4150	200	25	50	600	0.5	1.00	200	0.10	4	500
LL4151	200	25	50	450	0.5	1.00	50	0.05	4	500
LL4153	200	25	50	450	0.5	0.88	50	0.05	4	500
LL4448	200	25	75	450	0.5	1.00	100	5.00	4	500

MUR3020PT Series, Case Type: TO-247AD (TO-3P)



MUR3020PT	30 A	150 Tc	200	-	200	1.05	15	10	30 ⁽¹⁾	-
MUR3040PT	30 A	150 Tc	400	-	150	1.25	15	10	60 ⁽¹⁾	-

Note : (1) Reverse Recovery test conditions : I_F = 1A, di/dt = 50 A/ms



High Speed Switching Diodes

Type No.	Max. Average Forward Rectified Current		Max. Reverse Voltage	Max. Repetitive Peak Forward Current	Max. Repetitive Surge Current	Max. Forward Voltage Drop at Ta=25°C		Max. Reverse Current at Ta=25°C	Max. Reverse Recovery Time ⁽¹⁾	Max. Power Dissipation
	I _{F(AV)}	@ Ta	V _{RM}	I _{FRM}	I _{FSM}	V _F	@ I _F	I _R	T _{rr}	P _D
	(mA)	(°C)	(V)	(mA)	(A)	(V)	(mA)	(μA)	(ns)	(mW)

1N4148W Series, Case Type: SOD-123, SOD-323, SOD-523



1N4148W	150	25	100	-	0.50	1.0	10	5.0	4.0	400
1N4148WS	150	25	75	-	0.35	1.0	10	5.0	4.0	200
1N4148WT	125	25	100	-	2.00	1.0	50	1.0	4.0	150

MMSD4148, Case Type: SOD-123



MMSD4148	200	25	100	-	0.5	1.0	10	5.0	4.0	425
----------	-----	----	-----	---	-----	-----	----	-----	-----	-----

1SS355 Series, Case Type: SOD-323



1SS355	100	25	90	-	0.5	1.2	100	0.1	4.0	-
--------	-----	----	----	---	-----	-----	-----	-----	-----	---

BAS16WS, Case Type: SOD-323



BAS16WS	250	25	75	-	0.5	1.0	50	1.0	6.0	200
---------	-----	----	----	---	-----	-----	----	-----	-----	-----

BAV19WS Series, Case Type: SOD-323



BAV19WS	200	25	100	625	1.0	1.0	100	0.1	50	200
BAV20WS	200	25	150	625	1.0	1.0	100	0.1	50	200
BAV21WS	200	25	200	625	1.0	1.0	100	0.1	50	200

BAS316, Case Type: SOD-323



BAS316	250	90	100	-	4.0	1.25	150	1.0	4.0	400
BAS321	250	25	250	-	9.0	1.25	200	0.1	4.0	300

BAS516, Case Type: SOD-523



BAS516	250	90	85	-	4.0	1.25	150	1.0	4.0	500
BAS521	250	90	300	-	4.5	1.10	100	0.2	50	500

1SS181-4 Series, Case Type: SOT-23



1SS181	100	25	85	-	2.0	1.2	100	0.5	4.0	150
1SS184	100	25	85	-	2.0	1.2	100	0.5	4.0	150
1SS187	100	25	85	-	2.0	1.2	100	0.5	4.0	150

1SS226 Series, Case Type: SOT-23



1SS226	100	25	85	-	2.0	1.2	100	0.5	4.0	150
--------	-----	----	----	---	-----	-----	-----	-----	-----	-----



High Speed Switching Diodes

Type No.	Max. Average Forward Rectified Current		Max. Reverse Voltage	Max. Repetitive Peak Forward Current	Max. Repetitive Surge Current	Max. Forward Voltage Drop at Ta=25°C		Max. Reverse Current at Ta=25°C	Max. Reverse Recovery Time ⁽¹⁾	Max. Power Dissipation
	I _{F(AV)}	@ Ta	V _{RM}	I _{FRM}	I _{FSM}	V _F	@ I _F	I _R	T _{rr}	P _D
	(mA)	(°C)	(V)	(mA)	(A)	(V)	(mA)	(μA)	(ns)	(mW)

BAS16, Case Type: SOT-23



BAS16	215	25	85	500	4	1.25	150	1.0	4.0	250
BAS116	215	25	85	500	4	1.25	150	5(nA)	3(μs)	250

BAS19 - 21, Case Type: SOT-23



BAS19	200	25	120	-	9	1.0	100	0.1	50	250
BAS20	200	25	200	-	9	1.0	100	0.1	50	250
BAS21	200	25	250	-	9	1.0	100	0.1	50	250

BAS70 Series, Case Type: SOT-23



BAS70-00	200	25	70	-	0.6	1.0	15	0.1	5.0	200
BAS70-04	200	25	70	-	0.6	1.0	15	0.1	5.0	200
BAS70-05	200	25	70	-	0.6	1.0	15	0.1	5.0	200
BAS70-06	200	25	70	-	0.6	1.0	15	0.1	5.0	200

BAV23 Series, Case Type: SOT-23



BAV23	400	25	250	625	9.0	1.0	100	0.1	50	350
BAV23SE	400	25	250	625	9.0	1.0	100	0.1	50	350
BAV23CC	400	25	250	625	9.0	1.0	100	0.1	50	350
BAV23CA	400	25	250	625	9.0	1.0	100	0.1	50	350

BAV70 & BAV99, Case Type: SOT-23



BAV70	200	25	70	-	2	1.0	50	5.0	6.0	350
BAV99	125	25	85	450	1	1.0	50	1.0	4.0	250

BAW56, Case Type: SOT-23



BAW56	125	25	85	450	4	1.25	150	1.0	4.0	250
-------	-----	----	----	-----	---	------	-----	-----	-----	-----

MMBD914, Case Type: SOT-23



MMBD914	200	25	100	-	0.5	1.0	10	5.0	4.0	225
---------	-----	----	-----	---	-----	-----	----	-----	-----	-----

MMBD4148, Case Type: SOT-23



MMBD4148	200	25	100	700	1.0	1.0	10	5.0	4.0	350
MMBD4148SE	200	25	100	700	1.0	1.0	10	5.0	4.0	350
MMBD4148CC	200	25	100	700	1.0	1.0	10	5.0	4.0	350
MMBD4148CA	200	25	100	700	1.0	1.0	10	5.0	4.0	350

High Voltage Rectifier Diodes

The plastic material carries U/L recognition 94V-O.

Type No.		Max. Average Forward Rectified Current		Max. Repetitive Peak Reverse Voltage	Max. Repetitive Peak Forward Current	Max. Peak Forward Surge Current	Max. Forward Voltage Drop at Ta=25°C		Max. Reverse Current at Ta=25°C
		I _{F(AV)}	@ Ta	V _{RRM}	I _{FRM}	I _{FSM}	V _F	@ I _F	I _R
Axial Lead	SMD	(A)	(°C)	(V)	(A)	(A)	(V)	(A)	(μA)

HVR125 Series, 0.2 - 0.5 A, Case Type: DO-41



HVR125		0.5	50	2500	5.0	30	3.3	1.0	5.0
HVR130		0.5	50	3000	5.0	30	3.3	1.0	5.0
HVR140		0.3	50	4000	5.0	30	5.0	1.0	5.0
HVR150		0.3	50	5000	5.0	30	5.0	1.0	5.0
HVR160		0.2	50	6000	5.0	30	8.0	1.0	5.0
HVR170		0.2	50	7000	5.0	30	8.0	1.0	5.0
HVR180		0.2	50	8000	5.0	30	8.0	1.0	5.0

GP02-20 Series, 0.25 A, Case Type: DO-41



GP02-20		0.25	55	2000	-	15	3.0	1.0	5.0
GP02-25		0.25	55	2500	-	15	3.0	1.0	5.0
GP02-30		0.25	55	3000	-	15	3.0	1.0	5.0
GP02-35		0.25	55	3500	-	15	3.0	1.0	5.0
GP02-40		0.25	55	4000	-	15	3.0	1.0	5.0

HVR230 Series, 0.5 - 1 A, Case Type: D2



HVR230		1.0	50	3000	-	50	3.0	1.0	5.0
HVR250		0.5	50	5000	-	50	5.0	1.0	5.0

HVR112/SN1N Series, 1 A, Case Type: DO-41/SMA



HVR112	SN1N	1.0	75	1200	5.0	30	2.2	1.0	5.0
HVR114	SN1O	1.0	75	1400	5.0	30	2.2	1.0	5.0
HVR116	SN1P	1.0	75	1600	5.0	30	2.2	1.0	5.0
HVR118	SN1Q	1.0	75	1800	5.0	30	2.2	1.0	5.0
HVR120	SN1R	1.0	75	2000	5.0	30	2.2	1.0	5.0

S1T Series, 1.0 A, Case Type: SMA



	S1T	1.0	75	3000	-	30	3.0	1.0	5.0
--	-----	-----	----	------	---	----	-----	-----	-----

SHV-01JN & SHV-05J Series, 30 mA, Case Type: M1A & DO-41



SHV-01JN		30 mA	25	500	-	3	1.0	10	10
SHV-05J		30 mA	25	2500	-	3	5.0	10	10



High Voltage Rectifier Diodes

The plastic material carries U/L recognition 94V-0.

Type No.		Max. Average Forward Rectified Current		Max. Repetitive Peak Reverse Voltage	Max. Repetitive Peak Forward Current	Max. Peak Forward Surge Current	Max. Forward Voltage Drop at Ta=25°C		Max. Reverse Current at Ta=25°C
		I _{F(AV)}	@ Ta	V _{RRM}	I _{FRM}	I _{FSM}	V _F	@ I _F	I _R
Axial Lead	SMD	(A)	(°C)	(V)	(A)	(A)	(V)	(A)	(μA)

SHV-02 - SHV-06HN Series, 2 mA, Case Type: DO-41



SHV-02		2 mA	100 (Tc)	2000	-	0.3	16	10	1.0
SHV-04		2 mA	25	4000	-	0.5	20	10	1.0
SHV-06HK		2 mA	25	6000	-	0.5	24	10	1.0

HVR312/SN3N Series, 3 A, Case Type: DO-201AD/SMC



HVR312	SN3N	3.0	50	1200	10	100	2.2	3.0	10
HVR314	SN3O	3.0	50	1400	10	100	2.2	3.0	10
HVR316	SN3P	3.0	50	1600	10	100	2.2	3.0	10
HVR318	SN3Q	3.0	50	1800	10	100	2.2	3.0	10
HVR320	SN3R	3.0	50	2000	10	100	2.2	3.0	10

HVR512/SN5N Series, 5 A, Case Type: DO-201AD/SMC



HVR512	SN5N	5.0	50	1200	20	200	2.2	5.0	10
HVR514	SN5O	5.0	50	1400	20	200	2.2	5.0	10
HVR516	SN5P	5.0	50	1600	20	200	2.2	5.0	10
HVR518	SN5Q	5.0	50	1800	20	200	2.2	5.0	10
HVR520	SN5R	5.0	50	2000	20	200	2.2	5.0	10

Note:

V_{RRM} > 2000 V is available on special request



High Voltage Fast Recovery Rectifier Diodes

The plastic material carries U/L recognition 94V-0.

Type No.	Max. Average Forward Rectified Current		Max. Repetitive Peak Reverse Voltage	Max. Repetitive Peak Forward Current	Max. Peak Forward Surge Current	Max. Forward Voltage Drop at Ta=25°C		Max. Reverse Current at Ta=25°C	Max. Reverse Recovery Time ⁽¹⁾
	I _{F(AV)} @ Ta		V _{RRM}	I _{FRM}	I _{FSM}	V _F @ I _F		I _R	T _{rr}
	(A)	(°C)	(V)	(A)	(A)	(V)	(A)	(μA)	(ns)

BY8004 Series, Case Type: DO-41



BY8004	0.02	90	5000	0.5	-	20	0.1	3.0 *	100
BY8006	0.01	100	8000	0.5	-	25	0.1	3.0 *	100

* T_j=120°C

HFR125 Series, 0.25 - 0.30 A, Case Type: DO-41



HFR125	0.25	50	2500	-	30	5.0	0.25	1.0	250
HFR130	0.25	50	3000	-	30	7.0	0.25	1.0	200
HFR180	0.30	50	8000	-	40	9.0	0.3	5.0	200

GS1S, 0.2 A, Case Type: SMA



GS1S	0.2	25	2500	-	30	6.0	0.2	1.0	35
------	-----	----	------	---	----	-----	-----	-----	----

RGP02 Series, 0.5 A, Case Type: DO-41



RGP02-12E	0.5	55	1200	5.0	20	1.8	0.1	5.0	300
RGP02-14E	0.5	55	1400	5.0	20	1.8	0.1	5.0	300
RGP02-16E	0.5	55	1600	5.0	20	1.8	0.1	5.0	300
RGP02-18E	0.5	55	1800	5.0	20	1.8	0.1	5.0	300
RGP02-20E	0.5	55	2000	5.0	20	1.8	0.1	5.0	300

SR1P Series, 0.5 A, Case Type: SMA



SR1P	0.5	75	1600	-	20	1.5	1.0	10	500
SR1R	0.5	75	2000	-	30	3.0	0.5	5.0	100

GR15 Series, 1 A, Case Type: DO-215AC



GR15-G	0.5	55	1500	-	20	2.0	0.1	5.0	300
GR20-G	0.5	55	2000	-	20	2.4	0.1	5.0	500

3TH41 Series, 3 A, Case Type: DO-201AD



3TH41	3.0	25	1500	-	50	1.2	3.0	10	1.5μs ⁽²⁾
-------	-----	----	------	---	----	-----	-----	----	----------------------

Notes :

(1) Reverse Recovery test conditions : I_F = 0.5A, I_R = 1 A, I_{rr} = 0.25 A

(2) Reverse Recovery test conditions : I_F = 100 mA, I_R = 100 mA



Cell Rectifier Diodes

The plastic material carries U/L recognition 94V-O.

Type No.	Max. Average Forward Rectified Current		Max. Repetitive Peak Reverse Voltage	Max. Repetitive Peak Forward Current	Max. Peak Forward Surge Current	Max. Forward Voltage Drop at Ta=25°C		Max. Reverse Current at Ta=25°C
	$I_{F(AV)}$	@ Ta	V_{RRM}	I_{FRM}	I_{FSM}	V_F	@ I_F	I_R
	(A)	(°C)	(V)	(A)	(A)	(V)	(A)	(μ A)

CN3 Series, 3 A, Case Type: C3A



CN3A	3.0	75	50	30	200	1.1	3.0	5.0
CN3B	3.0	75	100	30	200	1.1	3.0	5.0
CN3D	3.0	75	200	30	200	1.1	3.0	5.0
CN3G	3.0	75	400	30	200	1.1	3.0	5.0
CN3J	3.0	75	600	30	200	1.1	3.0	5.0
CN3K	3.0	75	800	30	200	1.1	3.0	5.0
CN3M	3.0	75	1000	30	200	1.1	3.0	5.0

CN5 Series, 5 A, Case Type: C5A



CN5A	5.0	75	50	60	250	1.1	5.0	5.0
CN5B	5.0	75	100	60	250	1.1	5.0	5.0
CN5D	5.0	75	200	60	250	1.1	5.0	5.0
CN5G	5.0	75	400	60	250	1.1	5.0	5.0
CN5J	5.0	75	600	60	250	1.1	5.0	5.0
CN5K	5.0	75	800	60	250	1.1	5.0	5.0
CN5M	5.0	75	1000	60	250	1.1	5.0	5.0

CN8 Series, 8 A, Case Type: C8A



CN8A	8.0	75	50	60	300	1.1	8.0	5.0
CN8B	8.0	75	100	60	300	1.1	8.0	5.0
CN8D	8.0	75	200	60	300	1.1	8.0	5.0
CN8G	8.0	75	400	60	300	1.1	8.0	5.0
CN8J	8.0	75	600	60	300	1.1	8.0	5.0
CN8K	8.0	75	800	60	300	1.1	8.0	5.0
CN8M	8.0	75	1000	60	300	1.1	8.0	5.0

CN18 Series, 18 A, Case Type: C18A



CN18A	18	75	50	75	400	1.1	18	5.0
CN18B	18	75	100	75	400	1.1	18	5.0
CN18D	18	75	200	75	400	1.1	18	5.0
CN18G	18	75	400	75	400	1.1	18	5.0
CN18J	18	75	600	75	400	1.1	18	5.0
CN18K	18	75	800	75	400	1.1	18	5.0
CN18M	18	75	1000	75	400	1.1	18	5.0

CN25 Series, 25 A, Case Type: C18A



CN25A	25	75	50	75	400	1.1	25	5.0
CN25B	25	75	100	75	400	1.1	25	5.0
CN25D	25	75	200	75	400	1.1	25	5.0
CN25G	25	75	400	75	400	1.1	25	5.0
CN25J	25	75	600	75	400	1.1	25	5.0
CN25K	25	75	800	75	400	1.1	25	5.0
CN25M	25	75	1000	75	400	1.1	25	5.0



Automotive Rectifier Diodes

The plastic material carries U/L recognition 94V-0.

Type No.	Max. Average Forward Rectified Current		Max. Repetitive Peak Reverse Voltage	Max. Repetitive Peak Forward Current	Max. Peak Forward Surge Current	Max. Forward Voltage Drop at Ta=25°C		Max. Reverse Current at Ta=25°C
	I _{F(AV)}	@ Ta	V _{RRM}	I _{FRM}	I _{FSM}	V _F	@ I _F	I _R
	(A)	(°C)	(V)	(A)	(A)	(V)	(A)	(μA)

AR2500/MR2500 Series, 25 A, Case Type: BUTTON/MR



AR2500 ⁽¹⁾	MR2500 ⁽¹⁾	25	150	50	75	400	1.0	25	5.0
AR2501 ⁽¹⁾	MR2501 ⁽¹⁾	25	150	100	75	400	1.0	25	5.0
AR2502 ⁽¹⁾	MR2502 ⁽¹⁾	25	150	200	75	400	1.0	25	5.0
AR2504 ⁽¹⁾	MR2504 ⁽¹⁾	25	150	400	75	400	1.0	25	5.0
AR2506 ⁽¹⁾	MR2506 ⁽¹⁾	25	150	600	75	400	1.0	25	5.0
AR2508 ⁽¹⁾	MR2508 ⁽¹⁾	25	150	800	75	400	1.0	25	5.0
AR2510 ⁽¹⁾	MR2510 ⁽¹⁾	25	150	1000	75	400	1.0	25	5.0
AR2512 ⁽¹⁾	MR2512 ⁽¹⁾	25	150	1200	75	400	1.0	25	5.0

AR3500/MR3500 Series, 35 A, Case Type: BUTTON/MR



AR3500 ⁽¹⁾	MR3500 ⁽¹⁾	35	150	50	75	400	1.1	35	5.0
AR3501 ⁽¹⁾	MR3501 ⁽¹⁾	35	150	100	75	400	1.1	35	5.0
AR3502 ⁽¹⁾	MR3502 ⁽¹⁾	35	150	200	75	400	1.1	35	5.0
AR3504 ⁽¹⁾	MR3504 ⁽¹⁾	35	150	400	75	400	1.1	35	5.0
AR3506 ⁽¹⁾	MR3506 ⁽¹⁾	35	150	600	75	400	1.1	35	5.0
AR3508 ⁽¹⁾	MR3508 ⁽¹⁾	35	150	800	75	400	1.1	35	5.0
AR3510 ⁽¹⁾	MR3510 ⁽¹⁾	35	150	1000	75	400	1.1	35	5.0
AR3512 ⁽¹⁾	MR3512 ⁽¹⁾	35	150	1200	75	400	1.1	35	5.0

AR5000/MR5000 Series, 50 A, Case Type: BUTTON/MR

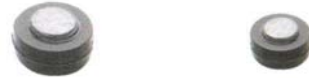

AR5000 ⁽¹⁾	MR5000 ⁽¹⁾	50	150	50	75	500	1.1	50	5.0
AR5001 ⁽¹⁾	MR5001 ⁽¹⁾	50	150	100	75	500	1.1	50	5.0
AR5002 ⁽¹⁾	MR5002 ⁽¹⁾	50	150	200	75	500	1.1	50	5.0
AR5004 ⁽¹⁾	MR5004 ⁽¹⁾	50	150	400	75	500	1.1	50	5.0
AR5006 ⁽¹⁾	MR5006 ⁽¹⁾	50	150	600	75	500	1.1	50	5.0
AR5008 ⁽¹⁾	MR5008 ⁽¹⁾	50	150	800	75	500	1.1	50	5.0
AR5010 ⁽¹⁾	MR5010 ⁽¹⁾	50	150	1000	75	500	1.1	50	5.0
AR5012 ⁽¹⁾	MR5012 ⁽¹⁾	50	150	1200	75	500	1.1	50	5.0

MR750 Series, 22 A, Case Type: D6



MR750		22	60 (T _L)	50	-	400	0.9	6.0	25
MR751		22	60 (T _L)	100	-	400	0.9	6.0	25
MR752		22	60 (T _L)	200	-	400	0.9	6.0	25
MR754		22	60 (T _L)	400	-	400	0.9	6.0	25
MR756		22	60 (T _L)	600	-	400	0.9	6.0	25
MR758		22	60 (T _L)	800	-	400	0.9	6.0	25
MR760		22	60 (T _L)	1000	-	400	0.9	6.0	25

Note:

(1) Wire leads version available in case type D6 ; Add suffix "L" e.g. AR2500L



Avalanche Rectifier Diodes

The plastic material carries U/L recognition 94V-O.

Type No.	Max. Allowable Avalanche Current (Note 1)	Max. Repetitive Peak Reverse Voltage	Min. Avalanche Breakdown Voltage @ 1 mA	Max. Avalanche Breakdown Voltage @ 1 mA	Max. Peak Forward Surge Current	Max. Reverse Current at Ta=25°C
	I _{ZSM}	V _{RRM}	V _{BR} (Min)	V _{BR} (Max)	I _{FSM}	I _R
	(A)	(V)	(V)	(V)	(A)	(μA)

R2G Series, 1 A, Case Type: D2



R2G	1.0	115	120	145	-	10
R2M	1.0	130	135	180	75	5.0
R2KN	1.0	140	150	170	-	10
R2KS	1.0	145	160	180	-	10
R2K	1.0	150	170	200	-	10

BYD13D Series, 1.4 A, Case Type: DO-41



BYD13D	1.4	200	225	-	20	1.0
BYD13G	1.4	400	450	-	20	1.0
BYD13J	1.4	600	650	-	20	1.0
BYD13K	1.4	800	900	-	20	1.0
BYD13M	1.4	1000	1100	-	20	1.0

BYD17D Series, 1.5 A, Case Type: MELF(Pastic)



BYD17D	1.5	225	20	1.05	1.0	1.0
BYD17G	1.5	450	20	1.05	1.0	1.0
BYD17J	1.5	650	20	1.05	1.0	1.0
BYD17K	1.5	900	20	1.05	1.0	1.0
BYD17M	1.5	1100	20	1.05	1.0	1.0

BYW54 Series, 2.0 A, Case Type: D2



BYW54	2.0	600	650	-	50	1.0
BYW55	2.0	800	900	-	50	1.0
BYW56	2.0	1000	1100	-	50	1.0

R2KY Series, 2.0 - 3.0 A, Case Type: D2



R2KY	2.0	120	130	155	-	10
RM25	3.0	40	50	61.5	-	5.0

BYX134PL Series, 0.05 A, Case Type: D2



BYX134PL	0.05	4000	5500	7500	-	1.0
----------	------	------	------	------	---	-----

* For case type DO-41 ; Add suffix "G" e.g. BYX134GPL

Note : (1) 100 μs single square pulse



Avalanche Fast Recovery Rectifier Diodes

The plastic material carries U/L recognition 94V-O.

Type No.	Max. Average Forward Rectified Current		Max. Repetitive Peak Reverse Voltage	Min. Avalanche Breakdown Voltage @ 100 μ A	Max. Peak Forward Surge Current	Max. Forward Voltage Drop at Ta=25°C		Max. Reverse Current at Ta=25°C	Max. Reverse Recovery Time
	$I_{F(AV)}$	@ Ttp	V_{RRM}	$V_{BR(Min)}$	I_{FSM}	V_F @ I_F		I_R	$T_{rr}^{(1)}$
	(A)	(°C)	(V)	(V)	(A)	(V)	(A)	(mA)	(ns)

BAX12 Series, 0.4 A, Case Type: M1A



BAX12	0.4	25	90	120	15	1.25	0.4	0.1	50
BAX12A	0.4	25	90	120	15	1.25	0.4	0.1	50

BYV26A Series, 1 A, Case Type: DO-41



BYV26A	1.0	55	200	300	30	2.5	1.0	5.0	30
BYV26B	1.0	55	400	500	30	2.5	1.0	5.0	30
BYV26C	1.0	55	600	700	30	2.5	1.0	5.0	30
BYV26D	1.0	55	800	900	30	2.5	1.0	5.0	75
BYV26E	1.0	55	1000	1100	30	2.5	1.0	5.0	75

BYD33D Series, 1.3 A, Case Type: DO-41



BYD33D	1.3	55	200	300	20	1.3	1.0	1.0	250
BYD33G	1.3	55	400	500	20	1.3	1.0	1.0	250
BYD33J	1.3	55	600	700	20	1.3	1.0	1.0	250
BYD33K	1.3	55	800	900	20	1.3	1.0	1.0	300
BYD33M	1.3	55	1000	1100	20	1.3	1.0	1.0	300

BYV36 Series, 1.5 - 1.6 A, Case Type: D2



BYV36A	1.6	60	200	300	30	1.35	1.0	5.0	100
BYV36B	1.6	60	400	500	30	1.35	1.0	5.0	100
BYV36C	1.6	60	600	700	30	1.35	1.0	5.0	100
BYV36D	1.5	60	800	900	30	1.45	1.0	5.0	150
BYV36E	1.5	60	1000	1100	30	1.45	1.0	5.0	150

BYV95 Series, 1.5 A, Case Type: D2



BYV95A	1.5	55	200	300	35	1.6	3.0	5.0	250
BYV95B	1.5	55	400	500	35	1.6	3.0	5.0	250
BYV95C	1.5	55	600	700	35	1.6	3.0	5.0	250
BYV96D	1.5	55	800	900	35	1.6	3.0	5.0	300
BYV96E	1.5	55	1000	1100	35	1.6	3.0	5.0	300

BYG10D - M Series, 1.5 A, Case Type: SMA



BYG10D	1.5	85	200	-	30	1.15	1.5	1.0	4 μ s
BYG10G	1.5	85	400	-	30	1.15	1.5	1.0	4 μ s
BYG10J	1.5	85	600	-	30	1.15	1.5	1.0	4 μ s
BYG10K	1.5	85	800	-	30	1.15	1.5	1.0	4 μ s
BYG10M	1.5	85	1000	-	30	1.15	1.5	1.0	4 μ s

Note : (1) Reverse Recovery test conditions : $I_F = 0.5A$, $I_R = 1 A$, $I_{rr} = 0.25 A$



Avalanche Fast Recovery Rectifier Diodes

The plastic material carries U/L recognition 94V-O.

Type No.	Max. Average Forward Rectified Current		Max. Repetitive Peak Reverse Voltage	Min. Avalanche Breakdown Voltage @ 100 μ A	Max. Peak Forward Surge Current	Max. Forward Voltage Drop at Ta=25°C		Max. Reverse Current at Ta=25°C	Max. Reverse Recovery Time
	I _{F(AV)}	@ T _{tp}	V _{RRM}	V _{BR(Min)}	I _{FSM}	V _F @ I _F		I _R	T _{rr} ⁽¹⁾
	(A)	(°C)	(V)	(V)	(A)	(V)	(A)	(mA)	(ns)

BYG20D - J Series, 1.5 A, Case Type: SMA



BYG20D	1.5	85	200	-	30	1.4	1.5	1.0	75
BYG20G	1.5	85	400	-	30	1.4	1.5	1.0	75
BYG20J	1.5	85	600	-	30	1.4	1.5	1.0	75

BYG24D - J Series, 1.5 A, Case Type: SMA



BYG24D	1.5	95	200	-	30	1.25	1.5	1.0	140
BYG24G	1.5	95	400	-	30	1.25	1.5	1.0	140
BYG24J	1.5	95	600	-	30	1.25	1.5	1.0	140

BYD37D - M Series, 1.5 A, Case Type: MELF(Pastic)



BYD37D	1.5	105(Ttp)	200	300	20	1.3	1.0	1.0	250
BYD37G	1.5	105(Ttp)	400	500	20	1.3	1.0	1.0	250
BYD37J	1.5	105(Ttp)	600	700	20	1.3	1.0	1.0	250
BYD37K	1.5	105(Ttp)	800	900	20	1.3	1.0	1.0	300
BYD37M	1.5	105(Ttp)	1000	1100	20	1.3	1.0	1.0	300

BYD37DA - MA Series, 1.5 A, Case Type: SMA



BYD37DA	1.5	105(Ttp)	200	300	20	1.3	1.0	1.0	250
BYD37GA	1.5	105(Ttp)	400	500	20	1.3	1.0	1.0	250
BYD37JA	1.5	105(Ttp)	600	700	20	1.3	1.0	1.0	250
BYD37KA	1.5	105(Ttp)	800	900	20	1.3	1.0	1.0	300
BYD37MA	1.5	105(Ttp)	1000	1100	20	1.3	1.0	1.0	300

BYD57D - V Series, 1.0-1.2 A, Case Type: MELF(Pastic)



BYD57D	1.0	85(Ttp)	200	300	5	3.6	1.0	5.0	30
BYD57G	1.0	85(Ttp)	400	500	5	3.6	1.0	5.0	30
BYD57J	1.0	85(Ttp)	600	700	5	3.6	1.0	5.0	30
BYD57K	1.0	85(Ttp)	800	900	5	3.6	1.0	5.0	75
BYD57M	1.0	85(Ttp)	1000	1100	5	3.6	1.0	5.0	75
BYD57U	1.2	85(Ttp)	1200	1300	5	2.3	1.0	5.0	150
BYD57V	1.2	85(Ttp)	1400	1500	5	2.3	1.0	5.0	150

Note : (1) Reverse Recovery test conditions : I_F = 0.5A, I_R = 1 A, I_{rr} = 0.25 A



Avalanche Fast Recovery Rectifier Diodes

The plastic material carries U/L recognition 94V-0.

Type No.	Max. Average Forward Rectified Current		Max. Repetitive Peak Reverse Voltage	Min. Avalanche Breakdown Voltage @ 100 μ A	Max. Peak Forward Surge Current	Max. Forward Voltage Drop at Ta=25°C		Max. Reverse Current at Ta=25°C	Max. Reverse Recovery Time
	I _{F(AV)}	@ T _{tp}	V _{RRM}	V _{BR(Min)}	I _{FSM}	V _F	@ I _F	I _R	T _{rr} ⁽¹⁾
	(A)	(°C)	(V)	(V)	(A)	(V)	(A)	(mA)	(ns)

BYD77D - V Series, 1.85 - 2 A, Case Type: MELF(Pastic)



BYD77A	2.0	105(Ttp)	50	55	25	0.98	1.0	1.0	25
BYD77B	2.0	105(Ttp)	100	110	25	0.98	1.0	1.0	25
BYD77C	2.0	105(Ttp)	150	165	25	0.98	1.0	1.0	25
BYD77D	2.0	105(Ttp)	200	220	25	0.98	1.0	1.0	25
BYD77E	1.85	105(Ttp)	250	275	25	1.05	1.0	1.0	50
BYD77F	1.85	105(Ttp)	300	330	25	1.05	1.0	1.0	50
BYD77G	1.85	105(Ttp)	400	440	25	1.05	1.0	1.0	50

BYV27 Series, 2 A, Case Type: DO-41



BYV27-100	2.0	85	100	110	50	1.07	3.0	1.0	25
BYV27-150	2.0	85	150	165	50	1.07	3.0	1.0	25
BYV27-200	2.0	85	200	220	50	1.07	3.0	1.0	25

BYW95 Series, 3.0 A, Case Type: DO-201AD



BYW95A	3.0	55	200	300	70	1.5	5.0	5.0	250
BYW95B	3.0	55	400	500	70	1.5	5.0	5.0	250
BYW95C	3.0	55	600	700	70	1.5	5.0	5.0	250
BYW96D	3.0	55	800	900	70	1.5	5.0	5.0	300
BYW96E	3.0	55	1000	1100	70	1.5	5.0	5.0	300

Note :

(1) Reverse Recovery test conditions : I_F = 0.5A, I_R = 1 A, I_{rr} = 0.25 A

Fast Recovery Rectifier Diodes

The plastic material carries U/L recognition 94V-0.

Type No.	Max. Average Forward Rectified Current	Max. Repetitive Peak Reverse Voltage	Max. Repetitive Peak Forward Current	Max. Surge Forward Current	Max. Forward Voltage Drop at Ta=25°C	Max. Reverse Current at Ta=25°C	Max. Reverse Recovery Time	
								I _{F(AV)} @ Ta
Axial Lead	SMD	(A) (°C)	(V)	(A)	(A)	(V) (A)	(μA)	(ns)

1F1 Series, 1 A, Case Type: R-1



1F1		1.0	50	50	-	30	1.3	1.0	5.0	150 ⁽¹⁾
1F2		1.0	50	100	-	30	1.3	1.0	5.0	150 ⁽¹⁾
1F3		1.0	50	200	-	30	1.3	1.0	5.0	150 ⁽¹⁾
1F4		1.0	50	400	-	30	1.3	1.0	5.0	150 ⁽¹⁾
1F5		1.0	50	600	-	30	1.3	1.0	5.0	250 ⁽¹⁾
1F6		1.0	50	800	-	30	1.3	1.0	5.0	500 ⁽¹⁾
1F7		1.0	50	1000	-	30	1.3	1.0	5.0	500 ⁽¹⁾

ERA34-10/EP01C 0.1 - 0.2 A, Case Type: DO-41



ERA34-10		0.10	60	1000	-	2.0	3.0	0.1	50	150 ⁽³⁾
EP01C		0.20	25	1000	-	5.0	4.0	0.2	5.0	200 ⁽³⁾
AP01C		0.20	25	1000	-	5.0	4.0	0.2	100	200 ⁽³⁾

EU1 Series, 0.2 - 0.25 A, Case Type: DO-41



EU1Z		0.25	25	200	-	15	2.5	0.25	10	400 ⁽²⁾
EU1		0.25	25	400	-	15	2.5	0.25	10	400 ⁽²⁾
EU1A		0.25	25	600	-	15	2.5	0.25	10	400 ⁽²⁾
EU1C		0.20	25	1000	-	15	2.5	0.20	10	400 ⁽²⁾

RU1 Series, 0.2 - 0.25 A, Case Type: D2



RU1		0.25	50	400	-	15	2.5	0.25	10	400 ⁽²⁾
RU1A		0.25	50	600	-	15	2.5	0.25	10	400 ⁽²⁾
RU1B		0.25	50	800	-	15	2.5	0.25	10	400 ⁽²⁾
RU1C		0.20	50	1000	-	15	3.0	0.20	10	400 ⁽²⁾

AU01 Series, 0.5 A, Case Type: DO-41



AU01		0.5	25	400	-	15	1.7	0.5	10	400 ⁽²⁾
AU01A		0.5	25	600	-	15	1.7	0.5	10	400 ⁽²⁾
AU01Z		0.5	25	200	-	15	1.7	0.5	10	400 ⁽²⁾

ERA22-02 Series, 0.5 A, Case Type: DO-41



ERA22-02		0.5	40	200	-	10	1.5	0.5	10	400 ⁽³⁾
ERA22-04		0.5	40	400	-	10	1.5	0.5	10	400 ⁽³⁾
ERA22-06		0.5	40	600	-	10	1.5	0.5	10	400 ⁽³⁾
ERA22-08		0.5	40	800	-	10	1.5	0.5	10	400 ⁽³⁾
ERA22-10		0.5	40	1000	-	10	1.5	0.5	10	400 ⁽³⁾

ERB43-02 Series, 0.5 A, Case Type: DO-41



ERB43-02		0.5	40	200	-	10	1.2	0.5	10	400 ⁽³⁾
ERB43-04		0.5	40	400	-	10	1.2	0.5	10	400 ⁽³⁾
ERB43-06		0.5	40	600	-	10	1.2	0.5	10	400 ⁽³⁾
ERB43-08		0.5	40	800	-	10	1.2	0.5	10	400 ⁽³⁾

Notes :

- (1) Reverse recovery test conditions : I_F = 0.5 A, I_R = 1 A, with I_{rr} = 0.25 A
- (2) Reverse recovery test conditions : I_F = 10 mA, I_R = 10 mA recover to 1 mA
- (3) Reverse recovery test conditions : I_F = 100 mA, I_R = 100 mA

Fast Recovery Rectifier Diodes

The plastic material carries U/L recognition 94V-0.

Type No.	Max. Average Forward Rectified Current	Max. Repetitive Peak Reverse Voltage	Max. Repetitive Peak Forward Current	Max. Surge Forward Current	Max. Forward Voltage Drop at Ta=25°C	Max. Reverse Current at Ta=25°C	Max. Reverse Recovery Time	
								IF(AV) @ Ta
Axial Lead	SMD	(A) (°C)	(V)	(A)	(A)	(V) (A)	(μA)	(ns)

TVR1 Series, 0.5 A, Case Type: DO-41



TVR1B		0.5	60	100	-	10	1.2	0.5	10	75 ⁽¹⁾	300 ⁽³⁾
TVR1G		0.5	60	400	-	10	1.2	0.5	10	75 ⁽¹⁾	300 ⁽³⁾
TVR1J		0.5	60	600	-	10	1.2	0.5	10	75 ⁽¹⁾	300 ⁽³⁾

TVR2 Series, 0.5 A, Case Type: D2



TVR2B		0.5	60	100	-	30	1.4	1.0	10	20 ⁽⁴⁾
TVR2D		0.5	60	200	-	30	1.4	1.0	10	20 ⁽⁴⁾
TVR2G		0.5	60	400	-	30	1.4	1.0	10	20 ⁽⁴⁾
TVR2J		0.5	60	600	-	30	1.4	1.0	10	20 ⁽⁴⁾

S5295B Series, 0.5 A, Case Type: DO-41



S5295B		0.5	25	100	-	30	1.5	1.0	10	1.5μs ⁽⁴⁾
S5295G		0.5	25	400	-	30	1.5	1.0	10	1.5μs ⁽⁴⁾
S5295J		0.5	25	600	-	30	1.5	1.0	10	1.5μs ⁽⁴⁾

05NU41 Series, 0.5 A, Case Type: DO-41



05NU41		0.5	25	1000	-	10	3.0	0.5	100	100 ⁽⁵⁾
05NU42		0.5	25	1000	-	10	3.0	0.5	100	100 ⁽⁵⁾

RH1 Series, 0.6 A, Case Type: D2



RH1		0.6	50	400	-	35	1.3	0.6	5.0	4μs ⁽²⁾
RH1A		0.6	50	600	-	35	1.3	0.6	5.0	4μs ⁽²⁾
RH1B		0.6	50	800	-	35	1.3	0.6	5.0	4μs ⁽²⁾
RH1C		0.6	50	1000	-	35	1.3	0.6	5.0	4μs ⁽²⁾

ES1 Series, 0.5 - 0.7 A, Case Type: DO-41



ES1Z		0.7	25	200	-	30	2.5	0.8	10	1.5μs ⁽²⁾
ES1		0.7	25	400	-	30	2.5	0.8	10	1.5μs ⁽²⁾
ES1 A		0.7	25	600	-	30	2.5	0.8	10	1.5μs ⁽²⁾
ES1F		0.5	50	1500	-	20	2.0	0.5	10	1.5μs ⁽²⁾

AU02 Series, 0.8 A, Case Type: DO-41



AU02		0.8	25	400	-	25	1.3	0.8	10	400 ⁽³⁾
AU02A		0.8	25	600	-	25	1.3	0.8	10	400 ⁽³⁾
AU02Z		0.8	25	200	-	25	1.3	0.8	10	400 ⁽³⁾

Notes :

- (1) Reverse recovery test conditions : $I_F = 0.5 \text{ A}$, $I_R = 1 \text{ A}$, with $I_{rr} = 0.25 \text{ A}$
- (2) Reverse recovery test conditions : $I_F = 10 \text{ mA}$, $I_R = 10 \text{ mA}$ recover to 1 mA
- (3) Reverse recovery test conditions : $I_F = 100 \text{ mA}$, $I_R = 100 \text{ mA}$
- (4) Reverse recovery test conditions : $I_F = 20 \text{ mA}$, $I_R = 1 \text{ mA}$
- (5) Reverse recovery test conditions : $I_F = 1 \text{ A}$, $di/dt = -30 \text{ A/ms}$.

Fast Recovery Rectifier Diodes

The plastic material carries U/L recognition 94V-0.

Type No.		Max. Average Forward Rectified Current		Max. Repetitive Peak Reverse Voltage	Max. Repetitive Peak Forward Current	Max. Surge Forward Current	Max. Forward Voltage Drop at Ta=25°C		Max. Reverse Current at Ta=25°C	Max. Reverse Recovery Time
		I _{F(AV)}	@ Ta	V _{RRM}	I _{FRM}	I _{FSM}	V _F	@ I _F	I _R	T _{rr}
Axial Lead	SMD	(A)	(°C)	(V)	(A)	(A)	(V)	(A)	(μA)	(ns)

ERB38-04 Series, 0.8 A, Case Type: DO-41



ERB38-04		0.8	25	400	-	20	2.5	0.8	50	50 ⁽⁴⁾
ERB38-05		0.8	25	500	-	20	2.5	0.8	50	50 ⁽⁴⁾
ERB38-06		0.8	25	600	-	20	2.5	0.8	50	50 ⁽⁴⁾

1SR153-100 Series, 0.8 A, Case Type: DO-41



1SR153-100		0.8	55	100	-	30	1.3	0.8	10	400 ⁽³⁾	250 ⁽¹⁾
1SR153-200		0.8	55	200	-	30	1.3	0.8	10	400 ⁽³⁾	250 ⁽¹⁾
1SR153-400		0.8	55	400	-	30	1.3	0.8	10	400 ⁽³⁾	250 ⁽¹⁾

1SR124-100 Series, 1 A, Case Type: DO-41



1SR124-100		1.0	55	100	-	30	1.3	1.0	10	400 ⁽³⁾	250 ⁽¹⁾
1SR124-200		1.0	55	200	-	30	1.3	1.0	10	400 ⁽³⁾	250 ⁽¹⁾
1SR124-400		1.0	55	400	-	30	1.3	1.0	10	400 ⁽³⁾	250 ⁽¹⁾

ERB44-02 Series, 1 A, Case Type: DO-41



ERB44-02		1.0	40	200	-	30	1.1	1.0	10	400 ⁽²⁾
ERB44-04		1.0	40	400	-	30	1.1	1.0	10	400 ⁽²⁾
ERB44-06		1.0	40	600	-	30	1.1	1.0	10	400 ⁽²⁾
ERB44-08		1.0	40	800	-	30	1.1	1.0	10	400 ⁽²⁾
ERB44-10		1.0	40	1000	-	30	1.1	1.0	10	400 ⁽²⁾

EU2 Series, 1 - 1.2 A, Case Type: DO-41



EU2YX		1.2	25	70	-	25	0.9	1.2	10	200 ⁽³⁾
EU2Z		1.0	25	200	-	15	1.4	1.0	10	400 ⁽³⁾
EU2		1.0	25	400	-	15	1.4	1.0	10	400 ⁽³⁾
EU2A		1.0	25	600	-	15	1.4	1.0	10	400 ⁽³⁾

RGP10A Series, 1 A, Case Type: DO-41



RGP10A		1.0	55	50	-	30	1.3	1.0	5.0	150 ⁽¹⁾
RGP10B		1.0	55	100	-	30	1.3	1.0	5.0	150 ⁽¹⁾
RGP10D		1.0	55	200	-	30	1.3	1.0	5.0	150 ⁽¹⁾
RGP10G		1.0	55	400	-	30	1.3	1.0	5.0	150 ⁽¹⁾
RGP10J		1.0	55	600	-	30	1.3	1.0	5.0	250 ⁽¹⁾
RGP10K		1.0	55	800	-	30	1.3	1.0	5.0	500 ⁽¹⁾
RGP10M		1.0	55	1000	-	30	1.3	1.0	5.0	500 ⁽¹⁾

10ELS1 Series, 1 A, Case Type: D2



10ELS1		1.0	25	100	-	30	1.10	1.0	10	150 ⁽¹⁾
10ELS2		1.0	25	200	-	30	1.10	1.0	10	150 ⁽¹⁾
10ELS4		1.0	25	400	-	50	1.15	1.0	10	150 ⁽¹⁾
10ELS6		1.0	25	600	-	50	1.15	1.0	10	150 ⁽¹⁾

Notes:

- (1) Reverse recovery test conditions : I_F = 0.5 A, I_R = 1 A, with I_{rr} = 0.25 A
- (2) Reverse recovery test conditions : I_F = 100 mA, I_R = 100 mA
- (3) Reverse recovery test conditions : I_F = 10 mA, I_R = 10 mA recover to 1 mA
- (4) Reverse recovery test conditions : I_F = 100 mA, I_R = 200 mA

Fast Recovery Rectifier Diodes

The plastic material carries U/L recognition 94V-0.

Type No.		Max. Average Forward Rectified Current		Max. Repetitive Peak Reverse Voltage	Max. Repetitive Peak Forward Current	Max. Surge Forward Current	Max. Forward Voltage Drop at Ta=25°C		Max. Reverse Current at Ta=25°C	Max. Reverse Recovery Time
		I _{F(AV)}	@ Ta	V _{RRM}	I _{FRM}	I _{FSM}	V _F	@ I _F	I _R	T _{rr}
Axial Lead	SMD	(A)	(°C)	(V)	(A)	(A)	(V)	(A)	(μA)	(ns)

BA157/SRA7 Series, 1 A, Case Type: DO-41/SMA

BA157	SRA7	1.0	45	400	5.0	35	1.3	1.0	5.0	300 ⁽²⁾	150 ⁽¹⁾
BA158	SRA8	1.0	45	600	5.0	35	1.3	1.0	5.0	300 ⁽²⁾	150 ⁽¹⁾
BA159	SRA9	1.0	45	1000	5.0	35	1.3	1.0	5.0	500 ⁽²⁾	250 ⁽¹⁾

FR101/SR1A Series, 1 A, Case Type: DO-41/SMA

FR101	SR1A	1.0	55	50	5.0	35	1.3	1.0	5.0	150 ⁽¹⁾
FR102	SR1B	1.0	55	100	5.0	35	1.3	1.0	5.0	150 ⁽¹⁾
FR103	SR1D	1.0	55	200	5.0	35	1.3	1.0	5.0	150 ⁽¹⁾
FR104	SR1G	1.0	55	400	5.0	35	1.3	1.0	5.0	150 ⁽¹⁾
FR105	SR1J	1.0	55	600	5.0	35	1.3	1.0	5.0	250 ⁽¹⁾
FR106	SR1K	1.0	55	800	5.0	35	1.3	1.0	5.0	500 ⁽¹⁾
FR107	SR1M	1.0	55	1000	5.0	35	1.3	1.0	5.0	500 ⁽¹⁾
FR107-STR	-	1.0	55	1000	5.0	35	1.3	1.0	5.0	250 ⁽¹⁾

RS1 Series, 1 A, Case Type: SMA

	RS1A	1.0	90	50	-	30	1.30	1.0	5.0	150 ⁽¹⁾
	RS1B	1.0	90	100	-	30	1.30	1.0	5.0	150 ⁽¹⁾
	RS1D	1.0	90	200	-	30	1.30	1.0	5.0	150 ⁽¹⁾
	RS1G	1.0	90	400	-	30	1.30	1.0	5.0	150 ⁽¹⁾
	RS1J	1.0	90	600	-	30	1.30	1.0	5.0	250 ⁽¹⁾
	RS1K	1.0	90	800	-	30	1.30	1.0	5.0	500 ⁽¹⁾
	RS1M	1.0	90	1000	-	30	1.30	1.0	5.0	500 ⁽¹⁾

1N4933/SRN3 Series, 1 A, Case Type: DO-41/SMA

1N4933	SRN3	1.0	50	50	5.0	30	1.2	1.0	5.0	150 ⁽¹⁾
1N4934	SRN4	1.0	50	100	5.0	30	1.2	1.0	5.0	150 ⁽¹⁾
1N4935	SRN5	1.0	50	200	5.0	30	1.2	1.0	5.0	150 ⁽¹⁾
1N4936	SRN6	1.0	50	400	5.0	30	1.2	1.0	5.0	150 ⁽¹⁾
1N4937	SRN7	1.0	50	600	5.0	30	1.2	1.0	5.0	150 ⁽¹⁾

DL4933 Series, 1 A, Case Type: MELF (Plastic)

	DL4933	1.0	55	50	-	30	1.2	1.0	5.0	150 ⁽¹⁾
	DL4934	1.0	55	100	-	30	1.2	1.0	5.0	150 ⁽¹⁾
	DL4935	1.0	55	200	-	30	1.2	1.0	5.0	150 ⁽¹⁾
	DL4936	1.0	55	400	-	30	1.2	1.0	5.0	150 ⁽¹⁾
	DL4937	1.0	55	600	-	30	1.2	1.0	5.0	150 ⁽¹⁾

RGF1A Series, 1 A, Case Type: SMA

	RGF1A	1.0	125 (T _L)	50	-	30	1.3	1.0	5.0	150 ⁽¹⁾
	RGF1B	1.0	125 (T _L)	100	-	30	1.3	1.0	5.0	150 ⁽¹⁾
	RGF1D	1.0	125 (T _L)	200	-	30	1.3	1.0	5.0	150 ⁽¹⁾
	RGF1G	1.0	125 (T _L)	400	-	30	1.3	1.0	5.0	150 ⁽¹⁾
	RGF1J	1.0	125 (T _L)	600	-	30	1.3	1.0	5.0	250 ⁽¹⁾
	RGF1K	1.0	125 (T _L)	800	-	30	1.3	1.0	5.0	500 ⁽¹⁾
	RGF1M	1.0	125 (T _L)	1000	-	30	1.3	1.0	5.0	500 ⁽¹⁾

Notes :

- (1) Reverse recovery test conditions : I_F = 0.5 A, I_R = 1 A, with I_{rr} = 0.25 A
- (2) Reverse recovery test conditions : I_F = 10 mA, I_R = 10 mA recover to 1 mA



Fast Recovery Rectifier Diodes

The plastic material carries U/L recognition 94V-0.

Type No.		Max. Average Forward Rectified Current		Max. Repetitive Peak Reverse Voltage	Max. Repetitive Peak Forward Current	Max. Surge Forward Current	Max. Forward Voltage Drop at Ta=25°C		Max. Reverse Current at Ta=25°C	Max. Reverse Recovery Time
		I _{F(AV)}	@ Ta	V _{RRM}	I _{FRM}	I _{FSM}	V _F	@ I _F	I _R	T _{rr}
Axial Lead	SMD	(A)	(°C)	(V)	(A)	(A)	(V)	(A)	(μA)	(ns)

RU2 Series, 1 - 1.5 A, Case Type: D2



RU2Z		1.0	50	200	5.0	20	1.50	1.0	10	400 ⁽²⁾
RU2		1.0	50	600	5.0	20	1.50	1.0	10	400 ⁽²⁾
RU2B		1.0	50	800	5.0	20	1.50	1.0	10	400 ⁽²⁾
RU2M		1.1	50	400	5.0	20	1.20	1.1	10	400 ⁽²⁾
RU2AM		1.1	50	600	5.0	20	1.20	1.1	10	400 ⁽²⁾
RU2YX		1.5	50	100	5.0	30	0.95	1.5	10	200 ⁽²⁾
RU20A		1.5	25	600	-	50	1.10	1.5	10	400 ⁽³⁾

15DF4 Series, 1.3 A, Case Type: D2



15DF4		1.3	40	400	-	70	1.2	1.3	10	150 ⁽¹⁾
15DF6		1.3	40	600	-	70	1.2	1.3	10	150 ⁽¹⁾
15DF8		1.3	40	800	-	70	1.2	1.3	10	150 ⁽¹⁾

BYT52A Series, 1.4 A, Case Type: D2



BYT52A		1.4	25(T _L)	50	-	50	1.3	1.0	10	200 ⁽¹⁾
BYT52B		1.4	25(T _L)	100	-	50	1.3	1.0	10	200 ⁽¹⁾
BYT52D		1.4	25(T _L)	200	-	50	1.3	1.0	10	200 ⁽¹⁾
BYT52G		1.4	25(T _L)	400	-	50	1.3	1.0	10	200 ⁽¹⁾
BYT52J		1.4	25(T _L)	600	-	50	1.3	1.0	10	200 ⁽¹⁾
BYT52K		1.4	25(T _L)	800	-	50	1.3	1.0	10	200 ⁽¹⁾
BYT52M		1.4	25(T _L)	1000	-	50	1.3	1.0	10	200 ⁽¹⁾

RGP15A Series, 1.5 A, Case Type: D2



RGP15A		1.5	55	50	-	50	1.3	1.5	5.0	150 ⁽¹⁾
RGP15B		1.5	55	100	-	50	1.3	1.5	5.0	150 ⁽¹⁾
RGP15D		1.5	55	200	-	50	1.3	1.5	5.0	150 ⁽¹⁾
RGP15G		1.5	55	400	-	50	1.3	1.5	5.0	150 ⁽¹⁾
RGP15J		1.5	55	600	-	50	1.3	1.5	5.0	250 ⁽¹⁾
RGP15K		1.5	55	800	-	50	1.3	1.5	5.0	500 ⁽¹⁾
RGP15M		1.5	55	1000	-	50	1.3	1.5	5.0	500 ⁽¹⁾

FR151/SROA Series, 1.5 A, Case Type: DO-41/SMA



FR151	SROA	1.5	55	50	5.0	60	1.3	1.5	5.0	150 ⁽¹⁾
FR152	SROB	1.5	55	100	5.0	60	1.3	1.5	5.0	150 ⁽¹⁾
FR153	SROD	1.5	55	200	5.0	60	1.3	1.5	5.0	150 ⁽¹⁾
FR154	SROG	1.5	55	400	5.0	60	1.3	1.5	5.0	150 ⁽¹⁾
FR155	SROJ	1.5	55	600	5.0	60	1.3	1.5	5.0	250 ⁽¹⁾
FR156	SROK	1.5	55	800	5.0	60	1.3	1.5	5.0	500 ⁽¹⁾
FR157	SROM	1.5	55	1000	5.0	60	1.3	1.5	5.0	500 ⁽¹⁾
FR157-STR	-	1.5	55	1000	5.0	60	1.3	1.5	5.0	250 ⁽¹⁾

Notes :

- (1) Reverse recovery test conditions : I_F = 0.5 A, I_R = 1 A, with I_{rr} = 0.25 A
- (2) Reverse recovery test conditions : I_F = 10 mA, I_R = 10 mA recover to 1 mA
- (3) Reverse recovery test conditions : I_F = 100 mA, I_R = 100 mA

Fast Recovery Rectifier Diodes

The plastic material carries U/L recognition 94V-0.

Type No.		Max. Average Forward Rectified Current		Max. Repetitive Peak Reverse Voltage	Max. Repetitive Peak Forward Current	Max. Surge Forward Current	Max. Forward Voltage Drop at Ta=25°C		Max. Reverse Current at Ta=25°C	Max. Reverse Recovery Time
		I _{F(AV)}	@ Ta	V _{RRM}	I _{FRM}	I _{FSM}	V _F	@ I _F	I _R	T _{rr}
Axial Lead	SMD	(A)	(°C)	(V)	(A)	(A)	(V)	(A)	(μA)	(ns)

1R5J Series, 1.5 A, Case Type: D2



1R5JH45		1.5	25	600	-	50	1.2	1.5	100	200 ⁽⁴⁾
1R5JU41		1.5	25	600	-	40	2.0	2.0	100	100 ⁽⁴⁾

ERD28-04 Series, 1.5 A, Case Type: D2A



ERD28-04		1.5	25	400	-	70	1.1	1.5	10	400 ⁽³⁾
ERD28-06		1.5	25	600	-	70	1.1	1.5	10	400 ⁽³⁾
ERD28-08		1.5	25	800	-	70	1.1	1.5	10	400 ⁽³⁾

RU3 Series, 1.5 - 2.0 A, Case Type: D2A



RU3		1.5	50	400	-	30	1.5	1.5	10	400 ⁽²⁾
RU3A		1.5	50	600	-	30	1.5	1.5	10	400 ⁽²⁾
RU3B		1.5	50	800	-	30	1.5	1.5	10	400 ⁽²⁾
RU3C		1.5	50	1000	-	30	2.0	1.5	10	400 ⁽²⁾
RU3M		1.5	50	400	-	30	1.1	1.5	10	400 ⁽²⁾
RU3AM		1.5	50	600	-	30	1.1	1.5	10	400 ⁽²⁾
RU3YX		2.0	25	100	-	50	0.95	2.0	10	200 ⁽²⁾

RU4 Series, 1.5 - 2.5 A, Case Type: DO-201AD



RU4		1.5	50	400	-	50	1.5	3.0	10	400 ⁽²⁾
RU4A		1.5	50	600	-	50	1.5	3.0	10	400 ⁽²⁾
RU4B		1.5	50	800	-	50	1.6	3.0	10	400 ⁽²⁾
RU4C		1.5	50	1000	-	50	1.6	3.0	50	400 ⁽²⁾
RU4Y		2.0	60	100	-	70	1.3	3.5	10	400 ⁽²⁾
RU4Z		2.0	60	200	-	70	1.3	3.5	10	400 ⁽²⁾
RU4M		2.0	50	400	-	50	1.3	3.5	10	400 ⁽³⁾
RU4AM		2.0	50	600	-	50	1.3	3.5	10	400 ⁽³⁾
RU4YX		2.2	50	100	-	100	1.3	3.5	10	200 ⁽³⁾
RU4DS		2.5	60	1300	-	50	1.8	3.0	50	400 ⁽³⁾

BYW32 Series, 2 A, Case Type: D2



BYW32		2.0	55	200	-	40	1.2	2.0	5.0	200 ⁽¹⁾
BYW33		2.0	55	300	-	40	1.2	2.0	5.0	200 ⁽¹⁾
BYW34		2.0	55	400	-	40	1.2	2.0	5.0	200 ⁽¹⁾
BYW35		2.0	55	500	-	40	1.2	2.0	5.0	200 ⁽¹⁾
BYW36		2.0	55	600	-	40	1.2	2.0	5.0	200 ⁽¹⁾

BY296/SR26 Series, 2 A, Case Type: DO-201AD/SMC



BY296	SR26	2.0	50	100	10	70	1.3	2.0	10	500 ⁽²⁾	250 ⁽¹⁾
BY297	SR27	2.0	50	200	10	70	1.3	2.0	10	500 ⁽²⁾	250 ⁽¹⁾
BY298	SR28	2.0	50	400	10	70	1.3	2.0	10	500 ⁽²⁾	250 ⁽¹⁾
BY299	SR29	2.0	50	800	10	70	1.3	2.0	10	500 ⁽²⁾	250 ⁽¹⁾

Notes :

- (1) Reverse recovery test conditions : I_F = 0.5 A, I_R = 1 A, with I_{rr} = 0.25 A
- (2) Reverse recovery test conditions : I_F = 10 mA, I_R = 10 mA recover to 1 mA
- (3) Reverse recovery test conditions : I_F = 100 mA, I_R = 100 mA
- (4) Reverse recovery test conditions : I_F = 1 A, di/dt = -30 A/ms

Fast Recovery Rectifier Diodes

The plastic material carries U/L recognition 94V-0.

Type No.		Max. Average Forward Rectified Current		Max. Repetitive Peak Reverse Voltage	Max. Repetitive Peak Forward Current	Max. Surge Forward Current	Max. Forward Voltage Drop at Ta=25°C		Max. Reverse Current at Ta=25°C		Max. Reverse Recovery Time
		I _{F(AV)}	@ Ta	V _{RRM}	I _{FRM}	I _{FSM}	V _F	@ I _F	I _R	T _{rr}	
Axial Lead	SMD	(A)	(°C)	(V)	(A)	(A)	(V)	(A)	(μA)	(ns)	

FR201/SR2A Series, 2 A, Case Type: D2/SMB



FR201	SR2A	2.0	75	50	15	75	1.3	2.0	10	150 ⁽¹⁾
FR202	SR2B	2.0	75	100	15	75	1.3	2.0	10	150 ⁽¹⁾
FR203	SR2D	2.0	75	200	15	75	1.3	2.0	10	150 ⁽¹⁾
FR204	SR2G	2.0	75	400	15	75	1.3	2.0	10	150 ⁽¹⁾
FR205	SR2J	2.0	75	600	15	75	1.3	2.0	10	250 ⁽¹⁾
FR206	SR2K	2.0	75	800	15	75	1.3	2.0	10	500 ⁽¹⁾
FR207	SR2M	2.0	75	1000	15	75	1.3	2.0	10	500 ⁽¹⁾
FR207-STR	-	2.0	75	1000	15	75	1.3	2.0	10	250 ⁽¹⁾

RGP20A-J Series, 2 A, Case Type: D2A



RGP20A		2.0	55	50	-	80	1.3	2.0	5.0	150 ⁽¹⁾
RGP20B		2.0	55	100	-	80	1.3	2.0	5.0	150 ⁽¹⁾
RGP20D		2.0	55	200	-	80	1.3	2.0	5.0	150 ⁽¹⁾
RGP20G		2.0	55	400	-	80	1.3	2.0	5.0	150 ⁽¹⁾
RGP20J		2.0	55	600	-	80	1.3	2.0	5.0	250 ⁽¹⁾

FR251/SRTA Series, 2.5 A, Case Type: D2A/SMB



FR251	SRTA	2.5	75	50	15	100	1.3	2.5	10	150 ⁽¹⁾
FR252	SRTB	2.5	75	100	15	100	1.3	2.5	10	150 ⁽¹⁾
FR253	SRTD	2.5	75	200	15	100	1.3	2.5	10	150 ⁽¹⁾
FR254	SRTG	2.5	75	400	15	100	1.3	2.5	10	150 ⁽¹⁾
FR255	SRTJ	2.5	75	600	15	100	1.3	2.5	10	250 ⁽¹⁾
FR256	SRTK	2.5	75	800	15	100	1.3	2.5	10	500 ⁽¹⁾
FR257	SRTM	2.5	75	1000	15	100	1.3	2.5	10	500 ⁽¹⁾
FR257-STR	-	2.5	75	1000	15	100	1.3	2.5	10	250 ⁽¹⁾

BY228/SR36 Series, 3 A, Case Type: DO-201AD/SMC



BY396	SR36	3.0	50	100	15	100	1.25	3.0	10	500 ⁽²⁾	250 ⁽¹⁾
BY397	SR37	3.0	50	200	15	100	1.25	3.0	10	500 ⁽²⁾	250 ⁽¹⁾
BY398	SR38	3.0	50	400	15	100	1.25	3.0	10	500 ⁽²⁾	250 ⁽¹⁾
BY399	SR39	3.0	50	800	15	100	1.25	3.0	10	500 ⁽²⁾	250 ⁽¹⁾

BYT56A Series, 3 A, Case Type: DO-201AD



BYT56A		3.0	50	50	-	80	1.4	3.0	5.0	100 ⁽¹⁾
BYT56B		3.0	50	100	-	80	1.4	3.0	5.0	100 ⁽¹⁾
BYT56D		3.0	50	200	-	80	1.4	3.0	5.0	100 ⁽¹⁾
BYT56G		3.0	50	400	-	80	1.4	3.0	5.0	100 ⁽¹⁾
BYT56J		3.0	50	600	-	80	1.4	3.0	5.0	100 ⁽¹⁾
BYT56K		3.0	50	800	-	80	1.4	3.0	5.0	100 ⁽¹⁾
BYT56M		3.0	50	1000	-	80	1.4	3.0	5.0	100 ⁽¹⁾

Notes :

- (1) Reverse recovery test conditions : I_F = 0.5 A, I_R = 1 A, with I_{rr} = 0.25 A
- (2) Reverse recovery test conditions : I_F = 10 mA, I_R = 10 mA recover to 1 mA

Fast Recovery Rectifier Diodes

The plastic material carries U/L recognition 94V-0.

Type No.		Max. Average Forward Rectified Current		Max. Repetitive Peak Reverse Voltage	Max. Repetitive Peak Forward Current	Max. Surge Forward Current	Max. Forward Voltage Drop at Ta=25°C		Max. Reverse Current at Ta=25°C	Max. Reverse Recovery Time
		I _{F(AV)}	@ Ta	V _{RRM}	I _{FRM}	I _{FSM}	V _F	@ I _F	I _R	T _{rr}
Axial Lead	SMD	(A)	(°C)	(V)	(A)	(A)	(V)	(A)	(μA)	(ns)

FR301/SR3A Series, 3 A, Case Type: DO-201AD/SMC



FR301	SR3A	3.0	55	50	20	200	1.3	3.0	10	150 ⁽¹⁾
FR302	SR3B	3.0	55	100	20	200	1.3	3.0	10	150 ⁽¹⁾
FR303	SR3D	3.0	55	200	20	200	1.3	3.0	10	150 ⁽¹⁾
FR304	SR3G	3.0	55	400	20	200	1.3	3.0	10	150 ⁽¹⁾
FR305	SR3J	3.0	55	600	20	200	1.3	3.0	10	250 ⁽¹⁾
FR306	SR3K	3.0	55	800	20	200	1.3	3.0	10	500 ⁽¹⁾
FR307	SR3M	3.0	55	1000	20	200	1.3	3.0	10	500 ⁽¹⁾
FR307-STR		3.0	55	1000	20	200	1.3	3.0	10	250 ⁽¹⁾

RS3A Series, 3 A, Case Type: SMC



	RS3A	3.0	55	50	-	100	1.3	3.0	10	150 ⁽¹⁾
	RS3B	3.0	55	100	-	100	1.3	3.0	10	150 ⁽¹⁾
	RS3D	3.0	55	200	-	100	1.3	3.0	10	150 ⁽¹⁾
	RS3G	3.0	55	400	-	100	1.3	3.0	10	150 ⁽¹⁾
	RS3J	3.0	55	600	-	100	1.3	3.0	10	250 ⁽¹⁾
	RS3K	3.0	55	800	-	100	1.3	3.0	10	500 ⁽¹⁾

MR850/SRR0 Series, 3 A, Case Type: DO-201AD/SMC



MR850	SRR0	3.0	90	50	15	100	1.25	3.0	10	200 ⁽²⁾	150 ⁽¹⁾
MR851	SRR1	3.0	90	100	15	100	1.25	3.0	10	200 ⁽²⁾	150 ⁽¹⁾
MR852	SRR2	3.0	90	200	15	100	1.25	3.0	10	200 ⁽²⁾	150 ⁽¹⁾
MR854	SRR4	3.0	90	400	15	100	1.25	3.0	10	200 ⁽²⁾	150 ⁽¹⁾
MR856	SRR6	3.0	90	600	15	100	1.25	3.0	10	200 ⁽²⁾	150 ⁽¹⁾
MR858	-	3.0	90	800	15	100	1.25	3.0	10	200 ⁽²⁾	150 ⁽¹⁾

3JH45 Series, 3 A, Case Type: DO-201AD



3JH45	-	3.0	25	600	-	77	1.2	3.0	100	200 ⁽⁴⁾
30DF6	-	3.0	40	600	-	90	1.25	3.0	10	200 ⁽³⁾

RGP30 Series, 3 A, Case Type: DO-201AD



RGP30A		3.0	55	50	-	125	1.30	3.0	5.0	150 ⁽¹⁾
RGP30B		3.0	55	100	-	125	1.30	3.0	5.0	150 ⁽¹⁾
RGP30D		3.0	55	200	-	125	1.30	3.0	5.0	150 ⁽¹⁾
RGP30G		3.0	55	400	-	125	1.30	3.0	5.0	150 ⁽¹⁾
RGP30J		3.0	55	600	-	125	1.30	3.0	5.0	150 ⁽¹⁾
RGP30K		3.0	55	800	-	125	1.30	3.0	5.0	250 ⁽¹⁾
RGP30M		3.0	55	1000	-	125	1.30	3.0	5.0	500 ⁽¹⁾

1N5415 Series, 3 A, Case Type: D2A



1N5415		3.0	55	50	-	80	1.1	3.0	1.0	150 ⁽¹⁾
1N5416		3.0	55	100	-	80	1.1	3.0	1.0	150 ⁽¹⁾
1N5417		3.0	55	200	-	80	1.1	3.0	1.0	150 ⁽¹⁾
1N5418		3.0	55	400	-	80	1.1	3.0	1.0	150 ⁽¹⁾
1N5419		3.0	55	500	-	80	1.1	3.0	1.0	250 ⁽¹⁾
1N5420		3.0	55	600	-	80	1.1	3.0	1.0	400 ⁽¹⁾

Notes :

- (1) Reverse recovery test conditions : I_F = 0.5 A, I_R = 1 A, with I_{rr} = 0.25 A
- (2) Reverse recovery test conditions : I_F = 1 A, to V_R = 30 V



Fast Recovery Rectifier Diodes

The plastic material carries U/L recognition 94V-0.

Type No.		Max. Average Forward Rectified Current		Max. Repetitive Peak Reverse Voltage	Max. Repetitive Peak Forward Current	Max. Surge Forward Current	Max. Forward Voltage Drop at Ta=25°C		Max. Reverse Current at Ta=25°C	Max. Reverse Recovery Time
		I _{F(AV)} (A)	@ Ta (°C)	V _{RRM} (V)	I _{FRM} (A)	I _{FSM} (A)	V _F (V)	@ I _F (A)	I _R (μA)	T _{rr} (ns)

FR501 Series, 5 A, Case Type: DO-201AD



FR501	-	5.0	75	50	-	300	1.3	5.0	10	150 ⁽¹⁾
FR502	-	5.0	75	100	-	300	1.3	5.0	10	150 ⁽¹⁾
FR503	-	5.0	75	200	-	300	1.3	5.0	10	150 ⁽¹⁾
FR504	-	5.0	75	400	-	300	1.3	5.0	10	150 ⁽¹⁾
FR505	-	5.0	75	600	-	300	1.3	5.0	10	250 ⁽¹⁾
FR506	-	5.0	75	800	-	300	1.3	5.0	10	500 ⁽¹⁾
FR507	-	5.0	75	1000	-	300	1.3	5.0	10	500 ⁽¹⁾

FR601 Series, 6 A, Case Type: D6



FR601	-	6.0	55	50	-	200	1.3	6.0	10	150 ⁽¹⁾
FR602	-	6.0	55	100	-	200	1.3	6.0	10	150 ⁽¹⁾
FR603	-	6.0	55	200	-	200	1.3	6.0	10	150 ⁽¹⁾
FR604	-	6.0	55	400	-	200	1.3	6.0	10	150 ⁽¹⁾
FR605	-	6.0	55	600	-	200	1.3	6.0	10	250 ⁽¹⁾
FR606	-	6.0	55	800	-	200	1.3	6.0	10	500 ⁽¹⁾
FR607	-	6.0	55	1000	-	200	1.3	6.0	10	500 ⁽¹⁾

FR801 Series, 8 A, Case Type: D6



FR801	-	8.0	100 (Tc)	50	-	150	1.3	8.0	10	150 ⁽¹⁾
FR802	-	8.0	100 (Tc)	100	-	150	1.3	8.0	10	150 ⁽¹⁾
FR803	-	8.0	100 (Tc)	200	-	150	1.3	8.0	10	150 ⁽¹⁾
FR804	-	8.0	100 (Tc)	400	-	150	1.3	8.0	10	150 ⁽¹⁾
FR805	-	8.0	100 (Tc)	600	-	150	1.3	8.0	10	250 ⁽¹⁾

ESAC25 Series, 10 A, Case Type: TO - 220AB

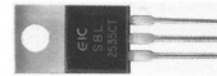

ESAC25-02C	-	10	106 (Tc)	200	-	70	1.3	2.5	10	400 ⁽²⁾
ESAC25-02D	-	10	106 (Tc)	200	-	70	1.3	2.5	10	400 ⁽²⁾
ESAC25-02N	-	10	106 (Tc)	200	-	70	1.3	2.5	10	400 ⁽²⁾
ESAC25-04C	-	10	106 (Tc)	400	-	70	1.3	2.5	10	400 ⁽²⁾
ESAC25-04D	-	10	106 (Tc)	400	-	70	1.3	2.5	10	400 ⁽²⁾
ESAC25-04N	-	10	106 (Tc)	400	-	70	1.3	2.5	10	400 ⁽²⁾

F1200A Series, 12 A, Case Type: D6



F1200A	-	12	50	50	80	390	0.85	5.0	25	200 ⁽¹⁾
F1200D	-	12	50	200	80	390	0.85	5.0	25	200 ⁽¹⁾

Notes :

- (1) Reverse Recovery test conditions : I_F = 0.5 A, I_R = 1 A, with I_{rr} = 0.25 A
- (2) Reverse Recovery test conditions : I_F = 100 mA, I_R = 100 mA
- (3) Reverse Recovery test conditions : I_F = 1 A, to V_R = 30 V
- (4) Reverse Recovery test conditions : I_F = 1 A, di/dt = -30 A/ms

Fast Recovery Glass Passivated Rectifier Diodes

The plastic material carries U/L recognition 94V-0.

Type No.		Max. Average Forward Rectified Current		Max. Repetitive Peak Reverse Voltage	Max. Repetitive Peak Forward Current	Max. Surge Forward Current	Max. Forward Voltage Drop at Ta=25°C		Max. Reverse Current at Ta=25°C	Max. Reverse Recovery Time
		I _{F(AV)}	@ Ta	V _{RRM}	I _{FRM}	I _{FSM}	V _F	@ I _F	I _R	T _{rr} ⁽¹⁾
Axial Lead	SMD	(A)	(°C)	(V)	(A)	(A)	(V)	(A)	(μA)	(ns)

LMR1A/SMR1A Series, 1 A, Case Type: M1A/SOD-123FL



LMR1A	SMR1A	1.0	50	50	-	30	1.0	1.0	5.0	150
LMR1B	SMR1B	1.0	50	100	-	30	1.0	1.0	5.0	150
LMR1D	SMR1D	1.0	50	200	-	30	1.0	1.0	5.0	150
LMR1G	SMR1G	1.0	50	400	-	30	1.0	1.0	5.0	150
LMR1J	SMR1J	1.0	50	600	-	30	1.0	1.0	5.0	250
LMR1K	SMR1K	1.0	50	800	-	30	1.0	1.0	5.0	500
LMR1M	SMR1M	1.0	50	1000	-	30	1.0	1.0	5.0	500

FR101G/GR1A Series, 1 A, Case Type: DO-41/SMA



FR101G	GR1A	1.0	55	50	5.0	30	1.3	1.0	5.0	150
FR102G	GR1B	1.0	55	100	5.0	30	1.3	1.0	5.0	150
FR103G	GR1D	1.0	55	200	5.0	30	1.3	1.0	5.0	150
FR104G	GR1G	1.0	55	400	5.0	30	1.3	1.0	5.0	150
FR105G	GR1J	1.0	55	600	5.0	30	1.3	1.0	5.0	250
FR106G	GR1K	1.0	55	800	5.0	30	1.3	1.0	5.0	500
FR107G	GR1M	1.0	55	1000	5.0	30	1.3	1.0	5.0	500
FR107G-STR	-	1.0	55	1000	5.0	30	1.3	1.0	5.0	250

FR151G Series, 1.5 A, Case Type: DO-41



FR151G		1.5	55	50	-	60	1.4	1.5	5.0	150
FR152G		1.5	55	100	-	60	1.4	1.5	5.0	150
FR153G		1.5	55	200	-	60	1.4	1.5	5.0	150
FR154G		1.5	55	400	-	60	1.4	1.5	5.0	150
FR155G		1.5	55	600	-	60	1.4	1.5	5.0	250
FR156G		1.5	55	800	-	60	1.4	1.5	5.0	500
FR157G		1.5	55	1000	-	60	1.4	1.5	5.0	500
FR157G-STR		1.5	55	1000	-	60	1.4	1.5	5.0	250

1N4933G/GRN3 Series, 1 A, Case Type: DO-41/SMA



1N4933G	GRN3	1.0	50	50	5.0	30	1.2	1.0	5.0	150
1N4934G	GRN4	1.0	50	100	5.0	30	1.2	1.0	5.0	150
1N4935G	GRN5	1.0	50	200	5.0	30	1.2	1.0	5.0	150
1N4936G	GRN6	1.0	50	400	5.0	30	1.2	1.0	5.0	150
1N4937G	GRN7	1.0	50	600	5.0	30	1.2	1.0	5.0	150

Note :

(1) Reverse Recovery test conditions : I_F = 0.5 A, I_R = 1 A, I_{rr} = 0.25 A



Fast Recovery Glass Passivated Rectifier Diodes

The plastic material carries U/L recognition 94V-0.

Type No.		Max. Average Forward Rectified Current		Max. Repetitive Peak Reverse Voltage	Max. Repetitive Peak Forward Current	Max. Surge Forward Current	Max. Forward Voltage Drop at Ta=25°C		Max. Reverse Current at Ta=25°C	Max. Reverse Recovery Time
		I _{F(AV)}	@ Ta	V _{RRM}	I _{FRM}	I _{FSM}	V _F	@ I _F	I _R	T _{rr} ⁽¹⁾
Axial Lead	SMD	(A)	(°C)	(V)	(A)	(A)	(V)	(A)	(μA)	(ns)

FR201G/GR2A Series, 2 A, Case Type: D2/SMB



FR201G	GR2A	2.0	75	50	10	75	1.3	2.0	10	150
FR202G	GR2B	2.0	75	100	10	75	1.3	2.0	10	150
FR203G	GR2D	2.0	75	200	10	75	1.3	2.0	10	150
FR204G	GR2G	2.0	75	400	10	75	1.3	2.0	10	150
FR205G	GR2J	2.0	75	600	10	75	1.3	2.0	10	250
FR206G	GR2K	2.0	75	800	10	75	1.3	2.0	10	500
FR207G	GR2M	2.0	75	1000	10	75	1.3	2.0	10	500
FR207G-STR	-	2.0	75	1000	10	75	1.3	2.0	10	250

FR251G Series, 2.5 A, Case Type: D2A



FR251G		2.5	75	50	-	80	1.3	2.5	10	150
FR252G		2.5	75	100	-	80	1.3	2.5	10	150
FR253G		2.5	75	200	-	80	1.3	2.5	10	150
FR254G		2.5	75	400	-	80	1.3	2.5	10	150
FR255G		2.5	75	600	-	80	1.3	2.5	10	250
FR256G		2.5	75	800	-	80	1.3	2.5	10	500
FR257G		2.5	75	1000	-	80	1.3	2.5	10	500
FR257G-STR		2.5	75	1000	-	80	1.3	2.5	10	250

FR301G/GR3A Series, 3 A, Case Type: DO-201AD/SMC



FR301G	GR3A	3.0	55	50	15	100	1.3	3.0	5.0	150
FR302G	GR3B	3.0	55	100	15	100	1.3	3.0	5.0	150
FR303G	GR3D	3.0	55	200	15	100	1.3	3.0	5.0	150
FR304G	GR3G	3.0	55	400	15	100	1.3	3.0	5.0	150
FR305G	GR3J	3.0	55	600	15	100	1.3	3.0	5.0	250
FR306G	GR3K	3.0	55	800	15	100	1.3	3.0	5.0	500
FR307G	GR3M	3.0	55	1000	15	100	1.3	3.0	5.0	500
FR307G-STR	-	3.0	55	1000	15	100	1.3	3.0	5.0	250

Note :

(1) Reverse Recovery test conditions : I_F = 0.5 A, I_R = 1 A, I_{rr} = 0.25 A

High Efficient Rectifier Diodes

The plastic material carries U/L recognition 94V-0.

Type No.	Max. Average Forward Rectified Current IF(AV) @ Ta	Max. Repetitive Peak Reverse Voltage VRRM	Max. Repetitive Peak Forward Current IFRM	Max. Forward Surge Current IFSM	Max. Forward Voltage Drop at Ta=25°C		Max. Reverse Current at Ta=25°C IR	Max. Reverse Recovery Time Trr ⁽¹⁾	
					VF @ IF	IF			
Axial Lead	SMD	(A)	(°C)	(V)	(A)	(V)	(A)	(μA)	(ns)

1H1G/SME1A Series, 1 A, Case Type: M1A /SOD-123FL



1H1G	SME1A	1.0	25	50	-	25	1.0	1.0	5.0	50
1H2G	SME1B	1.0	25	100	-	25	1.0	1.0	5.0	50
1H3G	SME1D	1.0	25	200	-	25	1.0	1.0	5.0	50
1H4G	SME1E1	1.0	25	300	-	25	1.3	1.0	5.0	50
1H5G	SME1G	1.0	25	400	-	25	1.3	1.0	5.0	50
1H5PG	-	1.0	25	400	-	25	1.0	1.0	5.0	50
1H6G	SME1J	1.0	25	600	-	25	1.7	1.0	5.0	75
1H7G	SME1K	1.0	25	800	-	25	1.7	1.0	5.0	75
1H8G	SME1M	1.0	25	1000	-	25	1.7	1.0	5.0	75

HER101/SE1A Series, 1 A, Case Type: DO-41/SMA



HER101	SE1A	1.0	55	50	5.0	30	1.1	1.0	5.0	50
HER102	SE1B	1.0	55	100	5.0	30	1.1	1.0	5.0	50
HER103	SE1D	1.0	55	200	5.0	30	1.1	1.0	5.0	50
HER104	SE1E	1.0	55	300	5.0	30	1.1	1.0	5.0	50
HER105	SE1G	1.0	55	400	5.0	30	1.1	1.0	5.0	50
HER106	SE1J	1.0	55	600	5.0	30	1.7	1.0	5.0	75
HER107	SE1K	1.0	55	800	5.0	30	1.7	1.0	5.0	75
HER108	SE1M	1.0	55	1000	5.0	30	1.7	1.0	5.0	75

HER151/SE0A Series, 1.5 A, Case Type: DO-41/SMA



HER151	SE0A	1.5	55	50	5.0	60	1.1	1.5	5.0	50
HER152	SE0B	1.5	55	100	5.0	60	1.1	1.5	5.0	50
HER153	SE0D	1.5	55	200	5.0	60	1.1	1.5	5.0	50
HER154	SE0E	1.5	55	300	5.0	60	1.1	1.5	5.0	50
HER155	SE0G	1.5	55	400	5.0	60	1.1	1.5	5.0	50
HER156	SE0J	1.5	55	600	5.0	60	1.7	1.5	5.0	75
HER157	SE0K	1.5	55	800	5.0	60	1.7	1.5	5.0	75
HER158	SE0M	1.5	55	1000	5.0	60	1.7	1.5	5.0	75

HER201/SE2A Series, 2 A, Case Type: D2/SMB



HER201	SE2A	2.0	55	50	10	75	1.1	2.0	10	50
HER202	SE2B	2.0	55	100	10	75	1.1	2.0	10	50
HER203	SE2D	2.0	55	200	10	75	1.1	2.0	10	50
HER204	SE2E	2.0	55	300	10	75	1.1	2.0	10	50
HER205	SE2G	2.0	55	400	10	75	1.1	2.0	10	50
HER206	SE2J	2.0	55	600	10	75	1.7	2.0	10	75
HER207	SE2K	2.0	55	800	10	75	1.7	2.0	10	75
HER208	SE2M	2.0	55	1000	10	75	1.7	2.0	10	75

Note : (1) Reverse Recovery test conditions : $I_F = 0.5 \text{ A}$, $I_R = 1 \text{ A}$, $I_{rr} = 0.25 \text{ A}$



High Efficient Rectifier Diodes

The plastic material carries U/L recognition 94V-0.

Type No.	Max. Average Forward Rectified Current		Max. Repetitive Peak Reverse Voltage	Max. Repetitive Peak Forward Current	Max. Forward Surge Current	Max. Forward Voltage Drop at Ta=25°C		Max. Reverse Current at Ta=25°C	Max. Reverse Recovery Time	
	I _{F(AV)}	@ Ta	V _{RRM}	I _{FRM}	I _{FSM}	V _F	@ I _F	I _R	T _{rr} ⁽¹⁾	
Axial Lead	SMD	(A)	(°C)	(V)	(A)	(A)	(V)	(A)	(μA)	(ns)

HER251/SETA Series, 2.5 A, Case Type: D2A/SMB



HER251	SETA	2.5	55	50	10	100	1.1	2.5	10	50
HER252	SETB	2.5	55	100	10	100	1.1	2.5	10	50
HER253	SETD	2.5	55	200	10	100	1.1	2.5	10	50
HER254	SETE	2.5	55	300	10	100	1.1	2.5	10	50
HER255	SETG	2.5	55	400	10	100	1.1	2.5	10	50
HER256	SETJ	2.5	55	600	10	100	1.7	2.5	10	75
HER257	SETK	2.5	55	800	10	100	1.7	2.5	10	75
HER258	SETM	2.5	55	1000	10	100	1.7	2.5	10	75

HER301/SE3A Series, 3 A, Case Type: DO-201AD/SMC



HER301	SE3A	3.0	55	50	15	150	1.1	3.0	10	50
HER302	SE3B	3.0	55	100	15	150	1.1	3.0	10	50
HER303	SE3D	3.0	55	200	15	150	1.1	3.0	10	50
HER304	SE3E	3.0	55	300	15	150	1.1	3.0	10	50
HER305	SE3G	3.0	55	400	15	150	1.1	3.0	10	50
HER306	SE3J	3.0	55	600	15	150	1.7	3.0	10	75
HER307	SE3K	3.0	55	800	15	150	1.7	3.0	10	75
HER308	SE3M	3.0	55	1000	15	150	1.7	3.0	10	75

HER501/SE5A Series, 5 A, Case Type: DO-201AD/SMC



HER501	SE5A	5.0	55	50	25	200	1.1	5.0	10	50
HER502	SE5B	5.0	55	100	25	200	1.1	5.0	10	50
HER503	SE5D	5.0	55	200	25	200	1.1	5.0	10	50
HER504	SE5E	5.0	55	300	25	200	1.1	5.0	10	50
HER505	SE5G	5.0	55	400	25	200	1.1	5.0	10	50
HER506	SE5J	5.0	55	600	25	200	1.7	5.0	10	75
HER507	SE5K	5.0	55	800	25	200	1.7	5.0	10	75
HER508	SE5M	5.0	55	1000	25	200	1.7	5.0	10	75

HER601 Series, 6 A, Case Type: D6



HER601		6.0	55	50	25	200	1.1	6.0	10	50
HER602		6.0	55	100	25	200	1.1	6.0	10	50
HER603		6.0	55	200	25	200	1.1	6.0	10	50
HER604		6.0	55	300	25	200	1.1	6.0	10	50
HER605		6.0	55	400	25	200	1.1	6.0	10	50
HER606		6.0	55	600	25	200	1.7	6.0	10	75
HER607		6.0	55	800	25	200	1.7	6.0	10	75
HER608		6.0	55	1000	25	200	1.7	6.0	10	75

Note : (1) Reverse Recovery test conditions : I_F = 0.5 A, I_R = 1 A, I_{rr} = 0.25 A

Super Fast Rectifier Diodes

The plastic material carries U/L recognition 94V-0.

Type No.	Max. Average Forward Rectified Current		Max. Repetitive Peak Reverse Voltage	Max. Repetitive Peak Forward Current	Max. Forward Surge Current	Max. Forward Voltage Drop at Ta=25°C		Max. Reverse Current at Ta=25°C	Max. Reverse Recovery Time	
	I _{F(AV)}	@ Ta	V _{RRM}	I _{FRM}	I _{FSM}	V _F	@ I _F	I _R	T _{rr}	
Axial Lead	SMD	(A)	(°C)	(V)	(A)	(A)	(V)	(A)	(μA)	(ns)

AG01 Series, 0.5-1 A, Case Type: DO-41



AG01Y		1.0	25	70	-	25	1.2	1.0	100	100 ⁽²⁾
AG01Z		0.7	25	200	-	15	1.8	0.7	100	100 ⁽²⁾
AG01		0.7	25	400	-	15	1.8	0.7	100	100 ⁽²⁾
AG01A		0.5	25	600	-	15	1.8	0.5	100	100 ⁽²⁾

EG01 Series, 0.5 - 1 A, Case Type: DO-41



EG01Y		1.0	50	70	-	30	1.2	1.0	100	100 ⁽²⁾
EG01Z		0.7	50	200	-	15	1.9	0.7	50	100 ⁽²⁾
EG01		0.7	50	400	-	15	2.0	0.7	50	100 ⁽²⁾
EG01A		0.5	25	600	-	10	2.0	0.5	100	100 ⁽²⁾
EG01C		0.5	25	1000	-	10	3.3	0.5	50	100 ⁽²⁾

EG1 Series, 0.6 - 1 A, Case Type: DO-41



EG1Y		1.1	50	70	-	30	1.2	1.1	100	100 ⁽²⁾
EG1Z		0.8	50	200	-	15	1.7	0.8	50	100 ⁽²⁾
EG1		0.8	50	400	-	15	1.8	0.8	50	100 ⁽²⁾
EG1A		0.6	25	600	-	10	2.0	0.6	100	100 ⁽²⁾

ERA32-01 Series, 1 A, Case Type: DO-41



ERA32-01		1.0	40	100	-	40	0.92	1.0	10	100 ⁽²⁾
ERA32-02		1.0	40	200	-	40	0.92	1.0	10	100 ⁽²⁾

11DF1 Series, 1 A, Case Type: DO-41



11DF1		1.0	63	100	-	30	0.98	1.0	10	35 ⁽¹⁾
11DF2		1.0	63	200	-	30	0.98	1.0	10	35 ⁽¹⁾
11DF3		1.0	57	300	-	30	1.25	1.0	10	35 ⁽¹⁾
11DF4		1.0	57	400	-	30	1.25	1.0	10	35 ⁽¹⁾

MUR120 Series, 1 A, Case Type: DO-41



MUR120		1.0	25	200	-	35	0.875	1.0	2.0	25 ⁽¹⁾
MUR140		1.0	25	400	-	35	1.25	1.0	5.0	50 ⁽¹⁾
MUR160		1.0	25	600	-	35	1.25	1.0	5.0	50 ⁽¹⁾

RG10 Series, 1 - 1.5 A, Case Type: D2



RG10Y		1.5	55	70	5.0	50	1.1	1.5	500	35 ⁽¹⁾
RG10		1.2	55	400	5.0	50	1.8	1.5	500	35 ⁽¹⁾
RG10A		1.0	55	600	5.0	50	2.0	1.0	500	35 ⁽¹⁾

Notes:

- (1) Reverse Recovery test conditions : I_F = 0.5 A, I_R = 1 A, I_{rr} = 0.25 A
- (2) Reverse Recovery test conditions : I_F = 100 mA, I_R = 100 mA

Super Fast Rectifier Diodes

The plastic material carries U/L recognition 94V-0.

Type No.	Max. Average Forward Rectified Current		Max. Repetitive Peak Reverse Voltage	Max. Repetitive Peak Forward Current	Max. Forward Surge Current	Max. Forward Voltage Drop at Ta=25°C		Max. Reverse Current at Ta=25°C	Max. Reverse Recovery Time	
	I _{F(AV)}	@ Ta	V _{RRM}	I _{FRM}	I _{FSM}	V _F	@ I _F	I _R	T _{rr}	
Axial Lead	SMD	(A)	(°C)	(V)	(A)	(A)	(V)	(A)	(μA)	(ns)

UF1001 Series, 1 A, Case Type: DO-41



UF1001		1.0	55	50	-	30	1.10	1.0	5.0	50 ⁽¹⁾
UF1002		1.0	55	100	-	30	1.10	1.0	5.0	50 ⁽¹⁾
UF1003		1.0	55	200	-	30	1.10	1.0	5.0	50 ⁽¹⁾
UF1004		1.0	55	400	-	30	1.10	1.0	5.0	50 ⁽¹⁾
UF1005		1.1	55	600	-	30	1.70	1.0	5.0	75 ⁽¹⁾
UF1006		1.0	55	800	-	30	1.70	1.0	5.0	75 ⁽¹⁾
UF1007		1.0	55	1000	-	30	1.70	1.0	5.0	75 ⁽¹⁾

UF4001 Series, 1 A, Case Type: DO-41



UF4001		1.0	55	50	-	30	1.00	1.0	10	50 ⁽¹⁾
UF4002		1.0	55	100	-	30	1.00	1.0	10	50 ⁽¹⁾
UF4003		1.0	55	200	-	30	1.00	1.0	10	50 ⁽¹⁾
UF4004		1.0	55	400	-	30	1.00	1.0	10	50 ⁽¹⁾
UF4005		1.0	55	600	-	30	1.70	1.0	10	75 ⁽¹⁾
UF4006		1.0	55	800	-	30	1.70	1.0	10	75 ⁽¹⁾
UF4007		1.0	55	1000	-	30	1.70	1.0	10	75 ⁽¹⁾

SF11/SS1A Series, 1 A, Case Type: DO-41/SMA



SF11	SS1A	1.0	55	50	5.0	30	0.95	1.0	5.0	35 ⁽¹⁾
SF12	SS1B	1.0	55	100	5.0	30	0.95	1.0	5.0	35 ⁽¹⁾
SF13	SS1C	1.0	55	150	5.0	30	0.95	1.0	5.0	35 ⁽¹⁾
SF14	SS1D	1.0	55	200	5.0	30	0.95	1.0	5.0	35 ⁽¹⁾
SF15	SS1E	1.0	55	300	5.0	30	1.70	1.0	5.0	35 ⁽¹⁾
SF16	SS1G	1.0	55	400	5.0	30	1.70	1.0	5.0	35 ⁽¹⁾
SF17	SS1J	1.0	55	600	5.0	30	1.70	1.0	5.0	35 ⁽¹⁾
SF18	SS1K	1.0	55	800	5.0	30	4.00	1.0	10	35 ⁽¹⁾
SF19	SS1M	1.0	55	1000	5.0	30	4.00	1.0	10	35 ⁽¹⁾

ES1A Series, 1 A, Case Type: SMA



	ES1A	1.0	120(T _L)	50	-	30	0.95	1.0	5.0	35 ⁽¹⁾
	ES1B	1.0	120(T _L)	100	-	30	0.95	1.0	5.0	35 ⁽¹⁾
	ES1C	1.0	120(T _L)	150	-	30	0.95	1.0	5.0	35 ⁽¹⁾
	ES1D	1.0	120(T _L)	200	-	30	0.95	1.0	5.0	35 ⁽¹⁾
	ES1E	1.0	120(T _L)	300	-	30	1.25	1.0	5.0	35 ⁽¹⁾
	ES1G	1.0	120(T _L)	400	-	30	1.25	1.0	5.0	35 ⁽¹⁾
	ES1J	1.0	120(T _L)	600	-	30	1.70	1.0	5.0	35 ⁽¹⁾
	ES1K	1.0	55	800	-	30	4.00	1.0	10	35 ⁽¹⁾
	ES1M	1.0	55	1000	-	30	4.00	1.0	10	35 ⁽¹⁾

Notes:

- (1) Reverse Recovery test conditions : I_F = 0.5 A, I_R = 1 A, I_{rr} = 0.25 A
- (2) Reverse Recovery test conditions : I_F = 100 mA, I_R = 100 mA

Super Fast Rectifier Diodes

The plastic material carries U/L recognition 94V-0.

Type No.	Max. Average Forward Rectified Current		Max. Repetitive Peak Reverse Voltage	Max. Repetitive Peak Forward Current	Max. Forward Surge Current	Max. Forward Voltage Drop at Ta=25°C		Max. Reverse Current at Ta=25°C	Max. Reverse Recovery Time	
	I _{F(AV)}	@ Ta	V _{RRM}	I _{FRM}	I _{FSM}	V _F	@ I _F	I _R	T _{rr}	
Axial Lead	SMD	(A)	(°C)	(V)	(A)	(A)	(V)	(A)	(μA)	(ns)

RG2 Series, 1 - 1.5 A, Case Type: D2



RG2Y		1.5	60	70	5.0	50	1.1	1.5	500	35 ⁽¹⁾	100 ⁽²⁾
RG2Z		1.2	60	200	5.0	50	1.5	1.5	500	35 ⁽¹⁾	100 ⁽²⁾
RG2		1.2	60	400	5.0	50	1.8	1.5	500	35 ⁽¹⁾	100 ⁽²⁾
RG2A		1.0	60	600	5.0	50	2.0	1.0	500	35 ⁽¹⁾	100 ⁽²⁾

RG4 Series, 1 - 2.0 A, Case Type: DO-201AD



RG4Y		2.0	60	70	-	100	1.3	3.5	1000	35 ⁽¹⁾	100 ⁽²⁾
RG4Z		1.0	60	200	-	80	1.7	3.0	1000	35 ⁽¹⁾	100 ⁽²⁾
RG4		1.0	60	400	-	80	1.8	3.0	500	35 ⁽¹⁾	100 ⁽²⁾
RG4A		1.0	60	600	-	50	2.0	2.0	500	35 ⁽¹⁾	100 ⁽²⁾

EL1 Series, 1.5 A, Case Type: DO-41



EL1Z		1.5	25	200	-	20	0.98	1.5	100	50 ⁽²⁾
EL1		1.5	25	400	-	20	1.30	1.5	10	100 ⁽²⁾

SFO1/SSOA Series, 1.5 A, Case Type: DO-41/SMA



SFO1	SSOA	1.5	55	50	5.0	60	0.95	1.5	5.0	35 ⁽¹⁾
SFO2	SSOB	1.5	55	100	5.0	60	0.95	1.5	5.0	35 ⁽¹⁾
SFO3	SSOC	1.5	55	150	5.0	60	0.95	1.5	5.0	35 ⁽¹⁾
SFO4	SSOD	1.5	55	200	5.0	60	0.95	1.5	5.0	35 ⁽¹⁾
SFO5	SSOE	1.5	55	300	5.0	60	1.70	1.5	5.0	35 ⁽¹⁾
SFO6	SSOG	1.5	55	400	5.0	60	1.70	1.5	5.0	35 ⁽¹⁾
SFO7	SSOJ	1.5	55	600	5.0	60	1.70	1.5	5.0	35 ⁽¹⁾
SFO8	SSOK	1.5	55	800	5.0	60	4.00	1.5	20	35 ⁽¹⁾
SFO9	SSOM	1.5	55	1000	5.0	60	4.00	1.5	20	35 ⁽¹⁾

EGP20A Series, 2 A, Case Type: D2



EGP20A		2.0	55	50	-	75	0.95	2.0	5.0	50 ⁽¹⁾
EGP20B		2.0	55	100	-	75	0.95	2.0	5.0	50 ⁽¹⁾
EGP20C		2.0	55	150	-	75	0.95	2.0	5.0	50 ⁽¹⁾
EGP20D		2.0	55	200	-	75	0.95	2.0	5.0	50 ⁽¹⁾

UG2A-D Series, 2 A, Case Type: DO-41



UG2A		2.0	50	50	-	80	0.95	2.0	5.0	15 ⁽¹⁾
UG2B		2.0	50	100	-	80	0.95	2.0	5.0	15 ⁽¹⁾
UG2C		2.0	50	150	-	80	0.95	2.0	5.0	15 ⁽¹⁾
UG2D		2.0	50	200	-	80	0.95	2.0	5.0	15 ⁽¹⁾

Notes:

- (1) Reverse Recovery test conditions : I_F = 0.5 A, I_R = 1 A, I_{rr} = 0.25 A
- (2) Reverse Recovery test conditions : I_F = 100 mA, I_R = 100 mA

Super Fast Rectifier Diodes

The plastic material carries U/L recognition 94V-0.

Type No.	Max. Average Forward Rectified Current		Max. Repetitive Peak Reverse Voltage	Max. Repetitive Peak Forward Current	Max. Forward Surge Current	Max. Forward Voltage Drop at Ta=25°C		Max. Reverse Current at Ta=25°C	Max. Reverse Recovery Time	
	I _{F(AV)}	@ Ta	V _{RRM}	I _{FRM}	I _{FSM}	V _F	@ I _F	I _R	T _{rr}	
Axial Lead	SMD	(A)	(°C)	(V)	(A)	(A)	(V)	(A)	(μA)	(ns)

SF21/SS2A Series, 2 A, Case Type: D2/SMB



Type No.	Case Type	I _{F(AV)}	@ Ta	V _{RRM}	I _{FRM}	I _{FSM}	V _F	@ I _F	I _R	T _{rr}
SF21	SS2A	2.0	55	50	10	75	0.95	2.0	5.0	35 ⁽¹⁾
SF22	SS2B	2.0	55	100	10	75	0.95	2.0	5.0	35 ⁽¹⁾
SF23	SS2C	2.0	55	150	10	75	0.95	2.0	5.0	35 ⁽¹⁾
SF24	SS2D	2.0	55	200	10	75	0.95	2.0	5.0	35 ⁽¹⁾
SF25	SS2E	2.0	55	300	10	75	1.70	2.0	5.0	35 ⁽¹⁾
SF26	SS2G	2.0	55	400	10	75	1.70	2.0	5.0	35 ⁽¹⁾
SF27	SS2J	2.0	55	600	10	75	1.70	2.0	5.0	35 ⁽¹⁾
SF28	SS2K	2.0	55	800	10	75	4.00	2.0	20	35 ⁽¹⁾
SF29	SS2M	2.0	55	1000	10	75	4.00	2.0	20	35 ⁽¹⁾

ES2A Series, 2 A, Case Type: SMB



Type No.	Case Type	I _{F(AV)}	@ Ta	V _{RRM}	I _{FRM}	I _{FSM}	V _F	@ I _F	I _R	T _{rr}
ES2A	ES2A	2.0	110(T _L)	50	-	50	0.90	2.0	5.0	20 ⁽¹⁾
ES2B	ES2B	2.0	110(T _L)	100	-	50	0.90	2.0	5.0	20 ⁽¹⁾
ES2C	ES2C	2.0	110(T _L)	150	-	50	0.90	2.0	5.0	20 ⁽¹⁾
ES2D	ES2D	2.0	110(T _L)	200	-	50	0.90	2.0	5.0	20 ⁽¹⁾

* For SMA package add suffix "A" e.g. ES2AA, ES2BA...

SFT1/SSTA Series, 2.5 A, Case Type: D2A/SMB



Type No.	Case Type	I _{F(AV)}	@ Ta	V _{RRM}	I _{FRM}	I _{FSM}	V _F	@ I _F	I _R	T _{rr}
SFT1	SSTA	2.5	55	50	10	100	0.95	2.5	5.0	35 ⁽¹⁾
SFT2	SSTB	2.5	55	100	10	100	0.95	2.5	5.0	35 ⁽¹⁾
SFT3	SSTC	2.5	55	150	10	100	0.95	2.5	5.0	35 ⁽¹⁾
SFT4	SSTD	2.5	55	200	10	100	0.95	2.5	5.0	35 ⁽¹⁾
SFT5	SSTE	2.5	55	300	10	100	1.70	2.5	5.0	35 ⁽¹⁾
SFT6	SSTG	2.5	55	400	10	100	1.70	2.5	5.0	35 ⁽¹⁾
SFT7	SSTJ	2.5	55	600	10	100	1.70	2.5	5.0	35 ⁽¹⁾
SFT8	SSTK	2.5	55	800	10	100	4.00	2.5	5.0	35 ⁽¹⁾
SFT9	SSTM	2.5	55	1000	10	100	4.00	2.5	5.0	35 ⁽¹⁾

1N5807/1N5807US Series, 3.0 A, Case Type: D2A/SMB



Type No.	Case Type	I _{F(AV)}	@ Ta	V _{RRM}	I _{FRM}	I _{FSM}	V _F	@ I _F	I _R	T _{rr}
1N5807	1N5807US	3.0	55	50	-	125	0.875	4	5	30 ⁽²⁾
1N5809	1N5809US	3.0	55	100	-	125	0.875	4	5	30 ⁽²⁾
1N5811	1N5811US	3.0	55	150	-	125	0.875	4	5	30 ⁽²⁾

UF5404 Series, 3 A, Case Type: DO-201AD



Type No.	Case Type	I _{F(AV)}	@ Ta	V _{RRM}	I _{FRM}	I _{FSM}	V _F	@ I _F	I _R	T _{rr}
UF5404	UF5404	3.0	55	300	-	150	1.00	3.0	10	50 ⁽¹⁾
UF5405	UF5405	3.0	55	400	-	150	1.00	3.0	10	50 ⁽¹⁾
UF5406	UF5406	3.0	55	600	-	150	1.70	3.0	10	75 ⁽¹⁾
UF5407	UF5407	3.0	55	800	-	150	1.70	3.0	10	75 ⁽¹⁾
UF5408	UF5408	3.0	55	1000	-	150	1.70	3.0	10	75 ⁽¹⁾

Notes:

- (1) Reverse Recovery test conditions : I_F = 0.5 A, I_R = 1 A, I_{rr} = 0.25 A
- (2) Reverse Recovery test conditions : I_F = 100 mA, I_R = 100 mA



Super Fast Rectifier Diodes

The plastic material carries U/L recognition 94V-0.

Type No.	Max. Average Forward Rectified Current		Max. Repetitive Peak Reverse Voltage	Max. Repetitive Peak Forward Current	Max. Forward Surge Current	Max. Forward Voltage Drop at Ta=25°C		Max. Reverse Current at Ta=25°C	Max. Reverse Recovery Time
	I _{F(AV)}	@ Ta	V _{RRM}	I _{FRM}	I _{FSM}	V _F	@ I _F	I _R	T _{rr}
Axial Lead	SMD	(A)	(°C)	(V)	(A)	(V)	(A)	(μA)	(ns)

ES3A-M Series, 3 A, Case Type: SMC



Type No.	Max. Average Forward Rectified Current (A)	@ Ta (°C)	Max. Repetitive Peak Reverse Voltage (V)	Max. Repetitive Peak Forward Current (A)	Max. Forward Surge Current (A)	Max. Forward Voltage Drop (V)	@ I _F (A)	Max. Reverse Current (μA)	Max. Reverse Recovery Time (ns)
ES3A	3.0	55	50	-	100	0.95	3.0	10	35 ⁽¹⁾
ES3B	3.0	55	100	-	100	0.95	3.0	10	35 ⁽¹⁾
ES3C	3.0	55	150	-	100	0.95	3.0	10	35 ⁽¹⁾
ES3D	3.0	55	200	-	100	0.95	3.0	10	35 ⁽¹⁾
ES3E	3.0	55	300	-	100	1.30	3.0	10	35 ⁽¹⁾
ES3G	3.0	55	400	-	100	1.30	3.0	10	35 ⁽¹⁾
ES3J	3.0	55	600	-	100	1.70	3.0	10	35 ⁽¹⁾
ES3K	3.0	55	800	-	100	1.70	3.0	10	35 ⁽¹⁾
ES3M	3.0	55	1000	-	100	1.70	3.0	10	35 ⁽¹⁾

SF31/SS3A Series, 3 A, Case Type: DO-201AD/SMC



Type No.	Max. Average Forward Rectified Current (A)	@ Ta (°C)	Max. Repetitive Peak Reverse Voltage (V)	Max. Repetitive Peak Forward Current (A)	Max. Forward Surge Current (A)	Max. Forward Voltage Drop (V)	@ I _F (A)	Max. Reverse Current (μA)	Max. Reverse Recovery Time (ns)	
SF31	SS3A	3.0	55	50	15	125	0.95	3.0	10	35 ⁽¹⁾
SF32	SS3B	3.0	55	100	15	125	0.95	3.0	10	35 ⁽¹⁾
SF33	SS3C	3.0	55	150	15	125	0.95	3.0	10	35 ⁽¹⁾
SF34	SS3D	3.0	55	200	15	125	0.95	3.0	10	35 ⁽¹⁾
SF35	SS3E	3.0	55	300	15	125	1.70	3.0	10	35 ⁽¹⁾
SF36	SS3G	3.0	55	400	15	125	1.70	3.0	10	35 ⁽¹⁾
SF37	SS3J	3.0	55	600	15	125	1.70	3.0	10	35 ⁽¹⁾
SF38	SS3K	3.0	55	800	15	125	4.00	3.0	10	35 ⁽¹⁾
SF39	SS3M	3.0	55	1000	15	125	4.00	3.0	10	35 ⁽¹⁾

SF51/SS5A Series, 5 A, Case Type: DO-201AD/SMC



Type No.	Max. Average Forward Rectified Current (A)	@ Ta (°C)	Max. Repetitive Peak Reverse Voltage (V)	Max. Repetitive Peak Forward Current (A)	Max. Forward Surge Current (A)	Max. Forward Voltage Drop (V)	@ I _F (A)	Max. Reverse Current (μA)	Max. Reverse Recovery Time (ns)	
SF51	SS5A	5.0	55	50	20	135	0.95	5.0	10	35 ⁽¹⁾
SF52	SS5B	5.0	55	100	20	135	0.95	5.0	10	35 ⁽¹⁾
SF53	SS5C	5.0	55	150	20	135	0.95	5.0	10	35 ⁽¹⁾
SF54	SS5D	5.0	55	200	20	135	0.95	5.0	10	35 ⁽¹⁾
SF55	SS5E	5.0	55	300	20	135	1.70	5.0	10	35 ⁽¹⁾
SF56	SS5G	5.0	55	400	20	135	1.70	5.0	10	35 ⁽¹⁾
SF57	SS5J	5.0	55	600	20	135	1.70	5.0	10	35 ⁽¹⁾
SF58	SS5K	5.0	55	800	20	135	4.00	5.0	10	35 ⁽¹⁾
SF59	SS5M	5.0	55	1000	20	135	4.00	5.0	10	35 ⁽¹⁾

SF61 Series, 6 A, Case Type: D6



Type No.	Max. Average Forward Rectified Current (A)	@ Ta (°C)	Max. Repetitive Peak Reverse Voltage (V)	Max. Repetitive Peak Forward Current (A)	Max. Forward Surge Current (A)	Max. Forward Voltage Drop (V)	@ I _F (A)	Max. Reverse Current (μA)	Max. Reverse Recovery Time (ns)	
SF61		6.0	55	50	25	150	0.95	6.0	5.0	35 ⁽¹⁾
SF62		6.0	55	100	25	150	0.95	6.0	5.0	35 ⁽¹⁾
SF63		6.0	55	150	25	150	0.95	6.0	5.0	35 ⁽¹⁾
SF64		6.0	55	200	25	150	0.95	6.0	5.0	35 ⁽¹⁾
SF65		6.0	55	300	25	150	1.70	6.0	5.0	35 ⁽¹⁾
SF66		6.0	55	400	25	150	1.70	6.0	5.0	35 ⁽¹⁾
SF67		6.0	55	600	25	150	1.70	6.0	5.0	35 ⁽¹⁾
SF68		6.0	55	800	25	150	4.00	6.0	5.0	35 ⁽¹⁾
SF69		6.0	55	1000	25	150	4.00	6.0	5.0	35 ⁽¹⁾

Note :

(1) Reverse Recovery test conditions : I_F = 0.5 A, I_R = 1 A, I_{rr} = 0.25 A



Super Fast Rectifier Diodes

The plastic material carries U/L recognition 94V-0.

Type No.	Max. Average Forward Rectified Current		Max. Repetitive Peak Reverse Voltage	Max. Repetitive Peak Forward Current	Max. Forward Surge Current	Max. Forward Voltage Drop at Ta=25°C		Max. Reverse Current at Ta=25°C	Max. Reverse Recovery Time
	I _{F(AV)}	@ Ta	V _{RRM}	I _{FRM}	I _{FSM}	V _F	@ I _F	I _R	T _{rr} ⁽¹⁾
Axial Lead	(A)	(°C)	(V)	(A)	(A)	(V)	(A)	(μA)	(ns)

FES8AT Series, 8 A, Case Type: TO-220AC



FES8AT ⁽²⁾	8.0	100(Tc)	50	-	125	0.95	8.0	10	35 ⁽¹⁾
FES8BT ⁽²⁾	8.0	100(Tc)	100	-	125	0.95	8.0	10	35 ⁽¹⁾
FES8CT ⁽²⁾	8.0	100(Tc)	150	-	125	0.95	8.0	10	35 ⁽¹⁾
FES8DT ⁽²⁾	8.0	100(Tc)	200	-	125	0.95	8.0	10	35 ⁽¹⁾
FES8FT ⁽²⁾	8.0	100(Tc)	300	-	125	1.30	8.0	10	50 ⁽¹⁾
FES8GT ⁽²⁾	8.0	100(Tc)	400	-	125	1.30	8.0	10	50 ⁽¹⁾
FES8HT ⁽²⁾	8.0	100(Tc)	500	-	125	1.50	8.0	10	50 ⁽¹⁾
FES8JT ⁽²⁾	8.0	100(Tc)	600	-	125	1.50	8.0	10	50 ⁽¹⁾

FES16AT Series, 16 A, Case Type: TO-220AC

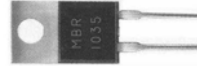

FES16AT ⁽²⁾	16	100(Tc)	50	-	250	0.95	16	10	35 ⁽¹⁾
FES16BT ⁽²⁾	16	100(Tc)	100	-	250	0.95	16	10	35 ⁽¹⁾
FES16CT ⁽²⁾	16	100(Tc)	150	-	250	0.95	16	10	35 ⁽¹⁾
FES16DT ⁽²⁾	16	100(Tc)	200	-	250	0.95	16	10	35 ⁽¹⁾
FES16FT ⁽²⁾	16	100(Tc)	300	-	250	1.30	16	10	50 ⁽¹⁾
FES16GT ⁽²⁾	16	100(Tc)	400	-	250	1.30	16	10	50 ⁽¹⁾
FES16HT ⁽²⁾	16	100(Tc)	500	-	250	1.50	16	10	50 ⁽¹⁾
FES16JT ⁽²⁾	16	100(Tc)	600	-	250	1.50	16	10	50 ⁽¹⁾

FEP16AT Series, 16 A, Case Type: TO-220AB



FEP16AT	16	100(Tc)	50	-	125	0.95	16	10	35
FEP16BT	16	100(Tc)	100	-	125	0.95	16	10	35
FEP16CT	16	100(Tc)	150	-	125	0.95	16	10	35
FEP16DT	16	100(Tc)	200	-	125	0.95	16	10	35
FEP16FT	16	100(Tc)	300	-	125	1.30	16	10	50
FEP16GT	16	100(Tc)	400	-	125	1.30	16	10	50
FEP16HT	16	100(Tc)	500	-	125	1.50	16	10	50
FEP16JT	16	100(Tc)	600	-	125	1.50	16	10	50

FEP30AP Series, 30 A, Case Type: TO-247AD



FEP30AP	30	100(Tc)	50	-	300	0.95	30	10	35
FEP30BP	30	100(Tc)	100	-	300	0.95	30	10	35
FEP30CP	30	100(Tc)	150	-	300	0.95	30	10	35
FEP30DP	30	100(Tc)	200	-	300	0.95	30	10	35
FEP30FP	30	100(Tc)	300	-	300	1.30	30	10	50
FEP30GP	30	100(Tc)	400	-	300	1.30	30	10	50
FEP30HP	30	100(Tc)	500	-	300	1.50	30	10	50
FEP30JP	30	100(Tc)	600	-	300	1.50	30	10	50

Notes :

(1) Reverse Recovery test conditions : I_F = 0.5 A, I_R = 1 A, I_{rr} = 0.25 A

(2) For wire leads (case type ITO-220AC) add suffix "F" e.g. FESF8AT, FESF8BT, ..., FESF8JT and FESF16AT, FESF16BT, ..., FESF16JT



Super Fast Glass Passivated Rectifier Diodes

The plastic material carries U/L recognition 94V-0.

Type No.	Max. Average Forward Rectified Current		Max. Repetitive Peak Reverse Voltage	Max. Repetitive Peak Forward Current	Max. Surge Forward Current	Max. Forward Voltage Drop at Ta=25°C		Max. Reverse Current at Ta=25°C	Max. Reverse Recovery Time	
	I _{F(AV)}	@ Ta	V _{RRM}	I _{FRM}	I _{FSM}	V _F	@ I _F	I _R	T _{rr} ⁽¹⁾	
Axial Lead	SMD	(A)	(°C)	(V)	(A)	(A)	(V)	(A)	(μA)	(ns)

LMS1A/SMS1A Series, 1 A, Case Type: M1A/SOD-123FL



Type No.	Series	I _{F(AV)}	@ Ta	V _{RRM}	I _{FRM}	I _{FSM}	V _F	@ I _F	I _R	T _{rr} ⁽¹⁾
LMS1A	SMS1A	1.0	50	50	-	30	0.95	1.0	5.0	35
LMS1B	SMS1B	1.0	50	100	-	30	0.95	1.0	5.0	35
LMS1D	SMS1D	1.0	50	200	-	30	0.95	1.0	5.0	35
LMS1G	SMS1G	1.0	50	400	-	30	1.7	1.0	5.0	35
LMS1J	SMS1J	1.0	50	600	-	30	1.7	1.0	5.0	35
LMS1K	SMS1K	1.0	50	800	-	30	4.0	1.0	10	35
LMS1M	SMS1M	1.0	50	1000	-	30	4.0	1.0	10	35

SF11G Series, 1 A, Case Type: DO-41



Type No.	Series	I _{F(AV)}	@ Ta	V _{RRM}	I _{FRM}	I _{FSM}	V _F	@ I _F	I _R	T _{rr} ⁽¹⁾
SF11G		1.0	55	50	-	30	0.95	1.0	5.0	35
SF12G		1.0	55	100	-	30	0.95	1.0	5.0	35
SF13G		1.0	55	150	-	30	0.95	1.0	5.0	35
SF14G		1.0	55	200	-	30	0.95	1.0	5.0	35
SF15G		1.0	55	300	-	30	1.7	1.0	5.0	35
SF16G		1.0	55	400	-	30	1.7	1.0	5.0	35
SF17G		1.0	55	600	-	30	1.7	1.0	5.0	35
SF18G		1.0	55	800	-	30	4.0	1.0	10	35
SF19G		1.0	55	1000	-	30	4.0	1.0	10	35

1N5802/1N5802US Series, 2.5 A, Case Type: DO-41



Type No.	Series	I _{F(AV)}	@ Ta	V _{RRM}	I _{FRM}	I _{FSM}	V _F	@ I _F	I _R	T _{rr} ⁽¹⁾
1N5802	1N5802US	2.5	75 (T _L)	50	-	35	0.875	1.0	1.0	25
1N5803	1N5803US	2.5	75 (T _L)	75	-	35	0.875	1.0	1.0	25
1N5804	1N5804US	2.5	75 (T _L)	100	-	35	0.875	1.0	1.0	25
1N5805	1N5805US	2.5	75 (T _L)	125	-	35	0.875	1.0	1.0	25
1N5806	1N5806US	2.5	75 (T _L)	150	-	35	0.875	1.0	1.0	25

Note :

(1) Reverse Recovery test conditions : I_F = 0.5 A, I_R = 1 A, I_{rr} = 0.25 A



Schottky Barrier Rectifiers

The plastic material carries U/L recognition 94V-O.

Type No.		Max. Average Forward Rectified Current		Max. Repetitive Peak Reverse Voltage	Max. Repetitive Peak Forward Current	Max. Forward Surge Current	Max. Forward Voltage Drop at Ta=25°C		Max. Reverse Current at Ta=25°C
		IF(AV) @ TL		VRRM	IFRM	IFSM	VF @ IF		IR
Axial Lead	SMD	(A)	(°C)	(V)	(A)	(A)	(V)	(A)	(mA)

AK03 Series, 0.7 - 1 A, Case Type: DO-41



AK03		1.0	25	30	-	25	0.55	1.0	1.0
AK04		1.0	25	40	-	25	0.55	1.0	1.0
AK06		0.7	40	60	-	10	0.62	0.7	1.0
AK09		0.7	35	90	-	10	0.81	0.7	1.0

1N5817/SKN7 Series, 1 A, Case Type: DO-41/SMA



1N5817	SKN7	1.0	90	20	5.0	25	0.45	1.0	1.0
1N5818	SKN8	1.0	90	30	5.0	25	0.55	1.0	1.0
1N5819	SKN9	1.0	90	40	5.0	25	0.60	1.0	1.0

LL5817 Series, 1 A, Case Type: MELF(Plastic)



	LL5817	1.0	90	20	5.0	25	0.45	1.0	1.0
	LL5818	1.0	90	30	5.0	25	0.55	1.0	1.0
	LL5819	1.0	90	40	5.0	25	0.60	1.0	1.0

1S20/SMK1A Series, 1.0 A, Case Type: M1A/SOD-123FL



1S20	SMK1A	1.0	75	20	-	35	0.55	1.0	1.0
1S30	SMK1B	1.0	75	30	-	35	0.55	1.0	1.0
1S40	SMK1D	1.0	75	40	-	35	0.55	1.0	1.0
1S50	SMK1G	1.0	100	50	-	35	0.70	1.0	1.0
1S60	SMK1J	1.0	100	60	-	35	0.70	1.0	1.0
1S80	SMK1K	1.0	100	80	-	35	0.85	1.0	1.0
1SB0	SMK1M	1.0	100	100	-	35	0.85	1.0	1.0

ERA Series, 1 A, Case Type: DO-41



ERA81-004		1.0	25	40	-	50	0.55	1.0	2.0
ERA83-004		1.0	115	40	-	50	0.55	1.0	2.0
ERA83-006		1.0	111	60	-	30	0.58	1.0	2.0
ERA84-009		1.0	25	90	-	60	0.90	1.0	1.0

SB120/SK12 Series, 1 A, Case Type: DO-41/SMA



SB120	SK12	1.0	75	20	5.0	40	0.50	1.0	0.5
SB130	SK13	1.0	75	30	5.0	40	0.50	1.0	0.5
SB140	SK14	1.0	75	40	5.0	40	0.50	1.0	0.5
SB150	SK15	1.0	100	50	5.0	40	0.70	1.0	0.5
SB160	SK16	1.0	100	60	5.0	40	0.70	1.0	0.5
SB170	SK17	1.0	100	70	5.0	40	0.70	1.0	0.5
SB180	SK18	1.0	100	80	5.0	40	0.79	1.0	0.5
SB190	SK19	1.0	100	90	5.0	40	0.79	1.0	0.5
SB1B0	SK1B	1.0	100	100	5.0	40	0.79	1.0	0.5



Schottky Barrier Rectifiers

The plastic material carries U/L recognition 94V-O.

Type No.		Max. Average Forward Rectified Current		Max. Repetitive Peak Reverse Voltage	Max. Repetitive Peak Forward Current	Max. Forward Surge Current	Max. Forward Voltage Drop at Ta=25°C		Max. Reverse Current at Ta=25°C
		IF(AV) @ TL	(A) (°C)	VRRM (V)	IFRM (A)	IFSM (A)	VF @ IF (V)	(A)	IR (mA)
Axial Lead	SMD	(A)	(°C)	(V)	(A)	(A)	(V)	(A)	(mA)

MBR150 Series, 1 A, Case Type: DO-41



MBR150		1.0	55 (Ta)	50	-	25	0.75	1.0	0.5
MBR160		1.0	55 (Ta)	60	-	25	0.75	1.0	0.5

EK Series, 1 - 1.5 A, Case Type: DO-41



EK03		1.0	25	30	-	25	0.55	1.0	1.0
EK04		1.0	25	40	-	25	0.55	1.0	1.0
EK13		1.5	40	30	-	40	0.55	2.0	5.0
EK14		1.5	40	40	-	40	0.55	2.0	5.0
EK16		1.5	40	60	-	25	0.62	1.5	1.0
EK19		1.5	35	90	-	40	0.81	1.5	2.0

11DQ03 Series, 1.1 A, Case Type: DO-41



11DQ03		1.1	75 (Tc)	30	-	42	0.55	1.1	6.0
11DQ04		1.1	75 (Tc)	40	-	42	0.55	1.1	6.0
11DQ05		1.1	84 (Tc)	50	-	26	0.58	1.1	11
11DQ06		1.1	84 (Tc)	60	-	26	0.58	1.1	11
11DQ09		1.1	75 (Tc)	90	-	42	0.85	1.1	0.5
11DQ10		1.1	75 (Tc)	100	-	42	0.85	1.1	1.0

10MQ Series, 1.5 A, Case Type: SMA



	10MQ040N	1.5	123	40	-	30	0.62	1.5	0.5
	10MQ100N	1.5	126	100	-	30	0.85	1.5	0.1

SL12 Series, 1.5 A, Case Type: SMA



	SL12	1.5	105	20	-	50	0.445	1.0	0.2
	SL13	1.5	105	30	-	50	0.445	1.0	0.2

RK13 Series, 1.5 - 1.7 A, Case Type: D2



RK13		1.7	75	30	15	50	0.55	1.7	5.1
RK14		1.7	75	40	15	50	0.55	1.7	5.1
RK16		1.5	75	60	15	50	0.62	1.5	1.0
RK19		1.5	75	90	15	50	0.81	1.5	2.0

21DQ09 Series, 1.7 A, Case Type: DO-41



21DQ09		1.7	47	90	-	70	0.85	2.0	1.0
21DQ10		1.7	43	100	-	70	0.85	2.0	1.0



Schottky Barrier Rectifiers

The plastic material carries U/L recognition 94V-O.

Type No.		Max. Average Forward Rectified Current		Max. Repetitive Peak Reverse Voltage	Max. Repetitive Peak Forward Current	Max. Forward Surge Current	Max. Forward Voltage Drop at Ta=25°C		Max. Reverse Current at Ta=25°C
		IF(AV) @ TL		VRRM	IFRM	IFSM	VF @ IF		IR
Axial Lead	SMD	(A)	(°C)	(V)	(A)	(A)	(V)	(A)	(mA)

SBO20 Series, 1.5 A, Case Type: DO-41



SBO20		1.5	75	20	-	50	0.50	1.5	0.5
SBO30		1.5	75	30	-	50	0.50	1.5	0.5
SBO40		1.5	75	40	-	50	0.50	1.5	0.5
SBO50		1.5	100	50	-	50	0.70	1.5	0.5
SBO60		1.5	100	60	-	50	0.70	1.5	0.5
SBO70		1.5	100	70	-	50	0.70	1.5	0.5
SBO80		1.5	100	80	-	50	0.79	1.5	0.5
SBO90		1.5	100	90	-	50	0.79	1.5	0.5
SBOB0		1.5	100	100	-	50	0.79	1.5	0.5

ERB81 Series, 2.0 A, Case Type: D2



ERB81-004		2.0	25 (Ta)	40	-	100	0.55	2.0	5.0
ERB83-004		2.0	25 (Ta)	40	-	100	0.55	2.0	5.0
ERB83-006		2.0	104	60	-	60	0.58	2.0	5.0
ERB84-009		2.0	25 (Ta)	90	-	60	0.90	2.0	2.0

SB220/SK22 Series, 2.0 A, Case Type: D2/SMB



SB220	SK22	2.0	75	20	10	60	0.50	2.0	0.5
SB230	SK23	2.0	75	30	10	60	0.50	2.0	0.5
SB240	SK24	2.0	75	40	10	60	0.50	2.0	0.5
SB250	SK25	2.0	100	50	10	60	0.74	2.0	0.5
SB260	SK26	2.0	100	60	10	60	0.74	2.0	0.5
SB270	SK27	2.0	100	70	10	60	0.74	2.0	0.5
SB280	SK28	2.0	100	80	10	60	0.79	2.0	0.5
SB290	SK29	2.0	100	90	10	60	0.79	2.0	0.5
SB2B0	SK2B	2.0	100	100	10	60	0.79	2.0	0.5

Also available in Axial DO-41 and SMD SMA Case Types. Use suffix "S" to order (e.g. SB220S, SK22S)

SR220 - SR2100 Series, 2.0 A, Case Type: DO-41



SR220		2.0	40	20	-	50	0.55	2.0	2.0
SR230		2.0	40	30	-	50	0.55	2.0	2.0
SR240		2.0	40	40	-	50	0.55	2.0	2.0
SR250		2.0	60	50	-	50	0.70	2.0	2.0
SR260		2.0	60	60	-	50	0.70	2.0	2.0
SR290		2.0	60	90	-	50	0.85	2.0	2.0
SR2100		2.0	60	100	-	50	0.85	2.0	2.0

RK33 Series, 2.0 - 2.5 A, Case Type: D2A



RK33		2.5	75	30	15	50	0.55	2.5	5.0
RK34		2.5	75	40	15	50	0.55	2.5	5.0
RK36		2.0	75	60	15	50	0.62	2.0	2.0
RK39		2.0	75	90	15	50	0.81	2.0	3.0



Schottky Barrier Rectifiers

The plastic material carries U/L recognition 94V-O.

Type No.		Max. Average Forward Rectified Current		Max. Repetitive Peak Reverse Voltage	Max. Repetitive Peak Forward Current	Max. Forward Surge Current	Max. Forward Voltage Drop at Ta=25°C		Max. Reverse Current at Ta=25°C
		IF(AV) @ TL	(A) (°C)	VRRM (V)	IFRM (A)	IFSM (A)	VF @ IF (V) (A)	IR (mA)	

SBT20 Series, 2.5 A, Case Type: D2A



SBT20		2.5	75	20	-	50	0.50	1.5	0.5
SBT30		2.5	75	30	-	50	0.50	1.5	0.5
SBT40		2.5	75	40	-	50	0.50	1.5	0.5
SBT50		2.5	100	50	-	50	0.74	1.5	0.5
SBT60		2.5	100	60	-	50	0.74	1.5	0.5
SBT70		2.5	100	70	-	50	0.74	1.5	0.5
SBT80		2.5	100	80	-	50	0.79	1.5	0.5
SBT90		2.5	100	90	-	50	0.79	1.5	0.5
SBTB0		2.5	100	100	-	50	0.79	1.5	0.5

ERC Series, 2.6 - 3.0 A, Case Type: DO-201AD



ERC81-004		2.6	25	40	-	120	0.55	3.0	5.0
ERC81-006		3.0	104	60	-	80	0.58	3.0	5.0
ERC84-009		3.0	85	90	-	120	0.80	3.0	0.5

1N5820/SKN0 Series, 3 A, Case Type: DO-201AD/SMC



1N5820	SKN0	3.0	95	20	15	80	0.475	3.0	2.0
1N5821	SKN1	3.0	95	30	15	80	0.500	3.0	2.0
1N5822	SKN2	3.0	95	40	15	80	0.525	3.0	2.0

Also available in Axial D2A and SMD SMB Case Types. Use suffix "S" to order (e.g. 1N5820S, SKN0S)

SB320/SK32 Series, 3 A, Case Type: DO-201AD/SMC



SB320	SK32	3.0	75	20	15	80	0.50	3.0	0.5
SB330	SK33	3.0	75	30	15	80	0.50	3.0	0.5
SB340	SK34	3.0	75	40	15	80	0.50	3.0	0.5
SB350	SK35	3.0	100	50	15	80	0.74	3.0	0.5
SB360	SK36	3.0	100	60	15	80	0.74	3.0	0.5
SB370	SK37	3.0	100	70	15	80	0.74	3.0	0.5
SB380	SK38	3.0	100	80	15	80	0.79	3.0	0.5
SB390	SK39	3.0	100	90	15	80	0.79	3.0	0.5
SB3B0	SK3B	3.0	100	100	15	80	0.79	3.0	0.5

Also available in Axial D2A and SMD SMB Case Types. Use suffix "S" to order (e.g. SB320S, SK32S), SMA Case Types. Use suffix "A" to order (e.g. SK32A).

MBR320 Series, 3 A, Case Type: DO-201AD



MBR320		3.0	65 (Ta)	20	-	80	0.60	3.0	0.6
MBR330		3.0	65 (Ta)	30	-	80	0.60	3.0	0.6
MBR340		3.0	65 (Ta)	40	-	80	0.60	3.0	0.6
MBR350		3.0	65 (Ta)	50	-	80	0.74	3.0	0.6
MBR360		3.0	65 (Ta)	60	-	80	0.74	3.0	0.6



Schottky Barrier Rectifiers

The plastic material carries U/L recognition 94V-O.

Type No.		Max. Average Forward Rectified Current		Max. Repetitive Peak Reverse Voltage	Max. Repetitive Peak Forward Current	Max. Forward Surge Current	Max. Forward Voltage Drop at Ta=25°C		Max. Reverse Current at Ta=25°C
		IF(AV) @ TL	(A) (°C)	VRRM (V)	IFRM (A)	IFSM (A)	VF @ IF (V)	(A)	IR (mA)

RK43 Series, 3.0 - 3.5 A, Case Type: DO-201AD



RK43		3.0	109	30	-	80	0.55	3.0	5.0
RK44		3.0	109	40	-	80	0.55	3.0	5.0
RK46		3.5	109	60	-	70	0.62	3.5	3.0
RK49		3.5	109	90	-	60	0.81	3.5	5.0

31DQ03 Series, 3.3 A, Case Type: DO-201AD



31DQ03		3.3	48 (Tc)	30	-	120	0.55	3.0	3.0
31DQ04		3.3	48 (Tc)	40	-	120	0.55	3.0	3.0
31DQ09		3.3	53 (Tc)	90	-	34	0.85	3.5	1.0
31DQ10		3.3	53 (Tc)	100	-	34	0.85	3.5	1.0

SB520/SK52 Series, 5 A, Case Type: DO-201AD/SMC



SB520	SK52	5.0	60	20	25	150	0.55	5.0	0.5
SB530	SK53	5.0	60	30	25	150	0.55	5.0	0.5
SB540	SK54	5.0	60	40	25	150	0.55	5.0	0.5
SB550	SK55	5.0	80	50	25	150	0.67	5.0	0.5
SB560	SK56	5.0	80	60	25	150	0.67	5.0	0.5
SB570	SK57	5.0	80	70	25	150	0.67	5.0	0.5
SB580	SK58	5.0	80	80	25	150	0.79	5.0	0.5
SB590	SK59	5.0	80	90	25	150	0.79	5.0	0.5
SB5B0	SK5B	5.0	80	100	25	150	0.79	5.0	0.5

Also available in Axial D2A and SMD SMB Case Types. Use suffix "S" to order (e.g. SB520S, SK52S)

SR520 Series, 5.0 A, Case Type: DO-201AD



SR520		5.0	60	20	-	150	0.57	5.0	10
SR530		5.0	60	30	-	120	0.57	5.0	10
SR540		5.0	60	40	-	120	0.57	5.0	10
SR550		5.0	85	50	-	120	0.70	5.0	10
SR560		5.0	85	60	-	120	0.70	5.0	10

MBR735 Series, 7.5 A, Case Type: TO-220AC



MBR735		7.5	105(Tc)	35	-	150	-	-	0.1
MBR745		7.5	105(Tc)	45	-	150	-	-	0.1
MBR750		7.5	105(Tc)	50	-	150	0.75	7.5	0.5
MBR760		7.5	105(Tc)	60	-	150	0.75	7.5	0.5

SBL1030 Series, 10 A, Case Type: TO-220AC



SBL1030		10	110(Tc)	30	-	250	0.6	10	1.0
SBL1040		10	110(Tc)	40	-	250	0.6	10	1.0



Schottky Barrier Rectifiers

The plastic material carries U/L recognition 94V-O.

Type No.		Max. Average Forward Rectified Current		Max. Repetitive Peak Reverse Voltage	Max. Repetitive Peak Forward Current	Max. Forward Surge Current	Max. Forward Voltage Drop at Ta=25°C		Max. Reverse Current at Ta=25°C
		IF(AV) @ TL	(A) (°C)	VRRM (V)	IFRM (A)	IFSM (A)	VF @ IF (V)	(A)	IR (mA)
Axial Lead	SMD	(A)	(°C)	(V)	(A)	(A)	(V)	(A)	(mA)

MBR1035 Series, 10 A, Case Type: TO-220AC



MBR1035		10	125(Tc)	35	-	150	0.84	10	0.10
MBR1045		10	125(Tc)	45	-	150	0.84	10	0.10
MBR1050		10	125(Tc)	50	-	150	0.80	10	0.15
MBR1060		10	125(Tc)	60	-	150	0.80	10	0.15

SBL1030CT Series, 10 - 16 A, Case Type: TO-220AB

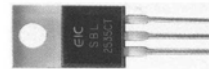

SBL1030CT		10	95(Tc)	30	-	250	0.55	5	0.5
SBL1040CT		10	95(Tc)	40	-	250	0.55	5	0.5
SBL1630CT		16	95(Tc)	30	-	250	0.55	8	0.5
SBL1640CT		16	95(Tc)	40	-	250	0.55	8	0.5

MBR1660ct Series, 16 A, Case Type: TO-220AB



MBR1660CT		16	115(Tc)	60	-	150	0.75	8.0	1.00
MBR16100CT		16	133(Tc)	100	-	150	0.84	16	0.10

MBR1635 Series, 16 A, Case Type: TO-220AC



MBR1635		16	125(Tc)	35	-	150	0.63	16	0.20
MBR1645		16	125(Tc)	45	-	150	0.63	16	0.20
MBR1650		16	125(Tc)	50	-	150	0.75	16	1.00
MBR1660		16	125(Tc)	60	-	150	0.75	16	1.00

MBRF16H35 Series, 16 A, Case Type: ITO-220AC



MBRF16H35		16	130(Tc)	35	-	150	0.66	16	0.10
MBRF16H45		16	130(Tc)	45	-	150	0.66	16	0.10
MBRF16H50		16	130(Tc)	50	-	150	0.73	16	0.10
MBRF16H60		16	130(Tc)	60	-	150	0.73	16	0.10

MBR2035CT Series, 20 A, Case Type: TO-220AB



MBR2035CT		20	135(Tc)	35	-	150	0.57	10	0.10
MBR2045CT		20	135(Tc)	45	-	150	0.57	10	0.10
MBR2050CT		20	135(Tc)	50	-	150	0.8	10	0.15
MBR2060CT		20	135(Tc)	60	-	150	0.8	10	0.15



Schottky Barrier Rectifiers

The plastic material carries U/L recognition 94V-O.

Type No.		Max. Average Forward Rectified Current		Max. Repetitive Peak Reverse Voltage	Max. Repetitive Peak Forward Current	Max. Forward Surge Current	Max. Forward Voltage Drop at Ta=25°C		Max. Reverse Current at Ta=25°C
		IF(AV) @ TL	(A) (°C)	VRRM (V)	IFRM (A)	IFSM (A)	VF @ IF (V)	(A)	IR (mA)
Axial Lead	SMD	(A)	(°C)	(V)	(A)	(A)	(V)	(A)	(mA)

MBR2535CT Series, 30 A, Case Type: TO-220AB

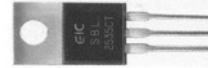

MBR2535CT		30	130(Tc)	35	30	150	0.82	30	0.20
MBR2545CT		30	130(Tc)	45	30	150	0.82	30	0.20
MBR2550CT		30	130(Tc)	50	30	150	0.75	15	1.00
MBR2560CT		30	130(Tc)	60	30	150	0.75	15	1.00

SBL2030PT Series, 20 - 40 A, Case Type: TO-247AD



SBL2030PT		20	105(Tc)	30	-	250	0.55	10	1.0
SBL2040PT		20	105(Tc)	40	-	250	0.55	10	1.0
SBL3030PT		30	100(Tc)	30	-	250	0.55	15	1.0
SBL3040PT		30	100(Tc)	40	-	250	0.55	15	1.0
SBL4030PT		40	100(Tc)	30	-	250	0.58	20	10
SBL4040PT		40	100(Tc)	40	-	250	0.58	20	10

MBR3035PT Series, 30 A, Case Type: TO-247AD



MBR3035PT		30	105(Tc)	35	30	200	0.76	30	1.0
MBR3045PT		30	105(Tc)	45	30	200	0.76	30	1.0
MBR3050PT		30	125(Tc)	50	30	300	0.75	20	5.0
MBR3060PT		30	125(Tc)	60	30	300	0.75	20	5.0

MBR4035PT Series, 40 A, Case Type: TO-247AD



MBR4035PT		40	120(Tc)	35	40	400	0.7	20	10
MBR4045PT		40	120(Tc)	45	40	400	0.7	20	10
MBR4050PT		40	120(Tc)	50	40	400	0.8	20	10
MBR4060PT		40	120(Tc)	60	40	400	0.8	20	10



Schottky Barrier Rectifiers

The plastic material carries U/L recognition 94V-O.

Type No.	Max. Average Forward Rectified Current		Max. Repetitive Peak Reverse Voltage	Max. Repetitive Peak Forward Current	Max. Forward Surge Current	Max. Forward Voltage Drop at Ta=25°C		Max. Reverse Current at Ta=25°C	
	IF(AV) @ TL		VRRM	IFRM	IFSM	VF @ IF		IR	
Axial Lead	SMD	(A)	(°C)	(V)	(A)	(A)	(V)	(A)	(mA)

MBRS1 Series, 1 A, Case Type: SMB



MBRS120T3	1.0	115	20	-	40	0.60	1.0	1.0
MBRS130LT3	1.0	120	30	-	40	0.40	1.0	1.0
MBRS140	1.0	115	40	-	40	0.60	1.0	1.0
MBRS1100	1.0	120	100	-	50	0.75	1.0	0.5

MBRS240LT3G, 2 A, Case Type: SMB



MBRS240LT3G	2.0	100(Tc)	40	-	25	0.43	2.0	2.0
-------------	-----	---------	----	---	----	------	-----	-----

MBRS3200, 3 A, Case Type: SMB



MBRS3200	3.0	120	200	-	100	0.84	3.0	1.0
----------	-----	-----	-----	---	-----	------	-----	-----

MBRS3 Series, 3 A, Case Type: SMC



MBRS330T3	3.0	100	30	-	80	0.50	3.0	2.00
MBRS340T3	3.0	100	40	-	80	0.53	3.0	2.00
MBRS360T3	3.0	137	60	-	125	0.74	3.0	0.15
MBRS3100	3.0	100	100	-	130	0.79	3.0	0.05
MBRS3201	3.0	70(Tc)	200	-	100	0.84	3.0	1.00

MBRS4201, 4 A, Case Type: SMC



MBRS4201	4.0	70	200	-	100	0.86	4.0	1.0
----------	-----	----	-----	---	-----	------	-----	-----

FST10 Series, 10 A, Case Type: TO-220AB



FST10120	10	162	120	-	200	0.82	5	0.1
FST10130	10	162	130	-	200	0.82	5	0.1
FST10150	10	162	150	-	200	0.82	5	0.1
FST10180	10	137	180	-	200	0.84	5	0.1
FST10200	10	137	200	-	200	0.84	5	0.1

MS10 Series, 10 A, Case Type: TO-220AC



MS10180	10	155	180	-	225	0.88	10	0.1
MS10200	10	155	200	-	225	0.88	10	0.1

MS16 Series, 16 A, Case Type: TO-220AC



MS16180	16	146	180	-	250	0.88	16	0.1
MS16200	16	146	200	-	250	0.88	16	0.1



Schottky Barrier Rectifiers

The plastic material carries U/L recognition 94V-O.

Type No.		Max. Average Forward Rectified Current		Max. Repetitive Peak Reverse Voltage	Max. Repetitive Peak Forward Current	Max. Forward Surge Current	Max. Forward Voltage Drop at Ta=25°C		Max. Reverse Current at Ta=25°C
		IF(AV) @ TL		VRRM	IFRM	IFSM	VF @ IF		IR
Axial Lead	SMD	(A)	(°C)	(V)	(A)	(A)	(V)	(A)	(mA)

FST20 Series, 20 A, Case Type: TO-220AB



FST20120		20	157	120	-	225	0.83	10	0.1
FST20130		20	157	130	-	225	0.83	10	0.1
FST20150		20	157	150	-	225	0.83	10	0.1
FST20180		20	155	180	-	225	0.88	10	0.1
FST20200		20	155	200	-	225	0.88	10	0.1

MBR20200CT, 20 A, Case Type: TO-220AB



MBR20200CT		20	125(Tc)	200	20	150	1.00	20	1.0
------------	--	----	---------	-----	----	-----	------	----	-----

* For package ITO-220AB part number MBRF20200CT

MS20 Series, 20 A, Case Type: TO-220AC



MS20180		20	141	180	-	250	0.85	20	0.1
MS20200		20	141	200	-	250	0.85	20	0.1

FST31 Series, 30 A, Case Type: TO-220AB



FST31120		30	153	120	-	250	0.85	15	0.25
FST31130		30	153	130	-	250	0.85	15	0.25
FST31150		30	153	150	-	250	0.85	15	0.25
FST31180		30	150	180	-	250	0.83	15	0.10
FST31200		30	150	200	-	250	0.83	15	0.10



Schottky Barrier Rectifiers

Type No.		Max. Average Forward Rectified Current		Max. Repetitive Peak Reverse Voltage	Max. Repetitive Peak Forward Current	Max. Forward Surge Current	Max. Forward Voltage Drop at Ta=25°C		Max. Reverse Current at Ta=25°C	Max. Power Dissipation
		I _{F(AV)}	@ Ta	V _{RRM}	I _{FRM}	I _{FSM}	V _F	@ I _F	I _R	P _D
Axial Lead	SMD	(mA)	(°C)	(V)	(mA)	(A)	(V)	(mA)	(μA)	(mW)

1N5711/LL5711, Case Type: DO-35 / MiniMELF



1N5711	LL5711	1.0	25	70	-	2.0	0.41	1.0	0.2	400
1N6263	LL6263	1.0	25	60	-	2.0	0.41	1.0	0.2	400

1SS88 Series, Case Type: DO-35



1SS88		15	25	10	-	-	0.43	1.0	0.2	150
1SS106		30	25	10	-	-	4.50	1.0	70	-
1SS108		15	25	30	-	-	3.00	1.0	100	-

1SS165 Series, Case Type: DO-34



1SS165		15	25	10	-	-	0.6	10	0.2	150
1SS166		15	25	10	-	-	0.6	10	0.2	150
1SS198		30	25	10	-	-	1.0	4.5	70	-
1SS199		15	25	30	-	-	1.0	2.0	100	-
1SS286		35	25	25	-	-	0.6	10	0.01	150

BAT41 / LL41 Series, Case Type: DO-35 / MiniMELF



BAT41	LL41	100	25	100	350	0.75	0.45	1.0	0.1	400
BAT42	LL42	200	25	30	500	4.00	0.40	10	0.5/1.0	200
BAT43	LL43	200	25	30	500	4.00	0.33	2.0	0.5/1.0	200
BAT46	LL46	150	25	100	350	0.75	0.45	10	5.0	150/200
BAT48	LL48	350	25	40	1A	0.75	0.40	10	25	330

BAT81 Series, Case Type: DO-34



BAT81		30	25	40	150	0.5	0.41	1.0	0.2	200
BAT82		30	25	50	150	0.5	0.41	1.0	0.2	200
BAT83		30	25	60	150	0.5	0.41	1.0	0.2	200

BAT85/BAS85 Series, Case Type: DO-35 / MiniMELF



BAT85	BAS85	200	25	30	-	0.6	0.40	10	2.0	200
BAT86	BAS86	200	50	50	500	-	0.45	10	5.0	200

HSS100 Series, Case Type: DO-34



HSS100		35	25	60	-	-	0.9	20	0.10	150
HSS101		35	25	30	-	-	0.7	10	0.01	150
HSS102		35	25	70	-	-	1.1	20	0.01	150



Schottky Barrier Rectifiers

Type No.		Max. Average Forward Rectified Current		Max. Repetitive Peak Reverse Voltage	Max. Repetitive Peak Forward Current	Max. Forward Surge Current	Max. Forward Voltage Drop at Ta=25°C		Max. Reverse Current at Ta=25°C	Max. Power Dissipation
		I _{F(AV)}	@ Ta	V _{RRM}	I _{FRM}	I _{FSM}	V _F	@ I _F	I _R	P _D
Axial Lead	SMD	(mA)	(°C)	(V)	(mA)	(A)	(V)	(mA)	(μA)	(mW)

MA700 Series, Case Type: DO-34



MA700		150	25	15	-	-	0.4	10	0.10	-
MA700A		150	25	30	-	-	0.4	1.0	0.15	-

RB441Q-40 & RB721Q-40. Case Type: DO-34



RB441Q-40		10	25	40	-	1.0	0.34	10	100	-
RB721Q-40		30	25	40	-	200mA	0.37	1.0	0.5	-

SB0015-03A & SB0030-01A. Case Type: DO-34



SB0015-03A		15	25	30	-	-	1.0	3.0	100	-
SB0030-01A		30	25	10	-	-	1.0	4.5	70	-

SD101A/LL101A Series, Case Type: DO-35/MiniMELF



SD101A	LL101A	30	25	60	-	2.0	1.00	15	0.2	400
SD101B	LL101B	30	25	50	-	2.0	0.95	15	0.2	400
SD101C	LL101C	30	25	40	-	2.0	0.90	15	0.2	400

SD103A/LL103A Series, Case Type: DO-35/MiniMELF



SD103A	LL103A	200	25	40	-	15	0.55	200	5.0	400
SD103B	LL103B	200	25	50	-	15	0.55	200	5.0	400
SD103C	LL103C	200	25	60	-	15	0.55	200	5.0	400

1N5817WB Series, 1 A, Case Type: SOD-123



1N5817WB		1(A)	25	20	-	-	0.45	1.0	1.0	450
1N5818WB		1(A)	25	30	-	-	0.55	1.0	1.0	450
1N5819WB		1(A)	25	40	-	-	0.60	1.0	1.0	450



Schottky Barrier Rectifiers

Type No.	Max. Average Forward Rectified Current		Max. Repetitive Peak Reverse Voltage	Max. Repetitive Peak Forward Current	Max. Forward Surge Current	Max. Forward Voltage Drop at Ta=25°C		Max. Reverse Current at Ta=25°C	Max. Power Dissipation
	I _{F(AV)}	@ Ta	V _{RRM}	I _{FRM}	I _{FSM}	V _F	@ I _F	I _R	P _D
SMD	(mA)	(°C)	(V)	(mA)	(A)	(V)	(mA)	(μA)	(mW)

BAT42W Series, Case Type: SOD-123



BAT42W	200	25	30	-	4.0	1.00	200	0.5	-
BAT43W	200	25	30	-	4.0	1.00	200	0.5	-
BAT54W	200	25	30	-	1.0	0.65	100	2.0	200

Also available in SMD SOD-323 Case Types. Use suffix "S" to order (e.g. BAT42WS, BAT43WS)

SD101AWS Series, Case Type: SOD-323



SD101AWS	30	25	60	-	2.0	1.00	15	0.2	150
SD101BWS	30	25	50	-	2.0	0.95	15	0.2	150
SD101CWS	30	25	40	-	2.0	0.90	15	0.2	150

SD103AWS Series, Case Type: SOD-323



SD103AWS	200	25	40	-	2.0	0.60	200	5.0	150
SD103BWS	200	25	30	-	2.0	0.60	200	5.0	150
SD103CWS	200	25	20	-	2.0	0.60	200	5.0	150

1SS388, Case Type: SOD-523



1SS388	100	25	45	-	1.0	0.6	50	5.0	150
--------	-----	----	----	---	-----	-----	----	-----	-----

BAT54 Series, Case Type: SOT-23



BAT54	200	25	30	0.3	0.6	0.5	30	2.0	230
BAT54A	200	25	30	0.3	0.6	0.5	30	2.0	230
BAT54C	200	25	30	0.3	0.6	0.5	30	2.0	230
BAT54S	200	25	30	0.3	0.6	0.5	30	2.0	230

1SS294, Case Type: SOT-23



1SS294	300	25	45	-	-	0.6	10	5.0	150
--------	-----	----	----	---	---	-----	----	-----	-----

MA2Z748, Case Type: SOD-323



MA2Z748	300	25	20	-	3	0.4	300	30	-
---------	-----	----	----	---	---	-----	-----	----	---

MBR0520L Series, Case Type: SOD-123



MBR0520L	500	90	20	-	5.5	0.385	500	250	-
MBR0530	500	100	30	-	5.5	0.43	500	130	-
MBR0540	500	25	40	-	5.5	0.51	500	20	-

CRS08, 1.5 A, Case Type: SOD-123



CRS08	1.5(A)	86	30	-	30	0.36	1.5(A)	1(mA)	-
-------	--------	----	----	---	----	------	--------	-------	---

Zener Diodes 0.2 W

Type No.	Marking	Zener Voltage $V_Z @ I_{ZT}$			Max. Dynamic Resistance at I_{ZT}	Max. Reverse Leakage Current		Temp. coefficient of Zener Voltage at I_{ZT} $\alpha_{VZ} (10^{-4}/^{\circ}\text{C})$ (% / K)
		Min.	Max.	I_{ZT}	r_{zj}	$I_R @ V_R$		
		(V)	(V)	(mA)	(Ω)	(μA) (V)		

BZX384 Series, 0.2 W, Case Type : SOD-323



BZX384C2V4	W1	2.2	2.6	5.0	70 (≤ 100)	50	1.0	-9...-4
BZX384C2V7	W2	2.5	2.9	5.0	75 (≤ 100)	20	1.0	-9...-4
BZX384C3V0	W3	2.8	3.2	5.0	80 (≤ 95)	10	1.0	-9...-3
BZX384C3V3	W4	3.1	3.5	5.0	85 (≤ 95)	5.0	1.0	-8...-3
BZX384C3V6	W5	3.4	3.8	5.0	85 (≤ 90)	5.0	1.0	-8...-3
BZX384C3V9	W6	3.7	4.1	5.0	85 (≤ 90)	3.0	1.0	-7...-3
BZX384C4V3	W7	4.0	4.6	5.0	80 (≤ 90)	3.0	1.0	-6...-1
BZX384C4V7	W8	4.4	5.0	5.0	50 (≤ 80)	3.0	2.0	-5...+2
BZX384C5V1	W9	4.8	5.4	5.0	40 (≤ 60)	2.0	2.0	-3...+4
BZX384C5V6	WA	5.2	6.0	5.0	15 (≤ 40)	1.0	2.0	-2...+6
BZX384C6V2	WB	5.8	6.6	5.0	6 (≤ 10)	3.0	4.0	-1...+7
BZX384C6V8	WC	6.4	7.2	5.0	6 (≤ 15)	2.0	4.0	+2...+7
BZX384C7V5	WD	7.0	7.9	5.0	6 (≤ 15)	1.0	5.0	+4...+7
BZX384C8V2	WE	7.7	8.7	5.0	6 (≤ 15)	0.7	5.0	+5...+8
BZX384C9V1	WF	8.5	9.6	5.0	6 (≤ 15)	0.5	6.0	+5...+8
BZX384C10	WG	9.4	10.6	5.0	8 (≤ 20)	0.2	7.0	+5...+8
BZX384C11	WH	10.4	11.6	5.0	10 (≤ 20)	0.1	8.0	+5...+9
BZX384C12	WI	11.1	12.7	5.0	10 (≤ 25)	0.1	8.0	+6...+9
BZX384C13	WK	12.4	14.1	5.0	10 (≤ 30)	0.1	8.0	+7...+9
BZX384C15	WL	13.8	15.6	5.0	10 (≤ 30)	0.05	0.7V _{Znom}	+7...+9
BZX384C16	WM	15.3	17.1	5.0	10 (≤ 40)	0.05	0.7V _{Znom}	+8...+9.5
BZX384C18	WN	16.8	19.1	5.0	10 (≤ 45)	0.05	0.7V _{Znom}	+8...+9.5
BZX384C20	WO	18.8	21.2	5.0	15 (≤ 55)	0.05	0.7V _{Znom}	+8...+10
BZX384C22	WP	20.8	23.3	5.0	20 (≤ 55)	0.05	0.7V _{Znom}	+8...+10
BZX384C24	WR	22.8	25.6	5.0	25 (≤ 70)	0.05	0.7V _{Znom}	+8...+10
BZX384C27	WS	25.1	28.9	2.0	25 (≤ 80)	0.05	0.7V _{Znom}	+8...+10
BZX384C30	WT	28	32	2.0	30 (≤ 80)	0.05	0.7V _{Znom}	+8...+10
BZX384C33	WU	31	35	2.0	35 (≤ 80)	0.05	0.7V _{Znom}	+8...+10
BZX384C36	WW	34	38	2.0	35 (≤ 90)	0.05	0.7V _{Znom}	+8...+10
BZX384C39	WX	37	41	2.0	40 (≤ 130)	0.05	0.7V _{Znom}	+10...+12
BZX384C43	WY	40	46	2.0	45 (≤ 150)	0.05	0.7V _{Znom}	+10...+12
BZX384C47	WZ	44	50	2.0	50 (≤ 170)	0.05	0.7V _{Znom}	+10...+12
BZX384C51	X1	48	54	2.0	60 (≤ 180)	0.05	0.7V _{Znom}	+10...+12
BZX384C56	X2	52	60	2.0	70 (≤ 200)	0.05	0.7V _{Znom}	+9...+11
BZX384C62	X3	58	66	2.0	80 (≤ 215)	0.05	0.7V _{Znom}	+9...+12
BZX384C68	X4	64	72	2.0	90 (≤ 240)	0.05	0.7V _{Znom}	+10...+12
BZX384C75	X5	70	79	2.0	95 (≤ 255)	0.05	0.7V _{Znom}	+10...+12

Zener Diodes 0.2 W

Type No.	Zener Voltage $V_Z @ I_Z$			Operating Resistance Z_Z		Rising Operating Resistance, Z_{ZK}		Maximum Reverse Leakage Current	
	Min.	Max.	I_Z	Max.	@ I_Z	Max.	@ I_Z	I_R @	V_R
	(V)	(V)	(mA)	(Ω)	(mA)	(Ω)	(mA)	(μ A)	(V)

GDZ Series, 0.2 W, Case Type : SOD-323



GDZ2.0B	2.020	2.200	5.0	100	5.0	1000	0.5	120	0.5
GDZ2.2B	2.220	2.410	5.0	100	5.0	1000	0.5	120	0.7
GDZ2.4B	2.430	2.630	5.0	100	5.0	1000	0.5	120	1.0
GDZ2.7B	2.690	2.910	5.0	110	5.0	1000	0.5	100	1.0
GDZ3.0B	3.010	3.220	5.0	120	5.0	1000	0.5	50	1.0
GDZ3.3B	3.320	3.530	5.0	120	5.0	1000	0.5	20	1.0
GDZ3.6B	3.600	3.845	5.0	100	5.0	1000	1.0	10	1.0
GDZ3.9B	3.890	4.160	5.0	100	5.0	1000	1.0	5.0	1.0
GDZ4.3B	4.170	4.430	5.0	100	5.0	1000	1.0	5.0	1.0
GDZ4.7B	4.550	4.750	5.0	100	5.0	800	0.5	2.0	1.0
GDZ5.1B	4.980	5.200	5.0	80	5.0	500	0.5	2.0	1.0
GDZ5.6B	5.490	5.730	5.0	60	5.0	200	0.5	1.0	2.5
GDZ6.2B	6.060	6.330	5.0	60	5.0	100	0.5	1.0	3.0
GDZ6.8B	6.650	6.930	5.0	40	5.0	60	0.5	0.5	3.5
GDZ7.5B	7.280	7.600	5.0	30	5.0	60	0.5	0.5	4.0
GDZ8.2B	8.020	8.360	5.0	30	5.0	60	0.5	0.5	5.0
GDZ9.1B	8.850	9.230	5.0	30	5.0	60	0.5	0.1	6.0
GDZ10B	9.770	10.210	5.0	30	5.0	60	0.5	0.1	7.0
GDZ11B	10.760	11.220	5.0	30	5.0	60	0.5	0.1	8.0
GDZ12B	11.740	12.240	5.0	30	5.0	80	0.5	0.1	9.0
GDZ13B	12.910	13.490	5.0	37	5.0	80	0.5	0.1	10
GDZ15B	14.340	14.980	5.0	42	5.0	80	0.5	0.1	11
GDZ16B	15.850	16.510	5.0	50	5.0	80	0.5	0.1	12
GDZ18B	17.560	18.350	5.0	65	5.0	80	0.5	0.1	13
GDZ20B	19.520	20.390	5.0	85	5.0	100	0.5	0.1	15
GDZ22B	21.540	22.470	5.0	100	5.0	100	0.5	0.1	17
GDZ24B	23.720	24.780	5.0	120	5.0	120	0.5	0.1	19
GDZ27B	26.190	27.530	5.0	150	5.0	150	0.5	0.1	21
GDZ30B	29.190	30.690	5.0	200	5.0	200	0.5	0.1	23
GDZ33B	32.150	33.790	5.0	250	5.0	250	0.5	0.1	25
GDZ36B	35.070	36.870	5.0	300	5.0	300	0.5	0.1	27

Notes:

- (1) The Zener voltage V_Z is measured 40 ms after power is supplied
- (2) The operating resistances (Z_Z , Z_{ZK}) are measured by superimposing a 1KHz alternating current on the regulated current (I_Z)



Zener Diodes 0.2 W

Type No.	Marking	Zener Voltage (Note 1)			Test Current	Zener Impedance		Test Current	Leakage Current	
		$V_Z @ I_{ZT}$ (V)			I_{ZT}	$Z_{ZT} @ I_{ZT}$	$Z_{ZK} @ I_{ZK}$	I_{ZK}	$I_R @ V_R$	V_R
		Min.	Nom.	Max.	(mA)	(Ω)	(Ω)	(mA)	(μ A)	(V)

MM5Z2V4 Series, 0.2 W, Case Type : SOD-523



MM5Z2V4	Z7	2.2	2.4	2.6	5	100	1000	1.0	50	1.0
MM5Z2V7	A8	2.5	2.7	2.9	5	100	1000	1.0	20	1.0
MM5Z3V0	B8	2.8	3.0	3.2	5	100	1000	1.0	10	1.0
MM5Z3V3	C8	3.1	3.3	3.5	5	95	1000	1.0	5	1.0
MM5Z3V6	D8	3.4	3.6	3.8	5	90	1000	1.0	5	1.0
MM5Z3V9	E8	3.7	3.9	4.1	5	90	1000	1.0	3	1.0
MM5Z4V3	F8	4.0	4.3	4.6	5	90	1000	1.0	3	1.0
MM5Z4V7	G8	4.4	4.7	5.0	5	80	800	1.0	3	2.0
MM5Z5V1	H8	4.8	5.1	5.4	5	60	500	1.0	2	2.0
MM5Z5V6	I8	5.2	5.6	6.0	5	40	200	1.0	1	2.0
MM5Z6V2	J8	5.8	6.2	6.6	5	10	100	1.0	3	4.0
MM5Z6V8	K8	6.4	6.8	7.2	5	15	160	1.0	2	4.0
MM5Z7V5	L8	7.0	7.5	7.9	5	15	160	1.0	1	5.0
MM5Z8V2	M8	7.7	8.2	8.7	5	15	160	1.0	0.7	5.0
MM5Z9V1	N8	8.5	9.1	9.6	5	15	160	1.0	0.2	7.0
MM5Z10V	O8	9.4	10	10.6	5	20	160	1.0	0.1	8.0
MM5Z11V	P8	10.4	11	11.6	5	20	160	1.0	0.1	8.0
MM5Z12V	Q8	11.4	12	12.7	5	25	80	1.0	0.1	8.0
MM5Z13V	R8	12.4	13.25	14.1	5	30	80	1.0	0.1	8.0
MM5Z15V	S8	14.3	15	15.8	5	30	80	1.0	0.05	10.5
MM5Z16V	T8	15.3	16.2	17.1	5	40	80	1.0	0.05	11.2
MM5Z18V	U8	16.8	18	19.1	5	45	80	1.0	0.05	12.6
MM5Z20V	V8	18.8	20	21.2	5	55	100	1.0	0.05	14.0
MM5Z22V	W8	20.8	22	23.3	5	55	100	1.0	0.05	15.4
MM5Z24V	X8	22.8	24.2	25.6	5	70	120	1.0	0.05	16.8
MM5Z27V	Y8	25.1	27	28.9	2	80	300	1.0	0.05	18.9
MM5Z30V	Z8	28	30	32	2	80	300	1.0	0.05	21.0
MM5Z33V	A9	31	33	35	2	80	300	1.0	0.05	23.2
MM5Z36V	B9	34	36	38	2	90	500	1.0	0.05	25.2
MM5Z39V	C9	37	39	41	2	130	500	1.0	0.05	27.3
MM5Z43V	D9	40	43	46	2	150	500	1.0	0.05	30.1
MM5Z47V	E9	44	47	50	2	170	500	1.0	0.05	32.9
MM5Z51V	F9	48	51	54	2	180	500	1.0	0.05	35.7
MM5Z56V	G9	52	56	60	2	200	500	1.0	0.05	39.2
MM5Z62V	H9	58	62	66	2	215	500	1.0	0.05	43.4
MM5Z68V	I9	64	68	72	2	240	500	1.0	0.05	47.6
MM5Z75V	J9	70	75	79	2	255	500	1.0	0.05	52.5

Note :

(1) Zener voltage is measured with a pulse test current I_Z at an ambient temperature of 25 °C.



Zener Diodes 0.2 W

Type No.	Marking	Zener Voltage ⁽¹⁾			Test Current	Zener Impedance	Test Current	Leakage Current	
		V _Z @ I _{ZT} (V)			I _{ZT}	Z _{ZT} @ I _{ZT}	I _{ZT}	I _R @	V _R
		Min.	Nom.	Max.	(mA)	(Ω)	(mA)	(μA)	(V)

MM5Z2B4 Series, 0.2 W, Case Type : SOD-523



MM5Z2B4	XY	2.352	2.4	2.448	5.0	100	5.0	120	1.0
MM5Z2B7	XZ	2.646	2.7	2.754	5.0	110	5.0	120	1.0
MM5Z3B0	FR	2.940	3.0	3.060	5.0	120	5.0	50	1.0
MM5Z3B3	FX	3.234	3.3	3.366	5.0	130	5.0	20	1.0
MM5Z3B6	FY	3.528	3.6	3.672	5.0	130	5.0	10	1.0
MM5Z3B9	FZ	3.822	3.9	3.978	5.0	130	5.0	5.0	1.0
MM5Z4B3	HA	4.214	4.3	4.386	5.0	130	5.0	5.0	1.0
MM5Z4B7	HB	4.606	4.7	4.794	5.0	130	5.0	2.0	1.0
MM5Z5B1	HC	4.998	5.1	5.202	5.0	130	5.0	2.0	1.5
MM5Z5B6	HD	5.488	5.6	5.712	5.0	80	5.0	1.0	2.5
MM5Z6B2	HE	6.076	6.2	6.324	5.0	50	5.0	1.0	3.0
MM5Z6B8	HF	6.664	6.8	6.936	5.0	30	5.0	0.5	3.5
MM5Z7B5	HH	7.350	7.5	7.650	5.0	30	5.0	0.5	4.0
MM5Z8B2	HJ	8.036	8.2	8.364	5.0	30	5.0	0.5	5.0
MM5Z9B1	HK	8.918	9.1	9.282	5.0	30	5.0	0.5	6.0
MM5ZB10	HM	9.80	10	10.20	5.0	30	5.0	0.1	7.0
MM5ZB11	HN	10.78	11	11.22	5.0	30	5.0	0.1	8.0
MM5ZB12	HP	11.76	12	12.24	5.0	35	5.0	0.1	9.0
MM5ZB13	HR	12.74	13	13.26	5.0	35	5.0	0.1	10
MM5ZB15	HX	14.70	15	15.30	5.0	40	5.0	0.1	11
MM5ZB16	HY	15.68	16	16.32	5.0	40	5.0	0.1	12
MM5ZB18	HZ	17.64	18	18.36	5.0	45	5.0	0.1	13
MM5ZB20	JA	19.60	20	20.40	5.0	50	5.0	0.1	15
MM5ZB22	JB	21.56	22	22.44	5.0	55	5.0	0.1	17
MM5ZB24	JC	23.52	24	24.48	5.0	60	5.0	0.1	19
MM5ZB27	JD	26.46	27	27.54	5.0	70	2.0	0.1	21
MM5ZB30	JE	29.40	30	30.60	5.0	80	2.0	0.1	23
MM5ZB33	JF	32.34	33	33.66	5.0	80	2.0	0.1	25
MM5ZB36	JH	35.28	36	36.72	5.0	90	2.0	0.1	27
MM5ZB39	JJ	38.22	39	39.78	2.5	100	2.0	2.0	30
MM5ZB43	JK	42.14	43	43.86	2.5	130	2.0	2.0	33
MM5ZB47	JM	46.06	47	47.94	2.5	150	2.0	2.0	36
MM5ZB51	YA	49.98	51	52.02	2.5	180	2.0	1.0	39
MM5ZB56	YB	54.88	56	57.12	2.5	180	2.0	1.0	43
MM5ZB62	YC	60.76	62	63.24	2.5	200	2.0	0.2	47
MM5ZB68	YD	66.64	68	69.36	2.5	250	2.0	0.2	52
MM5ZB75	YE	73.50	75	76.50	2.5	300	2.0	0.2	57

Note :

(1) Tested with pulses $t_p = 20$ ms.

Zener Diodes 0.25 W

Type No.	Suffix ⁽¹⁾	Zener Voltage		Test Current	Maximum Dynamic Resistance		Maximum Reverse Current		Typical Temperature Coefficient *	
		V _Z (V)			I _{ZT} (mA)	r _d (Ω)	@ I _Z (mA)	I _R (μA)	@ V _R (V)	γ _Z (mV/ °C)
		min.	max.							

HZK-LL Series, 0.25 W, Case Type : MiniMELF



Type No.	Suffix	V _Z (V) min.	V _Z (V) max.	I _{ZT} (mA)	r _d (Ω)	@ I _Z (mA)	I _R (μA)	@ V _R (V)	γ _Z (mV/ °C)	I _Z (mA)
HZK2LL	A	1.6	2.0	0.5	350	0.5	0.5	0.5	1.2	50
	B	1.9	2.3							
	C	2.2	2.6							
HZK3LL	A	2.5	2.9	0.5	360	0.5	0.5	1.0	1.2	50
	B	2.8	3.2							
	C	3.1	3.5							
HZK4LL	A	3.4	3.8	0.5	370	0.5	0.5	2.0	1.5	50
	B	3.7	4.1							
	C	4.0	4.4							
HZK5LL	A	4.3	4.7	0.5	380	0.5	0.5	3.0	1.5	50
	B	4.6	5.0							
	C	4.9	5.3							

* $\Delta V_{Z1} = V_Z (I_Z = 0.5 \text{ mA}) - V_{Z1} (I_Z = 0.05 \text{ mA})$

$\Delta V_{Z2} = V_{Z1} (I_Z = 0.05 \text{ mA}) - V_{Z2} (I_Z = 0.001 \text{ mA})$

Note:

(1) When placing an order for an HZK-LL type, enter "A", "B" or "C" suffix e.g. HZK2ALL, HZK2BLL ... HZK5CLL



Zener Diodes 0.25 W

Type No.	Grade	Zener Voltage $V_Z @ I_{ZT}$						Test Current	Maximum Dynamic Resistance		Maximum Reverse Current	
		Suffix -1		Suffix -2		Suffix -3			I_{ZT} (mA)	rd @ I_Z (W)	$I_R @ V_R$ (μ A)	V_R (V)
		min. (V)	max. (V)	min. (V)	max. (V)	min. (V)	max. (V)					

HZS Series, 0.25 W, Case Type : DO-34



HZS2	A	1.6	1.8	1.7	1.9	1.8	2.0	5	100	5	25	0.5
	B	1.9	2.1	2.0	2.2	2.1	2.3	5	100	5	2	0.5
	C	2.2	2.4	2.3	2.5	2.4	2.6	5	100	5	1	0.5
HZS3	A	2.5	2.7	2.6	2.8	2.7	2.9	5	100	5	1	0.5
	B	2.8	3.0	2.9	3.1	3.0	3.2	5	100	5	1	0.5
	C	3.1	3.3	3.2	3.4	3.3	3.5	5	100	5	1	0.5
HZS4	A	3.4	3.6	3.5	3.7	3.6	3.8	5	100	5	5	1.00
	B	3.7	3.9	3.8	4.0	3.9	4.1	5	100	5	5	1.00
	C	4.0	4.2	4.1	4.3	4.2	4.4	5	100	5	5	1.00
HZS5	A	4.3	4.5	4.4	4.6	4.5	4.7	5	100	5	5	1.5
	B	4.6	4.8	4.7	4.9	4.8	5.0	5	100	5	5	1.5
	C	4.9	5.1	5.0	5.2	5.1	5.3	5	100	5	5	1.5
HZS6	A	5.2	5.5	5.3	5.6	5.4	5.7	5	35	5	5	2.0
	B	5.5	5.8	5.6	5.9	5.7	6.0	5	35	5	5	2.0
	C	5.8	6.1	6.0	6.3	6.1	6.4	5	35	5	5	2.0
HZS7	A	6.3	6.6	6.4	6.7	6.6	6.9	5	15	5	1	3.5
	B	6.7	7.0	6.9	7.2	7.0	7.3	5	15	5	1	3.5
	C	7.2	7.6	7.3	7.7	7.5	7.9	5	15	5	1	3.5
HZS9	A	7.7	8.1	7.9	8.3	8.1	8.5	5	20	5	1	5.0
	B	8.3	8.7	8.5	8.9	8.7	9.1	5	20	5	1	5.0
	C	8.9	9.3	9.1	9.5	9.3	9.7	5	20	5	1	5.0
HZS11	A	9.5	9.9	9.7	10.1	9.9	10.3	5	25	5	1	7.5
	B	10.2	10.6	10.4	10.8	10.7	11.1	5	25	5	1	7.5
	C	10.9	11.3	11.1	11.6	11.4	11.9	5	25	5	1	7.5
HZS12	A	11.6	12.1	11.9	12.4	12.2	12.7	5	35	5	1	9.5
	B	12.4	12.9	12.6	13.1	12.9	13.4	5	35	5	1	9.5
	C	13.2	13.7	13.5	14.0	13.8	14.3	5	35	5	1	9.5
HZS15		14.1	14.7	14.5	15.1	14.9	15.5	5	40	5	1	11
HZS16		15.3	15.9	15.7	16.5	16.3	17.1	5	45	5	1	12
HZS18		16.9	17.7	17.5	18.3	18.1	19.0	5	55	5	1	13
HZS20		18.8	19.7	19.5	20.4	20.2	21.1	2	60	2	1	15
HZS22		20.9	21.9	21.6	22.6	22.3	23.3	2	65	2	1	17
HZS24		22.9	24.0	23.6	24.7	24.3	25.5	2	70	2	1	19
HZS27		25.2	26.6	26.2	27.6	27.2	28.6	2	80	2	1	21
HZS30		28.2	29.6	29.2	30.6	30.2	31.6	2	100	2	1	23
HZS33		31.2	32.6	32.2	33.6	33.2	34.6	2	120	2	1	25
HZS36		34.2	35.7	35.3	36.8	36.4	38.0	2	140	2	1	27

Note :

The lower voltage types (HZS2 - HZS12) are available in 3 grades, "A" to "C", each with suffix "-1", "-2" or "-3"

For example the type with $V_Z = 8.5 - 8.9V$ is HZS9B-2

The higher voltage types are only available with suffix "-1", "-2" or "-3" (no grade) e.g. HZS30-3



Zener Diodes 0.25 W

Type No.	Suffix ⁽¹⁾	Zener Voltage		Test Current	Maximum Dynamic Resistance		Maximum Reverse Current		Typical Temperature Coefficient *	
		V _Z (V)			I _{ZT} (mA)	r _d (Ω)	@ I _Z (mA)	I _R (μA)	@ V _R (V)	γ _Z (mV/ °C)
		min.	max.							

HZS-LL Series, 0.25 W, Case Type : DO-34



HZS2LL	A	1.6	2.0	0.5	100	0.5	350	0.5	1.2	50
	B	1.9	2.3							
	C	2.2	2.6							
HZS3LL	A	2.5	2.9	0.5	100	1.0	360	0.5	1.2	50
	B	2.8	3.2							
	C	3.1	3.5							
HZS4LL	A	3.4	3.8	0.5	100	2.0	370	0.5	1.5	50
	B	3.7	4.1							
	C	4.0	4.4							
HZS5LL	A	4.3	4.7	0.5	100	3.0	380	0.5	1.5	50
	B	4.6	5.0							
	C	4.9	5.3							

* $\Delta V_{Z1} = V_Z (I_Z = 0.5 \text{ mA}) - V_{Z1} (I_Z = 0.05 \text{ mA})$

$\Delta V_{Z2} = V_{Z1} (I_Z = 0.5 \text{ mA}) - V_{Z2} (I_Z = 0.05 \text{ mA})$

Note:

(1) When placing an order for HZS-LL type, enter suffix "A", "B" or "C" e.g. HZS2ALL, HZS2BLL HZS5CLL



Zener Diodes 0.3 W

Type No.	Marking	Zener Voltage ⁽¹⁾			Test Current	Zener Impedance ⁽²⁾	Test Current	Leakage Current		Temp. coefficient of Zener Voltage	
		V _Z @ I _{ZT} (V)						I _R @ V _R	TKvz (%/K)		
		Min.	Nom.	Max.	I _{ZT} (mA)	Z _Z @ I _Z (Ω)	I _Z (mA)	I _R (μA)	V _R (V)	Min.	Max.

MM3Z2V0 Series, 0.3 W, Case Type : SOD-323



MM3Z2V0	B0	1.80	2.0	2.15	5.0	100	5.0	120	0.5	-0.09	-0.06
MM3Z2V2	C0	2.08	2.2	2.33	5.0	100	5.0	120	0.7	-0.09	-0.06
MM3Z2V4	1C	2.28	2.4	2.56	5.0	100	5.0	120	1.0	-0.09	-0.06
MM3Z2V7	1D	2.5	2.7	2.9	5.0	110	5.0	120	1.0	-0.09	-0.06
MM3Z3V0	1E	2.8	3.0	3.2	5.0	120	5.0	50	1.0	-0.08	-0.05
MM3Z3V3	1F	3.1	3.3	3.5	5.0	130	5.0	20	1.0	-0.08	-0.05
MM3Z3V6	1H	3.4	3.6	3.8	5.0	130	5.0	10	1.0	-0.08	-0.05
MM3Z3V9	1J	3.7	3.9	4.1	5.0	130	5.0	5.0	1.0	-0.08	-0.05
MM3Z4V3	1K	4.0	4.3	4.6	5.0	130	5.0	5.0	1.0	-0.06	-0.03
MM3Z4V7	1M	4.4	4.7	5.0	5.0	130	5.0	2.0	1.0	-0.05	+0.02
MM3Z5V1	1N	4.8	5.1	5.4	5.0	130	5.0	2.0	1.5	-0.02	+0.02
MM3Z5V6	1P	5.2	5.6	6.0	5.0	80	5.0	1.0	2.5	-0.05	+0.05
MM3Z6V2	1R	5.8	6.2	6.6	5.0	50	5.0	1.0	3.0	0.03	0.06
MM3Z6V8	1X	6.4	6.8	7.2	5.0	30	5.0	0.5	3.5	0.03	0.07
MM3Z7V5	1Y	7.0	7.5	7.9	5.0	30	5.0	0.5	4.0	0.03	0.07
MM3Z8V2	1Z	7.7	8.2	8.7	5.0	30	5.0	0.5	5.0	0.03	0.08
MM3Z9V1	2A	8.5	9.1	9.6	5.0	30	5.0	0.5	6.0	0.03	0.09
MM3Z10	2B	9.4	10	10.6	5.0	30	5.0	0.1	7.0	0.03	0.10
MM3Z11	2C	10.4	11	11.6	5.0	30	5.0	0.1	8.0	0.03	0.11
MM3Z12	2D	11.4	12	12.7	5.0	35	5.0	0.1	9.0	0.03	0.11
MM3Z13	2E	12.4	13	14.1	5.0	35	5.0	0.1	10	0.03	0.11
MM3Z15	2F	13.8	15	15.8	5.0	40	5.0	0.1	11	0.03	0.11
MM3Z16	2H	15.3	16	17.1	5.0	40	5.0	0.1	12	0.03	0.11
MM3Z18	2J	16.8	18	19.1	5.0	45	5.0	0.1	13	0.03	0.11
MM3Z20	2K	18.8	20	21.2	5.0	50	5.0	0.1	15	0.03	0.11
MM3Z22	2M	20.8	22	23.3	5.0	55	5.0	0.1	17	0.04	0.12
MM3Z24	2N	22.8	24	25.6	5.0	60	2.0	0.1	19	0.04	0.12
MM3Z27	2P	25.1	27	28.9	5.0	70	2.0	0.1	21	0.04	0.12
MM3Z30	2R	28	30	32	5.0	80	2.0	0.1	23	0.04	0.12
MM3Z33	2X	31	33	35	5.0	80	2.0	0.1	25	0.04	0.12
MM3Z36	2Y	34	36	38	5.0	90	2.0	0.1	27	0.04	0.12
MM3Z39	2Z	37	39	41	2.5	100	2.0	2.0	30	0.04	0.12
MM3Z43	3A	40	43	46	2.5	130	2.0	2.0	33	0.04	0.12
MM3Z47	3B	44	47	50	2.5	150	2.0	2.0	36	0.04	0.12
MM3Z51	3C	48	51	54	2.5	180	2.0	1.0	39	0.04	0.12
MM3Z56	3D	52	56	60	2.5	180	2.0	1.0	43	0.04	0.12
MM3Z62	3E	58	62	66	2.5	200	2.0	0.2	47	0.04	0.12
MM3Z68	3F	64	68	72	2.5	250	2.0	0.2	52	0.04	0.12
MM3Z75	3H	70	75	79	2.5	300	2.0	0.2	57	0.04	0.12
MM3Z82	3J	77	82	87	2.5	300	2.0	0.2	63	0.05	0.12
MM3Z91	3K	85	91	96	1.0	700	1.0	0.2	69	0.05	0.12
MM3Z100	3M	94	100	106	1.0	700	1.0	0.2	76	0.05	0.12
MM3Z110	3N	104	110	116	1.0	800	1.0	0.2	84	0.05	0.12
MM3Z120	3P	114	120	127	1.0	900	1.0	0.2	91	0.05	0.12

Note :

(1) Vz is tested with pulses (20 ms).

Zener Diodes 0.3 W

Type No.	Marking	Zener Voltage ⁽¹⁾			Test Current	Dynamic Impedance ⁽²⁾	Test Current	Reverse Leakage Current		Temp. coefficient of Zener Voltage	
		V _Z @ I _{ZT} (V)						I _Z	I _R @ V _R	TK _{VZ} (%/K)	
		Min.	Nom.	Max.	(mA)	(Ω)	(mA)	(μA)	(V)	Min.	Max.

MM3Z2V0B Series, 0.3 W, Case Type : SOD-323



MM3Z2V0B	B0	1.80	2.0	2.15	5	100	5	120	0.5	-0.09	-0.06
MM3Z2V2B	MF	2.08	2.2	2.33	5	100	5	120	0.7	-0.09	-0.06
MM3Z2V4B	7C	2.30	2.4	2.65	5	100	5	120	1.0	-0.09	-0.06
MM3Z2V7B	7D	2.65	2.7	2.95	5	110	5	120	1.0	-0.09	-0.06
MM3Z3V0B	7E	2.95	3.0	3.25	5	120	5	50	1.0	-0.08	-0.05
MM3Z3V3B	7F	3.25	3.3	3.55	5	120	5	20	1.0	-0.08	-0.05
MM3Z3V6B	7H	3.60	3.6	3.845	5	100	5	10	1.0	-0.08	-0.05
MM3Z3V9B	7J	3.89	3.9	4.16	5	100	5	5	1.0	-0.08	-0.05
MM3Z4V3B	7K	4.17	4.3	4.43	5	100	5	5	1.0	-0.06	-0.03
MM3Z4V7B	7M	4.55	4.7	4.75	5	100	5	2	1.0	-0.05	+0.02
MM3Z5V1B	7N	4.98	5.1	5.20	5	80	5	2	1.5	-0.02	+0.02
MM3Z5V6B	7P	5.49	5.6	5.73	5	60	5	1	2.5	-0.05	+0.05
MM3Z6V2B	7R	6.06	6.2	6.33	5	60	5	1	3.0	0.03	0.06
MM3Z6V8B	7X	6.65	6.8	6.93	5	40	5	0.5	3.5	0.03	0.07
MM3Z7V5B	7Y	7.28	7.5	7.60	5	30	5	0.5	4.0	0.03	0.07
MM3Z8V2B	7Z	8.02	8.2	8.36	5	30	5	0.5	5.0	0.03	0.08
MM3Z9V1B	8A	8.85	9.1	9.23	5	30	5	0.5	6.0	0.03	0.09
MM3Z10B	8B	9.77	10	10.21	5	30	5	0.1	7.0	0.03	0.10
MM3Z11B	8C	10.76	11	11.22	5	30	5	0.1	8.0	0.03	0.11
MM3Z12B	8D	11.74	12	12.24	5	30	5	0.1	9.0	0.03	0.11
MM3Z13B	8E	12.91	13	13.49	5	37	5	0.1	10	0.03	0.11
MM3Z15B	8F	14.34	15	14.98	5	42	5	0.1	11	0.03	0.11
MM3Z16B	8H	15.85	16	16.51	5	50	5	0.1	12	0.03	0.11
MM3Z18B	8J	17.56	18	18.35	5	65	5	0.1	13	0.03	0.11
MM3Z20B	8K	19.52	20	20.39	5	85	5	0.1	15	0.03	0.11
MM3Z22B	8M	21.54	22	22.47	5	100	5	0.1	17	0.04	0.12
MM3Z24B	8N	23.72	24	24.78	5	120	5	0.1	19	0.04	0.12
MM3Z27B	8P	26.19	27	27.53	5	150	2	0.1	21	0.04	0.12
MM3Z30B	8R	29.19	30	30.69	5	200	2	0.1	23	0.04	0.12
MM3Z33B	8X	32.15	33	33.79	5	250	2	0.1	25	0.04	0.12
MM3Z36B	8Y	35.07	36	36.87	5	300	2	0.1	27	0.04	0.12
MM3Z39B	8Z	37.00	39	41.00	5	100	2	2.0	30	0.04	0.12

Notes :

(1) V_Z is tested with pulses (20 ms).

(2) Z_Z is measured at I_Z by given a very small A.C. current signal.



Zener Diodes 0.35 W

Type No.	Marking	Zener Voltage ⁽¹⁾			Test Current	Maximum Zener Impedance		Test Current	Maximum Reverse Leakage Current	
		V _Z @ I _{ZT} (V)				Z _{ZT} @ I _{ZT}	Z _{ZK} @ I _{ZK}		I _R @ V _R	
		Min.	Nom.	Max.	(mA)	(Ω)	(Ω)	(mA)	(μA)	(V)

MMBZ5221B Series, 0.35 W, Case Type : SOT-23



MMBZ5221B	Y0	2.28	2.4	2.52	20	30	1200	0.25	100	1.0
MMBZ5223B	Z0	2.57	2.7	2.84	20	30	1300	0.25	75	1.0
MMBZ5225B	AA	2.85	3.0	3.15	20	29	1600	0.25	50	1.0
MMBZ5226B	AB	3.14	3.3	3.47	20	28	1600	0.25	25	1.0
MMBZ5227B	AC	3.42	3.6	3.78	20	24	1700	0.25	15	1.0
MMBZ5228B	AD	3.71	3.9	4.10	20	23	1900	0.25	10	1.0
MMBZ5229B	AE	4.09	4.3	4.52	20	22	2000	0.25	5	1.0
MMBZ5230B	AF	4.47	4.7	4.94	20	19	1900	0.25	5	2.0
MMBZ5231B	AH	4.85	5.1	5.36	20	17	1600	0.25	5	2.0
MMBZ5232B	AJ	5.32	5.6	5.88	20	11	1600	0.25	5	3.0
MMBZ5233B	AK	5.70	6.0	6.30	20	7	1600	0.25	5	3.5
MMBZ5234B	AM	5.89	6.2	6.51	20	7	1000	0.25	5	4.0
MMBZ5235B	AN	6.46	6.8	7.14	20	5	750	0.25	3	5.0
MMBZ5236B	AP	7.13	7.5	7.88	20	6	500	0.25	3	6.0
MMBZ5237B	AR	7.79	8.2	8.61	20	8	500	0.25	3	6.5
MMBZ5238B	AX	8.27	8.7	9.14	20	8	600	0.25	3	6.5
MMBZ5239B	AY	8.65	9.1	9.56	20	10	600	0.25	3	7.0
MMBZ5240B	AZ	9.50	10	10.50	20	17	600	0.25	3	8.0
MMBZ5241B	BA	10.45	11	11.50	20	22	600	0.25	2	8.4
MMBZ5242B	BB	11.40	12	12.60	20	30	600	0.25	1	9.1
MMBZ5243B	BC	12.35	13	13.65	9.5	13	600	0.25	0.5	9.9
MMBZ5245B	BE	14.25	15	15.75	8.5	16	600	0.25	0.1	11
MMBZ5246B	BF	15.20	16	16.80	7.8	17	600	0.25	0.1	12
MMBZ5247B	BH	16.15	17	17.85	7.4	19	600	0.25	0.1	13
MMBZ5248B	BJ	17.10	18	18.90	7.0	21	600	0.25	0.1	14
MMBZ5249B	BK	18.05	19	19.95	6.6	23	600	0.25	0.1	14
MMBZ5250B	BM	19.00	20	21.00	6.2	25	600	0.25	0.1	15
MMBZ5251B	BN	20.90	22	23.10	5.6	29	600	0.25	0.1	17
MMBZ5252B	BP	22.80	24	25.20	5.2	33	600	0.25	0.1	18
MMBZ5253B	BR	23.75	25	26.25	5.0	35	600	0.25	0.1	19
MMBZ5254B	BX	25.65	27	28.35	4.6	41	600	0.25	0.1	21
MMBZ5255B	BY	26.60	28	29.40	4.5	44	600	0.25	0.1	21
MMBZ5256B	BZ	28.50	30	31.50	4.2	49	600	0.25	0.1	23
MMBZ5257B	CA	31.35	33	34.65	3.8	58	700	0.25	0.1	25
MMBZ5258B	CB	34.20	36	37.80	3.4	70	700	0.25	0.1	27
MMBZ5259B	CC	37.05	39	40.95	3.2	80	800	0.25	0.1	30
MMBZ5260B	CD	40.85	43	45.15	3.0	93	900	0.25	0.1	33
MMBZ5261B	CE	44.65	47	49.35	2.7	105	1000	0.25	0.1	36

Note :

(1) Tested with pulses tp = 20 ms



Zener Diodes 0.4 W

Type No.	Grade	Zener Voltage $V_Z @ I_{ZT}$						Test Current	Maximum Dynamic Resistance		Maximum Reverse Current	
		Suffix -1		Suffix -2		Suffix -3			I_{ZT}	rd @ I_Z	$I_R @ V_R$	
		min. (V)	max. (V)	min. (V)	max. (V)	min. (V)	max. (V)	(mA)				

HZ6L Series, 0.4 W, Case Type : DO-35



HZ6L	A	5.2	5.5	5.3	5.6	5.4	5.7	0.5	150	0.5	1	2.0
	B	5.5	5.8	5.6	5.9	5.7	6.0	0.5	80	0.5	1	2.0
	C	5.8	6.1	6.0	6.3	6.1	6.4	0.5	60	0.5	1	2.0
HZ7L	A	6.3	6.6	6.4	6.7	6.6	6.9	0.5	60	0.5	1	3.5
	B	6.7	7.0	6.9	7.2	7.0	7.3	0.5	60	0.5	1	3.5
	C	7.2	7.6	7.3	7.7	7.5	7.9	0.5	60	0.5	1	3.5
HZ9L	A	7.7	8.1	7.9	8.3	8.1	8.5	0.5	60	0.5	1	6.0
	B	8.3	8.7	8.5	8.9	8.7	9.1	0.5	60	0.5	1	6.0
	C	8.9	9.3	9.1	9.5	9.3	9.7	0.5	60	0.5	1	6.0
HZ11L	A	9.5	9.9	9.7	10.1	9.9	10.3	0.5	80	0.5	1	8.0
	B	10.2	10.6	10.4	10.8	10.7	11.1	0.5	80	0.5	1	8.0
	C	10.9	11.3	11.1	11.6	11.4	11.9	0.5	80	0.5	1	8.0
HZ12L	A	11.6	12.1	11.9	12.4	12.2	12.7	0.5	80	0.5	1	10.5
	B	12.4	12.9	12.6	13.1	12.9	13.4	0.5	80	0.5	1	10.5
	C	13.2	13.7	13.5	14.0	13.8	14.3	0.5	80	0.5	1	10.5
HZ15L		14.1	14.7	14.5	15.1	14.9	15.5	0.5	80	0.5	1	13.0
HZ16L		15.3	15.9	15.7	16.5	16.3	17.1	0.5	80	0.5	1	14.0
HZ18L		16.9	17.7	17.5	18.3	18.1	19.0	0.5	80	0.5	1	15.0
HZ20L		18.8	19.7	19.5	20.4	20.2	21.1	0.5	100	0.5	1	18.0
HZ22L		20.9	21.9	21.6	22.6	22.3	23.3	0.5	100	0.5	1	20.0
HZ24L		22.9	24.0	23.6	24.7	24.3	25.5	0.5	120	0.5	1	22.0
HZ27L		25.2	26.6	26.2	27.6	27.2	28.6	0.5	150	0.5	1	24.0
HZ30L		28.2	29.6	29.2	30.6	30.2	31.6	0.5	200	0.5	1	27.0
HZ33L		31.2	32.6	32.2	33.6	33.2	34.6	0.5	250	0.5	1	30.0
HZ36L		34.2	35.7	35.3	36.8	36.4	38.0	0.5	300	0.5	1	33.0

Note :

The lower voltage types (HZ6L - HZ12L) are available in 3 grades, "A" to "C", each with suffix "-1", "-2" or "-3"

For example the type with $V_Z = 8.5 - 8.9V$ is HZ9B2L

The higher voltage types are only available with suffix "-1", "-2" or "-3" (no grade) e.g. HZ30-3L



Zener Diodes 0.4 W

Type No.	Suffix ⁽¹⁾	Zener Voltage		Test Current	Maximum Dynamic Resistance			Maximum Reverse Current		Typical Temperature Coefficient *		
		V _Z (V)		I _{ZT}	rd	@	I _Z	I _R	@	V _R	γ _Z (mV/ °C)	I _Z
		min.	max.	(mA)	(Ω)		(mA)	(μA)	(V)	(mA)		

HZK-L Series, 0.4 W, Case Type : MiniMELF



HZK6L	A1	5.2	5.5	0.5	150	0.5	1	2.0	1.0	0.5
	A2	5.3	5.6							
	A3	5.4	5.7							
	B1	5.5	5.8		80					
	B2	5.6	5.9							
	B3	5.7	6.0							
	C1	5.8	6.1		60					
	C2	6.0	6.3							
	C3	6.1	6.4							
HZK7L	A1	6.3	6.6	0.5	60	0.5	1	3.5	2.0	0.5
	A2	6.4	6.7							
	A3	6.6	6.9							
	B1	6.7	7.0							
	B2	6.9	7.2							
	B3	7.0	7.3							
	C1	7.2	7.6							
	C2	7.3	7.7							
	C3	7.5	7.9							
HZK9L	A1	7.7	8.1	0.5	60	0.5	1	6.0	3.0	0.5
	A2	7.9	8.3							
	A3	8.1	8.5							
	B1	8.3	8.7							
	B2	8.5	8.9							
	B3	8.7	9.1							
	C1	8.9	9.3							
	C2	9.1	9.5							
	C3	9.3	9.7							
HZK11L	A1	9.5	9.9	0.5	80	0.5	1	8.0	5.0	0.5
	A2	9.7	10.1							
	A3	9.9	10.3							
	B1	10.2	10.6							
	B2	10.4	10.8							
	B3	10.7	11.1							
	C1	10.9	11.3							
	C2	11.1	11.6							
	C3	11.4	11.9							
HZK12L	A1	11.6	12.1	0.5	80	0.5	1	10.5	7.0	0.5
	A2	11.9	12.4							
	A3	12.2	12.7							
	B1	12.4	12.9							
	B2	12.6	13.1							
	B3	12.9	13.4							
	C1	13.2	13.7							
	C2	13.5	14.0							
	C3	13.8	14.3							

Note:

(1) When placing an order for HZK-L type, enter suffix as follows: HZK6A1L, HZK6A2L.....HZK36-3L



Zener Diodes 0.4 W

Type No.	Suffix ⁽¹⁾	Zener Voltage		Test Current	Maximum Dynamic Resistance			Maximum Reverse Current		Typical Temperature Coefficient *	
		V _Z (V)			r _d @ I _Z	I _R @ V _R	γ _Z (mV/ °C)	I _Z			
		min.	max.	(mA)					(Ω)	(mA)	(μA)

HZK-L Series, 0.4 W, Case Type : MiniMELF



HZK15L	1	14.1	14.7	0.5	80	0.5	1	13.0	9.0	0.5
	2	14.5	15.1							
	3	14.9	15.5							
HZK16L	1	15.3	15.9	0.5	80	0.5	1	14.0	10.0	0.5
	2	15.7	16.5							
	3	16.3	17.1							
HZK18L	1	16.9	17.7	0.5	80	0.5	1	15.0	12.0	0.5
	2	17.5	18.3							
	3	18.1	19.0							
HZK20L	1	18.8	19.7	0.5	100	0.5	1	18.0	14.0	0.5
	2	19.5	20.4							
	3	20.2	21.1							
HZK22L	1	20.9	21.9	0.5	100	0.5	1	20.0	16.0	0.5
	2	21.6	22.6							
	3	22.3	23.3							
HZK24L	1	22.9	24.0	0.5	120	0.5	1	22.0	18.0	0.5
	2	23.6	24.7							
	3	24.3	25.5							
HZK27L	1	25.2	26.6	0.5	150	0.5	1	24.0	20.0	0.5
	2	26.2	27.6							
	3	27.2	28.6							
HZK30L	1	28.2	29.6	0.5	200	0.5	1	27.0	23.0	0.5
	2	29.2	30.6							
	3	30.2	31.6							
HZK33L	1	31.2	32.6	0.5	250	0.5	1	30.0	26.0	0.5
	2	32.2	33.6							
	3	33.2	34.6							
HZK36L	1	34.2	35.7	0.5	300	0.5	1	33.0	30.0	0.5
	2	35.3	36.8							
	3	36.4	38.0							

Note:

(1) When placing an order for HZK-L type, enter suffix as follows: HZK6A1L, HZK6A2L....HZK36-3L

Zener Diodes 0.4 W

Type No.	Suffix ⁽¹⁾	Zener Voltage		Test Current	Maximum Dynamic Resistance			Maximum Reverse Current		Typical Temperature Coefficient *	
		V _Z (V)			I _{ZT} (mA)	r _d (Ω)	@ I _Z (mA)	I _R (μA)	@ V _R (V)	γ _Z (mV/ °C)	I _Z (mA)
		min.	max.								

HZS-L Series, 0.4 W, Case Type : DO-34



HZS6L	A1	5.2	5.5	0.5	150	0.5	1	2.0	2.0	0.5
	A2	5.3	5.6							
	A3	5.4	5.7							
	B1	5.5	5.8		80					
	B2	5.6	5.9							
	B3	5.7	6.0							
	C1	5.8	6.1		60					
	C2	6.0	6.3							
	C3	6.1	6.4							
HZS7L	A1	6.3	6.6	0.5	60	0.5	1	3.5	3.0	0.5
	A2	6.4	6.7							
	A3	6.6	6.9							
	B1	6.7	7.0							
	B2	6.9	7.2							
	B3	7.0	7.3							
	C1	7.2	7.6							
	C2	7.3	7.7							
	C3	7.5	7.9							
HZS9L	A1	7.7	8.1	0.5	60	0.5	1	6.0	7.0	0.5
	A2	7.9	8.3							
	A3	8.1	8.5							
	B1	8.3	8.7							
	B2	8.5	8.9							
	B3	8.7	9.1							
	C1	8.9	9.3							
	C2	9.1	9.5							
	C3	9.3	9.7							
HZS11L	A1	9.5	9.9	0.5	80	0.5	1	8.0	1.0	2.0
	A2	9.7	10.1							
	A3	9.9	10.3							
	B1	10.2	10.6							
	B2	10.4	10.8							
	B3	10.7	11.1							
	C1	10.9	11.3							
	C2	11.1	11.6							
	C3	11.4	11.9							
HZS12L	A1	11.6	12.1	0.5	80	0.5	1	10.5	10.0	0.5
	A2	11.9	12.4							
	A3	12.2	12.7							
	B1	12.4	12.9							
	B2	12.6	13.1							
	B3	12.9	13.4							
	C1	13.2	13.7							
	C2	13.5	14.0							
	C3	13.8	14.3							

Note:

(1) When placing an order for HZS-L type, enter suffix as follows: HZS6A1, HZS6A2LHZS36-3L

Zener Diodes 0.4 W

Type No.	Suffix ⁽¹⁾	Zener Voltage		Test Current	Maximum Dynamic Resistance		Maximum Reverse Current		Typical Temperature Coefficient *	
		V _Z (V)			r _d @ I _Z	I _R @ V _R	γ _Z (mV/°C)	I _Z (mA)		
		min.	max.	(mA)					(Ω)	(mA)

HZS-L Series, 0.4 W, Case Type : DO-34



HZS15L	1	14.1	14.7	0.5	80	0.5	1	13.0	12.0	0.5
	2	14.5	15.1							
	3	14.9	15.5							
HZS16L	1	15.3	15.9	0.5	80	0.5	1	14.0	13.0	0.5
	2	15.7	16.5							
	3	16.3	17.1							
HZS18L	1	16.9	17.7	0.5	80	0.5	1	15.0	16.0	0.5
	2	17.5	18.3							
	3	18.1	19.0							
HZS20L	1	18.8	19.7	0.5	100	0.5	1	18.0	18.0	0.5
	2	19.5	20.4							
	3	20.2	21.1							
HZS22L	1	20.9	21.9	0.5	100	0.5	1	20.0	20.0	0.5
	2	21.6	22.6							
	3	22.3	23.3							
HZS24L	1	22.9	24.0	0.5	120	0.5	1	22.0	23.0	0.5
	2	23.6	24.7							
	3	24.3	25.5							
HZS27L	1	25.2	26.6	0.5	150	0.5	1	24.0	26.0	0.5
	2	26.2	27.6							
	3	27.2	28.6							
HZS30L	1	28.2	29.6	0.5	200	0.5	1	27.0	29.0	0.5
	2	29.2	30.6							
	3	30.2	31.6							
HZS33L	1	31.2	32.6	0.5	250	0.5	1	30.0	32.0	0.5
	2	32.2	33.6							
	3	33.2	34.6							
HZS36L	1	34.2	35.7	0.5	300	0.5	1	33.0	36.0	0.5
	2	35.3	36.8							
	3	36.4	38.0							

Note:

(1) When placing an order for HZS-L type, enter suffix as follows: HZS6A1, HZS6A2LHZS36-3L



Zener Diodes 0.4 W

Type	Suffix ⁽³⁾	Zener Voltage ⁽¹⁾		Test Current	Maximum Zener ⁽²⁾ Impedance			Maximum Reverse Current	
		V_Z (V) at I_{ZT}			Z_{ZT} @ I_{ZT}	Z_{ZK} @ I_{ZK}	I_{ZK}	I_R	at V_R
		min.	max.	(mA)	(Ω)	(Ω)	(mA)	(μ A)	(V)

RD2.0ES Series, 0.4 W, Case Type : DO-34



RD2.0ES	AB	1.88	2.20	5	100	1000	0.5	120	0.5
	AB1	1.88	2.10						
	AB2	2.02	2.20						
RD2.2ES	AB	2.12	2.41	5	100	1000	0.5	120	0.7
	AB1	2.12	2.30						
	AB2	2.22	2.41						
RD2.4ES	AB	2.33	2.63	5	100	1000	0.5	120	1.0
	AB1	2.33	2.52						
	AB2	2.43	2.63						
RD2.7ES	AB	2.54	2.91	5	110	1000	0.5	100	1.0
	AB1	2.54	2.75						
	AB2	2.69	2.91						
RD3.0ES	AB	2.85	3.22	5	120	1000	0.5	50	1.0
	AB1	2.85	3.07						
	AB2	3.01	3.22						
RD3.3ES	AB	3.16	3.53	5	120	1000	0.5	20	1.0
	AB1	3.16	3.38						
	AB2	3.32	3.53						
RD3.6ES	AB	3.47	3.83	5	120	1100	0.5	10	1.0
	AB1	3.47	3.68						
	AB2	3.62	3.83						
RD3.9ES	AB	3.77	4.14	5	120	1200	0.5	5	1.0
	AB1	3.77	3.98						
	AB2	3.92	4.14						
RD4.3ES	AB	4.05	4.53	5	120	1200	0.5	5	1.0
	AB1	4.05	4.26						
	AB2	4.20	4.40						
	AB3	4.34	4.53						
RD4.7ES	AB	4.47	4.91	5	100	1200	0.5	5	1.0
	AB1	4.47	4.65						
	AB2	4.59	4.77						
	AB3	4.71	4.91						
RD5.1ES	AB	4.85	5.35	5	70	1200	0.5	5	1.5
	AB1	4.85	5.03						
	AB2	4.97	5.18						
	AB3	5.12	5.35						
RD5.6ES	AB	5.29	5.88	5	40	900	0.5	5	2.5
	AB1	5.29	5.52						
	AB2	5.46	5.70						
	AB3	5.64	5.88						
RD6.2ES	AB	5.81	6.40	5	30	500	0.5	5	3.0
	AB1	5.81	6.06						
	AB2	5.99	6.24						
	AB3	6.16	6.40						



Zener Diodes 0.4 W

Type	Suffix ⁽³⁾	Zener Voltage ⁽¹⁾		Test Current	Maximum Zener ⁽²⁾ Impedance			Maximum Reverse Current	
		V _Z (V) at I _{ZT}			Z _{ZT} @ I _{ZT}	Z _{ZK} @ I _{ZK}	I _{ZK}	I _R	at V _R
		min.	max.	(mA)	(Ω)	(Ω)	(mA)	(μA)	(V)

RD2.0ES Series, 0.4 W, Case Type : DO-34



RD6.8ES	AB	6.32	6.97	5	25	150	0.5	2	3.5
	AB1	6.32	6.59						
	AB2	6.52	6.79						
	AB3	6.70	6.97						
RD7.5ES	AB	6.88	7.64	5	25	120	0.5	0.5	4.0
	AB1	6.88	7.19						
	AB2	7.11	7.41						
	AB3	7.33	7.64						
RD8.2ES	AB	7.56	8.41	5	20	120	0.5	0.5	5.0
	AB1	7.56	7.90						
	AB2	7.82	8.15						
	AB3	8.07	8.41						
RD9.1ES	AB	8.33	9.29	5	20	120	0.5	0.5	6.0
	AB1	8.33	8.70						
	AB2	8.61	8.99						
	AB3	8.89	9.29						
RD10ES	AB	9.19	10.30	5	20	120	0.5	0.2	7.0
	AB1	9.19	9.59						
	AB2	9.48	9.90						
	AB3	9.82	10.30						
RD11ES	AB	10.18	11.26	5	20	120	0.5	0.2	8.0
	AB1	10.18	10.63						
	AB2	10.50	10.95						
	AB3	10.82	11.26						
RD12ES	AB	11.13	12.30	5	25	110	0.5	0.2	9.0
	AB1	11.13	11.63						
	AB2	11.50	11.92						
	AB3	11.80	12.30						
RD13ES	AB	12.18	13.62	5	25	110	0.5	0.2	10
	AB1	12.18	12.71						
	AB2	12.59	13.16						
	AB3	13.03	13.62						
RD15ES	AB	13.48	15.02	5	25	110	0.5	0.2	11
	AB1	13.48	14.09						
	AB2	13.95	14.56						
	AB3	14.42	15.02						
RD16ES	AB	14.87	16.50	5	25	150	0.5	0.2	12
	AB1	14.87	15.50						
	AB2	15.33	15.96						
	AB3	15.79	16.50						
RD18ES	AB	16.34	18.30	5	30	150	0.5	0.2	13
	AB1	16.34	17.06						
	AB2	16.90	17.67						
	AB3	17.51	18.30						

Zener Diodes 0.4 W

Type	Suffix ⁽³⁾	Zener Voltage ⁽¹⁾		Test Current	Maximum Zener ⁽²⁾ Impedance			Maximum Reverse Current	
		V_Z (V) at I_{ZT}			Z_{ZT} @ I_{ZT}	Z_{ZK} @ I_{ZK}	I_{ZK}	I_R	at V_R
		min.	max.	(mA)	(Ω)	(Ω)	(mA)	(μ A)	(V)

RD2.0ES Series, 0.4 W, Case Type : DO-34



RD20ES	AB	18.14	20.45	5	30	200	0.5	0.2	15
	AB1	18.14	18.96						
	AB2	18.80	19.68						
	AB3	19.52	20.45						
RD22ES	AB	20.23	22.61	5	30	200	0.5	0.2	17
	AB1	20.23	21.08						
	AB2	20.76	21.65						
	AB3	21.22	22.09						
RD24ES	AB	22.26	24.81	5	30	200	0.5	0.2	19
	AB1	22.26	23.12						
	AB2	22.75	23.73						
	AB3	23.29	24.27						
RD27ES	AB	24.26	27.64	5	45	250	0.5	0.2	21
	AB1	24.26	25.52						
	AB2	24.97	26.26						
	AB3	25.63	26.95						
RD30ES	AB	26.99	30.51	5	55	250	0.5	0.2	23
	AB1	26.99	28.39						
	AB2	27.70	29.13						
	AB3	28.36	29.82						
RD33ES	AB	29.68	33.11	5	65	250	0.5	0.2	25
	AB1	29.68	31.22						
	AB2	30.32	31.88						
	AB3	30.90	32.50						
RD36ES	AB	32.14	35.77	5	75	250	0.5	0.2	27
	AB1	32.14	33.79						
	AB2	32.79	34.49						
	AB3	33.40	35.13						
RD39ES	AB	34.68	38.52	5	85	250	0.5	0.2	30
	AB1	34.68	36.47						
	AB2	35.36	37.19						
	AB3	36.00	37.85						
	AB4	36.63	38.52						

Notes :

(1) Tested with pulse (40 ms)

(2) Z_Z and Z_{ZK} are measured at I_Z by applying a very small AC current signal

(3) When placing an order for an RD2.0ES type, please add suffix e.g. RD2.0ESAB, RD2.0ESAB1... RD39ESAB4



Zener Diodes 0.4 W

Type No.	Suffix ⁽³⁾	Zener Voltage ⁽¹⁾			Dynamic Impedance		Knee Dynamic Impedance		Reverse Current	
		V _Z (V)			Z _Z (Ω)		Z _{ZK} (Ω)		I _R (μA)	
		Min.	Max.	I _Z (mA)	Max.	I _Z (mA)	Max.	I _Z (mA)	Max.	V _R (V)

RD4.7JS Series, 0.4 W, Case Type : DO-34



RD4.7JS	AB	4.42	4.90	5	100	5	800	0.5	2.0	1.0
	AB1	4.42	4.61							
	AB2	4.55	4.75							
	AB3	4.69	4.90							
RD5.1JS	AB	4.84	5.37	5	80	5	500	0.5	2.0	1.5
	AB1	4.84	5.04							
	AB2	4.98	5.20							
	AB3	5.14	5.37							
RD5.6JS	AB	5.31	5.92	5	60	5	200	0.5	1.0	2.5
	AB1	5.31	5.55							
	AB2	5.49	5.73							
	AB3	5.67	5.92							
RD6.2JS	AB	5.86	6.53	5	60	5	100	0.5	1.0	3.0
	AB1	5.86	6.12							
	AB2	6.06	6.33							
	AB3	6.26	6.53							
RD6.8JS	AB	6.47	7.14	5	40	5	60	0.5	0.5	3.5
	AB1	6.47	6.73							
	AB2	6.65	6.93							
	AB3	6.86	7.14							
RD7.5JS	AB	7.06	7.84	5	30	5	60	0.5	0.5	4.0
	AB1	7.06	7.36							
	AB2	7.28	7.60							
	AB3	7.52	7.84							
RD8.2JS	AB	7.76	8.64	5	30	5	60	0.5	0.5	5.0
	AB1	7.76	8.10							
	AB2	8.02	8.36							
	AB3	8.28	8.64							
RD9.1JS	AB	8.56	9.55	5	30	5	60	0.5	0.5	6.0
	AB1	8.56	8.93							
	AB2	8.85	9.23							
	AB3	9.15	9.55							
RD10JS	AB	9.45	10.55	5	30	5	60	0.5	0.1	7.0
	AB1	9.45	9.87							
	AB2	9.77	10.21							
	AB3	10.11	10.55							
RD11JS	AB	10.44	11.56	5	30	5	60	0.5	0.1	8.0
	AB1	10.44	10.88							
	AB2	10.76	11.22							
	AB3	11.10	11.56							
RD12JS	AB	11.42	12.60	5	30	5	80	0.5	0.1	9.0
	AB1	11.42	11.90							
	AB2	11.74	12.24							
	AB3	12.08	12.60							
RD13JS	AB	12.47	13.69	5	37	5	80	0.5	0.1	10
	AB1	12.47	13.03							
	AB2	12.91	13.49							
	AB3	13.37	13.96							

Zener Diodes 0.4 W

Type No.	Suffix ⁽³⁾	Zener Voltage ⁽¹⁾			Dynamic Impedance		Knee Dynamic Impedance		Reverse Current	
		V _Z (V)			Z _Z (Ω)		Z _{ZK} (Ω)		I _R (μA)	
		Min.	Max.	I _Z (mA)	Max.	I _Z (mA)	Max.	I _Z (mA)	Max.	V _R (V)

RD4.7JS Series, 0.4 W, Case Type : DO-34



RD15JS	AB	13.84	15.52	5	42	5	80	0.5	0.1	11
	AB1	13.84	14.46							
	AB2	14.34	14.98							
	AB3	14.85	15.52							
RD16JS	AB	15.37	17.09	5	50	5	80	0.5	0.1	12
	AB1	15.37	16.01							
	AB2	15.85	16.51							
	AB3	16.35	17.09							
RD18JS	AB	16.94	19.03	5	65	5	80	0.5	0.1	13
	AB1	16.94	17.70							
	AB2	17.56	18.53							
	AB3	18.21	19.03							
RD20JS	AB	18.86	21.08	5	85	5	100	0.5	0.1	15
	AB1	18.86	19.70							
	AB2	19.52	20.39							
	AB3	20.21	21.08							
RD22JS	AB	20.88	23.17	5	100	5	100	0.5	0.1	17
	AB1	20.88	21.77							
	AB2	21.54	22.47							
	AB3	22.23	23.17							
RD24JS	AB	22.93	25.57	5	120	5	120	0.5	0.1	19
	AB1	22.93	23.96							
	AB2	23.72	24.78							
	AB3	24.54	25.57							
RD27JS	AB	25.20	28.61	5	150	5	150	0.5	0.1	21
	AB1	25.20	26.50							
	AB2	26.19	27.53							
	AB3	27.21	28.61							
RD30JS	AB	28.22	31.74	5	200	5	200	0.5	0.1	23
	AB1	28.22	29.66							
	AB2	29.19	30.69							
	AB3	30.20	31.74							
RD33JS	AB	32.18	34.83	5	250	5	250	0.5	0.1	25
	AB1	32.18	32.78							
	AB2	32.15	33.79							
	AB3	33.13	34.83							
RD36JS	AB	34.12	37.91	5	300	5	300	0.5	0.1	27
	AB1	34.12	35.86							
	AB2	35.07	36.87							
	AB3	36.07	37.91							
RD39JS	AB	37.04	40.99	5	360	5	360	0.5	0.1	30
	AB1	37.04	38.94							
	AB2	38.00	39.94							
	AB3	38.99	40.99							

Notes:

- (1) Tested with pulse (40 ms).
- (2) Z_Z and Z_{ZK} are measured at I_Z by applying a very small AC current signal.
- (3) When placing an order for an RD4.7JS type, please add suffix e.g. RD4.7JSAB, RD4.7JSAB1... RD39JSAB3



Zener Diodes 0.5 W

Type No.		Nominal Zener Voltage	Test Current	Maximum Zener Impedance ⁽¹⁾		Maximum Reverse Leakage Current		Typical Temperature Coefficient $\alpha_{VZ}(\%/^{\circ}\text{C})$	Maximum Regulator Current ⁽²⁾
		$V_Z @ I_{ZT}$	I_{ZT}	$Z_{ZT} @ I_{ZT}$	Z_{ZK} at $I_{ZK} = 0.25\text{mA}$	$I_R @ V_R$	V_R		I_{ZM}
Axial Lead	SMD	(V)	(mA)	(Ω)	(Ω)	(μA)	(V)		(mA)

1N5225/ZMM5225 Series, Case Type: DO-35 / MiniMELF



1N5221	ZMM5221	2.4	20	30	1200	100	1.0	-0.085	190
1N5222	ZMM5222	2.5	20	30	1250	100	1.0	-0.085	182
1N5223	ZMM5223	2.7	20	30	1300	75	1.0	-0.080	168
1N5224	ZMM5224	2.8	20	30	1400	75	1.0	-0.080	162
1N5225	ZMM5225	3.0	20	29	1600	50	1.0	-0.075	152
1N5226	ZMM5226	3.3	20	28	1600	25	1.0	-0.070	138
1N5227	ZMM5227	3.6	20	24	1700	15	1.0	-0.065	126
1N5228	ZMM5228	3.9	20	23	1900	10	1.0	-0.060	115
1N5229	ZMM5229	4.3	20	22	2000	5.0	1.0	-0.055	106
1N5230	ZMM5230	4.7	20	19	1900	5.0	2.0	± 0.030	97
1N5231	ZMM5231	5.1	20	17	1600	5.0	2.0	± 0.030	89
1N5232	ZMM5232	5.6	20	11	1600	5.0	3.0	+0.038	81
1N5233	ZMM5233	6.0	20	7	1600	5.0	3.5	+0.038	76
1N5234	ZMM5234	6.2	20	7	1000	5.0	4.0	+0.045	73
1N5235	ZMM5235	6.8	20	5	750	3.0	5.0	+0.050	67
1N5236	ZMM5236	7.5	20	6	500	3.0	6.0	+0.058	61
1N5237	ZMM5237	8.2	20	8	500	3.0	6.5	+0.062	55
1N5238	ZMM5238	8.7	20	8	600	3.0	6.5	+0.065	52
1N5239	ZMM5239	9.1	20	10	600	3.0	7.0	+0.068	50
1N5240	ZMM5240	10	20	17	600	3.0	8.0	+0.075	45
1N5241	ZMM5241	11	20	22	600	2.0	8.4	+0.076	41
1N5242	ZMM5242	12	20	30	600	1.0	9.1	+0.077	38
1N5243	ZMM5243	13	9.5	13	600	0.5	9.9	+0.079	35
1N5244	ZMM5244	14	9.0	15	600	0.1	10	+0.082	32
1N5245	ZMM5245	15	8.5	16	600	0.1	11	+0.082	30
1N5246	ZMM5246	16	7.8	17	600	0.1	12	+0.083	28
1N5247	ZMM5247	17	7.4	19	600	0.1	13	+0.084	27
1N5248	ZMM5248	18	7.0	21	600	0.1	14	+0.085	25
1N5249	ZMM5249	19	6.6	23	600	0.1	14	+0.086	24
1N5250	ZMM5250	20	6.2	25	600	0.1	15	+0.086	23
1N5251	ZMM5251	22	5.6	29	600	0.1	17	+0.087	21
1N5252	ZMM5252	24	5.2	33	600	0.1	18	+0.088	19.1
1N5253	ZMM5253	25	5.0	35	600	0.1	19	+0.089	18.2
1N5254	ZMM5254	27	4.6	41	600	0.1	21	+0.090	16.8
1N5255	ZMM5255	28	4.5	44	600	0.1	21	+0.091	16.2
1N5256	ZMM5256	30	4.2	49	600	0.1	23	+0.091	15.1
1N5257	ZMM5257	33	3.8	58	700	0.1	25	+0.092	13.8
1N5258	ZMM5258	36	3.4	70	700	0.1	27	+0.093	12.6
1N5259	ZMM5259	39	3.2	80	800	0.1	30	+0.094	11.6
1N5260	ZMM5260	43	3.0	93	900	0.1	33	+0.095	10.6
1N5261	ZMM5261	47	2.7	105	1000	0.1	36	+0.095	9.7
1N5262	ZMM5262	51	2.5	125	1100	0.1	39	+0.096	8.9
1N5263	ZMM5263	56	2.2	150	1300	0.1	43	+0.096	-
1N5264	ZMM5264	60	2.1	170	1400	0.1	46	+0.097	-
1N5265	ZMM5265	62	2.0	185	1400	0.1	47	+0.098	-
1N5266	ZMM5266	68	1.8	230	1600	0.1	52	+0.097	-
1N5267	ZMM5267	75	1.7	270	1700	0.1	56	+0.098	-

Notes :

- (1) The Zener impedance is derived from the 1 KHz AC voltage which results when an AC current having an RMS value equal to 10% of the Zener current (I_{ZT} or I_{ZK}) is superimposed on I_{ZT} or I_{ZK} . Zener impedance is measured at two points to ensure a sharp knee on the breakdown curve and to eliminate unstable units
- (2) $V_F = 1.1 V_{max}$. @ $I_F = 200 \text{ mA}$
- (3) Standard Zener voltage tolerance is $\pm 10\%$. Add suffix "B" for $\pm 5\%$ tolerance, Add suffix "C" for $\pm 2\%$ tolerance .



Zener Diodes 0.5 W

Type No.	Nominal Zener Voltage ⁽³⁾	Test Current	Maximum Zener Impedance	Maximum Reverse Leakage Current $I_R @ V_R=1V$		Maximum DC Zener Current ⁽²⁾
	$V_Z @ I_{ZT}$	I_{ZT}	$Z_{ZT} @ I_{ZT}^{(1)}$	$T_a=25^\circ C$	$T_a=150^\circ C$	I_{ZM}
	(V)	(mA)	(Ω)	(μA)	(μA)	(mA)

1N746A Series, 0.5 W, Case Type : DO-35



1N746A	3.3	20	28	10	30	110
1N747A	3.6	20	24	10	30	100
1N748A	3.9	20	23	10	30	95
1N749A	4.3	20	22	2	30	85
1N750A	4.7	20	19	2	30	75
1N751A	5.1	20	17	1	20	70
1N752A	5.6	20	11	1	20	65
1N753A	6.2	20	7	0.1	20	60
1N754A	6.8	20	5	0.1	20	55
1N755A	7.5	20	6	0.1	20	50
1N756A	8.2	20	8	0.1	20	45
1N757A	9.1	20	10	0.1	20	40
1N758A	10	20	17	0.1	20	35
1N759A	12	20	30	0.1	20	30

Notes :

- (1) The Zener impedance is derived from the 1 KHz AC voltage which results when an AC current having an RMS value equal to 10% of the Zener current (I_{ZT}) is superimposed on I_{ZT} . Zener impedance is measured at two points to ensure a sharp knee on the breakdown curve and to eliminate unstable units
- (2) Valid provided that leads are at a distance of 3/8" from case and kept at ambient temperature.
- (3) Measured with device junction in thermal equilibrium
- (4) Standard zener voltage tolerance is $\pm 5\%$ for suffix "A". Other tolerances are available upon request
- (5) $V_F = 1.5 V_{max}$. @ $I_F = 200 mA$



Zener Diodes 0.5 W

Type No.	Zener Voltage $V_Z @ I_{ZT}^{(3)}$		Maximum Zener Impedance ⁽¹⁾			Maximum Reverse Leakage Current		Maximum DC Zener Current
	Nominal	I_{ZT}	$Z_{ZT} @ I_{ZT}$	$Z_{ZK} @ I_{ZK}$	I_{ZK}	$I_R @ V_R$	$I_{ZM}^{(2)}$	
	(V)	(mA)	(Ω)	(Ω)	(mA)	(μ A) (V)	(mA)	

1N957B Series, 0.5 W, Case Type : DO-35



1N957B	6.8	18.5	4.5	700	1.00	150	5.2	58
1N958B	7.5	16.5	5.5	700	0.50	75	5.7	53
1N959B	8.2	15.0	6.5	700	0.50	50	6.2	47
1N960B	9.1	14.0	7.5	700	0.50	25	6.9	43
1N961B	10	12.5	8.5	700	0.25	10	7.6	40
1N962B	11	11.5	9.5	700	0.25	5	8.4	36
1N963B	12	10.5	11.5	700	0.25	5	9.1	32
1N964B	13	9.5	13	700	0.25	5	9.9	29
1N965B	15	8.5	16	700	0.25	5	11.4	27
1N966B	16	7.8	17	700	0.25	5	12.2	24
1N967B	18	7.0	21	750	0.25	5	13.7	21
1N968B	20	6.2	25	750	0.25	5	15.2	20
1N969B	22	5.6	29	750	0.25	5	16.7	18
1N970B	24	5.2	33	750	0.25	5	18.2	16
1N971B	27	4.6	41	750	0.25	5	20.6	14
1N972B	30	4.2	49	1000	0.25	5	22.8	13
1N973B	33	3.8	58	1000	0.25	5	25.1	12
1N974B	36	3.4	70	1000	0.25	5	27.4	11
1N975B	39	3.2	80	1000	0.25	5	29.7	10
1N976B	43	3.0	93	1500	0.25	5	32.7	9.2
1N977B	47	2.7	105	1500	0.25	5	35.8	8.5
1N978B	51	2.5	125	1500	0.25	5	38.8	7.8
1N979B	56	2.2	150	2000	0.25	5	42.6	6.9
1N980B	62	2.0	185	2000	0.25	5	47.1	6.3
1N981B	68	1.8	230	2000	0.25	5	51.7	5.7
1N982B	75	1.7	270	2000	0.25	5	56.0	5.2
1N983B	82	1.5	330	3000	0.25	5	62.2	4.7
1N984B	91	1.4	440	3000	0.25	5	69.2	4.3

Notes :

- (1) The Zener Impedance is derived from the 1 KHz AC voltage which results when an AC current having an RMS value equal to 10% of the Zener current (I_{ZT}) is superimposed on I_{ZT} . Zener Impedance is measured at two points to ensure a sharp knee on the breakdown curve and to eliminate unstable units.
- (2) Valid provided that leads are at a distance of 3/8" from case and kept at 25°C ambient temperature.
- (3) Measured with device junction in thermal equilibrium.
- (4) Standard zener voltage tolerance is $\pm 5\%$ for suffix "B". Other tolerances are available upon request.
- (5) $V_F = 1.5 V_{max.} @ I_F = 200 \text{ mA}$



Zener Diodes 0.5 W

Type No.	Zener Voltage $V_Z @ I_{ZT}$				Maximum Zener Impedance			Maximum Reverse Leakage Current, I_R			Temp. coefficient of Zener Voltage at $I_Z = 5\text{mA}$ $\alpha_{VZ}(\% / \text{C})$	Admissible Zener Current ⁽²⁾ $I_{ZM}(\text{mA})$
	Nom ⁽¹⁾	Min	Max	I_{ZT}	$Z_{ZT} @ I_{ZT}$	$Z_{Zk} @ I_{Zk}$	I_{Zk}	$T_a=25^\circ\text{C}$	$T_a=150^\circ\text{C}$	At V_R		
	(V)	(V)	(V)	(mA)	(Ω)	(Ω)	(mA)	(μA)	(μA)	(V)		

BZX55 Series, 0.5 W, Case Type : DO-35



BZX55C2V0	2.0	1.90	2.10	5.0	85	600	1.0	100	200	1.0	-0.09...-0.06	175
BZX55C2V2	2.2	2.09	2.31	5.0	85	600	1.0	50	100	1.0	-0.09...-0.06	160
BZX55C2V4	2.4	2.28	2.56	5.0	85	600	1.0	50	100	1.0	-0.09...-0.06	145
BZX55C2V7	2.7	2.5	2.9	5.0	85	600	1.0	10	50	1.0	-0.09...-0.06	135
BZX55C3V0	3.0	2.8	3.2	5.0	85	600	1.0	4	40	1.0	-0.08...-0.05	125
BZX55C3V3	3.3	3.1	3.5	5.0	85	600	1.0	2	40	1.0	-0.08...-0.05	115
BZX55C3V6	3.6	3.4	3.8	5.0	85	600	1.0	2	40	1.0	-0.08...-0.05	105
BZX55C3V9	3.9	3.7	4.1	5.0	85	600	1.0	2	40	1.0	-0.08...-0.05	95
BZX55C4V3	4.3	4.0	4.6	5.0	75	600	1.0	1	20	1.0	-0.06...-0.03	90
BZX55C4V7	4.7	4.4	5.0	5.0	60	600	1.0	0.5	10	1.0	-0.05...+0.02	85
BZX55C5V1	5.1	4.8	5.4	5.0	35	550	1.0	0.1	2	1.0	-0.02...+0.02	80
BZX55C5V6	5.6	5.2	6.0	5.0	25	450	1.0	0.1	2	1.0	-0.05...+0.05	70
BZX55C6V2	6.2	5.8	6.6	5.0	10	200	1.0	0.1	2	2.0	0.03...0.06	64
BZX55C6V8	6.8	6.4	7.2	5.0	8	150	1.0	0.1	2	3.0	0.03...0.07	58
BZX55C7V5	7.5	7.0	7.9	5.0	7	50	1.0	0.1	2	5.0	0.03...0.07	53
BZX55C8V2	8.2	7.7	8.7	5.0	7	50	1.0	0.1	2	6.2	0.03...0.08	47
BZX55C9V1	9.1	8.5	9.6	5.0	10	50	1.0	0.1	2	6.8	0.03...0.09	43
BZX55C10	10	9.4	10.6	5.0	15	70	1.0	0.1	2	7.5	0.03...0.10	40
BZX55C11	11	10.4	11.6	5.0	20	70	1.0	0.1	2	8.2	0.03...0.11	36
BZX55C12	12	11.4	12.7	5.0	20	90	1.0	0.1	2	9.1	0.03...0.11	32
BZX55C13	13	12.4	14.1	5.0	26	110	1.0	0.1	2	10	0.03...0.11	29
BZX55C15	15	13.8	15.6	5.0	30	110	1.0	0.1	2	11	0.03...0.11	28
BZX55C16	16	15.3	17.1	5.0	40	170	1.0	0.1	2	12	0.03...0.11	27
BZX55C18	18	16.8	19.1	5.0	50	170	1.0	0.1	2	13	0.03...0.11	24
BZX55C20	20	18.8	21.2	5.0	55	220	1.0	0.1	2	15	0.03...0.11	21
BZX55C22	22	20.8	23.3	5.0	55	220	1.0	0.1	2	16	0.04...0.12	20
BZX55C24	24	22.8	25.6	5.0	80	220	1.0	0.1	2	18	0.04...0.12	18
BZX55C27	27	25.1	28.9	5.0	80	220	1.0	0.1	2	20	0.04...0.12	16
BZX55C30	30	28	32	5.0	80	220	1.0	0.1	2	22	0.04...0.12	14
BZX55C33	33	31	35	5.0	80	220	1.0	0.1	2	24	0.04...0.12	13
BZX55C36	36	34	38	5.0	80	220	1.0	0.1	2	27	0.04...0.12	12
BZX55C39	39	37	41	2.5	90	500	0.5	0.1	5	30	0.04...0.12	11
BZX55C43	43	40	46	2.5	90	500	0.5	0.1	5	33	0.04...0.12	10
BZX55C47	47	44	50	2.5	110	600	0.5	0.1	5	36	0.04...0.12	9.2
BZX55C51	51	48	54	2.5	125	700	0.5	0.1	10	39	0.04...0.12	8.5
BZX55C56	56	52	60	2.5	135	700	0.5	0.1	10	43	typ. 0.1 ⁽⁴⁾	7.8
BZX55C62	62	58	66	2.5	150	1000	0.5	0.1	10	47	typ. 0.1 ⁽⁴⁾	7.0
BZX55C68	68	64	72	2.5	200	1000	0.5	0.1	10	51	typ. 0.1 ⁽⁴⁾	6.4
BZX55C75	75	70	79	2.5	250	1000	0.5	0.1	10	56	typ. 0.1 ⁽⁴⁾	5.9
BZX55C82	82	77	87	2.5	300	1500	0.5	0.1	10	62	typ. 0.1 ⁽⁴⁾	5.3
BZX55C91	91	85	96	1.0	450	2000	0.1	0.1	10	68	typ. 0.1 ⁽⁴⁾	4.8
BZX55C100	100	94	106	1.0	450	5000	0.1	0.1	10	75	typ. 0.1 ⁽⁴⁾	4.4

Notes:

- (1) Tested with pulse $t_p = 20\text{ms}$
- (2) Valid provided that leads are kept at ambient temperature at a distance of 8 mm from case
- (3) For $\pm 2\%$ tolerance replace the sixth letter of the type from "C" to "B" e.g. BZX55B15
- (4) At $I_Z = 2.5\text{mA}$
- (5) $V_F = 1\text{Vmax.} @ I_F = 100\text{mA}$



Zener Diodes 0.5 W

Type No.	Zener Voltage $V_Z @ I_{ZT}$		Maximum Zener Impedance, $f = 1\text{kHz}$			Maximum Reverse Leakage Current		Temp. coefficient of Zener Voltage at I_{ZT}
	Nom ⁽¹⁾	I_{ZT}	$Z_{ZT} @ I_{ZT}$	$Z_{ZK} @ I_{ZK}$	I_{ZK}	I_R	at V_R	
	(V)	(mA)	(Ω)	(Ω)	(mA)	(μA)	(V)	

BZV55 Series, 0.5 W, Case Type : MiniMELF



BZV55C2V4	2.4	5	100	600	1.0	50	1	-0.08...-0.06
BZV55C2V7	2.7	5	100	600	1.0	20	1	-0.08...-0.06
BZV55C3V0	3.0	5	95	600	1.0	10	1	-0.08...-0.05
BZV55C3V3	3.3	5	95	600	1.0	5	1	-0.08...-0.05
BZV55C3V6	3.6	5	90	600	1.0	5	1	-0.08...-0.04
BZV55C3V9	3.9	5	90	600	1.0	3	1	-0.07...-0.03
BZV55C4V3	4.3	5	90	600	1.0	3	1	-0.04...-0.01
BZV55C4V7	4.7	5	80	500	1.0	3	2	-0.03...+0.01
BZV55C5V1	5.1	5	60	480	1.0	2	2	-0.02...+0.05
BZV55C5V6	5.6	5	40	400	1.0	1	2	-0.01...+0.06
BZV55C6V2	6.2	5	10	150	1.0	3	4	0.00...0.07
BZV55C6V8	6.8	5	15	80	1.0	2	4	0.01...0.08
BZV55C7V5	7.5	5	15	80	1.0	1	5	0.01...0.09
BZV55C8V2	8.2	5	15	80	1.0	0.7	5	0.01...0.09
BZV55C9V1	9.1	5	15	100	1.0	0.5	6	0.02...0.10
BZV55C10	10	5	20	150	1.0	0.2	7	0.03...0.11
BZV55C11	11	5	20	150	1.0	0.1	8	0.03...0.11
BZV55C12	12	5	25	150	1.0	0.1	8	0.03...0.11
BZV55C13	13	5	30	170	1.0	0.1	8	0.03...0.11
BZV55C15	15	5	30	200	1.0	0.05	10	0.03...0.11
BZV55C16	16	5	40	200	1.0	0.05	11	0.03...0.11
BZV55C18	18	5	45	225	1.0	0.05	13	0.03...0.11
BZV55C20	20	5	55	225	1.0	0.05	14	0.03...0.11
BZV55C22	22	5	55	250	1.0	0.05	15	0.03...0.11
BZV55C24	24	5	70	250	1.0	0.05	17	0.04...0.12
BZV55C27	27	2	80	300	0.5	0.05	19	0.04...0.12
BZV55C30	30	2	80	300	0.5	0.05	21	0.04...0.12
BZV55C33	33	2	80	325	0.5	0.05	23	0.04...0.12
BZV55C36	36	2	90	350	0.5	0.05	25	0.04...0.12
BZV55C39	39	2	130	350	0.5	0.05	27	0.04...0.12
BZV55C43	43	2	150	375	0.5	0.05	30	0.04...0.12
BZV55C47	47	2	170	375	0.5	0.05	33	0.04...0.12
BZV55C51	51	2	180	400	0.5	0.05	36	0.04...0.12
BZV55C56	56	2	200	425	0.5	0.05	39	0.1 (typ.)
BZV55C62	62	2	215	450	0.5	0.05	43	0.1 (typ.)
BZV55C68	68	2	240	475	0.5	0.05	48	0.1 (typ.)
BZV55C75	75	2	255	500	0.5	0.05	53	0.1 (typ.)

Notes.

- (1) Tested with pulse $t_p = 5\text{ ms}$
- (2) The type numbers listed have a standard tolerance on the nominal zener voltage of $\pm 5\%$
For $\pm 2\%$ tolerance replace the sixth letter of the type from "C" to "B" e.g. BZV55B15
- (3) $V_F = 0.9 V_{max}$. @ $I_F = 10\text{ mA}$

Zener Diodes 0.5 W

Type No.	Zener Voltage $V_Z @ I_{ZT}$		Maximum Zener Impedance, $f = 1\text{kHz}$			Maximum Reverse Leakage Current		Temp. coefficient of Zener Voltage at I_{ZT}	Admissible Zener Current ⁽²⁾	Maximum Capacitance $V_R=0, f=1\text{MHz}$
	Nom ⁽¹⁾	I_{ZT}	$Z_{ZT} @ I_{ZT}$	$Z_{Zk} @ I_{Zk}$	I_{Zk}	I_R	at V_R			
	(V)	(mA)	(Ω)	(Ω)	(mA)	(μA)	(V)	$\alpha_{mvz}(\% / ^\circ\text{C})$	(mA)	(pF)

BZX79 Series, 0.5 W, Case Type : DO-35



BZX79C2V4	2.4	5	100	600	1	50	1	-0.08...-0.06	167	450
BZX79C2V7	2.7	5	100	600	1	20	1	-0.08...-0.06	135	450
BZX79C3V0	3.0	5	95	600	1	10	1	-0.08...-0.05	125	450
BZX79C3V3	3.3	5	95	600	1	5	1	-0.08...-0.05	115	450
BZX79C3V6	3.6	5	90	600	1	5	1	-0.08...-0.04	105	450
BZX79C3V9	3.9	5	90	600	1	3	1	-0.07...-0.03	95	450
BZX79C4V3	4.3	5	90	600	1	3	1	-0.04...-0.01	90	450
BZX79C4V7	4.7	5	80	500	1	3	1	-0.03...+0.01	85	300
BZX79C5V1	5.1	5	60	480	1	2	1	-0.02...+0.05	80	300
BZX79C5V6	5.6	5	40	400	1	1	1	-0.01...+0.06	70	300
BZX79C6V2	6.2	5	10	150	1	3	2	0.00...0.07	64	200
BZX79C6V8	6.8	5	15	80	1	2	3	0.01...0.08	58	200
BZX79C7V5	7.5	5	15	80	1	1	5	0.01...0.09	53	150
BZX79C8V2	8.2	5	15	80	1	0.7	6	0.01...0.09	47	150
BZX79C9V1	9.1	5	15	100	1	0.5	7	0.02...0.10	43	150
BZX79C10	10	5	20	150	1	0.2	7.5	0.03...0.11	40	90
BZX79C11	11	5	20	150	1	0.1	8.5	0.03...0.11	36	85
BZX79C12	12	5	25	150	1	0.1	9	0.03...0.11	32	85
BZX79C13	13	5	30	170	1	0.1	10	0.03...0.11	29	80
BZX79C15	15	5	30	200	1	0.05	11	0.03...0.11	27	75
BZX79C16	16	5	40	200	1	0.05	12	0.03...0.11	24	75
BZX79C18	18	5	45	225	1	0.05	14	0.03...0.11	21	70
BZX79C20	20	5	55	225	1	0.05	15	0.03...0.11	20	60
BZX79C22	22	5	55	250	1	0.05	17	0.03...0.11	18	60
BZX79C24	24	5	70	250	1	0.05	18	0.04...0.12	16	55
BZX79C27	27	2	80	300	0.5	0.05	20	0.04...0.12	14	50
BZX79C30	30	2	80	300	0.5	0.05	22	0.04...0.12	13	50
BZX79C33	33	2	80	325	0.5	0.05	24	0.04...0.12	12	45
BZX79C36	36	2	90	350	0.5	0.05	27	0.04...0.12	11	45
BZX79C39	39	2	130	350	0.5	0.05	28	0.04...0.12	10	45
BZX79C43	43	2	150	375	0.5	0.05	32	0.04...0.12	9.2	40
BZX79C47	47	2	170	375	0.5	0.05	35	0.04...0.12	8.5	40
BZX79C51	51	2	180	400	0.5	0.05	38	0.04...0.12	7.8	40
BZX79C56	56	2	200	425	0.5	0.05	39	0.1(typ.)	7.1	40
BZX79C62	62	2	215	450	0.5	0.05	43	0.1(typ.)	6.4	35
BZX79C68	68	2	240	475	0.5	0.05	48	0.1(typ.)	5.8	35
BZX79C75	75	2	255	500	0.5	0.05	53	0.1(typ.)	5.3	35

Notes:

- (1) Tested with pulse $t_p = 5\text{ms}$
- (2) Valid provided that leads are kept at ambient temperature at a distance of 8 mm from case
- (3) The type numbers listed have a standard tolerance on the nominal zener voltage of $\pm 5\%$
For $\pm 2\%$ tolerance replace the sixth letter of the type from "C" to "B" e.g. BZX79B13
- (4) $V_F = 0.9 V_{max}$. @ $I_F = 10\text{mA}$



Zener Diodes 0.5 W

Type No.	Suffix ⁽²⁾	Zener Voltage		Test Current	Maximum Zener Impedance , f = 1kHz			Maximum Reverse Current	
		V _Z (V) at I _{ZT} ⁽¹⁾			I _{ZT}	Z _{ZT} @ I _{ZT}	Z _{ZK} @ I _{ZK}	I _{ZK}	I _R
		min.	max.	(mA)	(Ω)	(Ω)	(mA)	(μA)	(V)

GLZ Series, 0.5 W, Case Type : MiniMELF



GLZ3.3	A	3.160	3.380	20	70	1000	1	20	1
	B	3.320	3.530						
GLZ3.6	A	3.455	3.695	20	60	1000	1	10	1
	B	3.600	3.845						
GLZ3.9	A	3.74	4.01	20	50	1000	1	5	1
	B	3.89	4.16						
GLZ4.3	A	4.04	4.29	20	40	1000	1	5	1
	B	4.17	4.43						
	C	4.30	4.57						
GLZ4.7	A	4.44	4.68	20	25	900	1	5	1
	B	4.55	4.80						
	C	4.68	4.93						
GLZ5.1	A	4.81	5.07	20	20	800	1	5	1.5
	B	4.94	5.20						
	C	5.09	5.37						
GLZ5.6	A	5.28	5.55	20	13	500	1	5	2.5
	B	5.45	5.73						
	C	5.61	5.91						
GLZ6.2	A	5.78	6.09	20	10	300	1	5	3
	B	5.96	6.27						
	C	6.12	6.44						
GLZ6.8	A	6.29	6.63	20	8	150	0.5	2	3.5
	B	6.49	6.83						
	C	6.66	7.01						
GLZ7.5	A	6.85	7.22	20	8	120	0.5	0.5	4
	B	7.07	7.45						
	C	6.29	7.67						
GLZ8.2	A	7.53	7.92	20	8	120	0.5	0.5	5
	B	7.78	8.19						
	C	8.03	8.45						
GLZ9.1	A	8.29	8.73	20	8	120	0.5	0.5	6
	B	8.57	9.01						
	C	8.83	9.30						
GLZ10	A	9.12	9.59	20	8	120	0.5	0.2	7
	B	9.41	9.90						
	C	9.70	10.20						
	D	9.94	10.44						
GLZ11	A	10.18	10.71	20	10	120	0.5	0.2	8
	B	10.50	115.00						
	C	10.82	11.38						
GLZ12	A	11.13	11.71	20	12	110	0.5	0.2	9
	B	11.44	12.03						
	C	11.74	12.35						
GLZ13	A	12.11	12.75	10	14	110	0.5	0.2	10
	B	12.55	13.21						
	C	12.99	13.66						

Zener Diodes 0.5 W

Type No.	Suffix ⁽²⁾	Zener Voltage		Test Current	Maximum Zener Impedance , f = 1kHz			Maximum Reverse Current	
		V _Z (V) at I _{ZT} ⁽¹⁾			I _{ZT}	Z _{ZT} @ I _{ZT}	Z _{ZK} @ I _{ZK}	I _{ZK}	I _R
		min.	max.	(mA)	(Ω)	(Ω)	(mA)	(μA)	(V)

GLZ Series, 0.5 W, Case Type : MiniMELF



GLZ15	A	13.45	14.13	10	16	110	0.5	0.2	11
	B	13.89	14.62						
	C	14.35	15.09						
GLZ16	A	14.80	15.57	10	18	150	0.5	0.2	12
	B	15.25	16.04						
	C	15.69	16.51						
GLZ18	A	16.22	17.06	10	23	150	0.5	0.2	13
	B	16.82	17.70						
	C	17.42	18.33						
GLZ20	A	18.02	18.96	10	28	200	0.5	0.2	15
	B	18.63	19.59						
	C	19.23	20.22						
	D	19.72	20.72						
GLZ22	A	20.15	21.20	5	30	200	0.5	0.2	17
	B	20.64	21.71						
	C	21.08	22.17						
	D	21.52	22.63						
GLZ24	A	22.05	23.18	5	35	200	0.5	0.2	19
	B	22.61	23.77						
	C	23.12	24.31						
	D	23.63	24.85						
GLZ27	A	24.26	25.52	5	45	200	0.5	0.2	21
	B	24.97	26.26						
	C	25.63	26.95						
	D	26.29	27.54						
GLZ30	A	26.99	28.39	5	55	250	0.5	0.2	23
	B	27.70	29.13						
	C	28.36	29.82						
	D	29.20	30.51						
GLZ33	A	29.68	31.22	5	65	250	0.5	0.2	25
	B	30.32	31.88						
	C	30.90	32.50						
	D	31.49	33.11						
GLZ36	A	31.14	33.79	5	75	250	0.5	0.2	27
	B	32.76	34.49						
	C	33.40	35.13						
	D	34.01	35.77						
GLZ39	A	34.68	36.47	5	85	250	0.5	0.2	30
	B	35.36	37.19						
	C	36.00	37.85						
	D	36.63	38.52						

Notes:

- (1) The Zener voltage is measured 40ms after power is supplied
- (2) When ordering use suffix "A", "B", "C" or "D" to specify zener voltage e.g. GLZ3.3A....GLZ39D



Zener Diodes 0.5 W

Type No.	Grade	Zener Voltage $V_Z @ I_{ZT}$						Test Current	Maximum Dynamic Resistance		Maximum Reverse Current	
		Suffix -1		Suffix -2		Suffix -3			I_{ZT}	rd @ I_Z	$I_R @ V_R$	(μA)
		min.	max.	min.	max.	min.	max.	(mA)				

HZ Series, 0.5 W, Case Type : DO-35



HZ2	A	1.6	1.8	1.7	1.9	1.8	2.0	5	100	5	25	0.5
	B	1.9	2.1	2.0	2.2	2.1	2.3	5	100	5	2	0.5
	C	2.2	2.4	2.3	2.5	2.4	2.6	5	100	5	1	0.5
HZ3	A	2.5	2.7	2.6	2.8	2.7	2.9	5	100	5	1	0.5
	B	2.8	3.0	2.9	3.1	3.0	3.2	5	100	5	1	0.5
	C	3.1	3.3	3.2	3.4	3.3	3.5	5	100	5	1	0.5
HZ4	A	3.4	3.6	3.5	3.7	3.6	3.8	5	100	5	5	1
	B	3.7	3.9	3.8	4.0	3.9	4.1	5	100	5	5	1
	C	4.0	4.2	4.1	4.3	4.2	4.4	5	100	5	5	1
HZ5	A	4.3	4.5	4.4	4.6	4.5	4.7	5	100	5	5	1.5
	B	4.6	4.8	4.7	4.9	4.8	5.0	5	100	5	5	1.5
	C	4.9	5.1	5.0	5.2	5.1	5.3	5	100	5	5	1.5
HZ6	A	5.2	5.5	5.3	5.6	5.4	5.7	5	35	5	5	2
	B	5.5	5.8	5.6	5.9	5.7	6.0	5	35	5	5	2
	C	5.8	6.1	6.0	6.3	6.1	6.4	5	35	5	5	2
HZ7	A	6.3	6.6	6.4	6.7	6.6	6.9	5	15	5	1	3.5
	B	6.7	7.0	6.9	7.2	7.0	7.3	5	15	5	1	3.5
	C	7.2	7.6	7.3	7.7	7.5	7.9	5	15	5	1	3.5
HZ9	A	7.7	8.1	7.9	8.3	8.1	8.5	5	20	5	1	5
	B	8.3	8.7	8.5	8.9	8.7	9.1	5	20	5	1	5
	C	8.9	9.3	9.1	9.5	9.3	9.7	5	20	5	1	5
HZ11	A	9.5	9.9	9.7	10.1	9.9	10.3	5	25	5	1	7.5
	B	10.2	10.6	10.4	10.8	10.7	11.1	5	25	5	1	7.5
	C	10.9	11.3	11.1	11.6	11.4	11.9	5	25	5	1	7.5
HZ12	A	11.6	12.1	11.9	12.4	12.2	12.7	5	35	5	1	9.5
	B	12.4	12.9	12.6	13.1	12.9	13.4	5	35	5	1	9.5
	C	13.2	13.7	13.5	14.0	13.8	14.3	5	35	5	1	9.5
HZ15		14.1	14.7	14.5	15.1	14.9	15.5	5	40	5	1	11
HZ16		15.3	15.9	15.7	16.5	16.3	17.1	5	45	5	1	12
HZ18		16.9	17.7	17.5	18.3	18.1	19.0	5	55	5	1	13
HZ20		18.8	19.7	19.5	20.4	20.2	21.1	2	60	2	1	15
HZ22		20.9	21.9	21.6	22.6	22.3	23.3	2	65	2	1	17
HZ24		22.9	24.0	23.6	24.7	24.3	25.5	2	70	2	1	19
HZ27		25.2	26.6	26.2	27.6	27.2	28.6	2	80	2	1	21
HZ30		28.2	29.6	29.2	30.6	30.2	31.6	2	100	2	1	23
HZ33		31.2	32.6	32.2	33.6	33.2	34.6	2	120	2	1	25
HZ36		34.2	35.7	35.3	36.8	36.4	38.0	2	140	2	1	27

Note : The lower voltage types (HZ2 - HZ12) are available in 3 grades, "A" to "C", each with suffix "-1", "-2" or "-3"

For example the type with $V_Z = 8.5 - 8.9V$ is HZ9B-2

The higher voltage types are only available with suffix "-1", "-2" or "-3" (no grade) e.g. HZ36-3



Zener Diodes 0.5 W

Type No.	Marking	Zener Voltage ⁽²⁾			Test Current	Dynamic Impedance ⁽³⁾		Max. Reverse Leakage Current		Temp. Coefficient of Zener Voltage	
		$V_Z @ I_{ZT}$ (V)			I_{ZT}	$Z_{ZT} @ I_{ZT}$		$I_R @ V_R$		TK_{VZ} (%/K)	
		Min.	Nom.	Max.	(mA)	(Ω)	(mA)	(μ A)	(V)	Min.	Max.

MM1Z2V4 Series, 0.5 W, Case Type : SOD-123



MM1Z2V4	4C	2.28	2.4	2.56	5	100	5	120	1.0	-0.09	-0.06
MM1Z2V7	4D	2.5	2.7	2.9	5	110	5	120	1.0	-0.09	-0.06
MM1Z3V0	4E	2.8	3.0	3.2	5	120	5	50	1.0	-0.08	-0.05
MM1Z3V3	4F	3.1	3.3	3.5	5	130	5	20	1.0	-0.08	-0.05
MM1Z3V6	4H	3.4	3.6	3.8	5	130	5	10	1.0	-0.08	-0.05
MM1Z3V9	4J	3.7	3.9	4.1	5	130	5	5.0	1.0	-0.08	-0.05
MM1Z4V3	4K	4.0	4.3	4.6	5	130	5	5.0	1.0	-0.06	-0.03
MM1Z4V7	4M	4.4	4.7	5.0	5	130	5	2.0	1.0	-0.05	+0.02
MM1Z5V1	4N	4.8	5.1	5.4	5	130	5	2.0	1.5	-0.02	+0.02
MM1Z5V6	4P	5.2	5.6	6.0	5	80	5	1.0	2.5	-0.05	+0.05
MM1Z6V2	4R	5.8	6.2	6.6	5	50	5	1.0	3.0	0.03	0.06
MM1Z6V8	4X	6.4	6.8	7.2	5	30	5	0.5	3.5	0.03	0.07
MM1Z7V5	4Y	7.0	7.5	7.9	5	30	5	0.5	4.0	0.03	0.07
MM1Z8V2	4Z	7.7	8.2	8.7	5	30	5	0.5	5.0	0.03	0.08
MM1Z9V1	5A	8.5	9.1	9.6	5	30	5	0.5	6.0	0.03	0.09
MM1Z10	5B	9.4	10	10.6	5	30	5	0.1	7.0	0.03	0.1
MM1Z11	5C	10.4	11	11.6	5	30	5	0.1	8.0	0.03	0.11
MM1Z12	5D	11.4	12	12.7	5	35	5	0.1	9.0	0.03	0.11
MM1Z13	5E	12.4	13	14.1	5	35	5	0.1	10	0.03	0.11
MM1Z15	5F	13.8	15	15.6	5	40	5	0.1	11	0.03	0.11
MM1Z16	5H	15.3	16	17.1	5	40	5	0.1	12	0.03	0.11
MM1Z18	5J	16.8	18	19.1	5	45	5	0.1	13	0.03	0.11
MM1Z20	5K	18.8	20	21.2	5	50	5	0.1	15	0.03	0.11
MM1Z22	5M	20.8	22	23.3	5	55	5	0.1	17	0.04	0.12
MM1Z24	5N	22.8	24	25.6	5	60	5	0.1	19	0.04	0.12
MM1Z27	5P	25.1	27	28.9	5	70	2	0.1	21	0.04	0.12
MM1Z30	5R	28.0	30	32.0	5	80	2	0.1	23	0.04	0.12
MM1Z33	5X	31.0	33	35.0	5	80	2	0.1	25	0.04	0.12
MM1Z36	5Y	34.0	36	38.0	5	90	2	0.1	27	0.04	0.12
MM1Z39	5Z	37.0	39	41.0	2.5	100	2	2.0	30	0.04	0.12
MM1Z43	6A	40.0	43	46.0	2.5	130	2	2.0	33	0.04	0.12
MM1Z47	6B	44.0	47	50.0	2.5	150	2	2.0	36	0.04	0.12
MM1Z51	6C	48.0	51	54.0	2.5	180	2	1.0	39	0.04	0.12
MM1Z56	6D	52.0	56	60.0	2.5	180	2	1.0	43	0.04	0.12
MM1Z62	6E	58.0	62	66.0	2.5	200	2	0.2	47	0.04	0.12
MM1Z68	6F	64.0	68	72.0	2.5	250	2	0.2	52	0.04	0.12
MM1Z75	6H	70.0	75	79.0	2.5	300	2	0.2	57	0.04	0.12

Notes :

- (1) The type number shown have a standard tolerance of $\pm 5\%$ on the nominal Zener Voltage.
- (2) V_Z is tested with pulses (20ms).
- (3) V_Z is measured at I_Z by given a very small A.C. current signal.



Zener Diodes 0.5 W

TYPE NO.	Marking	Zener Voltage ⁽¹⁾			Test Current	Dynamic Impedance ⁽²⁾		Max. Reverse Leakage Current		Temp. Coefficient of Zener Voltage	
		V _Z @ I _{ZT} (V)			I _{ZT}	Z _{ZT} @ I _{ZT}		I _R @ V _R		TK _{VZ} (%/K)	
		Min.	Nom.	Max.	(mA)	(Ω)	(mA)	(μA)	(V)	Min.	Max.

MM1Z2V0B Series, 0.5 W, Case Type : SOD-123



MM1Z2V0B	9A	1.85	2.0	2.20	5	100	5	120	0.5	-0.09	-0.06
MM1Z2V2B	9B	2.10	2.2	2.40	5	100	5	120	0.7	-0.09	-0.06
MM1Z2V4B	9C	2.30	2.4	2.65	5	100	5	120	1.0	-0.09	-0.06
MM1Z2V7B	9D	2.65	2.7	2.95	5	110	5	120	1.0	-0.09	-0.06
MM1Z3V0B	9E	2.95	3.0	3.25	5	120	5	50	1.0	-0.08	-0.05
MM1Z3V3B	9F	3.25	3.3	3.55	5	130	5	20	1.0	-0.08	-0.05
MM1Z3V6B	9H	3.60	3.6	3.845	5	130	5	10	1.0	-0.08	-0.05
MM1Z3V9B	9J	3.89	3.9	4.16	5	130	5	5	1.0	-0.08	-0.05
MM1Z4V3B	9K	4.17	4.3	4.43	5	130	5	5	1.0	-0.06	-0.03
MM1Z4V7B	9M	4.55	4.7	4.80	5	130	5	2	1.0	-0.05	+0.02
MM1Z5V1B	9N	4.95	5.1	5.20	5	130	5	2	1.5	-0.02	+0.02
MM1Z5V6B	9P	5.45	5.6	5.73	5	80	5	1	2.5	-0.05	+0.05
MM1Z6V2B	9R	6.00	6.2	6.33	5	50	5	1	3.0	0.03	0.06
MM1Z6V8B	9X	6.65	6.8	7.00	5	30	5	0.5	3.5	0.03	0.07
MM1Z7V5B	9Y	7.28	7.5	7.70	5	30	5	0.5	4.0	0.03	0.07
MM1Z8V2B	9Z	8.02	8.2	8.45	5	30	5	0.5	5.0	0.03	0.08
MM1Z9V1B	0A	8.80	9.1	9.30	5	30	5	0.5	6.0	0.03	0.09
MM1Z10B	0B	9.75	10	10.30	5	30	5	0.1	7.0	0.03	0.10
MM1Z11B	0C	10.70	11	11.28	5	30	5	0.1	8.0	0.03	0.11
MM1Z12B	0D	11.70	12	12.30	5	35	5	0.1	9.0	0.03	0.11
MM1Z13B	0E	12.43	13	14.00	5	35	5	0.1	10	0.03	0.11
MM1Z15B	0F	13.80	15	15.56	5	40	5	0.1	11	0.03	0.11
MM1Z16B	0H	15.31	16	17.14	5	40	5	0.1	12	0.03	0.11
MM1Z18B	0J	16.89	18	19.08	5	45	5	0.1	13	0.03	0.11
MM1Z20B	0K	18.80	20	21.14	5	50	5	0.1	15	0.03	0.11
MM1Z22B	0M	20.81	22	23.25	5	55	5	0.1	17	0.04	0.12
MM1Z24B	0N	22.86	24	25.66	5	60	5	0.1	19	0.04	0.12
MM1Z27B	0P	25.10	27	28.90	5	70	2	0.1	21	0.04	0.12
MM1Z30B	0R	28.00	30	32.00	5	80	2	0.1	23	0.04	0.12
MM1Z33B	0X	31.00	33	35.00	5	80	2	0.1	25	0.04	0.12
MM1Z36B	0Y	34.00	36	38.00	5	90	2	0.1	27	0.04	0.12
MM1Z39B	0Z	37.00	39	41.00	5	100	2	2.0	30	0.04	0.12

Notes :

(1) V_Z is tested with pulses (20ms).

(2) V_Z is measured at I_Z by given a very small A.C. current signal.



Zener Diodes 0.5 W

Type No.	Marking	Zener Voltage ^(1,2)			Test Current	Maximum Reverse Leakage Current	
		V _Z @ I _{ZT} (V)				I _{ZT}	I _R @ V _R
		Min.	Nom.	Max.	(μA)	(μA)	(V)

MM1Z4678 Series, 0.5 W, Case Type : SOD-123



MM1Z4678	BC	1.71	1.8	1.89	50	7.5	1.0
MM1Z4679	BD	1.90	2.0	2.10	50	5.0	1.0
MM1Z4680	BE	2.09	2.2	2.31	50	4.0	1.0
MM1Z4681	BF	2.28	2.4	2.52	50	2.0	1.0
MM1Z4682	BH	2.565	2.7	2.835	50	1.0	1.0
MM1Z4683	BJ	2.85	3.0	3.15	50	0.8	1.0
MM1Z4684	BK	3.13	3.3	3.47	50	7.5	1.5
MM1Z4685	BM	3.42	3.6	3.78	50	7.5	2.0
MM1Z4686	BN	3.70	3.9	4.10	50	5.0	2.0
MM1Z4687	BP	4.09	4.3	4.52	50	4.0	2.0
MM1Z4688	BR	4.47	4.7	4.94	50	10	3.0
MM1Z4689	BX	4.85	5.1	5.36	50	10	3.0
MM1Z4690	BY	5.32	5.6	5.88	50	10	4.0
MM1Z4691	BZ	5.89	6.2	6.51	50	10	5.0
MM1Z4692	CA	6.46	6.8	7.14	50	10	5.1
MM1Z4693	CB	7.13	7.5	7.88	50	10	5.7
MM1Z4694	CC	7.79	8.2	8.61	50	1.0	6.2
MM1Z4695	CD	8.27	8.7	9.14	50	1.0	6.6
MM1Z4696	CE	8.65	9.1	9.56	50	1.0	6.9
MM1Z4697	CF	9.50	10	10.50	50	1.0	7.6
MM1Z4698	CH	10.45	11	11.50	50	0.05	8.4
MM1Z4699	CJ	11.40	12	12.60	50	0.05	9.1
MM1Z4700	CK	12.35	13	13.65	50	0.05	9.8
MM1Z4701	CM	13.30	14	14.70	50	0.05	10.6
MM1Z4702	CN	14.25	15	15.75	50	0.05	11.4
MM1Z4703	CP	15.20	16	16.80	50	0.05	12.1
MM1Z4704	CR	16.15	17	17.85	50	0.05	12.9
MM1Z4705	CX	17.10	18	18.90	50	0.05	13.6
MM1Z4706	CY	18.05	19	19.95	50	0.05	14.4
MM1Z4707	CZ	19.00	20	21.00	50	0.01	15.2
MM1Z4708	DA	20.90	22	23.10	50	0.01	16.7
MM1Z4709	DB	22.80	24	25.20	50	0.01	18.2
MM1Z4710	DC	23.75	25	26.25	50	0.01	19.0
MM1Z4711	DD	25.65	27	28.35	50	0.01	20.4
MM1Z4712	DE	26.60	28	29.40	50	0.01	21.2
MM1Z4713	DF	28.50	30	31.50	50	0.01	22.8
MM1Z4714	DH	31.35	33	34.65	50	0.01	25.0
MM1Z4715	DJ	34.20	36	37.80	50	0.01	27.3
MM1Z4716	DK	37.05	39	40.95	50	0.01	29.6
MM1Z4717	DM	40.85	43	45.15	50	0.01	32.6

Notes :

(1) Tested with pulses $t_p = 20$ ms

(2) Nominal Zener voltage is measured with the device junction in thermal equilibrium at $T_L = 30^\circ\text{C} \pm 1^\circ\text{C}$



Zener Diodes 0.5 W

Type No.	Marking	Zener Voltage			Test	Maximum Zener		Test	Maximum Reverse	
		$V_Z @ I_{ZT}$ (V)			Current	Impedance		Current	Leakage Current	
		Min.	Nom.	Max.	I_{ZT} (mA)	$Z_{ZT} @ I_{ZT}$ (Ω)	$Z_{ZK} @ I_{ZK}$ (Ω)	I_{ZK} (mA)	$I_R @ V_R$ (μ A)	V_R (V)

MMSZ5221B Series, 0.5 W, Case Type : SOD-123



MMSZ5221B	A4	2.28	2.4	2.52	20	30	1200	0.25	100	1.0
MMSZ5222B	AB	2.38	2.5	2.63	20	30	1250	0.25	100	1.0
MMSZ5223B	B4	2.57	2.7	2.84	20	30	1300	0.25	75	1.0
MMSZ5224B	AC	2.66	2.8	2.94	20	30	1400	0.25	75	1.0
MMSZ5225B	C4	2.85	3.0	3.15	20	29	1600	0.25	50	1.0
MMSZ5226B	D4	3.14	3.3	3.47	20	28	1600	0.25	25	1.0
MMSZ5227B	E4	3.42	3.6	3.78	20	24	1700	0.25	15	1.0
MMSZ5228B	F4	3.71	3.9	4.10	20	23	1900	0.25	10	1.0
MMSZ5229B	H4	4.09	4.3	4.52	20	22	2000	0.25	5	1.0
MMSZ5230B	J4	4.47	4.7	4.94	20	19	1900	0.25	5	2.0
MMSZ5231B	K4	4.85	5.1	5.36	20	17	1600	0.25	5	2.0
MMSZ5232B	M4	5.32	5.6	5.88	20	11	1600	0.25	5	3.0
MMSZ5233B	AD	5.70	6.0	6.30	20	7	1600	0.25	5	3.5
MMSZ5234B	N4	5.89	6.2	6.51	20	7	1000	0.25	5	4.0
MMSZ5235B	P4	6.46	6.8	7.14	20	5	750	0.25	3	5.0
MMSZ5236B	R4	7.13	7.5	7.88	20	6	500	0.25	3	6.0
MMSZ5237B	X4	7.79	8.2	8.61	20	8	500	0.25	3	6.5
MMSZ5238B	AE	8.27	8.7	9.14	20	8	600	0.25	3	6.5
MMSZ5239B	Y4	8.65	9.1	9.56	20	10	600	0.25	3	7.0
MMSZ5240B	Z4	9.50	10	10.50	20	17	600	0.25	3	8.0
MMSZ5241B	A5	10.45	11	11.50	20	22	600	0.25	2	8.4
MMSZ5242B	B5	11.40	12	12.60	20	30	600	0.25	1	9.1
MMSZ5243B	C5	12.35	13	13.65	9.5	13	600	0.25	0.5	9.9
MMSZ5244B	AF	13.30	14	14.70	9.0	15	600	0.25	0.1	10
MMSZ5245B	D5	14.25	15	15.75	8.5	16	600	0.25	0.1	11
MMSZ5246B	E5	15.20	16	16.80	7.8	17	600	0.25	0.1	12
MMSZ5247B	AH	16.15	17	17.85	7.4	19	600	0.25	0.1	13
MMSZ5248B	F5	17.10	18	18.90	7.0	21	600	0.25	0.1	14
MMSZ5249B	K9	18.05	19	19.95	6.6	23	600	0.25	0.1	14
MMSZ5250B	H5	19.00	20	21.00	6.2	25	600	0.25	0.1	15
MMSZ5251B	J5	20.90	22	23.10	5.6	29	600	0.25	0.1	17
MMSZ5252B	K5	22.80	24	25.20	5.2	33	600	0.25	0.1	18
MMSZ5253B	M9	23.75	25	26.25	5.0	35	600	0.25	0.1	19
MMSZ5254B	M5	25.65	27	28.35	4.6	41	600	0.25	0.1	21
MMSZ5255B	AJ	26.60	28	29.40	4.5	44	600	0.25	0.1	21
MMSZ5256B	N5	28.50	30	31.50	4.2	49	600	0.25	0.1	23
MMSZ5257B	P5	31.35	33	34.65	3.8	58	700	0.25	0.1	25
MMSZ5258B	R5	34.20	36	37.80	3.4	70	700	0.25	0.1	27
MMSZ5259B	X5	37.05	39	40.95	3.2	80	800	0.25	0.1	30
MMSZ5260B	Y5	40.85	43	45.15	3.0	93	900	0.25	0.1	33
MMSZ5261B	Z5	44.65	47	49.35	2.7	105	1000	0.25	0.1	36
MMSZ5262B	A6	48.45	51	53.55	2.5	125	1100	0.25	0.1	39
MMSZ5263B	B6	53.20	56	58.80	2.2	150	1300	0.25	0.1	43
MMSZ5264B	AK	57.00	60	63.00	2.1	170	1400	0.25	0.1	46
MMSZ5265B	C6	58.90	62	65.10	2.0	185	1400	0.25	0.1	47
MMSZ5266B	D6	64.60	68	71.40	1.8	230	1600	0.25	0.1	52
MMSZ5267B	E6	71.25	75	78.75	1.7	270	1700	0.25	0.1	56
MMSZ5268B	F6	77.90	82	86.10	1.5	330	2000	0.25	0.1	62



Zener Diodes 0.5 W

Type No.	Zener Voltage $V_Z @ I_{ZT}^{(1)}$									Test Current	Maximum Zener Impedance			Maximum Reverse Current		
	Suffix A ⁽²⁾			Suffix B ⁽²⁾			Suffix C ⁽²⁾				I_{ZT}	$Z_{ZT} @ I_{ZT}$	$Z_{ZK} @ I_{ZK}$	I_{ZK}	$I_R @ V_R$	
	Min.	Nom.	Max.	Min.	Nom.	Max.	Min.	Nom.	Max.							(V)
Axial Lead	SMD	(V)	(V)	(V)	(V)	(V)	(V)	(V)	(V)	(V)	(mA)	(Ω)	(Ω)	(mA)	(μ A)	(V)

MTZJ / MMZJ Series, Case Type : DO-34 / MiniMELF



MTZJ2.0	MMZJ2.0	1.89	2.00	2.11	2.02	2.11	2.20	-	-	-	5	100	1000	0.5	120	0.5
MTZJ2.2	MMZJ2.2	2.11	2.20	2.29	2.22	2.32	2.42	-	-	-	5	100	1000	0.5	120	0.7
MTZJ2.4	MMZJ2.4	2.34	2.44	2.54	2.43	2.53	2.63	-	-	-	5	100	1000	0.5	120	1.0
MTZJ2.7	MMZJ2.7	2.54	2.65	2.76	2.69	2.8	2.91	-	-	-	5	100	1000	0.5	100	1.0
MTZJ3.0	MMZJ3.0	2.85	2.96	3.07	3.01	3.12	3.23	-	-	-	5	120	1000	0.5	50	1.0
MTZJ3.3	MMZJ3.3	3.16	3.27	3.38	3.32	3.43	3.54	-	-	-	5	120	1000	0.5	20	1.0
MTZJ3.6	MMZJ3.6	3.45	3.58	3.70	3.60	3.72	3.845	-	-	-	5	100	1000	1.0	10	1.0
MTZJ3.9	MMZJ3.9	3.74	3.88	4.01	3.89	4.03	4.16	-	-	-	5	100	1000	1.0	5	1.0
MTZJ4.3	MMZJ4.3	4.04	4.17	4.29	4.17	4.30	4.43	-	-	-	5	100	1000	1.0	5	1.0
MTZJ4.7	MMZJ4.7	4.44	4.56	4.67	4.55	4.68	4.80	-	-	-	5	80	900	0.5	5	1.0
MTZJ5.1	MMZJ5.1	4.81	4.94	5.06	4.94	5.07	5.20	5.08	5.23	5.37	5	70	1200	1.0	5	1.5
MTZJ5.6	MMZJ5.6	5.11	5.42	5.55	5.45	5.59	5.72	5.61	5.76	5.90	5	40	900	1.0	5	2.5
MTZJ6.2	MMZJ6.2	5.78	5.94	6.09	5.96	6.12	6.27	6.12	6.28	6.43	5	30	500	1.0	5	3.0
MTZJ6.8	MMZJ6.8	6.33	6.46	6.62	6.49	6.66	6.82	6.66	6.84	7.01	5	20	150	0.5	2	3.5
MTZJ7.5	MMZJ7.5	6.85	7.04	7.22	7.07	7.26	7.44	7.29	7.48	7.66	5	20	120	0.5	0.5	4.0
MTZJ8.2	MMZJ8.2	7.53	7.73	7.92	7.79	8.00	8.20	8.03	8.24	8.44	5	20	120	0.5	0.5	5.0
MTZJ9.1	MMZJ9.1	8.28	8.51	8.73	8.57	8.79	9.00	8.83	9.07	9.30	5	20	120	0.5	0.5	6.0
MTZJ10	MMZJ10	9.13	9.36	9.59	9.41	9.66	9.90	9.70	9.95	10.19	5	20	120	0.5	0.2	7.0
MTZJ11	MMZJ11	10.14	10.40	10.66	10.53	10.80	11.07	10.82	11.10	11.37	5	20	120	0.5	0.2	8.0
MTZJ12	MMZJ12	11.11	11.40	11.68	11.40	11.70	11.99	11.70	12.00	12.30	5	25	110	0.5	0.2	9.0
MTZJ13	MMZJ13	12.07	12.40	12.72	12.56	12.90	13.23	12.96	13.30	13.63	5	25	110	0.5	0.2	10
MTZJ15	MMZJ15	13.45	13.80	14.14	13.92	14.30	14.67	14.33	14.70	15.06	5	25	110	0.5	0.2	11
MTZJ16	MMZJ16	14.82	15.20	15.58	15.21	15.60	15.99	15.69	16.10	16.50	5	25	150	0.5	0.2	12
MTZJ18	MMZJ18	16.19	16.60	17.02	16.87	17.30	17.73	17.39	17.80	18.21	5	30	150	0.5	0.2	13
MTZJ20	MMZJ20	18.04	18.50	18.96	18.62	19.10	19.58	19.21	19.70	20.19	5	30	200	0.5	0.2	15
MTZJ22	MMZJ22	20.18	20.70	21.22	20.67	21.20	21.73	21.06	21.60	22.14	5	30	200	0.5	0.2	17
MTZJ24	MMZJ24	22.04	22.60	23.17	22.62	23.20	23.78	23.11	23.70	24.29	5	35	200	0.5	0.2	19
MTZJ27	MMZJ27	24.28	24.90	25.52	24.96	25.60	26.24	26.33	27.00	27.68	5	45	250	0.5	0.2	21
MTZJ30	MMZJ30	27.01	27.70	28.39	27.69	28.40	29.11	28.37	29.10	29.83	5	55	250	0.5	0.2	23
MTZJ33	MMZJ33	29.64	30.40	31.16	30.32	31.10	31.88	30.91	31.70	32.49	5	65	250	0.5	0.2	25
MTZJ36	MMZJ36	32.18	33.00	33.83	32.76	33.60	34.44	33.44	34.30	35.16	5	75	250	0.5	0.2	27
MTZJ39	MMZJ39	34.71	35.60	36.49	35.47	36.30	37.13	35.98	36.90	37.82	5	85	250	0.5	0.2	30

Note :

- (1) The Zener voltage is measured 40ms after power is supplied
- (2) When placing an order for an MTZJ or MMZJ type, please add suffix e.g. MTZJ2.0A, MTZJ2.0B.....MMZJ39C



Zener Diodes 0.5 W

Type Number	Zener Voltage $V_Z @ I_{ZT}$				Maximum Zener Impedance			Max. Reverse Leakage Current		Temp. coefficient of Zener Voltage	Admissible Zener Current
	Nom.	Min	Max	I_{ZT}	$Z_{ZT} @ I_{ZT}$	$Z_{ZK} @ I_{ZK}$	I_{ZK}	I_R	at V_R	TK_{VZ}	I_{ZM} (mA)
	(V)	(V)	(V)	(mA)	(Ω)	(Ω)	(mA)	(μ A)	(V)	(% / K)	

MZ55C Series, 0.5 W, Case Type : M1A

MZ55C3V0	3.0	2.8	3.2	5.0	85	600	1.0	4.0	1.0	-0.08...-0.05	125
MZ55C3V3	3.3	3.1	3.5	5.0	85	600	1.0	2.0	1.0	-0.08...-0.05	115
MZ55C3V6	3.6	3.4	3.8	5.0	85	600	1.0	2.0	1.0	-0.08...-0.05	105
MZ55C3V9	3.9	3.7	4.1	5.0	85	600	1.0	2.0	1.0	-0.08...-0.05	95
MZ55C4V3	4.3	4.0	4.6	5.0	75	600	1.0	1.0	1.0	-0.06...-0.03	90
MZ55C4V7	4.7	4.4	5.0	5.0	60	600	1.0	1.0	1.0	-0.05...+0.02	85
MZ55C5V1	5.1	4.8	5.4	5.0	35	550	1.0	1.0	1.0	-0.02...+0.02	80
MZ55C5V6	5.6	5.2	6.0	5.0	25	450	1.0	1.0	1.0	-0.05...+0.05	70
MZ55C6V2	6.2	5.8	6.6	5.0	10	200	1.0	1.0	2.0	0.03...0.06	64
MZ55C6V8	6.8	6.4	7.2	5.0	8	150	1.0	1.0	3.0	0.03...0.07	58
MZ55C7V5	7.5	7.0	7.9	5.0	7	50	1.0	1.0	5.0	0.03...0.07	53
MZ55C8V2	8.2	7.7	8.7	5.0	7	50	1.0	1.0	6.2	0.03...0.08	47
MZ55C9V1	9.1	8.5	9.6	5.0	10	50	1.0	1.0	6.8	0.03...0.09	43
MZ55C10	10	9.4	10.6	5.0	15	70	1.0	1.0	7.5	0.03...0.10	40
MZ55C11	11	10.4	11.6	5.0	20	70	1.0	1.0	8.2	0.03...0.11	36
MZ55C12	12	11.4	12.7	5.0	20	90	1.0	1.0	9.1	0.03...0.11	32
MZ55C13	13	12.4	14.1	5.0	26	110	1.0	1.0	10.0	0.03...0.11	29
MZ55C14	14	13.1	15.0	5.0	28	110	1.0	1.0	10.5	0.03...0.11	28
MZ55C15	15	13.8	15.6	5.0	30	110	1.0	1.0	11	0.03...0.11	27
MZ55C16	16	15.3	17.1	5.0	40	170	1.0	1.0	12	0.03...0.11	24
MZ55C18	18	16.8	19.1	5.0	50	170	1.0	1.0	13	0.03...0.11	21
MZ55C20	20	18.8	21.2	5.0	55	220	1.0	1.0	15	0.03...0.11	20
MZ55C22	22	20.8	23.3	5.0	55	220	1.0	1.0	16	0.04...0.12	18
MZ55C24	24	22.8	25.6	5.0	80	220	1.0	1.0	18	0.04...0.12	16
MZ55C27	27	25.1	28.9	5.0	80	220	1.0	1.0	20	0.04...0.12	14
MZ55C30	30	28	32	5.0	80	220	1.0	1.0	22	0.04...0.12	13
MZ55C33	33	31	35	5.0	80	220	1.0	1.0	24	0.04...0.12	12
MZ55C36	36	34	38	5.0	80	220	1.0	1.0	27	0.04...0.12	11
MZ55C39	39	37	41	2.5	90	500	0.5	1.0	30	0.04...0.12	10
MZ55C43	43	40	46	2.5	90	500	0.5	1.0	33	0.04...0.12	9.2
MZ55C47	47	44	50	2.5	110	600	0.5	1.0	36	0.04...0.12	8.5
MZ55C51	51	48	54	2.5	125	700	0.5	1.0	39	0.04...0.12	7.8
MZ55C56	56	52	60	2.5	135	700	0.5	1.0	43	0.04...0.12	7.0
MZ55C62	62	58	66	2.5	150	1000	0.5	1.0	47	0.04...0.12	6.4
MZ55C68	68	64	72	2.5	200	1000	0.5	1.0	51	0.04...0.12	5.9
MZ55C75	75	70	79	2.5	250	1000	0.5	1.0	56	0.04...0.12	5.3
MZ55C82	82	77	87	2.5	300	1500	0.5	1.0	62	0.05...0.12	4.8
MZ55C91	91	85	96	1.0	450	2000	0.1	1.0	68	0.05...0.12	4.4
MZ55C100	100	94	106	1.0	450	5000	0.1	1.0	75	0.05...0.12	4.0
MZ55C110	110	104	116	1.0	600	5000	0.1	1.0	82	0.05...0.12	3.6
MZ55C120	120	114	127	1.0	800	5500	0.1	1.0	91	0.05...0.12	3.3
MZ55C130	130	124	141	1.0	950	6000	0.1	1.0	100	0.05...0.12	3.1
MZ55C150	150	138	156	1.0	1250	6500	0.1	1.0	110	0.05...0.12	3.7
MZ55C160	160	153	171	1.0	1400	7000	0.1	1.0	120	0.05...0.12	2.5
MZ55C180	180	168	191	1.0	1700	8500	0.1	1.0	130	0.05...0.12	2.2
MZ55C190	190	180	199	1.0	1850	9500	0.1	1.0	140	0.05...0.12	2.1
MZ55C200	200	188	212	1.0	2000	10000	0.1	1.0	150	0.05...0.12	2.0

Note :

- (1) The type number listed have a standard tolerance on the nominal zener voltage of $\pm 5.0\%$.
For $\pm 2\%$ tolerance altered the fifth letter of type from "C" to be "B"



Zener Diodes 0.5 W

Type No.	Suffix ⁽²⁾	Zener Voltage ⁽¹⁾			Dynamic Impedance		Knee Dynamic Impedance		Reverse Current		Zener Voltage Temperature	
		V _Z (V)			Z _Z (Ω)		Z _{ZK} (Ω)		I _R (μA)		γ _Z (mV/°C)	
		Min.	Max.	I _Z (mA)	Max.	I _Z (mA)	Max.	I _Z (mA)	Max.	V _R (V)	Max.	I _Z (mA)

RD2.0E Series, 0.5 W, Case Type : DO-35



RD2.0E	B	1.88	2.20	20	140	20	2000	1.0	120	0.5	-1.0	20
	B1	1.88	2.10									
	B2	2.02	2.20									
RD2.2E	B	2.12	2.41	20	120	20	2000	1.0	120	0.7	-1.5	20
	B1	2.12	2.3									
	B2	2.22	2.41									
RD2.4E	B	2.33	2.63	20	100	20	2000	1.0	120	1.0	-1.5	20
	B1	2.33	2.52									
	B2	2.43	2.63									
RD2.7E	B	2.54	2.91	20	100	20	1000	1.0	100	1.0	-1.5	20
	B1	2.54	2.75									
	B2	2.69	2.91									
RD3.0E	B	2.85	3.22	20	80	20	1000	1.0	50	1.0	-2.0	20
	B1	2.85	3.07									
	B2	3.01	3.22									
RD3.3E	B	3.16	3.53	20	70	20	1000	1.0	20	1.0	-2.0	20
	B1	3.16	3.38									
	B2	3.32	3.53									
RD3.6E	B	3.47	3.83	20	60	20	1000	1.0	10	1.0	-2.0	20
	B1	3.47	3.68									
	B2	3.62	3.83									
RD3.9E	B	3.77	4.14	20	50	20	1000	1.0	5.0	1.0	-2.0	20
	B1	3.77	3.98									
	B2	3.92	4.14									
RD4.3E	B	4.05	4.53	20	40	20	1000	1.0	5.0	1.0	-1.5	20
	B1	4.05	4.26									
	B2	4.20	4.40									
	B3	4.34	4.53									
RD4.7E	B	4.47	4.91	20	25	20	900	1.0	5.0	1.0	-1.5	20
	B1	4.47	4.65									
	B2	4.59	4.77									
	B3	4.71	4.91									
RD5.1E	B	4.85	5.35	20	20	20	800	1.0	5.0	1.5	0.5	20
	B1	4.85	5.03									
	B2	4.97	5.18									
	B3	5.12	5.35									
RD5.6E	B	5.29	5.88	20	13	20	500	1.0	5.0	2.5	1.5	20
	B1	5.29	5.52									
	B2	5.46	5.70									
	B3	5.64	5.88									
RD6.2E	B	5.81	6.40	20	10	20	300	1.0	5.0	3.0	2.0	20
	B1	5.81	6.06									
	B2	5.99	6.24									
	B3	6.16	6.40									



Zener Diodes 0.5 W

Type No.	Suffix ⁽²⁾	Zener Voltage ⁽¹⁾			Dynamic Impedance		Knee Dynamic Impedance		Reverse Current		Zener Voltage Temperature	
		V _Z (V)			Z _Z (Ω)		Z _{ZK} (Ω)		I _R (μA)		γ _Z (mV/°C)	
		Min.	Max.	I _Z (mA)	Max.	I _Z (mA)	Max.	I _Z (mA)	Max.	V _R (V)	Max.	I _Z (mA)

RD2.0E Series, 0.5 W, Case Type : DO-35



RD6.8E	B	6.32	6.97	20	8	20	150	0.5	2.0	3.5	2.5	20
	B1	6.32	6.59									
	B2	6.52	6.79									
	B3	6.70	6.97									
RD7.5E	B	6.88	7.64	20	8	20	120	0.5	0.5	4.0	3.0	20
	B1	6.88	7.19									
	B2	7.11	7.41									
	B3	7.33	7.64									
RD8.2E	B	7.56	8.41	20	8	20	120	0.5	0.5	5.0	4.0	20
	B1	7.56	7.90									
	B2	7.82	8.15									
	B3	8.07	8.41									
RD9.1E	B	8.33	9.29	20	8	20	120	0.5	0.5	6.0	4.5	20
	B1	8.33	8.70									
	B2	8.61	8.99									
	B3	8.89	9.29									
RD10E	B	9.19	10.30	20	8	20	120	0.5	0.2	7.0	5.5	20
	B1	9.19	9.59									
	B2	9.48	9.90									
	B3	9.82	10.30									
RD11E	B	10.18	11.26	10	10	10	120	0.5	0.2	8.0	6.5	10
	B1	10.18	10.63									
	B2	10.50	10.95									
	B3	10.82	11.26									
RD12E	B	11.13	12.30	10	12	10	110	0.5	0.2	9.0	7.5	10
	B1	11.13	11.63									
	B2	11.50	11.92									
	B3	11.80	12.30									
RD13E	B	12.18	13.62	10	14	10	110	0.5	0.2	10	8.5	10
	B1	12.18	12.71									
	B2	12.59	13.16									
	B3	13.03	13.62									
RD15E	B	13.48	15.02	10	16	10	110	0.5	0.2	11	10	10
	B1	13.48	14.09									
	B2	13.95	14.56									
	B3	14.40	15.02									
RD16E	B	14.87	16.50	10	18	10	150	0.5	0.2	12	11	10
	B1	14.87	15.50									
	B2	13.55	15.93									
	B3	15.79	16.50									
RD18E	B	16.34	18.30	10	23	10	150	0.5	0.2	13	13	10
	B1	16.34	17.06									
	B2	16.90	17.67									
	B3	17.51	18.30									

Zener Diodes 0.5 W

Type No.	Suffix ⁽²⁾	Zener Voltage ⁽¹⁾			Dynamic Impedance		Knee Dynamic Impedance		Reverse Current		Zener Voltage Temperature	
		V _Z (V)			Z _Z (Ω)		Z _{ZK} (Ω)		I _R (μA)		γ _Z (mV/°C)	
		Min.	Max.	I _Z (mA)	Max.	I _Z (mA)	Max.	I _Z (mA)	Max.	V _R (V)	Max.	I _Z (mA)

RD2.0E Series, 0.5 W, Case Type : DO-35



RD20E	B	18.11	20.72	10	28	10	200	0.5	0.2	15	15	10
	B1	18.11	18.92									
	B2	18.73	19.57									
	B3	19.38	20.22									
	B4	19.88	20.72									
RD22E	B	20.23	22.61	5	30	5	200	0.5	0.2	17	17	5.0
	B1	20.23	21.08									
	B2	20.76	21.65									
	B3	21.22	22.09									
	B4	21.68	22.61									
RD24E	B	22.26	24.81	5	35	5	200	0.5	0.2	19	19	5.0
	B1	22.26	23.12									
	B2	22.75	23.75									
	B3	23.29	24.27									
	B4	23.81	24.81									
RD27E	B	24.26	27.64	5	45	5	250	0.5	0.2	21	21	5.0
	B1	24.26	25.52									
	B2	24.97	26.26									
	B3	25.63	26.95									
	B4	26.29	27.64									
RD30E	B	26.99	30.51	5	55	5	250	0.5	0.2	23	24	5.0
	B1	26.99	28.39									
	B2	27.70	29.13									
	B3	28.36	29.82									
	B4	29.02	30.51									
RD33E	B	29.63	33.11	5	65	5	250	0.5	0.2	25	26	5.0
	B1	29.68	31.22									
	B2	30.32	31.88									
	B3	30.90	32.50									
	B4	31.49	33.11									
RD36E	B	32.14	35.77	5	75	5	250	0.5	0.2	27	29	5.0
	B1	32.14	33.79									
	B2	32.79	34.49									
	B3	33.40	35.13									
	B4	34.01	35.77									
RD39E	B	34.68	40.80	5	85	5	250	0.5	0.2	30	32	5.0
	B1	34.68	36.47									
	B2	35.36	37.19									
	B3	36.00	37.85									
	B4	36.63	38.52									

Notes:

- (1) The zener voltage (V_Z) is tested for 40 ms after power is supplied
- (2) When placing an order for an RD2.0E type, please add suffix e.g. RD2.0EB, RD2.0EB1 RD39EB4
The B grade is a wide specification, covering full voltage range for suffix "B1" to "B4"



Zener Diodes 0.5 W

Type No.	Zener Voltage $V_Z @ I_{ZT}^{(1)}$		Test Current	Maximum Zener Impedance			Maximum Reverse Current At V_R	
	Min.	Max.		$Z_{ZT} @ I_{ZT}$	$Z_{ZK} @ I_{ZK}$	I_{ZK}	I_R	V_R
	(V)	(V)	(mA)	(Ω)	(Ω)	(mA)	(μ A)	(V)

RLZ Series, Case Type : MiniMELF



RLZ3.6B	3.60	3.85	20	60	1000	1.0	10	1.0
RLZ3.9B	3.89	4.16	20	50	1000	1.0	5	1.0
RLZ4.3B	4.17	4.43	20	40	1000	1.0	5	1.0
RLZ4.7B	4.55	4.80	20	25	900	1.0	5	1.0
RLZ5.1B	4.94	5.20	20	20	800	1.0	5	1.5
RLZ5.6B	5.45	5.73	20	13	500	1.0	5	2.5
RLZ6.2B	5.96	6.27	20	10	300	1.0	5	3.0
RLZ6.8B	6.49	6.83	20	8	150	0.5	2	3.5
RLZ7.5B	7.07	7.45	20	8	120	0.5	0.5	4.0
RLZ8.2B	7.78	8.19	20	8	120	0.5	0.5	5.0
RLZ9.1B	8.57	9.01	20	8	120	0.5	0.5	6.0
RLZ10B	9.41	9.90	20	8	120	0.5	0.2	7.0
RLZ11B	10.50	11.05	10	10	120	0.5	0.2	8.0
RLZ12B	11.44	12.03	10	12	110	0.5	0.2	9.0
RLZ13B	12.55	13.21	10	14	110	0.5	0.2	10
RLZ15B	13.89	14.62	10	16	110	0.5	0.2	11
RLZ16B	15.25	16.04	10	18	150	0.5	0.2	12
RLZ18B	16.82	17.70	10	23	150	0.5	0.2	13
RLZ20B	18.63	19.59	10	28	200	0.5	0.2	15
RLZ22B	20.64	21.71	5	30	200	0.5	0.2	17
RLZ24B	22.61	23.77	5	35	200	0.5	0.2	19
RLZ27B	24.97	26.26	5	45	250	0.5	0.2	21
RLZ30B	27.70	29.13	5	55	250	0.5	0.2	23
RLZ33B	30.32	31.88	5	65	250	0.5	0.2	25
RLZ36B	32.79	34.49	5	75	250	0.5	0.2	27
RLZ39B	35.36	37.19	5	85	250	0.5	0.2	30

Note :

(1) The Zener voltage is measured 40ms after power is supplied



Zener Diodes 0.5 W

Type	Zener Voltage $V_Z @ I_{ZT}$			Maximum Zener Impedance			Maximum Reverse Leakage Current			Temp. coefficient of Zener Voltage $\alpha_{vz}(\% / K)$
	Nom	I_{ZT}	V_{ZT}	$Z_{ZT} @ I_{ZT}$	$Z_{Zk} @ I_{Zk}$	I_{Zk}	I_R	$I_R^{(2)}$	at V_R	
	(V)	(mA)	(V) ⁽¹⁾	(Ω)	(Ω)	(mA)	(μA)	(μA)	(V)	

TZMC Series, 0.5 W, Case Type : MiniMELF



TZMC2V4	2.4	5	2.28 to 2.56	< 85	< 600	1	< 50	< 100	1	-0.09...-0.06
TZMC2V7	2.7	5	2.5 to 2.9	< 85	< 600	1	< 10	< 50	1	-0.09...-0.06
TZMC3V0	3.0	5	2.8 to 3.2	< 90	< 600	1	< 4	< 40	1	-0.08...-0.05
TZMC3V3	3.3	5	3.1 to 3.5	< 90	< 600	1	< 2	< 40	1	-0.08...-0.05
TZMC3V6	3.6	5	3.4 to 3.8	< 90	< 600	1	< 2	< 40	1	-0.08...-0.05
TZMC3V9	3.9	5	3.7 to 4.1	< 90	< 600	1	< 2	< 40	1	-0.08...-0.05
TZMC4V3	4.3	5	4.0 to 4.6	< 90	< 600	1	< 1	< 20	1	-0.06...-0.03
TZMC4V7	4.7	5	4.4 to 5.0	< 80	< 600	1	< 0.5	< 10	1	-0.05...-0.02
TZMC5V1	5.1	5	4.8 to 5.4	< 60	< 550	1	< 0.1	< 2	1	-0.02...+0.02
TZMC5V6	5.6	5	5.2 to 6.0	< 40	< 450	1	< 0.1	< 2	1	-0.05...+0.05
TZMC6V2	6.2	5	5.8 to 6.6	< 10	< 200	1	< 0.1	< 2	2	-0.03...+0.06
TZMC6V8	6.8	5	6.4 to 7.2	< 8	< 150	1	< 0.1	< 2	3	0.03...0.07
TZMC7V5	7.5	5	7.0 to 7.9	< 7	< 50	1	< 0.1	< 2	5	0.03...0.07
TZMC8V2	8.2	5	7.7 to 8.7	< 7	< 50	1	< 0.1	< 2	6.2	0.03...0.08
TZMC9V1	9.1	5	8.5 to 9.6	< 10	< 50	1	< 0.1	< 2	6.8	0.03...0.09
TZMC10	10	5	9.4 to 10.6	< 15	< 70	1	< 0.1	< 2	7.5	0.03...0.10
TZMC11	11	5	10.4 to 11.6	< 20	< 70	1	< 0.1	< 2	8.2	0.03...0.11
TZMC12	12	5	11.4 to 12.7	< 20	< 90	1	< 0.1	< 2	9.1	0.03...0.11
TZMC13	13	5	12.4 to 14.1	< 26	< 110	1	< 0.1	< 2	10	0.03...0.11
TZMC15	15	5	13.8 to 15.6	< 30	< 110	1	< 0.1	< 2	11	0.03...0.11
TZMC16	16	5	15.3 to 17.1	< 40	< 170	1	< 0.1	< 2	12	0.03...0.11
TZMC18	18	5	16.8 to 19.1	< 50	< 170	1	< 0.1	< 2	13	0.03...0.11
TZMC20	20	5	18.8 to 21.2	< 55	< 220	1	< 0.1	< 2	15	0.03...0.11
TZMC22	22	5	20.8 to 23.3	< 55	< 220	1	< 0.1	< 2	16	0.04...0.12
TZMC24	24	5	22.8 to 25.6	< 80	< 220	1	< 0.1	< 2	18	0.04...0.12
TZMC27	27	5	25.1 to 28.9	< 80	< 220	1	< 0.1	< 2	20	0.04...0.12
TZMC30	30	5	28 to 32	< 80	< 220	1	< 0.1	< 2	22	0.04...0.12
TZMC33	33	5	31 to 35	< 80	< 220	1	< 0.1	< 2	24	0.04...0.12
TZMC36	36	5	34 to 38	< 80	< 220	1	< 0.1	< 2	27	0.04...0.12
TZMC39	39	2.5	37 to 41	< 90	< 500	1	< 0.1	< 5	30	0.04...0.12
TZMC43	43	2.5	40 to 46	< 90	< 600	0.5	< 0.1	< 5	33	0.04...0.12
TZMC47	47	2.5	44 to 50	< 110	< 700	0.5	< 0.1	< 5	36	0.04...0.12
TZMC51	51	2.5	48 to 54	< 125	< 700	0.5	< 0.1	< 10	39	0.04...0.12
TZMC56	56	2.5	52 to 60	< 135	< 1000	0.5	< 0.1	< 10	43	0.04...0.12
TZMC62	62	2.5	58 to 66	< 150	< 1000	0.5	< 0.1	< 10	47	0.04...0.12
TZMC68	68	2.5	64 to 72	< 200	< 1000	0.5	< 0.1	< 10	51	0.04...0.12
TZMC75	75	2.5	70 to 79	< 250	< 1500	0.5	< 0.1	< 10	56	0.04...0.12

Notes :

(1) Tighter tolerances are available on request:

TZMA... $\pm 1\%$ of V_{Znom}

TZMB... $\pm 2\%$ of V_{Znom}

TZMF... $\pm 3\%$ of V_{Znom}

(2) At $T_j = 150^\circ C$

Zener Diodes 0.5 W

Type No.	Zener Voltage $V_Z @ I_{ZT}$		Dynamic Resistance		Maximum Reverse Leakage Current		Temp. coefficient of Zener Voltage At I_{ZT}		Admissible Zener Current ⁽²⁾
	Nom ⁽¹⁾	I_{ZT}	at $I_Z = 5\text{mA}$ $f = 1\text{ kHz}$	at $I_Z = 1\text{mA}$ $f = 1\text{ kHz}$	I_R	at V_R	$\alpha_{VZ}(10^{-4} / ^\circ\text{C})$		I_Z
	(V)	(mA)	$r_{zj} (\Omega)$	$r_{zj} (\Omega)$	(μA)	(V)	min.	max.	(mA)

ZMM Series, 0.5 W, Case Type : MiniMELF



ZMM2.4	2.4	5	< 100	< 600	50	0.8	-10	-5	175
ZMM2.7	2.7	5	75 (< 83)	< 500	20	0.8	-9	-4	160
ZMM3.0	3.0	5	80 (< 95)	< 500	10	0.8	-9	-3	140
ZMM3.3	3.3	5	80 (< 95)	< 500	6.0	0.8	-8	-3	130
ZMM3.6	3.6	5	80 (< 95)	< 500	6.0	0.8	-8	-3	120
ZMM3.9	3.9	5	80 (< 95)	< 500	1.6	0.8	-7	-3	110
ZMM4.3	4.3	5	80 (< 95)	< 500	1.0	0.8	-6	-1	100
ZMM4.7	4.7	5	70 (< 78)	< 500	0.1	0.8	-5	+2	90
ZMM5.1	5.1	5	30 (< 60)	< 480	0.1	0.8	-3	+4	80
ZMM5.6	5.6	5	10 (< 40)	< 400	0.1	1	-2	+6	70
ZMM6.2	6.2	5	4.8 (< 10)	< 200	0.1	2	-1	+7	64
ZMM6.8	6.8	5	4.5 (< 8)	< 150	0.1	3	+2	+7	58
ZMM7.5	7.5	5	4 (< 7)	< 50	0.1	5	+3	+7	53
ZMM8.2	8.2	5	4.5 (< 7)	< 50	0.1	6	+4	+7	47
ZMM9.1	9.1	5	4.8 (< 10)	< 50	0.1	7	+5	+8	43
ZMM10	10	5	5.2 (< 15)	< 70	0.1	7.5	+5	+8	40
ZMM11	11	5	6 (< 20)	< 70	0.1	8.5	+5	+9	36
ZMM12	12	5	7 (< 20)	< 90	0.1	9	+6	+9	32
ZMM13	13	5	9 (< 25)	< 110	0.1	10	+7	+9	29
ZMM15	15	5	11 (< 30)	< 110	0.1	11	+7	+9	27
ZMM16	16	5	13 (< 40)	< 170	0.1	12	+8	+9.5	24
ZMM18	18	5	18 (< 50)	< 170	0.1	14	+8	+9.5	21
ZMM20	20	5	20 (< 50)	< 220	0.1	15	+8	+10	20
ZMM22	22	5	25 (< 55)	< 220	0.1	17	+8	+10	18
ZMM24	24	5	28 (< 80)	< 220	0.1	18	+8	+10	16
ZMM27	27	5	30 (< 80)	< 250	0.1	20	+8	+10	14
ZMM30	30	5	35 (< 80)	< 250	0.1	22.5	+8	+10	13
ZMM33	33	5	40 (< 80)	< 250	0.1	25	+8	+10	12
ZMM36	36	5	40 (< 90)	< 250	0.1	27	+8	+10	11
ZMM39	39	5	50 (< 90)	< 300	0.1	29	+10	+12	10
ZMM43	43	5	60 (< 100)	< 700	0.1	32	+10	+12	9.2
ZMM47	47	5	70 (< 100)	< 750	0.1	35	+10	+12	8.5
ZMM51	51	5	70 (< 100)	< 750	0.1	38	+10	+12	7.8
ZMM56	56	2.5	< 135 ⁽³⁾	< 1000 ⁽⁴⁾	0.1	42	+10 (typ.)		7.1
ZMM62	62	2.5	< 150 ⁽³⁾	< 1000 ⁽⁴⁾	0.1	47	+ 10 (typ.)		6.4
ZMM68	68	2.5	< 200 ⁽³⁾	< 1000 ⁽⁴⁾	0.1	51	+ 10 (typ.)		5.8
ZMM75	75	2.5	< 250 ⁽³⁾	< 1500 ⁽⁴⁾	0.1	55	+ 10 (typ.)		5.3

Notes:

- (1) Tested with pulse $t_p = 5\text{ ms}$
- (2) Valid provided that leads are kept at ambient temperature
- (3) At $I_Z = 2.5\text{mA}$
- (4) At $I_Z = 0.5\text{mA}$
- (5) Standard zener voltage tolerance is $\pm 5\%$. Other tolerances are available upon request
- (6) $V_F = 1.25\text{ Vmax. @ } I_F = 200\text{ mA}$



Zener Diodes 0.5 W

Type No.	Nominal Zener Voltage	Test Current	Maximum Zener Impedance			Maximum Reverse Leakage Current		Maximum DC Zener Current	Maximum Surge Current
	$V_Z @ I_{ZT}$	I_{ZT}	$Z_{ZT} @ I_{ZT}$	$Z_{ZK} @ I_{ZK}$	I_{ZK}	$I_R @ V_R$		I_{ZM}	$I_{RM}^{(2)}$
	(V)	(mA)		(Ω)	(mA)	(μ A)	(V)	(mA)	(mApk)

Z043 Series, 0.5 W, Case Type : DO-41



Z043	43	2.75	70	1500	0.25	5.0	32	11.0	52
Z047	47	2.40	80	1500	0.25	5.0	35	9.6	47
Z051	51	2.23	95	1500	0.25	5.0	38	8.9	44
Z056	56	2.00	110	2000	0.25	5.0	42	8.0	40
Z062	62	1.83	125	2000	0.25	5.0	47	7.3	36
Z068	68	1.65	150	2000	0.25	5.0	52	6.6	33
Z075	75	1.50	175	2000	0.25	5.0	57	6.0	30
Z082	82	1.37	200	3000	0.25	5.0	62	5.5	27
Z091	91	1.25	250	3000	0.25	5.0	73	5.0	24
Z0100	100	1.12	350	3000	0.25	5.0	76	4.5	22
Z0110	110	1.00	450	4000	0.25	5.0	83	4.1	20
Z0120	120	0.95	550	4500	0.25	5.0	91	3.8	18
Z0130	130	0.88	700	5000	0.25	5.0	98	3.5	17
Z0150	150	0.75	1000	6000	0.25	5.0	114	3.0	15
Z0160	160	0.70	1100	6500	0.25	5.0	121	2.8	14
Z0180	180	0.62	1400	7000	0.25	5.0	136	2.5	12.5
Z0190	190	0.57	1400	7500	0.25	5.0	144	2.3	11.8
Z0200	200	0.55	1700	8000	0.25	5.0	152	2.2	11.2

Note :

- (1) The type numbers listed have a standard tolerance on the nominal zener voltage of $\pm 10\%$
Add suffix "A" for $\pm 5\%$ tolerance, add suffix "B" for $\pm 2\%$ tolerance
- (2) Surge current is a non-repetitive 8.3ms square pulse width wave or equivalent sine-wave superimposed on I_{ZT} as per JEDEC method

Zener Diodes 0.5 W

Type No.	Zener Voltage		Dynamic Resistance		Reverse Voltage at $I_R = 100 \text{ nA}$	Temp. coefficient of Zener Voltage At I_{ZT}		Admissible Zener Current ⁽²⁾ I_Z (mA)
	$V_Z @ I_{ZT}$		at $I_Z = 5 \text{ mA}$ $f = 1 \text{ kHz}$	at $I_Z = 1 \text{ mA}$ $f = 1 \text{ kHz}$		$\alpha_{VZ}(10^{-4} / ^\circ\text{C})$		
	Nom ⁽¹⁾	I_{ZT}			min.	max.		
	(V)	(mA)	$r_{zj} (\Omega)$	$r_{zj} (\Omega)$				

ZPD Series, 0.5 W, Case Type : DO-35



ZPD2.7	2.7	5	6.5 (<8)	< 500	-	-9	-4	160
ZPD3.0	3.0	5	75 (<83)	< 500	-	-9	-3	140
ZPD3.3	3.3	5	80 (<95)	< 500	-	-8	-3	130
ZPD3.6	3.6	5	80 (<95)	< 500	-	-8	-3	120
ZPD3.9	3.9	5	80 (<95)	< 500	-	-7	-3	110
ZPD4.3	4.3	5	80 (<95)	< 500	-	-6	-1	100
ZPD4.7	4.7	5	70 (<78)	< 500	-	-5	+2	90
ZPD5.1	5.1	5	30 (<60)	< 480	> 0.8	-3	+4	80
ZPD5.6	5.6	5	10 (<40)	< 400	> 1	-2	+6	70
ZPD6.2	6.2	5	4.8 (<10)	< 200	> 2	-1	+7	64
ZPD6.8	6.8	5	4.5 (<8)	< 150	> 3	+2	+7	58
ZPD7.5	7.5	5	4.0 (<7)	< 50	> 5	+3	+7	53
ZPD8.2	8.2	5	4.5 (<7)	< 50	> 6	+4	+7	47
ZPD9.1	9.1	5	4.8 (<10)	< 50	> 7	+5	+8	43
ZPD10	10	5	5.2 (<15)	< 70	> 7.5	+5	+8	40
ZPD11	11	5	6 (<20)	< 70	> 8.5	+5	+9	36
ZPD12	12	5	7 (<20)	< 90	> 9	+6	+9	32
ZPD13	13	5	9 (<25)	< 110	> 10	+7	+9	29
ZPD15	15	5	11 (<30)	< 110	> 11	+7	+9	27
ZPD16	16	5	13 (<40)	< 170	> 12	+8	+9.5	24
ZPD18	18	5	18 (<50)	< 170	> 14	+8	+9.5	21
ZPD20	20	5	20 (<50)	< 220	> 15	+8	+10	20
ZPD22	22	5	25 (<55)	< 220	> 17	+8	+10	18
ZPD24	24	5	28 (<80)	< 220	> 18	+8	+10	16
ZPD27	27	5	30 (<80)	< 250	> 20	+8	+10	14
ZPD30	30	5	35 (<80)	< 250	> 22.5	+8	+10	13
ZPD33	33	5	40 (<80)	< 250	> 25	+8	+10	12
ZPD36	36	5	40 (<90)	< 250	> 27	+8	+10	11
ZPD39	39	5	50 (<90)	< 300	> 29	+10	+12	10
ZPD43	43	5	60 (<100)	< 700	> 32	+10	+12	9.2
ZPD47	47	5	70 (<100)	< 750	> 35	+10	+12	8.5
ZPD51	51	5	70 (<100)	< 750	> 38	+10	+12	7.8
ZPD56	56	2.5	<135 ⁽³⁾	< 1000 ⁽⁴⁾	> 42	+10 (typ.)		7.1
ZPD62	62	2.5	<150 ⁽³⁾	< 1000 ⁽⁴⁾	> 47	+10 (typ.)		6.4
ZPD68	68	2.5	<200 ⁽³⁾	< 1000 ⁽⁴⁾	> 51	+10 (typ.)		5.8
ZPD75	75	2.5	<250 ⁽³⁾	<1500 ⁽⁴⁾	> 55	+10 (typ.)		5.3

Notes :

- (1) Tested with pulse $t_p = 5 \text{ ms}$
- (2) Valid provided that leads are at distance of 4 mm from case and kept at ambient temperature
- (3) At $I_Z = 2.5 \text{ mA}$
- (4) At $I_Z = 0.5 \text{ mA}$
- (5) The type numbers listed have a standard tolerance on the nominal zener voltage of $\pm 5.0\%$



Zener Diodes 1 W

The plastic material carries U/L recognition 94V-O.

Type No.		Nominal Zener Voltage		Maximum Zener Impedance			Maximum Reverse Leakage Current		Maximum DC Zener Current
		Vz@IzT ⁽²⁾	IzT	ZzT @ IzT	Zzk @ Izk	Izk	IR @ VR	IzM	
Axial Lead	SMD	(V)	(mA)	(Ω)	(Ω)	(mA)	(μA)	(V)	(mA)

1N4728/SZ10 Series, 1 W, Case Type : DO-41/SMA

1N4728	SZ103D	3.3	76.0	10	400	1.0	100	1.0	276
1N4729	SZ103G	3.6	69.0	10	400	1.0	100	1.0	252
1N4730	SZ103J	3.9	64.0	9.0	400	1.0	50	1.0	234
1N4731	SZ104D	4.3	58.0	9.0	400	1.0	10	1.0	217
1N4732	SZ104H	4.7	53.0	8.0	500	1.0	10	1.0	193
1N4733	SZ105B	5.1	49.0	7.0	550	1.0	10	1.0	178
1N4734	SZ105G	5.6	45.0	5.0	600	1.0	10	2.0	162
1N4735	SZ106C	6.2	41.0	2.0	700	1.0	10	3.0	146
1N4736	SZ106I	6.8	37.0	3.5	700	1.0	10	4.0	133
1N4737	SZ107F	7.5	34.0	4.0	700	0.5	10	5.0	121
1N4738	SZ108C	8.2	31.0	4.5	700	0.5	10	6.0	110
1N4739	SZ109B	9.1	28.0	5.0	700	0.5	10	7.0	100
1N4740	SZ1010	10	25.0	7.0	700	0.25	10	7.6	91
1N4741	SZ1011	11	23.0	8.0	700	0.25	5.0	8.4	83
1N4742	SZ1012	12	21.0	9.0	700	0.25	5.0	9.1	76
1N4743	SZ1013	13	19.0	10	700	0.25	5.0	9.9	69
1N4744	SZ1015	15	17.0	14	700	0.25	5.0	11.4	61
1N4745	SZ1016	16	15.5	16	700	0.25	5.0	12.2	57
1N4746	SZ1018	18	14.0	20	750	0.25	5.0	13.7	50
1N4747	SZ1020	20	12.5	22	750	0.25	5.0	15.2	45
1N4748	SZ1022	22	11.5	23	750	0.25	5.0	16.7	41
1N4749	SZ1024	24	10.5	25	750	0.25	5.0	18.2	38
1N4750	SZ1027	27	9.5	35	750	0.25	5.0	20.6	34
1N4751	SZ1030	30	8.5	40	1000	0.25	5.0	22.8	30
1N4752	SZ1033	33	7.5	45	1000	0.25	5.0	25.1	27
1N4753	SZ1036	36	7.0	50	1000	0.25	5.0	27.4	25
1N4754	SZ1039	39	6.5	60	1000	0.25	5.0	29.7	23
1N4755	SZ1043	43	6.0	70	1500	0.25	5.0	32.7	22
1N4756	SZ1047	47	5.5	80	1500	0.25	5.0	35.8	19
1N4757	SZ1051	51	5.0	95	1500	0.25	5.0	38.8	18
1N4758	SZ1056	56	4.5	110	2000	0.25	5.0	42.6	16
1N4759	SZ1062	62	4.0	125	2000	0.25	5.0	47.1	14
1N4760	SZ1068	68	3.7	150	2000	0.25	5.0	51.7	13
1N4761	SZ1075	75	3.3	175	2000	0.25	5.0	56.0	12
1N4762	SZ1082	82	3.0	200	3000	0.25	5.0	62.2	11
1N4763	SZ1091	91	2.8	250	3000	0.25	5.0	69.2	10
1N4764	SZ10B0	100	2.5	350	3000	0.25	5.0	76.0	9.0
Z1110	SZ10B1	110	2.3	450	4000	0.25	5.0	83.6	8.6
Z1120	SZ10B2	120	2.0	550	4500	0.25	5.0	91.2	7.8
Z1130	SZ10B3	130	1.9	700	5000	0.25	5.0	98.8	7.0
Z1150	SZ10B5	150	1.7	1000	6000	0.25	5.0	114.0	6.4
Z1160	SZ10B6	160	1.6	1100	6500	0.25	5.0	121.6	5.8
Z1180	SZ10B8	180	1.4	1200	7000	0.25	5.0	136.8	5.2
Z1200	SZ10D0	200	1.2	1900	9990	0.25	5.0	152.0	4.7
Z1220	SZ10D2	220	1.0	1600	8000	0.25	5.0	167.2	4.0
Z1240	SZ10D4	240	0.93	1800	8500	0.25	5.0	182.4	3.8
Z1250	SZ10D5	250	0.9	2000	9000	0.25	5.0	190	3.6
Z1270	SZ10D7	270	0.82	2100	9000	0.25	5.0	205	3.3
Z1300	SZ10E0	300	0.75	2300	9500	0.25	5.0	228	3.0

Notes :

- (1) For Vz ≤ 200 V; VF = 1.2 Vmax. @ IF = 200 mA and for Vz > 200 V; VF = 2 Vmax. @ IF = 200 mA.
- (2) The type numbers listed have a standard tolerance on the nominal zener voltage of ± 10%. A standard tolerance of ± 5% is also available by adding suffix "A" to the standard type for Axial Lead or by replacing the fourth digit of standard type from "0" to "5" for SMD.
- (3) "SZ" for SMD parts will be omitted on marking of the diode
- (4) Use suffix "C" for tolerance ± 2% (Axial Lead)



Zener Diodes 1 W

Type No.		Nominal Zener Voltage		Maximum Zener Impedance			Maximum Reverse Leakage Current		Maximum DC Zener Current	Maximum Surge Current
		$V_Z^{(1)}$ @ I_{ZT}	I_{ZT}	Z_{ZT} @ I_{ZT}	Z_{ZK} @ I_{ZK}	I_{ZK}	I_R @ V_R	I_{ZM}	I_{RM}	
Axial Lead	SMD	(V)	(mA)	(Ω)	(Ω)	(mA)	(μ A)	(V)	(mA)	(mApk)

MZ4728/SMZ15 Series, 1.0 W, Case Type : M1A/SOD-123FL



MZ4728	SMZ153D	3.3	76.0	10	400	1.0	100	1.0	276	1380
MZ4729	SMZ153G	3.6	69.0	10	400	1.0	100	1.0	252	1260
MZ4730	SMZ153J	3.9	64.0	9.0	400	1.0	50	1.0	234	1190
MZ4731	SMZ154D	4.3	58.0	9.0	400	1.0	10	1.0	217	1070
MZ4732	SMZ154H	4.7	53.0	8.0	500	1.0	10	1.0	193	970
MZ4733	SMZ155B	5.1	49.0	7.0	550	1.0	10	1.0	178	890
MZ4734	SMZ155G	5.6	45.0	5.0	600	1.0	10	2.0	162	810
MZ4735	SMZ156C	6.2	41.0	2.0	700	1.0	10	3.0	146	730
MZ4736	SMZ156I	6.8	37.0	3.5	700	1.0	10	4.0	133	660
MZ4737	SMZ157F	7.5	34.0	4.0	700	0.5	10	5.0	121	605
MZ4738	SMZ158C	8.2	31.0	4.5	700	0.5	10	6.0	110	550
MZ4739	SMZ159B	9.1	28.0	5.0	700	0.5	10	7.0	100	500
MZ4740	SMZ1515	10	25.0	7.0	700	0.25	10	7.6	91	454
MZ4741	SMZ1511	11	23.0	8.0	700	0.25	5.0	8.4	83	414
MZ4742	SMZ1512	12	21.0	9.0	700	0.25	5.0	9.1	76	380
MZ4743	SMZ1513	13	19.0	10	700	0.25	5.0	9.9	69	344
MZ4744	SMZ1515	15	17.0	14	700	0.25	5.0	11.4	61	305
MZ4745	SMZ1516	16	15.5	16	700	0.25	5.0	12.2	57	285
MZ4746	SMZ1518	18	14.0	20	750	0.25	5.0	13.7	50	250
MZ4747	SMZ1520	20	12.5	22	750	0.25	5.0	15.2	45	225
MZ4748	SMZ1522	22	11.5	23	750	0.25	5.0	16.7	41	205
MZ4749	SMZ1524	24	10.5	25	750	0.25	5.0	18.2	38	190
MZ4750	SMZ1527	27	9.5	35	750	0.25	5.0	20.6	34	170
MZ4751	SMZ1530	30	8.5	40	1000	0.25	5.0	22.8	30	150
MZ4752	SMZ1533	33	7.5	45	1000	0.25	5.0	25.1	27	135
MZ4753	SMZ1536	36	7.0	50	1000	0.25	5.0	27.4	25	125
MZ4754	SMZ1539	39	6.5	60	1000	0.25	5.0	29.7	23	115
MZ4755	SMZ1543	43	6.0	70	1500	0.25	5.0	32.7	22	110
MZ4756	SMZ1547	47	5.5	80	1500	0.25	5.0	35.8	19	95
MZ4757	SMZ1551	51	5.0	95	1500	0.25	5.0	38.8	18	90
MZ4758	SMZ1556	56	4.5	110	2000	0.25	5.0	42.6	16	80
MZ4759	SMZ1562	62	4.0	125	2000	0.25	5.0	47.1	14	70
MZ4760	SMZ1568	68	3.7	150	2000	0.25	5.0	51.7	13	65
MZ4761	SMZ1575	75	3.3	175	2000	0.25	5.0	56.0	12	60
MZ4762	SMZ1582	82	3.0	200	3000	0.25	5.0	62.2	11	55
MZ4763	SMZ1591	91	2.8	250	3000	0.25	5.0	69.2	10	50
MZ4764	SMZ15B0	100	2.5	350	3000	0.25	5.0	76.0	9.0	45
MZ1110	SMZ15B1	110	2.3	450	4000	0.25	5.0	83.6	8.6	40
MZ1120	SMZ15B2	120	2.0	550	4500	0.25	5.0	91.2	7.8	37
MZ1130	SMZ15B3	130	1.9	700	5000	0.25	5.0	98.8	7.0	34
MZ1150	SMZ15B5	150	1.7	1000	6000	0.25	5.0	114.0	6.4	30
MZ1160	SMZ15B6	160	1.6	1100	6500	0.25	5.0	121.6	5.8	28
MZ1180	SMZ15B8	180	1.4	1200	7000	0.25	5.0	136.8	5.2	25
MZ1200	SMZ15D0	200	1.2	1900	9990	0.25	5.0	152.0	4.7	22

Note :

(1) The type number listed have a standard tolerance on the nominal zener voltage of $\pm 10\%$. Suffix "A" indicates $\pm 5\%$ tolerance, suffix "C" indicates $\pm 2\%$ tolerance. For SMD package the type number listed have a standard tolerance on the nominal zener voltage of $\pm 5\%$

Zener Diodes 1 W

Type No.		Nominal Zener Voltage ⁽³⁾		Maximum Zener Impedance ⁽¹⁾			Maximum Reverse Leakage Current		Maximum Regulator Current	Maximum Surge Current
		V _Z @ I _{ZT}	I _{ZT}	Z _{ZT} @ I _{ZT}	Z _{ZK} @ I _{ZK}	I _{ZK}	I _R @ V _R	I _{ZM} ⁽²⁾	I _{RM}	
Axial Lead	SMD	(V)	(mA)	(Ω)	(Ω)	(mA)	(μA)	(V)	(mA)	(mA)

1N4728AG/ZM4728A Series, Case Type : DO-41G / MELF



1N4728AG	ZM4728A	3.3	76.0	10	400	1.0	100	1.0	276	1380
1N4729AG	ZM4729A	3.6	69.0	10	400	1.0	100	1.0	252	1260
1N4730AG	ZM4730A	3.9	64.0	9.0	400	1.0	50	1.0	234	1190
1N4731AG	ZM4731A	4.3	58.0	9.0	400	1.0	10	1.0	217	1070
1N4732AG	ZM4732A	4.7	53.0	8.0	500	1.0	10	1.0	193	970
1N4733AG	ZM4733A	5.1	49.0	7.0	550	1.0	10	1.0	178	890
1N4734AG	ZM4734A	5.6	45.0	5.0	600	1.0	10	2.0	162	810
1N4735AG	ZM4735A	6.2	41	2.0	700	1.0	10	3.0	146	730
1N4736AG	ZM4736A	6.8	37.0	3.5	700	1.0	10	4.0	133	660
1N4737AG	ZM4737A	7.5	34.0	4.0	700	0.5	10	5.0	121	605
1N4738AG	ZM4738A	8.2	31	4.5	700	0.5	10	6.0	110	550
1N4739AG	ZM4739A	9.1	28.0	5.0	700	0.5	10	7.0	100	500
1N4740AG	ZM4740A	10	25.0	7.0	700	0.25	10	7.6	91	454
1N4741AG	ZM4741A	11	23.0	8.0	700	0.25	5.0	8.4	83	414
1N4742AG	ZM4742A	12	21	9.0	700	0.25	5.0	9.1	76	380
1N4743AG	ZM4743A	13	19.0	10	700	0.25	5.0	9.9	69	344
1N4744AG	ZM4744A	15	17.0	14	700	0.25	5.0	11.4	61	305
1N4745AG	ZM4745A	16	15.5	16	700	0.25	5.0	12.2	57	285
1N4746AG	ZM4746A	18	14.0	20	750	0.25	5.0	13.7	50	250
1N4747AG	ZM4747A	20	12.5	22	750	0.25	5.0	15.2	45	225
1N4748AG	ZM4748A	22	11.5	23	750	0.25	5.0	16.7	41	205
1N4749AG	ZM4749A	24	10.5	25	750	0.25	5.0	18.2	38	190
1N4750AG	ZM4750A	27	9.5	35	750	0.25	5.0	20.6	34	170
1N4751AG	ZM4751A	30	8.5	40	1000	0.25	5.0	22.8	30	150
1N4752AG	ZM4752A	33	7.5	45	1000	0.25	5.0	25.1	27	135
1N4753AG	ZM4753A	36	7.0	50	1000	0.25	5.0	27.4	25	125
1N4754AG	ZM4754A	39	6.5	60	1000	0.25	5.0	29.7	23	115
1N4755AG	ZM4755A	43	6.0	70	1500	0.25	5.0	32.7	22	110
1N4756AG	ZM4756A	47	5.5	80	1500	0.25	5.0	35.8	19	95
1N4757AG	ZM4757A	51	5.0	95	1500	0.25	5.0	38.8	18	90
1N4758AG	ZM4758A	56	4.5	110	2000	0.25	5.0	42.6	16	80
1N4759AG	ZM4759A	62	4.0	125	2000	0.25	5.0	47.1	14	70
1N4760AG	ZM4760A	68	3.7	150	2000	0.25	5.0	51.7	13	65
1N4761AG	ZM4761A	75	3.3	175	2000	0.25	5.0	56.0	12	60
1N4762AG	ZM4762A	82	3.0	200	3000	0.25	5.0	62.2	11	55
1N4763AG	ZM4763A	91	2.8	250	3000	0.25	5.0	69.2	10	50
1N4764AG	ZM4764A	100	2.5	350	3000	0.25	5.0	76.0	9.0	45

Notes:

- (1) The Zener impedance is derived from the 1kHz AC voltage which results when an AC current having an RMS value equal to 10% of the Zener current (I_{ZT} or I_{ZK}) is superimposed on I_{ZT} or I_{ZK}. Zener impedance is measured at two points to ensure a sharp knee on the breakdown curve and to eliminate unstable units
- (2) Valid provided that electrodes are at a distance of 10mm from case and kept at ambient temperature
- (3) Measured under thermal equilibrium and DC test conditions
- (4) Standard Zener voltage tolerance is ± 5% tolerance. Other Zener voltages and tolerances are available upon request.
- (5) V_F = 1.2 Vmax. @ I_F = 200 mA



Zener Diodes 1 W

Type No.	Nominal Zener Voltage	Test Current	Maximum Zener Impedance			Maximum Reverse Leakage Current		Maximum DC Zener Current	Maximum Surge Current
	$V_Z @ I_{ZT}$	I_{ZT}	$Z_{ZT} @ I_{ZT}$	$Z_{ZK} @ I_{ZK}$	I_{ZK}	$I_R @ V_R$		I_{ZM}	$I_{RM}^{(2)}$
	(V)	(mA)		(Ω)	(mA)	(μ A)	(V)	(mA)	(mApk)

1SMA4728A Series, 1 W, Case Type : SMA

1SMA4728A	3.3	76.0	10	400	1.0	100	1.0	276	1380
1SMA4729A	3.6	69.0	10	400	1.0	100	1.0	252	1260
1SMA4730A	3.9	58.0	9.0	400	1.0	50	1.0	234	1190
1SMA4731A	4.3	58.0	9.0	400	1.0	10	1.0	217	1070
1SMA4732A	4.7	53.0	8.0	500	1.0	10	1.0	193	970
1SMA4733A	5.1	49.0	7.0	550	1.0	10	1.0	178	890
1SMA4734A	5.6	45.0	5.0	600	1.0	10	2.0	162	810
1SMA4735A	6.2	41.0	2.0	700	1.0	10	3.0	146	730
1SMA4736A	6.8	37.0	3.5	700	1.0	50	4.0	133	660
1SMA4737A	7.5	34.0	4.0	700	0.5	50	5.0	121	605
1SMA4738A	8.2	31.0	4.5	700	0.5	50	6.0	110	550
1SMA4739A	9.1	28.0	5.0	700	0.5	50	7.0	100	500
1SMA4740A	10	25.0	7.0	700	0.25	50	7.6	91	454
1SMA4741A	11	23.0	8.0	700	0.25	50	8.4	83	414
1SMA4742A	12	21.0	9.0	700	0.25	5.0	9.1	76	380
1SMA4743A	13	19.0	10	700	0.25	5.0	9.9	69	344
1SMA4744A	15	17.0	14	700	0.25	5.0	11.4	61	305
1SMA4745A	16	15.5	16	700	0.25	5.0	12.2	57	285
1SMA4746A	18	14.0	20	750	0.25	5.0	13.7	50	250
1SMA4747A	20	12.5	22	750	0.25	5.0	15.2	45	225
1SMA4748A	22	11.5	23	750	0.25	5.0	16.7	41	205
1SMA4749A	24	10.5	25	750	0.25	5.0	18.2	38	190
1SMA4750A	27	9.5	35	750	0.25	5.0	20.6	34	170
1SMA4751A	30	8.5	40	1000	0.25	5.0	22.8	30	150
1SMA4752A	33	7.5	45	1000	0.25	5.0	25.1	27	135
1SMA4753A	36	7.0	50	1000	0.25	5.0	27.4	25	125
1SMA4754A	39	6.5	60	1000	0.25	5.0	29.7	23	115
1SMA4755A	43	6.0	70	1500	0.25	5.0	32.7	22	110
1SMA4756A	47	5.5	80	1500	0.25	5.0	35.8	19	95
1SMA4757A	51	5.0	95	1500	0.25	5.0	38.8	18	90
1SMA4758A	56	4.5	110	2000	0.25	5.0	42.6	16	80
1SMA4759A	62	4.0	125	2000	0.25	5.0	47.1	14	70
1SMA4760A	68	3.7	150	2000	0.25	5.0	51.7	13	65
1SMA4761A	75	3.3	175	2000	0.25	5.0	56.0	12	60
1SMA4762A	82	3.0	200	3000	0.25	5.0	62.2	11	55
1SMA4763A	91	2.8	250	3000	0.25	5.0	69.2	10	50
1SMA4764A	100	2.5	350	3000	0.25	5.0	76.0	9.0	45

Notes :

(1) The type numbers listed have a standard tolerance on the nominal zener voltage of $\pm 5\%$.

(2) Surge current is a non-repetitive 8.3ms square pulse width wave or equivalent sine-wave superimposed on I_{ZT} as per JEDEC method



Zener Diodes 1 W

Type No.	Zener Voltage			Test Current	Maximum Zener Impedance		Maximum Reverse Current		Typical Temperature Coefficient	
	V_Z (V) ⁽¹⁾				I_{ZT}	Z_Z @	I_Z	I_R @	V_R	γ_Z
	Min.	Typ.	Max.	(mA)	(Ω)	(mA)	(μ A)	(V)	(mV/°C)	(mA)

PTZ3.6B Series, 1 W, Case Type : SMA



PTZ3.6B	3.6	3.813	4.00	40	15	40	60	1.0	-2.8	40
PTZ3.9B	3.9	4.136	4.40	40	15	40	40	1.0	-2.4	40
PTZ4.3B	4.3	4.572	4.80	40	15	40	20	1.0	-2.1	40
PTZ4.7B	4.7	4.924	5.20	40	10	40	20	1.0	-1.7	40
PTZ5.1B	5.1	5.368	5.70	40	8	40	20	1.5	-0.6	40
PTZ5.6B	5.6	5.856	6.30	40	8	40	20	2.5	1.4	40
PTZ6.2B	6.2	6.509	7.00	40	6	40	20	3.0	2.5	40
PTZ6.8B	6.8	7.280	7.70	40	6	40	20	3.5	3.2	40
PTZ7.5B	7.5	7.889	8.40	40	4	40	20	4.0	4.2	40
PTZ8.2B	8.2	8.655	9.30	40	4	40	20	5.0	5.0	40
PTZ9.1B	9.1	9.747	10.2	40	6	40	20	6.0	5.9	40
PTZ10B	10	10.31	11.2	40	6	40	10	7.0	6.9	40
PTZ11B	11	11.51	12.3	20	8	20	10	8.0	7.9	20
PTZ12B	12	12.50	13.5	20	8	20	10	9.0	8.7	20
PTZ13B	13.3	13.82	15.0	20	10	20	10	10.0	10.1	20
PTZ15B	14.7	15.35	16.5	20	10	20	10	11.0	11.8	20
PTZ16B	16.2	16.86	18.3	20	12	20	10	12.0	13.3	20
PTZ18B	18	19.00	20.3	20	12	20	10	13.0	15.0	20
PTZ20B	20	20.82	22.4	20	14	20	10	15.0	17.4	20
PTZ22B	22	23.85	24.5	10	14	10	10	17.0	19.4	10
PTZ24B	24	25.31	27.6	10	16	10	10	19.0	21.6	10
PTZ27B	27	28.70	30.8	10	16	10	10	21.0	24.6	10
PTZ30B	30	31.57	34.0	10	18	10	10	23.0	27.5	10
PTZ33B	33	34.95	37.0	10	18	10	10	25.0	30.8	10
PTZ36B	36	39.24	40.0	10	20	10	10	27.0	37.0	10

Note :

(1) The Zener Voltage V_Z is measured 40 ms after power is supplied

Zener Diodes 1 W

Type No.	Suffix ⁽³⁾	Zener Voltage $V_Z^{(1)}$			Dynamic Impedance $Z_Z^{(2)}$		Reverse Current I_R	
		Min.	Max.	I_Z	Max.	I_Z	Max.	V_R
		V	V	mA	Ω	mA	(μ A)	(V)

RD2.0F Series, 1 W, Case Type : DO-41 Glass



RD2.0F	B	1.88	2.25	40	25	40	200	0.5
	B1	1.88	2.12					
	B2	2.01	2.25					
RD2.2F	B	2.11	2.45	40	20	40	200	0.7
	B1	2.11	2.34					
	B2	2.21	2.45					
RD2.4F	B	2.31	2.65	40	15	40	200	1.0
	B1	2.31	2.55					
	B2	2.41	2.65					
RD2.7F	B	2.52	2.93	40	15	40	150	1.0
	B1	2.52	2.78					
	B2	2.68	2.93					
RD3.0F	B	2.83	3.22	40	15	40	100	1.0
	B1	2.83	3.07					
	B2	2.97	3.22					
RD3.3F	B	3.13	3.51	40	15	40	80	1.0
	B1	3.13	3.37					
	B2	3.27	3.51					
RD3.6F	B	3.43	3.83	40	15	40	60	1.0
	B1	3.43	3.68					
	B2	3.58	3.83					
RD3.9F	B	3.73	4.15	40	15	40	40	1.0
	B1	3.73	4.00					
	B2	3.88	4.15					
RD4.3F	B	4.03	4.55	40	15	40	20	1.0
	B1	4.03	4.28					
	B2	4.15	4.41					
	B3	4.28	4.55					
RD4.7F	B	4.41	4.91	40	10	40	20	1.0
	B1	4.41	4.65					
	B2	4.53	4.78					
	B3	4.66	4.91					
RD5.1F	B	4.79	5.38	40	8	40	20	1.0
	B1	4.79	5.05					
	B2	4.95	5.22					
	B3	5.10	5.38					
RD5.6F	B	5.28	5.95	40	8	40	20	1.5
	B1	5.28	5.56					
	B2	5.46	5.75					
	B3	5.65	5.95					
RD6.2F	B	5.76	6.52	40	6	40	20	3.0
	B1	5.76	6.14					
	B2	5.98	6.33					
	B3	6.17	6.52					

Zener Diodes 1 W

Type No.	Suffix ⁽³⁾	Zener Voltage $V_Z^{(1)}$			Dynamic Impedance $Z_Z^{(2)}$		Reverse Current I_R	
		Min.	Max.	I_Z	Max.	I_Z	Max.	V_R
		V	V	mA	Ω	mA	(μ A)	(V)

RD2.0F Series, 1 W, Case Type : DO-41 Glass



RD6.8F	B	6.35	7.10	40	6	40	20	3.5
	B1	6.35	6.71					
	B2	6.55	6.90					
	B3	6.74	7.10					
RD7.5F	B	6.93	7.80	40	4	40	20	4.0
	B1	6.93	7.33					
	B2	7.17	7.55					
	B3	7.39	7.80					
RD8.2F	B	7.58	8.54	40	4	40	20	5.0
	B1	7.58	8.03					
	B2	7.87	8.28					
	B3	8.12	8.54					
RD9.1F	B	8.34	9.38	40	6	40	20	6.0
	B1	8.34	8.80					
	B2	8.64	9.08					
	B3	8.91	9.38					
RD10F	B	9.16	10.40	40	6	40	10	7.0
	B1	9.16	9.67					
	B2	9.50	9.99					
	B3	9.83	10.40					
RD11F	B	10.22	11.43	20	8	20	10	8.0
	B1	10.22	10.75					
	B2	10.54	11.19					
	B3	10.87	11.43					
RD12F	B	11.19	12.41	20	8	20	10	8.0
	B1	11.19	11.77					
	B2	11.50	12.09					
	B3	11.80	12.41					
RD13F	B	12.19	13.83	20	10	20	10	10
	B1	12.19	12.85					
	B2	12.63	13.30					
	B3	13.11	13.83					
RD15F	B	13.55	15.26	20	10	20	10	11
	B1	13.55	14.28					
	B2	14.05	14.77					
	B3	14.52	15.26					
RD16F	B	14.98	16.71	20	12	20	10	12
	B1	14.98	15.75					
	B2	15.44	16.23					
	B3	15.89	16.71					
RD18F	B	16.37	18.55	20	12	20	10	13
	B1	16.37	17.27					
	B2	17.03	17.91					
	B3	17.64	18.55					

Zener Diodes 1 W

Type No.	Suffix ⁽³⁾	Zener Voltage $V_Z^{(1)}$			Dynamic Impedance $Z_Z^{(2)}$		Reverse Current I_R	
		Min.	Max.	I_Z	Max.	I_Z	Max.	V_R
		V	V	mA	Ω	mA	(μ A)	(V)

RD2.0F Series, 1 W, Case Type : DO-41 Glass



RD20F	B	18.26	20.84	20	14	20	10	15
	B1	18.26	19.21					
	B2	18.93	19.91					
	B3	19.59	20.84					
RD22F	B	20.45	22.86	10	14	10	10	17
	B1	20.45	21.51					
	B2	21.10	22.18					
	B3	21.75	22.86					
RD24F	B	22.44	25.14	10	16	10	10	19
	B1	22.44	23.59					
	B2	23.17	24.36					
	B3	23.90	25.14					
RD27F	B	24.63	28.43	10	16	10	10	21
	B1	24.63	26.10					
	B2	25.70	27.12					
	B3	26.72	28.43					
RD30F	B	27.43	31.26	10	18	10	10	23
	B1	27.43	29.09					
	B2	28.64	30.10					
	B3	29.57	31.26					
RD33F	B	30.35	34.15	10	18	10	10	25
	B1	30.35	31.97					
	B2	31.49	33.06					
	B3	32.39	34.15					
RD36F	B	33.24	37.01	10	20	10	10	27
	B1	33.24	34.94					
	B2	34.26	36.01					
	B3	35.19	37.01					
RD39F	B	36.11	40.80	10	20	10	10	30
	B1	36.11	38.00					
	B2	37.14	39.04					
	B3	38.13	40.80					
RD43F	B	40.00	45.00	10	50	10	5	33
RD47F	B	44.00	49.00	10	50	10	5	36
RD51F	B	48.00	54.00	10	50	10	5	39
RD56F	B	53.00	60.00	10	50	10	5	43
RD62F	B	58.00	66.00	10	50	10	5	47
RD68F	B	64.00	72.00	10	70	10	5	52
RD75F	B	70.00	79.00	10	90	10	5	57
RD82F	B	77.00	87.00	10	90	10	5	63

Notes:

- (1) Test with pulse (40 ms)
- (2) Z_Z is measured at I_Z given a very small AC Current Signal
- (3) When placing an order for an RD2.0F type, please add suffix e.g. RD2.0FB, RD2.0FB1 RD82FB4
The B grade is a wide specification, covering full voltage range for suffix "B1" to "B3"



Zener Diodes 1 W

Type No.	Zener Voltage ⁽²⁾ V _Z @ I _{ZT}				Maximum Zener Impedance			Maximum Reverse Leakage Current, I _R		Maximum DC Zener Current ⁽¹⁾ I _{ZM} (mA)
	Nom	Min	Max	I _{ZT}	Z _{ZT} @ I _{ZT}	Z _{ZK} @ I _{ZK}	I _{ZK}	I _R @ V _R		
	(V)	(V)	(V)	(mA)	(Ω)	(Ω)	(mA)	(μA) (V)		

SMAZ5V1 Series, 1 W, Case Type : SMA



SMAZ5V1	5.1	4.84	5.40	100	5.0	500	1.0	2.5	1.0	196
SMAZ5V6	5.6	5.32	5.88	100	2.0	250	2.0	5.0	2.0	179
SMAZ6V2	6.2	5.89	6.51	100	2.0	200	2.0	5.0	3.0	161
SMAZ6V8	6.8	6.46	7.14	100	2.0	200	1.0	5.0	4.0	147
SMAZ7V5	7.5	7.13	7.88	100	2.0	450	1.0	5.0	5.0	133
SMAZ8V2	8.2	7.79	8.61	100	2.0	200	1.0	5.0	6.0	122
SMAZ9V1	9.1	8.65	9.56	50	4.0	200	1.0	5.0	7.0	10
SMAZ10	10.0	9.50	10.50	50	4.0	200	1.0	1.0	7.6	100
SMAZ12	12.0	11.40	12.60	50	7.0	150	1.0	1.0	9.1	83
SMAZ15	15.0	14.25	15.75	50	10	150	1.0	1.0	11.4	67
SMAZ16	16.0	15.20	16.80	25	15	150	1.0	0.5	12.2	63
SMAZ18	18.0	17.10	18.90	25	15	150	1.0	0.5	13.7	56
SMAZ20	20.0	19.00	21.00	25	15	180	1.0	0.5	15.2	50
SMAZ22	22.0	20.90	23.10	25	15	180	1.0	0.5	16.7	45
SMAZ24	24.0	22.80	25.20	25	15	180	1.0	0.5	18.2	42
SMAZ27	27.0	25.65	28.35	25	15	200	1.0	0.5	20.5	37
SMAZ30	30.0	28.50	31.50	25	15	250	1.0	0.5	22.8	33
SMAZ33	33.0	31.35	34.65	25	15	300	1.0	0.5	25.1	30
SMAZ36	36.0	34.20	37.80	10	40	350	1.0	0.5	27.4	28
SMAZ39	39.0	37.05	40.95	10	40	450	1.0	0.5	29.6	26

Notes :

- (1) PCB mounted on 1" x 0.85" x 0.062" copper area pads
- (2) Short duration test pulse used to minimize self-heating effect
- (3) "SMA" will be omitted in marking on the diode.



Zener Diodes 1 W

Type No.	Nominal Zener Voltage		Maximum Zener Impedance			Maximum Reverse Leakage Current		Maximum DC Zener Current	Maximum Surge Current
	$V_Z^{(1)}$ @ I_{ZT}	I_{ZT}	Z_{ZT} @ I_{ZT}	Z_{ZK} @ I_{ZK}	I_{ZK}	I_R @ V_R		I_{ZM}	$I_{RM}^{(2)}$
	(V)	(mA)	(Ω)	(Ω)	(mA)	(μ A)	(V)	(mA)	(mApk)

SML4728 Series, 1 W, Case Type : SMA

SML4728	3.3	76.0	10	400	1.0	100	1.0	276	1380
SML4729	3.6	69.0	10	400	1.0	100	1.0	252	1260
SML4730	3.9	64.0	9.0	400	1.0	50	1.0	234	1190
SML4731	4.3	58.0	9.0	400	1.0	10	1.0	217	1070
SML4732	4.7	53.0	8.0	500	1.0	10	1.0	193	970
SML4733	5.1	49.0	7.0	550	1.0	10	1.0	178	890
SML4734	5.6	45.0	5.0	600	1.0	10	2.0	162	810
SML4735	6.2	41.0	2.0	700	1.0	10	3.0	146	730
SML4736	6.8	37.0	3.5	700	1.0	50	4.0	133	660
SML4737	7.5	34.0	4.0	700	0.5	50	5.0	121	605
SML4738	8.2	31.0	4.5	700	0.5	50	6.0	110	550
SML4739	9.1	28.0	5.0	700	0.5	50	7.0	100	500
SML4740	10	25.0	7.0	700	0.25	50	7.6	91	454
SML4741	11	23.0	8.0	700	0.25	50	8.4	83	414
SML4742	12	21.0	9.0	700	0.25	5.0	9.1	76	380
SML4743	13	19.0	10	700	0.25	5.0	9.9	69	344
SML4744	15	17.0	14	700	0.25	5.0	11.4	61	305
SML4745	16	15.5	16	700	0.25	5.0	12.2	57	285
SML4746	18	14.0	20	750	0.25	5.0	13.7	50	250
SML4747	20	12.5	22	750	0.25	5.0	15.2	45	225
SML4748	22	11.5	23	750	0.25	5.0	16.7	41	205
SML4749	24	10.5	25	750	0.25	5.0	18.2	38	190
SML4750	27	9.5	35	750	0.25	5.0	20.6	34	170
SML4751	30	8.5	40	1000	0.25	5.0	22.8	30	150
SML4752	33	7.5	45	1000	0.25	5.0	25.1	27	135
SML4753	36	7.0	50	1000	0.25	5.0	27.4	25	125
SML4754	39	6.5	60	1000	0.25	5.0	29.7	23	115
SML4755	43	6.0	70	1500	0.25	5.0	32.7	22	110
SML4756	47	5.5	80	1500	0.25	5.0	35.8	19	95
SML4757	51	5.0	95	1500	0.25	5.0	38.8	18	90
SML4758	56	4.5	110	2000	0.25	5.0	42.6	16	80
SML4759	62	4.0	125	2000	0.25	5.0	47.1	14	70
SML4760	68	3.7	150	2000	0.25	5.0	51.7	13	65
SML4761	75	3.3	175	2000	0.25	5.0	56.0	12	60
SML4762	82	3.0	200	3000	0.25	5.0	62.2	11	55
SML4763	91	2.8	250	3000	0.25	5.0	69.2	10	50
SML4764	100	2.5	350	3000	0.25	5.0	76.0	9.0	45

Notes :

- (1) Standard voltage tolerance is 10%, add suffix "A" for $\pm 5\%$ tolerance
- (2) Surge current is a non-repetitive 8.3ms square pulse width wave or equivalent sine-wave superimposed on I_{ZT} per JEDEC method
- (3) " SML " will be omitted on marking of the diode

Zener Diodes 1 W

The plastic material carries U/L recognition 94V-O.

Type No.	Zener Voltage ⁽¹⁾		Test Current	Dynamic Resistance at I_{ZT} $f = 1\text{kHz}$	Reverse Voltage at $I_R = 0.5\ \mu\text{A}$	Admissible Zener current ⁽²⁾	Temp. Coeff. of Zener Voltage at I_{ZT}	
	$V_Z @ I_{ZT}$						I_{ZT}	r_{zj}
	Min (V)	Max (V)	(mA)	(Ω)	(V)	(mA)		

ZMU Series, 1 W, Case Type : MELF



Type No.	Min (V)	Max (V)	I_{ZT} (mA)	Dynamic Resistance (Ω)	Reverse Voltage (V)	Admissible Zener current (mA)	Temp. Coeff. Min.	Temp. Coeff. Max.
ZMU100	88	110	5	140 (<300)	>75	7	9	13
ZMU120	107	134	5	170 (<330)	>90	6	9	13
ZMU150	130	165	5	200 (<360)	>112	5	9	13
ZMU180	160	200	5	220 (<380)	>134	4	9	13

ZMY Series, 1 W, Case Type : MELF



Type No.	Min (V)	Max (V)	I_{ZT} (mA)	Dynamic Resistance (Ω)	Reverse Voltage (V)	Admissible Zener current (mA)	Temp. Coeff. Min.	Temp. Coeff. Max.
ZMY3.9	3.7	4.1	100	4(<7)	-	203	-7	2
ZMY4.3	4.0	4.6	100	4(<7)	-	182	-7	3
ZMY4.7	4.4	5.0	100	4(<7)	-	165	-7	4
ZMY5.1	4.8	5.4	100	2(<5)	>0.7	150	-6	5
ZMY5.6	5.2	6.0	100	1(<2)	>1.5	135	-3	5
ZMY6.2	5.8	6.6	100	1(<2)	>2.0	128	-1	6
ZMY6.8	6.4	7.2	100	1(<2)	>3.0	110	0	7
ZMY7.5	7.0	7.9	100	1(<2)	>5.0	100	0	7
ZMY8.2	7.7	8.7	100	1(<2)	>6.0	89	3	8
ZMY9.1	8.5	9.6	50	2(<4)	>7.0	82	3	8
ZMY10	9.4	10.6	50	2(<4)	>7.5	74	5	9
ZMY11	10.4	11.6	50	3(<7)	>8.5	66	5	10
ZMY12	11.4	12.7	50	3(<7)	>9.0	60	5	10
ZMY13	12.4	14.1	50	4(<9)	>10	55	5	10
ZMY15	13.8	15.8	50	4(<9)	>11	49	5	10
ZMY16	15.3	17.1	25	5(<10)	>12	44	7	11
ZMY18	16.8	19.1	25	5(<11)	>14	40	7	11
ZMY20	18.8	21.2	25	6(<12)	>15	36	7	11
ZMY22	20.8	23.3	25	7(<13)	>17	34	7	11
ZMY24	22.8	25.6	25	8(<14)	>18	29	7	12
ZMY27	25.1	28.9	25	9(<15)	>20	27	7	12
ZMY30	28	32	25	10(<20)	>22.5	25	7	12
ZMY33	31	35	25	11(<20)	>25	22	7	12
ZMY36	34	38	10	25(<60)	>27	20	7	12
ZMY39	37	41	10	30(<60)	>29	18	8	12
ZMY43	40	46	10	35(<80)	>32	17	8	13
ZMY47	44	50	10	40(<80)	>35	15	8	13
ZMY51	48	54	10	45(<100)	>38	14	8	13
ZMY56	52	60	10	50(<100)	>42	13	8	13
ZMY62	58	66	10	60(<130)	>47	11	8	13
ZMY68	64	72	10	65(<130)	>51	10	8	13
ZMY75	70	79	10	70(<160)	>56	9.0	8	13
ZMY82	77	88	10	80(<160)	>61	8.0	8	13
ZMY91	85	96	5	120(<250)	>68	7.5	9	13
ZMY100	94	106	5	130(<250)	>75	7.0	9	13

Notes:

- (1) Tested with pulse $t_p = 5\text{ms}$
- (2) Valid provided that electrodes are kept at ambient temperature
- (3) For ZMY Series standard zener voltage tolerance is $\pm 5\%$. Add suffix "C" for $\pm 2\%$ tolerance.



Zener Diodes 1.3 W

The plastic material carries U/L recognition 94V-O.

Type No.		Nominal Zener Voltage		Maximum Zener Impedance			Maximum Reverse Leakage Current		Maximum DC Zener Current
		Vz @ IZT	IZT	ZzT @ IZT	Zzk @ Izk	Izk	IR @ VR	IZM	
Axial Lead	SMD	(V)	(mA)	(W)	(W)	(mA)	(mA)	(V)	(mA)

BZX85/SZ25 Series, 1.3 W, Case Type : DO-41/SMA

BZX85C2V4	SZ252D	2.4	80	20	400	1.0	150	1.0	410
BZX85C2V7	SZ252H	2.7	80	20	400	1.0	150	1.0	370
BZX85C3V0	SZ253A	3.0	80	20	400	1.0	100	1.0	340
BZX85C3V3	SZ253D	3.3	80	20	400	1.0	40	1.0	320
BZX85C3V6	SZ253G	3.6	70	20	500	1.0	20	1.0	290
BZX85C3V9	SZ253J	3.9	60	15	500	1.0	10	1.0	280
BZX85C4V3	SZ254D	4.3	50	13	500	1.0	3.0	1.0	250
BZX85C4V7	SZ254H	4.7	45	13	500	1.0	3.0	1.0	215
BZX85C5V1	SZ255B	5.1	45	10	500	1.0	1.0	1.5	200
BZX85C5V6	SZ255G	5.6	45	7.0	400	1.0	1.0	2.0	190
BZX85C6V2	SZ256C	6.2	35	4.0	300	1.0	1.0	3.0	170
BZX85C6V8	SZ256I	6.8	35	3.5	300	1.0	50	4.0	155
BZX85C7V5	SZ257F	7.5	35	3.0	200	0.5	50	4.5	140
BZX85C8V2	SZ258C	8.2	25	5.0	200	0.5	50	6.2	130
BZX85C9V1	SZ259B	9.1	25	5.0	200	0.5	50	6.8	120
BZX85C10	SZ2510	10	25	7.0	200	0.5	0.5	7.5	105
BZX85C11	SZ2511	11	20	8.0	300	0.5	0.5	8.2	97
BZX85C12	SZ2512	12	20	9.0	350	0.5	0.5	9.1	88
BZX85C13	SZ2513	13	20	10	400	0.5	0.5	10	79
BZX85C15	SZ2515	15	15	15	500	0.5	0.5	11	71
BZX85C16	SZ2516	16	15	15	500	0.5	0.5	12	66
BZX85C18	SZ2518	18	15	20	500	0.5	0.5	13	62
BZX85C20	SZ2520	20	10	24	600	0.5	0.5	15	56
BZX85C22	SZ2522	22	10	25	600	0.5	0.5	16	52
BZX85C24	SZ2524	24	10	25	600	0.5	0.5	18	47
BZX85C27	SZ2527	27	8.0	30	750	0.25	0.5	20	41
BZX85C30	SZ2530	30	8.0	30	1000	0.25	0.5	22	36
BZX85C33	SZ2533	33	8.0	35	1000	0.25	0.5	24	33
BZX85C36	SZ2536	36	8.0	40	1000	0.25	0.5	27	30
BZX85C39	SZ2539	39	6.0	50	1000	0.25	0.5	30	28
BZX85C43	SZ2543	43	6.0	50	1000	0.25	0.5	33	26
BZX85C47	SZ2547	47	4.0	90	1500	0.25	0.5	36	23
BZX85C51	SZ2551	51	4.0	115	1500	0.25	0.5	39	21
BZX85C56	SZ2556	56	4.0	120	2000	0.25	0.5	43	19
BZX85C62	SZ2562	62	4.0	125	2000	0.25	0.5	47	16
BZX85C68	SZ2568	68	4.0	130	2000	0.25	0.5	51	15
BZX85C75	SZ2575	75	4.0	135	2000	0.25	0.5	56	14
BZX85C82	SZ2582	82	2.7	200	3000	0.25	0.5	62	12
BZX85C91	SZ2591	91	2.7	250	3000	0.25	0.5	68	10
BZX85C100	SZ25B0	100	2.7	350	3000	0.25	0.5	75	9.4
BZX85C110	SZ25B1	110	2.7	450	4000	0.25	0.5	82	8.6
BZX85C120	SZ25B2	120	2.0	550	4500	0.25	0.5	91	7.8
BZX85C130	SZ25B3	130	2.0	700	5000	0.25	0.5	100	7.0
BZX85C150	SZ25B5	150	2.0	1000	6000	0.25	0.5	110	6.4
BZX85C160	SZ25B6	160	1.5	1100	6500	0.25	0.5	120	5.8
BZX85C180	SZ25B8	180	1.5	1200	7000	0.25	0.5	130	5.2
BZX85C200	SZ25D0	200	1.5	1500	8000	0.25	0.5	150	4.7

Notes:

- (1) $V_F = 1.2 V_{max}$ @ $I_F = 200 \text{ mA}$.
- (2) The type numbers listed have a standard tolerance on the nominal zener voltage of $\pm 5\%$. Add suffix "B" for $\pm 2\%$ tolerance for axial lead.
- (3) "BZX" for Axial Lead / "SZ" for SMD will be omitted on marking of the diode.



Zener Diodes 1.3 W

Type No.		Nominal Zener Voltage		Maximum Zener Impedance			Maximum Reverse Leakage Current		Maximum DC Zener Current
		$V_Z @ I_{ZT}$	I_{ZT}	$Z_{ZT} @ I_{ZT}$	$Z_{ZK} @ I_{ZK}$	I_{ZK}	$I_R @ V_R$	V_R	I_{ZM}
Axial Lead	SMD	(V)	(mA)	(Ω)	(Ω)	(mA)	(μ A)	(V)	(mA)

MZ85C/SMZ253A Series, 1.3 W, Case Type : M1A/SOD-123FL



MZ85C3V0	SMZ253A	3.0	80	20	400	1.0	100	1.0	340
MZ85C3V3	SMZ253D	3.3	80	20	400	1.0	40	1.0	320
MZ85C3V6	SMZ253G	3.6	70	20	500	1.0	20	1.0	290
MZ85C3V9	SMZ253J	3.9	60	15	500	1.0	10	1.0	280
MZ85C4V3	SMZ254D	4.3	50	13	500	1.0	3.0	1.0	250
MZ85C4V7	SMZ254H	4.7	45	13	500	1.0	3.0	1.0	215
MZ85C5V1	SMZ255B	5.1	45	10	500	1.0	1.0	1.5	200
MZ85C5V6	SMZ255G	5.6	45	7.0	400	1.0	1.0	2.0	190
MZ85C6V2	SMZ256C	6.2	35	4.0	300	1.0	1.0	3.0	170
MZ85C6V8	SMZ256I	6.8	35	3.5	300	1.0	50	4.0	155
MZ85C7V5	SMZ257F	7.5	35	3.0	200	0.5	50	4.5	140
MZ85C8V2	SMZ258C	8.2	25	5.0	200	0.5	50	6.2	130
MZ85C9V1	SMZ259B	9.1	25	5.0	200	0.5	50	6.8	120
MZ85C10	SMZ2510	10	25	7.0	200	0.5	50	7.5	105
MZ85C11	SMZ2511	11	20	8.0	300	0.5	50	8.2	97
MZ85C12	SMZ2512	12	20	9.0	350	0.5	0.5	9.1	88
MZ85C13	SMZ2513	13	20	10	400	0.5	0.5	10	79
MZ85C15	SMZ2515	15	15	15	500	0.5	0.5	11	71
MZ85C16	SMZ2516	16	15	15	500	0.5	0.5	12	66
MZ85C18	SMZ2518	18	15	20	500	0.5	0.5	13	62
MZ85C19	SMZ2519	19	15	20	550	0.5	0.5	14	58
MZ85C20	SMZ2520	20	10	24	600	0.5	0.5	15	56
MZ85C22	SMZ2522	22	10	25	600	0.5	0.5	16	52
MZ85C24	SMZ2524	24	10	25	600	0.5	0.5	18	47
MZ85C27	SMZ2527	27	8.0	30	750	0.25	0.5	20	41
MZ85C30	SMZ2530	30	8.0	30	1000	0.25	0.5	22	36
MZ85C33	SMZ2533	33	8.0	35	1000	0.25	0.5	24	33
MZ85C36	SMZ2536	36	8.0	40	1000	0.25	0.5	27	30
MZ85C39	SMZ2539	39	6.0	50	1000	0.25	0.5	30	28
MZ85C43	SMZ2543	43	6.0	50	1000	0.25	0.5	33	26
MZ85C47	SMZ2547	47	4.0	90	1500	0.25	0.5	36	23
MZ85C51	SMZ2551	51	4.0	115	1500	0.25	0.5	39	21
MZ85C56	SMZ2556	56	4.0	120	2000	0.25	0.5	43	19
MZ85C62	SMZ2562	62	4.0	125	2000	0.25	0.5	47	16
MZ85C68	SMZ2568	68	4.0	130	2000	0.25	0.5	51	15
MZ85C75	SMZ2575	75	4.0	135	2000	0.25	0.5	56	14
MZ85C82	SMZ2582	82	2.7	200	3000	0.25	0.5	62	12
MZ85C91	SMZ2591	91	2.7	250	3000	0.25	0.5	68	10
MZ85C100	SMZ25B0	100	2.7	350	3000	0.25	0.5	75	9.4
MZ85C110	SMZ25B1	110	2.7	450	4000	0.25	0.5	82	8.6
MZ85C120	SMZ25B2	120	2.0	550	4500	0.25	0.5	91	7.8
MZ85C130	SMZ25B3	130	2.0	700	5000	0.25	0.5	100	7.0
MZ85C150	SMZ25B5	150	2.0	1000	6000	0.25	0.5	110	6.4
MZ85C160	SMZ25B6	160	1.5	1100	6500	0.25	0.5	120	5.8
MZ85C180	SMZ25B8	180	1.5	1200	7000	0.25	0.5	130	5.2
MZ85C200	SMZ25D0	200	1.5	1900	9990	0.25	0.5	150	4.7

Note :

(1) The type number listed have a standard tolerance on the nominal zener voltage of $\pm 5.0\%$.

Zener Diodes 1.3 W

The plastic material carries U/L recognition 94V-0.

Type No.	Zener Voltage ⁽¹⁾ V _Z @ I _{ZT}		Test Current	Dynamic Resistance at I _{ZT} , f = 1kHz	Reverse Voltage at I _R = 0.5mA	Admissible Zener Current	Temp. coefficient of Zener Voltage	
	Min.	Max.	I _{ZT}	rzj (Ω)	V _R	I _Z ⁽²⁾	α _{vz} (10 ⁻⁴ / °C)	
	(V)	(V)	(mA)		(V)	(mA)	min.	max.

ZPY Series, 1.3 W, Case Type : DO-41 Glass



ZPY3.9	3.7	4.1	100	4 (< 7)	-	290	-7	+2
ZPY4.3	4.0	4.6	100	4 (< 7)	-	280	-7	+3
ZPY4.7	4.4	5.0	100	2 (< 5)	-	250	-7	+4
ZPY5.1	4.8	6.4	100	1 (< 2)	> 0.7	215	-6	+5
ZPY5.6	5.2	6.0	100	1 (< 2)	> 1.5	200	-3	+5
ZPY6.2	5.8	6.6	100	1 (< 2)	> 2.0	190	-1	+6
ZPY6.8	6.4	7.2	100	1 (< 2)	> 3.0	170	0	+7
ZPY7.5	7.0	7.9	100	1 (< 2)	> 5.0	155	0	+7
ZPY8.2	7.7	8.7	100	1 (< 2)	> 6.0	140	+3	+8
ZPY9.1	8.5	9.6	50	2 (< 4)	> 7.0	130	+3	+8
ZPY10	9.41	10.6	50	2 (< 4)	> 7.5	120	+5	+9
ZPY11	10.4	11.6	50	3 (< 7)	> 8.5	105	+5	+10
ZPY12	11.4	12.7	50	3 (< 7)	> 9.0	97	+5	+10
ZPY13	12.4	14.1	50	4 (< 9)	> 10	88	+5	+10
ZPY15	13.8	15.8	50	4 (< 9)	> 11	79	+5	+10
ZPY16	15.3	17.1	25	5 (< 10)	> 12	71	+7	+11
ZPY18	16.8	19.1	25	5 (< 11)	> 14	66	+7	+11
ZPY20	18.8	21.2	25	6 (< 12)	> 15	62	+7	+11
ZPY22	20.8	23.3	25	7 (< 13)	> 17		+7	+11
ZPY24	22.8	25.6	25	8 (< 14)	> 18	56	+7	+12
ZPY27	25.1	28.9	25	9 (< 15)	> 20	52	+7	+12
ZPY30	28	32	25	10 (< 20)	> 22.5	47	+7	+12
ZPY33	31	35	25	11 (< 20)	> 25	41	+7	+12
ZPY36	34	38	10	25 (< 60)	> 27	36	+7	+12
ZPY39	37	41	10	30 (< 60)	> 29	33	+8	+12
ZPY43	40	46	10	35 (< 80)	> 32	30	+8	+13
ZPY47	44	50	10	40 (< 80)	> 35	28	+8	+13
ZPY51	48	64	10	45 (< 100)	> 38	26	+8	+13
ZPY56	52	60	10	50 (< 100)	> 42	23	+8	+13
ZPY62	58	66	10	60 (< 130)	> 47	21	+8	+13
ZPY68	64	72	10	65 (< 130)	> 51	19	+8	+13
ZPY75	70	79	10	70 (< 160)	> 56	16	+8	+13
ZPY82	77	88	10	80 (< 160)	> 61	15	+8	+13
ZPY91	85	96	5	120 (< 250)	> 68	14	+9	+13
ZPY100	94	106	5	130 (< 250)	> 75	12	+9	+13

Notes:

(1) Tested with pulse tp = 5 ms

(2) Valid provided that leads are kept at ambient temperature at a distance of 10 mm from case.

For devices in glass DO-41 case with higher Zener voltage but same power dissipation see types ZPU100 ... ZPU180



Zener Diodes 1.5 W

The plastic material carries U/L recognition 94V-O.

Type No.		Nominal Zener Voltage		Maximum Zener Impedance			Maximum Reverse Leakage Current		Maximum DC Zener Current
		Vz @ IzT	IzT	ZzT @ IzT	ZzK @ IzK	IzK	IR @ VR	IzM	
Axial Lead	SMD	(V)	(mA)	(Ω)	(Ω)	(mA)	(μA)	(V)	(mA)

MZ5913A/SMZ35 Series, 1.5 W, Case Type : M1A/SOD-123FL



MZ5913A	SMZ353D	3.3	113.6	10.0	500	1.0	100	1.0	454
MZ5914A	SMZ353G	3.6	104.2	9.0	500	1.0	75	1.0	416
MZ5915A	SMZ353J	3.9	96.1	7.5	500	1.0	25	1.0	384
MZ5916A	SMZ354D	4.3	87.2	6.0	500	1.0	5.0	1.0	348
MZ5917A	SMZ354H	4.7	79.8	5.0	500	1.0	5.0	1.5	319
MZ5918A	SMZ355B	5.1	73.5	4.0	350	1.0	5.0	2.0	294
MZ5919A	SMZ355G	5.6	66.9	2.0	250	1.0	5.0	3.0	267
MZ5920A	SMZ356C	6.2	60.5	2.0	200	1.0	5.0	4.0	241
MZ5921A	SMZ356I	6.8	55.1	2.5	200	1.0	5.0	5.2	220
MZ5922A	SMZ357F	7.5	50.0	3.0	400	0.5	5.0	6.0	200
MZ5923A	SMZ358C	8.2	45.7	3.5	400	0.5	5.0	6.5	182
MZ5924A	SMZ359B	9.1	41.2	4.0	500	0.5	5.0	7.0	164
MZ5925A	SMZ3510	10	37.5	4.5	500	0.25	5.0	8.0	150
MZ5926A	SMZ3511	11	34.1	5.5	550	0.25	1.0	8.4	136
MZ5927A	SMZ3512	12	31.2	6.5	550	0.25	1.0	9.1	125
MZ5928A	SMZ3513	13	28.8	7.0	550	0.25	1.0	9.9	115
MZ5929A	SMZ3515	15	25.0	9.0	600	0.25	1.0	11.4	100
MZ5930A	SMZ3516	16	23.4	10	600	0.25	1.0	12.2	93
MZ5931A	SMZ3518	18	20.8	12	650	0.25	1.0	13.7	83
MZ5932A	SMZ3520	20	18.7	14	650	0.25	1.0	15.2	75
MZ5933A	SMZ3522	22	17.0	17.5	650	0.25	1.0	16.7	68
MZ5934A	SMZ3524	24	15.6	19	700	0.25	1.0	18.2	62
MZ5935A	SMZ3527	27	13.9	23	700	0.25	1.0	20.6	55
MZ5936A	SMZ3530	30	12.5	26	750	0.25	1.0	22.8	50
MZ5937A	SMZ3533	33	11.4	33	800	0.25	1.0	25.1	45
MZ5938A	SMZ3536	36	10.4	38	850	0.25	1.0	27.4	41
MZ5939A	SMZ3539	39	9.6	45	900	0.25	1.0	29.7	38
MZ5940A	SMZ3543	43	8.7	53	950	0.25	1.0	32.7	34
MZ5941A	SMZ3547	47	8.0	67	1000	0.25	1.0	35.8	31
MZ5942A	SMZ3551	51	7.3	70	1100	0.25	1.0	38.8	29
MZ5943A	SMZ3556	56	6.7	86	1300	0.25	1.0	42.6	26
MZ5944A	SMZ3562	62	6.0	100	1500	0.25	1.0	47.1	24
MZ5945A	SMZ3568	68	5.5	120	1700	0.25	1.0	51.7	22
MZ5946A	SMZ3575	75	5.0	140	2000	0.25	1.0	56.0	20
MZ5947A	SMZ3582	82	4.6	160	2500	0.25	1.0	62.2	18
MZ5948A	SMZ3591	91	4.1	200	3000	0.25	1.0	69.2	16
MZ5949A	SMZ35B0	100	3.7	250	3100	0.25	1.0	76.0	15
MZ5950A	SMZ35B1	110	3.4	300	4000	0.25	1.0	83.6	13
MZ5951A	SMZ35B2	120	3.1	380	4500	0.25	1.0	91.2	12
MZ5952A	SMZ35B3	130	2.9	450	5000	0.25	1.0	98.8	11
MZ5953A	SMZ35B5	150	2.5	600	6000	0.25	1.0	114.0	10
MZ5954A	SMZ35B6	160	2.3	700	6500	0.25	1.0	121.6	9.0
MZ5955A	SMZ35B8	180	2.1	900	7000	0.25	1.0	136.8	8.0
MZ5956A	SMZ35D0	200	1.9	1200	8000	0.25	1.0	152.0	7.0

Note :

(1) Suffix "A" is for $\pm 10\%$ tolerance. Use suffix "B" for $\pm 5\%$ tolerance (Axial lead) /

The type number listed have a standard tolerance on the nominal zener voltage of $\pm 5.0\%$.SMD)



Zener Diodes 1.5 W

The plastic material carries U/L recognition 94V-O.

Type No.	Nominal Zener Voltage	Test Current	Maximum Zener Impedance			Maximum Reverse Leakage Current		Maximum DC Zener Current
	$V_Z @ I_{ZT}$	I_{ZT}	$Z_{ZT} @ I_{ZT}$	$Z_{ZK} @ I_{ZK}$	I_{ZK}	$I_R @ V_R$		I_{ZM}
	(V)	(mA)		(Ω)	(mA)	(μ A)	(V)	(mA)

1SMA5913A Series, 1.5 W, Case Type : SMA

1SMA5913A	3.3	113.6	10	500	1.0	100	1.0	454
1SMA5914A	3.6	104.2	9.0	500	1.0	75	1.0	416
1SMA5915A	3.9	96.1	7.5	500	1.0	25	1.0	384
1SMA5916A	4.3	87.2	6.0	500	1.0	5.0	1.0	348
1SMA5917A	4.7	79.8	5.0	500	1.0	5.0	1.5	319
1SMA5918A	5.1	73.5	4.0	500	1.0	5.0	2.0	294
1SMA5919A	5.6	66.9	2.0	500	1.0	5.0	3.0	267
1SMA5920A	6.2	60.5	2.0	200	1.0	5.0	4.0	241
1SMA5921A	6.8	55.1	2.5	200	1.0	50	5.2	220
1SMA5922A	7.5	50.0	3.0	400	0.5	50	6.0	200
1SMA5923A	8.2	45.7	3.5	400	0.5	50	6.5	182
1SMA5924A	9.1	41.2	4.0	500	0.5	50	7.0	164
1SMA5925A	10	37.5	4.5	500	0.25	50	8.0	150
1SMA5926A	11	34.1	5.5	550	0.25	50	8.4	136
1SMA5927A	12	31.2	6.5	550	0.25	1.0	9.1	125
1SMA5928A	13	28.8	7.0	550	0.25	1.0	9.9	115
1SMA5929A	15	25.0	9.0	600	0.25	1.0	11.4	100
1SMA5930A	16	23.4	10	600	0.25	1.0	12.2	93
1SMA5931A	18	20.8	12	650	0.25	1.0	13.7	83
1SMA5932A	20	18.7	14	650	0.25	1.0	15.2	75
1SMA5933A	22	17.0	17.5	650	0.25	1.0	16.7	68
1SMA5934A	24	15.6	19	700	0.25	1.0	18.2	62
1SMA5935A	27	13.9	23	700	0.25	1.0	20.6	55
1SMA5936A	30	12.5	26	750	0.25	1.0	22.8	50
1SMA5937A	33	11.4	33	800	0.25	1.0	25.1	45
1SMA5938A	36	10.4	38	850	0.25	1.0	27.4	41
1SMA5939A	39	9.6	45	900	0.25	1.0	29.7	38
1SMA5940A	43	8.7	53	950	0.25	1.0	32.7	34
1SMA5941A	47	8.0	67	1000	0.25	1.0	35.8	31
1SMA5942A	51	7.3	70	1100	0.25	1.0	38.8	29
1SMA5943A	56	6.7	86	1300	0.25	1.0	42.6	26
1SMA5944A	62	6.0	100	1500	0.25	1.0	47.1	24
1SMA5945A	68	5.5	120	1700	0.25	1.0	51.7	22
1SMA5946A	75	5.0	140	2000	0.25	1.0	56.0	20
1SMA5947A	82	4.6	160	2500	0.25	1.0	62.2	18
1SMA5948A	91	4.1	200	3000	0.25	1.0	69.2	16
1SMA5949A	100	3.7	250	3100	0.25	1.0	76.0	15
1SMA5950A	110	3.4	300	4000	0.25	1.0	83.6	13
1SMA5951A	120	3.1	380	4500	0.25	1.0	91.2	12
1SMA5952A	130	2.9	450	5000	0.25	1.0	98.8	11
1SMA5953A	150	2.5	600	6000	0.25	1.0	114.0	10
1SMA5954A	160	2.3	700	6500	0.25	1.0	121.6	9.0
1SMA5955A	180	2.1	900	7000	0.25	1.0	136.8	8.0
1SMA5956A	200	1.9	1200	8000	0.25	1.0	152.0	7.0
1SMA5957A	240	1.5	1600	9000	0.25	1.0	182.4	6.0

Notes: (1) Suffix "A" indicates $\pm 10\%$ tolerance, change to suffix "B" for $\pm 5\%$ tolerance.

(2) "1SMA5" will be omitted in marking on the diode.



Zener Diodes 2 W

The plastic material carries U/L recognition 94V-O.

Type No.		Nominal Zener Voltage		Maximum Zener Impedance			Maximum Reverse Leakage Current		Maximum DC Zener Current
		Vz @ IZT	IZT	ZzT @ IZT	Zzk @ Izk	Izk	IR @ VR	IZM	
Axial Lead	SMD	(V)	(mA)	(Ω)	(Ω)	(mA)	(μA)	(V)	(mA)

2EZ / SZ45 Series, 2.0 W, Case Type : DO-41/SMA

2EZ2.7D5	SZ452H	2.7	80	10	400	1.0	100	1.0	660
2EZ3.0D5	SZ453A	3.0	160	8.0	400	1.0	100	1.0	600
2EZ3.3D5	SZ453D	3.3	145	8.0	400	1.0	80	1.0	545
2EZ3.6D5	SZ453G	3.6	139	5.0	400	1.0	80	1.0	504
2EZ3.9D5	SZ453J	3.9	128	5.0	400	1.0	30	1.0	468
2EZ4.3D5	SZ454D	4.3	116	4.5	400	1.0	20	1.0	434
2EZ4.7D5	SZ454H	4.7	106	4.5	550	1.0	5.0	1.0	386
2EZ5.1D5	SZ455B	5.1	98.0	3.5	600	1.0	5.0	1.0	356
2EZ5.6D5	SZ455G	5.6	89.5	2.5	500	1.0	5.0	2.0	324
2EZ6.2D5	SZ456C	6.2	80.5	1.5	700	1.0	5.0	3.0	292
2EZ6.8D5	SZ456I	6.8	73.5	2.0	700	1.0	50	4.0	266
2EZ7.5D5	SZ457F	7.5	66.5	2.0	700	0.5	50	5.0	242
2EZ8.2D5	SZ458C	8.2	61.0	2.3	700	0.5	50	6.0	220
2EZ9.1D5	SZ459B	9.1	55.0	2.5	700	0.5	50	7.0	200
2EZ10D5	SZ4510	10	50.0	3.5	700	0.25	50	7.6	182
2EZ11D5	SZ4511	11	45.5	4.0	700	0.25	50	8.4	166
2EZ12D5	SZ4512	12	41.5	4.5	700	0.25	50	9.1	152
2EZ13D5	SZ4513	13	38.5	5.0	700	0.25	0.5	9.9	138
2EZ14D5	SZ4514	14	35.7	5.5	700	0.25	0.5	10.6	130
2EZ15D5	SZ4515	15	33.4	7.0	700	0.25	0.5	11.4	122
2EZ16D5	SZ4516	16	31.2	8.0	700	0.25	0.5	12.2	114
2EZ17D5	SZ4517	17	29.4	9.0	750	0.25	0.5	13.0	107
2EZ18D5	SZ4518	18	27.8	10	750	0.25	0.5	13.7	100
2EZ19D5	SZ4519	19	26.3	11	750	0.25	0.5	14.4	95
2EZ20D5	SZ4520	20	25.0	11	750	0.25	0.5	15.2	90
2EZ22D5	SZ4522	22	22.8	12	750	0.25	0.5	16.7	82
2EZ24D5	SZ4524	24	20.8	13	750	0.25	0.5	18.2	76
2EZ27D5	SZ4527	27	18.5	18	750	0.25	0.5	20.6	68
2EZ30D5	SZ4530	30	16.6	20	1000	0.25	0.5	22.5	60
2EZ33D5	SZ4533	33	15.1	23	1000	0.25	0.5	25.1	55
2EZ36D5	SZ4536	36	13.9	25	1000	0.25	0.5	27.4	50
2EZ39D5	SZ4539	39	12.8	30	1000	0.25	0.5	29.7	47
2EZ43D5	SZ4543	43	11.6	35	1500	0.25	0.5	32.7	43
2EZ47D5	SZ4547	47	10.6	40	1500	0.25	0.5	35.8	39
2EZ51D5	SZ4551	51	9.8	48	1500	0.25	0.5	38.8	36
2EZ56D5	SZ4556	56	9.0	55	2000	0.25	0.5	42.6	32
2EZ62D5	SZ4562	62	8.1	60	2000	0.25	0.5	47.1	29
2EZ68D5	SZ4568	68	7.4	75	2000	0.25	0.5	51.7	27
2EZ75D5	SZ4575	75	6.7	90	2000	0.25	0.5	56.0	24
2EZ82D5	SZ4582	82	6.1	100	3000	0.25	0.5	62.2	22
2EZ91D5	SZ4591	91	5.5	125	3000	0.25	0.5	69.2	20
2EZ100D5	SZ45B0	100	5.0	175	3000	0.25	0.5	76.0	18
2EZ110D5	SZ45B1	110	4.5	250	4000	0.25	0.5	83.6	17
2EZ120D5	SZ45B2	120	4.2	325	4500	0.25	0.5	91.2	15
2EZ130D5	SZ45B3	130	3.8	400	5000	0.25	0.5	98.8	14
2EZ140D5	SZ45B4	140	3.6	500	5500	0.25	0.5	106.4	13
2EZ150D5	SZ45B5	150	3.3	575	6000	0.25	0.5	114.0	12
2EZ160D5	SZ45B6	160	3.1	650	6500	0.25	0.5	121.6	11
2EZ170D5	SZ45B7	170	2.9	675	7000	0.25	0.5	130.4	11
2EZ180D5	SZ45B8	180	2.8	725	7000	0.25	0.5	136.8	10
2EZ190D5	SZ45B9	190	2.6	825	8000	0.25	0.5	144.8	10
2EZ200D5	SZ45D0	200	2.5	900	8000	0.25	0.5	152.0	9.0
2EZ220D5	SZ45D2	220	2.0	2000	8500	0.25	0.5	167	8.0
2EZ270D5	SZ45D7	270	1.6	2200	8500	0.25	0.5	205	6.7
2EZ300D5	SZ45E0	300	1.5	2200	9000	0.25	0.5	228	5.9
2EZ330D5	SZ45E3	330	1.4	2300	9000	0.25	0.5	250	5.4

Notes :

- (1) For Vz ≤ 200 V; VF = 1.2 Vmax. @ IF = 200 mA and for Vz > 200 V; VF = 2 Vmax. @ IF = 200 mA.
- (2) Suffix "5" indicates ± 5% tolerance, suffix "10" indicates ± 10% tolerance (Axial lead) / replace the fourth digit of type from "0" for ± 10% tolerance to "5" for ± 5% tolerance (SMD)
- (3) "EZ" for Axial Lead / "SZ" for SMD will be omitted on marking of the diode

Zener Diodes 2 W

The plastic material carries U/L recognition 94V-0.

Type No.	Zener Voltage ⁽²⁾ at I_{ZT}		Test Current	Dynamic resistance at I_{ZT}	Temp. coeff. of Zener Voltage at I_{ZT}	Maximum Reverse at $I_R = 1 \mu\text{A}$	Admissible Zener Current ⁽¹⁾ at $T_a = 25^\circ\text{C}$
	V_Z (V)						
	min.	max.	I_{ZT} (mA)	max. rzj (Ω)	α_{VZ} ($10^{-4}/\text{K}$)	V_R (V)	I_Z (mA)

ZY3.6 Series, 2 W, Case Type : DO-41



ZY3.6	3.4	3.8	100	7	-7...+2	-	440
ZY3.9	3.7	4.1	100	7	-7...+2	-	410
ZY4.3	4.0	4.6	100	7	-7...+3	s	360
ZY4.7	4.4	5.0	100	7	-7...+4	-	330
ZY5.1	4.8	5.4	100	5	-6...+5	-	300
ZY5.6	5.2	6.0	100	2	-3...+5	>1.5	275
ZY6.2	5.8	6.6	100	2	-1...+6	>1.5	245
ZY6.8	6.4	7.2	100	1	0...+7	>2.0	220
ZY7.5	7.0	7.9	100	1	0...+7	>2.0	200
ZY8.2	7.7	8.7	100	1	+3...+8	>3.5	180
ZY9.1	8.5	9.6	50	4	+3...+8	>7.4	165
ZY10	9.4	10.6	50	4	+5...+9	>8.2	145
ZY11	10.4	11.6	50	7	+5...+10	>9.2	135
ZY12	11.4	12.7	50	7	+5...+10	>10	120
ZY13	12.4	14.1	50	10	+5...+10	>10.7	110
ZY15	13.8	15.8	50	10	+5...+10	>12	98
ZY16	15.3	17.1	25	15	+6...+11	>13.3	90
ZY18	16.8	19.1	25	15	+6...+11	>14.7	80
ZY20	18.8	21.2	25	15	+6...+11	>16.5	72
ZY22	20.8	23.3	25	15	+6...+11	>18.3	66
ZY24	22.8	25.6	25	15	+6...+11	>20.1	60
ZY27	25.1	28.9	25	15	+6...+11	>22.5	53
ZY30	28	32	25	15	+6...+11	>25.1	48
ZY33	31	35	25	15	+6...+11	>27.8	44
ZY36	34	38	10	40	+6...+11	>30.2	40
ZY39	37	41	10	40	+6...+11	>32.9	37
ZY43	40	46	10	45	+7...+12	>35.6	33
ZY47	44	50	10	45	+7...+12	>39.2	30
ZY51	48	54	10	60	+7...+12	>42.8	27
ZY56	52	60	10	60	+7...+12	>47.3	25
ZY62	58	66	10	80	+8...+13	>51.7	21
ZY68	64	72	10	80	+8...+13	>57.1	20
ZY75	70	79	10	100	+8...+13	>63.2	18
ZY82	77	88	10	100	+8...+13	>68.6	16
ZY91	85	96	5	200	+9...+13	>75.7	15
ZY100	94	106	5	200	+9...+13	>83.7	13
ZY110	104	116	5	250	+9...+13	>92.6	12
ZY120	114	127	5	250	+9...+13	>101.6	11
ZY130	124	141	5	300	+9...+13	>110.5	10
ZY150	138	156	5	300	+9...+13	>123	9
ZY160	153	171	5	350	+9...+13	>136	8.5
ZY180	168	191	5	350	+9...+13	>149	8
ZY200	168	212	5	350	+9 ... +13	>167	7.5

Notes :

(1) Valid provided that leads are kept at ambient temperature at a distance of 10 mm from case

(2) Tested with pulse $t_p = 5$ ms



Zener Diodes 3 W

The plastic material carries U/L recognition 94V-O.

Type No.		Nominal Zener Voltage		Maximum Zener Impedance			Maximum Reverse Leakage Current		Maximum DC Zener Current
		Vz @ IZT	IZT	ZzT @ IZT	ZzK @ IZK	IZK	IR @ VR	IZM	
Axial Lead	SMD	(V)	(mA)	(Ω)	(Ω)	(mA)	(μA)	(V)	(mA)

1N5913A/SZ303D Series, 3.0/1.5 W, Case Type : DO-14/SMA

1N5913A	SZ303D	3.3	113.6	10.0	500	1.0	100	1.0	454
1N5914A	SZ303G	3.6	104.2	9.0	500	1.0	75	1.0	416
1N5915A	SZ303J	3.9	96.1	7.5	500	1.0	25	1.0	384
1N5916A	SZ304D	4.3	87.2	6.0	500	1.0	5.0	1.0	348
1N5917A	SZ304H	4.7	79.8	5.0	500	1.0	5.0	1.5	319
1N5918A	SZ305B	5.1	73.5	4.0	350	1.0	5.0	2.0	294
1N5919A	SZ305G	5.6	66.9	2.0	250	1.0	5.0	3.0	267
1N5920A	SZ306C	6.2	60.5	2.0	200	1.0	5.0	4.0	241
1N5921A	SZ306I	6.8	55.1	2.5	200	1.0	5.0	5.2	220
1N5922A	SZ307F	7.5	50.0	3.0	400	0.5	5.0	6.0	200
1N5923A	SZ308C	8.2	45.7	3.5	400	0.5	5.0	6.5	182
1N5924A	SZ309B	9.1	41.2	4.0	500	0.5	5.0	7.0	164
1N5925A	SZ3010	10	37.5	4.5	500	0.25	5.0	8.0	150
1N5926A	SZ3011	11	34.1	5.5	550	0.25	1.0	8.4	136
1N5927A	SZ3012	12	31.2	6.5	550	0.25	1.0	9.1	125
1N5928A	SZ3013	13	28.8	7.0	550	0.25	1.0	9.9	115
1N5929A	SZ3015	15	25.0	9.0	600	0.25	1.0	11.4	100
1N5930A	SZ3016	16	23.4	10	600	0.25	1.0	12.2	93
1N5931A	SZ3018	18	20.8	12	650	0.25	1.0	13.7	83
1N5932A	SZ3020	20	18.7	14	650	0.25	1.0	15.2	75
1N5933A	SZ3022	22	17.0	17.5	650	0.25	1.0	16.7	68
1N5934A	SZ3024	24	15.6	19	700	0.25	1.0	18.2	62
1N5935A	SZ3027	27	13.9	23	700	0.25	1.0	20.6	55
1N5936A	SZ3030	30	12.5	26	750	0.25	1.0	22.8	50
1N5937A	SZ3033	33	11.4	33	800	0.25	1.0	25.1	45
1N5938A	SZ3036	36	10.4	38	850	0.25	1.0	27.4	41
1N5939A	SZ3039	39	9.6	45	900	0.25	1.0	29.7	38
1N5940A	SZ3043	43	8.7	53	950	0.25	1.0	32.7	34
1N5941A	SZ3047	47	8.0	67	1000	0.25	1.0	35.8	31
1N5942A	SZ3051	51	7.3	70	1100	0.25	1.0	38.8	29
1N5943A	SZ3056	56	6.7	86	1300	0.25	1.0	42.6	26
1N5944A	SZ3062	62	6.0	100	1500	0.25	1.0	47.1	24
1N5945A	SZ3068	68	5.5	120	1700	0.25	1.0	51.7	22
1N5946A	SZ3075	75	5.0	140	2000	0.25	1.0	56.0	20
1N5947A	SZ3082	82	4.6	160	2500	0.25	1.0	62.2	18
1N5948A	SZ3091	91	4.1	200	3000	0.25	1.0	69.2	16
1N5949A	SZ30B0	100	3.7	250	3100	0.25	1.0	76.0	15
1N5950A	SZ30B1	110	3.4	300	4000	0.25	1.0	83.6	13
1N5951A	SZ30B2	120	3.1	380	4500	0.25	1.0	91.2	12
1N5952A	SZ30B3	130	2.9	450	5000	0.25	1.0	98.8	11
1N5953A	SZ30B5	150	2.5	600	6000	0.25	1.0	114.0	10
1N5954A	SZ30B6	160	2.3	700	6500	0.25	1.0	121.6	9.0
1N5955A	SZ30B8	180	2.1	900	7000	0.25	1.0	136.8	8.0
1N5956A	SZ30D0	200	1.9	1200	8000	0.25	1.0	152.0	7.0

Notes :

- (1) $V_F = 1.5 V_{max}$. @ $I_F = 200mA$
- (2) Suffix "A" is for $\pm 10\%$ tolerance. Use suffix "B" for $\pm 5\%$ tolerance (Axial lead) / replace the fourth digit of type from "0" for $\pm 10\%$ tolerance to "5" for $\pm 5\%$ tolerance (SMD)
- (3) "SZ" for SMD will be omitted on marking of the diode.



Zener Diodes 3 W

The plastic material carries U/L recognition 94V-O.

Type No.	Nominal Zener Voltage		Maximum Zener Impedance			Maximum Reverse Leakage Current		Maximum DC Zener Current
	Vz @ IzT	IzT	ZzT @ IzT	Zzk @ Izk	Izk	IR @ VR	IzM	
Axial Lead	(V)	(mA)	(Ω)	(Ω)	(mA)	(μA)	(V)	(mA)

1SMB5913A Series, 3.0W, Case Type : SMB



1SMB5913A	3.3	113.6	10.0	500	1.0	100	1.0	454
1SMB5914A	3.6	104.2	9.0	500	1.0	75	1.0	416
1SMB5915A	3.9	96.1	7.5	500	1.0	25	1.0	384
1SMB5916A	4.3	87.2	6.0	500	1.0	5.0	1.0	348
1SMB5917A	4.7	79.8	5.0	500	1.0	5.0	1.5	319
1SMB5918A	5.1	73.5	4.0	350	1.0	5.0	2.0	294
1SMB5919A	5.6	66.9	2.0	250	1.0	5.0	3.0	267
1SMB5920A	6.2	60.5	2.0	200	1.0	5.0	4.0	241
1SMB5921A	6.8	55.1	2.5	200	1.0	5.0	5.2	220
1SMB5922A	7.5	50.0	3.0	400	0.5	5.0	6.0	200
1SMB5923A	8.2	45.7	3.5	400	0.5	5.0	6.5	182
1SMB5924A	9.1	41.2	4.0	500	0.5	5.0	7.0	164
1SMB5925A	10	37.5	4.5	500	0.25	5.0	8.0	150
1SMB5926A	11	34.1	5.5	550	0.25	1.0	8.4	136
1SMB5927A	12	31.2	6.5	550	0.25	1.0	9.1	125
1SMB5928A	13	28.8	7.0	550	0.25	1.0	9.9	115
1SMB5929A	15	25.0	9.0	600	0.25	1.0	11.4	100
1SMB5930A	16	23.4	10	600	0.25	1.0	12.2	93
1SMB5931A	18	20.8	12	650	0.25	1.0	13.7	83
1SMB5932A	20	18.7	14	650	0.25	1.0	15.2	75
1SMB5933A	22	17.0	17.5	650	0.25	1.0	16.7	68
1SMB5934A	24	15.6	19	700	0.25	1.0	18.2	62
1SMB5935A	27	13.9	23	700	0.25	1.0	20.6	55
1SMB5936A	30	12.5	26	750	0.25	1.0	22.8	50
1SMB5937A	33	11.4	33	800	0.25	1.0	25.1	45
1SMB5938A	36	10.4	38	850	0.25	1.0	27.4	41
1SMB5939A	39	9.6	45	900	0.25	1.0	29.7	38
1SMB5940A	43	8.7	53	950	0.25	1.0	32.7	34
1SMB5941A	47	8.0	67	1000	0.25	1.0	35.8	31
1SMB5942A	51	7.3	70	1100	0.25	1.0	38.8	29
1SMB5943A	56	6.7	86	1300	0.25	1.0	42.6	26
1SMB5944A	62	6.0	100	1500	0.25	1.0	47.1	24
1SMB5945A	68	5.5	120	1700	0.25	1.0	51.7	22
1SMB5946A	75	5.0	140	2000	0.25	1.0	56.0	20
1SMB5947A	82	4.6	160	2500	0.25	1.0	62.2	18
1SMB5948A	91	4.1	200	3000	0.25	1.0	69.2	16
1SMB5949A	100	3.7	250	3100	0.25	1.0	76.0	15
1SMB5950A	110	3.4	300	4000	0.25	1.0	83.6	13
1SMB5951A	120	3.1	380	4500	0.25	1.0	91.2	12
1SMB5952A	130	2.9	450	5000	0.25	1.0	98.8	11
1SMB5953A	150	2.5	600	6000	0.25	1.0	114.0	10
1SMB5954A	160	2.3	700	6500	0.25	1.0	121.6	9.0
1SMB5955A	180	2.1	900	7000	0.25	1.0	136.8	8.0
1SMB5956A	200	1.9	1200	8000	0.25	1.0	152.0	7.0

Notes :

- (1) $V_F = 1.5 V_{max}$. @ $I_F = 200mA$
- (2) Suffix "A" is for $\pm 10\%$ tolerance. Use suffix "B" for $\pm 5\%$ tolerance.
- (3) "SMB59" for SMD will be omitted on marking of the diode.



Zener Diodes 3 W

The plastic material carries U/L recognition 94V-O.

Type No.		Nominal Zener Voltage		Maximum Zener Impedance			Maximum Reverse Leakage Current		Maximum DC Zener Current
		Vz @ IZT	IZT	ZzT @ IZT	Zzk @ Izk	Izk	IR @ VR	IzM	
Axial Lead	SMD	(V)	(mA)	(Ω)	(Ω)	(mA)	(μA)	(V)	(mA)

3EZ / SZ55 Series, 3.0 W, Case Type : DO-41/SMA

3EZ3.9D5	SZ553J	3.9	192	4.5	400	1.0	80	1.0	630
3EZ4.3D5	SZ554D	4.3	174	4.5	400	1.0	30	1.0	590
3EZ4.7D5	SZ554H	4.7	160	4.0	500	1.0	20	1.0	550
3EZ5.1D5	SZ555B	5.1	147	3.5	550	1.0	5.0	1.0	520
3EZ5.6D5	SZ555G	5.6	134	2.5	600	1.0	5.0	2.0	480
3EZ6.2D5	SZ556C	6.2	121	1.5	700	1.0	5.0	3.0	435
3EZ6.8D5	SZ556I	6.8	110	2.0	700	1.0	50	4.0	393
3EZ7.5D5	SZ557F	7.5	100	2.0	700	0.5	50	5.0	360
3EZ8.2D5	SZ558C	8.2	91	2.3	700	0.5	50	6.0	330
3EZ9.1D5	SZ559B	9.1	82	2.5	700	0.5	50	7.0	297
3EZ10D5	SZ5510	10	75	3.5	700	0.25	50	7.6	270
3EZ11D5	SZ5511	11	68	4.0	700	0.25	50	8.4	225
3EZ12D5	SZ5512	12	63	4.5	700	0.25	1.0	9.1	246
3EZ13D5	SZ5513	13	58	4.5	700	0.25	0.5	9.9	208
3EZ14D5	SZ5514	14	53	5.0	700	0.25	0.5	10.6	193
3EZ15D5	SZ5515	15	50	5.5	700	0.25	0.5	11.4	180
3EZ16D5	SZ5516	16	47	5.5	700	0.25	0.5	12.2	169
3EZ17D5	SZ5517	17	44	6.0	750	0.25	0.5	13.0	159
3EZ18D5	SZ5518	18	42	6.0	750	0.25	0.5	13.7	150
3EZ19D5	SZ5519	19	40	7.0	750	0.25	0.5	14.4	142
3EZ20D5	SZ5520	20	37	7.0	750	0.25	0.5	15.2	135
3EZ22D5	SZ5522	22	34	8.0	750	0.25	0.5	16.7	123
3EZ24D5	SZ5524	24	31	9.0	750	0.25	0.5	18.2	112
3EZ27D5	SZ5527	27	28	10	750	0.25	0.5	20.6	100
3EZ28D5	SZ5528	28	27	12	750	0.25	0.5	21.0	96
3EZ30D5	SZ5530	30	25	16	1000	0.25	0.5	22.5	90
3EZ33D5	SZ5533	33	23	20	1000	0.25	0.5	25.1	82
3EZ36D5	SZ5536	36	21	22	1000	0.25	0.5	27.4	75
3EZ39D5	SZ5539	39	19	28	1000	0.25	0.5	29.7	69
3EZ43D5	SZ5543	43	17	33	1500	0.25	0.5	32.7	63
3EZ47D5	SZ5547	47	16	38	1500	0.25	0.5	35.6	57
3EZ51D5	SZ5551	51	15	45	1500	0.25	0.5	38.8	53
3EZ56D5	SZ5556	56	13	50	2000	0.25	0.5	42.6	48
3EZ62D5	SZ5562	62	12	55	2000	0.25	0.5	47.1	44
3EZ68D5	SZ5568	68	11	70	2000	0.25	0.5	51.7	40
3EZ75D5	SZ5575	75	10	85	2000	0.25	0.5	56.0	36
3EZ82D5	SZ5582	82	9.1	95	3000	0.25	0.5	62.2	33
3EZ91D5	SZ5591	91	8.2	115	3000	0.25	0.5	69.2	30
3EZ100D5	SZ55B0	100	7.5	160	3000	0.25	0.5	76.0	27
3EZ110D5	SZ55B1	110	6.8	225	4000	0.25	0.5	83.6	25
3EZ120D5	SZ55B2	120	6.3	300	4500	0.25	0.5	91.2	22
3EZ130D5	SZ55B3	130	5.8	375	5000	0.25	0.5	98.8	21
3EZ140D5	SZ55B4	140	5.3	475	5000	0.25	0.5	106.4	19
3EZ150D5	SZ55B5	150	5.0	550	6000	0.25	0.5	114.0	18
3EZ160D5	SZ55B6	160	4.7	625	6500	0.25	0.5	121.6	17
3EZ170D5	SZ55B7	170	4.4	650	7000	0.25	0.5	130.4	16
3EZ180D5	SZ55B8	180	4.2	700	7000	0.25	0.5	136.8	15
3EZ190D5	SZ55B9	190	4.0	800	8000	0.25	0.5	144.8	14
3EZ200D5	SZ55D0	200	3.7	875	8000	0.25	0.5	152.0	13

Notes :

- (1) $V_F = 1.5 V_{max}$. @ $I_F = 200mA$.
- (2) Suffix "5" indicates $\pm 5\%$ tolerance, suffix "10" indicates $\pm 10\%$ tolerance (Axial lead) / replace the fourth digit of type from "0" for $\pm 10\%$ tolerance to "5" for $\pm 5\%$ tolerance (SMD)
- (3) " 3EZ" for Axial Lead / "SZ " for SMD will be omitted on marking of the diode



Zener Diodes 3 W

The plastic material carries U/L recognition 94V-O.

Type No.	Working Voltage			Test Current	Differential Resistance		Temperature Coefficient		Maximum Reverse Leakage Current	
	$V_Z @ I_Z$			I_Z	rdiff(Ω) at I_Z		S_Z (%/K) at I_Z		$I_R @ V_R$	
	Min.	Nom.	Max.	(mA)	Typ.	Max.	Min.	Max.	(μ A)	(V)

BZG03-C Series, 3 W, Case Type : SMA



BZG03-C10	9.4	10	10.6	50	2	4	0.05	0.09	7.0	7.5
BZG03-C11	10.4	11	11.6	50	4	7	0.05	0.10	4.0	8.2
BZG03-C12	11.4	12	12.7	50	4	7	0.05	0.10	3.0	9.1
BZG03-C13	12.4	13	14.1	50	5	10	0.05	0.10	2.0	10
BZG03-C15	13.8	15	15.6	50	5	10	0.05	0.10	1.0	11
BZG03-C16	15.3	16	17.1	25	6	15	0.05	0.11	1.0	12
BZG03-C18	16.8	18	19.1	25	6	15	0.06	0.11	1.0	13
BZG03-C20	18.8	20	21.2	25	6	15	0.06	0.11	1.0	15
BZG03-C22	20.8	22	23.3	25	6	15	0.06	0.11	1.0	16
BZG03-C24	22.8	24	25.6	25	7	15	0.06	0.11	1.0	18
BZG03-C27	25.1	27	28.9	25	7	15	0.06	0.11	1.0	20
BZG03-C30	28	30	32	25	8	15	0.06	0.11	1.0	22
BZG03-C33	31	33	35	25	8	15	0.06	0.11	1.0	24
BZG03-C36	34	36	38	10	21	40	0.06	0.11	1.0	27
BZG03-C39	37	39	41	10	21	40	0.06	0.11	1.0	30
BZG03-C43	40	43	46	10	24	45	0.07	0.12	1.0	33
BZG03-C47	44	47	50	10	24	45	0.07	0.12	1.0	36
BZG03-C51	48	51	54	10	25	60	0.07	0.12	1.0	39
BZG03-C56	52	56	60	10	25	60	0.07	0.12	1.0	43
BZG03-C62	58	62	66	10	25	80	0.08	0.13	1.0	47
BZG03-C68	64	68	72	10	25	80	0.08	0.13	1.0	51
BZG03-C75	70	75	79	10	30	100	0.08	0.13	1.0	56
BZG03-C82	77	82	87	10	30	100	0.08	0.13	1.0	62
BZG03-C91	85	91	96	5.0	60	200	0.09	0.13	1.0	68
BZG03-C100	94	100	106	5.0	60	200	0.09	0.13	1.0	75
BZG03-C110	104	110	116	5.0	80	250	0.09	0.13	1.0	82
BZG03-C120	114	120	127	5.0	80	250	0.09	0.13	1.0	91
BZG03-C130	124	130	141	5.0	110	300	0.09	0.13	1.0	100
BZG03-C150	138	150	156	5.0	130	300	0.09	0.13	1.0	110
BZG03-C160	153	160	171	5.0	150	350	0.09	0.13	1.0	120
BZG03-C180	168	180	191	5.0	180	400	0.09	0.13	1.0	130
BZG03-C200	188	200	212	5.0	200	500	0.09	0.13	1.0	150
BZG03-C220	208	220	233	2.0	350	750	0.09	0.13	1.0	160
BZG03-C240	228	240	256	2.0	400	850	0.09	0.13	1.0	180
BZG03-C270	251	270	289	2.0	450	1000	0.09	0.13	1.0	200

Note : (1) "BZG03-" will be omitted in marking on the diode, e.g. p/n BZG03-C10 marking "C10".



Zener Diodes 3 W

The plastic material carries U/L recognition 94V-O.

Type No.	Standoff Voltage		Min. Breakdown Voltage		T _{KVZ} @ I _R		Max. Clamping Voltage		Typical Junction Capacitance
	V _R	I _{R(max)}	V _(BR) @ I _R		(% / K)		V _{CL(R)} @ I _{PP}	@ I _{ZT}	@ V _R = 0 V, f = 1MHz
	V	(μ A)	V	mA	typ	Max	V ⁽¹⁾	A ⁽¹⁾	C _J (pF)

BZG04- Series, 3 W, Case Type : SMA

BZG04-8V2	8.2	20	9.4	50	0.05	0.09	14.8	20.3	1200
BZG04-9V1	9.1	5	10.4	50	0.05	0.10	15.7	19.1	1100
BZG04-10	10	5	11.4	50	0.05	0.10	17.0	17.7	1000
BZG04-11	11	5	12.4	50	0.05	0.10	18.9	15.9	850
BZG04-12	12	5	13.8	50	0.05	0.11	20.9	14.4	815
BZG04-13	13	5	15.3	25	0.06	0.11	22.9	13.1	785
BZG04-15	15	5	16.8	25	0.06	0.11	25.6	11.7	710
BZG04-16	16	5	18.8	25	0.06	0.11	28.4	10.6	655
BZG04-18	18	5	20.8	25	0.06	0.11	31.0	9.7	610
BZG04-20	20	5	22.8	25	0.06	0.11	33.8	8.9	570
BZG04-22	22	5	25.1	25	0.06	0.11	38.1	7.9	545
BZG04-24	24	5	28	25	0.06	0.11	42.2	7.1	505
BZG04-27	27	5	31	25	0.06	0.11	46.2	6.5	475
BZG04-30	30	5	34	10	0.06	0.11	50.1	6.0	450
BZG04-33	33	5	37	10	0.06	0.11	54.1	5.5	420
BZG04-36	36	5	40	10	0.07	0.12	60.7	4.9	390
BZG04-39	39	5	44	10	0.07	0.12	65.5	4.6	370
BZG04-43	43	5	48	10	0.07	0.12	70.8	4.2	350
BZG04-47	47	5	52	10	0.07	0.12	78.6	3.8	330
BZG04-51	51	5	58	10	0.08	0.13	86.5	3.5	310
BZG04-56	56	5	64	10	0.08	0.13	94.4	3.2	291
BZG04-62	62	5	70	10	0.08	0.13	103.5	2.9	280
BZG04-68	68	5	77	10	0.08	0.13	114	2.6	275
BZG04-75	75	5	85	5	0.09	0.13	126	2.4	260
BZG04-82	82	5	94	5	0.09	0.13	139	2.2	250
BZG04-91	91	5	104	5	0.09	0.13	152	2.0	243
BZG04-100	100	5	114	5	0.09	0.13	167	1.8	170
BZG04-110	110	5	124	5	0.09	0.13	185	1.6	153
BZG04-120	120	5	138	5	0.09	0.13	204	1.5	150
BZG04-130	130	5	153	5	0.09	0.13	224	1.3	145
BZG04-150	150	5	168	5	0.09	0.13	249	1.2	140
BZG04-160	160	5	188	5	0.09	0.13	276	1.1	135
BZG04-180	180	5	208	2	0.09	0.13	305	1.0	131
BZG04-200	200	5	228	2	0.09	0.13	336	0.9	122
BZG04-220	220	5	251	2	0.09	0.13	380	0.8	120

Note : (1) "BZG0 - " will be omitted in marking on the diode, e.g. p/n BZG04-8V2 marking "48V2".



Zener Diodes 3 W

The plastic material carries U/L recognition 94V-O.

Type No.	Zener Voltage			Test Current	Maximum Dynamic Resistance		Test Current	Temp. coefficient of Zener Voltage @ I_{ZT}		Maximum Reverse Leakage Current	
	$V_Z @ I_{ZT}$				$r_{zT} @$	$r_{zK} @$		I_{ZK}	(% / K)		$I_R @$
	Min	typ	Max	I_{ZT}	I_{ZK}	I_{ZK}	Min		Max	(μA)	(V)
	(V)	(V)	(V)	(mA)	(Ω)	(Ω)		(mA)			

BZG05C Series, 3 W, Case Type : SMA



BZG05C3V3	3.1	3.3	3.5	80	20	400	1.0	-0.08	0.05	40	1.0
BZG05C3V6	3.4	3.6	3.8	60	20	500	1.0	-0.08	-0.05	20	1.0
BZG05C3V9	3.7	3.9	4.1	60	15	500	1.0	-0.07	-0.02	10	1.0
BZG05C4V3	4.0	4.3	4.6	50	13	500	1.0	-0.07	-0.01	3.0	1.0
BZG05C4V7	4.4	4.7	5.0	45	13	600	1.0	-0.03	0.040	3.0	1.0
BZG05C5V1	4.8	5.1	5.4	45	10	500	1.0	-0.01	0.040	1.0	1.5
BZG05C5V6	5.2	5.6	6.0	45	7.0	400	1.0	0.00	0.045	1.0	2.0
BZG05C6V2	5.8	6.2	6.6	35	4.0	300	1.0	0.010	0.055	1.0	3.0
BZG05C6V8	6.4	6.8	7.2	35	3.5	300	1.0	0.015	0.060	1.0	4.0
BZG05C7V5	7.0	7.5	7.9	35	3.0	200	0.5	0.020	0.065	1.0	4.5
BZG05C8V2	7.7	8.2	8.7	25	5.0	200	0.5	0.030	0.070	1.0	6.2
BZG05C9V1	8.5	9.1	9.6	25	5.0	200	0.5	0.035	0.075	1.0	6.8
BZG05C10	9.4	10	10.6	25	7.0	200	0.5	0.040	0.080	0.5	7.0
BZG05C11	10.4	11	11.6	20	8.0	300	0.5	0.045	0.080	0.5	8.2
BZG05C12	11.4	12	12.7	20	9.0	350	0.5	0.045	0.085	0.5	9.1
BZG05C13	12.4	13	14.1	20	10	400	0.5	0.050	0.085	0.5	10
BZG05C15	13.8	15	15.6	15	15	500	0.5	0.055	0.090	0.5	11
BZG05C16	15.3	16	17.1	15	15	500	0.5	0.055	0.090	0.5	12
BZG05C18	16.8	18	19.1	15	20	500	0.5	0.060	0.090	0.5	13
BZG05C20	18.8	20	21.2	10	24	600	0.5	0.060	0.090	0.5	15
BZG05C22	20.8	22	23.3	10	25	600	0.5	0.060	0.095	0.5	16
BZG05C24	22.8	24	25.6	10	25	600	0.5	0.060	0.095	0.5	18
BZG05C27	25.1	27	28.9	8	30	750	0.25	0.060	0.095	0.5	20
BZG05C30	28	30	32	8	30	1000	0.25	0.060	0.095	0.5	22
BZG05C33	31	33	35	8	35	1000	0.25	0.060	0.095	0.5	24
BZG05C36	34	36	38	8	40	1000	0.25	0.060	0.095	0.5	27
BZG05C39	37	39	41	6	50	1000	0.25	0.060	0.095	0.5	30
BZG05C43	40	43	46	6	50	1000	0.25	0.060	0.095	0.5	33
BZG05C47	44	47	50	4	90	1500	0.25	0.060	0.095	0.5	36
BZG05C51	48	51	54	4	115	1500	0.25	0.060	0.095	0.5	39
BZG05C56	52	56	60	4	120	2000	0.25	0.060	0.095	0.5	43
BZG05C62	58	62	66	4	125	2000	0.25	0.060	0.095	0.5	47
BZG05C68	64	68	72	4	130	2000	0.25	0.060	0.095	0.5	51
BZG05C75	70	75	79	4	135	2000	0.25	0.060	0.095	0.5	56
BZG05C82	77	82	87	2.7	200	3000	0.25	0.060	0.095	0.5	62
BZG05C91	85	91	96	2.7	250	3000	0.25	0.060	0.095	0.5	68
BZG05C100	95	100	106	2.7	350	3000	0.25	0.060	0.095	0.5	75

Note : (1) "BZG0 C " will be omitted in marking on the diode, e.g. p/n BZG05C3V3 marking "53V3".

Zener Diodes 5 W

The plastic material carries U/L recognition 94V-O.

Type No.		Nominal Zener Voltage		Maximum Zener Impedance			Maximum Reverse Leakage Current		Maximum DC. Zener Current
		Vz @ IZT	IZT	ZZT @ IZT	Zzk @ Izk	Izk	IR @ VR	IZM	
Axial Lead	SMD	(V)	(mA)	(Ω)	(Ω)	(mA)	(μA)	(V)	(mA)

1N5333A/SZ60 Series, 5 W, Case Type : D2A/SMB



1N5333A	SZ603D	3.3	380	3.0	400	1.0	300	1.0	1440
1N5334A	SZ603G	3.6	350	2.5	500	1.0	150	1.0	1320
1N5335A	SZ603J	3.9	320	2.0	500	1.0	50	1.0	1220
1N5336A	SZ604D	4.3	290	2.0	500	1.0	10	1.0	1100
1N5337A	SZ604H	4.7	260	2.0	450	1.0	5.0	1.0	1010
1N5338A	SZ605B	5.1	240	1.5	400	1.0	1.0	1.0	930
1N5339A	SZ605G	5.6	220	1.0	400	1.0	1.0	2.0	856
1N5340A	SZ606A	6.0	200	1.0	300	1.0	1.0	3.0	790
1N5341A	SZ606C	6.2	200	1.0	200	1.0	1.0	4.0	765
1N5342A	SZ606I	6.8	175	1.0	200	1.0	150	4.9	700
1N5343A	SZ607F	7.5	175	1.5	200	1.0	150	5.4	630
1N5344A	SZ608C	8.2	150	1.5	200	1.0	150	5.9	580
1N5345A	SZ608H	8.7	150	2.0	200	1.0	150	6.3	545
1N5346A	SZ609B	9.1	150	2.0	150	1.0	150	6.6	520
1N5347A	SZ6010	10	125	2.0	125	1.0	150	7.2	475
1N5348A	SZ6011	11	125	2.5	125	1.0	150	8.0	430
1N5349A	SZ6012	12	100	2.5	125	1.0	2.0	8.6	395
1N5350A	SZ6013	13	100	2.5	100	1.0	1.0	9.4	365
1N5351A	SZ6014	14	100	2.5	75	1.0	1.0	10.1	340
1N5352A	SZ6015	15	75	2.5	75	1.0	1.0	10.8	315
1N5353A	SZ6016	16	75	2.5	75	1.0	1.0	11.5	295
1N5354A	SZ6017	17	70	2.5	75	1.0	0.5	12.2	280
1N5355A	SZ6018	18	65	2.5	75	1.0	0.5	13.0	265
1N5356A	SZ6019	19	65	8.0	75	1.0	0.5	13.7	250
1N5357A	SZ6020	20	65	3.0	75	1.0	0.5	14.4	237
1N5358A	SZ6022	22	50	3.5	75	1.0	0.5	15.8	216
1N5359A	SZ6024	24	50	3.5	100	1.0	0.5	17.3	198
1N5360A	SZ6025	25	50	4.0	110	1.0	0.5	18.0	190
1N5361A	SZ6027	27	50	5.0	120	1.0	0.5	19.4	176
1N5362A	SZ6028	28	50	6.0	130	1.0	0.5	20.1	170
1N5363A	SZ6030	30	40	8.0	140	1.0	0.5	21.6	158
1N5364A	SZ6033	33	40	10	150	1.0	0.5	23.8	144
1N5365A	SZ6036	36	30	11	160	1.0	0.5	25.9	132
1N5366A	SZ6039	39	30	14	170	1.0	0.5	28.1	122
1N5367A	SZ6043	43	30	20	190	1.0	0.5	31.0	110
1N5368A	SZ6047	47	25	25	210	1.0	0.5	33.8	100
1N5369A	SZ6051	51	25	27	230	1.0	0.5	36.7	93.0
1N5370A	SZ6056	56	20	35	280	1.0	0.5	40.3	86.0
1N5371A	SZ6060	60	20	40	350	1.0	0.5	43.0	79.0
1N5372A	SZ6062	62	20	42	400	1.0	0.5	44.6	76.0
1N5373A	SZ6068	68	20	44	500	1.0	0.5	49.0	70.0
1N5374A	SZ6075	75	20	45	620	1.0	0.5	54.0	63.0
1N5375A	SZ6082	82	15	65	720	1.0	0.5	59.0	58.0
1N5376A	SZ6087	87	15	75	760	1.0	0.5	63.0	54.5
1N5377A	SZ6091	91	15	75	760	1.0	0.5	65.5	52.5
1N5378A	SZ60B0	100	12	90	800	1.0	0.5	72.0	47.5
1N5379A	SZ60B1	110	12	125	1000	1.0	0.5	79.2	43.0
1N5380A	SZ60B2	120	10	170	1150	1.0	0.5	86.4	39.5
1N5381A	SZ60B3	130	10	190	1250	1.0	0.5	93.2	36.6
1N5382A	SZ60B4	140	8.0	230	1500	1.0	0.5	101	34.0
1N5383A	SZ60B5	150	8.0	330	1500	1.0	0.5	108	31.6
1N5384A	SZ60B6	160	8.0	350	1650	1.0	0.5	115	29.4
1N5385A	SZ60B7	170	8.0	380	1750	1.0	0.5	122	28.0
1N5386A	SZ60B8	180	5.0	430	1750	1.0	0.5	130	26.4
1N5387A	SZ60B9	190	5.0	450	1850	1.0	0.5	137	25.0
1N5388A	SZ60D0	200	5.0	480	1850	1.0	0.5	144	23.6

Notes :

- (1) $V_F = 1.2 V_{max}$. @ $I_F = 1 A$
- (2) Use suffix "A" for $\pm 10\%$ tolerance and suffix "B" for $\pm 5\%$ tolerance (Axial lead) / replace the fourth digit of type from "0" for $\pm 10\%$ tolerance to "5" for $\pm 5\%$ tolerance (SMD)
- (3) "SZ" for SMD will be omitted on marking of the diode



Zener Diodes 5 W

The plastic material carries U/L recognition 94V-O.

Type No.	Nominal Zener Voltage	Test Current	Maximum Zener Impedance			Maximum Reverse Leakage Current			Maximum DC Zener Current
	$V_Z @ I_{ZT}$	I_{ZT}	$Z_{ZT} @ I_{ZT}$	$Z_{ZK} @ I_{ZK}$	I_{ZK}	$I_R @ V_R (V)$		I_{ZM}	
	(V)	(mA)	(Ω)	(Ω)	(mA)	(μA)	Suffix "A"	Suffix "B"	(mA)

SMBJ5333A Series, 5 W, Case Type : SMB



SMBJ5333A	3.3	380	3.0	400	1.0	300	1.0	1.0	1440
SMBJ5334A	3.6	350	2.5	500	1.0	150	1.0	1.0	1320
SMBJ5335A	3.9	320	2.0	500	1.0	50	1.0	1.0	1220
SMBJ5336A	4.3	290	2.0	500	1.0	10	1.0	1.0	1100
SMBJ5337A	4.7	260	2.0	450	1.0	5.0	1.0	1.0	1010
SMBJ5338A	5.1	240	1.5	400	1.0	1.0	1.0	1.0	930
SMBJ5339A	5.6	220	1.0	400	1.0	1.0	2.0	2.0	856
SMBJ5340A	6.0	200	1.0	300	1.0	1.0	3.0	3.0	790
SMBJ5341A	6.2	200	1.0	200	1.0	1.0	3.0	3.0	765
SMBJ5342A	6.8	175	1.0	200	1.0	10	4.9	5.2	700
SMBJ5343A	7.5	175	1.0	200	1.0	10	5.4	5.7	630
SMBJ5344A	8.2	150	1.0	200	1.0	10	5.9	6.2	580
SMBJ5345A	8.7	150	1.0	200	1.0	10	6.25	6.6	545
SMBJ5346A	9.1	150	2.0	150	1.0	7.5	6.6	6.9	520
SMBJ5347A	10	125	2.0	125	1.0	5.0	7.2	7.6	475
SMBJ5348A	11	125	2.0	125	1.0	5.0	8.0	8.4	430
SMBJ5349A	12	100	2.5	125	1.0	2.0	8.6	9.1	395
SMBJ5350A	13	100	2.5	100	1.0	1.0	9.4	9.9	365
SMBJ5351A	14	100	2.5	75	1.0	1.0	10.1	10.6	340
SMBJ5352A	15	75	2.5	75	1.0	1.0	10.8	11.5	315
SMBJ5353A	16	75	2.5	75	1.0	1.0	11.5	12.2	295
SMBJ5354A	17	70	2.5	75	1.0	0.5	12.2	12.9	280
SMBJ5355A	18	65	2.5	75	1.0	0.5	13.0	13.7	265
SMBJ5356A	19	65	3.0	75	1.0	0.5	13.7	14.4	250
SMBJ5357A	20	65	3.0	75	1.0	0.5	14.4	15.2	237
SMBJ5358A	22	50	3.5	75	1.0	0.5	15.8	16.7	216
SMBJ5359A	24	50	3.5	100	1.0	0.5	17.3	18.2	198
SMBJ5360A	25	50	4.0	110	1.0	0.5	18.0	19.0	190
SMBJ5361A	27	50	5.0	120	1.0	0.5	19.4	20.6	176
SMBJ5362A	28	50	6.0	130	1.0	0.5	20.1	21.2	170
SMBJ5363A	30	40	8.0	140	1.0	0.5	21.6	22.8	158
SMBJ5364A	33	40	10	150	1.0	0.5	23.8	25.1	144
SMBJ5365A	36	30	11	160	1.0	0.5	25.9	27.4	132
SMBJ5366A	39	30	14	170	1.0	0.5	28.1	29.7	122
SMBJ5367A	43	30	20	190	1.0	0.5	31.0	32.7	110
SMBJ5368A	47	25	25	210	1.0	0.5	33.8	35.8	100
SMBJ5369A	51	25	27	230	1.0	0.5	36.7	38.8	93.0
SMBJ5370A	56	20	35	280	1.0	0.5	40.3	42.6	86.0
SMBJ5371A	60	20	40	350	1.0	0.5	43.0	45.5	79.0
SMBJ5372A	62	20	42	400	1.0	0.5	44.6	47.1	76.0
SMBJ5373A	68	20	44	500	1.0	0.5	49.0	51.7	70.0
SMBJ5374A	75	20	45	620	1.0	0.5	54.0	56.0	63.0
SMBJ5375A	82	15	65	720	1.0	0.5	59.0	62.2	58.0
SMBJ5376A	87	15	75	760	1.0	0.5	63.0	66.0	54.5
SMBJ5377A	91	15	75	760	1.0	0.5	65.5	69.2	52.5
SMBJ5378A	100	12	90	800	1.0	0.5	72.0	76.0	47.5
SMBJ5379A	110	12	125	1000	1.0	0.5	79.2	83.6	43.0
SMBJ5380A	120	10	170	1150	1.0	0.5	86.4	91.2	39.5
SMBJ5381A	130	10	190	1250	1.0	0.5	93.2	98.8	36.6
SMBJ5382A	140	8.0	230	1500	1.0	0.5	101	106	34.0
SMBJ5383A	150	8.0	330	1500	1.0	0.5	108	114	31.6
SMBJ5384A	160	8.0	350	1650	1.0	0.5	115	122	29.4
SMBJ5385A	170	8.0	380	1750	1.0	0.5	122	129	28.0
SMBJ5386A	180	5.0	430	1750	1.0	0.5	130	137	26.4
SMBJ5387A	190	5.0	450	1850	1.0	0.5	137	144	25.0
SMBJ5388A	200	5.0	480	1850	1.0	0.5	144	152	23.6

Note : Suffix "A" indicates $\pm 10\%$ tolerance, change to suffix "B" for $\pm 5\%$ tolerance. "SMBJ53" will be omitted on marking of the diode.



Transient Voltage Suppressor Diodes

The plastic material carries U/L recognition 94V-O.

Type No.	Working Peak Reverse Voltage ⁽¹⁾	Breakdown Voltage @ I_T			Test Current	Max. Reverse Leakage Current	Max. Clamping Voltage at I_{PP}	Max. Reverse Peak Pulse Current ⁽³⁾
	V_{RWM}	$V_{BR} @ I_T$			I_T	$I_R @ V_{RWM}$	V_C	I_{PP}
	(V)	Min	Nom	Max.	(mA)	(μ A)	(V)	(mA)

SMF5.0A Series, 200W, Case Type: SOD-123FL



SMF5.0A	5.0	6.40	6.70	7.00	10	400	9.2	21.7
SMF6.0A	6.0	6.67	7.02	7.37	10	400	10.3	19.4
SMF6.5A	6.5	7.22	7.60	7.98	10	250	11.2	17.9
SMF7.0A	7.0	7.78	8.20	8.60	10	100	12.0	16.7
SMF7.5A	7.5	8.33	8.77	9.21	1.0	50	12.9	15.5
SMF8.0A	8.0	8.89	9.36	9.83	1.0	25	13.6	14.7
SMF8.5A	8.5	9.44	9.92	10.4	1.0	10	14.4	13.9
SMF9.0A	9.0	10.0	10.55	11.1	1.0	5.0	15.4	13.0
SMF10A	10	11.1	11.70	12.3	1.0	2.5	17.0	11.8
SMF11A	11	12.2	12.85	13.5	1.0	2.5	18.2	11.0
SMF12A	12	13.3	14.00	14.7	1.0	2.5	19.9	10.1
SMF13A	13	14.4	15.15	15.9	1.0	1.0	21.5	9.3
SMF14A	14	15.6	16.40	17.2	1.0	1.0	23.2	8.6
SMF15A	15	16.7	17.60	18.5	1.0	1.0	24.4	8.2
SMF16A	16	17.8	18.75	19.7	1.0	1.0	26.0	7.7
SMF17A	17	18.9	19.90	20.9	1.0	1.0	27.6	7.2
SMF18A	18	20.0	21.00	22.1	1.0	1.0	29.2	6.8
SMF20A	20	22.2	23.35	24.5	1.0	1.0	32.4	6.2
SMF22A	22	24.4	25.60	26.9	1.0	1.0	35.5	5.6
SMF24A	24	26.7	28.10	29.5	1.0	1.0	38.9	5.1
SMF26A	26	28.9	30.40	31.9	1.0	1.0	42.1	4.8
SMF28A	28	31.1	32.80	34.4	1.0	1.0	45.4	4.4
SMF30A	30	33.3	35.10	36.8	1.0	1.0	48.4	4.1
SMF33A	33	36.7	38.70	40.6	1.0	1.0	53.3	3.8
SMF36A	36	40.0	42.10	44.2	1.0	1.0	58.1	3.4
SMF40A	40	44.4	46.80	49.1	1.0	1.0	64.5	3.1
SMF43A	43	47.8	50.30	52.8	1.0	1.0	69.4	2.9
SMF45A	45	50.0	52.65	55.3	1.0	1.0	72.7	2.8
SMF48A	48	53.3	56.10	58.9	1.0	1.0	77.4	2.6
SMF51A	51	56.7	59.70	62.7	1.0	1.0	82.4	2.4
SMF54A	54	60.0	63.15	66.3	1.0	1.0	87.1	2.3
SMF58A	58	64.4	67.80	71.2	1.0	1.0	93.6	2.1
SMF60A	60	66.7	70.20	73.7	1.0	1.0	96.8	1.8
SMF64A	64	71.1	74.85	78.6	1.0	1.0	103	1.7
SMF70A	70	77.8	81.90	86.0	1.0	1.0	113	1.5
SMF75A	75	83.3	87.70	92.1	1.0	1.0	121	1.4
SMF78A	78	86.7	91.25	95.8	1.0	1.0	126	1.4
SMF85A	85	94.4	99.20	104	1.0	1.0	137	1.3
SMF90A	90	100	105.50	111	1.0	1.0	146	1.2
SMF100A	100	111	117.00	123	1.0	1.0	162	1.1
SMF110A	110	122	128.50	135	1.0	1.0	177	1.0
SMF120A	120	133	140.00	147	1.0	1.0	193	0.9
SMF130A	130	144	151.50	159	1.0	1.0	209	0.8
SMF150A	150	167	176.00	185	1.0	1.0	243	0.7
SMF160A	160	178	187.50	197	1.0	1.0	259	0.7
SMF170A	170	189	199.00	209	1.0	1.0	275	0.6

Note : (1) A transient suppressor is normally selected according to the Working Peak Reverse Voltage (V_{RWM}) which should be equal to or greater than the DC or continuous peak operating voltage level.



Transient Voltage Suppressor Diodes

The plastic material carries U/L recognition 94V-O.

Type No.		Breakdown Voltage @ It (Note 1)			Working Peak Reverse Voltage	Maximum Reverse Leakage @ VRWM	Maximum Reverse Current	Maximum Clamping Voltage @ IRSM	Maximum Temperature Coefficient of VBR (% / °C)
Unidirectional Axial Lead	SMD	VBR (V) Min.	Max.	It (mA)	VRWM (V)	IR (µA)	IRSM (A)	VRSM (V)	

BZW04 / STUB Series, 400W, Case Type: DO-41/SMA

BZW04P5V8	STUB06I	6.45	7.48	10	5.80	1000	38.0	10.5	0.057
BZW04-5V8	STUB56I	6.45	7.14	10	5.80	1000	38.0	10.5	0.057
BZW04P6V4	STUB07F	7.13	8.25	10	6.40	500	35.4	11.3	0.061
BZW04-6V4	STUB57F	7.13	7.88	10	6.40	500	35.4	11.3	0.061
BZW04P7V0	STUB08C	7.79	9.02	10	7.02	200	33.0	12.1	0.065
BZW04-7V0	STUB58C	7.79	8.61	10	7.02	200	33.0	12.1	0.065
BZW04P7V8	STUB09B	8.65	10.0	1.0	7.78	50	30.0	13.4	0.068
BZW04-7V8	STUB59B	8.65	9.55	1.0	7.78	50	30.0	13.4	0.068
BZW04P8V5	STUB010	9.50	11.0	1.0	8.55	10	27.6	14.5	0.073
BZW04-8V5	STUB510	9.50	10.5	1.0	8.55	10	27.6	14.5	0.073
BZW04P9V4	STUB011	10.5	12.1	1.0	9.40	5.0	25.7	15.6	0.075
BZW04-9V4	STUB511	10.5	11.6	1.0	9.40	5.0	25.7	15.6	0.075
BZW04P10	STUB012	11.4	13.2	1.0	10.2	5.0	24.0	16.7	0.078
BZW04-10	STUB512	11.4	12.6	1.0	10.2	5.0	24.0	16.7	0.078
BZW04P11	STUB013	12.4	14.3	1.0	11.1	5.0	22.0	18.2	0.081
BZW04-11	STUB513	12.4	13.7	1.0	11.1	5.0	22.0	18.2	0.081
BZW04P13	STUB015	14.3	16.5	1.0	12.8	5.0	19.0	21.2	0.084
BZW04-13	STUB515	14.3	15.8	1.0	12.8	5.0	19.0	21.2	0.084
BZW04P14	STUB016	15.2	17.6	1.0	13.6	5.0	17.8	22.5	0.086
BZW04-14	STUB516	15.2	16.8	1.0	13.6	5.0	17.8	22.5	0.086
BZW04P15	STUB018	17.1	19.8	1.0	15.3	5.0	16.0	25.2	0.088
BZW04-15	STUB518	17.1	18.9	1.0	15.3	5.0	16.0	25.2	0.088
BZW04P17	STUB020	19.0	22.0	1.0	17.1	5.0	14.5	27.7	0.090
BZW04-17	STUB520	19.0	21.0	1.0	17.1	5.0	14.5	27.7	0.090
BZW04P19	STUB022	20.9	24.2	1.0	18.8	5.0	13.0	30.6	0.092
BZW04-19	STUB522	20.9	23.1	1.0	18.8	5.0	13.0	30.6	0.092
BZW04P20	STUB024	22.8	26.4	1.0	20.5	5.0	12.0	33.2	0.094
BZW04-20	STUB524	22.8	25.2	1.0	20.5	5.0	12.0	33.2	0.094
BZW04P23	STUB027	25.7	29.7	1.0	23.1	5.0	10.7	37.5	0.096
BZW04-23	STUB527	25.7	28.4	1.0	23.1	5.0	10.7	37.5	0.096
BZW04P26	STUB030	28.5	33.0	1.0	25.6	5.0	9.6	41.5	0.097
BZW04-26	STUB530	28.5	31.5	1.0	25.6	5.0	9.6	41.5	0.097
BZW04P28	STUB033	31.4	36.3	1.0	28.2	5.0	8.8	45.7	0.098
BZW04-28	STUB533	31.4	34.7	1.0	28.2	5.0	8.8	45.7	0.098
BZW04P31	STUB036	34.2	39.6	1.0	30.8	5.0	8.0	49.9	0.099
BZW04-31	STUB536	34.2	37.8	1.0	30.8	5.0	8.0	49.9	0.099
BZW04P33	STUB039	37.1	42.9	1.0	33.3	5.0	7.4	53.9	0.100
BZW04-33	STUB539	37.1	41.0	1.0	33.3	5.0	7.4	53.9	0.100
BZW04P37	STUB043	40.9	47.3	1.0	36.8	5.0	6.7	59.3	0.101
BZW04-37	STUB543	40.9	45.2	1.0	36.8	5.0	6.7	59.3	0.101
BZW04P40	STUB047	44.7	51.7	1.0	40.2	5.0	6.2	64.8	0.101
BZW04-40	STUB547	44.7	49.4	1.0	40.2	5.0	6.2	64.8	0.101
BZW04P44	STUB051	48.5	56.1	1.0	43.6	5.0	5.7	70.1	0.102
BZW04-44	STUB551	48.5	53.6	1.0	43.6	5.0	5.7	70.1	0.102
BZW04P48	STUB056	53.2	61.6	1.0	47.8	5.0	5.2	77.0	0.103
BZW04-48	STUB556	53.2	58.8	1.0	47.8	5.0	5.2	77.0	0.103
BZW04P53	STUB062	58.9	68.2	1.0	53.0	5.0	4.7	85.0	0.104
BZW04-53	STUB562	58.9	65.1	1.0	53.0	5.0	4.7	85.0	0.104
BZW04P58	STUB068	64.6	74.8	1.0	58.1	5.0	4.3	92.0	0.104
BZW04-58	STUB568	64.6	71.4	1.0	58.1	5.0	4.3	92.0	0.104



Transient Voltage Suppressor Diodes

The plastic material carries U/L recognition 94V-O.

Type No.		Breakdown Voltage @ I_t (Note 1)			Working Peak Reverse Voltage	Maximum Reverse Leakage @ V_{RWM}	Maximum Reverse Current	Maximum Clamping Voltage @ I_{RSM}	Maximum Temperature Coefficient of V_{BR} (% / °C)
Unidirectional Axial Lead	SMD	V_{BR} (V) Min.	V_{BR} (V) Max.	I_t (mA)	V_{RWM} (V)	I_{RSM} (A)	V_{RSM} (V)		

BZW04 / STUB Series, 400W, Case Type: DO-41/SMA

BZW04P64	STUB075	71.3	82.5	1.0	64.1	5.0	3.9	103	0.105
BZW04-64	STUB575	71.3	78.8	1.0	64.1	5.0	3.9	103	0.105
BZW04P70	STUB082	77.9	90.2	1.0	70.1	5.0	3.5	113	0.105
BZW04-70	STUB582	77.9	86.1	1.0	70.1	5.0	3.5	113	0.105
BZW04P78	STUB091	86.5	100	1.0	77.8	5.0	3.2	125	0.106
BZW04-78	STUB591	86.5	95.5	1.0	77.8	5.0	3.2	125	0.106
BZW04P85	STUB0B0	95.0	110	1.0	85.5	5.0	2.9	137	0.106
BZW04-85	STUB5B0	95.0	105	1.0	85.5	5.0	2.9	137	0.106
BZW04P94	STUB0B1	105	121	1.0	94.0	5.0	2.6	152	0.107
BZW04-94	STUB5B1	105	116	1.0	94.0	5.0	2.6	152	0.107
BZW04P102	STUB0B2	114	132	1.0	102	5.0	2.4	165	0.107
BZW04-102	STUB5B2	114	126	1.0	102	5.0	2.4	165	0.107
BZW04P111	STUB0B3	124	143	1.0	111	5.0	2.2	179	0.107
BZW04-111	STUB5B3	124	137	1.0	111	5.0	2.2	179	0.107
BZW04P128	STUB0B5	143	165	1.0	128	5.0	2.0	207	0.108
BZW04-128	STUB5B5	143	158	1.0	128	5.0	2.0	207	0.108
BZW04P136	STUB0B6	152	176	1.0	136	5.0	1.8	219	0.108
BZW04-136	STUB5B6	152	168	1.0	136	5.0	1.8	219	0.108
BZW04P145	STUB0B7	161	187	1.0	145	5.0	1.7	234	0.108
BZW04-145	STUB5B7	161	179	1.0	145	5.0	1.7	234	0.108
BZW04P154	STUB0B8	171	198	1.0	154	5.0	1.6	246	0.108
BZW04-154	STUB5B8	171	189	1.0	154	5.0	1.6	246	0.108
BZW04P171	STUB0D0	190	220	1.0	171	5.0	1.5	274	0.108
BZW04-171	STUB5D0	190	210	1.0	171	5.0	1.5	274	0.108
BZW04P188	STUB0D2	209	242	1.0	188	5.0	1.4	301	0.108
BZW04-188	STUB5D2	209	231	1.0	188	5.0	1.4	301	0.108
BZW04P213	STUB0D5	237	275	1.0	213	5.0	1.3	344	0.110
BZW04-213	STUB5D5	237	263	1.0	213	5.0	1.3	344	0.110
BZW04P239	STUB0D8	266	308	1.0	239	5.0	1.3	384	0.110
BZW04-239	STUB5D8	266	294	1.0	239	5.0	1.3	384	0.110
BZW04P256	STUB0E0	285	330	1.0	256	5.0	1.2	414	0.110
BZW04-256	STUB5E0	285	315	1.0	256	5.0	1.2	414	0.110
BZW04P273	STUB0E2	304	352	1.0	273	5.0	1.2	438	0.110
BZW04-273	STUB5E2	304	336	1.0	273	5.0	1.2	438	0.110
BZW04P299	STUB0E5	332	385	1.0	299	5.0	0.9	482	0.110
BZW04-299	STUB5E5	332	368	1.0	299	5.0	0.9	482	0.110
BZW04P342	STUB0G0	380	440	1.0	342	5.0	0.9	548	0.110
BZW04-342	STUB5G0	380	420	1.0	342	5.0	0.9	548	0.110
BZW04P376	STUB0G4	418	484	1.0	376	5.0	0.8	603	0.110
BZW04-376	STUB5G4	418	462	1.0	376	5.0	0.8	603	0.110

Notes:

- (1) V_{BR} measured after I_t applied for 300 μ s, I_t = square wave pulse or equivalent
- (2) $V_F = 3.5 V_{max.}$, $I_F = 25 A$ (6.8 V to 110 V)
 $V_F = 5.0 V_{max.}$, $I_F = 25 A$ (120 V to 400 V) per 1/2 square or equivalent sine wave
 $PW = 8.3 ms$, duty cycle = 4 pulses per minute maximum
- (3) For bidirectional use "B" suffix (Axial Lead) / replace the third digit of type from "U" to "B" (SMD)
- (4) "ZW04" for Axial lead / "STU" or "STB" for SMD will be omitted on marking of the diode
- (5) For bidirectional types having V_R of 10 V and under, the IR limit is doubled



Transient Voltage Suppressor Diodes

The plastic material carries U/L recognition 94V-O.

Type No.		Breakdown Voltage @ It (Note 1)			Working Peak Reverse Voltage	Maximum Reverse Leakage @ VRWM	Maximum Reverse Current	Maximum Clamping Voltage @ IRSM	Maximum Temperature Coefficient of VBR
Unidirectional Axial Lead		VBR (V)		It (mA)	VRWM (V)	IR (μA)	IRSM (A)	VRSM (V)	(% / °C)
	SMD	Min.	Max.						

P4KE / STUP Series, 400W, Case Type: DO-41/SMA



P4KE6.8	STUP06I	6.12	7.48	10	5.50	1000	38.0	10.8	0.057
P4KE6.8A	STUP56I	6.45	7.14	10	5.80	1000	40.0	10.5	0.057
P4KE7.5	STUP07F	6.75	8.25	10	6.05	500	36.0	11.7	0.061
P4KE7.5A	STUP57F	7.13	7.88	10	6.40	500	37.0	11.3	0.061
P4KE8.2	STUP08C	7.38	9.02	10	6.63	200	33.0	12.5	0.065
P4KE8.2A	STUP58C	7.79	8.61	10	7.02	200	35.0	12.1	0.065
P4KE9.1	STUP09B	8.19	10.0	1.0	7.37	50	30.0	13.8	0.068
P4KE9.1A	STUP59B	8.65	9.55	1.0	7.78	50	31.0	13.4	0.068
P4KE10	STUP010	9.00	11.0	1.0	8.10	10	28.0	15.0	0.073
P4KE10A	STUP510	9.50	10.5	1.0	8.55	10	29.0	14.5	0.073
P4KE11	STUP011	9.90	12.1	1.0	8.92	5.0	26.0	16.2	0.075
P4KE11A	STUP511	10.5	11.6	1.0	9.40	5.0	27.0	15.6	0.075
P4KE12	STUP012	10.8	13.2	1.0	9.72	5.0	24.0	17.3	0.078
P4KE12A	STUP512	11.4	12.6	1.0	10.2	5.0	25.0	16.7	0.078
P4KE13	STUP013	11.7	14.3	1.0	10.5	5.0	22.0	19.0	0.081
P4KE13A	STUP513	12.4	13.7	1.0	11.1	5.0	23.0	18.2	0.081
P4KE15	STUP015	13.5	16.5	1.0	12.1	5.0	19.0	22.0	0.084
P4KE15A	STUP515	14.3	15.8	1.0	12.8	5.0	20.0	21.2	0.084
P4KE16	STUP016	14.4	17.6	1.0	12.9	5.0	18.0	23.5	0.086
P4KE16A	STUP516	15.2	16.8	1.0	13.6	5.0	19.0	22.5	0.086
P4KE17	STUP017	15.3	18.7	1.0	13.7	5.0	17.0	25.0	0.087
P4KE17A	STUP517	16.2	17.9	1.0	14.5	5.0	18.0	24.0	0.087
P4KE18	STUP018	16.2	19.8	1.0	14.5	5.0	16.0	26.5	0.088
P4KE18A	STUP518	17.1	18.9	1.0	15.3	5.0	17.0	25.5	0.088
P4KE20	STUP020	18.0	22.0	1.0	16.2	5.0	14.0	29.1	0.090
P4KE20A	STUP520	19.0	21.0	1.0	17.1	5.0	15.0	27.7	0.090
P4KE22	STUP022	19.8	24.2	1.0	17.8	5.0	13.0	31.9	0.092
P4KE22A	STUP522	20.9	23.1	1.0	18.8	5.0	14.0	30.6	0.092
P4KE24	STUP024	21.6	26.4	1.0	19.4	5.0	12.0	34.7	0.094
P4KE24A	STUP524	22.8	25.2	1.0	20.5	5.0	13.0	33.2	0.094
P4KE27	STUP027	24.3	29.7	1.0	21.8	5.0	11.0	39.1	0.096
P4KE27A	STUP527	25.7	28.4	1.0	23.1	5.0	11.2	37.5	0.096
P4KE30	STUP030	27.0	33.0	1.0	24.3	5.0	10.0	43.5	0.097
P4KE30A	STUP530	28.5	31.5	1.0	25.6	5.0	10.0	41.4	0.097
P4KE33	STUP033	29.7	36.3	1.0	26.8	5.0	9.0	47.7	0.098
P4KE33A	STUP533	31.4	34.7	1.0	28.2	5.0	9.0	45.7	0.098
P4KE36	STUP036	32.4	39.6	1.0	29.1	5.0	8.0	52.0	0.099
P4KE36A	STUP536	34.2	37.8	1.0	30.8	5.0	8.4	49.9	0.099
P4KE39	STUP039	35.1	42.9	1.0	31.6	5.0	7.4	56.4	0.100
P4KE39A	STUP539	37.1	41.0	1.0	33.3	5.0	7.8	53.9	0.100
P4KE43	STUP043	38.7	47.3	1.0	34.8	5.0	6.8	61.9	0.101
P4KE43A	STUP543	40.9	45.2	1.0	36.8	5.0	7.1	59.3	0.101
P4KE47	STUP047	42.3	51.7	1.0	38.1	5.0	6.2	67.8	0.101
P4KE47A	STUP547	44.7	49.4	1.0	40.2	5.0	6.5	64.8	0.101
P4KE51	STUP051	45.9	56.1	1.0	41.3	5.0	5.7	73.5	0.102
P4KE51A	STUP551	48.5	53.6	1.0	43.6	5.0	6.0	70.1	0.102
P4KE56	STUP056	50.4	61.6	1.0	45.4	5.0	5.2	80.5	0.103
P4KE56A	STUP556	53.2	58.8	1.0	47.8	5.0	5.5	77.0	0.103



Transient Voltage Suppressor Diodes

The plastic material carries U/L recognition 94V-O.

Type No.	Breakdown Voltage @ It (Note 1)		Working Peak Reverse Voltage	Maximum Reverse Leakage @ VRWM	Maximum Reverse Current	Maximum Clamping Voltage @ IRSM	Maximum Temperature Coefficient of VBR
	VBR (V)	It (mA)					
Unidirectional	Min.	Max.					(% / °C)
Axial Lead	SMD						

P4KE / STUP Series, 400W, Case Type: DO-41/SMA



P4KE62	STUP062	55.8	68.2	1.0	50.2	5.0	4.7	89.0	0.104
P4KE62A	STUP562	58.9	65.1	1.0	53.0	5.0	5.0	85.0	0.104
P4KE68	STUP068	61.2	74.8	1.0	55.1	5.0	4.3	98.0	0.104
P4KE68A	STUP568	64.6	71.4	1.0	58.1	5.0	4.6	92.0	0.104
P4KE75	STUP075	67.5	82.5	1.0	60.7	5.0	3.9	108	0.105
P4KE75A	STUP575	71.3	78.8	1.0	64.1	5.0	4.1	103	0.105
P4KE82	STUP082	73.8	90.2	1.0	66.4	5.0	3.6	118	0.105
P4KE82A	STUP582	77.9	86.1	1.0	70.1	5.0	3.7	113	0.105
P4KE91	STUP091	81.9	100	1.0	73.7	5.0	3.2	131	0.106
P4KE91A	STUP591	86.5	95.5	1.0	77.8	5.0	3.4	125	0.106
P4KE100	STUP0B0	90.0	110	1.0	81	5.0	2.9	144	0.106
P4KE100A	STUP5B0	95.0	105	1.0	85.5	5.0	3.1	137	0.106
P4KE110	STUP0B1	99.0	121	1.0	89.2	5.0	2.7	158	0.107
P4KE110A	STUP5B1	105	116	1.0	94.0	5.0	2.8	152	0.107
P4KE120	STUP0B2	108	132	1.0	97.2	5.0	2.4	173	0.107
P4KE120A	STUP5B2	114	126	1.0	102	5.0	2.5	165	0.107
P4KE130	STUP0B3	117	143	1.0	105	5.0	2.2	187	0.107
P4KE130A	STUP5B3	124	137	1.0	111	5.0	2.3	179	0.107
P4KE150	STUP0B5	135	165	1.0	121	5.0	2.0	215	0.108
P4KE150A	STUP5B5	143	158	1.0	128	5.0	2.0	207	0.108
P4KE160	STUP0B6	144	176	1.0	130	5.0	1.8	230	0.108
P4KE160A	STUP5B6	152	168	1.0	136	5.0	1.9	219	0.108
P4KE170	STUP0B7	153	187	1.0	138	5.0	1.7	244	0.108
P4KE170A	STUP5B7	162	179	1.0	145	5.0	1.8	234	0.108
P4KE180	STUP0B8	162	198	1.0	146	5.0	1.6	258	0.108
P4KE180A	STUP5B8	171	189	1.0	154	5.0	1.7	246	0.108
P4KE200	STUP0D0	180	220	1.0	162	5.0	1.5	287	0.108
P4KE200A	STUP5D0	190	210	1.0	171	5.0	1.53	274	0.108
P4KE220	STUP0D2	198	242	1.0	175	5.0	1.16	344	0.108
P4KE220A	STUP5D2	209	231	1.0	185	5.0	1.22	328	0.108
P4KE250	STUP0D5	225	275	1.0	202	5.0	1.11	360	0.110
P4KE250A	STUP5D5	237	263	1.0	214	5.0	1.16	344	0.110
P4KE300	STUP0E0	270	330	1.0	243	5.0	0.93	430	0.110
P4KE300A	STUP5E0	285	315	1.0	256	5.0	0.97	414	0.110
P4KE350	STUP0E5	315	385	1.0	284	5.0	0.79	504	0.110
P4KE350A	STUP5E5	332	368	1.0	300	5.0	0.83	482	0.110
P4KE400	STUP0G0	360	440	1.0	324	5.0	0.70	574	0.110
P4KE400A	STUP5G0	380	420	1.0	342	5.0	0.73	548	0.110
P4KE440	STUP0G4	396	484	1.0	356	5.0	0.95	631	0.110
P4KE440A	STUP5G4	418	462	1.0	376	5.0	1.00	602	0.110

Notes:

- (1) VBR measured after It applied for 300 μs, It = square wave pulse or equivalent
- (2) VF = 3.5 Vmax., IF = 25 A (6.8 V to 91 V)
VF = 5.0 Vmax., IF = 25 A (100 V to 400 V) per 1/2 square or equivalent sine wave
PW = 8.3 ms, duty cycle = 4 pulses per minute maximum
- (3) For bidirectional use "C" or "CA" suffix (Axial Lead) / replace the third letter of type from "U" to "B" (SMD)
- (4) "4KE" for Axial lead / "STU" or "STB" for SMD will be omitted on marking of the diode
- (5) For bidirectional types having VR of 10 V and under, the IR limit is doubled



Transient Voltage Suppressor Diodes

The plastic material carries U/L recognition 94V-O.

Type No.	Breakdown Voltage @ $I_t^{(1)}$		Working Peak Reverse Voltage V_{RWM} (V)	Max. Reverse Leakage @ V_{RWM} $I_R^{(3)}$ (μ A)	Maximum Peak Pulse Surge Current IPPM (A)	Maximum Clamping Voltage @ IPPM V_C (V)
	Min.	Max.				

SMAJ Series, 400W, Case Type: SMA

SMAJ5.0	6.40	7.82	10	5.0	800	41.7	9.6
SMAJ5.0A ⁽⁴⁾	6.40	7.07	10	5.0	800	43.5	9.2
SMAJ6.0	6.67	8.15	10	6.0	800	35.1	11.4
SMAJ6.0A	6.67	7.37	10	6.0	800	38.8	10.3
SMAJ6.5	7.22	8.82	10	6.5	500	32.5	12.3
SMAJ6.5A	7.22	7.98	10	6.5	500	35.7	11.2
SMAJ7.0	7.78	9.51	10	7.0	200	30.1	13.3
SMAJ7.0A	7.78	8.6	10	7.0	200	33.3	12.0
SMAJ7.5	8.33	10.2	1.0	7.5	100	28.0	14.3
SMAJ7.5A	8.33	9.21	1.0	7.5	100	31.0	12.9
SMAJ8.0	8.89	10.9	1.0	8.0	50	26.7	15.0
SMAJ8.0A	8.89	9.83	1.0	8.0	50	29.4	13.6
SMAJ8.5	9.44	11.5	1.0	8.5	10	25.2	15.9
SMAJ8.5A	9.44	10.4	1.0	8.5	10	27.8	14.4
SMAJ9.0	10.0	12.2	1.0	9.0	5.0	23.7	16.9
SMAJ9.0A	10.0	11.1	1.0	9.0	5.0	26.0	15.4
SMAJ10	11.1	13.6	1.0	10	1.0	21.2	18.8
SMAJ10A	11.1	12.3	1.0	10	1.0	23.5	17.0
SMAJ11	12.2	14.9	1.0	11	1.0	19.9	20.1
SMAJ11A	12.2	13.5	1.0	11	1.0	22.0	18.2
SMAJ12	13.3	16.3	1.0	12	1.0	18.2	22.0
SMAJ12A	13.3	14.7	1.0	12	1.0	20.1	19.9
SMAJ13	14.4	17.6	1.0	13	1.0	16.8	23.8
SMAJ13A	14.4	15.9	1.0	13	1.0	18.6	21.5
SMAJ14	15.6	19.1	1.0	14	1.0	15.5	25.8
SMAJ14A	15.6	17.2	1.0	14	1.0	17.2	23.2
SMAJ15	16.7	20.4	1.0	15	1.0	14.8	26.9
SMAJ15A	16.7	18.5	1.0	15	1.0	16.4	24.4
SMAJ16	17.8	21.8	1.0	16	1.0	13.9	28.8
SMAJ16A	17.8	19.7	1.0	16	1.0	15.4	26.0
SMAJ17	18.9	23.1	1.0	17	1.0	13.1	30.5
SMAJ17A	18.9	20.9	1.0	17	1.0	14.5	27.6
SMAJ18	20.0	24.4	1.0	18	1.0	12.4	32.2
SMAJ18A	20.0	22.1	1.0	18	1.0	13.7	29.2
SMAJ20	22.2	27.1	1.0	20	1.0	11.2	35.8
SMAJ20A	22.2	24.5	1.0	20	1.0	12.3	32.4
SMAJ22	24.4	29.8	1.0	22	1.0	10.2	39.4
SMAJ22A	24.4	26.9	1.0	22	1.0	11.3	35.5
SMAJ24	26.7	32.6	1.0	24	1.0	9.3	43.0
SMAJ24A	26.7	29.5	1.0	24	1.0	10.3	38.9
SMAJ26	28.9	35.3	1.0	26	1.0	8.6	46.6
SMAJ26A	28.9	31.9	1.0	26	1.0	9.5	42.1
SMAJ28	31.1	38.0	1.0	28	1.0	8.0	50.0
SMAJ28A	31.1	34.4	1.0	28	1.0	8.8	45.4
SMAJ30	33.3	40.7	1.0	30	1.0	7.5	53.5
SMAJ30A	33.3	36.8	1.0	30	1.0	8.3	48.4
SMAJ33	36.7	44.9	1.0	33	1.0	6.8	59.0
SMAJ33A	36.7	40.6	1.0	33	1.0	7.5	53.3
SMAJ36	40.0	48.9	1.0	36	1.0	6.2	64.3
SMAJ36A	40.0	44.2	1.0	36	1.0	6.9	58.1



Transient Voltage Suppressor Diodes

The plastic material carries U/L recognition 94V-O.

Type No.	Breakdown Voltage @ $I_t^{(1)}$		Working Peak Reverse Voltage V_{RWM} (V)	Max. Reverse Leakage @ V_{RWM} $I_R^{(3)}$ (μ A)	Maximum Peak Pulse Surge Current I_{PPM} (A)	Maximum Clamping Voltage @ I_{PPM} V_C (V)
	Min.	Max.				

SMAJ Series, 400W, Case Type: SMA

SMAJ40	44.4	54.3	1.0	40	1.0	5.6	71.4
SMAJ40A	44.4	49.1	1.0	40	1.0	6.2	64.5
SMAJ43	47.8	58.4	1.0	43	1.0	5.2	76.7
SMAJ43A	47.8	52.8	1.0	43	1.0	5.7	69.4
SMAJ45	50.0	61.1	1.0	45	1.0	5.0	80.3
SMAJ45A	50.0	55.3	1.0	45	1.0	5.5	72.7
SMAJ48	53.3	65.1	1.0	48	1.0	4.7	85.5
SMAJ48A	53.3	58.9	1.0	48	1.0	5.2	77.4
SMAJ51	56.7	69.3	1.0	51	1.0	4.4	91.1
SMAJ51A	56.7	62.7	1.0	51	1.0	4.9	82.4
SMAJ54	60.0	73.3	1.0	54	1.0	4.2	96.3
SMAJ54A	60.0	66.3	1.0	54	1.0	4.6	87.1
SMAJ58	64.4	78.7	1.0	58	1.0	3.9	103
SMAJ58A	64.4	71.2	1.0	58	1.0	4.3	93.6
SMAJ60	66.7	81.5	1.0	60	1.0	3.7	107
SMAJ60A	66.7	73.7	1.0	60	1.0	4.1	96.8
SMAJ64	71.1	86.4	1.0	64	1.0	3.5	114
SMAJ64A	71.1	78.6	1.0	64	1.0	3.9	103
SMAJ70	77.8	95.1	1.0	70	1.0	3.2	125
SMAJ70A	77.8	86	1.0	70	1.0	3.5	113
SMAJ75	83.3	102	1.0	75	1.0	3.0	134
SMAJ75A	83.3	92.1	1.0	75	1.0	3.3	121
SMAJ78	86.7	106	1.0	78	1.0	2.9	139
SMAJ78A	86.7	95.8	1.0	78	1.0	3.2	126
SMAJ85	94.4	115	1.0	85	1.0	2.0	151
SMAJ85A	94.4	104	1.0	85	1.0	2.2	137
SMAJ90	100	122	1.0	90	1.0	1.9	160
SMAJ90A	100	111	1.0	90	1.0	2.1	146
SMAJ100	111	136	1.0	100	1.0	1.7	179
SMAJ100A	111	123	1.0	100	1.0	1.9	162
SMAJ110	122	149	1.0	110	1.0	1.5	196
SMAJ110A	122	135	1.0	110	1.0	1.7	177
SMAJ120	133	163	1.0	120	1.0	1.4	214
SMAJ120A	133	147	1.0	120	1.0	1.6	193
SMAJ130	144	176	1.0	130	1.0	1.3	231
SMAJ130A	144	159	1.0	130	1.0	1.4	209
SMAJ150	167	204	1.0	150	1.0	1.1	268
SMAJ150A	167	185	1.0	150	1.0	1.2	243
SMAJ160	178	218	1.0	160	1.0	1.0	287
SMAJ160A	178	197	1.0	160	1.0	1.2	259
SMAJ170	189	231	1.0	170	1.0	0.99	304
SMAJ170A	189	209	1.0	170	1.0	1.09	275
SMAJ188	209	255	1.0	188	1.0	0.90	344
SMAJ188A	209	231	1.0	188	1.0	0.91	328

Notes :

- (1) Pulse test : $t_p \leq 50ms$
- (2) For bidirectional use "C" or "CA" suffix
- (3) For bi-directional types having V_R of 10 V and less , the I_R limit is doubled
- (4) For the bidirectional SMAJ5.0CA, the maximum V_{BR} is 7.25V
- (5) "SMAJ" will be omitted on marking of the diode



Transient Voltage Suppressor Diodes

The plastic material carries U/L recognition 94V-O.

Type No.		Breakdown Voltage @ It (Note 1)		Working Peak Reverse Voltage	Maximum Reverse Leakage @ VRWM	Maximum Reverse Current	Maximum Clamping Voltage @ IRSM	Maximum Voltage Variation of VBR
Unidirectional Axial Lead		VBR (V)		VRWM	IR	IRSM	VRSM	(mV / °C)
SMD		Min.	Max.	(mA)	(V)	(μA)	(A)	(V)

SA / STUS Series, 500W, Case Type: DO-41/SMA

SA5.0	STUS06H	6.40	7.3	10	5.0	600	52.0	9.6	5.0
SA5.0A	STUS56H	6.40	7.0	10	5.0	600	54.3	9.2	5.0
SA6.0	STUS07A	6.67	8.15	10	6.0	600	43.9	11.4	5.0
SA6.0A	STUS57A	6.67	7.37	10	6.0	600	48.5	10.3	5.0
SA6.5	STUS07G	7.22	8.82	10	6.5	400	40.7	12.3	5.0
SA6.5A	STUS57G	7.22	7.98	10	6.5	400	44.7	11.2	5.0
SA7.0	STUS08C	7.78	9.51	10	7.0	150	37.8	13.3	6.0
SA7.0A	STUS58C	7.78	8.60	10	7.0	150	41.7	12.0	6.0
SA7.5	STUS08I	8.33	10.2	1.0	7.5	50	35.0	14.3	7.0
SA7.5A	STUS58I	8.33	9.21	1.0	7.5	50	38.8	12.9	7.0
SA8.0	STUS09B	8.89	10.9	1.0	8.0	25	33.3	15.0	7.0
SA8.0A	STUS59B	8.89	9.83	1.0	8.0	25	36.7	13.6	7.0
SA8.5	STUS010	9.44	11.5	1.0	8.5	5.0	31.4	15.9	8.0
SA8.5A	STUS510	9.44	10.4	1.0	8.5	5.0	34.7	14.4	8.0
SA9.0	STUS011	10.0	12.2	1.0	9.0	1.0	29.5	16.9	9.0
SA9.0A	STUS511	10.0	11.1	1.0	9.0	1.0	32.5	15.4	9.0
SA10	STUS012	11.1	13.6	1.0	10.0	1.0	26.6	18.8	10.0
SA10A	STUS512	11.1	12.3	1.0	10.0	1.0	29.4	17.0	10.0
SA11	STUS013	12.2	14.9	1.0	11.0	1.0	24.9	20.1	11.0
SA11A	STUS513	12.2	13.5	1.0	11.0	1.0	27.4	18.2	11.0
SA12	STUS014	13.3	16.3	1.0	12.0	1.0	22.7	22.0	12.0
SA12A	STUS514	13.3	14.7	1.0	12.0	1.0	25.1	19.9	12.0
SA13	STUS015	14.4	17.6	1.0	13.0	1.0	21	23.8	13.0
SA13A	STUS515	14.4	15.9	1.0	13.0	1.0	23.2	21.5	13.0
SA14	STUS016	15.6	19.1	1.0	14.0	1.0	19.4	25.8	14.0
SA14A	STUS516	15.6	17.2	1.0	14.0	1.0	21.5	23.2	14.0
SA15	STUS018	16.7	20.4	1.0	15.0	1.0	18.8	26.9	16.0
SA15A	STUS518	16.7	18.5	1.0	15.0	1.0	20.6	24.4	16.0
SA16	STUS019	17.8	21.8	1.0	16.0	1.0	17.6	28.8	19.0
SA16A	STUS519	17.8	19.7	1.0	16.0	1.0	19.2	26.0	17.0
SA17	STUS020	18.9	23.1	1.0	17.0	1.0	16.4	30.5	20.0
SA17A	STUS520	18.9	20.9	1.0	17.0	1.0	18.1	27.6	19.0
SA18	STUS021	20.0	24.4	1.0	18.0	1.0	15.5	32.2	21.0
SA18A	STUS521	20.0	22.1	1.0	18.0	1.0	17.2	29.2	20.0
SA20	STUS023	22.2	27.1	1.0	20.0	1.0	13.9	35.8	25.0
SA20A	STUS523	22.2	24.5	1.0	20.0	1.0	15.4	32.4	23.0
SA22	STUS026	24.4	29.8	1.0	22.0	1.0	12.7	39.4	28.0
SA22A	STUS526	24.4	26.9	1.0	22.0	1.0	14.1	35.5	25.0
SA24	STUS028	26.7	32.6	1.0	24.0	1.0	11.6	43.0	31.0
SA24A	STUS528	26.7	29.5	1.0	24.0	1.0	12.8	38.9	28.0
SA26	STUS030	28.9	35.3	1.0	26.0	1.0	10.7	46.6	31.0
SA26A	STUS530	28.9	31.9	1.0	26.0	1.0	11.9	42.1	30.0
SA28	STUS033	31.1	38.0	1.0	28.0	1.0	9.9	50.0	35.0
SA28A	STUS533	31.1	34.4	1.0	28.0	1.0	11	45.4	31.0
SA30	STUS035	33.3	40.7	1.0	30.0	1.0	9.3	53.5	39.0
SA30A	STUS535	33.3	36.8	1.0	30.0	1.0	10.3	48.4	36.0
SA33	STUS039	36.7	44.9	1.0	33.0	1.0	8.5	59.0	42.0
SA33A	STUS539	36.7	40.6	1.0	33.0	1.0	9.4	53.3	39.0
SA36	STUS042	40.0	48.9	1.0	36.0	1.0	7.8	64.3	46.0
SA36A	STUS542	40.0	44.2	1.0	36.0	1.0	8.6	58.1	41.0



Transient Voltage Suppressor Diodes

The plastic material carries U/L recognition 94V-O.

Type No.		Breakdown Voltage @ It (Note 1)		Working Peak Reverse Voltage	Maximum Reverse Leakage @ VRWM	Maximum Reverse Current	Maximum Clamping Voltage @ IRSM	Maximum Voltage Variation of VBR Temperature
Unidirectional Axial Lead		VBR (V)		VRWM	IR	IRSM	VRSM	(mV / °C)
SMD		Min.	Max.	(mA)	(V)	(μA)	(A)	(V)

SA / STUS Series, 500W, Case Type: DO-41/SMA

SA40	STUS047	44.4	54.3	1.0	40.0	1.0	7.0	71.4	51.0
SA40A	STUS547	44.4	49.1	1.0	40.0	1.0	7.8	64.5	46.0
SA43	STUS050	47.8	58.4	1.0	43.0	1.0	6.5	76.7	55.0
SA43A	STUS550	47.8	52.8	1.0	43.0	1.0	7.2	69.4	50.0
SA45	STUS053	50.0	61.1	1.0	45.0	1.0	6.2	80.3	58.0
SA45A	STUS553	50.0	55.3	1.0	45.0	1.0	6.9	72.7	52.0
SA48	STUS056	53.3	65.1	1.0	48.0	1.0	5.8	85.5	63.0
SA48A	STUS556	53.3	58.9	1.0	48.0	1.0	6.5	77.4	56.0
SA51	STUS060	56.7	69.3	1.0	51.0	1.0	5.5	91.1	66.0
SA51A	STUS560	56.7	62.7	1.0	51.0	1.0	6.1	82.4	61.0
SA54	STUS063	60.0	73.3	1.0	54.0	1.0	5.2	96.3	71.0
SA54A	STUS563	60.0	66.3	1.0	54.0	1.0	5.7	87.1	65.0
SA58	STUS068	64.4	78.7	1.0	58.0	1.0	4.9	103	78.0
SA58A	STUS568	64.4	71.2	1.0	58.0	1.0	5.3	93.6	70.0
SA60	STUS071	66.7	81.5	1.0	60.0	1.0	4.7	107	80.0
SA60A	STUS571	66.7	73.7	1.0	60.0	1.0	5.2	96.8	71.0
SA64	STUS075	71.1	86.9	1.0	64.0	1.0	4.4	114	86.0
SA64A	STUS575	71.1	78.6	1.0	64.0	1.0	4.9	103	76.0
SA70	STUS082	77.8	95.1	1.0	70.0	1.0	4.0	125	94.0
SA70A	STUS582	77.8	86.0	1.0	70.0	1.0	4.4	113	85.0
SA75	STUS088	83.3	102	1.0	75.0	1.0	3.7	134	101
SA75A	STUS588	83.3	92.1	1.0	75.0	1.0	4.1	121	91.0
SA78	STUS091	86.7	106	1.0	78.0	1.0	3.6	139	105
SA78A	STUS591	86.7	95.8	1.0	78.0	1.0	4.0	126	95.0
SA85	STUS099	94.4	115	1.0	85.0	1.0	3.3	151	114
SA85A	STUS599	94.4	104	1.0	85.0	1.0	3.6	137	103
SA90	STUS0B1	100	122	1.0	90.0	1.0	3.1	160	121
SA90A	STUS5B1	100	111	1.0	90.0	1.0	3.4	146	110
SA100	STUS0B2	111	136	1.0	100	1.0	2.8	179	135
SA100A	STUS5B2	111	123	1.0	100	1.0	3.1	162	123
SA110	STUS0B3	122	149	1.0	110	1.0	2.6	196	148
SA110A	STUS5B3	122	135	1.0	110	1.0	2.8	177	133
SA120	STUS0B4	133	163	1.0	120	1.0	2.3	214	162
SA120A	STUS5B4	133	147	1.0	120	1.0	2.0	193	146
SA130	STUS0B5	144	176	1.0	130	1.0	2.2	231	175
SA130A	STUS5B5	144	159	1.0	130	1.0	2.4	209	158
SA150	STUS0B8	167	204	1.0	150	1.0	1.9	268	203
SA150A	STUS5B8	167	185	1.0	150	1.0	2.1	243	184
SA160	STUS0B9	178	218	1.0	160	1.0	1.7	287	217
SA160A	STUS5B9	178	197	1.0	160	1.0	1.9	259	196
SA170	STUS0D0	189	231	1.0	170	1.0	1.6	304	230
SA170A	STUS5D0	189	209	1.0	170	1.0	1.8	275	208

Notes:

- (1) VBR measured after It applied for 300 μs., It = square wave pulse or equivalent
- (2) VF = 3.5 Vmax., IF = 35 A (6.8 V to 91 V)
VF = 5.0 Vmax., IF = 35 A (150 V to 200 V) per 1/2 square or equivalent sine wave
PW = 8.3 ms, duty cycle = 4 pulses per minute maximum
- (3) For bidirectional use suffix "C" or "CA" (Axial Lead) / replace the third digit of type from "U" to "B" (SMD)
- (4) "STU" or "STB" will be omitted on marking of the diode.
- (5) For bidirectional types having VR of 10 V and under, the IR limit is doubled



Transient Voltage Suppressor Diodes

The plastic material carries U/L recognition 94V-O.

Type No.	Breakdown Voltage @ It (Note 1)		Working Peak Reverse Voltage	Maximum Reverse Leakage @ VRWM	Maximum Peak pulse Current	Maximum Clamping Voltage @ IRSM
	VBR (V)					
	Min.	Max.	It (mA)	(V)	(μ A)	(A)
Unidirectional						

BZW06 Series, 600W, Case Type: D2



BZW06P5V8	6.45	7.48	10	5.80	1000	57	10.5
BZW06-5V8	6.45	7.14	10	5.80	1000	57	10.5
BZW06P6V4	7.13	7.25	10	6.40	500	53	11.3
BZW06-6V4	7.13	7.88	10	6.40	500	53	11.3
BZW06P7V0	7.79	9.02	10	7.02	200	50	12.1
BZW06-7V0	7.79	8.61	10	7.02	200	50	12.1
BZW06P7V8	8.65	10.0	1.0	7.78	50	45	13.4
BZW06-7V8	8.65	9.55	1.0	7.78	50	45	13.4
BZW06P8V5	9.50	11.0	1.0	8.55	10	41	14.5
BZW06-8V5	9.50	10.5	1.0	8.55	10	41	14.5
BZW06P9V4	10.5	12.1	1.0	9.40	5.0	38	15.6
BZW06-9V4	10.5	11.6	1.0	9.40	5.0	38	15.6
BZW06P10	11.4	13.2	1.0	10.2	5.0	36	16.7
BZW06-10	11.4	12.6	1.0	10.2	5.0	36	16.7
BZW06P11	12.4	14.3	1.0	11.1	5.0	33	18.2
BZW06-11	12.4	13.7	1.0	11.1	5.0	33	18.2
BZW06P13	14.3	16.5	1.0	12.8	5.0	28	21.2
BZW06-13	14.3	15.8	1.0	12.8	5.0	28	21.2
BZW06P14	15.2	17.6	1.0	13.6	5.0	27	22.5
BZW06-14	15.2	16.8	1.0	13.6	5.0	27	22.5
BZW06P15	17.1	19.8	1.0	15.3	1.0	24	25.2
BZW06-15	17.1	18.9	1.0	15.3	1.0	24	25.2
BZW06P17	19.0	22.0	1.0	17.1	1.0	22	27.2
BZW06-17	19.0	21.0	1.0	17.1	1.0	22	27.2
BZW06P19	20.9	24.2	1.0	18.8	1.0	20	30.6
BZW06-19	20.9	23.1	1.0	18.8	1.0	20	30.6
BZW06P20	22.8	26.4	1.0	20.5	1.0	18	33.2
BZW06-20	22.8	25.2	1.0	20.5	1.0	18	33.2
BZW06P23	25.7	29.7	1.0	23.1	1.0	16	37.5
BZW06-23	25.7	28.4	1.0	23.1	1.0	16	37.5
BZW06P26	28.5	33.0	1.0	25.6	1.0	14.5	41.5
BZW06-26	28.5	31.5	1.0	25.6	1.0	14.5	41.5
BZW06P28	31.4	36.3	1.0	28.2	1.0	13.1	45.7
BZW06-28	31.4	34.7	1.0	28.2	1.0	13.1	45.7
BZW06P31	34.2	39.6	1.0	30.8	1.0	12.0	49.9
BZW06-31	34.2	37.8	1.0	30.8	1.0	12.0	49.9
BZW06P33	37.1	42.9	1.0	33.3	1.0	11.1	53.9
BZW06-33	37.1	41.0	1.0	33.3	1.0	11.1	53.9
BZW06P37	40.9	47.3	1.0	36.8	1.0	10.1	59.3
BZW06-37	40.9	45.2	1.0	36.8	1.0	10.1	59.3
BZW06P40	44.7	51.7	1.0	40.2	1.0	9.3	64.8
BZW06-40	44.7	49.4	1.0	40.2	1.0	9.3	64.8
BZW06P44	48.5	56.1	1.0	43.6	1.0	8.6	70.1
BZW06-44	48.5	53.6	1.0	43.6	1.0	8.6	70.1
BZW06P48	53.2	61.6	1.0	47.8	1.0	7.8	77
BZW06-48	53.2	58.8	1.0	47.8	1.0	7.8	77
BZW06P53	58.9	68.2	1.0	53	1.0	7.1	85
BZW06-53	58.9	65.1	1.0	53	1.0	7.1	85



Transient Voltage Suppressor Diodes

The plastic material carries U/L recognition 94V-O.

Type No.	Breakdown Voltage @ It (Note 1)		Working Peak Reverse Voltage	Maximum Reverse Leakage @ VRWM	Maximum Peak pulse Current	Maximum Clamping Voltage @ IRSM
	VBR (V)		VRWM	IR	IPP	VRSM
	Min.	Max.	(mA)	(V)	(A)	(V)
Unidirectional				(μA)		

BZW06 Series, 600W, Case Type: D2



BZW06P58	64.6	74.8	1.0	58.1	1.0	6.5	92
BZW06-58	64.6	71.4	1.0	58.1	1.0	6.5	92
BZW06P64	71.3	82.5	1.0	64.1	1.0	5.8	103
BZW06-64	71.3	78.8	1.0	64.1	1.0	5.8	103
BZW06P70	77.9	90.2	1.0	70.1	1.0	5.3	113
BZW06-70	77.9	86.1	1.0	70.1	1.0	5.3	113
BZW06P78	86.5	100	1.0	77.8	1.0	4.8	125
BZW06-78	86.5	95.5	1.0	77.8	1.0	4.8	125
BZW06P85	95	110	1.0	85.8	1.0	4.4	137
BZW06-85	95	105	1.0	85.8	1.0	4.4	137
BZW06P94	105	121	1.0	94	1.0	3.9	152
BZW06-94	105	116	1.0	94	1.0	3.9	152
BZW06P102	114	132	1.0	102	1.0	3.6	165
BZW06-102	114	126	1.0	102	1.0	3.6	165
BZW06P111	124	143	1.0	111	1.0	3.4	179
BZW06-111	124	137	1.0	111	1.0	3.4	179
BZW06P128	143	165	1.0	128	1.0	2.9	207
BZW06-128	143	158	1.0	128	1.0	2.9	207
BZW06P136	152	176	1.0	136	1.0	2.7	219
BZW06-136	152	168	1.0	136	1.0	2.7	219
BZW06P145	161	187	1.0	145	1.0	2.6	234
BZW06-145	161	179	1.0	145	1.0	2.6	234
BZW06P154	171	198	1.0	154	1.0	2.4	246
BZW06-154	171	189	1.0	154	1.0	2.4	246
BZW06P171	190	220	1.0	171	1.0	2.2	274
BZW06-171	190	210	1.0	171	1.0	2.2	274
BZW06P188	209	242	1.0	188	1.0	2.0	301
BZW06-188	209	231	1.0	188	1.0	2.0	301
BZW06P213	237	275	1.0	213	1.0	1.8	344
BZW06-213	237	263	1.0	213	1.0	1.8	344
BZW06P239	266	308	1.0	239	1.0	1.7	384
BZW06-239	266	294	1.0	239	1.0	1.7	384
BZW06P256	285	330	1.0	256	1.0	1.6	414
BZW06-256	285	315	1.0	256	1.0	1.6	414
BZW06P273	304	352	1.0	273	1.0	1.6	436
BZW06-273	304	336	1.0	273	1.0	1.6	436
BZW06P299	332	285	1.0	299	1.0	1.6	482
BZW06-299	332	368	1.0	299	1.0	1.6	482
BZW06P342	380	440	1.0	342	1.0	1.3	548
BZW06-342	380	420	1.0	342	1.0	1.3	548
BZW06P376	418	484	1.0	376	1.0	1.3	603
BZW06-376	418	462	1.0	376	1.0	1.3	603

Notes:

- (1) Pulse test : $t_p < 50$ ms
- (2) For Bidirectional use suffix "B" (Axial Lead)
- (3) For bidirectional types having VR of 10 V and under, the IR limit is doubled
- (4) "ZW06" will be omitted on marking of the diode.



Transient Voltage Suppressor Diodes

The plastic material carries U/L recognition 94V-O.

Type No.		Breakdown Voltage @ It (Note 1)		Working Peak Reverse Voltage	Maximum Reverse Leakage @ VRWM	Maximum Reverse Current	Maximum Clamping Voltage @ IRSM	Maximum Temperature Coefficient of VBR	
		VBR (V)	It (mA)						VRWM (V)
Unidirectional	Axial Lead	Min.	Max.	(mA)	(V)	(μA)	(A)	(V)	(% / °C)

P6KE/STU6 Series, 600W, Case Type: D2A/SMB



P6KE6.8	STU606I	6.12	7.48	10	5.50	1000	55.5	10.8	0.057
P6KE6.8A	STU656I	6.45	7.14	10	5.80	1000	57.0	10.5	0.057
P6KE7.5	STU607F	6.75	8.25	10	6.05	500	51.0	11.7	0.061
P6KE7.5A	STU657F	7.13	7.88	10	6.40	500	53.0	11.3	0.061
P6KE8.2	STU608C	7.38	9.02	10	6.63	200	48.0	12.5	0.065
P6KE8.2A	STU658C	7.79	8.61	10	7.02	200	50.0	12.1	0.065
P6KE9.1	STU609B	8.19	10.0	1.0	7.37	50	44.0	13.8	0.068
P6KE9.1A	STU659B	8.65	9.55	1.0	7.78	50	45.0	13.4	0.068
P6KE10	STU6010	9.00	11.0	1.0	8.10	10	40.0	15.0	0.073
P6KE10A	STU6510	9.50	10.5	1.0	8.55	10	41.0	14.5	0.073
P6KE11	STU6011	9.90	12.1	1.0	8.92	5.0	37.0	16.2	0.075
P6KE11A	STU6511	10.5	11.6	1.0	9.40	5.0	38.0	15.6	0.075
P6KE12	STU6012	10.8	13.2	1.0	9.72	5.0	35.0	17.3	0.078
P6KE12A	STU6512	11.4	12.6	1.0	10.2	5.0	36.0	16.7	0.078
P6KE13	STU6013	11.7	14.3	1.0	10.5	5.0	32.0	19.0	0.081
P6KE13A	STU6513	12.4	13.7	1.0	11.1	5.0	33.0	18.2	0.081
P6KE15	STU6015	13.5	16.3	1.0	12.1	5.0	27.0	22.0	0.084
P6KE15A	STU6515	14.3	15.8	1.0	12.8	5.0	28.0	21.2	0.084
P6KE16	STU6016	14.4	17.6	1.0	12.9	5.0	26.0	23.5	0.086
P6KE16A	STU6516	15.2	16.8	1.0	13.6	5.0	27.0	22.5	0.086
P6KE18	STU6018	16.2	19.8	1.0	14.5	5.0	23.0	26.5	0.088
P6KE18A	STU6518	17.1	18.9	1.0	15.3	5.0	24.0	25.2	0.088
P6KE20	STU6020	18.0	22.0	1.0	16.2	5.0	21.0	29.1	0.090
P6KE20A	STU6520	19.0	21.0	1.0	17.1	5.0	22.0	27.7	0.090
P6KE22	STU6022	19.8	24.2	1.0	17.8	5.0	19.0	31.9	0.092
P6KE22A	STU6522	20.9	23.1	1.0	18.8	5.0	20.0	30.6	0.092
P6KE24	STU6024	21.6	26.4	1.0	19.4	5.0	17.0	34.7	0.094
P6KE24A	STU6524	22.8	25.2	1.0	20.5	5.0	18.0	33.2	0.094
P6KE27	STU6027	24.3	29.7	1.0	21.8	5.0	15.0	39.1	0.096
P6KE27A	STU6527	25.7	28.4	1.0	23.1	5.0	16.0	37.5	0.096
P6KE30	STU6030	27.0	33.0	1.0	24.3	5.0	14.0	43.5	0.097
P6KE30A	STU6530	28.5	31.5	1.0	25.6	5.0	14.4	41.4	0.097
P6KE33	STU6033	29.7	36.3	1.0	26.8	5.0	12.6	47.7	0.098
P6KE33A	STU6533	31.4	34.7	1.0	28.2	5.0	13.2	45.7	0.098
P6KE36	STU6036	32.4	39.6	1.0	29.1	5.0	11.6	52.0	0.099
P6KE36A	STU6536	34.2	37.8	1.0	30.8	5.0	12.0	49.9	0.099
P6KE39	STU6039	35.1	42.9	1.0	31.6	5.0	10.6	56.4	0.100
P6KE39A	STU6539	37.1	41.0	1.0	33.3	5.0	11.2	53.9	0.100
P6KE43	STU6043	38.7	47.3	1.0	34.8	5.0	9.6	61.9	0.101
P6KE43A	STU6543	40.9	45.2	1.0	36.8	5.0	10.1	59.3	0.101
P6KE47	STU6047	42.3	51.7	1.0	38.1	5.0	8.9	67.8	0.101
P6KE47A	STU6547	44.7	49.4	1.0	40.2	5.0	9.3	64.8	0.101
P6KE51	STU6051	45.9	56.1	1.0	41.3	5.0	8.2	73.5	0.102
P6KE51A	STU6551	48.5	53.6	1.0	43.6	5.0	8.6	70.1	0.102
P6KE56	STU6056	50.4	61.6	1.0	45.4	5.0	7.4	80.5	0.103
P6KE56A	STU6556	53.2	58.8	1.0	47.8	5.0	7.8	77.0	0.103
P6KE62	STU6062	55.8	68.2	1.0	50.2	5.0	6.8	89.0	0.104
P6KE62A	STU6562	58.9	65.1	1.0	53.0	5.0	7.1	85.0	0.104



Transient Voltage Suppressor Diodes

The plastic material carries U/L recognition 94V-O.

Type No.		Breakdown Voltage @ I_t (Note 1)		Working Peak Reverse Voltage	Maximum Reverse Leakage @ V_{RWM}	Maximum Reverse Current	Maximum Clamping Voltage @ I_{RSM}	Maximum Temperature Coefficient of V_{BR}	
		V_{BR} (V)	I_t (mA)						V_{RWM} (V)
Unidirectional	Axial Lead	Min.	Max.	(mA)	(V)	(μ A)	(A)	(V)	(% / °C)

P6KE/STU6 Series, 600W, Case Type: D2A/SMB



P6KE68	STU6068	61.2	74.8	1.0	55.1	5.0	6.1	98.0	0.104
P6KE68A	STU6568	64.6	71.4	1.0	58.1	5.0	6.5	92.0	0.104
P6KE75	STU6075	67.5	82.5	1.0	60.7	5.0	5.5	108	0.105
P6KE75A	STU6575	71.3	78.8	1.0	64.1	5.0	5.8	103	0.105
P6KE82	STU6082	73.8	90.2	1.0	66.4	5.0	5.1	118	0.105
P6KE82A	STU6582	77.9	86.1	1.0	70.1	5.0	5.3	113	0.105
P6KE91	STU6091	81.9	100	1.0	73.7	5.0	4.5	131	0.106
P6KE91A	STU6591	86.5	95.5	1.0	77.8	5.0	4.8	125	0.106
P6KE100	STU60B0	90.0	110	1.0	81	5.0	4.2	144	0.106
P6KE100A	STU65B0	95.0	105	1.0	85.5	5.0	4.4	137	0.106
P6KE110	STU60B1	99.0	121	1.0	89.2	5.0	3.8	158	0.107
P6KE110A	STU65B1	105	116	1.0	94.0	5.0	4.0	152	0.107
P6KE120	STU60B2	108	132	1.0	97.2	5.0	3.5	173	0.107
P6KE120A	STU65B2	114	126	1.0	102	5.0	3.6	165	0.107
P6KE130	STU60B3	117	143	1.0	106	5.0	3.2	187	0.107
P6KE130A	STU65B3	124	137	1.0	111	5.0	3.3	179	0.107
P6KE150	STU60B5	135	165	1.0	121	5.0	2.8	215	0.108
P6KE150A	STU65B5	143	158	1.0	128	5.0	2.9	207	0.108
P6KE160	STU60B6	144	176	1.0	130	5.0	2.6	230	0.108
P6KE160A	STU65B6	152	168	1.0	136	5.0	2.7	219	0.108
P6KE170	STU60B7	153	187	1.0	138	5.0	2.5	244	0.108
P6KE170A	STU65B7	162	179	1.0	145	5.0	2.6	234	0.108
P6KE180	STU60B8	162	198	1.0	146	5.0	2.3	258	0.108
P6KE180A	STU65B8	171	189	1.0	154	5.0	2.4	246	0.108
P6KE200	STU60D0	180	220	1.0	162	5.0	2.1	287	0.108
P6KE200A	STU65D0	190	210	1.0	171	5.0	2.2	274	0.108
P6KE220	STU60D2	198	242	1.0	175	5.0	1.75	344	0.108
P6KE220A	STU65D2	209	231	1.0	185	5.0	1.83	328	0.108
P6KE250	STU60D5	225	275	1.0	202	5.0	1.67	360	0.110
P6KE250A	STU65D5	237	263	1.0	214	5.0	1.75	344	0.110
P6KE300	STU60E0	270	330	1.0	243	5.0	1.40	430	0.110
P6KE300A	STU65E0	285	315	1.0	256	5.0	1.45	414	0.110
P6KE320	STU60E2	288	352	1.0	259	5.0	1.31	460	0.110
P6KE320A	STU65E2	303	337	1.0	272	5.0	1.35	445	0.110
P6KE350	STU60E5	315	385	1.0	284	5.0	1.20	504	0.110
P6KE350A	STU65E5	332	368	1.0	300	5.0	1.25	482	0.110
P6KE400	STU60G0	360	440	1.0	324	5.0	1.05	574	0.110
P6KE400A	STU65G0	380	420	1.0	342	5.0	1.10	548	0.110
P6KE440	STU60G4	396	484	1.0	356	5.0	0.95	631	0.110
P6KE440A	STU65G4	418	462	1.0	376	5.0	1.00	602	0.110

Notes:

- (1) V_{BR} measured after I_t applied for 300 μ s., I_t = square wave pulse or equivalent
- (2) $V_F = 3.5 V_{max.}$, $I_F = 50 A$ (6.8 V to 91 V)
 $V_F = 5.0 V_{max.}$, $I_F = 50 A$ (100 V to 440 V) per 1/2 square or equivalent sine wave
 $PW = 8.3 ms$, duty cycle = 4 pulses per minute maximum
- (3) For bidirectional use suffix "C" or "CA" (Axial Lead) / replace the third digit of type from "U" to "B" (SMD)
- (4) "6KE" for Axial lead / "STU" or "STB" for SMD will be omitted on marking of the diode
- (5) Add suffix "S" (Axial Lead) for case type D2
- (6) For bidirectional types having V_R of 10 V and under, the I_R limit is doubled



Transient Voltage Suppressor Diodes

The plastic material carries U/L recognition 94V-O.

Type No.	Breakdown Voltage @ I_t (Note 1)		Working Peak Reverse Voltage V_{RWM}	Maximum Reverse Leakage @ V_{RWM} I_R	Maximum Reverse Current I_{RSM}	Maximum Clamping Voltage @ I_{RSM} V_{RSM}	Maximum Temperature Coefficient of V_{BR} (% / °C)
	V_{BR} (V)	I_t (mA)					
Unidirectional	Min.	Max.	(V)	(mA)	(A)	(V)	

P6SMB Series, 600W, Case Type: SMB



P6SMB6.8A	6.45	7.14	10	5.80	1000	57.0	10.5	0.057
P6SMB7.5A	7.13	7.88	10	6.40	500	53.0	11.3	0.061
P6SMB8.2A	7.79	8.61	10	7.02	200	50.0	12.1	0.065
P6SMB9.1A	8.65	9.55	1.0	7.78	50	45.0	13.4	0.068
P6SMB10A	9.50	10.5	1.0	8.55	10	41.0	14.5	0.073
P6SMB11A	10.5	11.6	1.0	9.40	5.0	38.0	15.6	0.075
P6SMB12A	11.4	12.6	1.0	10.2	5.0	36.0	16.7	0.078
P6SMB13A	12.4	13.7	1.0	11.1	5.0	33.0	18.2	0.081
P6SMB15A	14.3	15.8	1.0	12.8	5.0	28.0	21.2	0.084
P6SMB16A	15.2	16.8	1.0	13.6	5.0	27.0	22.5	0.086
P6SMB18A	17.1	18.9	1.0	15.3	5.0	24.0	25.2	0.088
P6SMB20A	19.0	21.0	1.0	17.1	5.0	22.0	27.7	0.090
P6SMB22A	20.9	23.1	1.0	18.8	5.0	20.0	30.6	0.092
P6SMB24A	22.8	25.2	1.0	20.5	5.0	18.0	33.2	0.094
P6SMB27A	25.7	28.4	1.0	23.1	5.0	16.0	37.5	0.096
P6SMB30A	28.5	31.5	1.0	25.6	5.0	14.4	41.4	0.097
P6SMB33A	31.4	34.7	1.0	28.2	5.0	13.2	45.7	0.098
P6SMB36A	34.2	37.8	1.0	30.8	5.0	12.0	49.9	0.099
P6SMB39A	37.1	41.0	1.0	33.3	5.0	11.2	53.9	0.100
P6SMB43A	40.9	45.2	1.0	36.8	5.0	10.1	59.3	0.101
P6SMB47A	44.7	49.4	1.0	40.2	5.0	9.3	64.8	0.101
P6SMB51A	48.5	53.6	1.0	43.6	5.0	8.6	70.1	0.102
P6SMB56A	53.2	58.8	1.0	47.8	5.0	7.8	77.0	0.103
P6SMB62A	58.9	65.1	1.0	53.0	5.0	7.1	85.0	0.104
P6SMB68A	64.6	71.4	1.0	58.1	5.0	6.5	92.0	0.104
P6SMB75A	71.3	78.8	1.0	64.1	5.0	5.8	103	0.105
P6SMB82A	77.9	86.1	1.0	70.1	5.0	5.3	113	0.105
P6SMB91A	86.5	95.5	1.0	77.8	5.0	4.8	125	0.106
P6SMB100A	95.0	105	1.0	85.5	5.0	4.4	137	0.106
P6SMB110A	105	116	1.0	94.0	5.0	4.0	152	0.107
P6SMB120A	114	126	1.0	102	5.0	3.6	165	0.107
P6SMB130A	124	137	1.0	111	5.0	3.3	179	0.107
P6SMB150A	143	158	1.0	128	5.0	2.9	207	0.108
P6SMB160A	152	168	1.0	136	5.0	2.7	219	0.108
P6SMB170A	162	179	1.0	145	5.0	2.6	234	0.108
P6SMB180A	171	189	1.0	154	5.0	2.4	246	0.108
P6SMB200A	190	210	1.0	171	5.0	2.2	274	0.108
P6SMB220A	209	231	1.0	185	5.0	1.83	328	0.108
P6SMB250A	237	263	1.0	214	5.0	1.75	344	0.110
P6SMB300A	285	315	1.0	256	5.0	1.45	414	0.110
P6SMB350A	332	368	1.0	300	5.0	1.25	482	0.110
P6SMB400A	380	420	1.0	342	5.0	1.10	548	0.110
P6SMB440A	418	462	1.0	376	5.0	1.00	602	0.110
P6SMB480A	456	504	1.0	408	5.0	0.91	658	0.110
P6SMB510A	485	535	1.0	434	5.0	0.86	698	0.110
P6SMB540A	513	567	1.0	459	5.0	0.81	740	0.110

Notes:

- (1) V_{BR} measured after I_t applied for 300 μs ., I_t = square wave pulse or equivalent
- (2) $V_F = 3.5 V_{max}$., $I_F = 50 A$ (6.8 V to 91 V)
 $V_F = 5.0 V_{max}$., $I_F = 50 A$ (100 V to 540 V) per 1/2 square or equivalent sine wave
 $PW = 8.3 ms$, duty cycle = 4 pulses per minute maximum
- (3) For bidirectional use suffix "CA" .Bidirectional types having V_R of 10 V and under, the I_R limit is doubled
- (4) "P6SMB" will be omitted in marking on the diode



Transient Voltage Suppressor Diodes

The plastic material carries U/L recognition 94V-O.

Type No.	Breakdown Voltage @ $I_T^{(1)}$			Reverse Stand-off Voltage	Maximum Reverse Leakage @ V_{WM}	Maximum Peak Pulse Surge Current	Maximum Clamping Voltage @ I_{PPM}
	V_{BR} (V)		I_T				
Unidirectional	Min.	Max.	(mA)	(V)	(μ A)	(A)	(V)

SMBJ Series, 600W, Case Type: SMB



SMBJ5.0	6.40	7.82	10	5.0	800	62.5	9.6
SMBJ5.0A	6.40	7.07	10	5.0	800	65.2	9.2
SMBJ6.0	6.67	8.15	10	6.0	800	52.6	11.4
SMBJ6.0A	6.67	7.37	10	6.0	800	58.3	10.3
SMBJ6.5	7.22	8.82	10	6.5	500	48.7	12.3
SMBJ6.5A	7.22	7.98	10	6.5	500	53.6	11.2
SMBJ7.0	7.78	9.51	10	7.0	200	45.1	13.3
SMBJ7.0A	7.78	8.6	10	7.0	200	50.0	12.0
SMBJ7.5	8.33	10.2	1.0	7.5	100	42.0	14.3
SMBJ7.5A	8.33	9.21	1.0	7.5	100	46.5	12.9
SMBJ8.0	8.89	10.9	1.0	8.0	50	40.0	15.0
SMBJ8.0A	8.89	9.83	1.0	8.0	50	44.1	13.6
SMBJ8.5	9.44	11.5	1.0	8.5	20	37.7	15.9
SMBJ8.5A	9.44	10.4	1.0	8.5	20	41.7	14.4
SMBJ9.0	10.0	12.2	1.0	9.0	10	35.5	16.9
SMBJ9.0A	10.0	11.1	1.0	9.0	10	39.0	15.4
SMBJ10	11.1	13.6	1.0	10	5.0	31.9	18.8
SMBJ10A	11.1	12.3	1.0	10	5.0	35.3	17.0
SMBJ11	12.2	14.9	1.0	11	5.0	29.9	20.1
SMBJ11A	12.2	13.5	1.0	11	5.0	33.0	18.2
SMBJ12	13.3	16.3	1.0	12	5.0	27.3	22.0
SMBJ12A	13.3	14.7	1.0	12	5.0	30.2	19.9
SMBJ13	14.4	17.6	1.0	13	5.0	25.2	23.8
SMBJ13A	14.4	15.9	1.0	13	5.0	27.9	21.5
SMBJ14	15.6	19.1	1.0	14	5.0	23.3	25.8
SMBJ14A	15.6	17.2	1.0	14	5.0	25.8	23.2
SMBJ15	16.7	20.4	1.0	15	5.0	22.3	26.9
SMBJ15A	16.7	18.5	1.0	15	5.0	24.0	24.4
SMBJ16	17.8	21.8	1.0	16	5.0	20.8	28.8
SMBJ16A	17.8	19.7	1.0	16	5.0	23.1	26.0
SMBJ17	18.9	23.1	1.0	17	5.0	19.7	30.5
SMBJ17A	18.9	20.9	1.0	17	5.0	21.7	27.6
SMBJ18	20.0	24.4	1.0	18	5.0	18.6	32.2
SMBJ18A	20.0	22.1	1.0	18	5.0	20.5	29.2
SMBJ20	22.2	27.1	1.0	20	5.0	16.7	35.8
SMBJ20A	22.2	24.5	1.0	20	5.0	18.5	32.4
SMBJ22	24.4	29.8	1.0	22	5.0	15.2	39.4
SMBJ22A	24.4	26.9	1.0	22	5.0	16.9	35.5
SMBJ24	26.7	32.6	1.0	24	5.0	14.0	43.0
SMBJ24A	26.7	29.5	1.0	24	5.0	15.4	38.9
SMBJ26	28.9	35.3	1.0	26	5.0	12.4	46.6
SMBJ26A	28.9	31.9	1.0	26	5.0	14.2	42.1
SMBJ28	31.1	38	1.0	28	5.0	12.0	50.0
SMBJ28A	31.1	34.4	1.0	28	5.0	13.2	45.4
SMBJ30	33.3	40.7	1.0	30	5.0	11.2	53.5
SMBJ30A	33.3	36.8	1.0	30	5.0	12.4	48.4
SMBJ33	36.7	44.9	1.0	33	5.0	10.2	59.0
SMBJ33A	36.7	40.6	1.0	33	5.0	11.3	53.3
SMBJ36	40.0	48.9	1.0	36	5.0	9.3	64.3
SMBJ36A	40.0	44.2	1.0	36	5.0	10.3	58.1
SMBJ40	44.4	54.3	1.0	40	5.0	8.4	71.4
SMBJ40A	44.4	49.1	1.0	40	5.0	9.3	64.5



Transient Voltage Suppressor Diodes

The plastic material carries U/L recognition 94V-O.

Type No.	Breakdown Voltage @ I_T ⁽¹⁾			Reverse Stand-off Voltage	Maximum Reverse Leakage @ V_{WM}	Maximum Peak Pulse Surge Current	Maximum Clamping Voltage @ I_{PPM}
	V_{BR} (V)		I_T				
Unidirectional	Min.	Max.	(mA)	(V)	(μ A)	(A)	(V)

SMBJ Series, 600W, Case Type: SMB



SMBJ43	47.8	58.4	1.0	43	5.0	7.8	76.7
SMBJ43A	47.8	52.8	1.0	43	5.0	8.6	69.4
SMBJ45	50.0	61.1	1.0	45	5.0	7.5	80.3
SMBJ45A	50.0	55.3	1.0	45	5.0	8.3	72.7
SMBJ48	53.3	65.1	1.0	48	5.0	7.0	85.5
SMBJ48A	53.3	58.9	1.0	48	5.0	7.7	77.4
SMBJ51	56.7	69.3	1.0	51	5.0	6.6	91.1
SMBJ51A	56.7	62.7	1.0	51	5.0	7.3	82.4
SMBJ54	60.0	73.3	1.0	54	5.0	6.2	96.3
SMBJ54A	60.0	66.3	1.0	54	5.0	6.9	87.1
SMBJ58	64.4	78.7	1.0	58	5.0	5.8	103
SMBJ58A	64.4	71.2	1.0	58	5.0	6.4	93.6
SMBJ60	66.7	81.5	1.0	60	5.0	5.6	107
SMBJ60A	66.7	73.7	1.0	60	5.0	6.2	96.8
SMBJ64	71.1	86.9	1.0	64	5.0	5.3	114
SMBJ64A	71.1	78.6	1.0	64	5.0	5.8	103
SMBJ70	77.8	95.1	1.0	70	5.0	4.8	125
SMBJ70A	77.8	86.0	1.0	70	5.0	5.3	113
SMBJ75	83.3	102	1.0	75	5.0	4.5	134
SMBJ75A	83.3	92.1	1.0	75	5.0	4.9	121
SMBJ78	86.7	106	1.0	78	5.0	4.3	139
SMBJ78A	86.7	95.8	1.0	78	5.0	4.7	126
SMBJ85	94.4	115	1.0	85	5.0	3.9	151
SMBJ85A	94.4	104	1.0	85	5.0	4.4	137
SMBJ90	100	122	1.0	90	5.0	3.8	160
SMBJ90A	100	111	1.0	90	5.0	4.1	146
SMBJ100	111	136	1.0	100	5.0	3.4	179
SMBJ100A	111	123	1.0	100	5.0	3.7	162
SMBJ110	122	149	1.0	110	5.0	3.0	196
SMBJ110A	122	135	1.0	110	5.0	3.4	177
SMBJ120	133	163	1.0	120	5.0	2.8	214
SMBJ120A	133	147	1.0	120	5.0	3.1	193
SMBJ130	144	176	1.0	130	5.0	2.6	231
SMBJ130A	144	159	1.0	130	5.0	2.9	209
SMBJ150	167	204	1.0	150	5.0	2.2	268
SMBJ150A	167	185	1.0	150	5.0	2.5	243
SMBJ160	178	218	1.0	160	5.0	2.1	287
SMBJ160A	178	197	1.0	160	5.0	2.3	259
SMBJ170	189	231	1.0	170	5.0	2.0	304
SMBJ170A	189	209	1.0	170	5.0	2.2	275
SMBJ188	209	255	1.0	188	5.0	1.7	344
SMBJ188A	209	231	1.0	188	5.0	2.0	328

Notes:

- (1) Pulse test : $t_p \leq 50ms$
- (2) For bidirectional use suffix "C" or "CA"
- (3) For bidirectional types with V_{WM} of 10 Volts and less, the I_R limit is doubled
- (4) For the bidirectional SMBJ5.0CA, the maximum V_{BR} is 7.25V
- (5) "SMBJ" will be omitted on marking of the diode



Transient Voltage Suppressor Diodes

The plastic material carries U/L recognition 94V-O.

Type No.		Breakdown Voltage @ It (Note 1)		Working Peak Reverse Voltage	Maximum Reverse Leakage @ VRWM	Maximum Reverse Current	Maximum Clamping Voltage @ IRSM	Maximum Temperature Coefficient of VBR	
Unidirectional Axial Lead	SMD	VBR (V) Min.	Max.	It (mA)	VRWM (V)	IR (μA)	IRSM (A)	VRSM (V)	(% / °C)

1N6267/STUN Series, 1,500 W, Case Type: DO-201/SMC



1N6267	STUN06I	6.12	7.48	10	5.50	1000	139	10.8	0.057
1N6267A	STUN56I	6.45	7.14	10	5.80	1000	143	10.5	0.057
1N6268	STUN07F	6.75	8.25	10	6.05	500	128	11.7	0.061
1N6268A	STUN57F	7.13	7.88	10	6.40	500	132	11.3	0.061
1N6269	STUN08C	7.38	9.02	10	6.63	200	120	12.5	0.065
1N6269A	STUN58C	7.79	8.61	10	7.02	200	124	12.1	0.065
1N6270	STUN09B	8.19	10.0	1.0	7.37	50	109	13.8	0.068
1N6270A	STUN59B	8.65	9.55	1.0	7.78	50	112	13.4	0.068
1N6271	STUN010	9.00	11.0	1.0	8.10	10	100	15.0	0.073
1N6271A	STUN510	9.50	10.5	1.0	8.55	10	103	14.5	0.073
1N6272	STUN011	9.90	12.1	1.0	8.92	5.0	93.0	16.2	0.075
1N6272A	STUN511	10.5	11.6	1.0	9.40	5.0	96.0	15.6	0.075
1N6273	STUN012	10.8	13.2	1.0	9.72	5.0	87.0	17.3	0.078
1N6273A	STUN512	11.4	12.6	1.0	10.2	5.0	90.0	16.7	0.078
1N6274	STUN013	11.7	14.3	1.0	10.5	5.0	79.0	19.0	0.081
1N6274A	STUN513	12.4	13.7	1.0	11.1	5.0	82.0	18.2	0.081
1N6275	STUN015	13.5	16.3	1.0	12.1	5.0	68.0	22.0	0.084
1N6275A	STUN515	14.3	15.8	1.0	12.8	5.0	71.0	21.2	0.084
1N6276	STUN016	14.4	17.6	1.0	12.9	5.0	64.0	23.5	0.086
1N6276A	STUN516	15.2	16.8	1.0	13.6	5.0	67.0	22.5	0.086
1N6277	STUN018	16.2	19.8	1.0	14.5	5.0	56.5	26.5	0.088
1N6277A	STUN518	17.1	18.9	1.0	15.3	5.0	59.5	25.2	0.088
1N6278	STUN020	18.0	22.0	1.0	16.2	5.0	51.5	29.1	0.090
1N6278A	STUN520	19.0	21.0	1.0	17.1	5.0	54.0	27.7	0.090
1N6279	STUN022	19.8	24.2	1.0	17.8	5.0	47.0	31.9	0.092
1N6279A	STUN522	20.9	23.1	1.0	18.8	5.0	49.0	30.6	0.092
1N6280	STUN024	21.6	26.4	1.0	19.4	5.0	43.0	34.7	0.094
1N6280A	STUN524	22.8	25.2	1.0	20.5	5.0	45.0	33.2	0.094
1N6281	STUN027	24.3	29.7	1.0	21.8	5.0	38.5	39.1	0.096
1N6281A	STUN527	25.7	28.4	1.0	23.1	5.0	40.0	37.5	0.096
1N6282	STUN030	27.0	33.0	1.0	24.3	5.0	34.5	43.5	0.097
1N6282A	STUN530	28.5	31.5	1.0	25.6	5.0	36.0	41.4	0.097
1N6283	STUN033	29.7	36.3	1.0	26.8	5.0	31.5	47.7	0.098
1N6283A	STUN533	31.4	34.7	1.0	28.2	5.0	33.0	45.7	0.098
1N6284	STUN036	32.4	39.6	1.0	29.1	5.0	29.0	52.0	0.099
1N6284A	STUN536	34.2	37.8	1.0	30.8	5.0	30.0	49.9	0.099
1N6285	STUN039	35.1	42.9	1.0	31.6	5.0	26.5	56.4	0.100
1N6285A	STUN539	37.1	41.0	1.0	33.3	5.0	28.0	53.9	0.100
1N6286	STUN043	38.7	47.3	1.0	34.8	5.0	24.0	61.9	0.101
1N6286A	STUN543	40.9	45.2	1.0	36.8	5.0	25.3	59.3	0.101
1N6287	STUN047	42.3	51.7	1.0	38.1	5.0	22.2	67.8	0.101
1N6287A	STUN547	44.7	49.4	1.0	40.2	5.0	23.2	64.8	0.101



Transient Voltage Suppressor Diodes

The plastic material carries U/L recognition 94V-O.

Type No.		Breakdown Voltage @ It (Note 1)			Working Peak Reverse Voltage	Maximum Reverse Leakage @ VRWM	Maximum Reverse Current	Maximum Clamping Voltage @ IRSM	Maximum Temperature Coefficient of VBR
		VBR (V)		It					
Axial Lead	SMD	Min.	Max.	(mA)	(V)	(μ A)	(A)	(V)	(% / °C)

1N6267/STUN Series, 1,500 W, Case Type: DO-201/SMC



1N6288	STUN051	45.9	56.1	1.0	41.3	5.0	20.4	73.5	0.102
1N6288A	STUN551	48.5	53.6	1.0	43.6	5.0	21.4	70.1	0.102
1N6289	STUN056	50.4	61.6	1.0	45.4	5.0	18.6	80.5	0.103
1N6289A	STUN556	53.2	58.8	1.0	47.8	5.0	19.5	77.0	0.103
1N6290	STUN062	55.8	68.2	1.0	50.2	5.0	16.9	89.0	0.104
1N6290A	STUN562	58.9	65.1	1.0	53.0	5.0	17.7	85.0	0.104
1N6291	STUN068	61.2	74.8	1.0	55.1	5.0	15.3	98.0	0.104
1N6291A	STUN568	64.6	71.4	1.0	58.1	5.0	16.3	92.0	0.104
1N6292	STUN075	67.5	82.5	1.0	60.7	5.0	13.9	108	0.105
1N6292A	STUN575	71.3	78.8	1.0	64.1	5.0	14.6	103	0.105
1N6293	STUN082	73.8	90.2	1.0	66.4	5.0	12.7	118	0.105
1N6293A	STUN582	77.9	86.1	1.0	70.1	5.0	13.3	113	0.105
1N6294	STUN091	81.9	100	1.0	73.7	5.0	11.4	131	0.106
1N6294A	STUN591	86.5	95.5	1.0	77.8	5.0	12.0	125	0.106
1N6295	STUN0B0	90.0	110	1.0	81.0	5.0	10.4	144	0.106
1N6295A	STUN5B0	95.0	105	1.0	85.5	5.0	11.0	137	0.106
1N6296	STUN0B1	99.0	121	1.0	89.2	5.0	9.5	158	0.107
1N6296A	STUN5B1	105	116	1.0	94.0	5.0	9.9	152	0.107
1N6297	STUN0B2	108	132	1.0	97.2	5.0	8.7	173	0.107
1N6297A	STUN5B2	114	126	1.0	102	5.0	9.1	165	0.107
1N6298	STUN0B3	117	143	1.0	105	5.0	8.0	187	0.107
1N6298A	STUN5B3	124	137	1.0	111	5.0	8.4	179	0.107
1N6299	STUN0B5	135	165	1.0	121	5.0	7.0	215	0.108
1N6299A	STUN5B5	143	158	1.0	128	5.0	7.2	207	0.108
1N6300	STUN0B6	144	176	1.0	130	5.0	6.5	230	0.108
1N6300A	STUN5B6	152	168	1.0	136	5.0	6.8	219	0.108
1N6301	STUN0B7	153	187	1.0	138	5.0	6.2	244	0.108
1N6301A	STUN5B7	162	179	1.0	145	5.0	6.4	234	0.108
1N6302	STUN0B8	162	198	1.0	146	5.0	5.8	258	0.108
1N6302A	STUN5B8	171	189	1.0	154	5.0	6.1	246	0.108
1N6303	STUN0D0	180	220	1.0	162	5.0	5.2	287	0.108
1N6303A	STUN5D0	190	210	1.0	171	5.0	5.5	274	0.108

Notes:

- (1) VBR measured after It applied for 300 μ s., It = square wave pulse or equivalent
- (2) VF = 3.5 Vmax., IF = 100 A (6.8 V to 91 V)
VF = 5.0 Vmax., IF = 100 A (100 V to 200 V) per 1/2 square or equivalent sine wave
PW = 8.3 ms, duty cycle = 4 pulses per minute maximum
- (3) For bidirectional use suffix "C" or "CA" (Axial Lead) / replace the third letter of type from "U" to "B" (SMD)
- (4) "STU" or "STB" will be omitted on marking of the diode.
- (5) Add suffix "L" (Axial Lead) for case type DO-201AD
- (6) For bidirectional types have VR of 10 V and under, the IR limit is doubled.



Transient Voltage Suppressor Diodes

The plastic material carries U/L recognition 94V-O.

Type No.		Breakdown Voltage @ It (Note 1)		Working Peak Reverse Voltage	Maximum Reverse Leakage @ VRWM	Maximum Reverse Current	Maximum Clamping Voltage @ IRSM	Maximum Temperature Coefficient of VBR
		VBR (V)	It (mA)					
Unidirectional		Min.	Max.					
Axial Lead	SMD							(% / °C)

1.5KE/STUK Series, 1,500 W, Case Type: DO-201/SMC



1.5KE6.8	STUK06I	6.12	7.48	10	5.50	1000	139	10.8	0.057
1.5KE6.8A	STUK56I	6.45	7.14	10	5.80	1000	143	10.5	0.057
1.5KE7.5	STUK07F	6.75	8.25	10	6.05	500	128	11.7	0.061
1.5KE7.5A	STUK57F	7.13	7.88	10	6.40	500	132	11.3	0.061
1.5KE8.2	STUK08C	7.38	9.02	10	6.63	200	120	12.5	0.065
1.5KE8.2A	STUK58C	7.79	8.61	10	7.02	200	124	12.1	0.065
1.5KE9.1	STUK09B	8.19	10.0	1.0	7.37	50	109	13.8	0.068
1.5KE9.1A	STUK59B	8.65	9.55	1.0	7.78	50	112	13.4	0.068
1.5KE10	STUK010	9.00	11.0	1.0	8.10	10	100	15.0	0.073
1.5KE10A	STUK510	9.50	10.5	1.0	8.55	10	103	14.5	0.073
1.5KE11	STUK011	9.90	12.1	1.0	8.92	5.0	93.0	16.2	0.075
1.5KE11A	STUK511	10.5	11.6	1.0	9.40	5.0	96.0	15.6	0.075
1.5KE12	STUK012	10.8	13.2	1.0	9.72	5.0	87.0	17.3	0.078
1.5KE12A	STUK512	11.4	12.6	1.0	10.2	5.0	90.0	16.7	0.078
1.5KE13	STUK013	11.7	14.3	1.0	10.5	5.0	79.0	19.0	0.081
1.5KE13A	STUK513	12.4	13.7	1.0	11.1	5.0	82.0	18.2	0.081
1.5KE15	STUK015	13.5	16.5	1.0	12.1	5.0	68.0	22.0	0.084
1.5KE15A	STUK515	14.3	15.8	1.0	12.8	5.0	71.0	21.2	0.084
1.5KE16	STUK016	14.4	17.6	1.0	12.9	5.0	64.0	23.5	0.086
1.5KE16A	STUK516	15.2	16.8	1.0	13.6	5.0	67.0	22.5	0.086
1.5KE18	STUK018	16.2	19.8	1.0	14.5	5.0	56.5	26.5	0.088
1.5KE18A	STUK518	17.1	18.9	1.0	15.3	5.0	59.5	25.2	0.088
1.5KE20	STUK020	18.0	22.0	1.0	16.2	5.0	51.5	29.1	0.090
1.5KE20A	STUK520	19.0	21.0	1.0	17.1	5.0	54.0	27.7	0.090
1.5KE22	STUK022	19.8	24.2	1.0	17.8	5.0	47.0	31.9	0.092
1.5KE22A	STUK522	20.9	23.1	1.0	18.8	5.0	49.0	30.6	0.092
1.5KE24	STUK024	21.6	26.4	1.0	19.4	5.0	43.0	34.7	0.094
1.5KE24A	STUK524	22.8	25.2	1.0	20.5	5.0	45.0	33.2	0.094
1.5KE27	STUK027	24.3	29.7	1.0	21.8	5.0	38.5	39.1	0.096
1.5KE27A	STUK527	25.7	28.4	1.0	23.1	5.0	40.0	37.5	0.096
1.5KE30	STUK030	27.0	33.0	1.0	24.3	5.0	34.5	43.5	0.097
1.5KE30A	STUK530	28.5	31.5	1.0	25.6	5.0	36.0	41.4	0.097
1.5KE33	STUK033	29.7	36.3	1.0	26.8	5.0	31.5	47.7	0.098
1.5KE33A	STUK533	31.4	34.7	1.0	28.2	5.0	33.0	45.7	0.098
1.5KE36	STUK036	32.4	39.6	1.0	29.1	5.0	29.0	52.0	0.099
1.5KE36A	STUK536	34.2	37.8	1.0	30.8	5.0	30.0	49.9	0.099
1.5KE39	STUK039	35.1	42.9	1.0	31.6	5.0	26.5	56.4	0.100
1.5KE39A	STUK539	37.1	41.0	1.0	33.3	5.0	28.0	53.9	0.100
1.5KE43	STUK043	38.7	47.3	1.0	34.8	5.0	24.0	61.9	0.101
1.5KE43A	STUK543	40.9	45.2	1.0	36.8	5.0	25.3	59.3	0.101
1.5KE47	STUK047	42.3	51.7	1.0	38.1	5.0	22.2	67.8	0.101
1.5KE47A	STUK547	44.7	49.4	1.0	40.2	5.0	23.2	64.8	0.101
1.5KE51	STUK051	45.9	56.1	1.0	41.3	5.0	20.4	73.5	0.102
1.5KE51A	STUK551	48.5	53.6	1.0	43.6	5.0	21.4	70.1	0.102
1.5KE56	STUK056	50.4	61.6	1.0	45.4	5.0	18.6	80.5	0.103
1.5KE56A	STUK556	53.2	58.8	1.0	47.8	5.0	19.5	77.0	0.103
1.5KE62	STUK062	55.8	68.2	1.0	50.2	5.0	16.9	89.0	0.104
1.5KE62A	STUK562	58.9	65.1	1.0	53.0	5.0	17.7	85.0	0.104



Transient Voltage Suppressor Diodes

The plastic material carries U/L recognition 94V-O.

Type No.	Breakdown Voltage @ I_t (Note 1)		Working Peak Reverse Voltage	Maximum Reverse Leakage @ V_{RWM}	Maximum Reverse Current	Maximum Clamping Voltage @ I_{RSM}	Maximum Temperature Coefficient of V_{BR}
	V_{BR} (V)	I_t (mA)					
Unidirectional	Min.	Max.	(V)	(μ A)	(A)	(V)	(% / °C)
Axial Lead	SMD						

1.5KE/STUK Series, 1,500 W, Case Type: DO-201/SMC



1.5KE68	STUK068	61.2	74.8	1.0	55.1	5.0	15.3	98.0	0.104
1.5KE68A	STUK568	64.6	71.4	1.0	58.1	5.0	16.3	92.0	0.104
1.5KE75	STUK075	67.5	82.5	1.0	60.7	5.0	13.9	108	0.105
1.5KE75A	STUK575	71.3	78.8	1.0	64.1	5.0	14.6	103	0.105
1.5KE82	STUK082	73.8	90.2	1.0	66.4	5.0	12.7	118	0.105
1.5KE82A	STUK582	77.9	86.1	1.0	70.1	5.0	13.3	113	0.105
1.5KE91	STUK091	81.9	100	1.0	73.7	5.0	11.4	131	0.106
1.5KE91A	STUK591	86.5	95.5	1.0	77.8	5.0	12.0	125	0.106
1.5KE100	STUK0B0	90.0	110	1.0	81.0	5.0	10.4	144	0.106
1.5KE100A	STUK5B0	95.0	105	1.0	85.5	5.0	11.0	137	0.106
1.5KE110	STUK0B1	99.0	121	1.0	89.2	5.0	9.5	158	0.107
1.5KE110A	STUK5B1	105	116	1.0	94.0	5.0	9.9	152	0.107
1.5KE120	STUK0B2	108	132	1.0	97.2	5.0	8.7	173	0.107
1.5KE120A	STUK5B2	114	126	1.0	102	5.0	9.1	165	0.107
1.5KE130	STUK0B3	117	143	1.0	105	5.0	8.0	187	0.107
1.5KE130A	STUK5B3	124	137	1.0	111	5.0	8.4	179	0.107
1.5KE150	STUK0B5	135	165	1.0	121	5.0	7.0	215	0.108
1.5KE150A	STUK5B5	143	158	1.0	128	5.0	7.2	207	0.108
1.5KE160	STUK0B6	144	176	1.0	130	5.0	6.5	230	0.108
1.5KE160A	STUK5B6	152	168	1.0	136	5.0	6.8	219	0.108
1.5KE170	STUK0B7	153	187	1.0	138	5.0	6.2	244	0.108
1.5KE170A	STUK5B7	162	179	1.0	145	5.0	6.4	234	0.108
1.5KE180	STUK0B8	162	198	1.0	146	5.0	5.8	258	0.108
1.5KE180A	STUK5B8	171	189	1.0	154	5.0	6.1	246	0.108
1.5KE200	STUK0D0	180	220	1.0	162	5.0	5.2	287	0.108
1.5KE200A	STUK5D0	190	210	1.0	171	5.0	5.5	274	0.108
1.5KE220	STUK0D2	198	242	1.0	175	5.0	4.3	344	0.108
1.5KE220A	STUK5D2	209	231	1.0	185	5.0	4.6	328	0.108
1.5KE250	STUK0D5	225	275	1.0	202	5.0	4.2	360	0.110
1.5KE250A	STUK5D5	237	263	1.0	214	5.0	4.4	344	0.110
1.5KE300	STUK0E0	270	330	1.0	243	5.0	3.5	430	0.110
1.5KE300A	STUK5E0	285	315	1.0	256	5.0	3.6	414	0.110
1.5KE350	STUK0E5	315	385	1.0	284	5.0	3.0	504	0.110
1.5KE350A	STUK5E5	332	368	1.0	300	5.0	3.1	482	0.110
1.5KE400	STUK0G0	360	440	1.0	324	5.0	2.6	574	0.110
1.5KE400A	STUK5G0	380	420	1.0	342	5.0	2.7	548	0.110
1.5KE440	STUK0G4	396	484	1.0	356	5.0	2.4	631	0.110
1.5KE440A	STUK5G4	418	462	1.0	376	5.0	2.5	602	0.110

Notes:

- (1) V_{BR} measured after I_t applied for 300 μ s., I_t = square wave pulse or equivalent
- (2) $V_F = 3.5 V_{max.}$, $I_F = 100$ A (6.8 V to 91 V)
 $V_F = 5.0 V_{max.}$, $I_F = 100$ A (100 V to 440 V) per 1/2 square or equivalent sine wave
 $PW = 8.3$ ms, duty cycle = 4 pulses per minute maximum
- (3) For bidirectional use suffix "C" or "CA" (Axial Lead) / replace the third letter of type from "U" to "B" (SMD)
- (4) "1.5" for axial lead / "STU" or "STB" for SMD will be omitted on marking of the diode.
- (5) Use suffix "L" (Axial Lead) for case type DO-201AD
- (6) For bidirectional types have V_R of 10 V and under, the I_R limit is doubled



Transient Voltage Suppressor Diodes

The plastic material carries U/L recognition 94V-O.

Type No.	Breakdown Voltage @ $I_T^{(1)}$		Working Peak Reverse Voltage	Maximum Reverse Leakage @ V_{WM}	Maximum Peak Pulse Surge Current	Maximum Clamping Voltage @ I_{PPM}	
	V_{BR} (V)						I_T
Unidirectional	Min.	Max.	(mA)	(V)	(μ A)	(A)	(V)

SMCJ Series, 1,500W, Case Type: SMC



SMCJ5.0	6.40	7.82	10	5.0	1000	156.3	9.6
SMCJ5.0A	6.40	7.07	10	5.0	1000	163.0	9.2
SMCJ6.0	6.67	8.15	10	6.0	1000	131.6	11.4
SMCJ6.0A	6.67	7.37	10	6.0	1000	145.6	10.3
SMCJ6.5	7.22	8.82	10	6.5	500	122.0	12.3
SMCJ6.5A	7.22	7.98	10	6.5	500	133.9	11.2
SMCJ7.0	7.78	9.51	10	7.0	200	112.8	13.3
SMCJ7.0A	7.78	8.6	10	7.0	200	125.0	12.0
SMCJ7.5	8.33	10.2	1.0	7.5	100	104.9	14.3
SMCJ7.5A	8.33	9.21	1.0	7.5	100	116.3	12.9
SMCJ8.0	8.89	10.9	1.0	8.0	50	100.0	15.0
SMCJ8.0A	8.89	9.83	1.0	8.0	50	110.3	13.6
SMCJ8.5	9.44	11.5	1.0	8.5	20	94.3	15.9
SMCJ8.5A	9.44	10.4	1.0	8.5	20	104.2	14.4
SMCJ9.0	10.0	12.2	1.0	9.0	10	88.8	16.9
SMCJ9.0A	10.0	11.1	1.0	9.0	10	97.4	15.4
SMCJ10	11.1	13.6	1.0	10	5.0	79.8	18.8
SMCJ10A	11.1	12.3	1.0	10	5.0	88.2	17.0
SMCJ11	12.2	14.9	1.0	11	5.0	74.6	20.1
SMCJ11A	12.2	13.5	1.0	11	5.0	82.4	18.2
SMCJ12	13.3	16.3	1.0	12	5.0	68.2	22.0
SMCJ12A	13.3	14.7	1.0	12	5.0	75.4	19.9
SMCJ13	14.4	17.6	1.0	13	1.0	63.0	23.8
SMCJ13A	14.4	15.9	1.0	13	1.0	69.8	21.5
SMCJ14	15.6	19.1	1.0	14	1.0	58.1	25.8
SMCJ14A	15.6	17.2	1.0	14	1.0	64.7	23.2
SMCJ15	16.7	20.4	1.0	15	1.0	55.8	26.9
SMCJ15A	16.7	18.5	1.0	15	1.0	61.5	24.4
SMCJ16	17.8	21.8	1.0	16	1.0	52.1	28.8
SMCJ16A	17.8	19.7	1.0	16	1.0	57.7	26.0
SMCJ17	18.9	23.1	1.0	17	1.0	49.2	30.5
SMCJ17A	18.9	20.9	1.0	17	1.0	54.3	27.6
SMCJ18	20.0	24.4	1.0	18	1.0	46.6	32.2
SMCJ18A	20.0	22.1	1.0	18	1.0	51.4	29.2
SMCJ20	22.2	27.1	1.0	20	1.0	41.9	35.8
SMCJ20A	22.2	24.5	1.0	20	1.0	46.3	32.4
SMCJ22	24.4	29.8	1.0	22	1.0	38.1	39.4
SMCJ22A	24.4	26.9	1.0	22	1.0	42.3	35.5
SMCJ24	26.7	32.6	1.0	24	1.0	34.9	43.0
SMCJ24A	26.7	29.5	1.0	24	1.0	38.6	38.9
SMCJ26	28.9	35.3	1.0	26	1.0	32.2	46.6
SMCJ26A	28.9	31.9	1.0	26	1.0	35.6	42.1
SMCJ28	31.1	38.0	1.0	28	1.0	30.0	50.0
SMCJ28A	31.1	34.4	1.0	28	1.0	33.0	45.4
SMCJ30	33.3	40.7	1.0	30	1.0	28.0	53.5
SMCJ30A	33.3	36.8	1.0	30	1.0	31.0	48.4
SMCJ33	36.7	44.9	1.0	33	1.0	25.4	59.0
SMCJ33A	36.7	40.6	1.0	33	1.0	28.1	53.3
SMCJ36	40.0	48.9	1.0	36	1.0	23.3	64.3
SMCJ36A	40.0	44.2	1.0	36	1.0	25.8	58.1
SMCJ40	44.4	54.3	1.0	40	1.0	21.0	71.4
SMCJ40A	44.4	49.1	1.0	40	1.0	23.3	64.5



Transient Voltage Suppressor Diodes

The plastic material carries U/L recognition 94V-O.

Type No.	Breakdown Voltage @ $I_T^{(1)}$		I_T	Working Peak Reverse Voltage	Maximum Reverse Leakage @ V_{WM}	Maximum Peak Pulse Surge Current	Maximum Clamping Voltage @ I_{PPM}
	V_{BR} (V)						
Unidirectional	Min.	Max.	(mA)	(V)	(μ A)	(A)	(V)

SMCJ Series, 1,500W, Case Type: SMC



SMCJ43	47.8	58.4	1.0	43	1.0	19.6	76.7
SMCJ43A	47.8	52.8	1.0	43	1.0	21.6	69.4
SMCJ45	50.0	61.1	1.0	45	1.0	18.7	80.3
SMCJ45A	50.0	55.3	1.0	45	1.0	20.6	72.7
SMCJ48	53.3	65.1	1.0	48	1.0	17.5	85.5
SMCJ48A	53.3	58.9	1.0	48	1.0	19.4	77.4
SMCJ51	56.7	69.3	1.0	51	1.0	16.5	91.1
SMCJ51A	56.7	62.7	1.0	51	1.0	18.2	82.4
SMCJ54	60.0	73.3	1.0	54	1.0	15.6	96.3
SMCJ54A	60.0	66.3	1.0	54	1.0	17.2	87.1
SMCJ58	64.4	78.7	1.0	58	1.0	14.6	103
SMCJ58A	64.4	71.2	1.0	58	1.0	16.0	93.6
SMCJ60	66.7	81.5	1.0	60	1.0	14.0	107
SMCJ60A	66.7	73.7	1.0	60	1.0	15.5	96
SMCJ64	71.1	86.4	1.0	64	1.0	13.2	114
SMCJ64A	71.1	78.6	1.0	64	1.0	14.6	103
SMCJ70	77.8	95.1	1.0	70	1.0	12.0	125
SMCJ70A	77.8	86	1.0	70	1.0	13.3	113
SMCJ75	83.3	102	1.0	75	1.0	11.2	134
SMCJ75A	83.3	92.1	1.0	75	1.0	12.4	121
SMCJ78	86.7	106	1.0	78	1.0	10.8	139
SMCJ78A	86.7	95.8	1.0	78	1.0	11.9	126
SMCJ85	94.4	115	1.0	85	1.0	9.9	151
SMCJ85A	94.4	104	1.0	85	1.0	10.9	137
SMCJ90	100	122	1.0	90	1.0	9.4	160
SMCJ90A	100	111	1.0	90	1.0	10.3	146
SMCJ100	111	136	1.0	100	1.0	8.4	179
SMCJ100A	111	123	1.0	100	1.0	9.3	162
SMCJ110	122	149	1.0	110	1.0	7.7	196
SMCJ110A	122	135	1.0	110	1.0	8.5	177
SMCJ120	133	163	1.0	120	1.0	7.0	214
SMCJ120A	133	147	1.0	120	1.0	7.8	193
SMCJ130	144	176	1.0	130	1.0	6.5	231
SMCJ130A	144	159	1.0	130	1.0	7.2	209
SMCJ150	167	204	1.0	150	1.0	5.6	268
SMCJ150A	167	185	1.0	150	1.0	6.2	243
SMCJ160	178	218	1.0	160	1.0	5.2	287
SMCJ160A	178	197	1.0	160	1.0	5.8	259
SMCJ170	189	231	1.0	170	1.0	4.90	304
SMCJ170A	189	209	1.0	170	1.0	5.50	275
SMCJ188	209	255	1.0	188	1.0	4.40	344
SMCJ188A	209	231	1.0	188	1.0	4.60	328

Notes :

- (1) Pulse test : $t_p \leq 50\text{ms}$
- (2) For bidirectional use suffix "C" or "CA"
- (3) For bidirectional types have V_{WM} of 10 V and less , the I_R limit is doubled
- (4) For the bidirectional SMCJ5.0CA, the maximum V_{BR} is 7.25V
- (5) "SMCJ" will be omitted on marking of the diode



Transient Voltage Suppressor Diodes

The plastic material carries U/L recognition 94V-O.

Type No.	Breakdown Voltage @ I_T		I_T (mA)	Working Peak Reverse Voltage V_{WM} (V)	Maximum Reverse Leakage @ V_{WM} I_R (μ A)	Maximum Peak Pulse Surge Current I_{PPM} (A)	Maximum Clamping Voltage @ I_{PPM} V_C (V)
	Min.	Max.					

3.0SMCJ Series, 3,000W, Case Type: SMC



3.0SMCJ11	12.2	15.4	1.0	11	1000	149.2	20.1
3.0SMCJ11A	12.2	14.0	1.0	11	1000	184.8	18.2
3.0SMCJ12	13.3	16.9	1.0	12	1000	136.4	22.0
3.0SMCJ12A	13.3	15.3	1.0	12	1000	150.6	19.9
3.0SMCJ13	14.4	18.2	1.0	13	500	126.0	23.8
3.0SMCJ13A	14.4	16.5	1.0	13	500	139.4	21.5
3.0SMCJ14	15.6	19.8	1.0	14	200	116.2	25.8
3.0SMCJ14A	15.6	17.9	1.0	14	200	129.4	23.2
3.0SMCJ15	16.7	21.1	1.0	15	100	111.6	26.9
3.0SMCJ15A	16.7	19.2	1.0	15	100	123.0	24.4
3.0SMCJ16	17.8	22.6	1.0	16	50	104.2	28.8
3.0SMCJ16A	17.8	20.5	1.0	16	50	115.4	26.0
3.0SMCJ17	18.9	23.9	1.0	17	20	98.4	30.5
3.0SMCJ17A	18.9	21.7	1.0	17	20	106.6	27.6
3.0SMCJ18	20.0	25.3	1.0	18	10	93.2	32.2
3.0SMCJ18A	20.0	23.3	1.0	18	10	102.8	29.2
3.0SMCJ20	22.2	28.1	1.0	20	10	83.8	35.8
3.0SMCJ20A	22.2	25.5	1.0	20	10	92.6	32.4
3.0SMCJ22	24.4	30.9	1.0	22	5	76.2	39.4
3.0SMCJ22A	24.4	28.0	1.0	22	5	84.4	35.5
3.0SMCJ24	26.7	33.8	1.0	24	5	69.8	43.0
3.0SMCJ24A	26.7	30.7	1.0	24	5	77.2	38.9
3.0SMCJ26	28.9	36.6	1.0	26	5	64.4	46.6
3.0SMCJ26A	28.9	33.2	1.0	26	5	71.2	42.1
3.0SMCJ28	31.1	39.4	1.0	28	5	60.0	50.0
3.0SMCJ28A	31.1	35.8	1.0	28	5	66.0	45.4
3.0SMCJ30	33.3	42.2	1.0	30	5	56.0	53.5
3.0SMCJ30A	33.3	38.3	1.0	30	5	62.0	48.4
3.0SMCJ33	36.7	46.5	1.0	33	5	50.4	59.0
3.0SMCJ33A	36.7	42.2	1.0	33	5	56.2	53.3
3.0SMCJ36	40.0	50.7	1.0	36	5	46.6	64.3
3.0SMCJ36A	40.0	46.0	1.0	36	5	51.6	58.1
3.0SMCJ40	44.4	56.3	1.0	40	5	42.0	71.4
3.0SMCJ40A	44.4	51.1	1.0	40	5	46.4	64.5
3.0SMCJ43	47.8	60.5	1.0	43	5	39.2	76.7
3.0SMCJ43A	47.8	54.9	1.0	43	5	43.2	69.4
3.0SMCJ45	50.0	63.3	1.0	45	5	37.4	80.3
3.0SMCJ45A	50.0	57.5	1.0	45	5	41.2	72.7
3.0SMCJ48	53.3	67.5	1.0	48	5	35.0	85.5
3.0SMCJ48A	53.3	61.3	1.0	48	5	38.8	77.4
3.0SMCJ51	56.7	71.8	1.0	51	5	37.0	91.1
3.0SMCJ51A	56.7	65.2	1.0	51	5	36.4	82.4
3.0SMCJ54	60.0	76.0	1.0	54	5	31.2	96.3
3.0SMCJ54A	60.0	69.0	1.0	54	5	34.4	87.1
3.0SMCJ58	64.4	81.6	1.0	58	5	39.2	103
3.0SMCJ58A	64.4	74.1	1.0	58	5	32.0	93.6



Transient Voltage Suppressor Diodes

The plastic material carries U/L recognition 94V-O.

Type No.	Breakdown Voltage @ I_T		I_T (mA)	Working Peak Reverse Voltage V_{WM} (V)	Maximum Reverse Leakage @ V_{WM} I_R (μ A)	Maximum Peak Pulse Surge Current I_{PPM} (A)	Maximum Clamping Voltage @ I_{PPM} V_C (V)
	Min.	Max.					

3.0SMCJ Series, 3,000W, Case Type: SMC



3.0SMCJ60	66.7	84.5	1.0	60	5	28.0	107
3.0SMCJ60A	66.7	76.7	1.0	60	5	31.0	96
3.0SMCJ64	71.1	90.1	1.0	64	5	26.4	114
3.0SMCJ64A	71.1	81.8	1.0	64	5	29.2	103
3.0SMCJ70	77.8	98.6	1.0	70	5	24.0	125
3.0SMCJ70A	77.8	89.5	1.0	70	5	26.6	113
3.0SMCJ75	83.3	105.7	1.0	75	5	22.4	134
3.0SMCJ75A	83.3	95.8	1.0	75	5	24.8	121
3.0SMCJ78	86.7	109.8	1.0	78	5	21.6	139
3.0SMCJ78A	86.7	99.7	1.0	78	5	22.8	126
3.0SMCJ85	94.4	119.2	1.0	85	5	19.8	151
3.0SMCJ85A	94.4	108.2	1.0	85	5	20.8	137
3.0SMCJ90	100	126.5	1.0	90	5	18.8	160
3.0SMCJ90A	100	115.5	1.0	90	5	20.6	146
3.0SMCJ100	111	141.0	1.0	100	5	16.6	179
3.0SMCJ100A	111	128.0	1.0	100	5	18.6	162
3.0SMCJ110	122	154.5	1.0	110	5	15.4	196
3.0SMCJ110A	122	140.5	1.0	110	5	16.8	177
3.0SMCJ120	133	169.0	1.0	120	5	14.0	214
3.0SMCJ120A	133	153.0	1.0	120	5	15.6	193
3.0SMCJ130	144	182.5	1.0	130	5	13.0	231
3.0SMCJ130A	144	165.5	1.0	130	5	14.4	209
3.0SMCJ150	167	211.5	1.0	150	5	11.2	268
3.0SMCJ150A	167	192.5	1.0	150	5	12.4	243
3.0SMCJ160	178	226.0	1.0	160	5	10.4	287
3.0SMCJ160A	178	205.0	1.0	160	5	11.6	259
3.0SMCJ170	189	239.5	1.0	170	5	9.8	304
3.0SMCJ170A	189	217.5	1.0	170	5	11.0	275
3.0SMCJ180	198	253.8	1.0	180	5	9.3	322
3.0SMCJ180A	198	230.4	1.0	180	5	10.3	292
3.0SMCJ190	209	267.9	1.0	190	5	8.8	340
3.0SMCJ190A	209	243.2	1.0	190	5	9.7	308
3.0SMCJ200	220	282.0	1.0	200	5	8.4	358
3.0SMCJ200A	220	256.0	1.0	200	5	9.3	324
3.0SMCJ210	231	296.1	1.0	210	5	7.8	376
3.0SMCJ210A	231	268.8	1.0	210	5	8.8	340
3.0SMCJ220	242	310.2	1.0	220	5	7.6	394
3.0SMCJ220A	242	281.6	1.0	220	5	8.4	356

Notes:

- (1) For bidirectional use suffix "C" or "CA"
- (2) "SMCJ" will be omitted on marking of the diode.



Transient Voltage Suppressor Diodes

The plastic material carries U/L recognition 94V-O.

Type No.	Breakdown Voltage @ I_t (Note 1)		Working Peak Reverse Voltage V_{RWM}	Maximum Reverse Leakage @ V_{RWM} I_R	Maximum Reverse Current I_{RSM}	Maximum Clamping Voltage @ I_{RSM} V_{RSM}	Maximum Temperature Coefficient of V_{BR} (% / °C)	
	V_{BR} (V)							
Unidirectional	Min.	Max.	(mA)	(V)	(μ A)	(A)	(V)	(% / °C)

3KE Series, 3,000 W, Case Type: DO-201



3KE13	11.7	14.3	10	10.5	1000	158	19.0	0.081
3KE13A	12.4	13.7	10	11.1	1000	164	18.2	0.081
3KE15	13.5	16.5	10	12.1	500	136	22.0	0.084
3KE15A	14.3	15.8	10	12.8	500	142	21.2	0.084
3KE16	14.4	17.6	10	12.9	200	128	23.5	0.086
3KE16A	15.2	16.8	10	13.6	200	134	22.5	0.086
3KE18	16.2	19.8	1.0	14.5	50	113	26.5	0.088
3KE18A	17.1	18.9	1.0	15.3	50	119	25.2	0.088
3KE20	18.0	22.0	1.0	16.2	10	103	29.1	0.090
3KE20A	19.0	21.0	1.0	17.1	10	108	27.7	0.090
3KE22	19.8	24.2	1.0	17.8	5.0	94	31.9	0.092
3KE22A	20.9	23.1	1.0	18.8	5.0	98	30.6	0.092
3KE24	21.6	26.4	1.0	19.4	5.0	86	34.7	0.094
3KE24A	22.8	25.2	1.0	20.5	5.0	90	33.2	0.094
3KE27	24.3	29.7	1.0	21.8	5.0	77	39.1	0.096
3KE27A	25.7	28.4	1.0	23.1	5.0	80	37.5	0.096
3KE30	27.0	33.0	1.0	24.3	5.0	69	43.5	0.097
3KE30A	28.5	31.5	1.0	25.6	5.0	72	41.4	0.097
3KE33	29.7	36.3	1.0	26.8	5.0	63	47.7	0.098
3KE33A	31.4	34.7	1.0	28.2	5.0	66	45.7	0.098
3KE36	32.4	39.6	1.0	29.1	5.0	58	52.0	0.099
3KE36A	34.2	37.8	1.0	30.8	5.0	60	49.9	0.099
3KE39	35.1	42.9	1.0	31.6	5.0	53	56.4	0.100
3KE39A	37.1	41.0	1.0	33.3	5.0	56	53.9	0.100
3KE43	38.7	47.3	1.0	34.8	5.0	48	61.9	0.101
3KE43A	40.9	45.2	1.0	36.8	5.0	51	59.3	0.101
3KE47	42.3	51.7	1.0	38.1	5.0	44	67.8	0.101
3KE47A	44.7	49.4	1.0	40.2	5.0	46	64.8	0.101
3KE51	45.9	56.1	1.0	41.3	5.0	41	73.5	0.102
3KE51A	48.5	53.6	1.0	43.6	5.0	43	70.1	0.102
3KE56	50.4	61.6	1.0	45.4	5.0	37	80.5	0.103
3KE56A	53.2	58.8	1.0	47.8	5.0	39	77.0	0.103
3KE62	55.8	68.2	1.0	50.2	5.0	34	89.0	0.104
3KE62A	58.9	65.1	1.0	53.0	5.0	35.4	85.0	0.104
3KE68	61.2	74.8	1.0	55.1	5.0	30.6	98.0	0.104
3KE68A	64.6	71.4	1.0	58.1	5.0	32.6	92.0	0.104
3KE75	67.5	82.5	1.0	60.7	5.0	27.8	108	0.105
3KE75A	71.3	78.8	1.0	64.1	5.0	29.2	103	0.105
3KE82	73.8	90.2	1.0	66.4	5.0	25.4	118	0.105
3KE82A	77.9	86.1	1.0	70.1	5.0	26.6	113	0.105
3KE91	81.9	100	1.0	73.7	5.0	22.8	131	0.106
3KE91A	86.5	95.5	1.0	77.8	5.0	24.0	125	0.106



Transient Voltage Suppressor Diodes

The plastic material carries U/L recognition 94V-0.

Type No.	Breakdown Voltage @ I_t (Note 1)		Working Peak Reverse Voltage	Maximum Reverse Leakage @ V_{RWM}	Maximum Reverse Current	Maximum Clamping Voltage @ I_{RSM}	Maximum Temperature Coefficient of V_{BR}	
	V_{BR} (V)							I_t
Unidirectional	Min.	Max.	(mA)	V_{RWM}	I_R	I_{RSM}	V_{RSM}	(% / °C)
					(V)	(μ A)	(A)	

3KE Series, 3,000 W, Case Type: DO-201



3KE100	90.0	110	1.0	81.0	5.0	20.8	144	0.106
3KE100A	95.0	105	1.0	85.5	5.0	22.0	137	0.106
3KE110	99.0	121	1.0	89.2	5.0	19.0	158	0.107
3KE110A	105	116	1.0	94.0	5.0	19.8	152	0.107
3KE120	108	132	1.0	97.2	5.0	17.4	173	0.107
3KE120A	114	126	1.0	102	5.0	18.2	165	0.107
3KE130	117	143	1.0	105	5.0	16.0	187	0.107
3KE130A	124	137	1.0	111	5.0	16.8	179	0.107
3KE150	135	165	1.0	121	5.0	14.0	215	0.108
3KE150A	143	158	1.0	128	5.0	14.4	207	0.108
3KE160	144	176	1.0	130	5.0	13.0	230	0.108
3KE160A	152	168	1.0	136	5.0	13.6	219	0.108
3KE170	153	187	1.0	138	5.0	12.4	244	0.108
3KE170A	162	179	1.0	145	5.0	12.8	234	0.108
3KE180	162	198	1.0	146	5.0	11.6	258	0.108
3KE180A	171	189	1.0	154	5.0	12.2	246	0.108
3KE200	180	220	1.0	162	5.0	10.4	287	0.108
3KE200A	190	210	1.0	171	5.0	11.0	274	0.108
3KE220	198	242	1.0	175	5.0	8.6	344	0.108
3KE220A	209	231	1.0	185	5.0	9.2	328	0.108
3KE250	225	275	1.0	202	5.0	10	360	0.110
3KE250A	237	263	1.0	214	5.0	10	344	0.110
3KE300	270	330	1.0	243	5.0	10	430	0.110
3KE300A	285	315	1.0	256	5.0	10	414	0.110
3KE350	315	385	1.0	284	5.0	8.0	504	0.110
3KE350A	332	368	1.0	300	5.0	8.0	482	0.110
3KE400	360	440	1.0	324	5.0	8.0	574	0.110
3KE400A	380	420	1.0	342	5.0	8.0	548	0.110
3KE440	396	484	1.0	356	5.0	4.8	631	0.110
3KE440A	418	462	1.0	376	5.0	5.0	602	0.110

Notes:

- (1) V_{BR} measured after I_t applied for 300 μ s., I_t = square wave pulse or equivalent
- (2) V_F = 5.0 Vmax., I_F = 100 A per 1/2 square or equivalent sine wave
PW = 8.3 ms, duty cycle = 4 pulses per minute maximum
- (3) For bidirectional use suffix "C" or "CA"
- (4) For bidirectional types having V_R of 20 V and under, the I_R limit is doubled



Transient Voltage Suppressor Diodes

The plastic material carries U/L recognition 94V-O.

Type No.	Breakdown Voltage @ I _T (Note 1)		Reverse Stand off Voltage V _{RM}	Maximum Reverse Leakage @ V _{RM} I _R	Maximum Peak Pulse Current (Note2) I _{PPM}	Maximum Clamping Voltage @ I _{PPM} V _C	Maximum Temperature Coefficient of V _{BR} (%/°C)
	V _{BR} (V)						
Unidirectional	Min.	Max.	(mA)	(V)	(A)	(V)	

5KP Series, 5,000W, Case Type: D6



5KP5.0	6.40	7.30	50	5.0	5000	520	9.60	0.057
5KP5.0A	6.40	7.00	50	5.0	5000	543	9.20	0.057
5KP6.0	6.67	8.15	50	6.0	5000	439	11.4	0.061
5KP6.0A	6.67	7.37	50	6.0	5000	485	10.3	0.061
5KP6.5	7.22	8.82	50	6.5	2000	407	12.3	0.065
5KP6.5A	7.22	7.98	50	6.5	2000	447	11.2	0.065
5KP7.0	7.78	9.51	5.0	7.0	1000	378	13.3	0.068
5KP7.0A	7.78	8.60	5.0	7.0	1000	417	12.0	0.068
5KP7.5	8.33	10.2	5.0	7.5	250	350	14.3	0.073
5KP7.5A	8.33	9.21	5.0	7.5	250	388	12.9	0.073
5KP8.0	8.89	10.9	5.0	8.0	150	333	15.0	0.075
5KP8.0A	8.89	9.83	5.0	8.0	150	367	13.6	0.075
5KP8.5	9.44	11.5	5.0	8.5	50	314	15.9	0.078
5KP8.5A	9.44	10.4	5.0	8.5	50	347	14.4	0.078
5KP9.0	10.0	12.2	5.0	9.0	20	295	16.9	0.081
5KP9.0A	10.0	11.1	5.0	9.0	20	325	15.4	0.081
5KP10	11.1	13.6	5.0	10	15	266	18.8	0.084
5KP10A	11.1	12.3	5.0	10	15	294	17.0	0.084
5KP11	12.2	14.9	5.0	11	10	249	20.1	0.086
5KP11A	12.2	13.5	5.0	11	10	274	18.2	0.086
5KP12	13.3	16.3	5.0	12	10	227	22.0	0.088
5KP12A	13.3	14.7	5.0	12	10	251	19.9	0.088
5KP13	14.4	17.6	5.0	13	10	210	23.8	0.090
5KP13A	14.4	15.9	5.0	13	10	232	21.5	0.090
5KP14	15.6	19.1	5.0	14	10	194	25.8	0.092
5KP14A	15.6	17.2	5.0	14	10	215	23.2	0.092
5KP15	16.7	20.4	5.0	15	10	188	26.9	0.094
5KP15A	16.7	18.5	5.0	15	10	206	24.4	0.094
5KP16	17.8	21.8	5.0	16	10	176	28.8	0.096
5KP16A	17.8	19.7	5.0	16	10	192	26.0	0.096
5KP17	18.9	23.1	5.0	17	10	164	30.5	0.097
5KP17A	18.9	20.9	5.0	17	10	181	27.6	0.097
5KP18	20.0	24.4	5.0	18	10	155	32.2	0.098
5KP18A	20.0	22.1	5.0	18	10	172	29.2	0.098
5KP20	22.2	27.1	5.0	20	10	139	35.8	0.099
5KP20A	22.2	24.5	5.0	20	10	154	32.4	0.099
5KP22	24.4	29.8	5.0	22	10	127	39.4	0.100
5KP22A	24.4	26.9	5.0	22	10	141	35.5	0.100
5KP24	26.7	32.6	5.0	24	10	116	43.0	0.101
5KP24A	26.7	29.5	5.0	24	10	128	38.9	0.101
5KP26	28.9	35.3	5.0	26	10	107	46.6	0.101
5KP26A	28.9	31.9	5.0	26	10	119	42.1	0.101
5KP28	31.1	38.0	5.0	28	10	99	50.1	0.102
5KP28A	31.1	34.4	5.0	28	10	110	45.4	0.102
5KP30	33.3	40.7	5.0	30	10	93	53.5	0.103
5KP30A	33.3	36.8	5.0	30	10	103	48.4	0.103
5KP33	36.7	44.9	5.0	33	10	85	59.0	0.104
5KP33A	36.7	40.6	5.0	33	10	94	53.3	0.104



Transient Voltage Suppressor Diodes

The plastic material carries U/L recognition 94V-O.

Type No.	Breakdown Voltage @ I_T (Note 1)		Reverse Stand off Voltage V_{RM} (V)	Maximum Reverse Leakage @ V_{RM} I_R (μ A)	Maximum Peak Pulse Current (Note2) I_{PPM} (A)	Maximum Clamping Voltage @ I_{PPM} V_C (V)	Maximum Temperature Coefficient of V_{BR} (%/°C)
	V_{BR} (V) Min.	I_T (mA) Max.					

5KP Series, 5,000W, Case Type: D6



5KP36	40.0	48.9	5.0	36	10	78	64.3	0.104
5KP36A	40.0	44.2	5.0	36	10	86	58.1	0.104
5KP40	44.4	54.3	5.0	40	10	70	71.4	0.105
5KP40A	44.4	49.1	5.0	40	10	78	64.5	0.105
5KP43	47.8	58.4	5.0	43	10	65	76.7	0.105
5KP43A	47.8	52.8	5.0	43	10	72	69.4	0.105
5KP45	50.0	61.1	5.0	45	10	62	80.3	0.106
5KP45A	50.0	55.3	5.0	45	10	69	72.7	0.106
5KP48	53.3	65.2	5.0	48	10	58	85.5	0.106
5KP48A	53.3	58.9	5.0	48	10	65	77.4	0.106
5KP51	56.7	69.3	5.0	51	10	55	91.1	0.107
5KP51A	56.7	62.7	5.0	51	10	61	82.4	0.107
5KP54	60.0	73.3	5.0	54	10	52	96.3	0.107
5KP54A	60.0	66.3	5.0	54	10	57	87.1	0.107
5KP56	62.2	76.1	5.0	56	10	50	100	0.107
5KP56A	62.2	68.8	5.0	56	10	55	91	0.107
5KP58	64.4	78.7	5.0	58	10	49	103	0.107
5KP58A	64.4	71.2	5.0	58	10	53	94	0.107
5KP60	66.7	81.5	5.0	60	10	47	107	0.108
5KP60A	66.7	73.7	5.0	60	10	52	97	0.108
5KP64	71.1	96.9	5.0	64	10	44	114	0.108
5KP64A	71.1	78.6	5.0	64	10	49	103	0.108
5KP70	77.6	95.1	5.0	70	10	40	125	0.108
5KP70A	77.6	86.0	5.0	70	10	44	113	0.108
5KP75	83.3	102	5.0	75	10	37	134	0.108
5KP75A	83.3	92.1	5.0	75	10	41	121	0.108
5KP78	86.7	106	5.0	78	10	36	139	0.108
5KP78A	86.7	95.8	5.0	78	10	40	126	0.108
5KP85	94.4	115	5.0	85	10	33	151	0.108
5KP85A	94.4	104	5.0	85	10	36	137	0.110
5KP90	100	122	5.0	90	10	31	160	0.110
5KP90A	100	111	5.0	90	10	34	146	0.110
5KP100	111	136	5.0	100	10	28	179	0.110
5KP100A	111	123	5.0	100	10	31	162	0.110
5KP110	122	149	5.0	110	10	26	196	0.112
5KP110A	122	135	5.0	110	10	28	177	0.112
5KP120	133	163	5.0	120	10	24	211	0.112
5KP120A	133	147	5.0	120	10	26	192	0.112
5KP150	167	204	5.0	150	10	19	263	0.112
5KP150A	167	184	5.0	150	10	21	238	0.112
5KP160	178	217	5.0	160	10	18	281	0.114
5KP160A	178	196	5.0	160	10	19	263	0.114
5KP180	200	244	5.0	180	10	16	316	0.114
5KP180A	200	221	5.0	180	10	17	290	0.114

Notes:

- (1) V_{BR} measured after I_T applied for 300 μ s., I_T = square wave pulse or equivalent
- (2) For bidirectional use suffix "C" or "CA"
- (3) V_F = 3.5 V max. for devices of V_R < 100 V, and V_F = 5 V max. for devices of V_R > 100 V
- (4) For bidirectional devices having V_R of 10 V and under, the I_R limit is doubled



Transient Voltage Suppressor Diodes

The plastic material carries U/L recognition 94V-O.

Type No.	Breakdown Voltage @ I_R (Note 1)		Stand - off Reverse Voltage V_{RM} (V)	Maximum Reverse Leakage @ V_{RM} I_R (μA)	Maximum Reverse Current I_{RSM} (A)	Maximum Clamping Voltage @ I_{RSM} V_{RSM} (V)	Maximum Temperature Coefficient αT (Note 2) ($10^{-4} / ^\circ C$)
	V_{BR} (V) Min.	I_R (mA) Max.					

BZW50 Series, 5,000W, Case Type: D6



BZW50-10	11.1	13.6	1.0	10	5.0	266	18.8	7.8
BZW50-12	13.3	16.3	1.0	12	5.0	227	22.0	8.4
BZW50-15	16.6	20.4	1.0	15	5.0	186	26.9	8.8
BZW50-18	20.0	24.4	1.0	18	5.0	155	32.2	9.2
BZW50-22	24.4	29.8	1.0	22	5.0	127	39.4	9.6
BZW50-27	30.0	36.6	1.0	27	5.0	103	48.3	9.8
BZW50-33	36.6	44.7	1.0	33	5.0	85	59.0	10
BZW50-39	43.3	53.0	1.0	39	5.0	72	69.4	10.1
BZW50-47	52.0	63.6	1.0	47	5.0	60.1	83.2	10.3
BZW50-56	62.2	76.0	1.0	56	5.0	50	99.6	10.4
BZW50-68	75.6	92.4	1.0	68	5.0	41	121	10.5
BZW50-82	91.0	111	1.0	82	5.0	34	145	10.6
BZW50-100	111	136	1.0	100	5.0	28	179	10.7
BZW50-120	133	163	1.0	120	5.0	23	215	10.8
BZW50-150	166	204	1.0	150	5.0	19	269	10.8
BZW50-180	200	244	1.0	180	5.0	16	322	10.8

Notes:

- (1) Pulse test : $t_p < 50$ ms
- (2) $\Delta V_{BR} = \alpha T * V_{BR}$ (25 $^\circ C$)
- (3) For bidirectional use suffix "B" (Axial Lead)



Transient Voltage Suppressor Diodes

The plastic material carries U/L recognition 94V-O.

Type No.	Breakdown Voltage @ I_T (Note 1)		Reverse Stand off Voltage	Maximum Reverse Leakage @ V_{RM}	Maximum Peak Pulse Current (Note2)	Maximum Clamping Voltage @ I_{PPM}	Maximum Temperature Coefficient of V_{BR} (%/°C)
	V_{BR} (V)	I_T					
Unidirectional	Min.	Max.	(mA)	V_{RM} (V)	I_R (μ A)	I_{PPM} (A)	V_C (V)

S5KP Series, 5,000W, Case Type: D²PAK



S5KP5.0	6.40	7.30	50	5.0	5000	520	9.60	0.057
S5KP5.0A	6.40	7.00	50	5.0	5000	543	9.20	0.057
S5KP6.0	6.67	8.15	50	6.0	5000	439	11.4	0.061
S5KP6.0A	6.67	7.37	50	6.0	5000	485	10.3	0.061
S5KP6.5	7.22	8.82	50	6.5	2000	407	12.3	0.065
S5KP6.5A	7.22	7.98	50	6.5	2000	447	11.2	0.065
S5KP7.0	7.78	9.51	5.0	7.0	1000	378	13.3	0.068
S5KP7.0A	7.78	8.60	5.0	7.0	1000	417	12.0	0.068
S5KP7.5	8.33	10.2	5.0	7.5	250	350	14.3	0.073
S5KP7.5A	8.33	9.21	5.0	7.5	250	388	12.9	0.073
S5KP8.0	8.89	10.9	5.0	8.0	150	333	15.0	0.075
S5KP8.0A	8.89	9.83	5.0	8.0	150	367	13.6	0.075
S5KP8.5	9.44	11.5	5.0	8.5	50	314	15.9	0.078
S5KP8.5A	9.44	10.4	5.0	8.5	50	347	14.4	0.078
S5KP9.0	10.0	12.2	5.0	9.0	20	295	16.9	0.081
S5KP9.0A	10.0	11.1	5.0	9.0	20	325	15.4	0.081
S5KP10	11.1	13.6	5.0	10	15	266	18.8	0.084
S5KP10A	11.1	12.3	5.0	10	15	294	17.0	0.084
S5KP11	12.2	14.9	5.0	11	10	249	20.1	0.086
S5KP11A	12.2	13.5	5.0	11	10	274	18.2	0.086
S5KP12	13.3	16.3	5.0	12	10	227	22.0	0.088
S5KP12A	13.3	14.7	5.0	12	10	251	19.9	0.088
S5KP13	14.4	17.6	5.0	13	10	210	23.8	0.090
S5KP13A	14.4	15.9	5.0	13	10	232	21.5	0.090
S5KP14	15.6	19.1	5.0	14	10	194	25.8	0.092
S5KP14A	15.6	17.2	5.0	14	10	215	23.2	0.092
S5KP15	16.7	20.4	5.0	15	10	188	26.9	0.094
S5KP15A	16.7	18.5	5.0	15	10	206	24.4	0.094
S5KP16	17.8	21.8	5.0	16	10	176	28.8	0.096
S5KP16A	17.8	19.7	5.0	16	10	192	26.0	0.096
S5KP17	18.9	23.1	5.0	17	10	164	30.5	0.097
S5KP17A	18.9	20.9	5.0	17	10	181	27.6	0.097
S5KP18	20.0	24.4	5.0	18	10	155	32.2	0.098
S5KP18A	20.0	22.1	5.0	18	10	172	29.2	0.098
S5KP20	22.2	27.1	5.0	20	10	139	35.8	0.099
S5KP20A	22.2	24.5	5.0	20	10	154	32.4	0.099
S5KP22	24.4	29.8	5.0	22	10	127	39.4	0.100
S5KP22A	24.4	26.9	5.0	22	10	141	35.5	0.100
S5KP24	26.7	32.6	5.0	24	10	116	43.0	0.101
S5KP24A	26.7	29.5	5.0	24	10	128	38.9	0.101
S5KP26	28.9	35.3	5.0	26	10	107	46.6	0.101
S5KP26A	28.9	31.9	5.0	26	10	119	42.1	0.101
S5KP28	31.1	38.0	5.0	28	10	99	50.1	0.102
S5KP28A	31.1	34.4	5.0	28	10	110	45.4	0.102
S5KP30	33.3	40.7	5.0	30	10	93	53.5	0.103
S5KP30A	33.3	36.8	5.0	30	10	103	48.4	0.103
S5KP33	36.7	44.9	5.0	33	10	85	59.0	0.104
S5KP33A	36.7	40.6	5.0	33	10	94	53.3	0.104
S5KP36	40.0	48.9	5.0	36	10	78	64.3	0.104
S5KP36A	40.0	44.2	5.0	36	10	86	58.1	0.104
S5KP40	44.4	54.3	5.0	40	10	70	71.4	0.105
S5KP40A	44.4	49.1	5.0	40	10	78	64.5	0.105
S5KP43	47.8	58.4	5.0	43	10	65	76.7	0.105
S5KP43A	47.8	52.8	5.0	43	10	72	69.4	0.105



Transient Voltage Suppressor Diodes

The plastic material carries U/L recognition 94V-O.

Type No.	Breakdown Voltage @ I_T (Note 1)		Reverse Stand off Voltage	Maximum Reverse Leakage @ V_{RM}	Maximum Peak Pulse Current (Note2)	Maximum Clamping Voltage @ I_{PPM}	Maximum Temperature Coefficient of V_{BR} (%/°C)
	V_{BR} (V)	I_T					
Unidirectional	Min.	Max.	(mA)	V_{RM} (V)	I_R (μ A)	I_{PPM} (A)	V_C (V)

S5KP Series, 5,000W, Case Type: D²PAK



S5KP45	50.0	61.1	5.0	45	10	62	80.3	0.106
S5KP45A	50.0	55.3	5.0	45	10	69	72.7	0.106
S5KP48	53.3	65.2	5.0	48	10	58	85.5	0.106
S5KP48A	53.3	58.9	5.0	48	10	65	77.4	0.106
S5KP51	56.7	69.3	5.0	51	10	55	91.1	0.107
S5KP51A	56.7	62.7	5.0	51	10	61	82.4	0.107
S5KP54	60.0	73.3	5.0	54	10	52	96.3	0.107
S5KP54A	60.0	66.3	5.0	54	10	57	87.1	0.107
S5KP56	62.2	76.1	5.0	56	10	50	100	0.107
S5KP56A	62.2	68.8	5.0	56	10	55	91	0.107
S5KP58	64.4	78.7	5.0	58	10	49	103	0.107
S5KP58A	64.4	71.2	5.0	58	10	53	94	0.107
S5KP60	66.7	81.5	5.0	60	10	47	107	0.108
S5KP60A	66.7	73.7	5.0	60	10	52	97	0.108
S5KP64	71.1	96.9	5.0	64	10	44	114	0.108
S5KP64A	71.1	78.6	5.0	64	10	49	103	0.108
S5KP70	77.6	95.1	5.0	70	10	40	125	0.108
S5KP70A	77.6	86.0	5.0	70	10	44	113	0.108
S5KP75	83.3	102	5.0	75	10	37	134	0.108
S5KP75A	83.3	92.1	5.0	75	10	41	121	0.108
S5KP78	86.7	106	5.0	78	10	36	139	0.108
S5KP78A	86.7	95.8	5.0	78	10	40	126	0.108
S5KP85	94.4	115	5.0	85	10	33	151	0.108
S5KP85A	94.4	104	5.0	85	10	36	137	0.110
S5KP90	100	122	5.0	90	10	31	160	0.110
S5KP90A	100	111	5.0	90	10	34	146	0.110
S5KP100	111	136	5.0	100	10	28	179	0.110
S5KP100A	111	123	5.0	100	10	31	162	0.110
S5KP110	122	149	5.0	110	10	26	196	0.112
S5KP110A	122	135	5.0	110	10	28	177	0.112
S5KP120	133	163	5.0	120	10	24	211	0.112
S5KP120A	133	147	5.0	120	10	26	192	0.112
S5KP150	167	204	5.0	150	10	19	263	0.112
S5KP150A	167	184	5.0	150	10	21	238	0.112
S5KP160	178	217	5.0	160	10	18	281	0.114
S5KP160A	178	196	5.0	160	10	19	263	0.114
S5KP170	189	231	5.0	170	10	17	298	0.114
S5KP170A	189	209	5.0	170	10	18	278	0.114
S5KP180	200	244	5.0	180	10	16	316	0.114
S5KP180A	200	221	5.0	180	10	17	290	0.114

Notes:

- (1) V_{BR} measured after I_T applied for 300 μ s., I_T = square wave pulse or equivalent
- (2) For bidirectional use suffix "C" or "CA"
- (3) V_F = 3.5 V max. for devices of V_R < 100 V, and V_F = 5 V max. for devices of V_R > 100 V
- (4) For bidirectional devices having V_R of 10 V and under, the I_R limit is doubled
- (5) "S KP " will be omitted on marking of the diode



Transient Voltage Suppressor Diodes

The plastic material carries U/L recognition 94V-O.

Type No.	Breakdown Voltage @ I_T		Reverse Stand off Voltage	Maximum Reverse Leakage @ V_{RWM}	Maximum Reverse Leakage @ V_{RM}	Maximum Peak Pulse Current at 10/1000ms	Maximum Clamping Voltage @ I_{PPM}	
	V_{BR} (V)	I_T	V_{RWM}	I_R	$I_R (T_C=175^\circ C)$	I_{PPM}	V_C	
Unidirectional	Min.	Max.	(mA)	(V)	(mA)	(mA)	(A)	(V)

SM8S Series, 6,600W, Case Type: D²PAK



SM8S10	11.1	13.6	5.0	10	15	250	351	18.8
SM8S10A	11.1	12.3	5.0	10	15	250	388	17.0
SM8S11	12.2	14.9	5.0	11	10	150	328	20.1
SM8S11A	12.2	13.5	5.0	11	10	150	363	18.2
SM8S12	13.3	16.3	5.0	12	10	150	300	22.0
SM8S12A	13.3	14.7	5.0	12	10	150	332	19.9
SM8S13	14.4	17.6	5.0	13	10	150	277	23.8
SM8S13A	14.4	15.9	5.0	13	10	150	307	21.5
SM8S14	15.6	19.1	5.0	14	10	150	256	25.8
SM8S14A	15.6	17.2	5.0	14	10	150	284	23.2
SM8S15	16.7	20.4	5.0	15	10	150	245	26.9
SM8S15A	16.7	18.5	5.0	15	10	150	270	24.4
SM8S16	17.8	21.8	5.0	16	10	150	229	28.8
SM8S16A	17.8	19.7	5.0	16	10	150	254	26.0
SM8S17	18.9	23.1	5.0	17	10	150	216	30.5
SM8S17A	18.9	20.9	5.0	17	10	150	239	27.6
SM8S18	20.0	24.4	5.0	18	10	150	205	32.2
SM8S18A	20.0	22.1	5.0	18	10	150	226	29.2
SM8S20	22.2	27.1	5.0	20	10	150	184	35.8
SM8S20A	22.2	24.5	5.0	20	10	150	204	32.4
SM8S22	24.4	29.8	5.0	22	10	150	168	39.4
SM8S22A	24.4	26.9	5.0	22	10	150	168	35.5
SM8S24	26.7	32.6	5.0	24	10	150	153	43.0
SM8S24A	26.7	29.5	5.0	24	10	150	170	38.9
SM8S26	28.9	35.3	5.0	26	10	150	142	46.6
SM8S26A	28.9	31.9	5.0	26	10	150	157	42.1
SM8S28	31.1	38.0	5.0	28	10	150	132	50.1
SM8S28A	31.1	34.4	5.0	28	10	150	145	45.4
SM8S30	33.3	40.7	5.0	30	10	150	123	53.5
SM8S30A	33.3	36.8	5.0	30	10	150	136	48.4
SM8S33	36.7	44.9	5.0	33	10	150	112	59.0
SM8S33A	36.7	40.6	5.0	33	10	150	124	53.3
SM8S36	40.0	48.9	5.0	36	10	150	103	64.3
SM8S36A	40.0	44.2	5.0	36	10	150	114	58.1
SM8S40	44.4	54.3	5.0	40	10	150	92	71.4
SM8S40A	44.4	49.1	5.0	40	10	150	102	64.5
SM8S43	47.8	58.4	5.0	43	10	150	86	76.7
SM8S43A	47.8	52.8	5.0	43	10	150	95	69.4

Notes:

- (1) For all types maximum $V_F = 1.8V$ at $I_F = 100A$ measured on 8.3ms single half sine-wave or equivalent square wave, duty cycle = 4 pulses per minute maximum
- (2) "SM S " will be omitted on marking of the diode.
- (3) For bidirectional use suffix "C" or "CA"



Transient Voltage Suppressor Diodes

The plastic material carries U/L recognition 94V-O.

Type No.		Reverse Stand Off Voltage V_R (V)	Breakdown Voltage @ I_T		Maximum Reverse Leakage @ V_R I_R (μ A)	Maximum Clamping Voltage @ I_{PP} V_C (V)	Maximum Peak Pulse Current I_{PP} (A)	Max. Voltage Temperature Variation of V_{BR} (mV/ $^{\circ}$ C)
(Unidirectional)	(Bidirectional)		V_{BR} (V) Min.	I_T (mA)				

15KP Series, 15,000 W, Case Type: D6



15KP17	15KP17C	17	18.9	50	5,000	32.2	464	19
15KP17A	15KP17CA	17	18.9	50	5,000	29.3	512	17
15KP18	15KP18C	18	20.0	50	5,000	34.2	439	20
15KP18A	15KP18CA	18	20.0	50	5,000	30.9	485	18
15KP20	15KP20C	20	22.2	20	1,500	37.9	396	24
15KP20A	15KP20CA	20	22.2	20	1,500	34.3	437	21
15KP22	15KP22C	22	24.4	10	500	41.1	365	27
15KP22A	15KP22CA	22	24.4	10	500	37.1	404	24
15KP24	15KP24C	24	26.7	5.0	150	45.0	333	30
15KP24A	15KP24CA	24	26.7	5.0	150	40.7	369	27
15KP26	15KP26C	26	28.9	5.0	50	48.7	308	32
15KP26A	15KP26CA	26	28.9	5.0	50	44.0	341	29
15KP28	15KP28C	28	31.1	5.0	25	52.4	286	35
15KP28A	15KP28CA	28	31.1	5.0	25	47.5	316	31
15KP30	15KP30C	30	33.3	5.0	15	56.2	267	37
15KP30A	15KP30CA	30	33.3	5.0	15	50.7	296	33
15KP33	15KP33C	33	36.7	5.0	10	60.6	248	42
15KP33A	15KP33CA	33	36.7	5.0	10	54.8	274	38
15KP36	15KP36C	36	40.0	5.0	10	66.0	227	46
15KP36A	15KP36CA	36	40.0	5.0	10	59.7	251	41
15KP40	15KP40C	40	44.4	5.0	10	72.8	206	51
15KP40A	15KP40CA	40	44.4	5.0	10	65.8	228	46
15KP43	15KP43C	43	47.8	5.0	10	77.1	195	55
15KP43A	15KP43CA	43	47.8	5.0	10	69.7	215	50
15KP45	15KP45C	45	50.0	5.0	10	80.7	186	57
15KP45A	15KP45CA	45	50.0	5.0	10	73.0	205	52
15KP48	15KP48C	48	53.3	5.0	10	85.9	175	62
15KP48A	15KP48CA	48	53.3	5.0	10	77.7	193	56
15KP51	15KP51C	51	56.7	5.0	10	91.5	164	66
15KP51A	15KP51CA	51	56.7	5.0	10	82.5	181	60
15KP54	15KP54C	54	60.0	5.0	10	96.8	155	70
15KP54A	15KP54CA	54	60.0	5.0	10	87.5	171	63
15KP58	15KP58C	58	64.4	5.0	10	104	144	76
15KP58A	15KP58CA	58	64.4	5.0	10	94	160	68
15KP60	15KP60C	60	66.7	5.0	10	107	140	78
15KP60A	15KP60CA	60	66.7	5.0	10	97.3	154	70
15KP64	15KP64C	64	71.1	5.0	10	115	130	84
15KP64A	15KP64CA	64	71.1	5.0	10	104	144	76
15KP70	15KP70C	70	77.8	5.0	10	126	119	92
15KP70A	15KP70CA	70	77.8	5.0	10	114	132	83
15KP75	15KP75C	75	83.3	5.0	10	135	111	100
15KP75A	15KP75CA	75	83.3	5.0	10	122	123	89



Transient Voltage Suppressor Diodes

The plastic material carries U/L recognition 94V-O.

Type No.		Reverse Stand Off Voltage V_R (V)	Breakdown Voltage @ I_T		Maximum Reverse Leakage @ V_R I_R (μA)	Maximum Clamping Voltage @ I_{PP} V_C (V)	Maximum Peak Pulse Current I_{PP} (A)	Max. Voltage Temperature Variation of V_{BR} (mV/ $^{\circ}C$)
(Unidirectional)	(Bidirectional)		V_{BR} (V) Min.	I_T (mA)				

15KP Series, 15,000 W, Case Type: D6



15KP78	15KP78C	78	86.7	5.0	10	140	107	104
15KP78A	15KP78CA	78	86.7	5.0	10	126	119	93
15KP85	15KP85C	85	94.4	5.0	10	152	99	113
15KP85A	15KP85CA	85	94.4	5.0	10	137	109	102
15KP90	15KP90C	90	100	5.0	10	160	94	120
15KP90A	15KP90CA	90	100	5.0	10	146	103	110
15KP100	15KP100C	100	111	5.0	10	179	84	134
15KP100A	15KP100CA	100	111	5.0	10	162	93	123
15KP110	15KP110C	110	122	5.0	10	196	77	147
15KP110A	15KP110CA	110	122	5.0	10	178	84	133
15KP120	15KP120C	120	133	5.0	10	214	70	161
15KP120A	15KP120CA	120	133	5.0	10	193	78	146
15KP130	15KP130C	130	144	5.0	10	231	65	174
15KP130A	15KP130CA	130	144	5.0	10	209	72	158
15KP150	15KP150C	150	167	5.0	10	268	56	202
15KP150A	15KP150CA	150	167	5.0	10	243	62	184
15KP160	15KP160C	160	178	5.0	10	287	52	216
15KP160A	15KP160CA	160	178	5.0	10	259	58	196
15KP170	15KP170C	170	189	5.0	10	304	49	229
15KP170A	15KP170CA	170	189	5.0	10	275	55	208
15KP180	15KP180C	180	200	5.0	10	321	47	242
15KP180A	15KP180CA	180	200	5.0	10	287	52	220
15KP200	15KP200C	200	222	5.0	10	356	42	296
15KP200A	15KP200CA	200	222	5.0	10	325	46	274
15KP220	15KP220C	220	245	5.0	10	393	38	297
15KP220A	15KP220CA	220	245	5.0	10	347	43	273
15KP240	15KP240C	240	267	5.0	10	428	35	324
15KP240A	15KP240CA	240	267	5.0	10	387	39	300

Note:

Suffix "A" denotes 5% tolerance device , no suffix denotes a 10% tolerance device



Transient Voltage Suppressor Diodes

The plastic material carries U/L recognition 94V-O.

Type No.		Reverse Stand Off Voltage	Breakdown Voltage @ $I_{(BR)}$			Maximum Reverse Leakage @ V_{WM}	Maximum Clamping Voltage @ I_{PP}	Maximum Peak Pulse Current	Max. Voltage Variation of V_{BR} Temperature
(Unidirectional)	(Bidirectional)	V_{WM} (V)	V_{BR} (V)		$I_{(BR)}$ (mA)	I_R (μ A)	V_C (V)	I_{PP} (A)	of V_{BR} (mV/ $^{\circ}$ C)
			Min.	Max.					

30KP Series, 30,000 W, Case Type: D6



30KP22	30KP22C	22	24.4	29.8	50	10000	41.1	730	27
30KP22A	30KP22CA	22	24.4	26.9	50	10000	37.1	808	24
30KP24	30KP24C	24	26.7	32.6	50	10000	45.0	666	30
30KP24A	30KP24CA	24	26.7	29.5	50	10000	40.7	738	27
30KP26	30KP26C	26	28.9	35.3	50	10000	48.7	616	32
30KP26A	30KP26CA	26	28.9	31.9	50	10000	44.0	682	29
30KP28	30KP28C	28	31.1	38.0	50	8000	52.4	572	35
30KP28A	30KP28CA	28	31.1	34.4	50	8000	47.5	632	31
30KP30	30KP30C	30	33.3	40.7	50	8000	56.2	534	37
30KP30A	30KP30CA	30	33.3	36.9	50	8000	50.7	592	33
30KP33	30KP33C	33	36.7	44.9	50	5000	64.6	496	42
30KP33A	30KP33CA	33	36.7	40.6	50	5000	58.6	548	38
30KP36	30KP36C	36	40.0	48.9	50	5000	68.2	454	46
30KP36A	30KP36CA	36	40.0	44.2	50	5000	61.8	502	41
30KP40	30KP40C	40	44.4	54.3	20	1500	75.8	412	51
30KP40A	30KP40CA	40	44.4	49.1	20	1500	68.6	456	46
30KP43	30KP43C	43	47.8	58.4	10	500	79.0	380	55
30KP43A	30KP43CA	43	47.8	52.8	10	500	71.0	430	50
30KP45	30KP45C	45	50.0	61.1	5	150	80.7	372	57
30KP45A	30KP45CA	45	50.0	55.3	5	150	73.0	410	52
30KP48	30KP48C	48	53.3	65.1	5	150	85.9	350	62
30KP48A	30KP48CA	48	53.3	58.9	5	150	77.7	386	56
30KP51	30KP51C	51	56.7	69.3	5	50	91.5	328	66
30KP51A	30KP51CA	51	56.7	62.7	5	50	82.8	362	60
30KP54	30KP54C	54	60.0	73.3	5	25	96.8	310	70
30KP54A	30KP54CA	54	60.0	66.3	5	25	87.5	342	63
30KP58	30KP58C	58	64.4	78.7	5	15	104	288	76
30KP58A	30KP58CA	58	64.4	71.2	5	15	94	320	68
30KP60	30KP60C	60	66.7	81.5	5	15	107	280	78
30KP60A	30KP60CA	60	66.7	73.7	5	15	97.3	304	71
30KP64	30KP64C	64	71.1	86.9	5	10	115	260	84
30KP64A	30KP64CA	64	71.1	78.6	5	10	104	288	76
30KP70	30KP70C	70	77.8	95.1	5	10	126	238	92
30KP70A	30KP70CA	70	77.8	86.0	5	10	114	264	83
30KP75	30KP75C	75	83.3	102	5	10	135	222	100
30KP75A	30KP75CA	75	83.3	92.1	5	10	122	246	89
30KP78	30KP78C	78	86.7	106	5	10	140	214	104
30KP78A	30KP78CA	78	86.7	95.8	5	10	126	238	93
30KP85	30KP85C	85	94.4	115	5	10	152	198	113
30KP85A	30KP85CA	85	94.4	104	5	10	137	218	102
30KP90	30KP90C	90	100	122	5	10	160	188	120
30KP90A	30KP90CA	90	100	111	5	10	146	206	109



Transient Voltage Suppressor Diodes

The plastic material carries U/L recognition 94V-O.

Type No.		Reverse Stand Off Voltage	Breakdown Voltage @ $I_{(BR)}$			Maximum Reverse Leakage @ V_{WM}	Maximum Clamping Voltage @ I_{PP}	Maximum Peak Pulse Current	Max. Voltage Temperature Variation of V_{BR}
(Unidirectional)	(Bidirectional)		V_{WM} (V)	V_{BR} (V)					
			Min.	Max.	$I_{(BR)}$ (mA)				

30KP Series, 30,000 W, Case Type: D6



30KP100	30KP100C	100	111	136	5	10	179	168	134
30KP100A	30KP100CA	100	111	123	5	10	162	186	121
30KP110	30KP110C	110	122	149	5	10	196	154	147
30KP110A	30KP110CA	110	122	135	5	10	178	168	133
30KP120	30KP120C	120	133	163	5	10	214	140	161
30KP120A	30KP120CA	120	133	147	5	10	193	156	145
30KP130	30KP130C	130	144	176	5	10	231	130	174
30KP130A	30KP130CA	130	144	159	5	10	209	142	157
30KP150	30KP150C	150	167	204	5	10	268	112	202
30KP150A	30KP150CA	150	167	185	5	10	243	124	183
30KP160	30KP160C	160	178	218	5	10	287	104	216
30KP160A	30KP160CA	160	178	197	5	10	259	116	195
30KP170	30KP170C	170	189	231	5	10	304	98	229
30KP170A	30KP170CA	170	189	209	5	10	275	110	207
30KP180	30KP180C	180	200	244	5	10	321	94	242
30KP180A	30KP180CA	180	200	221	5	10	291	104	219
30KP200	30KP200C	200	222	271	5	10	356	84	269
30KP200A	30KP200CA	200	222	245	5	10	322	94	243
30KP220	30KP220C	220	245	299	5	10	393	76	297
30KP220A	30KP220CA	220	245	271	5	10	356	84	269
30KP250A	30KP250CA	250	278	308	5	10	403	74	306
30KP260A	30KP260CA	260	289	320	5	10	419	71	318
30KP280A	30KP280CA	280	311	345	5	10	451	66	344
30KP300A	30KP300CA	300	333	369	5	10	483	62	368
30KP350A	30KP350CA	350	389	431	5	10	564	53	430
30KP400A	30KP400CA	400	444	492	5	10	644	46	490

Note:

Suffix "A" denotes 5% tolerance device , no suffix denotes a 10% tolerance device



Low Capacitance Transient Voltage Suppressor Diodes

The plastic material carries U/L recognition 94V-O.

Type No.	Breakdown Voltage @ It		Reverse Stand-off Voltage	Max. Reverse Leakage @ V_{RWM}	Max. Clamping Voltage @ $I_{RSM} = 5A$	Max. Reverse Current	Max. Junction Capacitance @ 0 Volt	Working Inverse Blocking Voltage	Max. Inverse Blocking Current @ V_{WIB}	Peak Inverse Blocking Voltage
	V_{BR} (V)	It								
	Min.	(mA)	(V)	(μA)	(V)	(A)	pF	(V)	mA	(V)

SAC Series, 500 W, Case Type: DO-41



SAC5.0	7.6	1.0	5.0	300	10.0	44	50	75	1.0	100
SAC6.0	7.9	1.0	6.0	300	11.2	41	50	75	1.0	100
SAC7.0	8.3	1.0	7.0	300	12.6	38	50	75	1.0	100
SAC8.0	8.9	1.0	8.0	100	13.4	36	50	75	1.0	100
SAC8.5	9.4	1.0	8.5	50	14.0	34	50	75	1.0	100
SAC10	11.1	1.0	10	5.0	16.3	29	50	75	1.0	100
SAC12	13.3	1.0	12	5.0	19.0	25	50	75	1.0	100
SAC15	16.7	1.0	15	5.0	23.6	20	50	75	1.0	100
SAC18	20.0	1.0	18	5.0	28.8	15	50	75	1.0	100
SAC22	24.4	1.0	22	5.0	35.4	14	50	75	1.0	100
SAC26	28.9	1.0	26	5.0	42.3	11.1	50	75	1.0	100
SAC30	33.3	1.0	30	5.0	48.6	10	50	75	1.0	100
SAC36	40.0	1.0	36	5.0	60.0	8.6	50	75	1.0	100
SAC45	50.0	1.0	45	5.0	77.0	6.8	50	150	1.0	200
SAC50	55.5	1.0	50	5.0	88.0	5.8	50	150	1.0	200



Low Capacitance Transient Voltage Suppressor Diodes

The plastic material carries U/L recognition 94V-O.

Type No.	Breakdown Voltage ⁽¹⁾ @ I _T		Reverse Stand-off Voltage	Maximum Reverse Leakage @ V _{RWM}	Maximum Peak Pulse Surge Current	Maximum Clamping Voltage @ I _{PPM}	Maximum Junction Capacitance @ 0 Volt
	V _{BR} (V)	I _T (mA)					
	Min.	Max.					pF

SMBJ-LC Series, 600 W, Case Type: SMB



SMBJ-LC5.0	7.20	8.62	10	5.0	800	62.5	9.6	80
SMBJ-LC5.0A	7.20	7.87	10	5.0	800	65.2	9.2	80
SMBJ-LC6.0	7.47	8.95	10	6.0	800	52.6	11.4	80
SMBJ-LC6.0A	7.47	8.17	10	6.0	800	58.3	10.3	80
SMBJ-LC6.5	8.02	9.62	10	6.5	500	48.7	12.3	80
SMBJ-LC6.5A	8.02	8.78	10	6.5	500	53.6	11.2	80
SMBJ-LC7.0	8.58	10.31	10	7.0	200	45.1	13.3	80
SMBJ-LC7.0A	8.58	9.40	10	7.0	200	50.0	12.0	80
SMBJ-LC7.5	9.13	11.00	1.0	7.5	100	42.0	14.3	80
SMBJ-LC7.5A	9.13	10.01	1.0	7.5	100	46.5	12.9	80
SMBJ-LC8.0	9.69	11.70	1.0	8.0	50	40.0	15.0	80
SMBJ-LC8.0A	9.69	10.63	1.0	8.0	50	44.1	13.6	80
SMBJ-LC8.5	10.24	12.3	1.0	8.5	10	37.7	15.9	80
SMBJ-LC8.5A	10.24	11.2	1.0	8.5	10	41.7	14.4	80
SMBJ-LC9.0	10.8	13.0	1.0	9.0	5.0	35.5	16.9	80
SMBJ-LC9.0A	10.8	11.9	1.0	9.0	5.0	39.0	15.4	80
SMBJ-LC10	11.9	14.4	1.0	10	1.0	31.9	18.8	80
SMBJ-LC10A	11.9	13.1	1.0	10	1.0	35.3	17.0	80
SMBJ-LC11	13.0	15.7	1.0	11	1.0	29.9	20.1	80
SMBJ-LC11A	13.0	14.3	1.0	11	1.0	33.0	18.2	80
SMBJ-LC12	14.1	17.1	1.0	12	1.0	27.3	22.0	80
SMBJ-LC12A	14.1	15.5	1.0	12	1.0	30.2	19.9	80
SMBJ-LC13	15.2	18.4	1.0	13	1.0	25.2	23.8	80
SMBJ-LC13A	15.2	16.7	1.0	13	1.0	27.9	21.5	80
SMBJ-LC14	16.4	19.9	1.0	14	1.0	23.3	25.8	80
SMBJ-LC14A	16.4	18.0	1.0	14	1.0	25.8	23.2	80
SMBJ-LC15	17.5	21.2	1.0	15	1.0	22.3	26.9	80
SMBJ-LC15A	17.5	19.3	1.0	15	1.0	24.0	24.4	80
SMBJ-LC16	18.6	22.6	1.0	16	1.0	20.8	28.8	80
SMBJ-LC16A	18.6	20.5	1.0	16	1.0	23.1	26.0	80
SMBJ-LC17	19.7	23.9	1.0	17	1.0	19.7	30.5	80
SMBJ-LC17A	19.7	21.7	1.0	17	1.0	21.7	27.6	80
SMBJ-LC18	20.8	25.2	1.0	18	1.0	18.6	32.2	80
SMBJ-LC18A	20.8	22.9	1.0	18	1.0	20.5	29.2	80
SMBJ-LC20	23.0	27.9	1.0	20	1.0	16.7	35.8	80
SMBJ-LC20A	23.0	25.3	1.0	20	1.0	18.5	32.4	80
SMBJ-LC22	25.2	30.6	1.0	22	1.0	15.2	39.4	80
SMBJ-LC22A	25.2	27.7	1.0	22	1.0	16.9	35.5	80
SMBJ-LC24	27.5	33.4	1.0	24	1.0	14.0	43.0	80
SMBJ-LC24A	27.5	30.3	1.0	24	1.0	15.4	38.9	80
SMBJ-LC26	29.7	36.1	1.0	26	1.0	12.4	46.6	80
SMBJ-LC26A	29.7	32.7	1.0	26	1.0	14.2	42.1	80
SMBJ-LC28	31.9	38.8	1.0	28	1.0	12.0	50.0	80
SMBJ-LC28A	31.9	35.2	1.0	28	1.0	13.2	45.4	80
SMBJ-LC30	34.1	41.5	1.0	30	1.0	11.2	53.5	80
SMBJ-LC30A	34.1	37.6	1.0	30	1.0	12.4	48.4	80
SMBJ-LC33	37.5	45.7	1.0	33	1.0	10.2	59.0	80
SMBJ-LC33A	37.5	41.4	1.0	33	1.0	11.3	53.3	80



Low Capacitance Transient Voltage Suppressor Diodes

The plastic material carries U/L recognition 94V-O.

Type No.	Breakdown Voltage ⁽¹⁾ @ I _T		Reverse Stand-off Voltage	Maximum Reverse Leakage @ V _{RWM}	Maximum Peak Pulse Surge Current	Maximum Clamping Voltage @ I _{PPM}	Maximum Junction Capacitance @ 0 Volt
	V _{BR} (V)	I _T (mA)					
	Min.	Max.					pF

SMBJ-LC Series, 600 W, Case Type: SMB



SMBJ-LC36	40.8	49.7	1.0	36	1.0	9.3	64.3	80
SMBJ-LC36A	40.8	45.0	1.0	36	1.0	10.3	58.1	80
SMBJ-LC40	45.2	55.1	1.0	40	1.0	8.4	71.4	80
SMBJ-LC40A	45.2	49.9	1.0	40	1.0	9.3	64.5	80
SMBJ-LC43	48.6	59.2	1.0	43	1.0	7.8	76.7	80
SMBJ-LC43A	48.6	53.6	1.0	43	1.0	8.6	69.4	80
SMBJ-LC45	50.8	61.9	1.0	45	1.0	7.5	80.3	80
SMBJ-LC45A	50.8	56.1	1.0	45	1.0	8.3	72.7	80
SMBJ-LC48	54.1	65.9	1.0	48	1.0	7.0	85.5	80
SMBJ-LC48A	54.1	59.7	1.0	48	1.0	7.7	77.4	80
SMBJ-LC51	57.5	70.1	1.0	51	1.0	6.6	91.1	80
SMBJ-LC51A	57.5	63.5	1.0	51	1.0	7.3	82.4	80
SMBJ-LC54	60.8	74.1	1.0	54	1.0	6.2	96.3	80
SMBJ-LC54A	60.8	67.1	1.0	54	1.0	6.9	87.1	80
SMBJ-LC58	65.2	79.5	1.0	58	1.0	5.8	103	80
SMBJ-LC58A	65.2	72.0	1.0	58	1.0	6.4	93.6	80
SMBJ-LC60	67.5	82.3	1.0	60	1.0	5.6	107	80
SMBJ-LC60A	67.5	74.5	1.0	60	1.0	6.2	96.8	80
SMBJ-LC64	71.9	87.7	1.0	64	1.0	5.3	114	80
SMBJ-LC64A	71.9	79.4	1.0	64	1.0	5.8	103	80
SMBJ-LC70	78.6	95.9	1.0	70	1.0	4.8	125	80
SMBJ-LC70A	78.6	86.8	1.0	70	1.0	5.3	113	80
SMBJ-LC75	84.1	102.8	1.0	75	1.0	4.5	134	80
SMBJ-LC75A	84.1	92.9	1.0	75	1.0	4.9	121	80
SMBJ-LC78	87.5	106.8	1.0	78	1.0	4.3	139	80
SMBJ-LC78A	87.5	96.6	1.0	78	1.0	4.7	126	80
SMBJ-LC85	95.2	115.8	1.0	85	1.0	3.9	151	80
SMBJ-LC85A	95.2	104.8	1.0	85	1.0	4.4	137	80
SMBJ-LC90	100.8	122.8	1.0	90	1.0	3.8	160	80
SMBJ-LC90A	100.8	111.8	1.0	90	1.0	4.1	146	80
SMBJ-LC100	111.8	136.8	1.0	100	1.0	3.4	179	80
SMBJ-LC100A	111.8	123.8	1.0	100	1.0	3.7	162	80
SMBJ-LC110	122.8	149.8	1.0	110	1.0	3.0	196	80
SMBJ-LC110A	122.8	135.8	1.0	110	1.0	3.4	177	80
SMBJ-LC120	133.8	163.8	1.0	120	1.0	2.8	214	80
SMBJ-LC120A	133.8	147.8	1.0	120	1.0	3.1	193	80
SMBJ-LC130	144.8	176.8	1.0	130	1.0	2.6	231	80
SMBJ-LC130A	144.8	159.8	1.0	130	1.0	2.9	209	80
SMBJ-LC150	167.8	204.8	1.0	150	1.0	2.2	268	80
SMBJ-LC150A	167.8	185.8	1.0	150	1.0	2.5	243	80
SMBJ-LC160	178.8	218.8	1.0	160	1.0	2.1	287	80
SMBJ-LC160A	178.8	197.8	1.0	160	1.0	2.3	259	80
SMBJ-LC170	189.8	231.8	1.0	170	1.0	2.0	304	80
SMBJ-LC170A	189.8	209.8	1.0	170	1.0	2.2	275	80
SMBJ-LC188	209.8	255.8	1.0	188	1.0	1.7	344	80
SMBJ-LC188A	209.8	231.8	1.0	188	1.0	2.0	328	80



Low Capacitance Transient Voltage Suppressor Diodes

The plastic material carries U/L recognition 94V-O.

Type No.	Breakdown Voltage @ It		Reverse Stand-off Voltage	Max. Reverse Leakage @ V_{RWM}	Max. Clamping Voltage @ I_{RSM}	Max. Reverse Current	Max. Junction Capacitance @ 0 Volt	Working Inverse Blocking Voltage	Max. Inverse Blocking Current @ V_{WIB}	Peak Inverse Blocking Voltage
	V_{BR} (V)	I_t								
	Min.	Max.	(mA)	(V)	(μ A)	(V)	(A)	pF	(V)	(mA)

LCE Series, 1500 W, Case Type: DO-201



LCE6.5	8.02	9.62	10	6.5	1000	14.3	100	100	75	1.0	100
LCE6.5A	8.02	8.78	10	6.5	1000	13.2	100	100	75	1.0	100
LCE7.0	8.58	10.31	10	7.0	500	15.3	100	100	75	1.0	100
LCE7.0A	8.58	9.40	10	7.0	500	14.0	100	100	75	1.0	100
LCE7.5	9.13	11.00	10	7.5	250	16.3	100	100	75	1.0	100
LCE7.5A	9.13	10.01	10	7.5	250	14.9	100	100	75	1.0	100
LCE8.0	9.69	11.70	10	8.0	100	17.0	100	100	75	1.0	100
LCE8.0A	9.69	10.63	10	8.0	100	15.6	100	100	75	1.0	100
LCE8.5	10.24	12.3	1.0	8.5	50	17.9	94	100	75	1.0	100
LCE8.5A	10.24	11.2	1.0	8.5	50	16.4	100	100	75	1.0	100
LCE9.0	10.8	13.0	1.0	9.0	10.0	18.9	89	100	75	1.0	100
LCE9.0A	10.8	11.9	1.0	9.0	10.0	17.4	97	100	75	1.0	100
LCE10	11.9	14.4	1.0	10	5.0	20.8	80	100	75	1.0	100
LCE10A	11.9	13.1	1.0	10	5.0	19.0	88	100	75	1.0	100
LCE11	13.0	15.7	1.0	11	5.0	22.1	74	100	75	1.0	100
LCE11A	13.0	14.3	1.0	11	5.0	20.2	82	100	75	1.0	100
LCE12	14.1	17.1	1.0	12	5.0	24.0	68	100	75	1.0	100
LCE12A	14.1	15.5	1.0	12	5.0	21.9	75	100	75	1.0	100
LCE13	15.2	18.4	1.0	13	5.0	25.8	63	100	75	1.0	100
LCE13A	15.2	16.7	1.0	13	5.0	23.5	70	100	75	1.0	100
LCE14	16.4	19.9	1.0	14	5.0	27.8	58	100	75	1.0	100
LCE14A	16.4	18.0	1.0	14	5.0	25.2	65	100	75	1.0	100
LCE15	17.5	21.2	1.0	15	5.0	28.9	56	100	75	1.0	100
LCE15A	17.5	19.3	1.0	15	5.0	26.4	61	100	75	1.0	100
LCE16	18.6	22.6	1.0	16	5.0	30.8	52	100	75	1.0	100
LCE16A	18.6	20.5	1.0	16	5.0	28.0	57	100	75	1.0	100
LCE17	19.7	23.9	1.0	17	5.0	32.5	49	100	75	1.0	100
LCE17A	19.7	21.7	1.0	17	5.0	29.6	54	100	75	1.0	100
LCE18	20.8	25.2	1.0	18	5.0	34.2	46	100	75	1.0	100
LCE18A	20.8	22.9	1.0	18	5.0	31.2	51	100	75	1.0	100
LCE20	23.0	27.9	1.0	20	5.0	37.8	42	100	75	1.0	100
LCE20A	23.0	25.3	1.0	20	5.0	34.4	46	100	75	1.0	100
LCE22	25.2	30.6	1.0	22	5.0	41.4	38	100	75	1.0	100
LCE22A	25.2	27.7	1.0	22	5.0	37.5	42	100	75	1.0	100
LCE24	27.5	33.4	1.0	24	5.0	45.0	35	100	75	1.0	100
LCE24A	27.5	30.3	1.0	24	5.0	40.9	39	100	75	1.0	100
LCE26	29.7	36.1	1.0	26	5.0	48.6	32	100	75	1.0	100
LCE26A	29.7	32.7	1.0	26	5.0	44.1	36	100	75	1.0	100



Low Capacitance Transient Voltage Suppressor Diodes

The plastic material carries U/L recognition 94V-O.

Type No.	Breakdown Voltage @ It		Reverse Stand-off Voltage	Max. Reverse Leakage @ V_{RWM}	Max. Clamping Voltage @ I_{RSM}	Max. Reverse Current	Max. Junction Capacitance @ 0 Volt	Working Inverse Blocking Voltage	Max. Inverse Blocking Current @ V_{WIB}	Peak Inverse Blocking Voltage
	V_{BR} (V)	I_t								
	Min.	Max.	(mA)	(V)	(μ A)	(V)	(A)	pF	(V)	(mA)

LCE Series, 1500 W, Case Type: DO-201



LCE28	31.9	38.8	1.0	28	5.0	52.1	30	100	75	1.0	100
LCE28A	31.9	35.2	1.0	28	5.0	47.5	33	100	75	1.0	100
LCE30	34.1	41.5	1.0	30	5.0	55.5	28	100	75	1.0	100
LCE30A	34.1	37.6	1.0	30	5.0	50.4	31	100	75	1.0	100
LCE33	37.5	45.7	1.0	33	5.0	61.0	25.4	100	75	1.0	100
LCE33A	37.5	41.4	1.0	33	5.0	55.3	28.1	100	75	1.0	100
LCE36	40.8	49.7	1.0	36	5.0	66.3	23.3	100	75	1.0	100
LCE36A	40.8	45.0	1.0	36	5.0	60.1	25.8	100	75	1.0	100
LCE40	45.2	55.1	1.0	40	5.0	73.4	21	100	75	1.0	100
LCE40A	45.2	49.9	1.0	40	5.0	66.5	23.3	100	75	1.0	100
LCE43	48.6	59.2	1.0	43	5.0	78.7	19.5	100	150	1.0	200
LCE43A	48.6	53.6	1.0	43	5.0	71.4	21.6	100	150	1.0	200
LCE45	50.8	61.9	1.0	45	5.0	82.3	18.7	100	150	1.0	200
LCE45A	50.8	56.1	1.0	45	5.0	74.7	20.6	100	150	1.0	200
LCE48	54.1	65.9	1.0	48	5.0	87.5	17.5	100	150	1.0	200
LCE48A	54.1	59.7	1.0	48	5.0	79.4	19.4	100	150	1.0	200
LCE51	57.5	70.1	1.0	51	5.0	93.1	16.5	100	150	1.0	200
LCE51A	57.5	63.5	1.0	51	5.0	84.4	18.2	100	150	1.0	200
LCE54	60.8	74.1	1.0	54	5.0	98.3	15.6	100	150	1.0	200
LCE54A	60.8	67.1	1.0	54	5.0	89.1	17.2	100	150	1.0	200
LCE58	65.2	79.5	1.0	58	5.0	105.0	14.6	100	150	1.0	200
LCE58A	65.2	72.0	1.0	58	5.0	95.6	16	100	150	1.0	200
LCE60	67.5	82.3	1.0	60	5.0	109.0	14	90	150	1.0	200
LCE60A	67.5	74.5	1.0	60	5.0	98.8	15.5	90	150	1.0	200
LCE64	71.9	87.7	1.0	64	5.0	116.0	13.2	90	150	1.0	200
LCE64A	71.9	79.4	1.0	64	5.0	105.0	14.6	90	150	1.0	200
LCE70	78.6	95.9	1.0	70	5.0	127.0	12.0	90	150	1.0	200
LCE70A	78.6	86.8	1.0	70	5.0	115.0	13.3	90	150	1.0	200
LCE75	84.1	102.8	1.0	75	5.0	136.0	11.2	90	150	1.0	200
LCE75A	84.1	92.9	1.0	75	5.0	123.0	12.4	90	150	1.0	200
LCE80	95.2	115.8	1.0	80	5.0	144.0	10.6	90	150	1.0	200
LCE80A	95.2	104.8	1.0	80	5.0	131.0	11.6	90	150	1.0	200
LCE90	100.8	122.8	1.0	90	5.0	162.0	9.4	90	300	1.0	200
LCE90A	100.8	111.8	1.0	90	5.0	148.0	10.3	90	300	1.0	200



Low Capacitance Transient Voltage Suppressor Diodes

The plastic material carries U/L recognition 94V-O.

Type Number	Reverse Stand-off Voltage	Breakdown Voltage @ $I_{(BR)}$			Maximum Reverse Leakage @ V_{WM}	Maximum Clamping Voltage @ I_{PP}	Maximum Peak Pulse Current @ 10/1000	Maximum Junction Capacitance @ 0 Volt	Working Inverse Blocking Voltage	Inverse Blocking Leakage Current	Peak Inverse Blocking Voltage
		V_{BR} (V)	$I_{(BR)}$	I_D							
	V_{WM} (V)	Min.	Max.	(mA)	(μ A)	(V)	(A)	pF	V_{WIB} (V)	I_{IB} mA	V_{PIB} (V)

SMCJLCE Series, 1500 W, Case Type: SMC



SMCJLCE6.5	6.5	7.22	8.82	10	1000	12.3	100	75	75	1.0	100
SMCJLCE6.5A	6.5	7.22	7.98	10	1000	11.2	100	75	75	1.0	100
SMCJLCE7.0	7.0	7.78	9.51	10	500	13.3	100	75	75	1.0	100
SMCJLCE7.0A	7.0	7.78	8.60	10	500	12.0	100	75	75	1.0	100
SMCJLCE7.5	7.5	8.33	10.2	10	250	14.3	100	100	75	1.0	100
SMCJLCE7.5A	7.5	8.33	9.21	10	250	12.9	100	100	75	1.0	100
SMCJLCE8.0	8.0	8.89	10.9	10	100	15.0	100	100	75	1.0	100
SMCJLCE8.0A	8.0	8.89	9.83	1.0	100	13.6	100	100	75	1.0	100
SMCJLCE8.5	8.5	9.44	11.5	1.0	50	15.9	94	100	75	1.0	100
SMCJLCE8.5A	8.5	9.44	10.4	1.0	50	14.4	100	100	75	1.0	100
SMCJLCE9.0	9.0	10.0	12.2	1.0	10	16.9	89	100	75	1.0	100
SMCJLCE9.0A	9.0	10.0	11.1	1.0	10	15.4	97	100	75	1.0	100
SMCJLCE10	10	11.1	13.6	1.0	5.0	18.8	80	100	75	1.0	100
SMCJLCE10A	10	11.1	12.3	1.0	5.0	17.0	88	100	75	1.0	100
SMCJLCE11	11	12.2	14.9	1.0	5.0	20.1	74	100	75	1.0	100
SMCJLCE11A	11	12.2	13.5	1.0	5.0	18.2	82	100	75	1.0	100
SMCJLCE12	12	13.3	16.3	1.0	5.0	22.0	68	100	75	1.0	100
SMCJLCE12A	12	13.3	14.7	1.0	5.0	19.9	75	100	75	1.0	100
SMCJLCE13	13	14.4	17.6	1.0	5.0	23.8	63	100	75	1.0	100
SMCJLCE13A	13	14.4	15.9	1.0	5.0	21.5	70	100	75	1.0	100
SMCJLCE14	14	15.6	19.1	1.0	5.0	25.8	58	100	75	1.0	100
SMCJLCE14A	14	15.6	17.2	1.0	5.0	23.2	65	100	75	1.0	100
SMCJLCE15	15	16.7	20.4	1.0	5.0	26.9	56	100	75	1.0	100
SMCJLCE15A	15	16.7	18.5	1.0	5.0	24.4	61	100	75	1.0	100
SMCJLCE16	16	17.8	21.8	1.0	5.0	28.8	52	100	75	1.0	100
SMCJLCE16A	16	17.8	19.7	1.0	5.0	26.0	57	100	75	1.0	100
SMCJLCE17	17	18.9	23.1	1.0	5.0	30.5	49	100	75	1.0	100
SMCJLCE17A	17	18.9	20.9	1.0	5.0	27.6	54	100	75	1.0	100
SMCJLCE18	18	20.0	24.4	1.0	5.0	32.2	46	100	75	1.0	100
SMCJLCE18A	18	20.0	22.1	1.0	5.0	29.2	51	100	75	1.0	100
SMCJLCE20	20	22.2	27.1	1.0	5.0	35.8	42	100	75	1.0	100
SMCJLCE20A	20	22.2	24.5	1.0	5.0	32.4	46	100	75	1.0	100
SMCJLCE22	22	24.4	29.8	1.0	5.0	39.4	38	100	75	1.0	100
SMCJLCE22A	22	24.4	26.9	1.0	5.0	35.5	42	100	75	1.0	100
SMCJLCE24	24	26.7	32.6	1.0	5.0	43.0	35	100	75	1.0	100
SMCJLCE24A	24	26.7	29.5	1.0	5.0	38.9	39	100	75	1.0	100
SMCJLCE26	26	28.9	35.3	1.0	5.0	46.6	32	100	75	1.0	100
SMCJLCE26A	26	28.9	31.9	1.0	5.0	42.1	36	100	75	1.0	100
SMCJLCE28	28	31.1	38.0	1.0	5.0	50.1	30	100	75	1.0	100
SMCJLCE28A	28	31.1	34.4	1.0	5.0	45.5	33	100	75	1.0	100
SMCJLCE30	30	33.3	40.7	1.0	5.0	53.5	28	100	75	1.0	100
SMCJLCE30A	30	33.3	36.8	1.0	5.0	48.4	31	100	75	1.0	100
SMCJLCE33	33	36.7	44.9	1.0	5.0	59.0	25.4	100	75	1.0	100
SMCJLCE33A	33	36.7	40.6	1.0	5.0	53.3	28.1	100	75	1.0	100



Low Capacitance Transient Voltage Suppressor Diodes

The plastic material carries U/L recognition 94V-O.

Type Number	Reverse Stand-off Voltage	Breakdown Voltage @ $I_{(BR)}$		Maximum Reverse Leakage @ V_{WM}	Maximum Clamping Voltage @ I_{PP}	Maximum Peak Pulse Current @ 10/1000	Maximum Junction Capacitance @ 0 Volt	Working Inverse Blocking Voltage	Inverse Blocking Leakage Current	Peak Inverse Blocking Voltage
		V_{BR} (V)	$I_{(BR)}$							
	V_{WM} (V)	Min.	Max.	$I_{(BR)}$ (mA)	I_D (μ A)	V_C (V)	I_{PP} (A)	pF	V_{WIB} (V)	I_{IB} (mA)

SMCJLCE Series, 1500 W, Case Type: SMC



SMCJLCE36	36	40.0	48.9	1.0	5.0	64.3	23.3	100	75	1.0	100
SMCJLCE36A	36	40.0	44.2	1.0	5.0	58.1	25.8	100	75	1.0	100
SMCJLCE40	40	44.4	54.3	1.0	5.0	71.4	21.0	100	75	1.0	100
SMCJLCE40A	40	44.4	49.1	1.0	5.0	64.5	23.3	100	75	1.0	100
SMCJLCE43	43	47.8	58.4	1.0	5.0	76.7	19.5	100	150	1.0	200
SMCJLCE43A	43	47.8	52.8	1.0	5.0	69.4	21.6	100	150	1.0	200
SMCJLCE45	45	50.0	61.1	1.0	5.0	80.3	18.7	100	150	1.0	200
SMCJLCE45A	45	50.0	55.3	1.0	5.0	72.7	20.6	100	150	1.0	200
SMCJLCE48	48	53.3	65.1	1.0	5.0	85.5	17.5	100	150	1.0	200
SMCJLCE48A	48	53.3	58.9	1.0	5.0	77.4	19.4	100	150	1.0	200
SMCJLCE51	51	56.7	69.3	1.0	5.0	91.1	16.5	100	150	1.0	200
SMCJLCE51A	51	56.7	62.7	1.0	5.0	82.4	18.2	100	150	1.0	200
SMCJLCE54	54	60.0	73.3	1.0	5.0	96.3	15.6	100	150	1.0	200
SMCJLCE54A	54	60.0	66.3	1.0	5.0	87.1	17.2	100	150	1.0	200
SMCJLCE58	58	64.4	78.7	1.0	5.0	103	14.6	100	150	1.0	200
SMCJLCE58A	58	64.4	71.2	1.0	5.0	93.6	16.0	100	150	1.0	200
SMCJLCE60	60	66.7	81.5	1.0	5.0	107	14.0	90	150	1.0	200
SMCJLCE60A	60	66.7	73.7	1.0	5.0	96.8	15.5	90	150	1.0	200
SMCJLCE64	64	71.1	86.9	1.0	5.0	114	13.2	90	150	1.0	200
SMCJLCE64A	64	71.1	78.6	1.0	5.0	103	14.6	90	150	1.0	200
SMCJLCE70	70	77.8	95.1	1.0	5.0	125	12.0	90	150	1.0	200
SMCJLCE70A	70	77.8	86.0	1.0	5.0	113	13.3	90	150	1.0	200
SMCJLCE75	75	83.3	102	1.0	5.0	134	11.2	90	150	1.0	200
SMCJLCE75A	75	83.3	92.1	1.0	5.0	121	12.4	90	150	1.0	200
SMCJLCE80	80	88.7	108	1.0	5.0	142	10.6	90	150	1.0	200
SMCJLCE80A	80	88.7	98.0	1.0	5.0	129	11.6	90	150	1.0	200
SMCJLCE90	90	100	122	1.0	5.0	160	9.4	90	300	1.0	200
SMCJLCE90A	90	100	111	1.0	5.0	146	10.3	90	300	1.0	200
SMCJLCE100	100	111	136	1.0	5.0	179	8.4	90	300	1.0	200
SMCJLCE100A	100	111	123	1.0	5.0	162	9.3	90	300	1.0	200
SMCJLCE110	110	122	149	1.0	5.0	196	7.7	90	300	1.0	400
SMCJLCE110A	110	122	135	1.0	5.0	178	8.4	90	300	1.0	400
SMCJLCE120	120	133	163	1.0	5.0	214	7.0	90	300	1.0	400
SMCJLCE120A	120	133	147	1.0	5.0	193	7.8	90	300	1.0	400
SMCJLCE130	130	144	176	1.0	5.0	231	6.5	90	300	1.0	400
SMCJLCE130A	130	144	159	1.0	5.0	209	7.2	90	300	1.0	400
SMCJLCE150	150	167	204	1.0	5.0	268	5.6	90	300	1.0	400
SMCJLCE150A	150	167	185	1.0	5.0	243	6.2	90	300	1.0	400
SMCJLCE160	160	178	218	1.0	5.0	287	5.2	90	300	1.0	400
SMCJLCE160A	160	178	197	1.0	5.0	259	5.8	90	300	1.0	400
SMCJLCE170	170	189	231	1.0	5.0	304	4.9	90	300	1.0	400
SMCJLCE170A	170	189	209	1.0	5.0	275	5.4	90	300	1.0	400



Ultra Low Capacitance Transient Voltage Suppressor Diodes

The plastic material carries U/L recognition 94V-O.

Type No.	Breakdown Voltage @ It		Reverse Stand-off Voltage	Max. Reverse Leakage @ VRWM	Max. Clamping Voltage @ IRSM	Max. Reverse Current	Max. Junction Capacitance @ 0 Volt	Working Inverse Blocking Voltage	Max. Inverse Blocking Current @ VWIB	Peak Inverse Blocking Voltage
	VBR (V)	It								
	Min.	Max.	(mA)	(V)	(μ A)	(V)	(A)	pF	(V)	(mA)

ULCE Series, 1500 W, Case Type: DO-201



ULCE6.5	10.42	12.02	10	6.5	1000	16.3	100	35	75	1.0	100
ULCE6.5A	10.42	11.8	10	6.5	1000	15.2	100	35	75	1.0	100
ULCE7.0	10.98	12.71	10	7.0	500	17.3	100	35	75	1.0	100
ULCE7.0A	10.98	11.80	10	7.0	500	16.0	100	35	75	1.0	100
ULCE7.5	11.53	13.40	10	7.5	250	18.3	100	35	75	1.0	100
ULCE7.5A	11.53	12.41	10	7.5	250	16.9	100	35	75	1.0	100
ULCE8.0	12.09	14.1	10	8.0	100	19.0	100	35	75	1.0	100
ULCE8.0A	12.09	13.03	10	8.0	100	17.6	100	35	75	1.0	100
ULCE8.5	12.64	14.7	1.0	8.5	50	19.9	94	35	75	1.0	100
ULCE8.5A	12.64	13.6	1.0	8.5	50	18.4	100	35	75	1.0	100
ULCE9.0	13.2	15.4	1.0	9.0	10.0	20.9	89	35	75	1.0	100
ULCE9.0A	13.2	14.3	1.0	9.0	10.0	19.4	97	35	75	1.0	100
ULCE10	14.3	16.8	1.0	10	5.0	22.8	80	35	75	1.0	100
ULCE10A	14.3	15.5	1.0	10	5.0	21.0	88	35	75	1.0	100
ULCE11	15.4	18.1	1.0	11	5.0	24.1	74	35	75	1.0	100
ULCE11A	15.4	16.7	1.0	11	5.0	22.2	82	35	75	1.0	100
ULCE12	16.5	19.5	1.0	12	5.0	26.0	68	35	75	1.0	100
ULCE12A	16.5	17.9	1.0	12	5.0	23.9	75	35	75	1.0	100
ULCE13	17.6	20.8	1.0	13	5.0	27.8	63	35	75	1.0	100
ULCE13A	17.6	19.1	1.0	13	5.0	25.5	70	35	75	1.0	100
ULCE14	18.8	22.3	1.0	14	5.0	29.8	58	35	75	1.0	100
ULCE14A	18.8	20.4	1.0	14	5.0	27.2	65	35	75	1.0	100
ULCE15	19.9	23.6	1.0	15	5.0	30.9	56	35	75	1.0	100
ULCE15A	19.9	21.7	1.0	15	5.0	28.4	61	35	75	1.0	100
ULCE16	21.0	25.0	1.0	16	5.0	32.8	52	35	75	1.0	100
ULCE16A	21.0	22.9	1.0	16	5.0	30.0	57	35	75	1.0	100
ULCE17	22.1	26.3	1.0	17	5.0	34.5	49	35	75	1.0	100
ULCE17A	22.1	24.1	1.0	17	5.0	31.6	54	35	75	1.0	100
ULCE18	23.2	27.6	1.0	18	5.0	36.2	46	35	75	1.0	100
ULCE18A	23.2	25.3	1.0	18	5.0	33.2	51	35	75	1.0	100
ULCE20	25.4	30.3	1.0	20	5.0	39.8	42	35	75	1.0	100
ULCE20A	25.4	27.7	1.0	20	5.0	36.4	46	35	75	1.0	100
ULCE22	27.6	33.0	1.0	22	5.0	43.4	38	35	75	1.0	100
ULCE22A	27.6	30.1	1.0	22	5.0	39.5	42	35	75	1.0	100
ULCE24	29.9	35.8	1.0	24	5.0	47.0	35	35	75	1.0	100
ULCE24A	29.9	32.7	1.0	24	5.0	42.9	39	35	75	1.0	100
ULCE26	32.1	38.5	1.0	26	5.0	50.6	32	35	75	1.0	100
ULCE26A	32.1	35.1	1.0	26	5.0	46.1	36	35	75	1.0	100



Ultra Low Capacitance Transient Voltage Suppressor Diodes

The plastic material carries U/L recognition 94V-O.

Type No.	Breakdown Voltage @ I_t		Reverse Stand-off Voltage	Max. Reverse Leakage @ V_{RWM}	Max. Clamping Voltage @ I_{RSM}	Max. Reverse Current	Max. Junction Capacitance @ 0 Volt	Working Inverse Blocking Voltage	Max. Inverse Blocking Current @ V_{WIB}	Peak Inverse Blocking Voltage
	V_{BR} (V)	I_t								
	Min.	Max.	(mA)	(V)	(μ A)	(V)	(A)	pF	(V)	(mA)

ULCE Series, 1500 W, Case Type: DO-201



ULCE28	34.3	41.2	1.0	28	5.0	54.1	30	35	75	1.0	100
ULCE28A	34.3	37.6	1.0	28	5.0	49.5	33	35	75	1.0	100
ULCE30	36.5	43.9	1.0	30	5.0	57.5	28	35	75	1.0	100
ULCE30A	36.5	40.0	1.0	30	5.0	52.4	31	35	75	1.0	100
ULCE33	39.9	48.1	1.0	33	5.0	63.0	25.4	35	75	1.0	100
ULCE33A	39.9	43.8	1.0	33	5.0	57.3	28.1	35	75	1.0	100
ULCE36	43.2	52.1	1.0	36	5.0	68.3	23.3	35	75	1.0	100
ULCE36A	43.2	47.4	1.0	36	5.0	62.1	25.8	35	75	1.0	100
ULCE40	47.6	57.5	1.0	40	5.0	75.4	21	35	75	1.0	100
ULCE40A	47.6	52.3	1.0	40	5.0	68.5	23.3	35	75	1.0	100
ULCE43	51.0	61.6	1.0	43	5.0	80.7	19.5	35	150	1.0	200
ULCE43A	51.0	56.0	1.0	43	5.0	73.4	21.6	35	150	1.0	200
ULCE45	53.2	64.3	1.0	45	5.0	84.3	18.7	35	150	1.0	200
ULCE45A	53.2	58.5	1.0	45	5.0	76.7	20.6	35	150	1.0	200
ULCE48	56.5	68.3	1.0	48	5.0	89.5	17.5	35	150	1.0	200
ULCE48A	56.5	62.1	1.0	48	5.0	81.4	19.4	35	150	1.0	200
ULCE51	59.9	72.5	1.0	51	5.0	95.1	16.5	35	150	1.0	200
ULCE51A	59.9	65.9	1.0	51	5.0	86.4	18.2	35	150	1.0	200
ULCE54	63.2	76.5	1.0	54	5.0	100.3	15.6	35	150	1.0	200
ULCE54A	63.2	69.5	1.0	54	5.0	91.1	17.2	35	150	1.0	200
ULCE58	67.6	81.9	1.0	58	5.0	107.0	14.6	35	150	1.0	200
ULCE58A	67.6	74.4	1.0	58	5.0	97.6	16	35	150	1.0	200
ULCE60	69.9	84.7	1.0	60	5.0	111.0	14	35	150	1.0	200
ULCE60A	69.9	76.9	1.0	60	5.0	100.8	15.5	35	150	1.0	200
ULCE64	74.3	90.1	1.0	64	5.0	118.0	13.2	35	150	1.0	200
ULCE64A	74.3	81.8	1.0	64	5.0	107.0	14.6	35	150	1.0	200
ULCE70	81.0	98.3	1.0	70	5.0	129.0	12.0	35	150	1.0	200
ULCE70A	81.0	89.2	1.0	70	5.0	117.0	13.3	35	150	1.0	200
ULCE75	86.5	105.2	1.0	75	5.0	138.0	11.2	35	150	1.0	200
ULCE75A	86.5	95.3	1.0	75	5.0	125.0	12.4	35	150	1.0	200
ULCE80	91.9	111.2	1.0	80	5.0	146.0	10.6	35	150	1.0	200
ULCE80A	91.9	101.2	1.0	80	5.0	133.0	11.6	35	150	1.0	200
ULCE90	103.2	125.2	1.0	90	5.0	164.0	9.4	35	300	1.0	200
ULCE90A	103.2	114.2	1.0	90	5.0	150.0	10.3	35	300	1.0	200



Automotive Transient Suppressor Diodes

The plastic material carries U/L recognition 94V-0.

Type No.	Breakdown Voltage @ I_R (Note 1) at $T_c = 25\text{ }^\circ\text{C}$		Working Peak Reverse Voltage	Maximum Average Forward Rectified Current	Maximum Reverse Current	Maximum Reverse Leakage @ V_{RWM}	Typical Temperature Coefficient of V_{BR} (% / $^\circ\text{C}$)
	V_{BR} (V)						
	Min.	Max.	(mA)	(V)	(A)	($^\circ\text{C}$)	(A)

MR2535 Series, Case Type: MR



MR2535	24	32	100	20	35	150	110	200	0.096
MR2540	24	32	100	20	50	150	150	200	0.096
MR3230	38	42	100	30	32	150	77.0	1000	-

MR2535L Series, Case Type: D6



MR2535L	24	32	100	20	35	150	110	200	0.096
MR2540L	24	32	100	20	50	150	150	200	0.096
PZ628	22	32	1.0	20	5.0	150	65	0.5mA	0.020

Note :

(1) Pulse set : Pulse Width $\leq 300\mu\text{s}$, Duty Cycle $\leq 2\%$



Automotive Transient Suppressor Diodes

The plastic material carries U/L recognition 94V-O.

Type No.	Breakdown Voltage @ I_t (Note 1)		Working Peak Reverse Voltage	Maximum Reverse Leakage @ V_{RWM}	Maximum Reverse Leakage @ V_{RWM} , $T_j=150^\circ\text{C}$	Maximum Peak Pulse Surge Current	Maximum Clamping Voltage @ I_{PPM}
	V_{BR} (V)						
	Min.	Max.	(mA)	(V)	(μA)	(μA)	(A)

TPSMC6.8 Series, 1500 W, Case Type: SMC



TPSMC6.8	6.12	7.48	10	5.50	1000	10000	139	10.8
TPSMC6.8A	6.45	7.14	10	5.80	1000	10000	143	10.5
TPSMC7.5	6.75	8.25	10	6.05	500	5000	128	11.7
TPSMC7.5A	7.13	7.88	10	6.40	500	2000	132	11.3
TPSMC8.2	7.38	9.02	10	6.63	200	2000	120	12.5
TPSMC8.2A	7.79	8.61	10	7.02	200	500	124	12.1
TPSMC9.1	8.19	10.0	1.0	7.37	50	500	109	13.8
TPSMC9.1A	8.65	9.55	1.0	7.78	50	200	112	13.4
TPSMC10	9.00	11.0	1.0	8.10	20	200	100	15.0
TPSMC10A	9.50	10.5	1.0	8.55	20	50	103	14.5
TPSMC11	9.90	12.1	1.0	8.92	5.0	50	92.6	16.2
TPSMC11A	10.5	11.6	1.0	9.40	5.0	10	96.2	15.6
TPSMC12	10.8	13.2	1.0	9.72	2.0	10	86.7	17.3
TPSMC12A	11.4	12.6	1.0	10.2	2.0	10	89.8	16.7
TPSMC13	11.7	14.3	1.0	10.5	2.0	10	78.9	19.0
TPSMC13A	12.4	13.7	1.0	11.1	2.0	10	82.4	18.2
TPSMC15	13.5	16.5	1.0	12.1	1.0	10	68.2	22.0
TPSMC15A	14.3	15.8	1.0	12.8	1.0	10	70.8	21.2
TPSMC16	14.4	17.6	1.0	12.9	1.0	10	63.8	23.5
TPSMC16A	15.2	16.8	1.0	13.6	1.0	10	66.7	22.5
TPSMC18	16.2	19.8	1.0	14.5	1.0	10	56.6	26.5
TPSMC18A	17.1	18.9	1.0	15.3	1.0	10	59.5	25.2
TPSMC20	18.0	22.0	1.0	16.2	1.0	10	51.5	29.1
TPSMC20A	19.0	21.0	1.0	17.1	1.0	10	54.2	27.7
TPSMC22	19.8	24.2	1.0	17.8	1.0	10	47.0	31.9
TPSMC22A	20.9	23.1	1.0	18.8	1.0	10	49.0	30.6
TPSMC24	21.6	26.4	1.0	19.4	1.0	10	43.2	34.7
TPSMC24A	22.8	25.2	1.0	20.5	1.0	10	45.2	33.2
TPSMC27	24.3	29.7	1.0	21.8	1.0	10	38.4	39.1
TPSMC27A	25.7	28.4	1.0	23.1	1.0	10	40.0	37.5
TPSMC30	27.0	33.0	1.0	24.3	1.0	10	34.5	43.5
TPSMC30A	28.5	31.5	1.0	25.6	1.0	10	36.2	41.4
TPSMC33	29.7	36.3	1.0	26.8	1.0	10	31.4	47.7
TPSMC33A	31.4	34.7	1.0	28.2	1.0	10	32.8	45.7
TPSMC36	32.4	39.6	1.0	29.1	1.0	10	28.8	52.0
TPSMC36A	34.2	37.8	1.0	30.8	1.0	10	30.1	49.9
TPSMC39	35.1	42.9	1.0	31.6	1.0	10	26.6	56.4
TPSMC39A	37.1	41.0	1.0	33.3	1.0	10	27.8	53.9
TPSMC43	38.7	47.3	1.0	34.8	1.0	10	24.2	61.9
TPSMC43A	40.9	45.2	1.0	36.8	1.0	10	25.3	59.3

Notes :

- (1) V_{BR} measured after I_t applied for 300 μs ., I_t = square wave pulse or equivalent
- (2) "PSMC" will be omitted on marking of the diode



Transient Voltage Suppressor Diodes for ESD Protection

Type No.	Working Peak Reverse Voltage	Breakdown Voltage @ I_T	Test Current	Max. Reverse Leakage Current	Max. Clamping Voltage at I_{PP}	Max. Reverse Peak Pulse Current	Max. Peak Power Dissipation	Typical Capacitance
	V_{RWM}	V_{BR} @ I_T	I_T	I_R @ V_{RWM}	V_C	I_{PP}	P_{PK}	C
	(V)	Min	(mA)	(μ A)	(V)	(mA)	(W)	(pF)

ESD5B5.0, 50W, Case Type: SOD-523



ESD5B5.0	5.0	5.8	1.0	1.0	-	-	50	32
----------	-----	-----	-----	-----	---	---	----	----

NZQA6V8, 100W, Case Type: SOT-553



NZQA6V8	4.3	6.4	1.0	1.0	12.5	8.0	100	70
---------	-----	-----	-----	-----	------	-----	-----	----

ESD9X5V, 150W, Case Type: SOD-923



ESD9X5V	5.0	6.2	1.0	1.0	12.3	8.7	150	65
---------	-----	-----	-----	-----	------	-----	-----	----

ESD9B5V, 150W, Case Type: SOD-923



ESD9B5V	5.0	5.8	1.0	1.0	-	-	150	15
---------	-----	-----	-----	-----	---	---	-----	----

MSQA6V1W5, 200W, Case Type: SOT-353



MSQA6V1W5	3.0	6.1	1.0	1.0	-	-	200	90
-----------	-----	-----	-----	-----	---	---	-----	----

ESD5Z Series, 240W, Case Type: SOD-523



ESD5Z3.3	3.3	1.0	8.4	5.0	11.2	158	105	105
ESD5Z5.0	5.0	1.0	11.6	6.2	9.4	174	80	80
ESD5Z6.0	6.0	1.0	12.4	6.8	8.8	181	70	70
ESD5Z7.0	7.0	1.0	13.5	7.5	8.8	200	65	65

SD05 & SD12, 350W, Case Type: SOD-323



SD05	5.0	6.2	1.0	10	14.5	24	350	350
SD12	12.0	13.3	1.0	1.0	25.0	15	350	150

SLVU2.8, 400W, Case Type: SOT-23



SLVU2.8	2.8	2.8	2(μ A)	1.0	3.9	2.0	400	3.5
---------	-----	-----	-------------	-----	-----	-----	-----	-----

SLVU2.8-4, 400W, Case Type: SOP-8



SLVU2.8-4	2.8	2.8	2(μ A)	1.0	5.5	2.0	400	3.5
-----------	-----	-----	-------------	-----	-----	-----	-----	-----



Transient Voltage Suppressor Array

Type No.	Working Peak Reverse Voltage	Breakdown Voltage @ I_T	Test Current	Max. Reverse Leakage Current	Max. Clamping Voltage at I_{PP}	Max. Reverse Peak Pulse Current	Max. Peak Power Dissipation	Typical Capacitance
	V_{RWM}	$V_{BR} @ I_T$	I_T	$I_R @ V_{RWM}$	V_C	I_{PP}	P_{PK}	C
	(V)	Min	(mA)	(μ A)	(V)	(mA)	(W)	(pF)

MSMF05C, 100W, Case Type: SOT-563

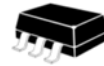

MSMF05C	5.0	6.0	1.0	1.0	9.8	1.0	100	40
---------	-----	-----	-----	-----	-----	-----	-----	----

ESDAxxL, 300W, Case Type: SOT-23



ESDA5V3L	3.00	5.3	1.0	2.0	-	-	300	220
ESDA6V1L	5.25	6.1	1	20	-	-	300	140

SRDA3.3-4, 500W, Case Type: SOP-8



SRDA3.3-4	3.3	3.5	2(μ A)	2.0	5.3	1.0	500	3.5
-----------	-----	-----	-------------	-----	-----	-----	-----	-----



Glass Passivated Bridge Rectifiers

The plastic material carries U/L recognition 94V-O.

Type No.	Max. Average Forward Rectified Current		Input Voltage Recommended	Max. Repetitive Peak Reverse Voltage VRRM	Max. Peak Forward Surge Current IFSM	Max. Forward Voltage Drop at Ta = 25°C		Max. Reverse Current at Ta = 25°C IR
	IF(AV) (A)	@ Tc (°C)				VF (V)	@ IF (A)	

W005G Series, 1.5 A, Case Type: WOB

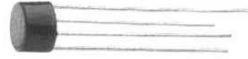

W005G	1.5	25	-	50	50	1.0	1.0	5
W01G	1.5	25	-	100	50	1.0	1.0	5
W02G	1.5	25	-	200	50	1.0	1.0	5
W04G	1.5	25	-	400	50	1.0	1.0	5
W06G	1.5	25	-	600	50	1.0	1.0	5
W08G	1.5	25	-	800	50	1.0	1.0	5
W10G	1.5	25	-	1000	50	1.0	1.0	5

KBL400G Series, 4 A, Case Type: KBL



KBL400G	4.0	50 (Ta)	-	50	150	1.1	4.0	10
KBL401G	4.0	50 (Ta)	-	100	150	1.1	4.0	10
KBL402G	4.0	50 (Ta)	-	200	150	1.1	4.0	10
KBL404G	4.0	50 (Ta)	-	400	150	1.1	4.0	10
KBL406G	4.0	50 (Ta)	-	600	150	1.1	4.0	10
KBL408G	4.0	50 (Ta)	-	800	150	1.1	4.0	10
KBL410G	4.0	50 (Ta)	-	1000	150	1.1	4.0	10

GBPC6005 Series, 6 A, Case Type: BR6

GBPC6005	6.0	50	-	50	175	1.0	3.0	5.0
GBPC601	6.0	50	-	100	175	1.0	3.0	5.0
GBPC602	6.0	50	-	200	175	1.0	3.0	5.0
GBPC604	6.0	50	-	400	175	1.0	3.0	5.0
GBPC606	6.0	50	-	600	175	1.0	3.0	5.0
GBPC608	6.0	50	-	800	175	1.0	3.0	5.0
GBPC2510	6.0	50	-	1000	175	1.0	3.0	5.0

GBPC25005 Series, 25 A, Case Type: BR50

GBPC25005	25	50	-	50	300	1.1	12.5	5.0
GBPC2501	25	50	-	100	300	1.1	12.5	5.0
GBPC2502	25	50	-	200	300	1.1	12.5	5.0
GBPC2504	25	50	-	400	300	1.1	12.5	5.0
GBPC2506	25	50	-	600	300	1.1	12.5	5.0
GBPC2508	25	50	-	800	300	1.1	12.5	5.0
GBPC2510	25	50	-	1000	300	1.1	12.5	5.0



BR6



BR50



Silicon Bridge Rectifiers

The plastic material carries U/L recognition 94V-0.

Type No.	Max. Average Forward Rectified Current		Input Voltage Recommended	Max. Repetitive Peak Reverse Voltage VRRM	Max. Peak Forward Surge Current IFSM	Max. Forward Voltage Drop at Ta = 25°C		Max. Reverse Current at Ta = 25°C IR
	IF(AV) (A)	@ Tc (°C)				VF (V)	@ IF (A)	

B40-C1000 Series, 1 A, Case Type: WOB



B40-C1000	1.0	45	40	100	40	1.0	1.0	10
B80-C1000	1.0	45	80	200	40	1.0	1.0	10
B125-C1000	1.0	45	125	300	40	1.0	1.0	10
B250-C1000	1.0	45	250	600	40	1.0	1.0	10
B380-C1000	1.0	45	380	900	40	1.0	1.0	10

B40-C1500R Series, 1.5 A, Case Type: WOB



B40-C1500R	1.5	45	40	100	50	1.0	1.5	10
B80-C1500R	1.5	45	80	200	50	1.0	1.5	10
B125-C1500R	1.5	45	125	300	50	1.0	1.5	10
B250-C1500R	1.5	45	250	600	50	1.0	1.5	10
B380-C1500R	1.5	45	380	900	50	1.0	1.5	10

WL005 Series, 1 A, Case Type: WOB



WL005	1.0	50	20	50	30	1.2	1.0	10
WL01	1.0	50	40	100	30	1.2	1.0	10
WL02	1.0	50	80	200	30	1.2	1.0	10
WL04	1.0	50	125	400	30	1.2	1.0	10
WL06	1.0	50	250	600	30	1.2	1.0	10
WL08	1.0	50	380	800	30	1.2	1.0	10
WL10	1.0	50	440	1000	30	1.2	1.0	10

W005 Series, 1.5 A, Case Type: WOB



W005	1.5	25	20	50	50	1.0	1.0	10
W01	1.5	25	40	100	50	1.0	1.0	10
W02	1.5	25	80	200	50	1.0	1.0	10
W04	1.5	25	125	400	50	1.0	1.0	10
W06	1.5	25	250	600	50	1.0	1.0	10
W08	1.5	25	380	800	50	1.0	1.0	10
W10	1.5	25	440	1000	50	1.0	1.0	10

1B4B1 Series, 1.5 A, Case Type: WOB



1B4B1	1.5	50 (Ta)	100	-	50	1.2	1.5	400
1G4B1	1.5	50 (Ta)	200	-	50	1.2	1.5	400
1J4B1	1.5	50 (Ta)	600	-	50	1.2	1.5	400

2W Series, 2 A, Case Type: WOB



2W005	2.0	25	20	50	50	1.0	1.0	10
2W01	2.0	25	40	100	50	1.0	1.0	10
2W02	2.0	25	80	200	50	1.0	1.0	10
2W04	2.0	25	125	400	50	1.0	1.0	10
2W06	2.0	25	250	600	50	1.0	1.0	10
2W08	2.0	25	380	800	50	1.0	1.0	10
2W10	2.0	25	440	1000	50	1.0	1.0	10



Silicon Bridge Rectifiers

The plastic material carries U/L recognition 94V-0.

Type No.	Max. Average Forward Rectified Current		Input Voltage Recommended	Max. Repetitive Peak Reverse Voltage VRRM	Max. Peak Forward Surge Current IFSM	Max. Forward Voltage Drop at Ta = 25°C		Max. Reverse Current at Ta = 25°C IR
	IF(AV)	@ Tc				VF	@ IF	
	(A)	(°C)	(V)	(V)	(A)	(V)	(A)	(μA)

RB150 Series, 1.5 A, Case Type: RB



RB150	1.5	50	20	50	40	0.95	1.0	10
RB151	1.5	50	40	100	40	0.95	1.0	10
RB152	1.5	50	80	200	40	0.95	1.0	10
RB154	1.5	50	125	400	40	0.95	1.0	10
RB156	1.5	50	250	600	40	0.95	1.0	10
RB158	1.5	50	380	800	40	0.95	1.0	10

2KBP005 Series, 2 A, Case Type: KBP



2KBP005	2.0	55	-	50	60	1.0	3.14	10
2KBP01	2.0	55	-	100	60	1.0	3.14	10
2KBP02	2.0	55	-	200	60	1.0	3.14	10
2KBP04	2.0	55	-	400	60	1.0	3.14	10
2KBP06	2.0	55	-	600	60	1.0	3.14	10
2KBP08	2.0	55	-	800	60	1.0	3.14	10
2KBP10	2.0	55	-	1000	60	1.0	3.14	10

KBP200 Series, 2 A, Case Type: KBP



KBP200	2.0	50	20	50	60	1.0	1.0	10
KBP201	2.0	50	40	100	60	1.0	1.0	10
KBP202	2.0	50	80	200	60	1.0	1.0	10
KBP204	2.0	50	125	400	60	1.0	1.0	10
KBP206	2.0	50	250	600	60	1.0	1.0	10
KBP208	2.0	50	380	800	60	1.0	1.0	10
KBP210	2.0	50	440	1000	60	1.0	1.0	10

KBL400 Series, 4 A, Case Type: KBL



KBL400	4.0	50	20	50	200	1.1	4.0	10
KBL401	4.0	50	40	100	200	1.1	4.0	10
KBL402	4.0	50	80	200	200	1.1	4.0	10
KBL404	4.0	50	125	400	200	1.1	4.0	10
KBL406	4.0	50	250	600	200	1.1	4.0	10
KBL408	4.0	50	380	800	200	1.1	4.0	10
KBL410	4.0	50	440	1000	200	1.1	4.0	10



Silicon Bridge Rectifiers

The plastic material carries U/L recognition 94V-0.

Type No.	Max. Average Forward Rectified Current		Input Voltage Recommended	Max. Repetitive Peak Reverse Voltage VRRM	Max. Peak Forward Surge Current IFSM	Max. Forward Voltage Drop at Ta = 25°C		Max. Reverse Current at Ta = 25°C IR
	IF(AV) (A)	@ Tc (°C)				VF (V)	@ IF (A)	

KBU4A Series, 4 A, Case Type: KBU



KBU4A	4.0	30	-	50	200	1.0	4.0	5.0
KBU4B	4.0	30	-	100	200	1.0	4.0	5.0
KBU4D	4.0	30	-	200	200	1.0	4.0	5.0
KBU4G	4.0	30	-	400	200	1.0	4.0	5.0
KBU4J	4.0	30	-	600	200	1.0	4.0	5.0
KBU4K	4.0	30	-	800	200	1.0	4.0	5.0
KBU4M	4.0	30	-	1000	200	1.0	4.0	5.0

GBU4A Series, 4 A, Case Type: GBU

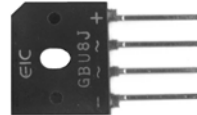

GBU4A	4.0	100	-	50	80	1.0	4.0	5.0
GBU4B	4.0	100	-	100	80	1.0	4.0	5.0
GBU4D	4.0	100	-	200	80	1.0	4.0	5.0
GBU4G	4.0	100	-	400	80	1.0	4.0	5.0
GBU4J	4.0	100	-	600	80	1.0	4.0	5.0
GBU4K	4.0	100	-	800	80	1.0	4.0	5.0
GBU4M	4.0	100	-	1000	80	1.0	4.0	5.0

KBU6A Series, 6 A, Case Type: KBU



KBU6A	6.0	100	-	50	250	1.0	6.0	5.0
KBU6B	6.0	100	-	100	250	1.0	6.0	5.0
KBU6D	6.0	100	-	200	250	1.0	6.0	5.0
KBU6G	6.0	100	-	400	250	1.0	6.0	5.0
KBU6J	6.0	100	-	600	250	1.0	6.0	5.0
KBU6K	6.0	100	-	800	250	1.0	6.0	5.0
KBU6M	6.0	100	-	1000	250	1.0	6.0	5.0

KBU8A Series, 8 A, Case Type: KBU



KBU8A	8.0	65	-	50	250	1.0	8.0	10
KBU8B	8.0	65	-	100	250	1.0	8.0	10
KBU8D	8.0	65	-	200	250	1.0	8.0	10
KBU8G	8.0	65	-	400	250	1.0	8.0	10
KBU8J	8.0	65	-	600	250	1.0	8.0	10
KBU8K	8.0	65	-	800	250	1.0	8.0	10
KBU8M	8.0	65	-	1000	250	1.0	8.0	10



Silicon Bridge Rectifiers

The plastic material carries U/L recognition 94V-0.

Type No.	Max. Average Forward Rectified Current		Input Voltage Recommended	Max. Repetitive Peak Reverse Voltage	Max. Peak Forward Surge Current	Max. Forward Voltage Drop at Ta = 25°C		Max. Reverse Current at Ta = 25°C
	IF(AV)	@ Tc				VF	@ IF	
	(A)	(°C)	(V)	VRRM (V)	IFSM (A)	(V)	(A)	IR (μA)

GBU8A Series, 8 A, Case Type: GBU

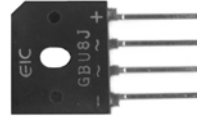

GBU8A	8.0	100	-	50	200	1.0	8.0	5.0
GBU8B	8.0	100	-	100	200	1.0	8.0	5.0
GBU8D	8.0	100	-	200	200	1.0	8.0	5.0
GBU8G	8.0	100	-	400	200	1.0	8.0	5.0
GBU8J	8.0	100	-	600	200	1.0	8.0	5.0
GBU8K	8.0	100	-	800	200	1.0	8.0	5.0
GBU8M	8.0	100	-	1000	200	1.0	8.0	5.0

GBU8005 Series, 8 A, Case Type: GBU

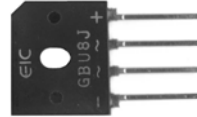

GBU8005	8.0	100	-	50	200	1.0	4.0	5.0
GBU801	8.0	100	-	100	200	1.0	4.0	5.0
GBU802	8.0	100	-	200	200	1.0	4.0	5.0
GBU804	8.0	100	-	400	200	1.0	4.0	5.0
GBU806	8.0	100	-	600	200	1.0	4.0	5.0
GBU808	8.0	100	-	800	200	1.0	4.0	5.0
GBU810	8.0	100	-	1000	200	1.0	4.0	5.0

Silicon Bridge Rectifiers

The plastic material carries U/L recognition 94V-0.

Type No.		Max. Average Forward Rectified Current		Input Voltage Recommended	Max. Repetitive Peak Reverse Voltage	Max. Peak Forward Surge Current	Max. Forward Voltage Drop at Ta = 25°C		Max. Reverse Current at Ta = 25°C
		IF(AV) @ Tc					VF @ IF		
DIP	SIP	(A)	(°C)	(V)	(V)	(A)	(V)	(A)	(µA)

RBV400 Series, 4 A, Case Type: RBV4

	RBV401	4.0	50	-	100	80	1.05	2.0	10
	RBV402	4.0	50	-	200	80	1.05	2.0	10
	RBV404	4.0	50	-	400	80	1.10	2.0	10
	RBV406	4.0	50	-	600	80	1.10	2.0	10
	RBV408	4.0	50	-	800	80	1.10	2.0	10
	RBV410	4.0	50	-	1000	80	1.10	2.0	10

D3SB10 Series, 4 A, Case Type: RBV4

	D3SB10	4.0	25	-	100	120	1.05	2.0	10
	D3SB20	4.0	25	-	200	120	1.05	2.0	10
	D3SB40	4.0	25	-	400	120	1.10	2.0	10
	D3SB60	4.0	25	-	600	120	1.10	2.0	10
	D3SB80	4.0	25	-	800	120	1.10	2.0	10
	D4SB80	4.0	108	-	800	150	0.95	2.0	10

D3SBA10 Series, 4 A, Case Type: RBV4

	D3SBA10	4.0	25	-	100	80	1.05	2.0	10
	D3SBA20	4.0	25	-	200	80	1.05	2.0	10
	D3SBA40	4.0	25	-	400	80	1.10	2.0	10
	D3SBA60	4.0	25	-	600	80	1.10	2.0	10
	D3SBA80	4.0	25	-	800	80	1.10	2.0	10

D5SBA10 Series, 6 A, Case Type: RBV25

	D5SBA10	6.0	25	-	100	120	1.05	3.0	10
	D5SBA20	6.0	25	-	200	120	1.05	3.0	10
	D5SBA40	6.0	25	-	400	120	1.10	3.0	10
	D5SBA60	6.0	25	-	600	120	1.10	3.0	10

BR600/RBV600 Series, 6 A, Case Type: BR6/RBV25

BR600	RBV600	6.0	50	20	50	200	1.0	3.0	10
BR601	RBV601	6.0	50	40	100	200	1.0	3.0	10
BR602	RBV602	6.0	50	80	200	200	1.0	3.0	10
BR604	RBV604	6.0	50	125	400	200	1.0	3.0	10
BR606	RBV606	6.0	50	250	600	200	1.0	3.0	10
BR608	RBV608	6.0	50	380	800	200	1.0	3.0	10
BR610	RBV610	6.0	50	440	1000	200	1.0	3.0	10



BR6

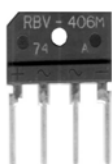

RBV4



RBV25



Silicon Bridge Rectifiers

The plastic material carries U/L recognition 94V-0.

Type No.		Max. Average Forward Rectified Current		Input Voltage Recommended	Max. Repetitive Peak Reverse Voltage	Max. Peak Forward Surge Current	Max. Forward Voltage Drop at Ta = 25°C		Max. Reverse Current at Ta = 25°C
		I _{F(AV)}	@ T _c				V _F	@ I _F	
DIP	SIP	(A)	(°C)	(V)	(V)	(A)	(V)	(A)	(μA)

RBV600D Series, 6 A, Case Type: RBV25

Type No.	Case Type	I _{F(AV)} (A)	T _c (°C)	V _{RRM} (V)	I _{FSM} (A)	V _F (V)	I _F (A)	I _R (μA)	
RBV600D	RBV25	6.0	50	20	50	300	1.0	6.0	10
RBV601D	RBV25	6.0	50	40	100	300	1.0	6.0	10
RBV602D	RBV25	6.0	50	80	200	300	1.0	6.0	10
RBV604D	RBV25	6.0	50	125	400	300	1.0	6.0	10
RBV606D	RBV25	6.0	50	250	600	300	1.0	6.0	10
RBV608D	RBV25	6.0	50	380	800	300	1.0	6.0	10
RBV610D	RBV25	6.0	50	440	1000	300	1.0	6.0	10

BR800/RBV800 Series, 8 A, Case Type: BR10/RBV25

Type No.	Case Type	I _{F(AV)} (A)	T _c (°C)	V _{RRM} (V)	I _{FSM} (A)	V _F (V)	I _F (A)	I _R (μA)	
BR800	RBV25	8.0	50	20	50	300	1.0	4.0	10
BR801	RBV25	8.0	50	40	100	300	1.0	4.0	10
BR802	RBV25	8.0	50	80	200	300	1.0	4.0	10
BR804	RBV25	8.0	50	125	400	300	1.0	4.0	10
BR806	RBV25	8.0	50	250	600	300	1.0	4.0	10
BR808	RBV25	8.0	50	380	800	300	1.0	4.0	10
BR810	RBV25	8.0	50	440	1000	300	1.0	4.0	10

RBV800D Series, 8 A, Case Type: RBV25

Type No.	Case Type	I _{F(AV)} (A)	T _c (°C)	V _{RRM} (V)	I _{FSM} (A)	V _F (V)	I _F (A)	I _R (μA)	
RBV800D	RBV25	8.0	50	20	50	300	1.0	8.0	10
RBV801D	RBV25	8.0	50	40	100	300	1.0	8.0	10
RBV802D	RBV25	8.0	50	80	200	300	1.0	8.0	10
RBV804D	RBV25	8.0	50	125	400	300	1.0	8.0	10
RBV806D	RBV25	8.0	50	250	600	300	1.0	8.0	10
RBV808D	RBV25	8.0	50	380	800	300	1.0	8.0	10
RBV810D	RBV25	8.0	50	440	1000	300	1.0	8.0	10

BR1000/RBV1000 Series, 10 A, Case Type: BR10/RBV25

Type No.	Case Type	I _{F(AV)} (A)	T _c (°C)	V _{RRM} (V)	I _{FSM} (A)	V _F (V)	I _F (A)	I _R (μA)	
BR1000	RBV25	10	55	20	50	300	1.0	5.0	10
BR1001	RBV25	10	55	40	100	300	1.0	5.0	10
BR1002	RBV25	10	55	80	200	300	1.0	5.0	10
BR1004	RBV25	10	55	125	400	300	1.0	5.0	10
BR1006	RBV25	10	55	250	600	300	1.0	5.0	10
BR1008	RBV25	10	55	380	800	300	1.0	5.0	10
BR1010	RBV25	10	55	440	1000	300	1.0	5.0	10



BR10



RBV25



Silicon Bridge Rectifiers

The plastic material carries U/L recognition 94V-0.

Type No.		Max. Average Forward Rectified Current		Input Voltage Recommended	Max. Repetitive Peak Reverse Voltage	Max. Peak Forward Surge Current	Max. Forward Voltage Drop at Ta = 25°C		Max. Reverse Current at Ta = 25°C
		IF(AV) @	Tc				VF @	IF	
DIP	SIP	(A)	(°C)	(V)	VRRM	IFSM	(V)	(A)	(μA)

RBV1000D Series, 10 A, Case Type: RBV25

	RBV1000D	10	55	20	50	300	1.1	10	10
	RBV1001D	10	55	40	100	300	1.1	10	10
	RBV1002D	10	55	80	200	300	1.1	10	10
	RBV1004D	10	55	125	400	300	1.1	10	10
	RBV1006D	10	55	250	600	300	1.1	10	10
	RBV1008D	10	55	380	800	300	1.1	10	10
	RBV1010D	10	55	440	1000	300	1.1	10	10

KBPC1000 Series, 10 A, Case Type: BR50M

KBPC1000		10	55	-	50	200	1.2	5.0	10
KBPC1001		10	55	-	100	200	1.2	5.0	10
KBPC1002		10	55	-	200	200	1.2	5.0	10
KBPC1004		10	55	-	400	200	1.2	5.0	10
KBPC1006		10	55	-	600	200	1.2	5.0	10
KBPC1008		10	55	-	800	200	1.2	5.0	10
KBPC1010		10	55	-	1000	200	1.2	5.0	10

BR1500/RBV1500 Series, 15 A, Case Type: BR50/RBV25

BR1500	RBV1500	15	55	20	50	300	1.1	7.5	10
BR1501	RBV1501	15	55	40	100	300	1.1	7.5	10
BR1502	RBV1502	15	55	80	200	300	1.1	7.5	10
BR1504	RBV1504	15	55	125	400	300	1.1	7.5	10
BR1506	RBV1506	15	55	250	600	300	1.1	7.5	10
BR1508	RBV1508	15	55	380	800	300	1.1	7.5	10
BR1510	RBV1510	15	55	440	1000	300	1.1	7.5	10

* For wire leads use suffix "W" for Case Type : BR50W

RBV1500D Series, 15 A, Case Type: RBV25

	RBV1500D	15	55	20	50	300	1.1	15	10
	RBV1501D	15	55	40	100	300	1.1	15	10
	RBV1502D	15	55	80	200	300	1.1	15	10
	RBV1504D	15	55	125	400	300	1.1	15	10
	RBV1506D	15	55	250	600	300	1.1	15	10
	RBV1508D	15	55	380	800	300	1.1	15	10
	RBV1510D	15	55	440	1000	300	1.1	15	10



RBV25



BR50



BR50M



BR50W

Silicon Bridge Rectifiers

The plastic material carries U/L recognition 94V-0.

Type No.		Max. Average Forward Rectified Current		Input Voltage Recommended	Max. Repetitive Peak Reverse Voltage	Max. Peak Forward Surge Current	Max. Forward Voltage Drop at Ta = 25°C		Max. Reverse Current at Ta = 25°C
		IF(AV) @	Tc				VF @	IF	
DIP	SIP	(A)	(°C)	(V)	VRRM	IFSM	(V)	(A)	(μA)

KBPC1500 Series, 15 A, Case Type: BR50M

KBPC1500		15	55	-	50	300	1.2	7.5	10
KBPC1501		15	55	-	100	300	1.2	7.5	10
KBPC1502		15	55	-	200	300	1.2	7.5	10
KBPC1504		15	55	-	400	300	1.2	7.5	10
KBPC1506		15	55	-	600	300	1.2	7.5	10
KBPC1508		15	55	-	800	300	1.2	7.5	10
KBPC1510		15	55	-	1000	300	1.2	7.5	10

S15VB20 Series, 15 A, Case Type: BR50

S15VB20		15	83	-	200	200	1.05	7.5	10
S15VB60		15	83	-	600	200	1.05	7.5	10

D20XB20 Series, 20 A, Case Type: RBV25

	D20XB20	20	87	-	200	240	1.1	10	10
	D20XB60	20	87	-	600	240	1.1	10	10

BR2500/RBV2500 Series, 25 A, Case Type: BR50/RBV25

BR2500	RBV2500	25	55	20	50	300	1.1	12.5	10
BR2501	RBV2501	25	55	40	100	300	1.1	12.5	10
BR2502	RBV2502	25	55	80	200	300	1.1	12.5	10
BR2504	RBV2504	25	55	125	400	300	1.1	12.5	10
BR2506	RBV2506	25	55	250	600	300	1.1	12.5	10
BR2508	RBV2508	25	55	380	800	300	1.1	12.5	10
BR2510	RBV2510	25	55	440	1000	300	1.1	12.5	10

* For wire leads use suffix "W" for Case Type : BR50W

D25XB20 Series, 25 A, Case Type: RBV25

	D25XB20	25	98	-	200	350	1.05	12.5	10
	D25XB60	25	98	-	600	350	1.05	12.5	10



RBV25



BR50



BR50M



BR50W



Silicon Bridge Rectifiers

The plastic material carries U/L recognition 94V-0.

Type No.		Max. Average Forward Rectified Current		Input Voltage Recommended	Max. Repetitive Peak Reverse Voltage	Max. Peak Forward Surge Current	Max. Forward Voltage Drop at Ta = 25°C		Max. Reverse Current at Ta = 25°C
		IF(AV) @ Tc					VF @ IF		
DIP	SIP	(A)	(°C)	(V)	(V)	(A)	(V)	(A)	(μA)

GBJ2500 Series, 25 A, Case Type: RBV25

	GBJ2500	25	100	-	50	300	1.1	12.5	10
	GBJ2501	25	100	-	100	300	1.1	12.5	10
	GBJ2502	25	100	-	200	300	1.1	12.5	10
	GBJ2504	25	100	-	400	300	1.1	12.5	10
	GBJ2506	25	100	-	600	300	1.1	12.5	10
	GBJ2508	25	100	-	800	300	1.1	12.5	10
	GBJ2510	25	100	-	1000	300	1.1	12.5	10

S25VB20 Series, 25 A, Case Type: BR50

S25VB20		25	85	-	200	400	1.05	12.5	10
S25VB60		25	85	-	600	400	1.05	12.5	10

RBV2500 Series, 25 A, Case Type: RBV25

	RBV2500D	25	55	20	50	400	1.1	25	10
	RBV2501D	25	55	40	100	400	1.1	25	10
	RBV2502D	25	55	80	200	400	1.1	25	10
	RBV2504D	25	55	125	400	400	1.1	25	10
	RBV2506D	25	55	250	600	400	1.1	25	10
	RBV2508D	25	55	380	800	400	1.1	25	10
	RBV2510D	25	55	440	1000	400	1.1	25	10

KBPC2500 Series, 25 A, Case Type: BR50M

KBPC2500		25	55	-	50	300	1.1	12.5	10
KBPC2501		25	55	-	100	300	1.1	12.5	10
KBPC2502		25	55	-	200	300	1.1	12.5	10
KBPC2504		25	55	-	400	300	1.1	12.5	10
KBPC2506		25	55	-	600	300	1.1	12.5	10
KBPC2508		25	55	-	800	300	1.1	12.5	10
KBPC2510		25	55	-	1000	300	1.1	12.5	10



RBV25



BR50



BR50M



BR50W

Silicon Bridge Rectifiers

The plastic material carries U/L recognition 94V-0.

Type No.		Max. Average Forward Rectified Current		Input Voltage Recommended	Max. Repetitive Peak Reverse Voltage	Max. Peak Forward Surge Current	Max. Forward Voltage Drop at Ta = 25°C		Max. Reverse Current at Ta = 25°C
		I _{F(AV)}	@ T _c				V _F	@ I _F	
DIP	SIP	(A)	(°C)	(V)	(V)	(A)	(V)	(A)	(μA)

KBPC3500 Series, 35 A, Case Type: BR50M

KBPC3500		35	55	-	50	400	1.1	17.5	10
KBPC3501		35	55	-	100	400	1.1	17.5	10
KBPC3502		35	55	-	200	400	1.1	17.5	10
KBPC3504		35	55	-	400	400	1.1	17.5	10
KBPC3506		35	55	-	600	400	1.1	17.5	10
KBPC3508		35	55	-	800	400	1.1	17.5	10
KBPC3510		35	55	-	1000	400	1.1	17.5	10

BR3500/RBV3500 Series, 35 A, Case Type: BR50/RBV25

BR3500	RBV3500	35	55	20	50	400	1.1	17.5	10
BR3501	RBV3501	35	55	40	100	400	1.1	17.5	10
BR3502	RBV3502	35	55	80	200	400	1.1	17.5	10
BR3504	RBV3504	35	55	125	400	400	1.1	17.5	10
BR3506	RBV3506	35	55	250	600	400	1.1	17.5	10
BR3508	RBV3508	35	55	380	800	400	1.1	17.5	10
BR3510	RBV3510	35	55	440	1000	400	1.1	17.5	10

* For wire leads use suffix "W" for Case Type : BR50W

BR5000/RBV5000 Series, 50 A, Case Type: BR50/RBV25

BR5000	RBV5000	50	55	20	50	400	1.1	25	10
BR5001	RBV5001	50	55	40	100	400	1.1	25	10
BR5002	RBV5002	50	55	80	200	400	1.1	25	10
BR5004	RBV5004	50	55	125	400	400	1.1	25	10
BR5006	RBV5006	50	55	250	600	400	1.1	25	10
BR5008	RBV5008	50	55	380	800	400	1.1	25	10
BR5010	RBV5010	50	55	440	1000	400	1.1	25	10

* For wire leads use suffix "W" for Case Type : BR50W

KBPC5000 Series, 50 A, Case Type: BR50M

KBPC5000		50	55	-	50	400	1.1	25	10
KBPC5001		50	55	-	100	400	1.1	25	10
KBPC5002		50	55	-	200	400	1.1	25	10
KBPC5004		50	55	-	400	400	1.1	25	10
KBPC5006		50	55	-	600	400	1.1	25	10
KBPC5008		50	55	-	800	400	1.1	25	10
KBPC5010		50	55	-	1000	400	1.1	25	10



RBV25



BR50



BR50M



BR50W



Mini Bridge Rectifiers

The plastic material carries U/L recognition 94V-0.

Type No.	Max. Average Forward Rectified Current		Input Voltage Recommended	Max. Repetitive Peak Reverse Voltage	Max. Peak Forward Surge Current	Max. Forward Voltage Drop at Ta = 25°C		Max. Reverse Current at Ta = 25°C
	IF(AV)	@ Tc				VF	@ IF	
	(A)	(°C)	(V)	(V)	(A)	(V)	(A)	(μA)

MB1S Series, 0.5 A, Case Type: MBS



MB1S	0.5	30	-	100	35	1.0	0.4	5.0
MB2S	0.5	30	-	200	35	1.0	0.4	5.0
MB4S	0.5	30	-	400	35	1.0	0.4	5.0
MB6S	0.5	30	-	600	35	1.0	0.4	5.0
MB8S	0.5	30	-	800	35	1.0	0.4	5.0
MB10S	0.5	30	-	1000	35	1.0	0.4	5.0

MB1M Series, 0.5 A, Case Type: MBM



MB1M	0.5	30	-	100	35	1.0	0.4	5.0
MB2M	0.5	30	-	200	35	1.0	0.4	5.0
MB4M	0.5	30	-	400	35	1.0	0.4	5.0
MB6M	0.5	30	-	600	35	1.0	0.4	5.0
MB8M	0.5	30	-	800	35	1.0	0.4	5.0
MB10M	0.5	30	-	1000	35	1.0	0.4	5.0

S1ZB20 Series, 0.8 A, Case Type: MBS



S1ZB20	0.8	30	-	200	30	1.05	0.4	10
S1ZB60	0.8	30	-	600	30	1.05	0.4	10
S1ZB80	0.8	30	-	800	30	1.05	0.4	10

DB101 Series, 1 A, Case Type: DFM



DB101	1.0	40	-	50	40	1.1	1.0	5.0
DB102	1.0	40	-	100	40	1.1	1.0	5.0
DB103	1.0	40	-	200	40	1.1	1.0	5.0
DB104	1.0	40	-	400	40	1.1	1.0	5.0
DB105	1.0	40	-	600	40	1.1	1.0	5.0
DB106	1.0	40	-	800	40	1.1	1.0	5.0
DB107	1.0	40	-	1000	40	1.1	1.0	5.0

DF005S Series, 1 A, Case Type: DFS



DF005S	1.0	40	-	50	30	1.1	1.0	10
DF01S	1.0	40	-	100	30	1.1	1.0	10
DF02S	1.0	40	-	200	30	1.1	1.0	10
DF04S	1.0	40	-	400	30	1.1	1.0	10
DF06S	1.0	40	-	600	30	1.1	1.0	10
DF08S	1.0	40	-	800	30	1.1	1.0	10
DF10S	1.0	40	-	1000	30	1.1	1.0	10



Mini Bridge Rectifiers

The plastic material carries U/L recognition 94V-0.

Type No.	Max. Average Forward Rectified Current		Input Voltage Recommended	Max. Repetitive Peak Reverse Voltage	Max. Peak Forward Surge Current	Max. Forward Voltage Drop at Ta = 25°C		Max. Reverse Current at Ta = 25°C
	IF(AV)	@ Tc				VF	@ IF	
	(A)	(°C)	(V)	(V)	(A)	(V)	(A)	(μA)

DF005M Series, 1 A, Case Type: DFM



DF005M	1.0	40	-	50	30	1.1	1.0	5.0
DF01M	1.0	40	-	100	30	1.1	1.0	5.0
DF02M	1.0	40	-	200	30	1.1	1.0	5.0
DF04M	1.0	40	-	400	30	1.1	1.0	5.0
DF06M	1.0	40	-	600	30	1.1	1.0	5.0
DF08M	1.0	40	-	800	30	1.1	1.0	5.0
DF10M	1.0	40	-	1000	30	1.1	1.0	5.0

DF15005S Series, 1.5 A, Case Type: DFS



DF15005S	1.5	40	-	50	50	1.1	1.5	10
DF1501S	1.5	40	-	100	50	1.1	1.5	10
DF1502S	1.5	40	-	200	50	1.1	1.5	10
DF1504S	1.5	40	-	400	50	1.1	1.5	10
DF1506S	1.5	40	-	600	50	1.1	1.5	10
DF1508S	1.5	40	-	800	50	1.1	1.5	10
DF1510S	1.5	40	-	1000	50	1.1	1.5	10

DF15005M Series, 1.5 A, Case Type: DFM



DF15005M	1.5	40 (Ta)	-	50	50	1.1	1.5	5.0
DF1501M	1.5	40 (Ta)	-	100	50	1.1	1.5	5.0
DF1502M	1.5	40 (Ta)	-	200	50	1.1	1.5	5.0
DF1504M	1.5	40 (Ta)	-	400	50	1.1	1.5	5.0
DF1506M	1.5	40 (Ta)	-	600	50	1.1	1.5	5.0
DF1508M	1.5	40 (Ta)	-	800	50	1.1	1.5	5.0
DF1510M	1.5	40 (Ta)	-	1000	50	1.1	1.5	5.0



Ultra Fast Recovery Mini Bridge Rectifiers

The plastic material carries U/L recognition 94V-0.

Type No.	Max. Average Forward Rectified Current		Input Voltage Recommended	Max. Repetitive Peak Reverse Voltage	Max. Peak Forward Surge Current	Max. Forward Voltage Drop at Ta = 25°C		Max. Reverse Current at Ta = 25°C	Max. Reverse Recovery Time ⁽¹⁾
	I _{F(AV)} (A)	@ T _C (°C)				V _F	@ I _F (A)		

EDF1AS Series, 1 A, Case Type: DFS



EDF1AS	1.0	40	-	50	50	1.05	1.0	5.0	50
EDF1BS	1.0	40	-	100	50	1.05	1.0	5.0	50
EDF1CS	1.0	40	-	150	50	1.05	1.0	5.0	50
EDF1DS	1.0	40	-	200	50	1.05	1.0	5.0	50

EDF1AM Series, 1 A, Case Type: DFM



EDF1AM	1.0	40	-	50	50	1.05	1.0	5.0	50
EDF1BM	1.0	40	-	100	50	1.05	1.0	5.0	50
EDF1CM	1.0	40	-	150	50	1.05	1.0	5.0	50
EDF1DM	1.0	40	-	200	50	1.05	1.0	5.0	50

Fast Recovery Mini Bridge Rectifiers

RMB2S Series, 0.5 A, Case Type: MBS



RMB2S	0.5	30	-	200	30	1.25	0.4	5.0	150
RMB4S	0.5	30	-	400	30	1.25	0.4	5.0	150

Note :

(1) Reverse Recovery test conditions : I_F = 0.5 A, I_R = 1 A, I_{rr} = 0.25 A



Avalanche Glass Passivated Bridge Rectifiers

The plastic material carries U/L recognition 94V-0.

Type No.	Max. Average Forward Rectified Current		Input Voltage Recommended	Max. Repetitive Peak Reverse Voltage	Avalanche Breakdown Voltage at 100 mA		Max. Forward Peak Surge Current	Max. Forward Voltage Drop at Ta = 25°C		Max. Reverse Current at Ta = 25°C
	IF(AV) @ (A)	Tc (°C)			VRRM (V)	Min. (V)		Max. (V)	IFSM (A)	

AB40-C1000G Series, 1 A, Case Type: WOB



AB40-C1000G	1.0	45	40	100	150	600	40	1.0	1.0	10
AB80-C1000G	1.0	45	80	200	250	700	40	1.0	1.0	10
AB125-C1000G	1.0	45	125	300	350	800	40	1.0	1.0	10
AB250-C1000G	1.0	45	250	600	700	1150	40	1.0	1.0	10
AB380-C1000G	1.0	45	380	900	1000	1450	40	1.0	1.0	10

AB40-C1500RG Series, 1.5A, Case Type:WOB

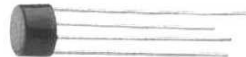

AB40-C1500RG	1.5	45	40	100	150	600	50	1.0	1.5	10
AB80-C1500RG	1.5	45	80	200	250	700	50	1.0	1.5	10
AB125-C1500RG	1.5	45	125	300	350	800	50	1.0	1.5	10
AB250-C1500RG	1.5	45	250	600	700	1150	50	1.0	1.5	10
AB380-C1500RG	1.5	45	380	900	1000	1450	50	1.0	1.5	10

AWL005G Series, 1 A, Case Type: WOB

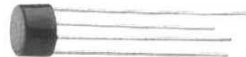

AWL005G	1.0	50	20	50	100	550	30	1.2	1.0	10
AWL01G	1.0	50	40	100	150	600	30	1.2	1.0	10
AWL02G	1.0	50	80	200	250	700	30	1.2	1.0	10
AWL04G	1.0	50	125	400	450	900	30	1.2	1.0	10
AWL06G	1.0	50	250	600	700	1150	30	1.2	1.0	10
AWL08G	1.0	50	380	800	900	1350	30	1.2	1.0	10
AWL10G	1.0	50	440	1000	1100	1550	30	1.2	1.0	10

AW005G Series, 1.5 A, Case Type: WOB



AW005G	1.5	25	20	50	100	550	50	1.0	1.0	10
AW01G	1.5	25	40	100	150	600	50	1.0	1.0	10
AW02G	1.5	25	80	200	250	700	50	1.0	1.0	10
AW04G	1.5	25	125	400	450	900	50	1.0	1.0	10
AW06G	1.5	25	250	600	700	1150	50	1.0	1.0	10
AW08G	1.5	25	380	800	900	1350	50	1.0	1.0	10
AW10G	1.5	25	440	1000	1100	1550	50	1.0	1.0	10

A2W005G Series, 2 A, Case Type: WOB

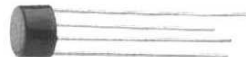

A2W005G	2.0	50	20	50	100	550	50	1.0	1.0	10
A2W01G	2.0	50	40	100	150	600	50	1.0	1.0	10
A2W02G	2.0	50	80	200	250	700	50	1.0	1.0	10
A2W04G	2.0	50	125	400	450	900	50	1.0	1.0	10
A2W06G	2.0	50	250	600	700	1150	50	1.0	1.0	10
A2W08G	2.0	50	380	800	900	1350	50	1.0	1.0	10
A2W10G	2.0	50	440	1000	1100	1550	50	1.0	1.0	10



Avalanche Bridge Rectifiers

The plastic material carries U/L recognition 94V-O.

Type No.	Max. Average Forward Rectified Current		Input Voltage Recommended	Max. Recurrent Peak Reverse Voltage	Avalanche Breakdown Voltage at 100 mA		Max. Forward Peak Surge Current	Max. Forward Voltage Drop at Ta = 25°C		Max. Reverse Current at Ta = 25°C
	IF(AV) @	Tc			Min.	Max.		IFSM	VF @	
	(A)	(°C)	(V)	(V)			(V)			(V)

AKBP200 Series, 2 A, Case Type: KBP



AKBP200	2.0	50	20	50	100	550	50	1.0	1.0	10
AKBP201	2.0	50	40	100	150	600	50	1.0	1.0	10
AKBP202	2.0	50	80	200	250	700	50	1.0	1.0	10
AKBP204	2.0	50	125	400	450	900	50	1.0	1.0	10
AKBP206	2.0	50	250	600	700	1150	50	1.0	1.0	10
AKBP208	2.0	50	380	800	900	1350	50	1.0	1.0	10
AKBP210	2.0	50	440	1000	1100	1550	50	1.0	1.0	10

AKBL400 Series, 4 A, Case Type: KBL



AKBL400	4.0	50	20	50	100	550	200	1.1	4.0	10
AKBL401	4.0	50	40	100	150	600	200	1.1	4.0	10
AKBL402	4.0	50	80	200	250	700	200	1.1	4.0	10
AKBL404	4.0	50	125	400	450	900	200	1.1	4.0	10
AKBL406	4.0	50	250	600	700	1150	200	1.1	4.0	10
AKBL408	4.0	50	380	800	900	1350	200	1.1	4.0	10
AKBL410	4.0	50	440	1000	1100	1550	200	1.1	4.0	10

ABR600 Series, 6 A, Case Type: BR6



ABR600	6.0	50	20	50	100	550	200	1.0	3.0	10
ABR601	6.0	50	40	100	150	600	200	1.0	3.0	10
ABR602	6.0	50	80	200	250	700	200	1.0	3.0	10
ABR604	6.0	50	125	400	450	900	200	1.0	3.0	10
ABR606	6.0	50	250	600	700	1150	200	1.0	3.0	10
ABR608	6.0	50	380	800	900	1350	200	1.0	3.0	10
ABR610	6.0	50	440	1000	1100	1550	200	1.0	3.0	10

ABR800 Series, 8 A, Case Type: BR10



ABR800	8.0	50	20	50	100	550	300	1.0	4.0	10
ABR801	8.0	50	40	100	150	600	300	1.0	4.0	10
ABR802	8.0	50	80	200	250	700	300	1.0	4.0	10
ABR804	8.0	50	125	400	450	900	300	1.0	4.0	10
ABR806	8.0	50	250	600	700	1150	300	1.0	4.0	10
ABR808	8.0	50	380	800	900	1350	300	1.0	4.0	10
ABR810	8.0	50	440	1000	1100	1550	300	1.0	4.0	10



Avalanche Bridge Rectifiers

The plastic material carries U/L recognition 94V-O.

Type No.	Max. Average Forward Rectified Current		Input Voltage Recommended	Max. Recurrent Peak Reverse Voltage	Avalanche Breakdown Voltage at 100 mA		Max. Forward Peak Surge Current	Max. Forward Voltage Drop at Ta = 25°C		Max. Reverse Current at Ta = 25°C
	IF(AV)	@ Tc			Min.	Max.		IFSM	VF @ IF	
	(A)	(°C)	(V)	(V)			(V)			(V)

ABR1000 Series, 10 A, Case Type: BR10

ABR1000	10	50	20	50	100	550	300	1.0	5.0	10
ABR1001	10	50	40	100	150	600	300	1.0	5.0	10
ABR1002	10	50	80	200	250	700	300	1.0	5.0	10
ABR1004	10	50	125	400	450	900	300	1.0	5.0	10
ABR1006	10	50	250	600	700	1150	300	1.0	5.0	10
ABR1008	10	50	380	800	900	1350	300	1.0	5.0	10
ABR1010	10	50	440	1000	1100	1550	300	1.0	5.0	10

ABR1500 Series, 15 A, Case Type: BR50

ABR1500	15	55	20	50	100	550	300	1.1	7.5	10
ABR1501	15	55	40	100	150	600	300	1.1	7.5	10
ABR1502	15	55	80	200	250	700	300	1.1	7.5	10
ABR1504	15	55	125	400	450	900	300	1.1	7.5	10
ABR1506	15	55	250	600	700	1150	300	1.1	7.5	10
ABR1508	15	55	380	800	900	1350	300	1.1	7.5	10
ABR1510	15	55	440	1000	1100	1550	300	1.1	7.5	10

* For wire leads use suffix "W" for Case Type : BR50W

ABR2500 Series, 25 A, Case Type: BR50

ABR2500	25	55	20	50	100	550	300	1.1	12.5	10
ABR2501	25	55	40	100	150	600	300	1.1	12.5	10
ABR2502	25	55	80	200	250	700	300	1.1	12.5	10
ABR2504	25	55	125	400	450	900	300	1.1	12.5	10
ABR2506	25	55	250	600	700	1150	300	1.1	12.5	10
ABR2508	25	55	380	800	900	1350	300	1.1	12.5	10
ABR2510	25	55	440	1000	1100	1550	300	1.1	12.5	10

* For wire leads use suffix "W" for Case Type : BR50W



BR10



BR50



BR50W



Avalanche Bridge Rectifiers

The plastic material carries U/L recognition 94V-O.

Type No.	Max. Average Forward Rectified Current		Input Voltage Recommended	Max. Recurrent Peak Reverse Voltage	Avalanche Breakdown Voltage at 100 mA		Max. Forward Peak Surge Current	Max. Forward Voltage Drop at Ta = 25°C		Max. Reverse Current at Ta = 25°C
	IF(AV)	@ Tc			Min.	Max.		VF @ IF	IF	
	(A)	(°C)	(V)	(V)	(V)	(V)	(A)	(V)	(A)	(μA)

ABR3500 Series, 35 A, Case Type: BR50

ABR3500	35	55	20	50	100	550	300	1.1	17.5	10
ABR3501	35	55	40	100	150	600	300	1.1	17.5	10
ABR3502	35	55	80	200	250	700	300	1.1	17.5	10
ABR3504	35	55	125	400	450	900	300	1.1	17.5	10
ABR3506	35	55	250	600	700	1150	300	1.1	17.5	10
ABR3508	35	55	380	800	900	1350	300	1.1	17.5	10
ABR3510	35	55	440	1000	1100	1550	300	1.1	17.5	10

* For wire leads use suffix "W" for Case Type : BR50W

ABR5000 Series, 50 A, Case Type: BR50

ABR5000	50	55	20	50	100	550	400	1.1	25	10
ABR5001	50	55	40	100	150	600	400	1.1	25	10
ABR5002	50	55	80	200	250	700	400	1.1	25	10
ABR5004	50	55	125	400	450	900	400	1.1	25	10
ABR5006	50	55	250	600	700	1150	400	1.1	25	10
ABR5008	50	55	380	800	900	1350	400	1.1	25	10
ABR5010	50	55	440	1000	1100	1550	400	1.1	25	10

* For wire leads use suffix "W" for Case Type : BR50W



BR50



BR50W



Fast Recovery Glass Passivated Bridge Rectifiers

The plastic material carries U/L recognition 94V-0.

Type No.	Maximum Average Forward Rectified Current		Input Voltage Recommended	Max. Repetitive Peak Forward Voltage	Max. Peak Forward Surge Current	Max. Forward Voltage Drop at Ta = 25°C		Max. Reverse Current at Ta = 25°C	Max. Reverse Recovery Time ⁽¹⁾
	I _{F(AV)} (A)	@ T _c (°C)				V _F (V)	I _F (A)		

FB40-C1000G Series, 1 A, Case Type: WOB



FB40-C1000G	1.0	45	40	100	30	1.3	1.0	10	150
FB80-C1000G	1.0	45	80	200	30	1.3	1.0	10	150
FB125-C1000G	1.0	45	125	300	30	1.3	1.0	10	150
FB250-C1000G	1.0	45	250	600	30	1.3	1.0	10	250
FB380-C1000G	1.0	45	380	900	30	1.3	1.0	10	500

FB40-C1500RG Series, 1.5 A, Case Type: WOB



FB40-C1500RG	1.5	45	40	100	30	1.4	1.5	10	150
FB80-C1500RG	1.5	45	80	200	30	1.4	1.5	10	150
FB125-C1500RG	1.5	45	125	300	30	1.4	1.5	10	150
FB250-C1500RG	1.5	45	250	600	30	1.4	1.5	10	250
FB380-C1500RG	1.5	45	380	900	30	1.4	1.5	10	500

FWL005G Series, 1 A, Case Type: WOB



FWL005G	1.0	50	20	50	30	1.3	1.0	10	150
FWL01G	1.0	50	40	100	30	1.3	1.0	10	150
FWL02G	1.0	50	80	200	30	1.3	1.0	10	150
FWL04G	1.0	50	125	400	30	1.3	1.0	10	150
FWL06G	1.0	50	250	600	30	1.3	1.0	10	250
FWL08G	1.0	50	380	800	30	1.3	1.0	10	500
FWL10G	1.0	50	440	1000	30	1.3	1.0	10	500

FW005G Series, 1.5 A, Case Type: WOB



FW005G	1.5	25	20	50	30	1.3	1.0	10	150
FW01G	1.5	25	40	100	30	1.3	1.0	10	150
FW02G	1.5	25	80	200	30	1.3	1.0	10	150
FW04G	1.5	25	125	400	30	1.3	1.0	10	150
FW06G	1.5	25	250	600	30	1.3	1.0	10	250
FW08G	1.5	25	380	800	30	1.3	1.0	10	500
FW10G	1.5	25	440	1000	30	1.3	1.0	10	500

F2W005G Series, 2 A, Case Type: WOB



F2W005G	2.0	50	20	50	30	1.3	1.0	10	150
F2W01G	2.0	50	40	100	30	1.3	1.0	10	150
F2W02G	2.0	50	80	200	30	1.3	1.0	10	150
F2W04G	2.0	50	125	400	30	1.3	1.0	10	150
F2W06G	2.0	50	250	600	30	1.3	1.0	10	250
F2W08G	2.0	50	380	800	30	1.3	1.0	10	500
F2W10G	2.0	50	440	1000	30	1.3	1.0	10	500

Note : (1) Reverse Recovery test conditions : I_F = 0.5 A, I_R = 1 A, I_{rr} = 0.25 A



Fast Recovery Bridge Rectifiers

The plastic material carries U/L recognition 94V-0.

Type No.	Maximum Average Forward Rectified Current		Input Voltage Recommended	Max. Repetitive Peak Forward Voltage V_{RRM}	Max. Peak Forward Surge Current I_{FSM}	Max. Forward Voltage Drop at $T_a = 25^\circ\text{C}$		Max. Reverse Current at $T_a = 25^\circ\text{C}$ I_R	Max. Reverse Recovery Time ⁽¹⁾ T_{rr}
	$I_F(AV)$	@ T_c				V_F	@ I_F		
	(A)	($^\circ\text{C}$)	(V)	(V)	(A)	(V)	(μA)	(ns)	

FKBP200 Series, 2 A, Case Type: KBP



FKBP200	2.0	50	20	50	35	1.3	1.0	10	150
FKBP201	2.0	50	40	100	35	1.3	1.0	10	150
FKBP202	2.0	50	80	200	35	1.3	1.0	10	150
FKBP204	2.0	50	125	400	35	1.3	1.0	10	150
FKBP206	2.0	50	250	600	35	1.3	1.0	10	250
FKBP208	2.0	50	380	800	35	1.3	1.0	10	500
FKBP210	2.0	50	440	1000	35	1.3	1.0	10	500

FKBL400 Series, 4 A, Case Type: KBL



FKBL400	4.0	50	20	50	150	1.4	4.0	10	150
FKBL401	4.0	50	40	100	150	1.4	4.0	10	150
FKBL402	4.0	50	80	200	150	1.4	4.0	10	150
FKBL404	4.0	50	125	400	150	1.4	4.0	10	150
FKBL406	4.0	50	250	600	150	1.4	4.0	10	250
FKBL408	4.0	50	380	800	150	1.4	4.0	10	500
FKBL410	4.0	50	440	1000	150	1.4	4.0	10	500

FBR600 Series, 6 A, Case Type: BR6



FBR600	6.0	50	20	50	150	1.3	3.0	10	150
FBR601	6.0	50	40	100	150	1.3	3.0	10	150
FBR602	6.0	50	80	200	150	1.3	3.0	10	150
FBR604	6.0	50	125	400	150	1.3	3.0	10	150
FBR606	6.0	50	250	600	150	1.3	3.0	10	250
FBR608	6.0	50	380	800	150	1.3	3.0	10	500
FBR610	6.0	50	440	1000	150	1.3	3.0	10	500

FKBP800 Series, 8 A, Case Type: BR10

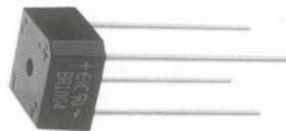

FBR800	8.0	50	20	50	200	1.3	4.0	10	150
FBR801	8.0	50	40	100	200	1.3	4.0	10	150
FBR802	8.0	50	80	200	200	1.3	4.0	10	150
FBR804	8.0	50	125	400	200	1.3	4.0	10	150
FBR806	8.0	50	250	600	200	1.3	4.0	10	250
FBR808	8.0	50	380	800	200	1.3	4.0	10	500
FBR810	8.0	50	440	1000	200	1.3	4.0	10	500

Note :

(1) Reverse Recovery test conditions : $I_F = 0.5 \text{ A}$, $I_R = 1 \text{ A}$, $I_{rr} = 0.25 \text{ A}$



Fast Recovery Bridge Rectifiers

The plastic material carries U/L recognition 94V-0.

Type No.	Maximum Average Forward Rectified Current		Input Voltage Recommended	Max. Repetitive Peak Forward Voltage	Max. Peak Forward Surge Current	Max. Forward Voltage Drop at Ta = 25°C		Max. Reverse Current at Ta = 25°C	Max. Reverse Recovery Time ⁽¹⁾
	I _{F(AV)}	@ T _c				V _F	@ I _F		
	(A)	(°C)	(V)	(V)	(A)	(V)	(A)	(μA)	(ns)

FBR1000 Series, 10 A, Case Type: BR10

FBR1000	10	55	20	50	250	1.3	5.0	10	150
FBR1001	10	55	40	100	250	1.3	5.0	10	150
FBR1002	10	55	80	200	250	1.3	5.0	10	150
FBR1004	10	55	125	400	250	1.3	5.0	10	150
FBR1006	10	55	250	600	250	1.3	5.0	10	250
FBR1008	10	55	380	800	250	1.3	5.0	10	500
FBR1010	10	55	440	1000	250	1.3	5.0	10	500

FBR1500 Series, 15 A, Case Type: BR50

FBR1500	15	55	20	50	300	1.3	7.5	10	150
FBR1501	15	55	40	100	300	1.3	7.5	10	150
FBR1502	15	55	80	200	300	1.3	7.5	10	150
FBR1504	15	55	125	400	300	1.3	7.5	10	150
FBR1506	15	55	250	600	300	1.3	7.5	10	250
FBR1508	15	55	380	800	300	1.3	7.5	10	500
FBR1510	15	55	440	1000	300	1.3	7.5	10	500

* For wire leads use suffix "W" for Case Type : BR50W

FBR2500 Series, 25 A, Case Type: BR50

FBR2500	25	55	20	50	300	1.3	12.5	10	150
FBR2501	25	55	40	100	300	1.3	12.5	10	150
FBR2502	25	55	80	200	300	1.3	12.5	10	150
FBR2504	25	55	125	400	300	1.3	12.5	10	150
FBR2506	25	55	250	600	300	1.3	12.5	10	250
FBR2508	25	55	380	800	300	1.3	12.5	10	500
FBR2510	25	55	440	1000	300	1.3	12.5	10	500

* For wire leads use suffix "W" for Case Type : BR50W

Note :

(1) Reverse Recovery test conditions : I_F = 0.5 A, I_R = 1 A, I_{rr} = 0.25 A



BR10



BR50



BR50W



Fast Recovery Bridge Rectifiers

The plastic material carries U/L recognition 94V-0.

Type No.	Maximum Average Forward Rectified Current		Input Voltage Recommended	Max. Repetitive Peak Forward Voltage	Max. Peak Forward Surge Current	Max. Forward Voltage Drop at Ta = 25°C		Max. Reverse Current at Ta = 25°C	Max. Reverse Recovery Time ⁽¹⁾
	I _{F(AV)}	@ T _c				V _F	@ I _F		
	(A)	(°C)	(V)	(V)	(A)	(V)	(A)	(μA)	(ns)

FBR3500 Series, 35 A, Case Type: BR50

FBR3500	35	55	20	50	400	1.3	17.5	10	150
FBR3501	35	55	40	100	400	1.3	17.5	10	150
FBR3502	35	55	80	200	400	1.3	17.5	10	150
FBR3504	35	55	125	400	400	1.3	17.5	10	150
FBR3506	35	55	250	600	400	1.3	17.5	10	250
FBR3508	35	55	380	800	400	1.3	17.5	10	500
FBR3510	35	55	440	1000	400	1.3	17.5	10	500

* For wire leads use suffix "W" for Case Type : BR50W

FBR5000 Series, 50 A, Case Type: BR50

FBR5000	50	55	20	50	400	1.3	25	10	150
FBR5001	50	55	40	100	400	1.3	25	10	150
FBR5002	50	55	80	200	400	1.3	25	10	150
FBR5004	50	55	125	400	400	1.3	25	10	150
FBR5006	50	55	250	600	400	1.3	25	10	250
FBR5008	50	55	380	800	400	1.3	25	10	500
FBR5010	50	55	440	1000	400	1.3	25	10	500

* For wire leads use suffix "W" for Case Type : BR50W

Note :

(1) Reverse Recovery test conditions : I_F = 0.5 A, I_R = 1 A, I_{rr} = 0.25 A



BR50



BR50W



Bi - Directional trigger - DIACS

The plastic material carries U/L recognition 94V-O.

Type No.	Breakdown Voltage			Breakover Voltage Symmetry	Dynamic Breakback Voltage	Breakover Current	Peak Pulse Current for 10 μ s 120 PPS Ta < 40 °C
	V _{(BR)1} and V _{(BR)2}			[V _{(BR)1}] - [V _{(BR)2}]	Δ V \pm	I _{(BR)1} and I _{(BR)2}	ITRM
	V(Min.)	V(Typ.)	V(Max.)	V(Max)	V(Min.)	μ A(Max.)	A(Max.)

D32P Series, Case Type: DO-41



Part No.	V _{(BR)1} (Min.)	V _{(BR)1} (Typ.)	V _{(BR)1} (Max.)	Breakover Voltage Symmetry	Dynamic Breakback Voltage	Breakover Current	Peak Pulse Current
D32P	27	32	37	3.0	5.0	100	2.0
D35P	30	35	40	3.0	5.0	100	2.0
D40P	35	40	45	3.0	5.0	100	2.0
D50P	42	50	58	4.0	8.0	100	1.6
D60P	56	60	70	4.0	10.0	100	1.6

DB3 & DB4, Case Type: DO-35



Part No.	V _{(BR)1} (Min.)	V _{(BR)1} (Typ.)	V _{(BR)1} (Max.)	Breakover Voltage Symmetry	Dynamic Breakback Voltage	Breakover Current	Peak Pulse Current
DB3	28	32	36	3.8	5.0	200	2.0
DB4	35	40	45	3.8	5.0	200	2.0

Thyristor - SIDAC

The plastic material carries U/L recognition 94V-O.

Type No.	Repetitive Peak Off-State Voltage	Breakover Voltage (60 Hz Sine Wave)		On-State RMS Current Conduction Angle of 360°	Peak Surge (Non-Repetitive) On-State Current One-cycle@ 60 Hz	Repetitive Peak Off-State Current @ 60Hz, V=V _{DRM}	Dynamic Holding Current R=0.1 K Ω ,60Hz	Breakover Current 60 Hz Sine Wave
	V _{DRM}	V _{BO} (Min.)	V _{BO} (Max.)	I _T (RMS)	I _{TSM}	I _{DRM}	I _{HO}	I _{BO}
	(V)	(V)	(V)	(A)	(A)	(μ A)	(mA)	(μ A)

ET013 Series, Case Type: DO-41



Part No.	V _{DRM}	V _{BO} (Min.)	V _{BO} (Max.)	I _T (RMS)	I _{TSM}	I _{DRM}	I _{HO}	I _{BO}
ET013	\pm 90	120	138	0.6	20	10	100	200
ET015	\pm 115	142	157	0.6	20	10	100	200
ET020	\pm 170	190	200	0.6	20	10	100	200

G105 Series, Case Type: DO-41



Part No.	V _{DRM}	V _{BO} (Min.)	V _{BO} (Max.)	I _T (RMS)	I _{TSM}	I _{DRM}	I _{HO}	I _{BO}
G105*	\pm 90	95	113	1.0	20	10	100	200
G120*	\pm 90	110	125	1.0	20	10	100	200
G130	\pm 90	120	135	1.0	20	10	100	200
G220*	\pm 180	205	230	1.0	20	10	100	200
G240*	\pm 180	220	250	1.0	20	10	100	200
G260	\pm 180	240	270	1.0	20	10	100	200
G270*	\pm 180	250	280	1.0	20	10	100	200

* Also available in Axial D2A Case Types. Use suffix "C" to order(e.g. G105C, G120C,...).



Packaging Information

Case Type	Packaging	Quantity per unit (Pcs.)	Package size [mm. (inches)]	Quantity per carton (Pcs.)	Net weight per carton (Kgs.)	Gross weight per carton (Kgs.)	Carton size [mm. (inches)]
R-1	BULK	1,000	205x90x21 (8.07x3.54x0.82)	50,000	10.00	12.65	215x450x240 (8.46x17.71x9.45)
	TAPE & AMMO (26 mm)	3,000	45x255x78 (2.76x10.04x4.72)	39,000	5.30	7.30	260x370x150 (10.24x14.57x5.90)
	TAPE & AMMO(52 mm)	5,000	72x255x135 (2.83x10.04x5.32)	25,000	5.00	6.00	260x370x150 (10.24x14.57x5.90)
M1A	BULK	1,000	205x90x21 (8.07x3.54x0.82)	50,000	10.00	12.00	215x450x240 (8.46x17.71x9.45)
	TAPE&AMMO (26 mm)	5,000	45x255x78 (1.77x10.04x3.07)	65,000	12.80	14.10	260x370x150 (10.24x14.57x5.90)
DO-34 (Glass)	BULK	2,000	205x90x21 (8.07x3.54x0.82)	100,000	9.30	11.75	215x450x240 (8.46x17.71x9.45)
	TAPE & REEL	10,000	φ 330x81 (φ 12.992x3.189)	40,000	3.72	6.45	340x340x325 (13.39x13.39x12.79)
	TAPE & AMMO (26 mm)	5,000	45x255x78 (1.77x10.04x3.07)	65,000	5.30	6.30	260x370x150 (10.24x14.57x5.90)
	TAPE & AMMO (52 mm)	10,000	72x255x135 (2.83x10.04x5.32)	50,000	4.65	6.05	260x370x150 (10.24x14.57x5.90)
	BAG(500Pcs) & BULK	5,000	115x155x45 (4.53x6.10x1.78)	100,000	9.30	11.00	250x325x240 (9.84x12.80x9.45)
DO-35 (Glass)	BULK	2,000	205x90x21 (8.07x3.54x0.82)	100,000	12.70	15.10	215x450x240 (8.46x17.71x9.45)
	TAPE & REEL	10,000	φ 330x81 (φ 12.992x3.189)	40,000	5.08	7.80	340x340x325 (13.39x13.39x12.79)
	TAPE & AMMO (26 mm)	5,000	45x255x78 (1.77x10.04x3.07)	65,000	6.20	8.00	260x370x150 (10.24x14.57x5.90)
	TAPE & AMMO (52 mm)	10,000	72x255x135 (2.83x10.04x5.32)	50,000	6.35	7.75	260x370x150 (10.24x14.57x5.90)
	BAG(500Pcs) & BULK	5,000	92x170x50 (3.62x6.69x1.97)	100,000	12.70	14.60	185x395x285 (7.28x15.55x11.22)
DO-41 (Glass)	TAPE & REEL	5,000	φ 330x81 (φ 12.992x3.189)	20,000	5.10	7.30	340x340x325 (13.39x13.39x12.79)
	TAPE & AMMO (26 mm)	2,500	45x255x78 (1.77x10.04x3.07)	32,500	6.40	8.00	260x370x150 (10.24x14.57x5.90)
	TAPE & AMMO (52 mm)	5,000	72x255x135 (2.83x10.04x5.32)	25,000	6.38	7.45	260x370x150 (10.24x14.57x5.90)
	BAG(250Pcs) & BULK	2,500	92x170x50 (4.62x6.69x1.97)	50,000	12.75	14.65	250x325x240 (9.84x12.80x9.45)
DO-41	BULK	1,000	205x90x21 (8.07x3.54x0.82)	50,000	16.75	19.40	215x450x240 (8.46x17.71x9.45)
	TAPE & REEL	5,000	φ 330x81 (φ 12.992x3.189)	20,000	6.70	9.20	340x340x325 (13.39x13.39x12.78)
	TAPE & AMMO (26 mm)	2,000	45x255x78 (1.77x10.04x3.07)	26,000	5.90	7.00	260x370x150 (10.24x14.57x5.90)
	TAPE & AMMO (52 mm)	4,000	72x255x135 (2.83x10.04x5.32)	20,000	6.70	7.70	260x370x150 (10.24x14.57x5.90)
	TAPE & AMMO 120	3,000	72x255x120 (2.83x10.04x4.72)	15,000	5.03	6.00	260x370x140 (10.24x14.57x5.51)
	BAG(200Pcs) & AMMO	5,000	72x255x135 (2.83x10.04x5.32)	25,000	8.38	9.30	260x370x150 (10.24x14.57x5.90)



Packaging Information

Case Type	Packaging	Quantity per unit (Pcs.)	Package size [mm. (inches)]	Quantity per carton (Pcs.)	Net weight per carton (Kgs.)	Gross weight per carton (Kgs.)	Carton size [mm. (inches)]
D2	BULK	500	205x90x21 (6.07x3.54x0.82)	25,000	11.75	14.35	215x450x240 (8.46x17.71x9.45)
	TAPE & REEL	3,000	φ 330x81 (φ 12.992x3.189)	12,000	5.64	7.75	340x340x325 (13.39x13.39x12.80)
	TAPE & AMMO	2,000	72x255x135 (2.83x10.04x5.32)	10,000	4.70	5.65	260x370x150 (10.24x14.57x5.90)
	TAPE & AMMO 120	1,500	72x255x120 (2.83x10.04x4.72)	7,500	3.53	4.40	260x370x140 (10.24x14.57x5.51)
	BAG(100Pcs) & AMMO	2,500	72x255x135 (2.83x10.04x5.32)	12,500	5.88	6.85	260x370x150 (10.24x14.57x5.90)
D2A	BULK	500	200x84x20 (7.87x3.31x0.79)	25,000	15.95	18.55	215x450x240 (8.46x17.71x9.45)
	TAPE & REEL	3,000	φ 330x81 (φ 12.992x3.189)	12,000	7.66	9.75	340x340x325 (13.39x13.39x12.80)
	TAPE & AMMO	2,000	72x255x135 (2.83x10.04x5.32)	10,000	6.38	7.30	260x370x150 (10.24x14.57x5.90)
	BAG (100Pcs) & AMMO	2,500	72x255x135 (2.83x10.04x5.32)	12,500	7.98	8.95	260x370x150 (10.24x14.57x5.90)
DO-201	BULK	500	305x84x41 (12.0x3.30x1.61)	15,000	13.95	16.65	310x420x255 (12.20x16.54x10.04)
	TAPE & REEL	1,250	φ 330x81 (φ 12.992x3.189)	5,000	4.65	6.70	340x340x325 (13.39x13.39x12.80)
	TAPE & AMMO	1,000	72x255x135 (2.83x10.04x5.32)	5,000	4.65	5.60	260x370x150 (10.24x14.57x5.90)
	BAG (50Pcs) & AMMO	1,500	72x255x135 (2.83x10.04x5.32)	7,500	6.98	8.00	260x370x150 (10.24x14.57x5.90)
DO-201AD	BULK	500	305x84x41 (12.0x3.30x1.61)	15,000	17.22	19.95	310x420x255 (12.20x16.54x10.04)
	TAPE & REEL	1,250	φ 330x81 (φ 12.992x3.189)	5,000	5.74	7.80	340x340x325 (13.39x13.39x12.80)
	TAPE & AMMO	1,000	72x255x135 (2.83x10.04x5.32)	5,000	5.74	6.70	260x370x150 (10.24x14.57x5.90)
	BAG(50Pcs) & AMMO	1,500	72x255x135 (2.83x10.04x5.32)	7,500	8.61	9.60	260x370x150 (10.24x14.57x5.90)
D6	BULK	200	305x84x41 (12.0x3.30x1.61)	6,000	12.29	15.00	310x420x255 (12.20x16.54x10.04)
	TAPE & REEL	800	φ 330x81 (φ 12.992x3.189)	3,200	6.56	8.45	340x340x325 (13.39x13.39x12.80)
MiniMELF	REEL	3,000	φ 178x14.4 (φ 7.008x0.567)	120,000	3.72	6.90	215x405x265 (8.46x15.95x10.43)
	REEL	10,000	φ 330x14.4 (φ 12.992x0.567)	50,000	1.55	3.67	340x340x100 (13.39x13.39x3.94)
MELF	REEL	5,000	φ 330x14.4 (φ 12.992x0.567)	25,000	3.35	5.39	340x340x100 (13.39x13.39x3.94)
SMA(DO-214AC)	REEL	5,000	φ 330x18.4 (φ 12.992x0.724)	25,000	1.68	3.71	340x340x100 (13.39x13.39x3.94)
SMB(DO-214AA)	REEL	3,000	φ 330x18.4 (φ 12.992x0.724)	15,000	1.76	3.91	340x340x100 (13.39x13.39x3.94)
SMC(DO-214AB)	REEL	2,500	φ 330x22.4 (φ 12.992x0.882)	10,000	2.51	4.34	340x340x100 (13.39x13.39x3.94)
DO-215AC	REEL	3,000	φ 330x18.4 (φ 12.992x0.724)	15,000	1.68	3.83	340x340x100 (13.39x13.39x3.94)
DFS	REEL	1,500	φ 330x22.4 (φ 12.992x0.882)	7,500	2.85	4.45	340x340x100 (13.39x13.39x3.94)
MBS	REEL	2,500	φ 330x22.4 (φ 12.992x0.882)	15,000	1.28	2.45	340x340x100 (13.39x13.39x3.94)



Packaging Information

Case Type	Quantity per box (Pcs.)	Box size [mm. (inches)]	Quantity per carton (Pcs.)	Net weight per carton (Kgs.)	Gross weight per carton (Kgs.)	Carton size [mm. (inches)]
WOB	500	200x84x20 (7.87x7.87x1.85)	5,000	6.26	8.00	215x405x265 (8.46x15.95x10.43)
KBP	100	90x170x52 (3.54x6.69x1.97)	2,000	6.52	8.80	185x395x285 (7.28x15.55x11.22)
KBL	100	90x170x52 (3.54x6.69x1.97)	2,000	11.66	13.95	185x395x285 (7.28x15.55x11.22)
GBU	160	115x115x45 (4.53x6.10x1.77)	3,200	11.51	13.30	250x325x240 (9.84x12.80x9.45)
BR6	200	160x210x38 (6.30x8.27x1.50)	2,000	7.18	8.60	215x345x225 (8.46x13.58x8.86)
BR10	200	200x200x47 (7.87x7.87x1.85)	2,000	11.45	13.20	215x405x265 (8.46x15.95x10.43)
BR50	50	155x165x30 (6.10x6.50x1.18)	1,000	16.55	18.65	180x330x345 (7.09x12.99x13.58)
BR50W	40	155x165x30 (6.10x6.50x1.18)	800	12.52	14.60	180x330x345 (7.09x12.99x13.58)
BR50M	50	155x165x30 (6.10x6.50x1.18)	900	27.60	29.30	180x330x345 (7.09x12.99x13.58)
RBV4	120	115x155x45 (4.53x6.10x1.77)	2,400	10.27	12.10	250x325x240 (9.84x12.80x9.45)
RBV25	100	115x155x45 (4.53x6.10x1.77)	2,000	16.31	18.15	250x325x240 (9.84x12.80x9.45)
BUTTON CASE	2,000	72x255x120 (2.83x10.04x4.72)	10,000	18.18	19.00	260x370x140 (10.24x14.57x5.51)
MR	2,000	72x255x120 (2.83x10.04x4.72)	10,000	16.01	16.80	260x370x140 (10.24x14.57x5.51)
DFM	50	440 Length (17.4 Length)	Plastic Tubes			
MBM	100	70x250x135	Plastic Tubes			
TO-220AB, AC	50	Tube 32x520x6 (1.23x20.52x0.24)	1,000	1.95	2.81	140x540x85 (5.51x21.26x3.35)
	500	160x210x38 (6.50x8.27x1.50)	5,000	9.39	10.80	250x325x240 (9.84x12.80x9.45)
ITO-220AB, AC	50	Tube 32x520x6 (1.23x20.52x0.24)	1,000	1.75	2.60	140x540x85 (5.51x21.26x3.35)
	500	160x210x38 (6.30x8.27x1.50)	5,000	8.75	10.15	250x325x240 (9.84x12.80x9.45)
TO-247AD	120	90x170x52 (3.54x6.69x1.97)	2,400	15.08	17.35	185x395x285 (7.28x15.55x11.22)
D ² PAK	50	Tube 32x520x6 (1.23x20.52x0.24)	1,000	1.44	2.30	140x540x85 (5.51x21.26x3.35)
CELL 3A	10,000	Bottle ϕ 70x120 (ϕ 2.76x4.72)	100,000	9.20	10.00	260x370x150 (10.24x14.57x5.90)
CELL 5A	10,000	Bottle ϕ 70x120 (ϕ 2.76x4.72)	100,000	15.40	16.20	260x370x150 (10.24x14.57x5.90)
CELL 8A	5,000	Bottle ϕ 70x120 (ϕ 2.76x4.72)	50,000	9.75	10.55	260x370x150 (10.24x14.57x5.90)
CELL 18A	5,000	Bottle ϕ 70x120 (ϕ 2.76x4.72)	50,000	12.15	12.95	260x370x150 (10.24x14.57x5.90)
CELL 25A	5,000	Bottle ϕ 70x120 (ϕ 2.76x4.72)	50,000	12.55	13.35	260x370x150 (10.24x14.57x5.90)



Packaging Information

NEW PACKAGING (SURFACE MOUNT DIODES)

Package	Tape Width	Package size		Reel Size		Quantity per box (Pcs.)
	(mm)	(mm)	(inch)	(mm)	(inch)	
SOT-23	8	4.0 ± 0.1	0.157 ± 0.004	178	7	3,000
SOD-123	8	4.0 ± 0.1	0.157 ± 0.004	178	7	3,000
SOD-123FL	8	4.0 ± 0.1	0.157 ± 0.004	178	7	2,500
SOD-323	8	4.0 ± 0.1	0.157 ± 0.004	178	7	3,000
SOD-523	8	4.0 ± 0.1	0.157 ± 0.004	178	7	4,000
SOD-923	8	4.0 ± 0.1	0.157 ± 0.004	178	7	8,000
SOT-353	8	4.0 ± 0.1	0.157 ± 0.004	178	7	3,000
SOT-553	8	4.0 ± 0.1	0.157 ± 0.004	178	7	4,000
SOT-563	8	4.0 ± 0.1	0.157 ± 0.004	178	7	3,000
SOP-8	12	8.0 ± 0.1	0.315 ± 0.004	330	13	2,500

Packaging Information

TYPE DIMENSIONS (AXIAL LEAD DIODES)

CASE TYPE (Outline)	Type Dimensions			
	S	Δs	b	G
DO-34, DO-35, DO-41 (Glass), DO-41 (Plastic), R-1, M1A, D2, D2A	5 ± 0.5 (0.196 \pm 0.0196)	1.2(0.047)	6 ± 1.05 (0.236 \pm 0.039)	52 ± 1.50 (2.047 \pm 0.059)
DO-34, DO-35, DO-41 (Glass), DO-41 (Plastic), R-1, M1A, D2, D2A	5 ± 0.5 (0.196 \pm 0.0196)	1.2(0.047)	6 ± 1.05 (0.236 \pm 0.039)	26 ± 1.0 (1.023 \pm 0.039)
DO-201, DO-201AD, D6	10 ± 0.5 (0.393 \pm 0.0196)	1.2(0.047)	6 ± 1.05 (0.236 \pm 0.039)	52 ± 1.50 (2.047 \pm 0.059)

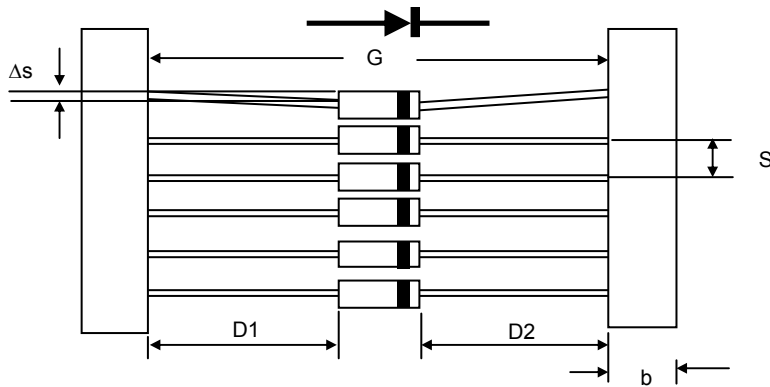

$$|D1 - D2| = 1.4 (0.055) \text{ max.}$$

Packaging Information

AMMOPACK PACKAGING (AXIAL LEAD DIODES)

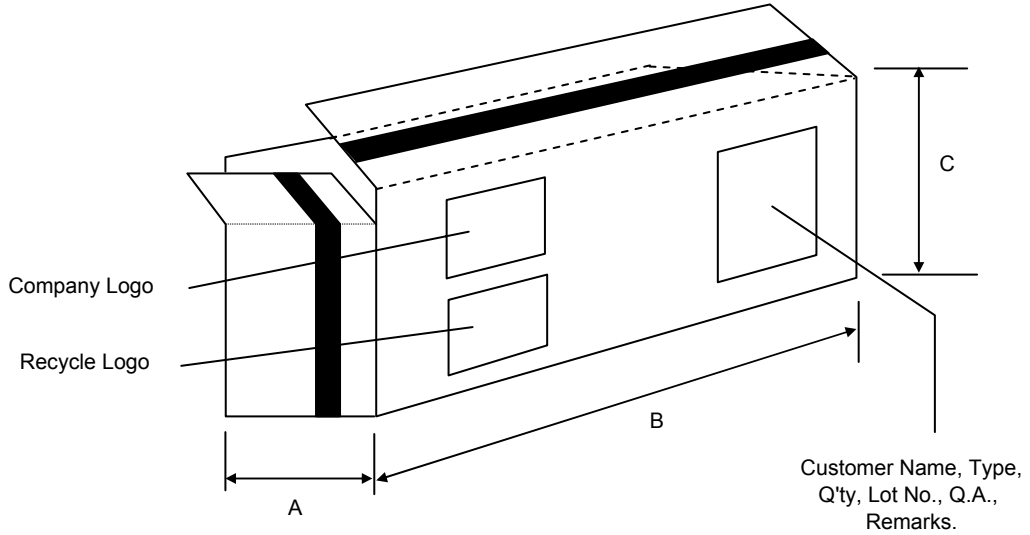

Packaging	Type Dimensions [mm. (inches)]		
	Dimension "A"	Dimension "B"	Dimension "C"
26mm Horizontal	45 ± 2.0 (1.771 \pm 0.079)	255 ± 2.0 (10.039 \pm 0.079)	78 ± 2.0 (3.070 \pm 0.079)
52mm Horizontal	72 ± 2.0 (2.834 \pm 0.079)	255 ± 2.0 (10.039 \pm 0.079)	135 ± 2.0 (5.314 \pm 0.079)

REEL PACKAGING (AXIAL LEAD DIODES)

DIMENSIONS IN mm. (inches)

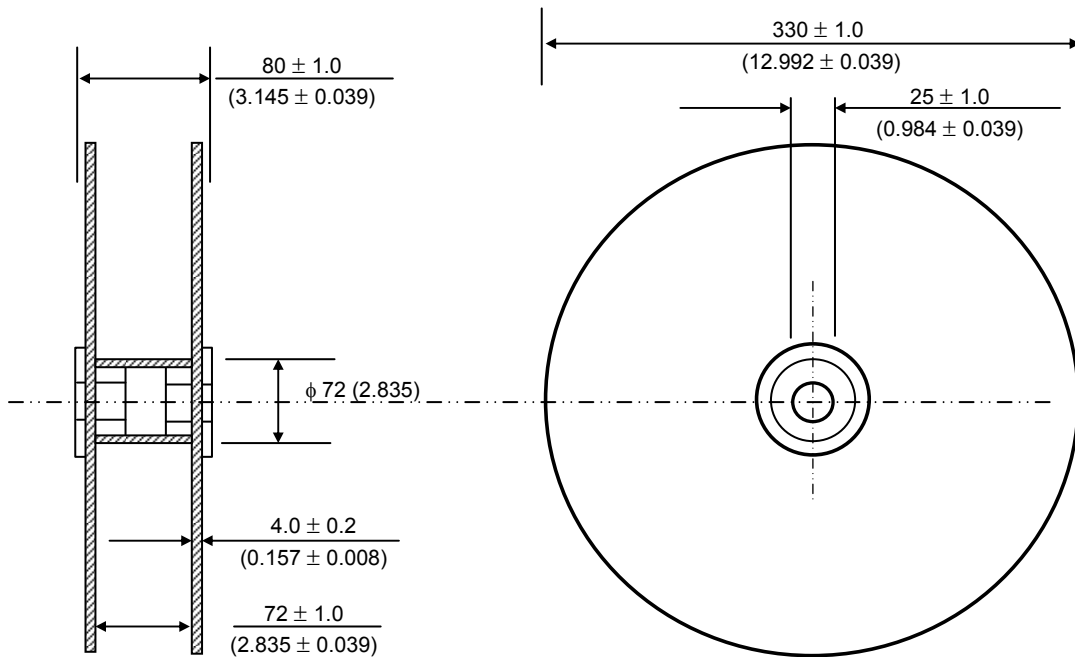

Packaging Information

SURFACE MOUNT TAPE AND REEL PACKAGING

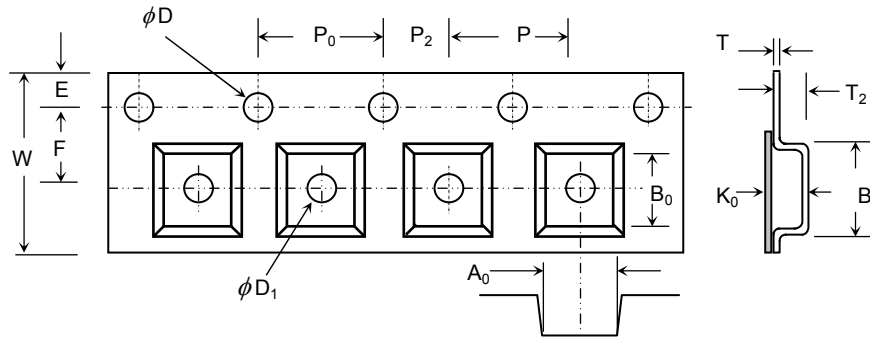

DIMENSIONS IN mm. (inches)

	Tape Size	D	E	P ₀	T Max.	A ₀ , B ₀ , K ₀	P ₂
	8, 12, 16mm.	1.50 ± 0.10 (0.059 ± 0.004)	1.75 ± 0.1 (0.069 ± 0.004)	4.00 ± 0.1 (0.157 ± 0.004)	0.600 (0.024)	See Note 1	2.00 ± 0.05 (0.079 ± 0.002)
Case Type	Tape Size	W	P	B ₁ Max.	F	T ₂ Max.	D ₁
MiniMELF, SOD-123, SOD-123FL, 323, 523 SOD-923, SOT-23 SOT-353, 556, 563	8mm.	8.00 ± 0.3 (0.314 ± 0.012)	4.00 ± 0.1 (0.157 ± 0.004)	4.2(0.165)	3.50 ± 0.05 (0.137 ± 0.002)	2.4(0.094)	1.00 ± 0.10 (0.039 ± 0.004)
MELF, SOP-8	12mm.	12.00 ± 0.3 (0.472 ± 0.012)	4.00 ± 0.1 (0.157 ± 0.004)	8.2(0.323)	5.50 ± 0.05 (0.217 ± 0.002)	4.5(0.177)	1.50 ± 0.25 (0.059 ± 0.001)
SMA	12mm.	12.00 ± 0.3 (0.472 ± 0.012)	4.00 ± 0.1 (0.157 ± 0.004)		5.50 ± 0.05 (0.217 ± 0.002)	2.54 ± 0.10 (0.100 ± 0.004)	1.50 ± 0.25 (0.059 ± 0.001)
SMB	12mm.	12.00 ± 0.3 (0.472 ± 0.012)	8.00 ± 0.1 (0.315 ± 0.004)		5.50 ± 0.05 (0.217 ± 0.002)	2.67 ± 0.10 (0.105 ± 0.004)	1.50 ± 0.25 (0.059 ± 0.001)
SMC, MBS	16mm.	16.00 ± 0.3 (0.629 ± 0.012)	8.00 ± 0.1 (0.315 ± 0.004)	12.1(0.476)	7.50 ± 0.1 (0.295 ± 0.004)	2.5 ± 0.10 (0.100 ± 0.004)	1.50 ± 0.25 (0.059 ± 0.001)
DFS	16mm.	16.00 ± 0.3 (0.629 ± 0.012)	12.00 ± 0.1 (0.473 ± 0.004)		7.50 ± 0.1 (0.295 ± 0.004)	3.8 ± 0.10 (0.150 ± 0.004)	1.50 ± 0.25 (0.059 ± 0.001)

Note:

1. A₀, B₀, and K₀ are determined by the maximum dimensions of the component size. The clearance between the component and the cavity must be within 0.05 mm (0.002") min. to 0.5 mm (0.02") max. for 8mm tape and 12mm tape and 0.15mm(0.006") min. to 0.90 mm (0.035") max. for 16 mm. tape.

Packaging Information

REEL PACKAGING (SURFACE MOUNT DIODES)

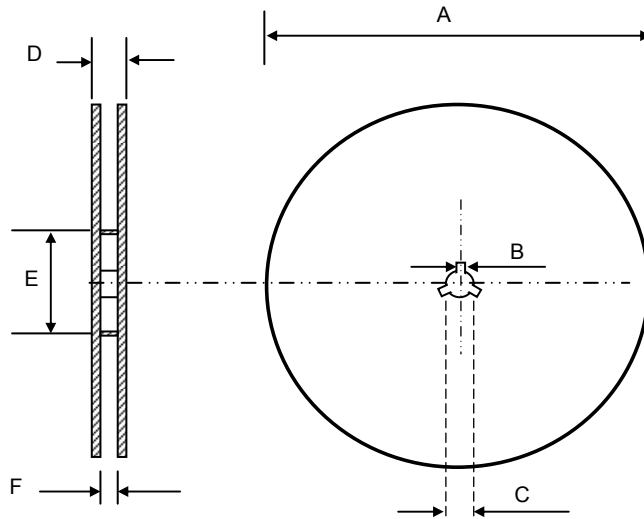

DIMENSIONS IN mm. (inches)

Tape Size	A max.	B max.	C	D max.	E min.	F max.
8 mm	178 ± 2.0 (7.0 ± 0.079)	2.5	13.0 ± 2.0	14.4	100	9.9
	330 ± 2.0 (13 ± 0.079)	(0.098)	(0.51 ± 0.079)	(0.567)	(3.94)	(0.389)
12 mm	330 ± 2.0 (13 ± 0.079)	2.5	13.0 ± 2.0	18.4	100	14.4
		(0.098)	(0.51 ± 0.079)	(0.724)	(3.94)	(0.567)
16 mm	330 ± 2.0 (13 ± 0.079)	2.5	13.0 ± 2.0	22.4	100	18.4
		(0.098)	(0.51 ± 0.079)	(0.802)	(3.94)	(0.724)

Package Outline

Dimension in inches and (millimeters)

Mini MELF(LL-34)

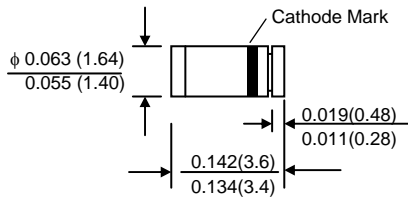

MELF(LL-41)

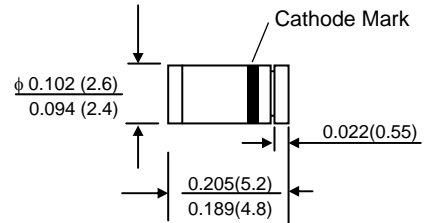

MELF (Plastic)

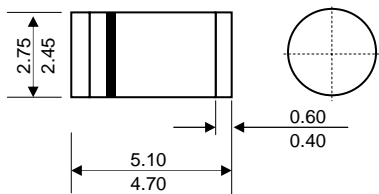

Dimensions in millimeters

SOT-23

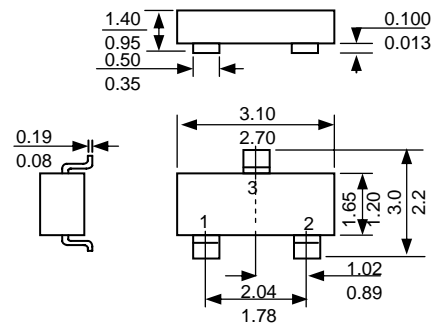

Dimensions in millimeters

SOD-123FL

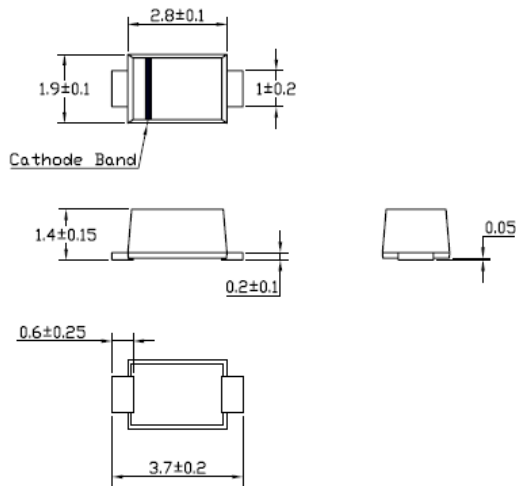

Dimensions in millimeters

SOD-123

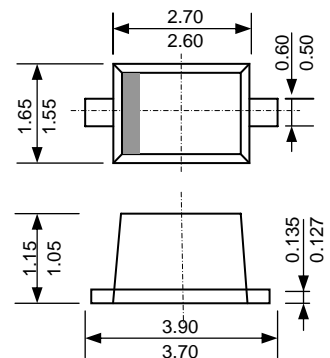

Dimensions in millimeters

Package Outline

Dimension in inches and (millimeters)

SOD-323

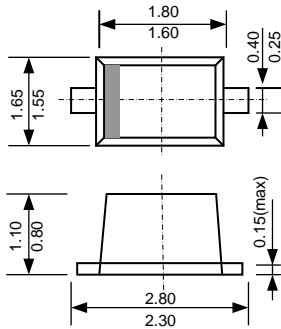

Dimensions in millimeters

SOD-523

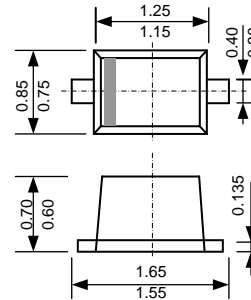

Dimensions in millimeters

DO-215AC

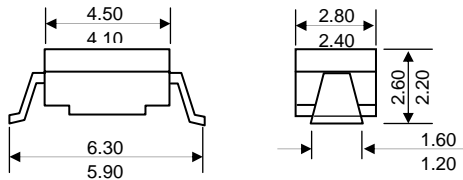

Dimensions in millimeters

SMA

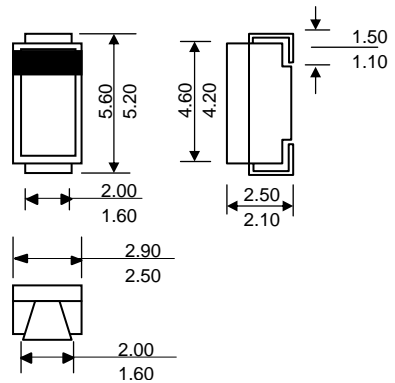

Dimensions in millimeters

SMA(DO-214AC)

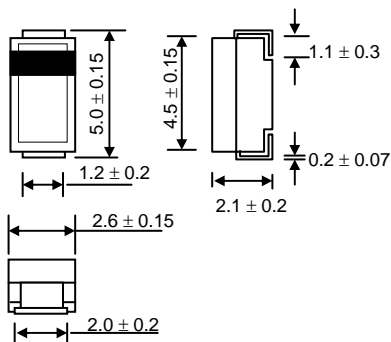

Dimensions in millimeters

SMB(DO-214AA)

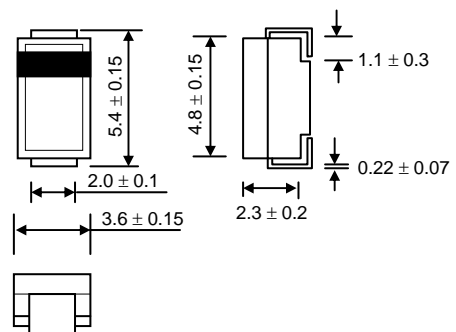

Dimensions in millimeters

Package Outline

Dimension in inches and (millimeters)

SMC(DO-214AB)

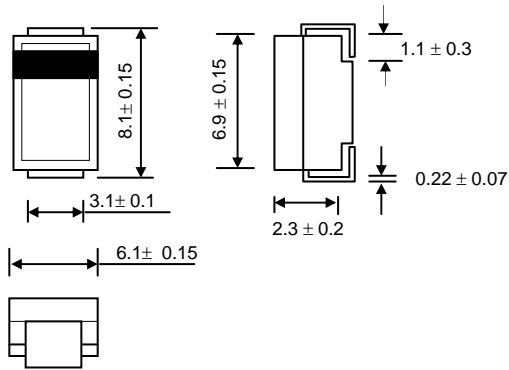

Dimensions in millimeters

DO-34

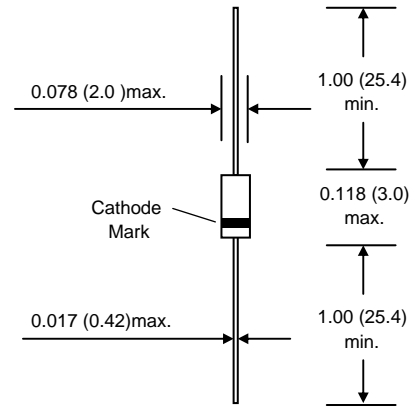

DO-35

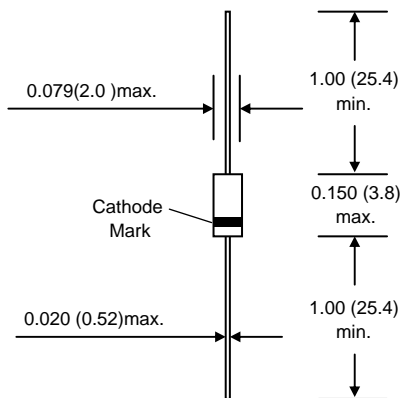

DO-41 Glass

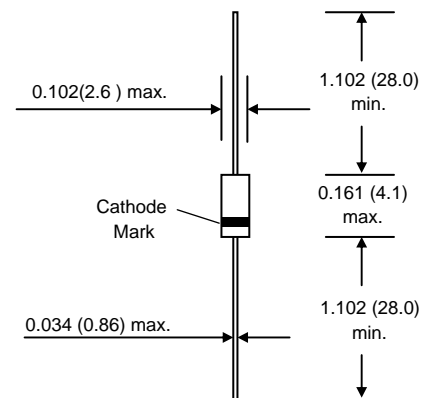

R-1

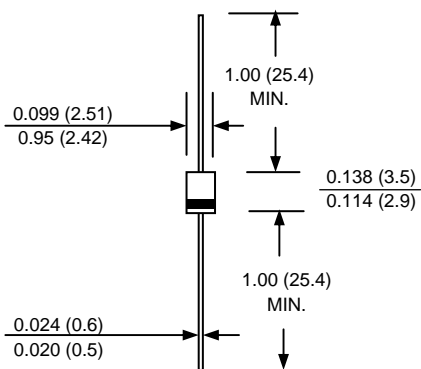

M1A

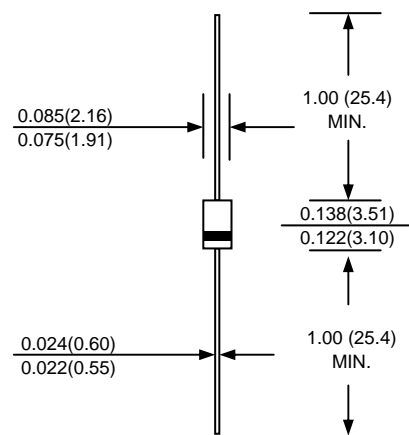

Package Outline

Dimension in inches and (millimeters)

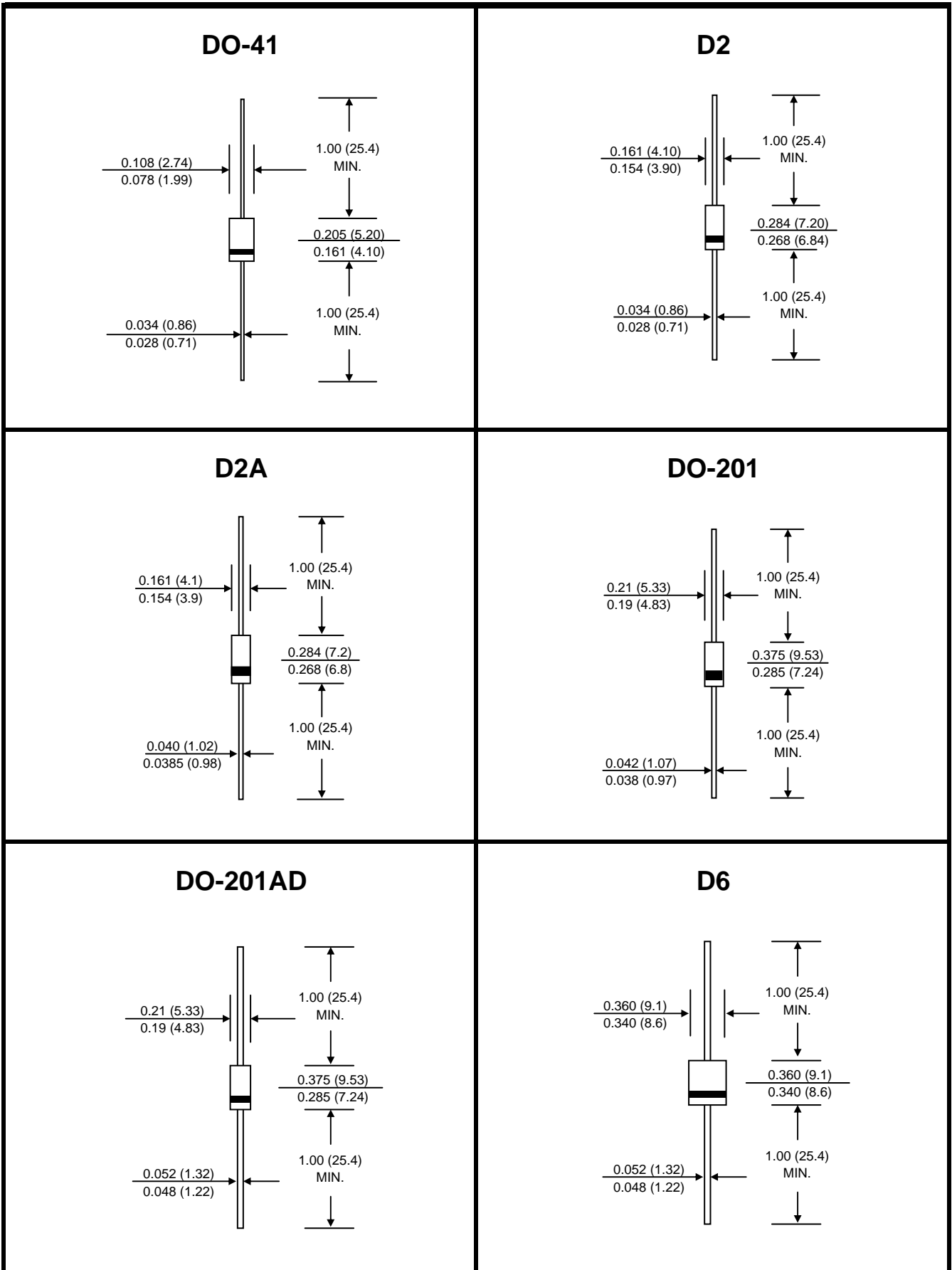

Package Outline

Dimension in inches and (millimeters)

BUTTON CASE

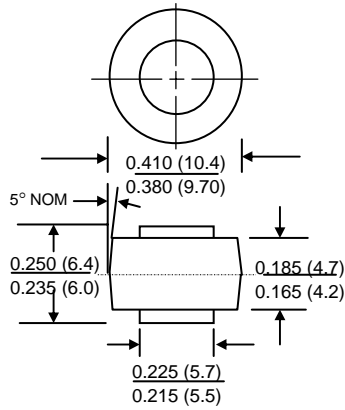

MR

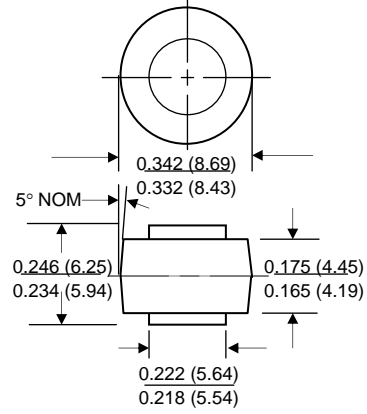

CELL

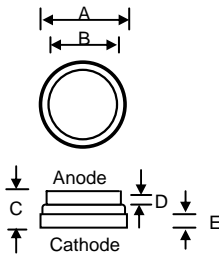

DIM.	MILLIMETER				
	3A	5A	8A	18A	25A
A	3.94	4.82	5.47	6.20	6.20
B	3.18	3.94	4.82	5.47	5.47
C	1.30	1.40	1.27	1.30	1.30
D	0.51	0.51	0.51	0.51	0.51
E	0.38	0.38	0.38	0.38	0.38

D²PAK

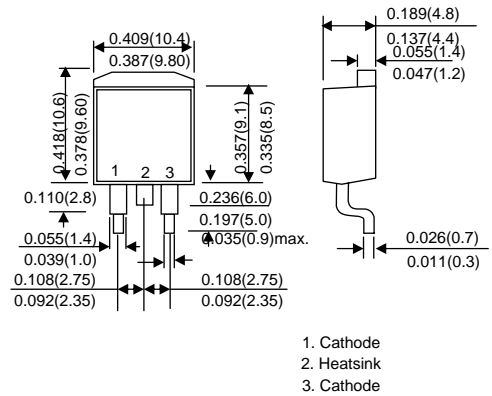

1. Cathode
2. Heatsink
3. Cathode

DFS

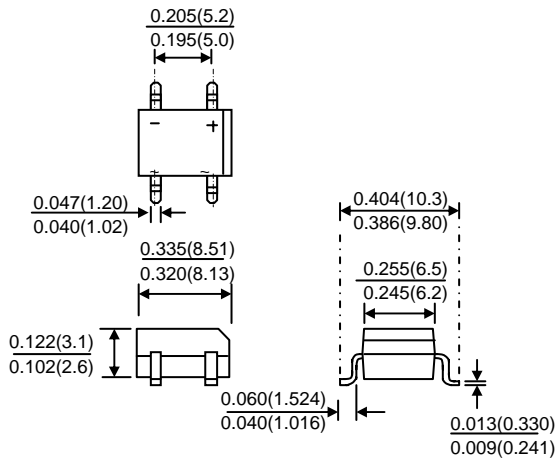

DFM

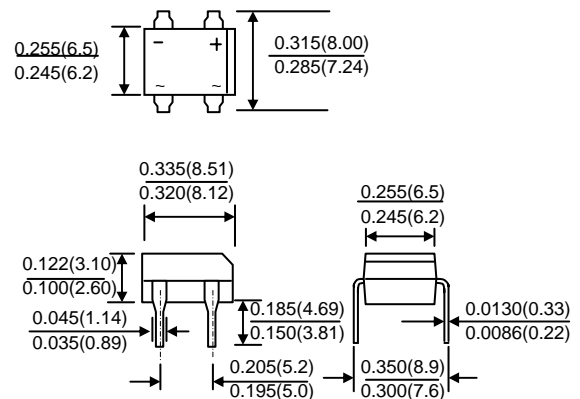

Package Outline

Dimension in inches and (millimeters)

MBS

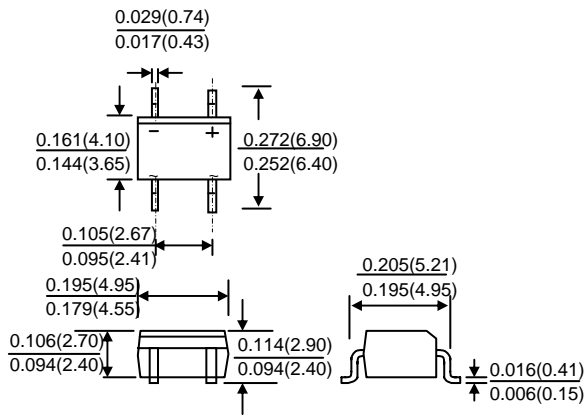

MBM

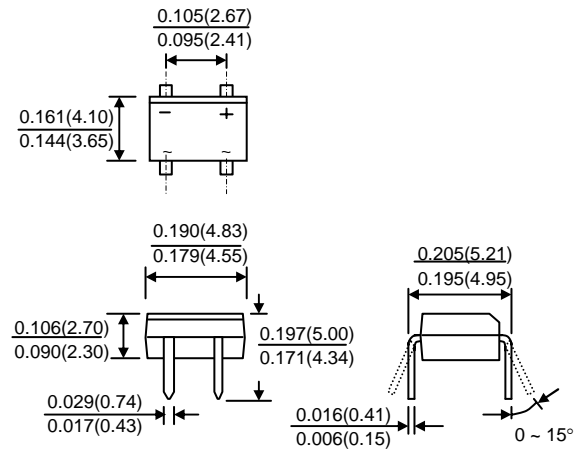

WOB

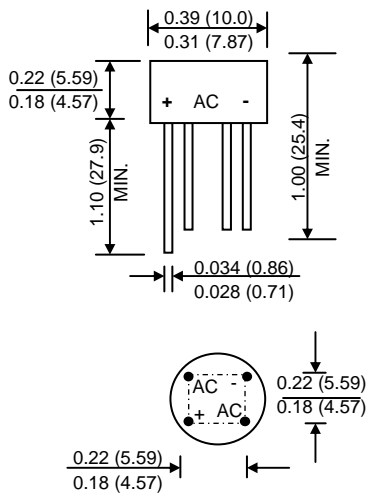

KBL

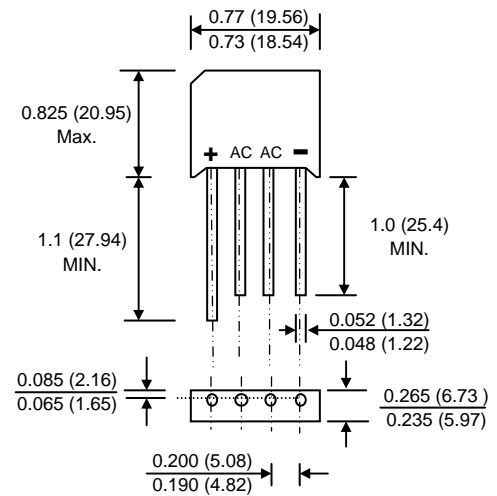

KBP

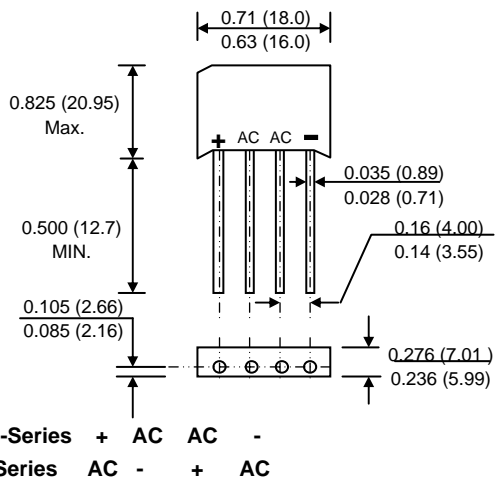

KBU

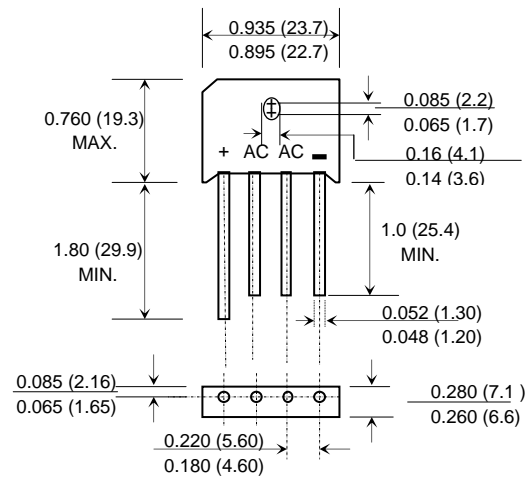

Package Outline

Dimension in inches and (millimeters)

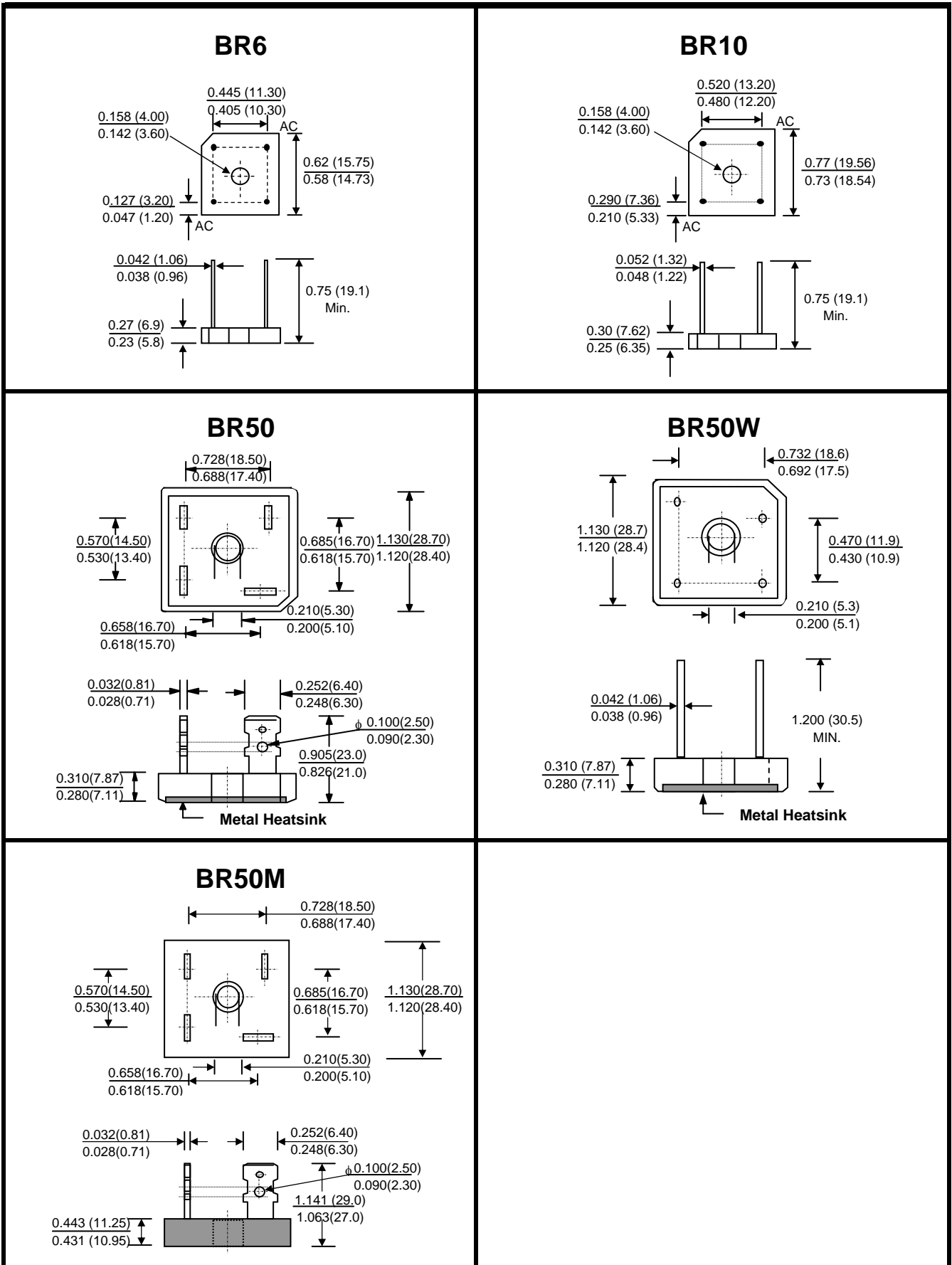

Package Outline

Dimension in inches and (millimeters)

GBU

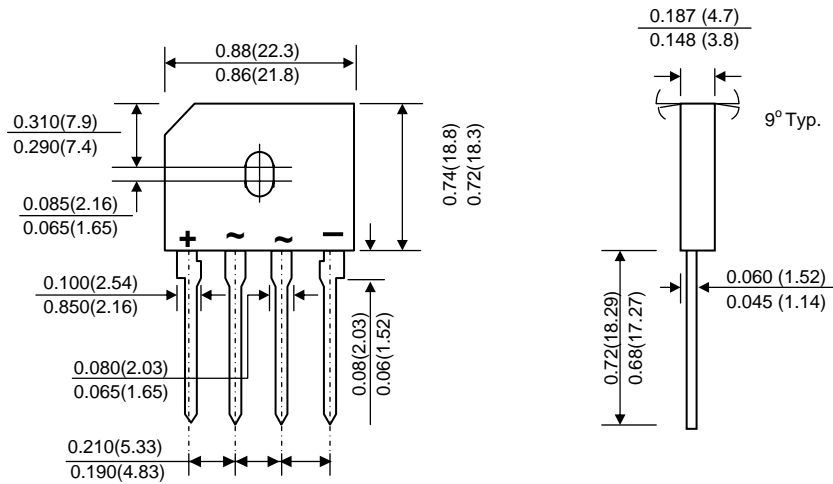

TO-220AC

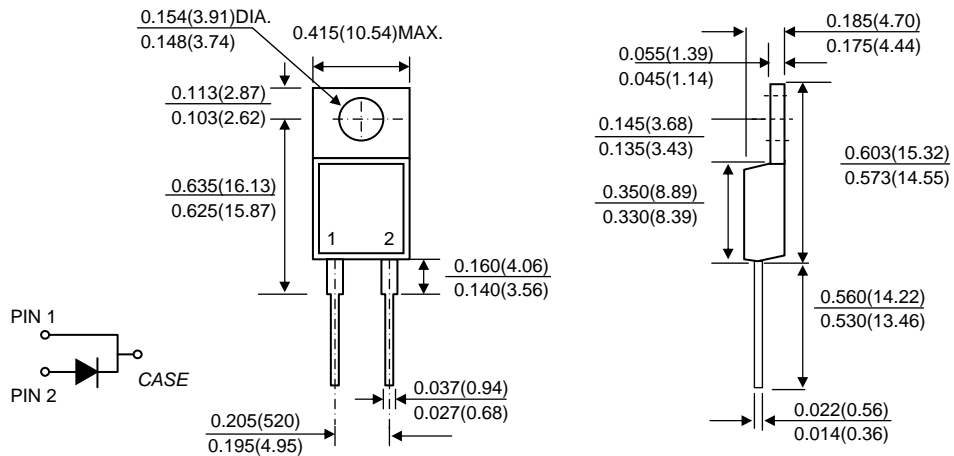

TO-220AB

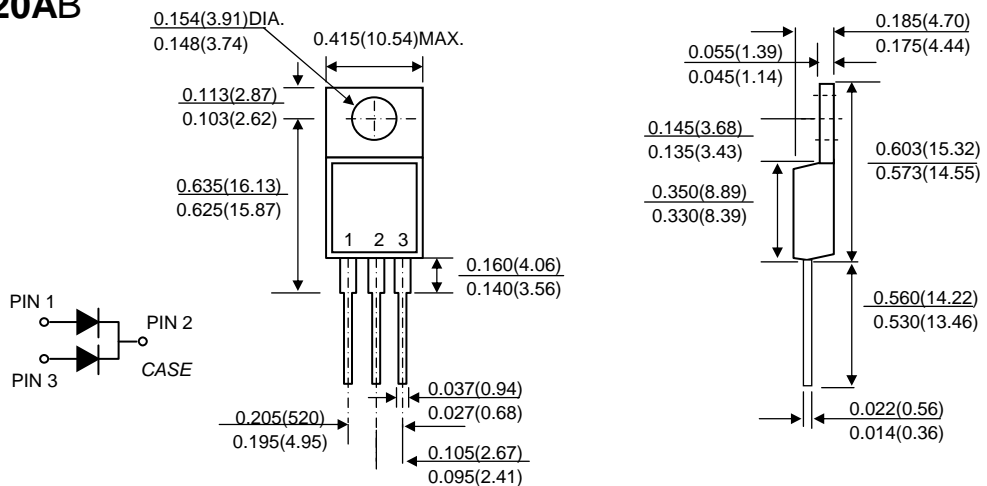

Package Outline

Dimension in inches and (millimeters)

ITO-220AC

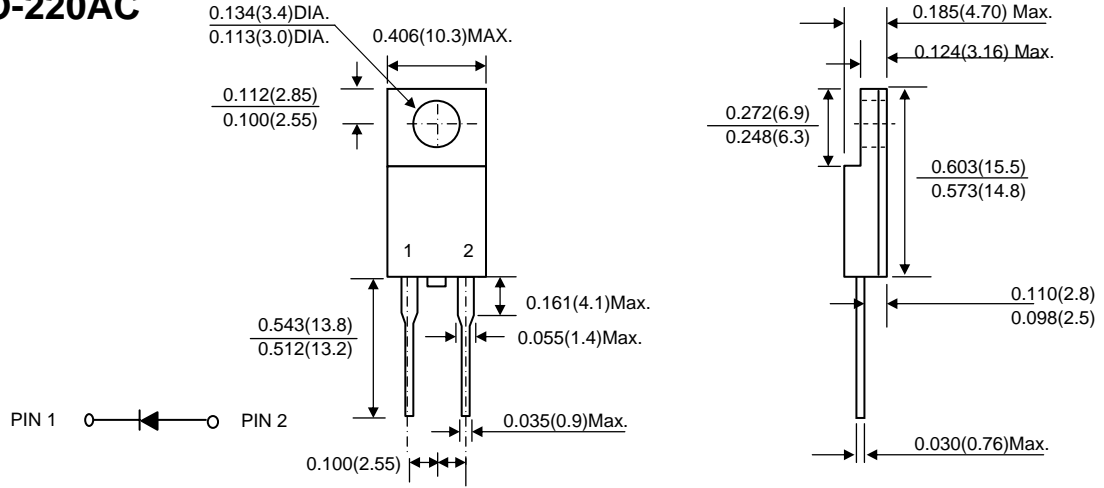

ITO-220AB

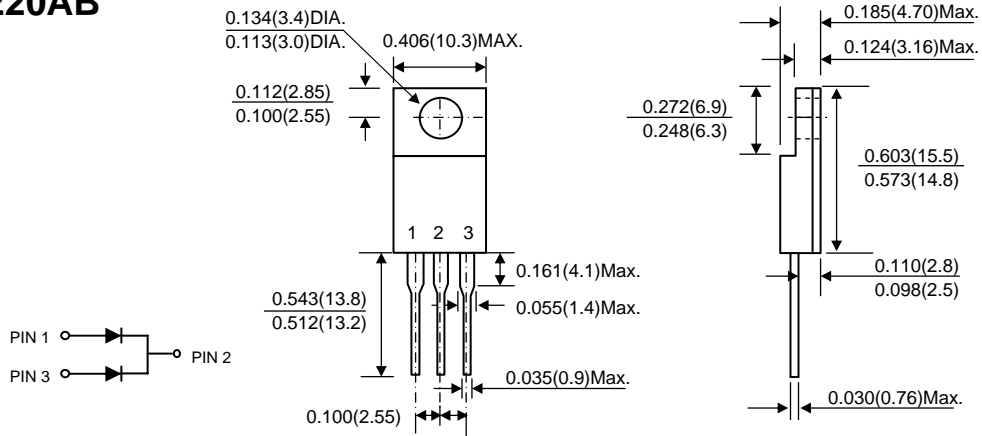

TO-247AD (TO-3P)

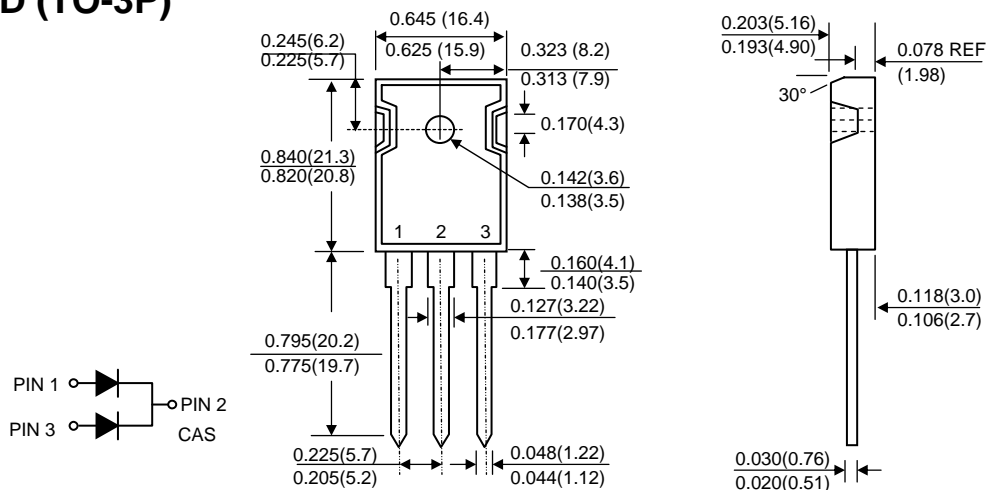

SOD-923

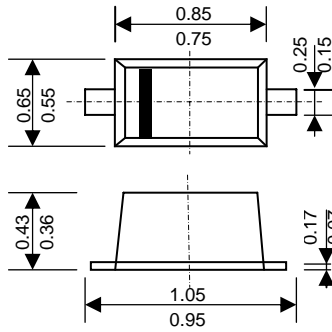

SOT-353

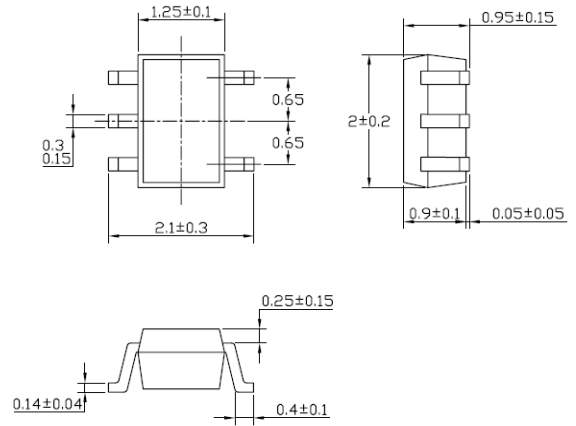

SOT-553

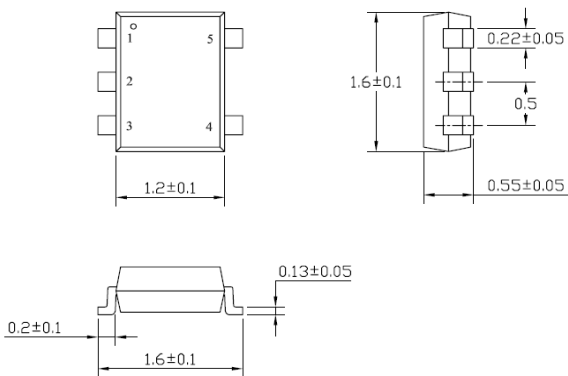

SOT-563

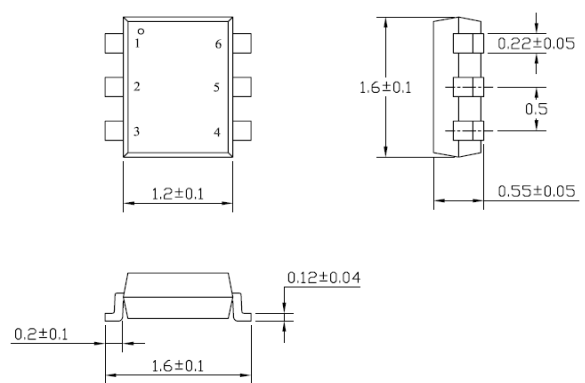

SOP-8

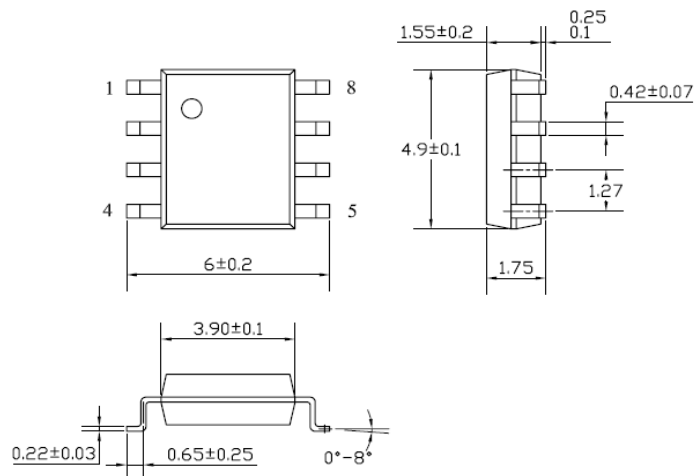



COMPANY HEADQUARTERS

Electronics Industry Public Company Limited

103,117 Moo 4 EPZ 1, Lat Krabang Industrial Estate
Chalongkrung Road, Lat Krabang, Bangkok 10520 Thailand
Tel: (662) 326 1234, 326 1541, 739 4580
Fax : (662) 326 1020, 326 0933
E-mail : eic@eicsemi.com

EIC WORLDWIDE SALES OFFICES

USA

EIC Semiconductor, Inc.

15705 Arrow Highway, # 4 & 5, Irwindale, CA 91706 USA
Tel: (626) 960-0877 Fax: (626) 960-0871
E-mail:sales@eicsemi.com

EUROPE

EIC Semi Ltd

61 Capesthorne Drive Swindon SN25 1UP England, UK
Tel: +44 (0) 1793 703579 Fax: +44 (0) 1793 877148
Email : eurosales@eicsemi.com

ASIA

EIC International Co.,Ltd

Room 702, Block B, Hoi Luen Industrial Centre
55 Hoi Yuen Road, Kwun Tong, Kowloon, Hong Kong
Tel : (852) 2341 6681 Fax: (852) 2343 9959

Sun Light Electronics (H.K) Ltd.

Room 703, Block B, Hoi Luen Industrial Centre,
55 Hoi Yuen Road, Kwun Tong, Kowloon, Hong Kong
Tel : (852) 2389 8280 Fax : (852) 2343 2315
Email : info@sunlight.com.hk <http://www.sunlight.com.hk>

Sun Light, China Headquarter

Sun Light Electronic Building,
Punan Road, Eastern Section of Guangzhou Economic and Technological
Development District,
Guangzhou, China 510760
Tel : (86-20) 82251238
Fax : (86-20) 82251805