

**■ Introduction**

The **EM1308/9** is a CMOS step-up switching DC/DC converter that mainly consists of a reference voltage source, an oscillator, and a comparator. The MC1408 allows the duty ratio to be automatically switched according to the load (light load: 50%, high output current: 75%), enabling products with a low ripple over a wide range, high efficiency, and high output current. With the EM1308/9, a step-up switching DC/DC converter can be configured by using an external coil, capacitor, diode and NMOS or NPN. The built-in MOSFET is turned off by a protection circuit when the voltage at the LX pin exceeds the limit to prevent it from being damaged. This feature, along with the mini package and low current consumption, makes the MC1408 ideal for applications such as the power supply unit of portable equipment.

**■ Applications**

- PDA
- DSC
- LCD Panel
- RF-Tags
- MP3
- Portable Instrument
- Wireless Equipment

**■ Features**

- Low voltage operation: Startup at 0.9 V min. ( $I_{OUT} = 1 \text{ mA}$ ) guaranteed
- Duty ratio: 66/78%, builtin auto switching
- External parts: Coil, capacitor, diode, NMOS
- High efficiency:  $\pm 85\%$  (typ.)
- Output voltage Adjustable
- Providing Flexibility for Using Internal and External Power Switches
- Zero Shutdown Mode Supply Current
- 6 $\mu$ A Quiescent (Switch-off) Supply Current
- Small SOT23-5, SOT89-5 Package & SOT-26(customer order)

## ■ Block Diagrams

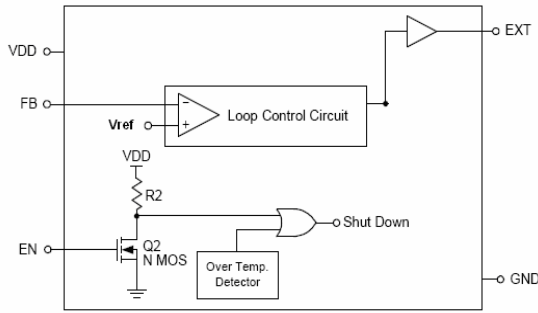

**EM1308**

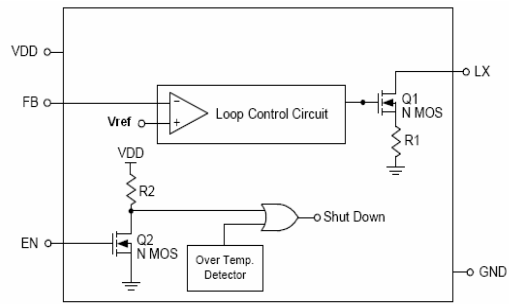

**EM1309**

## ■ Pin Assignment

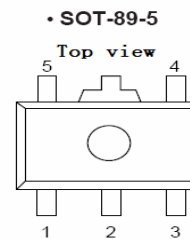
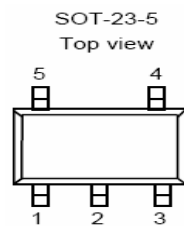

Pin No. ( SOT23-5 )				Pin Name	Functions
EM1308A	EM1308B	EM1309A	EM1309B		
1	1	1	1	FB	Feedback Input Pin
2	2	2	2	V <sub>DD</sub>	IC power supply pin
-	3	-	3	EN	Chip Enable (Active High)
3	-	3	-	NC	No Connection
4	4	4	4	V <sub>SS</sub>	GND pin
5	5	-	-	EXT	External transistor connection pin
-	-	5	5	LX	Pin for Switching

Pin No. ( SOT89-5 )				Pin Name	Functions
EM1308A	EM1308B	EM1309A	EM1309B		
-	1	-	1	EN	Chip Enable (Active High)
1	-	1	-	NC	No Connection
2	2	2	2	V <sub>DD</sub>	IC power supply pin
3	3	3	3	FB	Feedback Input Pin
-	-	4	4	LX	Pin for Switching
4	4	-	-	EXT	External transistor connection pin
5	5	5	5	V <sub>SS</sub>	GND pin

## ■ Absolute Maximum Ratings

(Unless otherwise specified, Ta=25°C)

Parameter		Symbol	Ratings	Unit
V <sub>OUT</sub> pin voltage		V <sub>OUT</sub>	V <sub>SS</sub> -0.3 ~ V <sub>SS</sub> +10	V
EN pin voltage		EN	V <sub>SS</sub> -0.3 ~ V <sub>SS</sub> +10	V
LX pin voltage		V <sub>LX</sub>	V <sub>SS</sub> -0.3 ~ V <sub>SS</sub> +10	V
LX pin current		I <sub>LX</sub>	1000	mA
Power dissipation	SOT-23-5	PD	250	mW
	SOT-23-6		250	mW
	SOT-89-3		500	mW
Operating temperature		Topr	-40 ~ +85	°C
Storage temperature		Tstg	-40 ~ +125	°C

## ■ Electrical Characteristics

(Unless otherwise specified, Ta =25°C)

Parameter	Symbol	Conditions	Min.	Typ.	Max.	Unit
Feedback Voltage	V <sub>FB</sub>	—	3.234	3.3	3.366	V
Input voltage	V <sub>IN</sub>	—	—	—	10	V
Operation start voltage	V <sub>ST</sub>	I <sub>OUT</sub> = 1 mA	—	—	0.9	V
Current consumption 1	I <sub>SS1</sub>	V <sub>CC</sub> =5V, Continuously Switching	—	30	40	μA
Current consumption 2	I <sub>SS2</sub>	V <sub>CC</sub> =5V, FB=3.5V, No Switching	—	5	10	μA
Shut Down Current	I <sub>SSS</sub>	V <sub>CC</sub> =5V, V <sub>EN</sub> =0 V	—	—	0.5	μA
Switching current	I <sub>SW</sub>	V <sub>LX</sub> = 0.4 V	100	200	—	mA
Switching transistor leakage current	I <sub>SWQ</sub>	No external parts, V <sub>LX</sub> =V <sub>OUT</sub> =10 V, V <sub>EN</sub> = 0 V	—	—	0.5	μA
Line regulation	ΔV <sub>OUT1</sub>	V <sub>IN</sub> = 0.4×V <sub>OUT</sub> ~0.6×V <sub>OUT</sub> (V <sub>OUT</sub> =5V)	—	20	50	mV
Load regulation	ΔV <sub>OUT2</sub>	I <sub>OUT</sub> = 10 μA ~ 50mA (V <sub>OUT</sub> =5V)	—	20	50	mV
Oscillation frequency	f <sub>OSC</sub>			100		kHz
Duty ratio 1	Duty1	V <sub>OUT</sub> = 0.95×V <sub>OUT</sub> , measure waveform at LX pin	70	78	85	%
Duty ratio 2	Duty2	Measure waveform at LX pin with light load	—	66	—	%
Efficiency	EFFI			85		%
Shutdown pin input voltage	V <sub>SH</sub>	V <sub>OUT</sub> =0.95×V <sub>OUT</sub> , judge oscillation at LX pin	0.75	—	—	V
	V <sub>SL1</sub>	V <sub>OUT</sub> = 0.95×V <sub>OUT</sub> , judge stop at LX pin	—	—	0.3	V
Shutdown pin input current	I <sub>SH</sub>	V <sub>EN</sub> = 10V	-0.1	—	0.1	μA
	I <sub>SL</sub>	V <sub>EN</sub> =0V	-0.1	—	0.1	μA

Remark: 1、V<sub>IN</sub>=V<sub>OUT(S)</sub> ×0.6 applied, I<sub>OUT</sub>=V<sub>OUT(S)</sub> / 250 Ω

2、Shutdown function built-in type: EN pin is connected to V<sub>OUT</sub>

## ■ Standard Circuits

**Component:** Inductor: 47uH(Sumida)

Diode: IN5817、IN5819

Capacitor: 47uF/16V(Tantalum type)

MOS: XP151、XP161

$R_{FB}$ : Set up so that  $R_{FB1}/R_{FB2} = (V_{OUT} - 3.3) / 3.3$  ( $V_{OUT}$ =set-up output voltage) ,  
Please use with  $R_{FB1} + R_{FB2} \leq 2M \Omega$

$C_{FB}$ : Set up that  $Fzfb = 1 / (2 \times \pi \times C_{FB} \times R_{FB1})$  is within the Adjustments necessary  
in respect of  $L, C_L$ .

### 1. EM1308 Circuits:

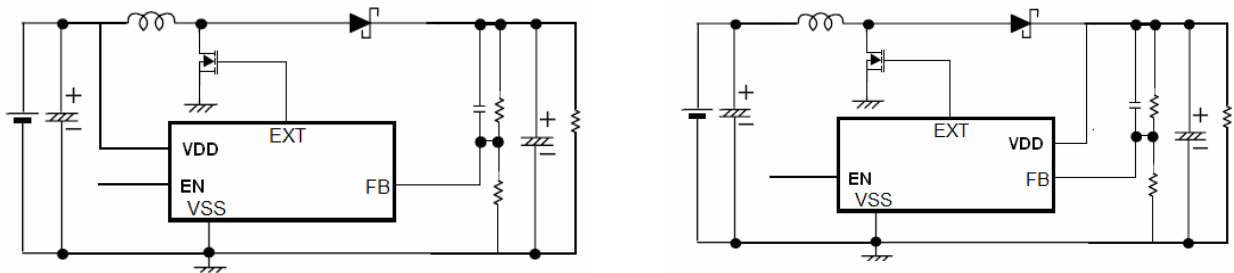

( Note: When  $V_{IN} \leq 2V, V_{DD}$  contact to  $V_{OUT}$ ; When  $V_{IN} \geq 2V, V_{DD}$  contact to  $V_{IN}$ .)

### 2. EM1309 Circuits:

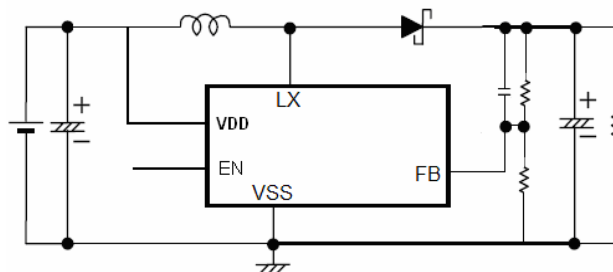

## ■ Characteristics

### a. $V_{OUT}$ VS $I_{OUT}$ : ( $V_{OUT} = 5.5V$ )

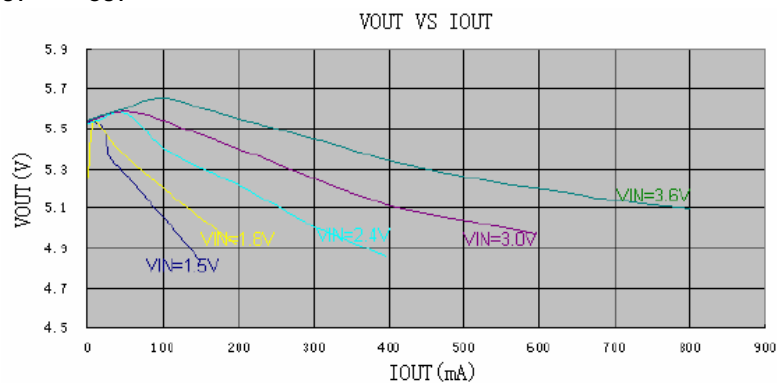

**b. Efficiency VS I<sub>OUT</sub>: (V<sub>OUT</sub>=5.5V)**

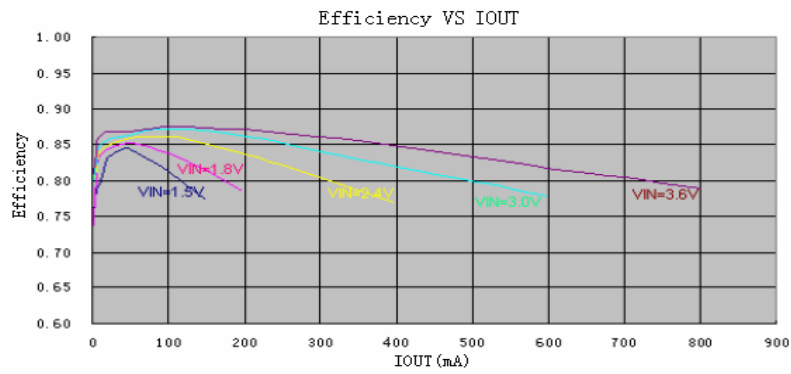

**c. V<sub>OUT</sub> VS I<sub>OUT</sub>: (V<sub>OUT</sub>=12V)**

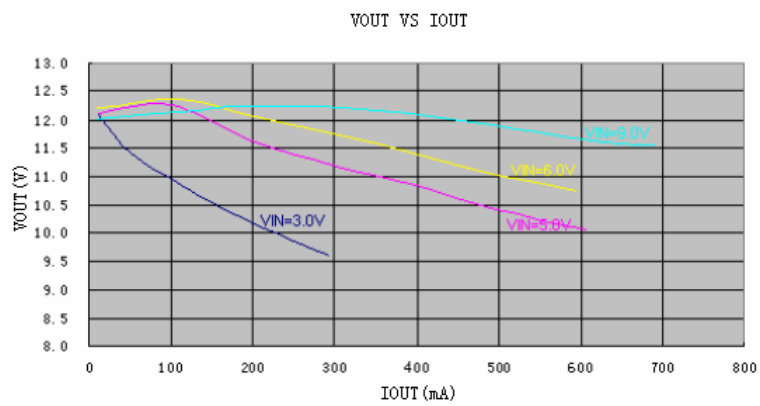

**d. Efficiency VS I<sub>OUT</sub>: (V<sub>OUT</sub>=12V)**

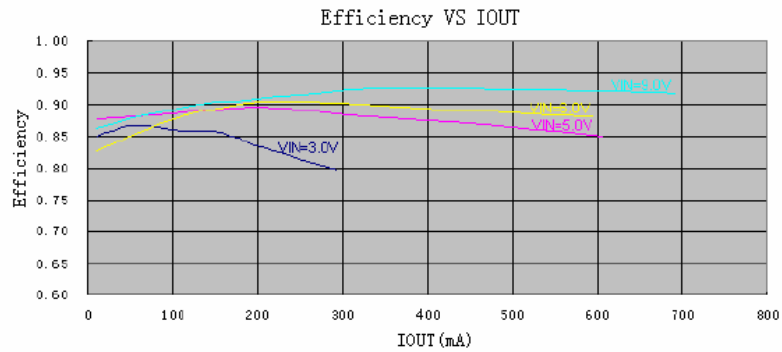

**e. V<sub>OUT</sub> VS I<sub>OUT</sub>: (V<sub>OUT</sub>=18V)**

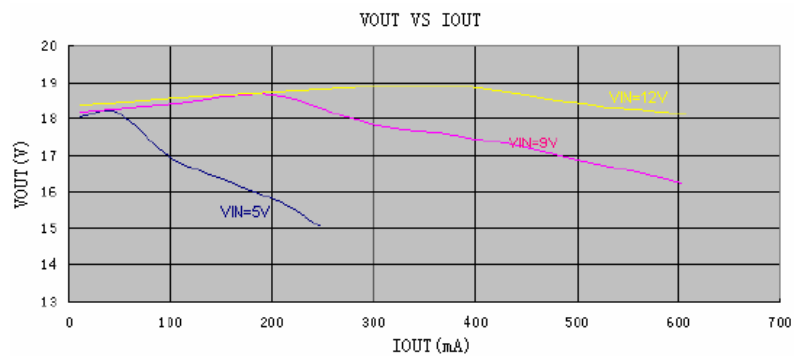

**f. Efficiency VS I<sub>OUT</sub>: (V<sub>OUT</sub>=18V)**

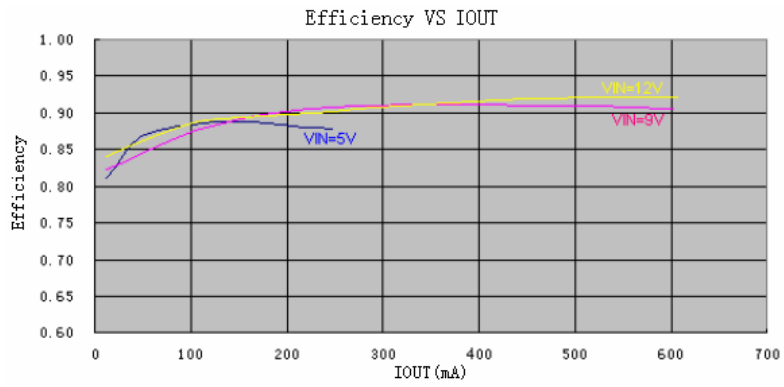

**■ Package information**

**• SOT-23-5**

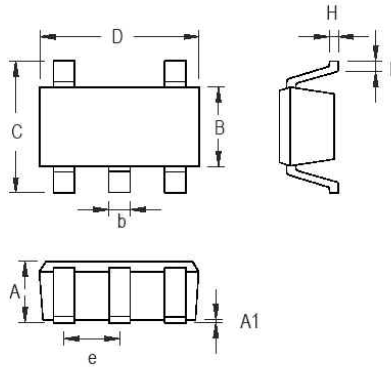

Symbol	Dimensions In Millimeters		Dimensions In Inches	
	Min	Max	Min	Max
A	0.889	1.295	0.035	0.051
A1	0.000	0.152	0.000	0.006
B	1.397	1.803	0.055	0.071
b	0.356	0.559	0.014	0.022
C	2.591	2.997	0.102	0.118
D	2.692	3.099	0.106	0.122
e	0.838	1.041	0.033	0.041
H	0.080	0.254	0.003	0.010
L	0.300	0.610	0.012	0.024

• SOT- 89- 5

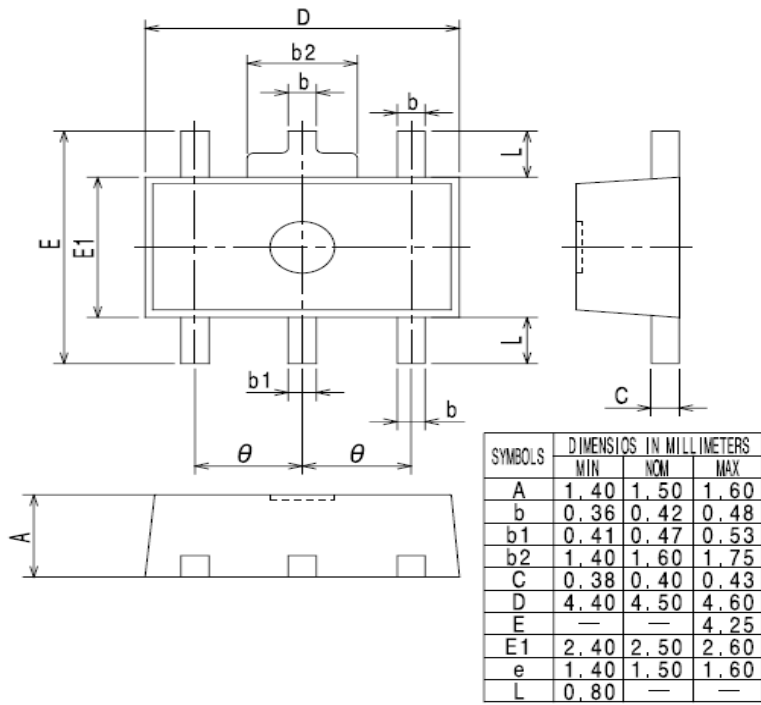

EM1308 应用注意事项:

DC/DC 变换电路 1308 是升压式变换电路，多用于将电源升高到 3.3V 以上。我们希望将输入的电能量尽可能多的转换成输出的能量，这就是转换效率。

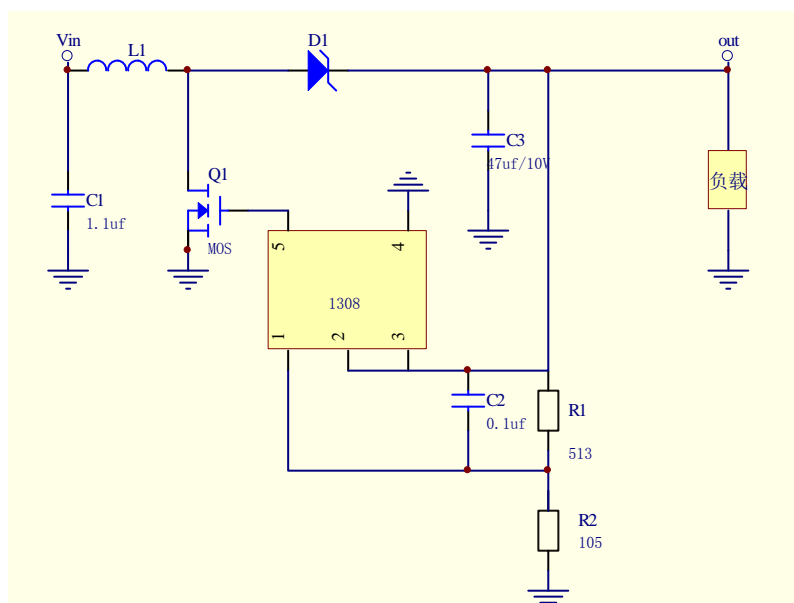

图一 EM1308 的典型应用线路

线路效率与下列因素有关

1. 因为 DC/DC 的工作频率较高，因此 PCB 板的布线不可马虎。布线应该尽可能短而粗，以减小布线的电感和电阻。
2. 外围尽可能不要使用带有引线的元器件，而尽可能使用贴片元器件。
3. 储能电感 L1 的要求：在满足电感量的情况下线径越粗效率越高。
4. 整流二极管应该使用工作频率高（普通整流二极管无法工作）、正向压降低的肖特基二极管。如果工作电流较大，还应该选用大功率的肖特基二极管。
5. C3 滤波电容应该使用等效电感小、等效电阻小的钽电容。
6. Q 1 MOS 开关管导通电阻越小效率越高。
7. 大电流工作时，由于供电电池内阻消耗的功率也要增加。因此供电电池的质量越好，效率也就越高。