

DI-171 Design Idea

LinkSwitch-TN

Low Cost Dimmable LED Ballast Using the Valley Fill Current Shaping Circuit

Application	Device	Power Output	Input Voltage	Output Voltage	Topology
LED Lighting	LNK306PN	9 W	108 – 132 VAC	70 V	Buck-Boost

Design Highlights

- Meets ENERGY STAR SSL requirement (9/12/07) PF>0.9
- High efficiency, better than 85% at full load
- Meets EN55015B EMI requirements
- Dimmable through standard triacs
- Constant current source with overvoltage protection
- Protection features
- Hysteretic over-temperature shutdown
- Auto-restart functionality provides output short circuit protection

Operation

The LinkSwitch-TN supply shown in Figure 1 provides a constant current output of up to 9 W at a maximum output voltage of 70 VDC, ideal for driving LEDs. A passive valley-fill power factor correction (PFC) circuit gives the supply a power factor greater than 0.92, which meets requirements of ENERGY STAR SSL for commercial applications. Care has been taken such that the supply also meets EN55015B EMI requirements.

Line fuse F1 protects the power supply in case of catastrophic failures. Capacitors C6 and C10 provide differential filtering. EMI is mitigated by inductors L1 and L2 along with resistors R15 and R16.

Full wave rectification is accomplished by diodes D5-D8. Diodes D2, D3 and D4, along with capacitors C1 and C2, form the valley fill circuit and provide power factor correction.

The valley-fill circuit shapes the input current in a manner to improve the power factor. Capacitors C1 and C2 are charged in series and discharged in parallel. Due to the presence of diode D2, so long as input AC voltage is above the voltage across C1 and C2 ($V_{AC}/2$), the line current flows to the load. Once the line voltage drops to below $V_{AC_PEAK}/2$, the diodes D3 and D4 become forward biased, allowing C1 and C2 to start discharging in parallel. Thus, input current flows continuously from $30^\circ - 150^\circ$ and $210^\circ - 330^\circ$. This greatly improves the THD and pf of the system.

Resistor R1 helps to smooth the input current spikes and improves the power factor by limiting the current into capacitors C1 and C2. Capacitor C8 helps to improve the EMI.

Inductor L3 is the energy storage element in the buck-boost converter. Diode D1 is an ultrafast recovery type diode that conducts during the off time of the MOSFET in U1 and delivers L3's energy to output capacitor C3. Diodes VR1, VR2 and resistor R14 act to clamp the output voltage under no-load conditions to approximately 80 V.

The LNK306PN device uses an ON/OFF control method. Whenever current in excess of $49 \mu A$ is delivered into the FB pin of U1, MOSFET switching is disabled. Upon the device's next internal clock cycle, the FB pin current is sampled, and if it is below the

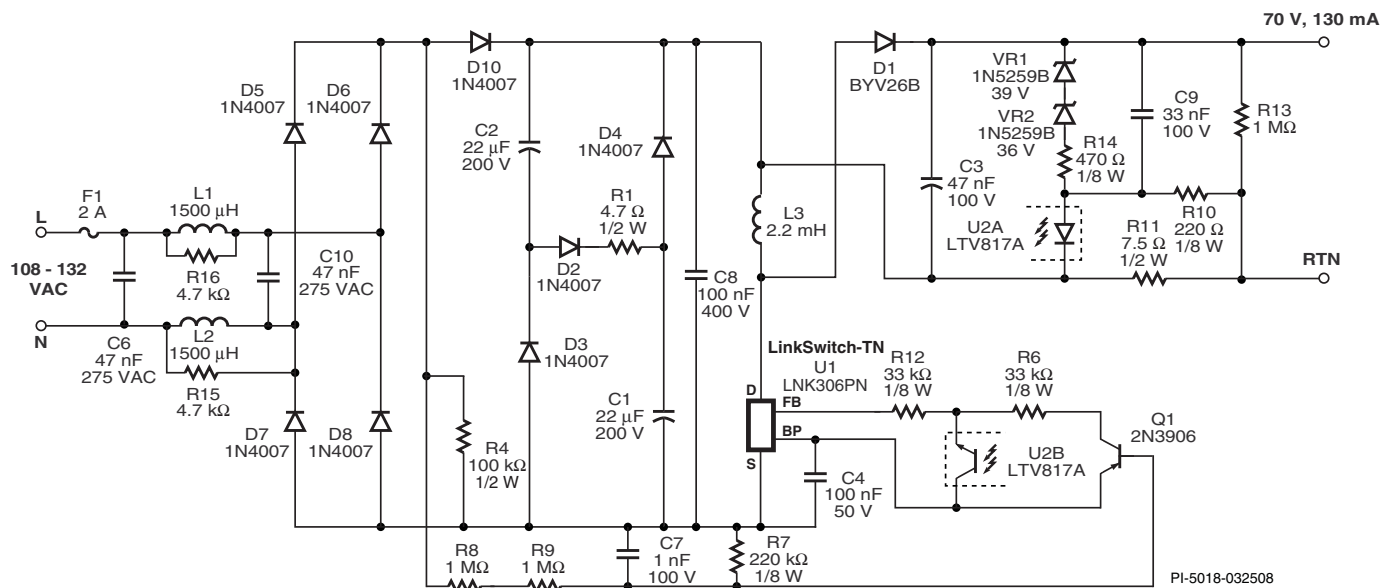

Figure 1. Schematic of a 9 W LED Driver Using a Valley Fill Circuit for Improved Power Factor.

49 μ A threshold, MOSFET switching is enabled again. Regulation of the output is accomplished through enabling and disabling (skipping) switching cycles.

Resistor R11 is a current sense resistor and is chosen to supply 130 mA at 9 W. The voltage across R11 is applied across the diode of optocoupler U2A and gain setting resistor R10. This feedback signal is applied to U1's FB pin through the transistor U2B and resistor R12. Resistor R13 is a bleed resistor for the output that may be eliminated if the output is not user accessible.

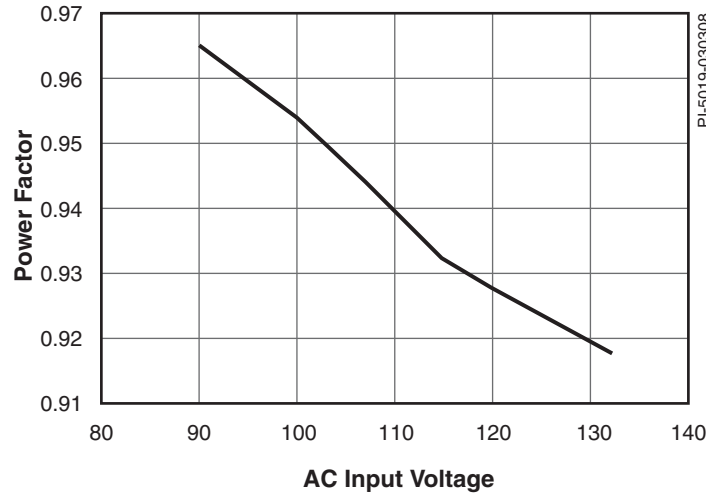

Figure 2. Power Factor (pf) vs AC Input Voltage.

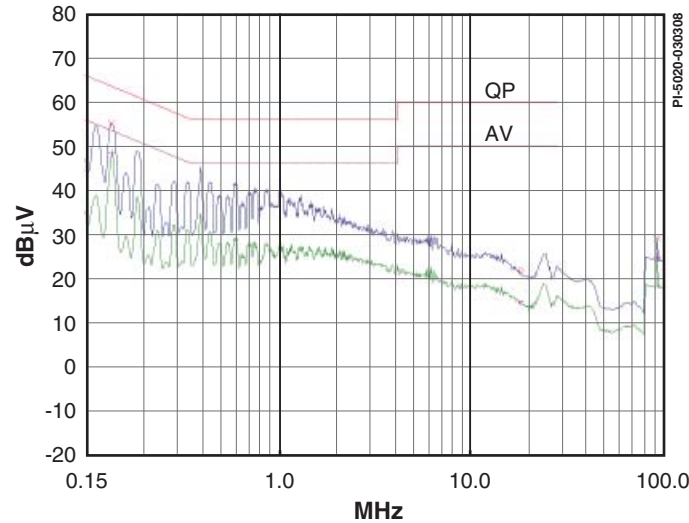

Figure 3. Worst Case EMI Measured at 115 VAC With Output Floating. EN55015B Limit Lines Also Shown.

The feedback scheme utilized also allows for dimming from a standard phase control dimmer unit. Diode D10 isolates the line voltage from the bulk capacitors which allows for conduction angle information to be obtained. Resistors R7, R8 and R9 form a voltage divider network. The voltage across R7 is averaged by capacitor C7. As the line voltage is reduced with a dimmer, the voltage across capacitor C7 reduces, thereby reducing the voltage on the base of Q1. Once Q1's base falls below 5.1 V, Q1 turns on, pushes current into the FB pin, inhibits switching thereby reducing the average load current and accomplishing dimming. Resistor R4 loads the AC sensing node to allow for fast turn-on and turn-off times of Q1. Through this method, the line voltage feedback network described can accomplish dimming of the output LEDs.

Key Design Points

- Capacitor C8 should not be too large in order to avoid degradation of p.f.
- Select diode D1 with voltage rating greater than the maximum DC bus voltage (allow 25% derating).
- Resistor R13 is the bleeder resistor to discharge C3 during power down.
- The values of C1 and C2 should be equal.

Inductor Parameters

Core Material	TDK PC40EE19-Z or equivalent, gapped for ALG of 105 nH/t ²
Bobbin	EE19 Vertical, 10-pin Yih-Hwa YW-047 or equivalent
Winding Details	Winding-1: 180 turns, 29 AWG magnet wire
Primary Inductance	2.2 mH, \pm 12%

Table 1. Inductor Parameters. (AWG = American Wire Gauge)

Power Integrations
5245 Hellyer Avenue
San Jose, CA 95138, USA.
Main: +1 408-414-9200
Customer Service
Phone: +1-408-414-9665
Fax: +1-408-414-9765
Email: usasales@powerint.com

On the Web
www.powerint.com

Power Integrations reserves the right to make changes to its products at any time to improve reliability or manufacturability. Power Integrations does not assume any liability arising from the use of any device or circuit described herein. POWER INTEGRATIONS MAKES NO WARRANTY HEREIN AND SPECIFICALLY DISCLAIMS ALL WARRANTIES INCLUDING, WITHOUT LIMITATION, THE IMPLIED WARRANTIES OF MERCHANTABILITY, FITNESS FOR A PARTICULAR PURPOSE, AND NON-INFRINGEMENT OF THIRD PARTY RIGHTS. The products and applications illustrated herein (transformer construction and circuits external to the products) may be covered by one or more U.S. and foreign patents or potentially by pending U.S. and foreign patent applications assigned to Power Integrations. A complete list of Power Integrations' patents may be found at www.powerint.com. Power Integrations grants its customers a license under certain patent rights as set forth at <http://www.powerint.com/ip.htm>.

The PI logo, TOPSwitch, TinySwitch, LinkSwitch, DPA-Switch, PeakSwitch, EcoSmart, Clampless, E-Shield, Filterfuse, StackFET, PI Expert and PI FACTS are trademarks of Power Integrations, Inc. Other trademarks are property of their respective companies. ©2008, Power Integrations, Inc.