

A8435

High Efficiency Charge Pump White LED Driver

Package ES:

MLP 3 × 3 mm

0.75 mm Nominal Height



Approximate Scale 1:1

The A8435 high efficiency charge pump IC offers a simple, low-cost white LED driver solution for portable electronics display applications. Using a proprietary control scheme (1×, 1.5×), the A8435 can output well-matched currents for up to 4 LEDs, while maintaining the highest efficiency over most of the Li-ion battery lifetime.

The A8435 accepts an input range of 2.7 to 5.5 V and delivers up to 30 mA for each of the four regulated current sources. The A8435 can deliver a total continuous output current of 120 mA, meeting the requirements of most Li-ion battery-powered white LED backlight applications. Outputs can also be tied together for WLED flash/torch applications.

The A8435 offers flexible options for LED current driving. The LED current can be set by any of the following methods: (a) choosing an appropriate value for RSET, (b) 2-bit parallel control with 3 levels, (c) PWM control, or (d) serial programming

The A8435 is available in a very thin profile 0.75 mm (nominal height) 3 × 3 mm MLP-16 package (ES), fitting the needs of space-conscious applications.

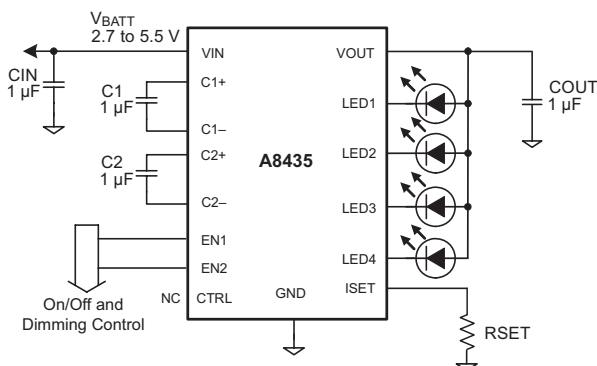

Figure 1. Typical Circuit. Dual wire control configuration: 2-bit parallel or PWM dimming.

FEATURES

- Proprietary adaptive control scheme (1×, 1.5×)
- Maximum efficiency, over 92%
- 0.5% LED current matching
- 1 MHz operating frequency
- Flexible dimming control:
 - Serial 11-level dimming, down to 5%
 - PWM
 - 2-bit parallel
- Drives up to 4 white LEDs
- 30 mA per LED
- 120 mA total continuous output
- Low input ripple and EMI
- Soft-start limits inrush current
- Short circuit protection
- Overvoltage protection
- Thermal shutdown protection
- Space-saving MLP-16 package: 3 × 3 mm footprint
- Very thin 0.75 mm nominal height package

APPLICATIONS

- White LED backlights for cellular phones, PDAs
- Digital cameras, camcorders
- Portable audio devices
- Other portable device white LED backlighting
- 120 mA WLED flash/torch

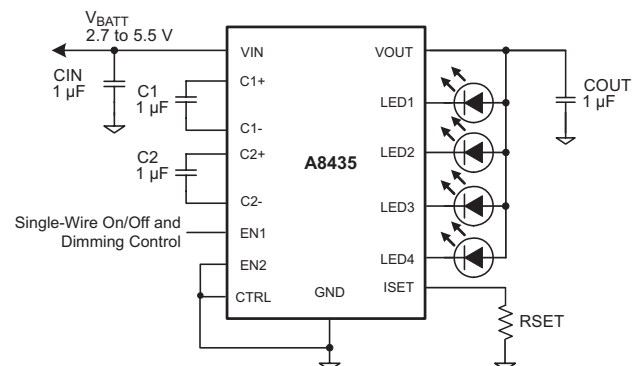
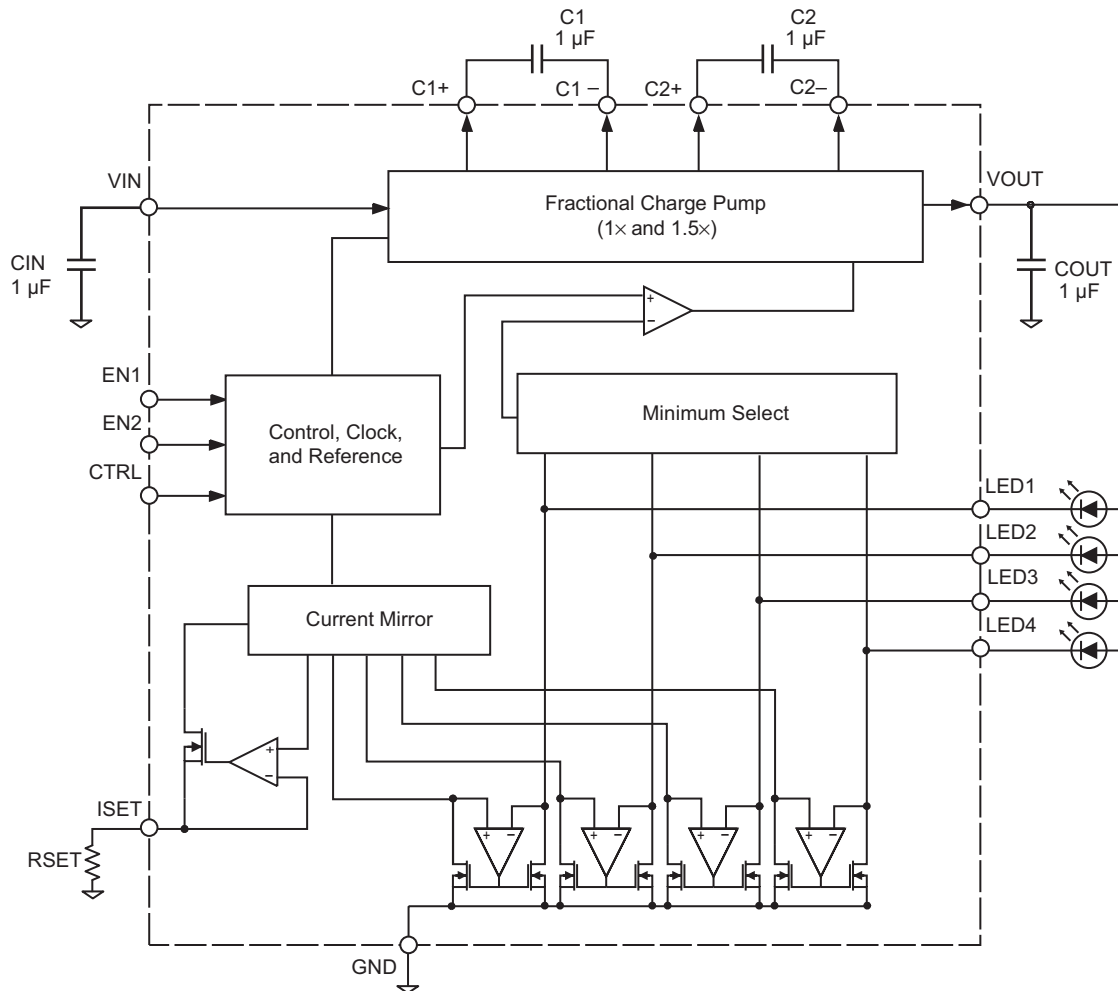

Figure 2. Typical Circuit. Single wire control configuration.

A8435 High Efficiency Charge Pump White LED Driver

Functional Block Diagram



Absolute Maximum Ratings

Input or Output Voltage	
VIN, VOUT, C1+, C1-, C2+, and C2- pins.....	-0.3 to 6 V
All other pins.....	-0.3 to VIN + 0.3 V
VOUT Short Circuit to GND	Continuous
Operating Ambient Temperature, TA	-40°C to 85°C
Maximum Junction Temperature, TJ(max)	150°C
Storage Temperature, TS	-55°C to 150°C

Package Thermal Characteristics

$R_{\theta JA} = 68 \text{ }^\circ\text{C/W}$, on a 4-layer board
(vendor data; unverified)
Additional information is available on the Allegro Web site.

Package is lead (Pb) free, with 100% matte tin leadframe plating.

Use the following complete part number when ordering:

Part Number	Packaging*	Package Type
A8435EESTR-T	7-in. reel, 1500 pieces/reel	ES, 3 × 3 mm MLP-16

*Contact Allegro for additional packing options.

A8435 High Efficiency Charge Pump White LED Driver

Pin-out Diagram

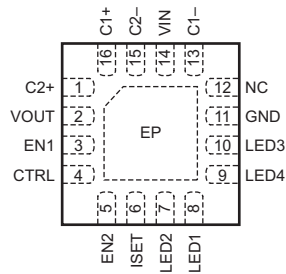

(Top View)

Terminal List Table

Name	Pin Number	Function*
C1-	13	Negative terminal of capacitor C1.
C1+	16	Positive terminal of capacitor C1.
C2-	15	Negative terminal of capacitor C2.
C2+	1	Positive terminal of capacitor C2.
CTRL	4	Brightness control scheme toggle. For 2-bit parallel or PWM dimming, leave open or tie to VIN (see table 1). For single-wire serial input dimming, connect to GND (see figure 2).
EN1	3	When CTRL is open or HIGH: Enable and dimming control input 1 (see table 1). When CTRL is grounded: single-wire enable and dimming control (see table 1 and figure 2). (Do not leave unconnected.)
EN2	5	When CTRL is open or HIGH: Enable and dimming control input 2 (see table 1). When CTRL is grounded: this pin disables shutdown. (Do not leave unconnected.)
EP	-	Exposed metal pad on bottom side. Connect this to ground plane for better thermal performance.
GND	11	Ground.
ISET	6	Connect RSET resistor to ground to set desired constant current through LEDs.
LED1	8	Current sink for LED1. Connect to VIN or VOUT if not used for LED. (Do not leave unconnected.)
LED2	7	Current sink for LED2. Connect to VIN or VOUT if not used for LED. (Do not leave unconnected.)
LED3	10	Current sink for LED3. Always connect this pin to LED.
LED4	9	Current sink for LED4. Connect to VIN or VOUT if not used for LED. (Do not leave unconnected.)
NC	12	No Connection.
VIN	14	Power supply voltage input.
VOUT	2	Charge pump voltage source output for connection to the LED anodes.

* See Application Information section for cited figure and tables.

A8435 High Efficiency Charge Pump White LED Driver

ELECTRICAL CHARACTERISTICS¹

$V_{IN} = V_{EN1} = V_{EN2} = 3.6\text{ V}$, $C_1 = C_2 = 1\ \mu\text{F}$, $T_A = -40\text{ to }85^\circ\text{C}$, typical values at $T_A = 25^\circ\text{C}$ (unless otherwise noted)

Characteristics	Symbol	Test Conditions	Min.	Typ.	Max.	Units	
Input Voltage Range	V_{IN}		2.7	–	5.5	V	
Undervoltage Lockout Threshold	V_{UVLO}	V_{IN} falling, $V_{UVLOHYS} = 35\text{ mV}$	2.25	2.45	2.60	V	
UVLO Hysteresis Window	$V_{UVLOHYS}$		–	35	–	mV	
Quiescent Current	I_Q	Switching, $T_A = 25^\circ\text{C}$	–	2.8	4	mA	
		$EN1 = EN2 = \text{GND}$, $T_A = 25^\circ\text{C}$	–	0.1	1	μA	
Soft-Start Completion Time	t_{SS}		–	2	–	ms	
ISET Bias Voltage	$V_{ISETBIAS}$		0.56	0.6	0.64	V	
ISET Leakage in Shutdown	$V_{ISETLKG}$		–	0.01	1	μA	
ISET Current Range	I_{ISET}		40	–	140	μA	
ISET to LEDx Current Ratio	I_{LEDx}/I_{ISET}	$I_{ISET} = 60\ \mu\text{A}$, CTRL = open or HIGH	$EN1 = EN2 = V_{IN}$	190	219	245	A/A
			$EN1 = V_{IN}$, $EN2 = \text{GND}$	105	121	137	A/A
			$EN1 = \text{GND}$, $EN2 = V_{IN}$	51	60	69	A/A
		$I_{ISET} = 60\ \mu\text{A}$, CTRL = LOW	Full brightness	–	200	–	A/A
I_{LED} Accuracy	E_{ILED}	$EN1 = EN2 = V_{IN}$, $R_{SET} = 4.3\ \text{k}\Omega$	–	± 0.9	–	%	
LED Current Matching ²	ΔI_{LED}	$V_{IN} = 3.6\text{ V}$, $I_{LED} = 30\text{ mA}$ per LED	–	± 0.5	–	%	
Regulation Voltage at LEDx (1.5x)	V_{LED}	$EN1 = EN2 = V_{IN}$	–	150	–	mV	
Open Loop Output Resistance ³	R_{OUT}	1x mode: $[(V_{IN} - V_{OUT})/I_{OUT}]$	–	1.1	1.5	Ω	
		1.5x mode: $[(1.5 \times V_{IN} - V_{OUT})/I_{OUT}]$	–	3.6	10	Ω	
1x to 1.5x Mode Transition Voltage at LEDx	V_{Trans}	V_{LEDx} Falling	–	100	–	mV	
Transition to Dropout Voltage Difference ⁴	ΔV_{dr}	Measured as $V_{Trans} - V_{Dropout}$	–	60	–	mV	
LED Leakage in Shutdown	V_{LEDLKG}	$EN1 = EN2 = \text{GND}$, $V_{IN} = 5.5\text{ V}$, $T_A = 25^\circ\text{C}$	–	0.01	1	μA	
Oscillator Frequency	f_{osc}		–	1	–	MHz	
Output Overvoltage Protection ⁵	V_{OVP}	Open circuit at any LED that is programmed to be in the ON state	–	5.74	–	V	
CTRL, EN1, EN2 Input High Logic Threshold ⁶	V_{IH}		1.6	–	–	V	
CTRL, EN1, EN2 Input Low Logic Threshold ⁶	V_{IL}		–	–	0.4	V	
Input High Current	I_{IH}	$V_{IH} = V_{IN}$	–	–	1	μA	
Input Low Current	I_{IL}	$V_{IL} = \text{GND}$	–	–	1	μA	
EN1 Pulse Low Time ⁷	t_{LO}		0.5	–	500	μs	
EN1 Pulse High Time ⁷	t_{HI}		0.5	–	–	μs	
Initial EN1 Pulse High Time ⁷	$t_{HI}(\text{Init})$	First EN1 pulse after shutdown	100	–	–	μs	
Shutdown Delay ⁷	t_{SHDN}	Falling edge of EN1 pulse	–	2	3	ms	
Thermal-Shutdown Threshold	T_{SHDN}	20°C hysteresis	–	165	–	$^\circ\text{C}$	

¹Specifications guaranteed by design over operating temperature range, -40°C to 85°C .

²LED current matching is defined as $(I_{LEDx} - I_{LED(AVG)})/I_{LED(AVG)}$.

³The open loop output resistance for 1.5x mode is measured with one of the LEDx pins tied to ground or open (thus its voltage is always less than 80 mV).

⁴Dropout Voltage, $V_{Dropout}$, is defined as the LEDx-to-GND voltage at which I_{LEDx} drops 10% below the value of I_{LEDx} at $V_{LEDx} = 200\text{ mV}$.

⁵Guaranteed by design.

⁶EN2 is not used when CTRL is tied to ground.

⁷Applies only when CTRL is tied to ground. See figure 3 in Application Information section.

A8435 High Efficiency Charge Pump White LED Driver

Performance Characteristics

Tests performed using application circuit shown in figure 1: dual wire control; and $V_{IN}=3.6\text{ V}$, $EN1 = EN2 = V_{IN}$, $C_{IN}=C_1=C_2=C_{OUT}=1\ \mu\text{F}$, $R_{SET}=7.5\ \text{k}\Omega$, $T_A=25^\circ\text{C}$ (unless otherwise noted)

Efficiency versus Supply Voltage
Over Range of Dimming Levels, V_{IN} Falling

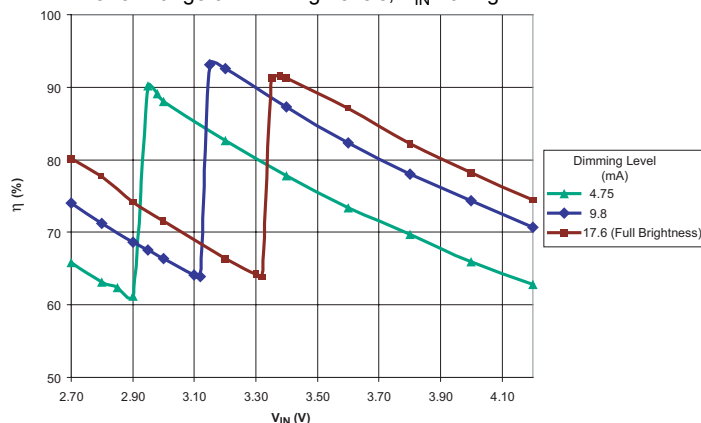

Supply Current versus Supply Voltage
Over Range of Dimming Levels (mA)

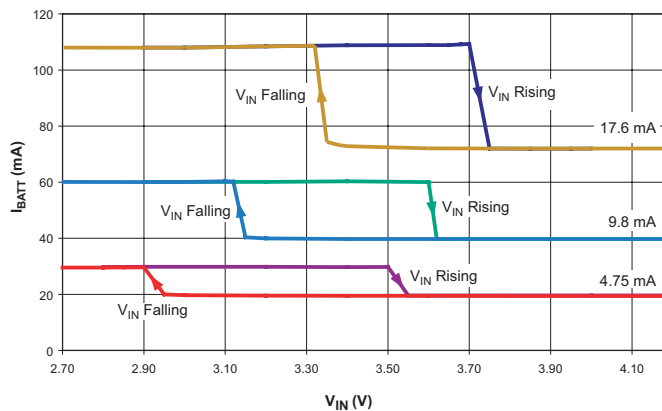

LED Current versus Supply Voltage
Matching Between LEDs <1% Over Range of V_{IN}

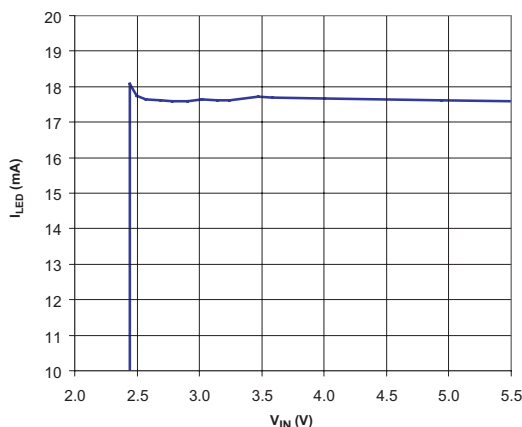

A8435 High Efficiency Charge Pump White LED Driver

Startup Response

Symbol	Parameter	Units/Division
C1	V_{EN}	5 V
C2	I_{BATT}	50 mA
C3	V_{OUT}	2 V
t	time	500 μ s

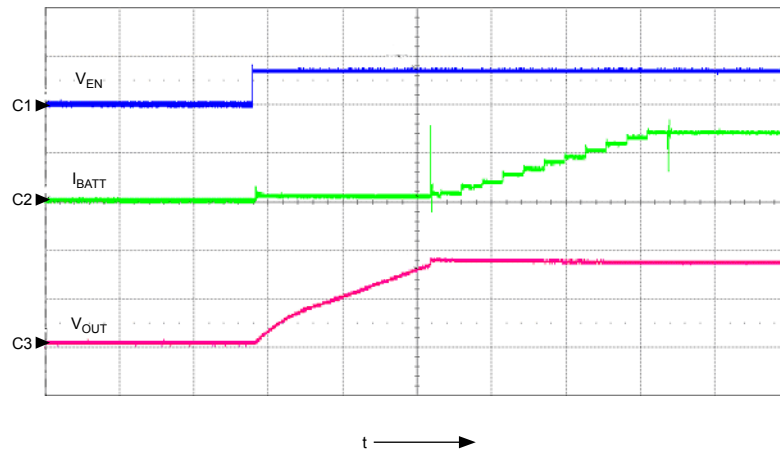

2-Bit (EN1-EN2) Dimming Response

Symbol	Parameter	Units/Division
C1	V_{EN1}	2 V
C2	I_{OUT}	50 mA
t	time	5 μ s

Conditions
EN2 = VIN

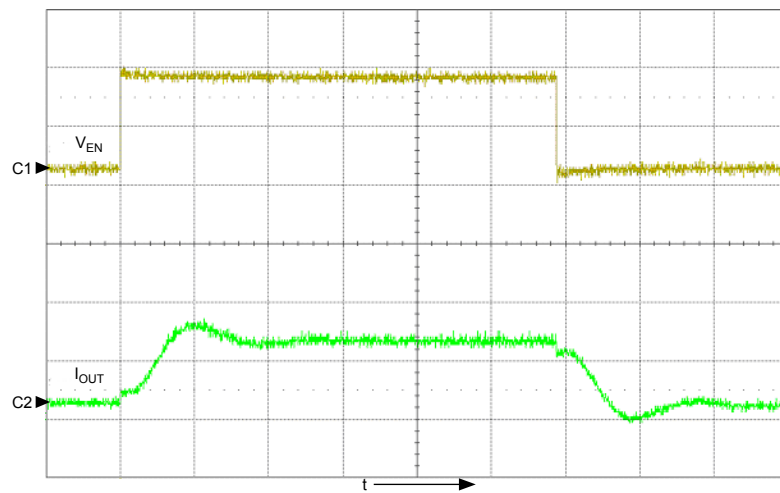

11-Level Single-Wire Serial Dimming Response

Symbol	Parameter	Units/Division
C1	V_{EN1}	2 V
C2	I_{OUT}	50 mA
C3	V_{OUT}	2 V
t	time	10 ms

Conditions
EN2 = CTRL = GND, apply control signal to EN1

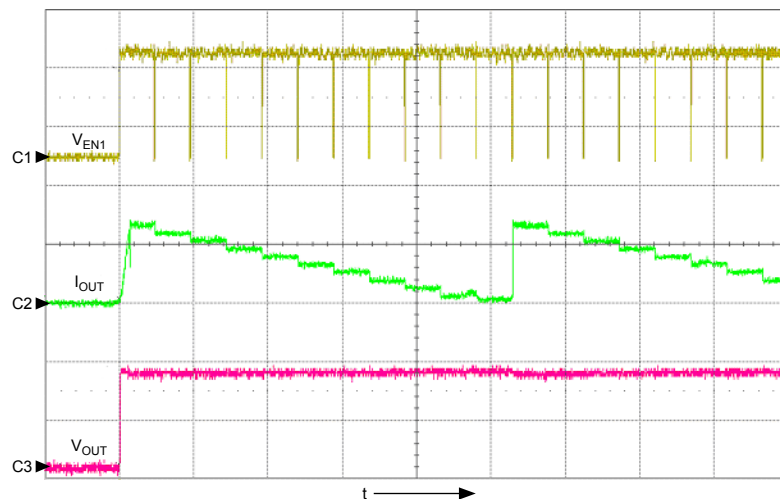

A8435 High Efficiency Charge Pump White LED Driver

Application Information

Setting LED Current

The LED current level, I_{LEDX} , is set by the value chosen for the external resistor, RSET, which is connected to the ISET terminal.

The full current (100%) level for I_{LEDX} can be calculated using the following formulas:

Setting	Formula
CTRL = Open or HIGH	$R_{SET} (\Omega) = 0.6 V \times 219 / I_{LEDX}$
CTRL = LOW	$R_{SET} (\Omega) = 0.6 V \times 200 / I_{LEDX}$

Dimming

The A8435 offers serial, 2-bit parallel, and PWM dimming control. When the CTRL pin is pulled LOW, the EN1 pin accepts one-wire serial pulse input both to enable the part, and to select one of the 11 dimming levels, from 100% down to 5% (see table 1).

With EN2 low, when EN1 is pulled high, the IC turns on. The initial LED current defaults to 100% after softstart is complete. The t_{LO} must be < 500 ms to avoid shutdown. With EN2 high, the operation of EN1 is the same as when EN2 is low, except shutdown is disabled ($T_{LO} = \infty$).

Table 1. CTRL, EN1, and EN2 Pin States

CTRL	EN1	EN2	Brightness	LED Current, I_{LED}
Open or HIGH	LOW	LOW	Shutdown	0
Open or HIGH	LOW	HIGH	27% Brightness	$60 \times I_{ISET}$
Open or HIGH	HIGH	LOW	55% Brightness	$121 \times I_{ISET}$
Open or HIGH	HIGH	HIGH	Full Brightness	$219 \times I_{ISET}$
LOW	Pulse input	No effect	Adjustable; 11 levels of dimming from 100% to 5% (see figure 3; 100% corresponds to $200 \times I_{ISET}$)	
LOW	LOW > 2 ms	LOW	Shutdown	

A8435 High Efficiency Charge Pump White LED Driver

When changing from one specific brightness level to another, the user may not want to keep the existing brightness level stored in memory. A simpler method is to program a shutdown and re-enable, followed by an appropriate number of pulses (from 100%) to reach the target brightness level. The total “LED off” time during shutdown, re-enable, and brightness programming can be kept sufficiently short such that no delay is discernable to the eye.

Shutdown

If the CTRL pin is unconnected or HIGH, the device enters the shutdown mode when EN1 and EN2 are pulled LOW. When configured to have a serial pulse dimming control (the CTRL pin is grounded), the EN1 and the EN2 pins must be pulled LOW for longer than t_{SHDN} (2 ms typical) in order to enter shutdown mode.

The output is high impedance after shutdown.

Disabling Unused LEDs

If any WLED is not used, connect the corresponding pin to either VIN or VOUT to disable it. Never leave open any unused WLED pin. LED pins will sink 30 μ A typical when connected to VIN or VOUT and the IC is enabled.

LED3 must always be selected. For example, to drive 2 LEDs, select LED3 and one of either LED1, LED2, or LED4.

Component Selection

Ceramic capacitors with X5R or X7R dielectric are recommended for the input capacitor, CIN, the output capacitor, COUT, and the charge pump capacitors, C1 and C2.

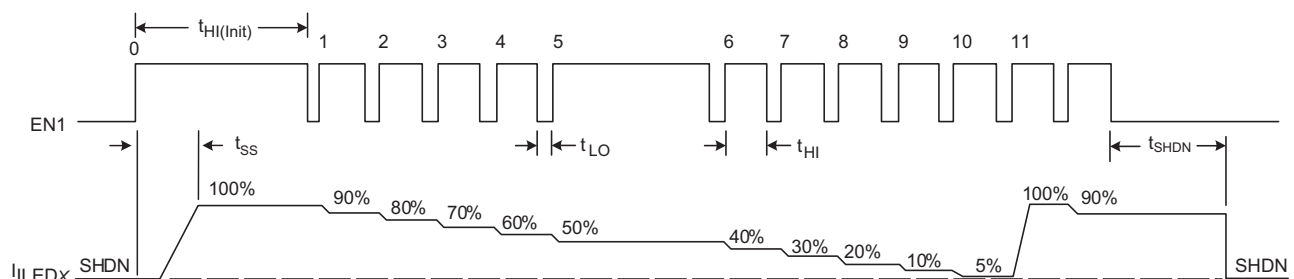





Figure 3. Single-Wire Serial Dimming Control, at pin EN1; CTRL = LOW, EN2 = LOW.

A8435 High Efficiency Charge Pump White LED Driver

Package ES, 3 × 3 mm 16-Pin MLP

Preliminary dimensions, for reference only
 (reference JEDEC MO-220WEED-4, lead length may vary)
 Dimensions in millimeters
 U.S. Customary dimensions (in.) in brackets, for reference only
 Dimensions exclusive of mold flash, gate burrs, and dambar protrusions
 Exact case and lead configuration at supplier discretion within limits shown

-  Terminal #1 mark area
-  Exposed thermal pad (reference only, terminal #1 identifier appearance at supplier discretion)
-  Reference land pattern layout (reference IPC7351 QFN50P300X300-17W4M); adjust as necessary to meet application process requirements and PCB layout tolerances; when mounting on a multilayer PCB, thermal vias at the exposed thermal pad land can improve thermal dissipation (reference EIA/JEDEC Standard JESD51-5)

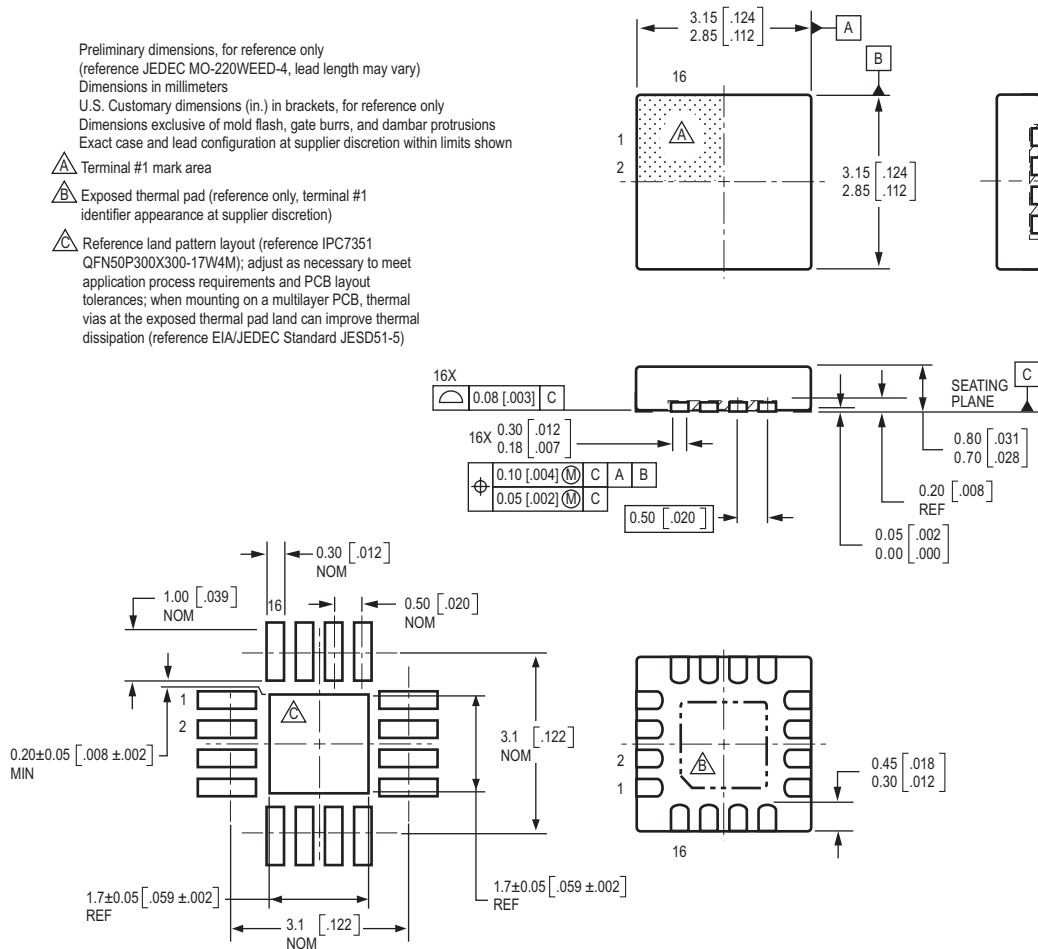

The products described here are manufactured under one or more U.S. patents or U.S. patents pending.

Allegro MicroSystems, Inc. reserves the right to make, from time to time, such departures from the detailed specifications as may be required to permit improvements in the performance, reliability, or manufacturability of its products. Before placing an order, the user is cautioned to verify that the information being relied upon is current.

Allegro products are not authorized for use as critical components in life-support devices or systems without express written approval.

The information included herein is believed to be accurate and reliable. However, Allegro MicroSystems, Inc. assumes no responsibility for its use; nor for any infringement of patents or other rights of third parties which may result from its use.

Copyright©2005, 2006 AllegroMicroSystems, Inc.