

Off-line High Brightness LED Driver

FEATURES

- Open Loop Peak Current Controller
- >90% Efficiency
- Internal 15V to 500V HV Linear Regulator
- Applications from a few mA to more than 1A Output
- LED String from one to Hundreds of Diodes
- PWM & Linear Dimming Capability

DESCRIPTION

The FT871x is an open loop Constant-frequency Peak Current Mode control LED driver control IC. It allows efficient operation of High Brightness (HB) LEDs from voltage sources ranging from 15VDC up to 500VDC. The FT871x controls an external MOSFET at fixed switching frequency. The LED string is driven at constant current rather than constant voltage, thus providing constant light output and enhanced reliability. The output current can be programmed by external resistor or duty cycle PWM waveform from a few milliamps all the way up to 350mA.

The FT871x is ideally suited for buck LED drivers. Since the FT871x operates in open loop current mode control, the controller achieves good output current regulation without the need for loop compensation. The brightness can be up to V_{csmax} (240mV typical).

TYPICAL APPLICATIONS

- DC/DC or AC/DC LED Driver Applications
- RGB Backlighting LED Driver
- Back Lighting of Flat Panel Displays
- General Purpose Constant Current Source
- Signage and Decorative LED Lighting
- Automotive

TYPICAL APPLICATION CIRCUIT

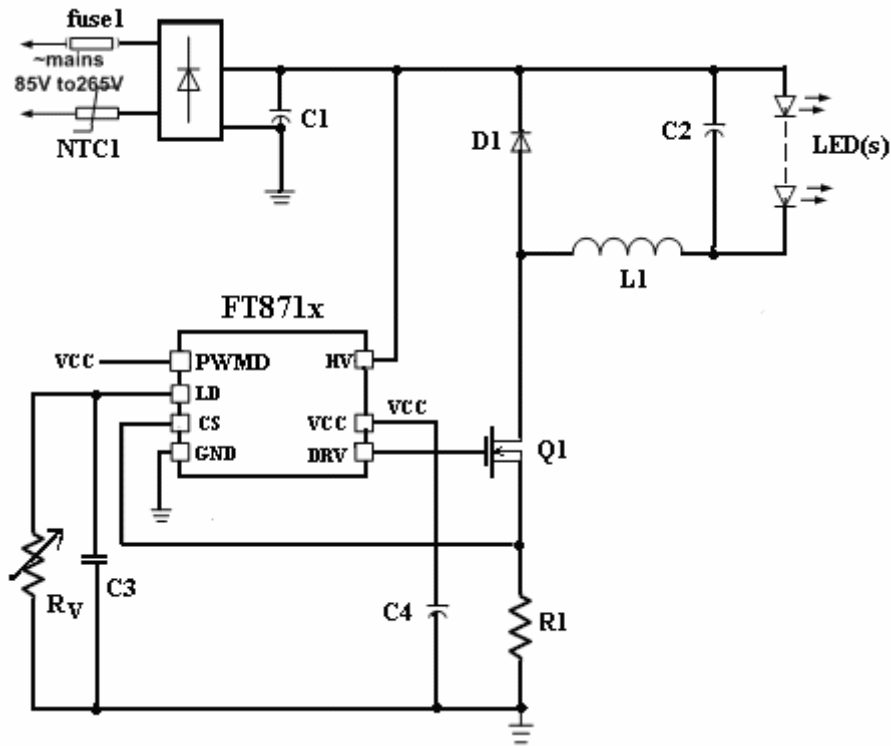

Figure 1. Typical Application Circuit

ABSOLUTE MAXIMUM RATINGS

VCC to GND.....	-0.3V to +40V
LD to GND.....	-0.3V to +9V
CS to GND.....	-0.3V to +9V
DRV to GND.....	-0.3V to +40V
HV to GND.....	-0.3V to +500V
PWMD to GND.....	-0.3V to +20V
Operating Temperature Range.....	-40°C to +125°C
Junction Temperature.....	-40°C to +150°C
Storage Temperature Range.....	-60°C to +150°C

Stresses exceeding Maximum Ratings may damage the device. Maximum Ratings are stress ratings only. Functional operation above the Recommended Operating Conditions is not implied. Extended exposure to stresses above the Recommended Operating Conditions may affect device reliability.

PIN CONFIGURATION

SOP8/DIP8

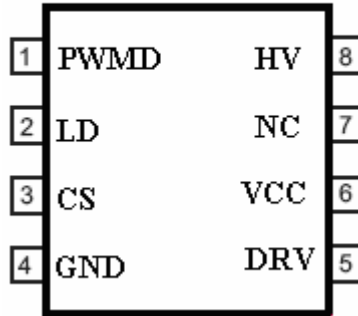

Figure 2. Pin Configuration (Top View)

TERMINAL FUNCTIONS

PIN	NAME	FUNCTION	DESCRIPTION
1	PWMD	PWM dimming	This is the PWM dimming input of the IC. Duty cycle (2KHz) controls the LED average output current. When this pin is pulled to GND, the gate driver is turned off. When the pin is pulled high, the gate driver operates normally.
2	LD	Linear dimming	Linear dimming achieved by adjusting the current limit threshold at current sense comparator through connecting programmable resistor R_v to the pin 2.
3	CS	Current Sense	Senses LED string current.
4	GND	IC Ground	Ground.
5	DRV	Driver Output	Gate driver output to drive the external MOSEFET.
6	VCC	Supply Voltage	This is the power supply pin for all internal circuits. It must be bypassed with a low ESR capacitor to GND.
7	NC	NC	Unconnected Pin.
8	HV	High Voltage	Input voltage 15V to 500V.

ORDERING INFORMATION

FT871①②

DESIGNATOR	SYMBOL	SWITCHING FREQUENCY
①	A	33KHz
	B	25KHz
②	SYMBOL	PACKAGE TYPE
	a	SOP8
	b	DIP8

MARKING RULING

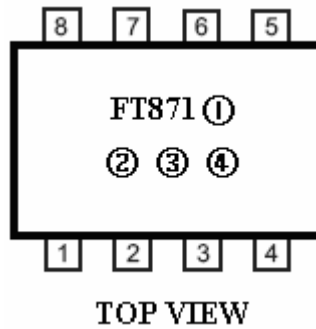

① represents frequency option (A:33KHz; B:25KHz)

②③④ for internal reference

BLOCK DIAGRAM

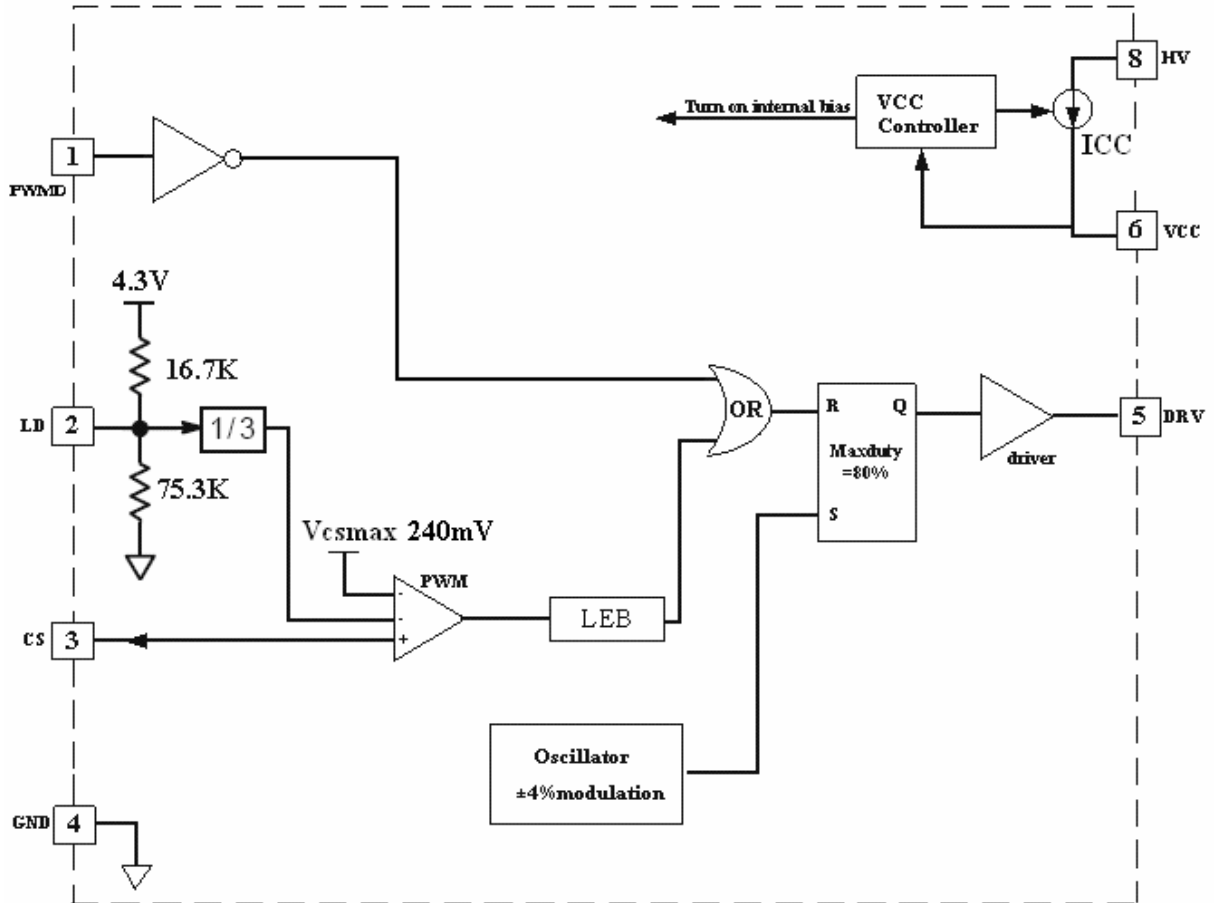

Figure 3. Block Diagram



ELECTRICAL CHARACTERISTICS

For typical values Tj=25°C, for min/max values, Tj=-40°C to +125°C, Vcc=10V, HV=open, PWMD=10V, FB=2V, CS=Ground, DRV=1nF, unless otherwise noted

Symbol	Parameter	Min	Typ	Max	Units	Conditions
V _{indc}	Input DC supply voltage rang	15		500	V	
I _{op}	Internal IC consumption,		1.2		mA	1nF at DRV
VCC	Internally regulated voltage	9	9.68	10	V	
Δ Vcc,line	Line regulation of Vcc	0	-	1	V	VHV=15-500V
Δ Vcc,load	Load regulation of Vcc			0.5	V	Ivcc(out)=1mA, 1nF at gate, PWMD=Vcc
UVLO	V _{CC} under voltage lockout threshold		8.5		V	
Δ UVLO	V _{CC} under voltage lockout hysteresis		200		mV	
V _{csmax}	Maximum Current sense voltage	225	240	255	mV	
F _{osc}	Oscillator frequency	30	33	36	KHz	FT871A
		22	25	28		FT871B
Δ F _{osc}	Oscillator Modulation Swing, in Percentage of Fosc		±4		%	
D _{max}	Maximum PWM duty cycle		80		%	
V _{ld}	Linear dimming pin voltage range	0		240	mV	
T _{LEB}	Leading Edge Blanking Duration		350		ns	
T _{delay}	Delay from CS trip to gate output		60	150	ns	
V _{gate(hi)}	Gate high output voltage	Vcc-0.5			V	
V _{gate(lo)}	Gate low output voltage			0.5	V	
T _{rise}	Gate output rise time		140		ns	C4=1nF;
T _{fall}	Gate output fall time		80		ns	C4=1nF;

PACKAGE INFORMATION

SOP8 Package

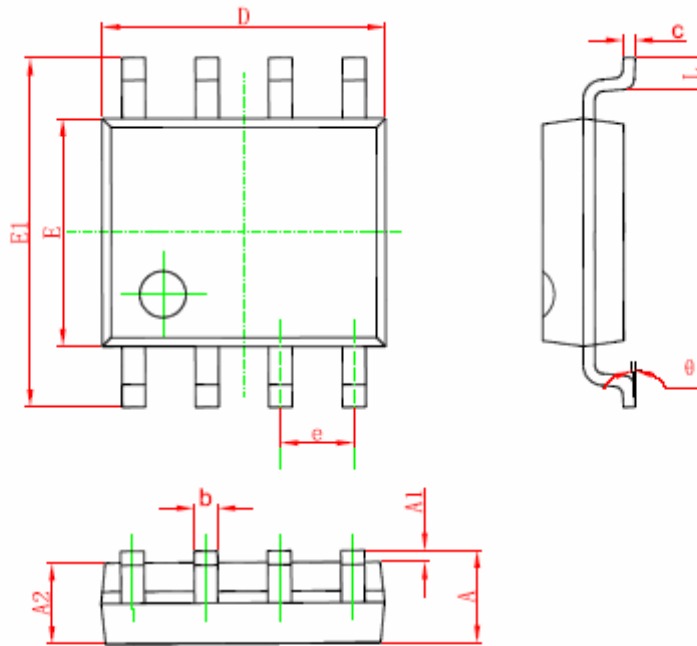

Symbol	Dimensions In Millimeters		Dimensions In Inches	
	Min	Max	Min	Max
A	1.350	1.750	0.053	0.069
A1	0.100	0.250	0.004	0.010
A2	1.350	1.550	0.053	0.061
b	0.330	0.510	0.013	0.020
c	0.170	0.250	0.006	0.010
D	4.700	5.100	0.185	0.200
E	3.800	4.000	0.150	0.157
E1	5.800	6.200	0.228	0.244
e	1.270 (BSC)		0.050 (BSC)	
L	0.400	1.270	0.016	0.050
θ	0°	8°	0°	8°

DIP8 Package

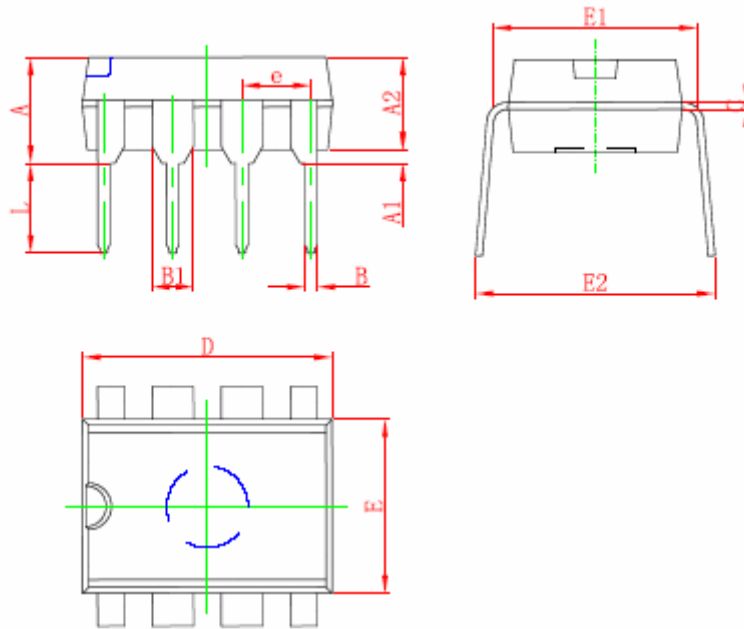

Symbol	Dimensions In Millimeters		Dimensions In Inches	
	Min	Max	Min	Max
A	3.710	4.310	0.146	0.170
A1	0.510		0.020	
A2	3.200	3.600	0.126	0.142
B	0.380	0.570	0.015	0.022
B1	1.524 (BSC)		0.060 (BSC)	
C	0.204	0.360	0.008	0.014
D	9.000	9.400	0.354	0.370
E	6.200	6.600	0.244	0.260
E1	7.320	7.920	0.288	0.312
e	2.540 (BSC)		0.100 (BSC)	
L	3.000	3.600	0.118	0.142
E2	8.400	9.000	0.331	0.354