

WHITE LED STEP-UP CONVERTER**AP3030****General Description**

The AP3030 is an inductor-based DC/DC converter designed to drive up to eight white LEDs in series or 2 rows of LEDs with 5 for each in parallel for backlight. Only one feedback resistor is needed to control the LED current and obtain satisfied brightness.

A constant frequency 1.2MHz PWM control scheme is employed in this IC, which means tiny external components can be used. Specifically, 1mm tall inductor and 0.22 μ F output capacitor for the typical application are sufficient. Additionally, the schottky diode in boost circuit is integrated in this chip. AP3030 also provides a disable port to ease its use for different systems.

The output over-voltage protection is implemented in AP3030. When any LED is broken or in other abnormal conditions, the output voltage will be clamped to 30V.

The AP3030 is available in standard SOT-23-6 and TSOT-23-6 packages.

Features

- Inherently Uniform LED Current
- High Efficiency up to 84%
- No Need for Extra Schottky Diode
- Output Over-Voltage Protection (OVP)
- Drives up to 8 LEDs in Series or 2 Rows of LEDs with 5 for Each in Parallel
- Fixed 1.2MHz Switching Frequency
- Uses Tiny 1mm Tall Inductor
- Requires Only 0.22 μ F Output Capacitor

Applications

- Cellular Phones
- Digital Cameras
- LCD modules
- GPS Receivers
- PDAs, Handheld Computers

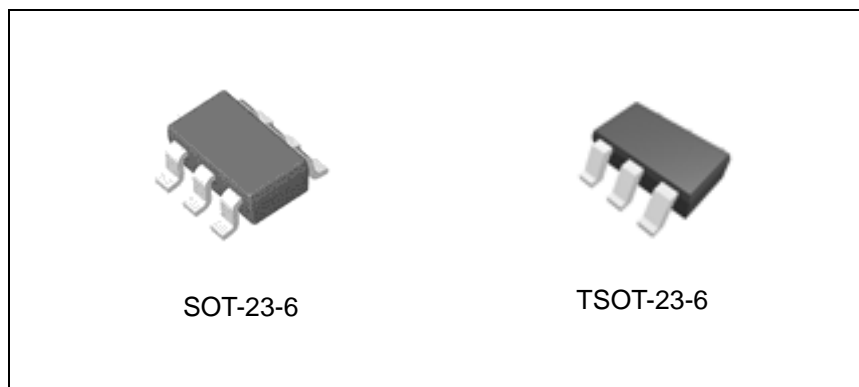

Figure 1. Package Types of AP3030

WHITE LED STEP-UP CONVERTER
AP3030
Pin Configuration

Figure 2. Pin Configuration of AP3030 (Top View)

Pin Description

Pin Number	Pin Name	Function
1	SW	Switch Pin. Connect external inductor
2	GND	Ground
3	FB	Voltage Feedback. Reference voltage is 200mV
4	CTRL	Shutdown and Dimming Pin. Connect to 1.8V or higher to enable device; Connect to 50mV or less to disable device; Connect to a voltage between 1.8V and 50mV to achieve linear dimming
5	V_{OUT}	Output Pin. Connected to the cathode of internal schottky diode
6	V_{IN}	Input Supply Pin. Must be locally bypassed

WHITE LED STEP-UP CONVERTER

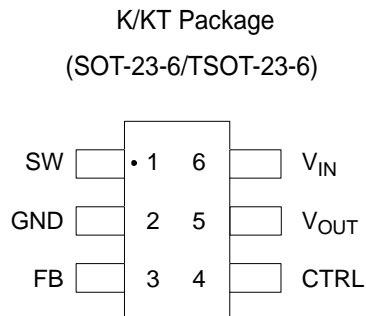
AP3030

Functional Block Diagram

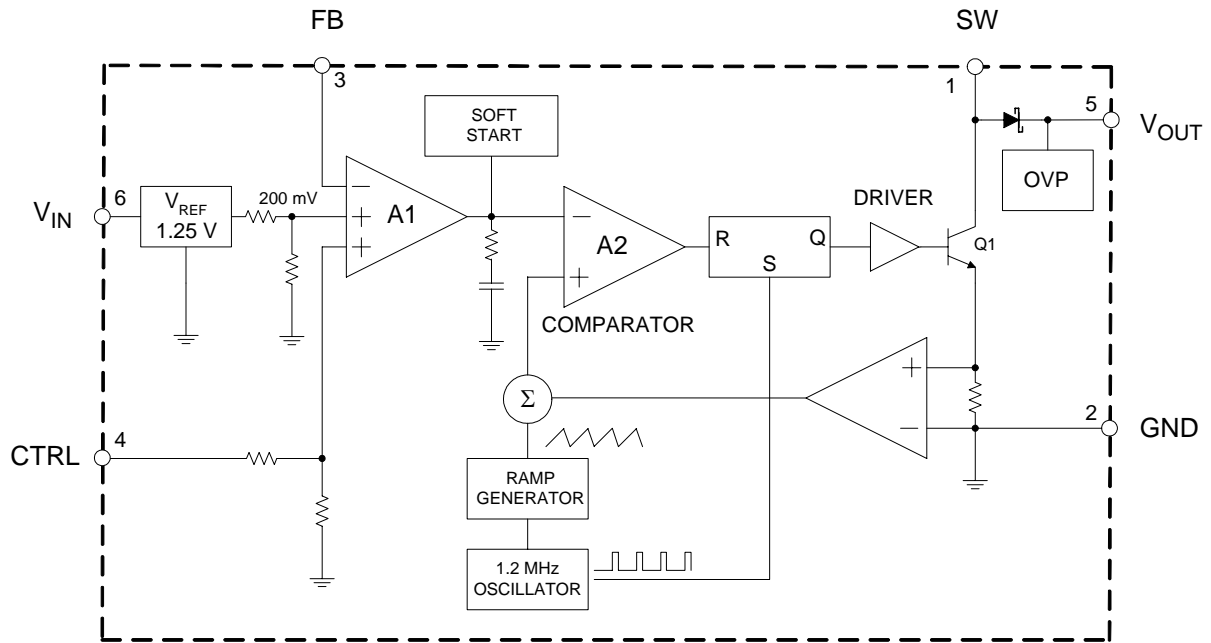
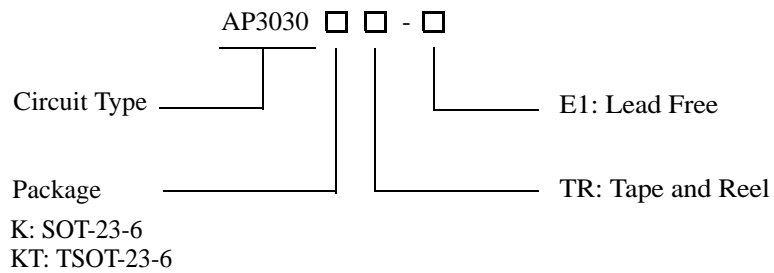

Figure 3. Functional Block Diagram of AP3030

Ordering Information



Package	Temperature Range	Part Number	Marking ID	Packing Type
SOT-23-6	-40 to 85°C	AP3030KTR-E1	EEB	Tape & Reel
TSOT-23-6	-40 to 85°C	AP3030KTTR-E1	S9G	Tape & Reel

BCD Semiconductor's Pb-free products, as designated with "E1" suffix in the part number, are RoHS compliant.

**WHITE LED STEP-UP CONVERTER****AP3030****Absolute Maximum Ratings (Note 1)**

Parameter	Symbol	Value	Unit
Input Voltage	V_{IN}	20	V
SW Voltage	V_{SW}	30	V
FB Voltage	V_{FB}	20	V
CTRL Voltage	V_{CTRL}	20	V
Thermal Resistance (Junction to Atmosphere, no Heat sink)	$R_{\theta JA}$	265	°C/W
Operating Junction Temperature	T_J	150	°C
Storage Temperature Range	T_{STG}	-65 to 150	°C
Lead Temperature (Soldering, 10sec)	T_{LEAD}	260	°C
ESD (Machine Model)		250	V
ESD (Human Body Model)		2000	V

Note 1: Stresses greater than those listed under "Absolute Maximum Ratings" may cause permanent damage to the device. These are stress ratings only, and functional operation of the device at these or any other conditions beyond those indicated under "Recommended Operating Conditions" is not implied. Exposure to "Absolute Maximum Ratings" for extended periods may affect device reliability.

Recommended Operating Conditions

Parameter	Symbol	Min	Max	Unit
Operating Temperature Range	T_{OP}	-40	85	°C
Input Voltage	V_{IN}	2.5	16	V
CTRL Voltage	V_{CTRL}		16	V

**WHITE LED STEP-UP CONVERTER****AP3030****Electrical Characteristics** $(V_{IN}=3V, V_{CTRL}=3V, T_A=25^{\circ}C, \text{ unless otherwise specified.})$

Parameter	Symbol	Conditions	Min	Typ	Max	Unit
Minimum Operating Voltage	$V_{IN(min)}$		2.5			V
Maximum Operating Voltage	$V_{IN(max)}$				16	
Feedback Voltage	V_{FB}	$I_{OUT}=20mA, 4 \text{ LEDs},$ $T_A=-40^{\circ}C \text{ to } 85^{\circ}C$	188	200	212	mV
FB Pin Bias Current	I_{FB}			35	100	nA
Supply Current	I_{CC}	$V_{FB}=V_{IN}, \text{ Not Switching}$	1.5	2.5	3.2	mA
Supply Current	I_Q	$V_{CTRL}=0V$	2.0	3.2	5.0	μA
Switching Frequency	f		0.9	1.2	1.5	MHz
Maximum Duty Cycle	D_{MAX}		90	93		%
Switch Current Limit (Note 2)	I_{LIMIT}	D=40%		550		mA
		D=80%		550		
Switch V_{CE} Saturation Voltage	V_{CESAT}	$I_{SW}=250mA$		360		mV
Switch Leakage Current		$V_{SW}=5V$		0.01	5	μA
CTRL Pin Voltage	V_{CTRL}	High	1.8			V
		Low			0.05	
CTRL Pin Bias Current	I_{CTRL}		40	55	72	μA
		$T_A=85^{\circ}C$		50		
		$T_A=-40^{\circ}C$		75		
Schottky Forward Drop	V_{DROP}	$I_D=150mA$		0.7		V
Schottky Leakage Current		$V_R=23V$		0.1	4	μA
		$V_R=27V$			150	
Soft Start Time	t			300		μS

Note 2: The Switch Current Limit is related to Duty Cycle. Please refer to Figure 16 for detail.

Note 3: The bold type specification of full temperature range is Guaranteed By Design (GBD).



WHITE LED STEP-UP CONVERTER

AP3030

Typical Performance Characteristics

(V_F of WLED is 3.45V @ $I_F=20mA$, unless otherwise noted)

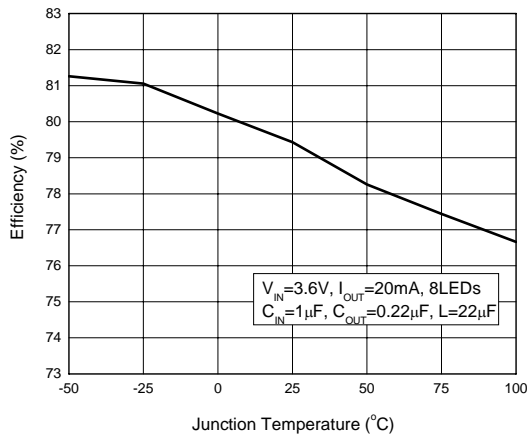

Figure 4. Efficiency vs. Junction Temperature

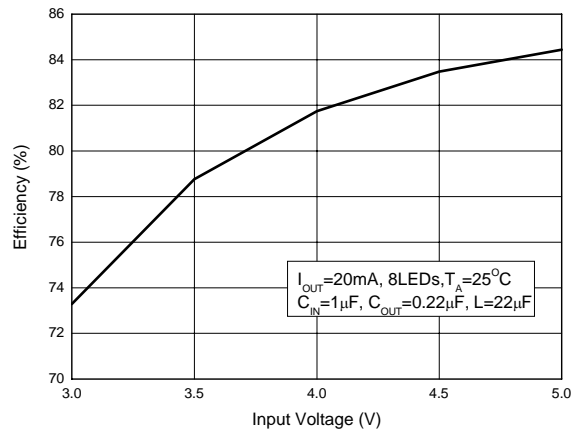

Figure 5. Efficiency vs. Input Voltage

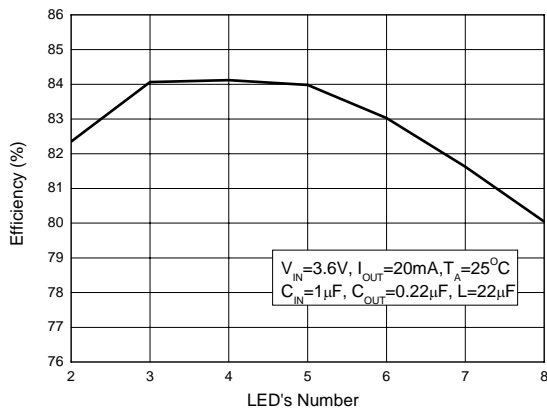

Figure 6. Efficiency vs. LED's Number

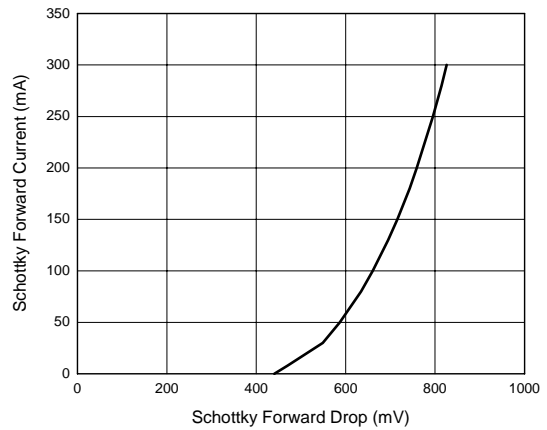

Figure 7. Schottky Forward Current vs. Schottky Forward Drop



WHITE LED STEP-UP CONVERTER

AP3030

Typical Performance Characteristics (Continued)

(V_F of WLED is 3.45V @ $I_F=20mA$, unless otherwise noted)

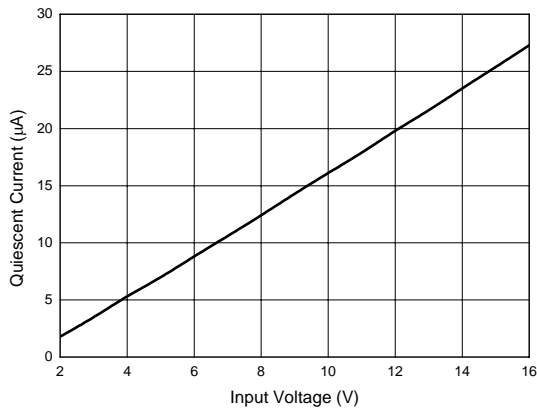

Figure 8. Shutdown Quiescent Current vs. Input Voltage

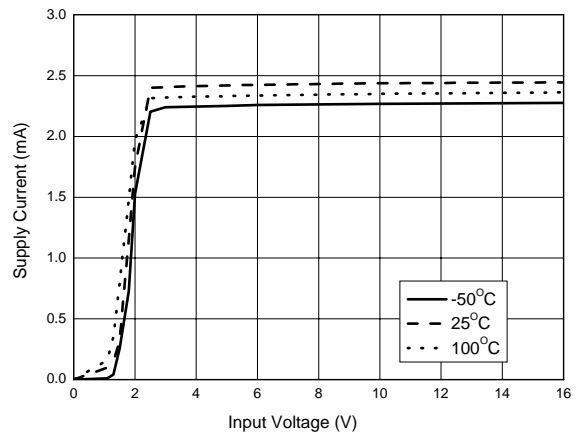

Figure 9. Supply Current vs. Input Voltage

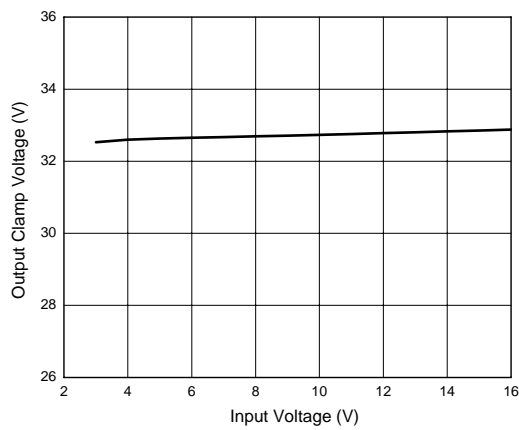

Figure 10. Output Clamp Voltage vs. Input Voltage

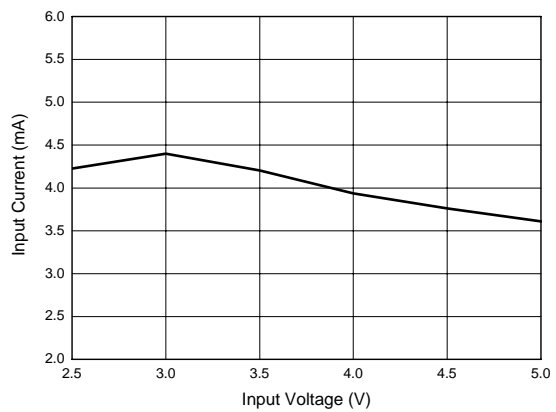

Figure 11. Input Current in Output Open Circuit vs. Input Voltage



WHITE LED STEP-UP CONVERTER

AP3030

Typical Performance Characteristics (Continued)

(V_F of WLED is 3.45V @ $I_F=20mA$, unless otherwise noted)

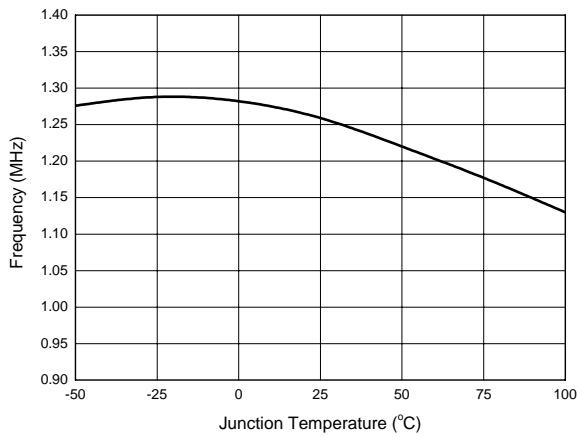

Figure 12. Switching Frequency vs. Junction Temperature

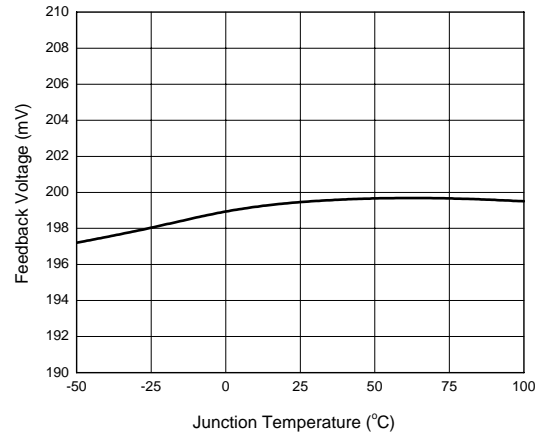

Figure 13. Feedback Voltage vs. Junction Temperature

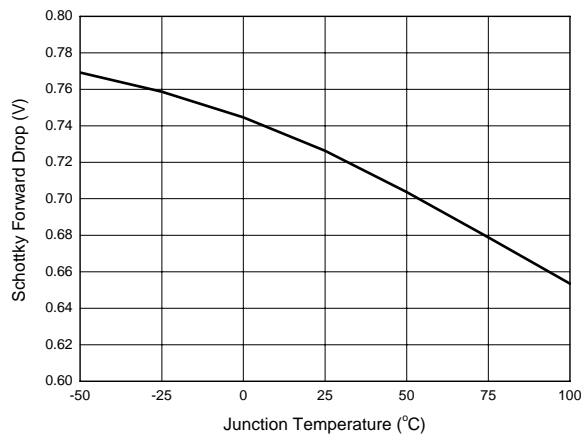

Figure 14. Schottky Forward Drop vs. Junction Temperature

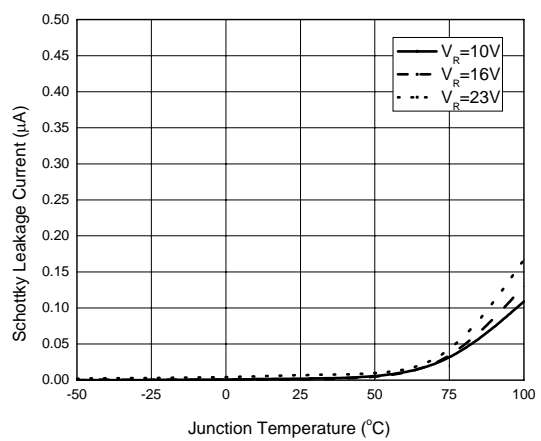

Figure 15. Schottky Leakage Current vs. Junction Temperature



WHITE LED STEP-UP CONVERTER

AP3030

Typical Performance Characteristics (Continued)

(V_F of WLED is 3.45V @ $I_F=20mA$, unless otherwise noted)

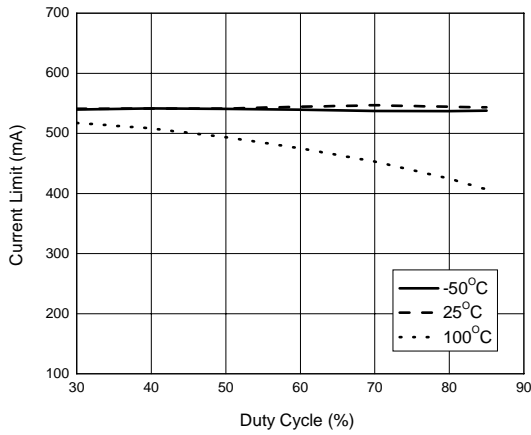

Figure 16. Switch Current Limit vs. Duty Cycle

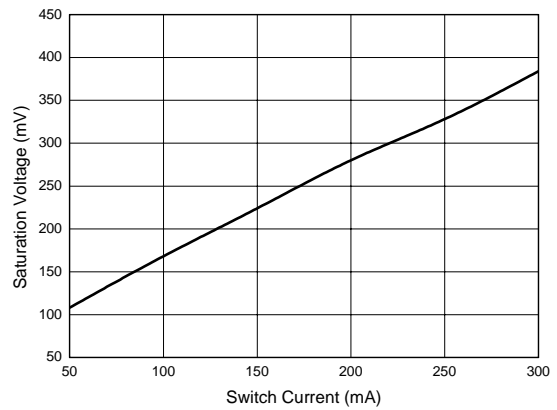

Figure 17. Switch Saturation Voltage vs. Switch Current

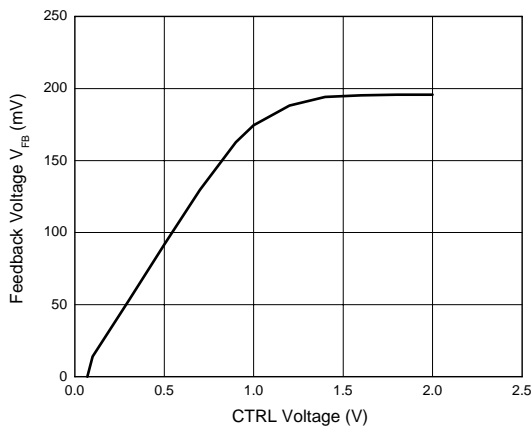
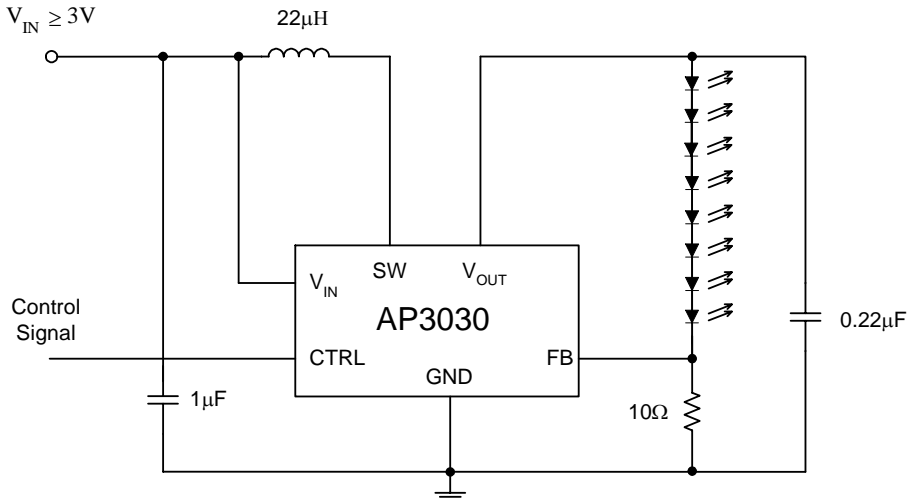
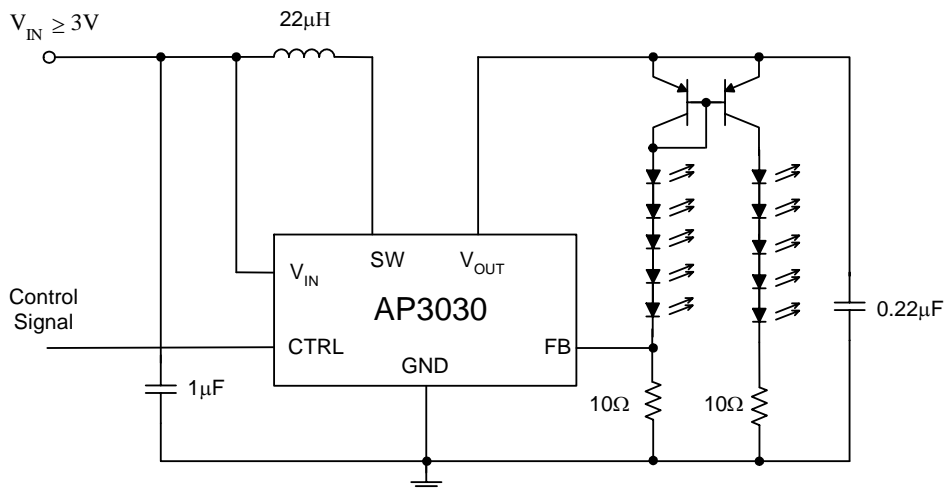

Figure 18. Feedback Voltage vs. CTRL Pin Voltage

WHITE LED STEP-UP CONVERTER
AP3030
Typical Application

C: X5R or X7R Dielectric
 L: SUMIDA CDRH5D28R-220NC or Equivalent
 This circuit can work in full temperature

Figure 4. Typical Application of Eight LED Drivers



C: X5R or X7R Dielectric
 L: SUMIDA CDRH5D28R-220NC or Equivalent
 Two transistors are recommended to use Dual Matched transistor pairs
 This circuit can work in full temperature

Figure 5. Typical Application of Ten LED Drivers



WHITE LED STEP-UP CONVERTER

AP3030

Mechanical Dimensions

SOT-23-6

Unit: mm(inch)

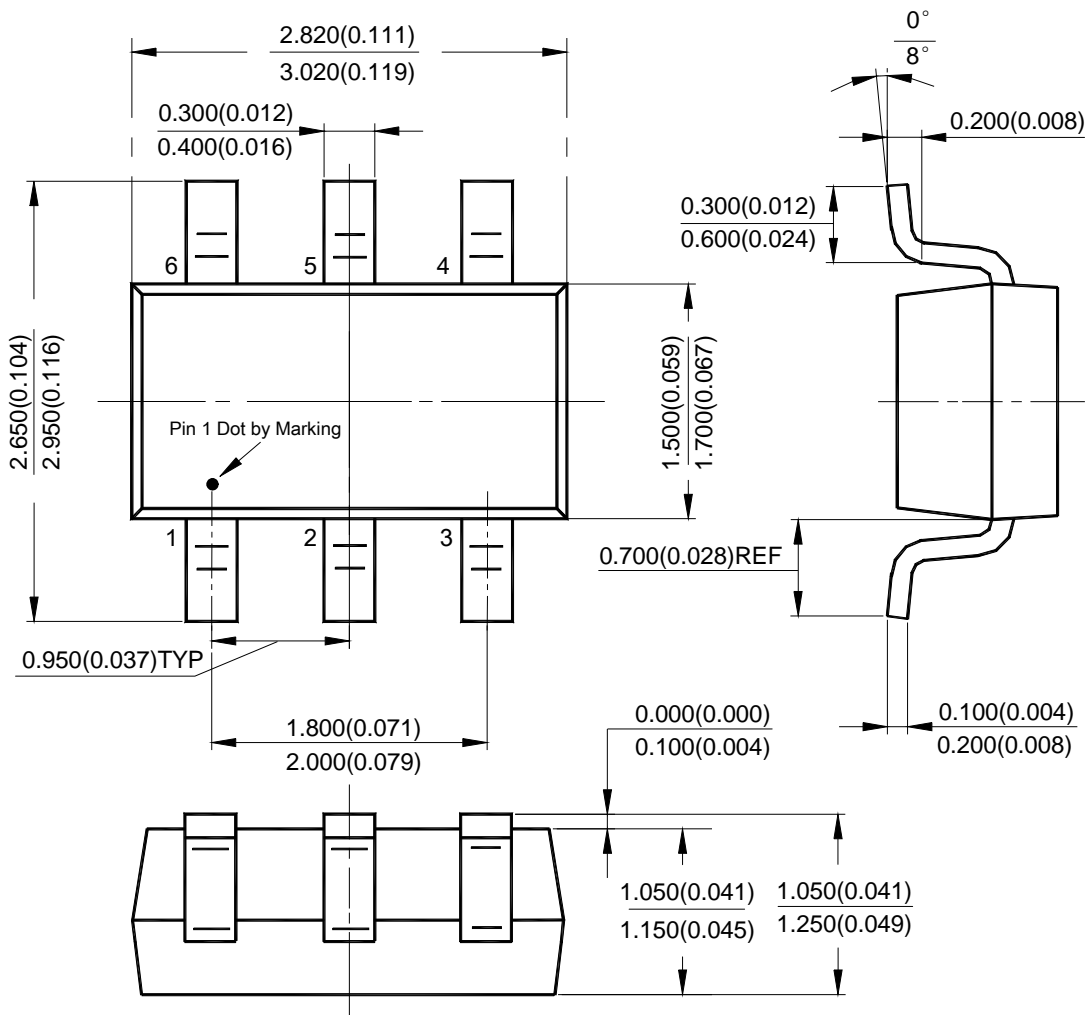



WHITE LED STEP-UP CONVERTER

AP3030

Mechanical Dimensions

TSOT-23-6

Unit: mm(inch)

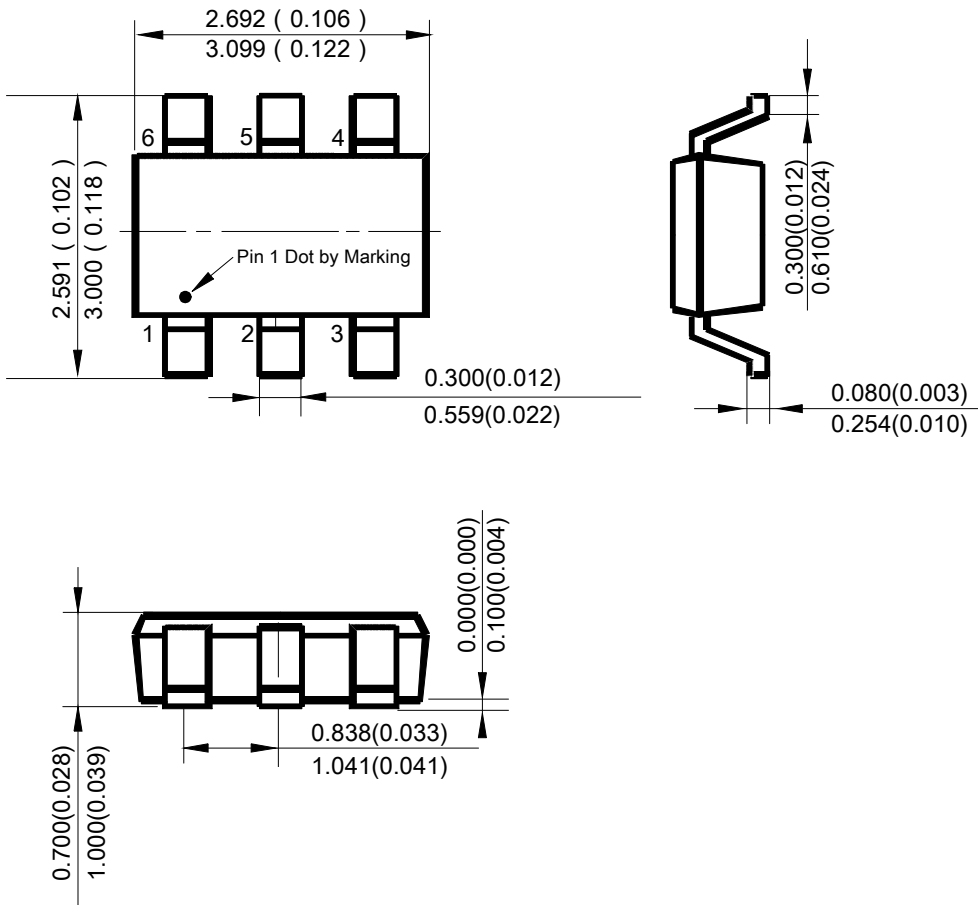



BCD Semiconductor Manufacturing Limited

<http://www.bcdsemi.com>

IMPORTANT NOTICE

BCD Semiconductor Manufacturing Limited reserves the right to make changes without further notice to any products or specifications herein. BCD Semiconductor Manufacturing Limited does not assume any responsibility for use of any its products for any particular purpose, nor does BCD Semiconductor Manufacturing Limited assume any liability arising out of the application or use of any its products or circuits. BCD Semiconductor Manufacturing Limited does not convey any license under its patent rights or other rights nor the rights of others.

MAIN SITE

- Headquarters

BCD Semiconductor Manufacturing Limited

No. 1600, Zi Xing Road, Shanghai Zizhu Science-based Industrial Park, 200241, China
Tel: +86-21-24162266, Fax: +86-21-24162277

- Wafer Fab

Shanghai SIM-BCD Semiconductor Manufacturing Co., Ltd.

800 Yi Shan Road, Shanghai 200233, China
Tel: +86-21-6485 1491, Fax: +86-21-5450 0008

REGIONAL SALES OFFICE

Shenzhen Office

Shanghai SIM-BCD Semiconductor Manufacturing Co., Ltd., Shenzhen Office
Room E, 5F, Noble Center, No.1006, 3rd Fuzhong Road, Futian District, Shenzhen,
518026, China
Tel: +86-755-8826 7951
Fax: +86-755-8826 7865

Taiwan Office

BCD Semiconductor (Taiwan) Company Limited
4F, 298-1, Rui Guang Road, Nei-Hu District, Taipei,
Taiwan
Tel: +886-2-2656 2808
Fax: +886-2-2656 2806

USA Office

BCD Semiconductor Corp.
30920 Huntwood Ave. Hayward,
CA 94544, USA
Tel : +1-510-324-2988
Fax: +1-510-324-2788