

UL 498

## Attachment Plugs and Receptacles

*UL COPYRIGHTED MATERIAL –  
NOT AUTHORIZED FOR FURTHER REPRODUCTION OR  
DISTRIBUTION WITHOUT PERMISSION FROM UL*

**UL COPYRIGHTED MATERIAL –  
NOT AUTHORIZED FOR FURTHER REPRODUCTION OR  
DISTRIBUTION WITHOUT PERMISSION FROM UL**

Underwriters Laboratories Inc. (UL)  
333 Pfingsten Road  
Northbrook, IL 60062-2096

UL Standard for Safety for Attachment Plugs and Receptacles, UL 498

Fourteenth Edition, Dated December 26, 2001

Revisions: This Standard contains revisions through and including November 16, 2007.

### **SUMMARY OF TOPICS**

***This revision to ANSI/UL 498 incorporates the following:***

***Revision to Abrupt Removal Test to Correct the Number of Samples Required***

***Revision of Requirements to Permit the Grounding Symbol With or Without the Circle***

***Revision of Note #2 Appearing in Figure 105.1 to Specify a Range of Radius for the Blades of the Test Gauge***

***Revision to the Overload Test Requirements Regarding the Fuses Used in the Test Circuit***

***Additional revisions to address universal upkeep of UL Standards for Safety. These revisions are considered to be non-substantive and not subject to UL's STP process.***

Text that has been changed in any manner is marked with a vertical line in the margin. Changes in requirements are marked with a vertical line in the margin and are followed by an effective date note indicating the date of publication or the date on which the changed requirement becomes effective.

The new and revised requirements are substantially in accordance with UL's Proposal(s) on this subject dated September 7, 2007.

The revisions dated November 16, 2007 include a reprinted title page (page1) for this Standard.

As indicated on the title page (page 1), this UL Standard for Safety is an American National Standard. Attention is directed to the note on the title page of this Standard outlining the procedures to be followed to retain the approved text of this ANSI/UL Standard.

As indicated on the title page (page1), this UL Standard for Safety has been adopted by the Department of Defense.

The UL Foreword is no longer located within the UL Standard. For information concerning the use and application of the requirements contained in this Standard, the current version of the UL Foreword is located on ULStandardsInfoNet at: <http://ulstandardsinfo.net/ulforeword.html>

The master for this Standard at UL's Northbrook Office is the official document insofar as it relates to a UL service and the compliance of a product with respect to the requirements for that product and service, or if there are questions regarding the accuracy of this Standard.

***UL COPYRIGHTED MATERIAL –  
NOT AUTHORIZED FOR FURTHER REPRODUCTION OR  
DISTRIBUTION WITHOUT PERMISSION FROM UL***

UL's Standards for Safety are copyrighted by UL. Neither a printed copy of a Standard, nor the distribution diskette for a Standard-on-Diskette and the file for the Standard on the distribution diskette should be altered in any way. All of UL's Standards and all copyrights, ownerships, and rights regarding those Standards shall remain the sole and exclusive property of UL.

All rights reserved. No part of this publication may be reproduced, stored in a retrieval system, or transmitted in any form by any means, electronic, mechanical photocopying, recording, or otherwise without prior permission of UL.

Revisions of UL Standards for Safety are issued from time to time. A UL Standard for Safety is current only if it incorporates the most recently adopted revisions.

UL provides this Standard "as is" without warranty of any kind, either expressed or implied, including but not limited to, the implied warranties of merchantability or fitness for any purpose.

In no event will UL be liable for any special, incidental, consequential, indirect or similar damages, including loss of profits, lost savings, loss of data, or any other damages arising out of the use of or the inability to use this Standard, even if UL or an authorized UL representative has been advised of the possibility of such damage. In no event shall UL's liability for any damage ever exceed the price paid for this Standard, regardless of the form of the claim.

UL will attempt to answer support requests concerning electronic versions of its Standards. However, this support service is offered on a reasonable efforts basis only, and UL may not be able to resolve every support request. UL supports the electronic versions of its Standards only if they are used under the conditions and operating systems for which it is intended. UL's support policies may change from time-to-time without notification.

UL reserves the right to change the format, presentation, file types and formats, delivery methods and formats, and the like of both its printed and electronic Standards without prior notice.

Purchasers of the electronic versions of UL's Standards for Safety agree to defend, indemnify, and hold UL harmless from and against any loss, expense, liability, damage, claim, or judgement (including reasonable attorney's fees) resulting from any error or deviation introduced while purchaser is storing an electronic Standard on the purchaser's computer system.

If a single-user version electronic Standard was purchased, one copy of this Standard may be stored on the hard disk of a single personal computer, or on a single LAN file-server or the permanent storage device of a multiple-user computer in such a manner that this Standard may only be accessed by one user at a time and for which there is no possibility of multiple concurrent access.

If a multiple-user version electronic Standard was purchased, one copy of the Standard may be stored on a single LAN file-server, or on the permanent storage device of a multiple-user computer, or on an Intranet server. The number of concurrent users shall not exceed the number of users authorized.

Electronic Standards are intended for on-line use, such as for viewing the requirements of a Standard, conducting a word search, and the like. Only one copy of the Standard may be printed from each single-user version of an electronic Standard. Only one copy of the Standard may be printed for each authorized user of a multiple-user version of an electronic Standard. Because of differences in the computer/software/printer setup used by UL and those of electronic Standards purchasers, the printed copy obtained by a purchaser may not look exactly like the on-line screen view or the printed Standard.

An employee of an organization purchasing a UL Standard can make a copy of the page or pages being viewed for their own fair and/or practical internal use.

UL COPYRIGHTED MATERIAL –  
NOT AUTHORIZED FOR FURTHER REPRODUCTION OR  
DISTRIBUTION WITHOUT PERMISSION FROM UL

The requirements in this Standard are now in effect, except for those paragraphs, sections, tables, figures, and/or other elements of the Standard having future effective dates as indicated in the note following the affected item. The prior text for requirements that have been revised and that have a future effective date are located after the Standard, and are preceded by a "SUPERSEDED REQUIREMENTS" notice.

New product submittals made prior to a specified future effective date will be judged under all of the requirements in this Standard including those requirements with a specified future effective date, unless the applicant specifically requests that the product be judged under the current requirements. However, if the applicant elects this option, it should be noted that compliance with all the requirements in this Standard will be required as a condition of continued Listing, Recognition, and Follow-Up Services after the effective date, and understanding of this should be signified in writing.

Copyright © 2007 Underwriters Laboratories Inc.

*UL COPYRIGHTED MATERIAL –  
NOT AUTHORIZED FOR FURTHER REPRODUCTION OR  
DISTRIBUTION WITHOUT PERMISSION FROM UL*

This Standard consists of pages dated as shown in the following checklist:

Page	Date
1 .....	November 16, 2007
2-3 .....	May 14, 2004
4-7 .....	November 16, 2007
8-9 .....	December 26, 2001
10 .....	May 25, 2007
11 .....	November 16, 2007
12 .....	May 25, 2007
13 .....	December 26, 2001
14 .....	May 14, 2004
15 .....	November 16, 2007
16-16B .....	May 25, 2007
17 .....	December 26, 2001
18 .....	May 25, 2007
19-29 .....	December 26, 2001
30 .....	November 16, 2007
31 .....	December 26, 2001
32 .....	November 16, 2007
33-36 .....	December 26, 2001
37-38B .....	March 15, 2006
39-41 .....	December 26, 2001
42 .....	November 16, 2007
43-44 .....	December 26, 2001
45 .....	November 16, 2007
46 .....	October 23, 2002
47-52 .....	December 26, 2001
53-54B .....	November 16, 2007
55-57 .....	December 26, 2001
58 .....	May 25, 2007
59-62 .....	December 26, 2001
63-65 .....	November 16, 2007
66 .....	December 26, 2001
67-68 .....	November 16, 2007
69 .....	March 15, 2006
70-70B .....	October 23, 2002
71-72 .....	November 16, 2007
73-79 .....	December 26, 2001
80-81 .....	November 16, 2007
82-85 .....	December 26, 2001
86-94B .....	November 16, 2007
95-102 .....	December 26, 2001
103 .....	May 14, 2004
104 .....	November 16, 2007
105-108 .....	December 26, 2001
109-114B .....	November 16, 2007
115-117 .....	March 15, 2006
118 .....	November 16, 2007
118A-118B .....	March 15, 2006
119 .....	December 26, 2001
120-122B .....	November 16, 2007

**UL COPYRIGHTED MATERIAL –  
NOT AUTHORIZED FOR FURTHER REPRODUCTION OR  
DISTRIBUTION WITHOUT PERMISSION FROM UL**

123-129	December 26, 2001
130	May 14, 2004
131	November 16, 2007
132	December 26, 2001
133	October 23, 2002
134-135	November 16, 2007
136	December 26, 2001
137	November 16, 2007
138-146	December 26, 2001
147	November 16, 2007
148-150	December 26, 2001
151-152	March 15, 2006
153-162	December 26, 2001
163-164B	November 16, 2007
165-175	December 26, 2001
176-176B	November 16, 2007
177	December 26, 2001
178-179	November 16, 2007
180	December 26, 2001
181	November 16, 2007
182-187	December 26, 2001
188	November 16, 2007
189-192	December 26, 2001
193	November 16, 2007
194-210	December 26, 2001
211	November 16, 2007
212-212B	March 15, 2006
213-214	December 26, 2001
215-216	November 16, 2007
217-221	December 26, 2001
222	November 16, 2007
223	May 14, 2004
224	March 15, 2006
225	November 16, 2007
226	December 26, 2001
SA1	May 25, 2007
SA2	December 26, 2001
SB1	May 14, 2004
SB2-SB10	December 26, 2001
SC1-SC10	December 26, 2001
SD1	December 26, 2001
SD2-SD3	October 23, 2002
SD4	November 16, 2007
SD5-SD11	December 26, 2001
SD12-SD12B	November 16, 2007
SD13-SD16	December 26, 2001
SD17	November 16, 2007
SD18	December 26, 2001
SD19-SD20	November 16, 2007
SD21-SD28	December 26, 2001
SD29	November 16, 2007
SD30-SD32	December 26, 2001
SD33-SD34	May 25, 2007

**UL COPYRIGHTED MATERIAL –  
NOT AUTHORIZED FOR FURTHER REPRODUCTION OR  
DISTRIBUTION WITHOUT PERMISSION FROM UL**

SE1-SE6 ..... May 25, 2007  
A1-A2 ..... November 16, 2007  
B1 ..... November 16, 2007  
B2 ..... March 15, 2006  
B3-B4 ..... December 26, 2001  
B5 ..... May 25, 2007  
B6 ..... December 26, 2001

Document Was Downloaded By jianxiong chen For Use By KAI HUA (FOSHAN SHUNDE) ELECTRIC APPLIANCE CO LTD 22381 : 5/8/2008 - 10:34 AM

**UL COPYRIGHTED MATERIAL –  
NOT AUTHORIZED FOR FURTHER REPRODUCTION OR  
DISTRIBUTION WITHOUT PERMISSION FROM UL**



DECEMBER 26, 2001  
(Title Page Reprinted: November 16, 2007)



ANSI/UL 498-2007

1

## UL 498

### Standard for Attachment Plugs and Receptacles

First Edition – December, 1931  
Second Edition – September, 1939  
Third Edition – June, 1942  
Fourth Edition – November, 1948  
Fifth Edition – September, 1952  
Sixth Edition – November, 1954  
Seventh Edition – December, 1959  
Eighth Edition – May, 1962  
Ninth Edition – April, 1974  
Tenth Edition – September, 1981  
Eleventh Edition – November, 1986  
Twelfth Edition – April, 1991  
Thirteenth Edition – April, 1996

### Fourteenth Edition

**December 26, 2001**

The most recent designation of ANSI/UL 498 as an American National Standard (ANSI) occurred on November 13, 2007. The ANSI approval for this standard does not include the Cover Page, Transmittal Pages, Title Page, or effective date information.

This ANSI/UL Standard for Safety consists of the Fourteenth edition including revisions through November 16, 2007.

The Department of Defense (DoD) has adopted UL 498 on August 17, 1981. The publication of revised pages or a new edition of this Standard will not invalidate the DoD adoption.

Comments or proposals for revisions on any part of the Standard may be submitted to UL at any time. Proposals should be submitted via a Proposal Request in UL's On-Line Collaborative Standards Development System (CSDS) at <http://csds.ul.com>.

UL's Standards for Safety are copyrighted by UL. Neither a printed nor electronic copy of a Standard should be altered in any way. All of UL's Standards and all copyrights, ownerships, and rights regarding those Standards shall remain the sole and exclusive property of UL.

COPYRIGHT © 2007 UNDERWRITERS LABORATORIES INC.

***UL COPYRIGHTED MATERIAL –  
NOT AUTHORIZED FOR FURTHER REPRODUCTION OR  
DISTRIBUTION WITHOUT PERMISSION FROM UL***

No Text on This Page

***UL COPYRIGHTED MATERIAL –  
NOT AUTHORIZED FOR FURTHER REPRODUCTION OR  
DISTRIBUTION WITHOUT PERMISSION FROM UL***

## CONTENTS

### INTRODUCTION

1 Scope .....	15
2 Glossary .....	16
3 Components .....	19
4 Units of Measurement .....	19
5 References .....	19

### CONSTRUCTION

#### ALL DEVICES

6 General .....	19
7 Configurations .....	20
8 Insulating Materials .....	20
8.1 General .....	20
8.2 Flammability .....	21
8.3 Electrical properties .....	21
8.4 Thermal properties .....	22
8.5 Vulcanized fiber .....	23
8.6 Sealing compounds .....	23
8.7 Fuse enclosures .....	23
9 Enclosure .....	24
9.1 General .....	24
9.2 Male faces and wire terminations .....	26
10 Current-Carrying Parts .....	27
10.1 General .....	27
10.2 Contacts .....	28
11 Grounding and Dead Metal Parts .....	29
12 Terminals .....	30
12.1 General .....	30
12.2 Wire-binding screw terminals .....	31
12.3 Soldering lugs .....	32
12.4 Pressure-wire terminals .....	32
13 Cord Entry and Strain Relief .....	33
14 Spacings .....	34
15 Assembly .....	34
15.1 General .....	34
15.2 Grounding and polarization .....	35
15.3 Mating and interchangeability .....	35
15.4 Fuseholders .....	37
15.5 Switches .....	37

**UL COPYRIGHTED MATERIAL –  
NOT AUTHORIZED FOR FURTHER REPRODUCTION OR  
DISTRIBUTION WITHOUT PERMISSION FROM UL**

## ATTACHMENT PLUGS AND INLETS

16	Insulating Materials	38
17	Enclosure	38
17.1	General	38
17.2	Grip	38
17.3	Face size	38A
18	Current-Carrying Parts	39
19	Grounding and Dead Metal Parts	40
20	Terminals and Leads	42
20.1	Terminals	42
20.2	Leads	42
21	Assembly	43
22	Weatherproof Type	45

## CORD CONNECTORS

23	Enclosure	45
23.1	General	45
23.2	Face size	45
24	Grounding and Dead Metal Parts	49
25	Terminals	49
26	Assembly	49
26.1	General	49
26.2	Outlet separation	50

## RECEPTACLES

27	Insulating Materials	50
28	Enclosure	50
29	Grounding and Dead Metal Parts	51
29.1	General	51
29.2	Flush receptacles	52
30	Terminals and Leads	52
30.1	General	52
30.2	Push-in terminals	53
30.3	Pin-type or insulation-displacement terminals	53
30.4	Open wiring on insulators	53
30.5	Leads	54
31	Assembly	54A
31.1	General	54A
31.2	Flush receptacles	55
31.3	Surface-mount receptacles	56
32	Flush Plates	57
33	Self-Grounding Receptacles	57
34	Isolated-Ground Receptacles	57
35	CO/ALR Type	57
36	AL-CU Type	57
37	Tamper-Resistant	58
37A	Weather-Resistant	58

**UL COPYRIGHTED MATERIAL –  
NOT AUTHORIZED FOR FURTHER REPRODUCTION OR  
DISTRIBUTION WITHOUT PERMISSION FROM UL**

## SELF-CONTAINED RECEPTACLES FOR USE WITHOUT A SEPARATE OUTLET BOX

38	General .....	58
39	Spacings .....	58
40	Insulating Materials .....	58
41	Enclosures .....	59
42	Mounting Means .....	59
43	Frame-Construction Mounting Brackets .....	60
44	Field Replacement .....	60

## CURRENT TAPS

45	General .....	60
----	---------------	----

## FLATIRON AND APPLIANCE PLUGS

46	General .....	61
47	Current-Carrying Parts .....	61
48	Cord Guard .....	61
49	Strain Relief .....	62
50	Female Contacts .....	62
51	Terminals .....	63
52	Spacings .....	63
53	Assembly .....	64

## PERFORMANCE

## GENERAL

54	Representative Devices .....	64
----	------------------------------	----

## ALL DEVICES

55	Comparative Tracking Index Test .....	74
56	Glow Wire Test .....	74
57	High-Current Arc Resistance to Ignition Test .....	74
58	Mold Stress Relief Test .....	76
59	Moisture Absorption Resistance Test .....	77
60	Dielectric Voltage-Withstand Test .....	77
	60.1 Devices for fixed or permanent installation .....	77
	60.2 Cord-connected devices .....	78
61	Accelerated Aging Tests .....	79
	61.1 General .....	79
	61.2 Rubber, EPDM, and TEE compounds .....	79
	61.3 PVC compounds and copolymers .....	79
62	Insulation Resistance Test .....	80
63	Conductor Secureness Test .....	80
64	Tightening Torque Test .....	81

**UL COPYRIGHTED MATERIAL –  
NOT AUTHORIZED FOR FURTHER REPRODUCTION OR  
DISTRIBUTION WITHOUT PERMISSION FROM UL**

## ATTACHMENT PLUGS

## ALL DEVICES

65	General	81
66	Security of Blades Test	81
66.1	General	81
66.2	Self-hinged plugs	82
67	Secureness-Of-Cover Test	82
68	Crushing Test	82
69	Attachment Plug Grip Tests	82
70	Integrity of Assembly Test	86
70.1	General	86
70.2	Self-hinged plugs	86
71	Self-Hinge Flexing Test	87
72	Terminal Temperature Test	87
73	Fuseholder Temperature Test	88

## PIN-TYPE TERMINALS

74	General	89
75	Assembly Test	89
76	Temperature Test	90
77	Strain Relief Test	90
78	Fault Current Test	91
79	Dielectric Voltage-Withstand Test	92

## INLETS

## ALL DEVICES

80	General	92
81	Security of Blades Test	92
82	Terminal Temperature Test	93
83	Fuseholder Temperature Test	94

## PRESSURE-WIRE TERMINALS

84	General	95
85	Strength of Insulating Base Test	96

## CORD CONNECTORS

## ALL DEVICES

86	General	96
87	Retention of Plugs Tests	96
88	Overload Tests	97
88.1	General	97
88.2	Current overload test	99
88.3	Horsepower overload test	99
89	Temperature Test	103
90	Retention of Plugs Test (Repeated)	104

UL COPYRIGHTED MATERIAL –  
 NOT AUTHORIZED FOR FURTHER REPRODUCTION OR  
 DISTRIBUTION WITHOUT PERMISSION FROM UL

- 90.1 General ..... 104
- 90.2 Plug retention ..... 105
- 90.3 Plug Withdrawal ..... 105
- 91 Resistance to Arcing Test ..... 106
- 92 Latching Mechanism Tests ..... 106
  - 92.1 General ..... 106
  - 92.2 Cycling test ..... 106
  - 92.3 Pull test ..... 107
- 93 Fuseholder Temperature Test ..... 108
- 94 Improper Insertion Test ..... 110
- 95 Potential Drop in Grounding Connections Test ..... 111
- 96 Integrity of Assembly Test ..... 111
  - 96.1 General ..... 111
  - 96.2 Self-hinged cord connectors ..... 112
- 97 Self-Hinge Flexing Test ..... 112

PIN-TYPE TERMINALS

- 98 General ..... 112
- 99 Assembly Test ..... 112
- 100 Temperature Test ..... 113
- 101 Strain Relief Test ..... 113
- 102 Fault Current Test ..... 114
- 103 Dielectric Voltage-Withstand Test ..... 115

RECEPTACLES

ALL DEVICES

- 104 General ..... 115
- 105 Retention of Blades Test ..... 115
- 106 Overload Test ..... 119
- 107 Temperature Test ..... 120
- 108 Retention of Blades Test (Repeated) ..... 122
- 109 Resistance to Arcing Test ..... 122A
- 110 Retention of Plugs Test ..... 123
- 111 Overload Test ..... 124
  - 111.1 General ..... 124
  - 111.2 Current overload test ..... 125
  - 111.3 Horsepower overload test ..... 126
- 112 Temperature Test ..... 129
  - 112.1 Contact and terminal temperature ..... 129
  - 112.2 Feed-through terminal temperature ..... 131
- 113 Retention of Plugs Test (Repeated) ..... 132
  - 113.1 General ..... 132
  - 113.2 Plug retention ..... 132
  - 113.3 Plug withdrawal ..... 133
- 114 Resistance to Arcing Test ..... 133
- 115 Fuseholder Temperature Test ..... 134
- 116 Fault Current Test ..... 135
- 117 Terminal Strength Test ..... 136
- 118 Assembly Security Test ..... 140
- 119 Grounding Contact Test ..... 147

UL COPYRIGHTED MATERIAL –  
 NOT AUTHORIZED FOR FURTHER REPRODUCTION OR  
 DISTRIBUTION WITHOUT PERMISSION FROM UL

## PRESSURE-WIRE TERMINALS

120 General .....	153
121 Strength of Insulating Base Test .....	155

## SELF-GROUNDING RECEPTACLES

122 General .....	155
123 Fault Current Test .....	155

## PUSH-IN TERMINALS

124 General .....	158
125 Pullout Test .....	158
126 Temperature Test .....	159
127 Conductor Insertion and Retention Test .....	159
128 Conductor Push-In Test .....	160
129 Terminal Abuse Test .....	161
130 Temperature Test .....	164

## TAMPER-RESISTANT RECEPTACLES

131 General .....	169
132 Probe Test .....	169
133 Impact Test .....	170
133.1 General .....	170
133.2 Ball-pendulum impact .....	170
133.3 Vertical-ball impact .....	173
134 Mechanical Endurance Test .....	175
135 Dielectric Voltage-Withstand Test .....	175

## PIN-TYPE OR INSULATION-DISPLACEMENT TERMINALS

136 General .....	176
137 Heat Cycling and Vibration Tests .....	176
137.1 General .....	176
137.2 Heat cycling test .....	176
137.3 Vibration test .....	177
137.4 Heat cycling test (Continued) .....	177
137.5 Calculations .....	177

## SELF-CONTAINED RECEPTACLES

138 General .....	178
139 Heat Cycling and Vibration Tests .....	178
139.1 General .....	178
139.2 Heat cycling test .....	179
139.3 Vibration test .....	180
139.4 Calculations .....	181
140 Cable Pullout Test .....	181
141 Conductor Pullout Test .....	181
142 Mounting Strength Test .....	182
142.1 General .....	182

**UL COPYRIGHTED MATERIAL –  
NOT AUTHORIZED FOR FURTHER REPRODUCTION OR  
DISTRIBUTION WITHOUT PERMISSION FROM UL**



142.2	Receptacles mounted directly in panels .....	182
142.3	Receptacles supported by mounting brackets .....	182
142.4	Testing .....	182
143	Wall-Mounting Secureness Test .....	183
144	Assembly Security Test .....	183
144.1	General .....	183
144.2	Method A .....	183
144.3	Method B .....	188
145	Field Replacement Test .....	188
146	Fault Current Withstand Test .....	188
147	Knockouts Test .....	189
148	Creep Test .....	189
149	Mold Stress Test .....	189
150	Specimen Flammability Test .....	189
150.1	General .....	189
150.2	Method A .....	190
150.3	Method B .....	190
 <b>CURRENT TAPS</b>		
 <b>ALL DEVICES</b>		
151	General .....	190
152	Contact Security Test .....	190
 <b>FLATIRON AND APPLIANCE PLUGS</b>		
153	General .....	191
154	Millivolt Drop Test .....	191
155	Overload Test .....	191
156	Heating Test .....	192
157	Millivolt Drop Test Repeated .....	192
158	Crushing Test .....	192
159	Mechanical Endurance Test .....	192
160	Accelerated Aging Test .....	195
161	Cord Guard Test .....	195
 <b>RATINGS</b>		
162	Details .....	197
 <b>MARKINGS AND INSTRUCTIONS</b>		
163	General .....	201
163.1	Details .....	201
163.2	Location of markings and instructions .....	201
164	Identification and Marking of Terminals .....	221
164.1	Grounded and grounding .....	221
164.2	Other terminals .....	222
164.3	Removable parts .....	225

**SUPPLEMENT SA - RESERVED FOR FUTURE USE****SUPPLEMENT SB - ENCLOSURE TYPES FOR ENVIRONMENTAL PROTECTION****INTRODUCTION**

SB1 Scope .....	SB1
SB2 Glossary .....	SB1

**CONSTRUCTION**

SB3 General .....	SB2
SB4 Polymeric Enclosures .....	SB3
SB5 Gaskets .....	SB4

**PERFORMANCE**

SB6 General .....	SB4
-------------------	-----

**MARKINGS**

SB7 General .....	SB8
-------------------	-----

**SUPPLEMENT SC - MARINE SHORE POWER INLETS****INTRODUCTION**

SC1 Scope .....	SC1
SC2 Glossary .....	SC1
SC3 General .....	SC1

**CONSTRUCTION**

SC4 General .....	SC2
SC5 Insulating Materials .....	SC4
SC6 Corrosion Resistance .....	SC4

**PERFORMANCE**

SC7 General .....	SC4
SC8 Salt-Spray Test .....	SC4
SC9 Dielectric Voltage-Withstand Test .....	SC5
SC10 Mechanical Strength Test .....	SC5
SC11 Water-Spray Test .....	SC7
SC12 Shock Test .....	SC10

**UL COPYRIGHTED MATERIAL –  
NOT AUTHORIZED FOR FURTHER REPRODUCTION OR  
DISTRIBUTION WITHOUT PERMISSION FROM UL**

**SUPPLEMENT SD - HOSPITAL GRADE DEVICES****INTRODUCTION**

SD1 Scope .....	SD1
-----------------	-----

**CONSTRUCTION**

SD2 General .....	SD1
-------------------	-----

**PERFORMANCE****GENERAL**

SD3 Representative Devices .....	SD2
----------------------------------	-----

**HOSPITAL GRADE ATTACHMENT PLUGS**

SD4 General .....	SD4
SD5 Strain Relief Tests .....	SD4
SD5.1 General .....	SD4
SD5.2 Method A – static pull .....	SD4
SD5.3 Method B – rotary pull .....	SD4
SD5.4 Method C – abrupt removal .....	SD5
SD5.5 Straight attachment plugs .....	SD7
SD5.6 Angle attachment plugs .....	SD7
SD6 Crushing Test .....	SD10
SD7 Impact Resistance Test .....	SD10
SD8 Mechanical Drop Test .....	SD10
SD9 Mold Stress Relief Test .....	SD12

**HOSPITAL GRADE CORD CONNECTORS**

SD10 General .....	SD12
SD11 Grounding Contact Temperature Test .....	SD12A
SD12 Resistance Test .....	SD13
SD13 Grounding Contact Overstress Test .....	SD13
SD14 Plug Connection and Separation Test .....	SD16
SD15 Crushing Test .....	SD16
SD16 Impact Resistance Test .....	SD17
SD17 Mechanical Drop Test .....	SD17
SD18 Mold Stress Relief Test .....	SD19
SD19 Strain Relief Tests .....	SD19
SD19.1 General .....	SD19
SD19.2 Method A – static pull .....	SD20
SD19.3 Method B – rotary pull .....	SD20
SD19.4 Method C – abrupt removal .....	SD20

**UL COPYRIGHTED MATERIAL –  
NOT AUTHORIZED FOR FURTHER REPRODUCTION OR  
DISTRIBUTION WITHOUT PERMISSION FROM UL**

**HOSPITAL GRADE RECEPTACLES**

SD20 General .....SD23  
 SD21 Abrupt Plug Removal Test .....SD23  
 SD22 Grounding Contact Temperature Test .....SD29  
 SD23 Resistance Test .....SD29  
 SD24 Fault Current Test .....SD29  
 SD25 Grounding Contact Overstress Test .....SD30  
 SD26 Terminal Strength Test .....SD32  
 SD27 Assembly Security Test .....SD32  
 SD28 Impact Test .....SD32  
 SD29 Mold Stress Relief Test .....SD32

**MARKINGS**

SD30 General .....SD33

**SUPPLEMENT SE - WEATHER-RESISTANT RECEPTACLES**

**INTRODUCTION**

SE1 Scope .....SE1

**CONSTRUCTION**

SE2 General .....SE2  
 SE3 Insulating Materials .....SE2  
 SE4 Corrosion Resistance .....SE2

**PERFORMANCE**

SE5 General .....SE3  
 SE6 Cold Impact Test .....SE3  
 SE7 Accelerated Aging Test .....SE4  
 SE8 Ultraviolet Light and Water Exposure Test .....SE4

**MARKINGS**

SE9 General .....SE5

**APPENDIX A**

Standards for Components..... A1

**APPENDIX B**

Wiring Device Configurations .....B1

**UL COPYRIGHTED MATERIAL –  
 NOT AUTHORIZED FOR FURTHER REPRODUCTION OR  
 DISTRIBUTION WITHOUT PERMISSION FROM UL**

No Text on This Page

Document Was Downloaded By jianxiong chen For Use By KAI HUA (FOSHAN SHUNDE) ELECTRIC APPLIANCE CO LTD 22381 : 5/8/2008 - 10:34 AM

***UL COPYRIGHTED MATERIAL –  
NOT AUTHORIZED FOR FURTHER REPRODUCTION OR  
DISTRIBUTION WITHOUT PERMISSION FROM UL***

This page intentionally left blank.

## INTRODUCTION

### 1 Scope

1.1 These requirements cover attachment plugs, receptacles, cord connectors, inlets, current taps provided with wiring terminals for flexible cord, and flatiron and appliance plugs - all intended for connection to a branch circuit for use in accordance with the National Electrical Code, ANSI/NFPA 70.

1.2 These requirements do not cover devices rated at more than 200 A or for more than 600 V. See 6.1.

1.3 This standard does not directly apply to, but supplements the following standards:

- a) Devices produced integrally with flexible cord or cable, covered by the Standard for Cord Sets and Power-Supply Cords, UL 817;
- b) Current taps and adapters not provided with wiring terminals for flexible cord covered by the Standard for Current Taps and Adapters, UL 498A;
- c) Devices employing male or female screwshells, covered by the Standard for Lampholders, UL 496;
- d) Devices solely intended for direct connection to the branch circuit in accordance with the National Electrical Code, ANSI/NFPA 70, that are provided with contacts of the pin and sleeve type, covered by the Standard for Plugs, Receptacles and Cable Connectors of the Pin-and-Sleeve Type, UL 1682;
- e) Single and multipole connectors intended for factory assembly to copper or copper alloy conductors or printed wiring boards for use in data, signal, control and power applications within and between electrical equipment, covered by the Standard for Component Connectors for Data, Signal, Control and Power Applications, UL 1977;
- f) Devices intended for installation and use in hazardous (classified) locations in accordance with the National Electrical Code, ANSI/NFPA 70, covered by the Standard for Receptacle-Plug Combinations for Use in Hazardous (Classified) Locations, UL 1010;
- g) Devices intended for use with telecommunications networks, covered by the Standard for Information Technology Equipment – Safety – Part 1: General Requirements, UL 60950-1, or the Standard for Communications Circuit Accessories, UL 1863;
- h) Devices incorporating ground-fault circuit interruption circuitry, covered by the Standard for Ground-Fault Circuit Interrupters, UL 943;
- i) Single- or two-outlet direct plug-in devices incorporating transient voltage surge suppression circuitry, covered by the Standard for Surge Protective Devices, UL 1449;
- j) Single- or two-outlet direct plug-in devices incorporating electromagnetic interference filter circuitry, covered by the Standard for Electromagnetic Interference Filters, UL 1283; or
- k) Cord-connected, relocatable power taps intended only for indoor use as a temporary extension of a grounding alternating-current branch circuit for general use, covered by the Standard for Relocatable Power Taps, UL 1363.

1.3 revised November 16, 2007

**UL COPYRIGHTED MATERIAL –  
NOT AUTHORIZED FOR FURTHER REPRODUCTION OR  
DISTRIBUTION WITHOUT PERMISSION FROM UL**

1.4 This Standard contains the following supplements:

- a) Supplement SA – Reserved for future use.
- b) Supplement SB – Enclosure Types for Environmental Protection
- c) Supplement SC – Marine Shore Power Inlets
- d) Supplement SD – Hospital Grade Devices
- e) Supplement SE – Weather-Resistant Receptacles

1.4 revised May 25, 2007

## 2 Glossary

2.1 For the purposes of this standard, the following definitions apply.

2.2 APPLIANCE COUPLER – A single-outlet, female contact device for attachment to a flexible cord as part of a detachable power-supply cord to be connected to an inlet (motor attachment plug).

2.3 APPLIANCE PLUG – An appliance coupler type of device having a cord guard and a slot configuration specified for use with heating or cooking appliances.

2.4 ATTACHMENT PLUG – A male contact device for the temporary connection of a flexible cord or cable to a receptacle, cord connector, flanged equipment power outlet, or other outlet device.

2.5 BULK SHIPMENT – Any packaging container having more than one receptacle not provided with a unit container.

2.6 CONFIGURATION, LOCKING – A device having a configuration that requires a motion other than a straight push or pull to connect or separate it when used with its mating part.

2.7 CORD CONNECTOR – A female contact device to be wired on flexible cord for use as an extension from an outlet to make a detachable electrical connection to an attachment plug or, as an appliance coupler, to an equipment inlet.

2.8 CURRENT TAP – A device provided with one set of male blades, one or two female outlets, and wiring terminals for flexible cord intended either for factory or field wiring.

2.9 ELECTRICAL (FUNCTIONAL) INSULATION – The insulation necessary for the proper functioning of the product and for basic protection against electrical shock. This includes all parts relied upon to support live parts in place, all internal barriers necessary to maintain spacings, and the outlet face portion of all female devices.

2.10 ENCLOSURE – That part of the device that renders inaccessible all or any parts of the device that may otherwise present a risk of electric shock, retards propagation of flame initiated by electrical disturbances occurring within, or both.

2.11 FIXTURE, EQUIPMENT, OR APPLIANCE OUTLET – A receptacle outlet device for mounting on utilization equipment.

**UL COPYRIGHTED MATERIAL –  
NOT AUTHORIZED FOR FURTHER REPRODUCTION OR  
DISTRIBUTION WITHOUT PERMISSION FROM UL**



2.12 FLATIRON PLUG – An appliance coupler type of a device having a cord guard and a slot configuration specified for use with heating or cooking appliances.

***UL COPYRIGHTED MATERIAL –  
NOT AUTHORIZED FOR FURTHER REPRODUCTION OR  
DISTRIBUTION WITHOUT PERMISSION FROM UL***

No Text on This Page

Document Was Downloaded By jianxiong chen For Use By KAI HUA (FOSHAN SHUNDE) ELECTRIC APPLIANCE CO LTD 22381 : 5/8/2008 - 10:34 AM

***UL COPYRIGHTED MATERIAL –  
NOT AUTHORIZED FOR FURTHER REPRODUCTION OR  
DISTRIBUTION WITHOUT PERMISSION FROM UL***

2.13 GROUNDING-CONDUCTOR PATH – A path between the grounding pin, blade, or contact and the grounding terminal or, if the device has no grounding terminal, the point at which the path makes contact with a part of the metal raceway system, such as a box, box cover, or the raceway itself.

2.14 GROUNDING DEVICE – A device having a 5-15, 5-20, 5-30, 5-50, 6-15, 6-20, 6-30, 6-50, 7-15, 7-20, 7-30, 7-50, 14-15, 14-20, 14-30, 14-50, 14-60, 15-15, 15-20, 15-30, 15-50, 15-60, L5-15, L5-20, L5-30, L6-15, L6-20, L6-30, L7-15, L7-20, L7-30, L8-20, L8-30, L9-20, L9-30, L14-20, L14-30, L15-20, L15-30, L16-20, L16-30, L17-30, L21-20, L21-30, L22-20, L22-30, L23-20, L23-30, TT-R, or ML-2R configuration, the standard configuration illustrated in Figure C3.8, or a nonstandard configuration that employs one blade, pin, or contact exclusively for grounding.

2.15 HOUSING ADAPTER, ANGLE – A part that is intended to replace a portion of an attachment plug or cord connector housing so that the flexible cord exits the strain relief in the same plane as the face of the device.

2.16 HOUSING ADAPTER, SHROUD – A part that is intended to be assembled onto an attachment plug or cord connector to extend the housing beyond the plane of the face of the device.

2.17 INLET – (Motor Attachment Plug) A male contact device to be mounted on utilization equipment to provide an integral blade configuration for the connection of an appliance coupler or cord connector.

2.18 POLARIZED DEVICE – A device constructed for connection to a mating device only in the position that connects related poles of an electrical circuit.

2.19 RECEPTACLE, CLOCK – A flush receptacle having a recessed cord-storage space in an integral flush-device cover plate, commonly used with wall clocks.

2.20 RECEPTACLE, DISPLAY – A flush receptacle provided with a flush device plate or outlet box cover and closure plug or plugs that is intended for use in show window floors and similar locations where the device is not likely to be subjected to scrub water.

2.21 RECEPTACLE, DUPLEX – A receptacle having two contact devices on a single mounting yoke for flush mounting in a plane surface.

2.22 RECEPTACLE, FLUSH – A receptacle which is intended for mounting in or on an outlet box, an outlet-box cover, or a flush-device cover plate for fixed installation on a branch circuit.

2.23 RECEPTACLE, INTERCHANGEABLE or MODULAR – A flush receptacle which is assembled as a single, duplex or triplex outlet in the field from a system of individual outlet modules, mounting yokes, or flush device cover plates.

2.24 RECEPTACLE, ISOLATED GROUND – A receptacle having the grounding terminal electrically isolated from the system ground when installed in a metallic outlet box or raceway system.

2.25 RECEPTACLE, SELF-CONTAINED – A receptacle which includes an enclosure and mounting means intended for flush mounting without the use of a separate flush-device or other outlet box and for connection to one or more nonmetallic sheathed cables containing copper conductors in accordance with National Electrical Code, ANSI/NFPA-70. A self-contained receptacle is primarily used in mobile homes, recreational vehicles, manufactured buildings, and on-site frame construction.

2.26 RECEPTACLE, SELF-GROUNDING – A receptacle which includes a spring clip or other part to provide for electrical continuity between the grounded device yoke and the mounting screw.

**UL COPYRIGHTED MATERIAL –  
NOT AUTHORIZED FOR FURTHER REPRODUCTION OR  
DISTRIBUTION WITHOUT PERMISSION FROM UL**

2.27 RECEPTACLE, SPLIT – A duplex receptacle having line terminals which are capable of being electrically separated.

2.28 RECEPTACLE, SURFACE-MOUNT – A receptacle which includes an enclosure and mounting means intended for surface mounting without the use of a separate outlet box and for connection to exposed nonmetallic cable as permitted by Article 336 of the National Electrical Code, ANSI/NFPA-70.

2.29 RECEPTACLE, TAMPER-RESISTANT – A receptacle which by its construction is intended to limit improper access to its energized contacts and is intended for use in pediatric patient care areas, in accordance with Article 517 of the National Electrical Code, ANSI/NFPA-70.

2.29.1 RECEPTACLE, WEATHER-RESISTANT – A flush-type receptacle which by its construction is intended to provide resistance to the effects of outdoor exposure when installed in accordance with Article 406 of the National Electrical Code, ANSI/NFPA-70.

2.29.1 added May 25, 2007

2.30 SELF-HINGE – A thin molded portion of an enclosure intended to bend during the assembly of a wiring device to a flexible cord.

2.31 TABLE TAP – A cord connector having more than one outlet and intended to rest on a horizontal surface while in use.

2.32 TERMINAL, INSULATION-DISPLACEMENT – A terminal having a contacting member that forces the conductor insulation aside and presses against the side of the conductor to make contact.

2.33 TERMINAL, PIN-TYPE (INSULATION-PIERCING) – A terminal having a contact pin that punctures the conductor insulation to contact the current-carrying conductor.

2.34 TERMINAL, PRESSURE-WIRE – A terminal which establishes a connection between one or more conductors and a terminal plate by means of mechanical pressure without the use of solder. A pressure-wire terminal may be either of the following types:

a) Clamp-Type – A pressure-wire terminal in which the conductor is held under a pressure plate or saddle clamp by one or more screws. This type of terminal may be provided in combination with a wire-binding screw terminal.

b) Setscrew-Type – A pressure-wire terminal in which the pressure is applied by the end of the screw bearing on the conductor, either directly or through a wire-protecting pad.

2.35 TERMINAL, PUSH-IN – A terminal where the stripped end of a conductor is pushed into the terminal and the clamping pressure is maintained by a spring mechanism, without the use of screws.

2.36 TERMINAL, WIRE-BINDING SCREW – A terminal in which the conductor is bent around the screw and is clamped directly under the head of the screw when it is tightened.

2.37 THROUGH-WIRING – A wiring method which permits a group of receptacles to be wired in parallel to a common branch circuit.

2.38 UNIT CONTAINER – The smallest carton, package, or container, in which a receptacle is packaged. A unit container may contain more than one receptacle if they are not intended to be removed from the container for individual sale.

**UL COPYRIGHTED MATERIAL –  
NOT AUTHORIZED FOR FURTHER REPRODUCTION OR  
DISTRIBUTION WITHOUT PERMISSION FROM UL**

### 3 Components

3.1 Except as indicated in 3.2, a component of a product covered by this standard shall comply with the requirements for that component. See Appendix A for a list of standards covering components generally used in the products covered by this standard.

3.2 A component is not required to comply with a specific requirement that:

- a) Involves a feature or characteristic not required in the application of the component in the product covered by this standard, or
- b) Is superseded by a requirement in this standard.

3.3 A component shall be used in accordance with its rating established for the intended conditions of use.

3.4 Specific components are incomplete in construction features or restricted in performance capabilities. Such components are intended for use only under limited conditions, such as certain temperatures not exceeding specified limits, and shall be used only under those specific conditions.

### 4 Units of Measurement

4.1 When a value for measurement is followed by a value in other units in parentheses, the first stated value is the requirement.

### 5 References

5.1 Any undated reference to a code or standard appearing in the requirements of this standard shall be interpreted as referring to the latest edition of that code or standard.

## CONSTRUCTION

ALL DEVICES

### 6 General

6.1 The ratings mentioned throughout this standard including those mentioned in Table 162.1 represent maximum ampacity and maximum operating potential in volts for receptacles and other outlet devices such as cord connectors or current taps.

6.2 A device is considered to be for use on either alternating or direct current unless the rating includes the letters "ac" to restrict the use to alternating current.

*UL COPYRIGHTED MATERIAL –  
NOT AUTHORIZED FOR FURTHER REPRODUCTION OR  
DISTRIBUTION WITHOUT PERMISSION FROM UL*

## 7 Configurations

7.1 The NEMA configurations of various attachment plug and receptacle combinations referenced in this standard are in accordance with Wiring Devices – Dimensional Specifications, ANSI/NEMA WD6, and are included in Appendix B for ease of reference. The figures referenced as Section C3 contain non-NEMA configurations and are found in the Standard for Wiring Device Configurations, UL 1681.

## 8 Insulating Materials

### 8.1 General

8.1.1 All parts that act as the electrical insulation or enclosure of a device shall be made of an insulating material intended for the particular application and shall comply with the requirements in 8.2.1 – 8.4.1. Hard rubber shall not be employed.

*Exception No. 1: The internal insulating systems of components where component requirements exist are not required to comply with the requirements in 8.2.1 – 8.4.1.*

*Exception No. 2: A small part meeting all of the following criteria is not required to comply with the requirements in 8.2.1 – 8.4.1:*

- a) Its volume does not exceed 0.122 cubic inch (2 cm<sup>3</sup>),*
- b) Its maximum dimension does not exceed 1.18 inches (3 cm), and*
- c) Its location is such that it cannot propagate flame from one area to another or act as a bridge between a possible source of ignition and other ignitable parts.*

*Exception No. 3: Fiber or similar material that is equal to or less than 0.010 inch (0.25 mm) thick is not required to comply with the requirements in 8.2.1 – 8.4.1.*

8.1.2 A polymeric material used for electrical insulation or enclosure of live parts shall be fabricated in accordance with the Standard for Polymeric Materials – Fabricated Parts, UL 746D.

*Exception: A polymeric material that is fabricated in the same location where final assembly takes place and where no blending or compounding operations are involved is not required to comply with this requirement.*

## 8.2 Flammability

8.2.1 A polymeric material used for electrical insulation or enclosure of live parts shall have a flame class rating of HB, V-2, V-1, V-0, VTM-2, VTM-1, or VTM-0 in accordance with the requirements of the Standard for Tests for Flammability of Plastic Materials for Parts in Devices and Appliances, UL 94. The flame class rating of the material shall be judged at the minimum thickness employed at the walls and barriers in the device which are critical to the functioning of the insulation or enclosure of the device.

*Exception:* Insulating materials employed in a self-contained receptacle shall instead comply with 40.1.

## 8.3 Electrical properties

8.3.1 A polymeric material used for electrical insulation or enclosure of live parts shall have a Comparative Tracking Index (CTI) rating of 175 V or greater or a performance level class of at least 3.

*Exception No. 1:* A polymeric material used for electrical insulation or enclosure of live parts is not required to comply with this requirement if it complies with the Comparative Tracking Index Test, Section 55.

*Exception No. 2:* A polymeric material used in an enclosure that is separated through air by more than 1/32 inches (0.8 mm) from uninsulated live parts and more than 1/2 inch (12.7 mm) from arcing parts is not required to comply with this requirement.

8.3.2 A polymeric material used for electrical insulation or enclosure of live parts shall have Hot Wire Ignition (HWI) and High-Current Arc Resistance to Ignition (HAI) ratings or performance level classes of at least those shown in Table 8.1 for the flame class rating determined in accordance with 8.2.1. For materials with other than VTM flammability classifications, the HWI and HAI ratings of the material shall be evaluated using the specimen thickness employed in the end product or nominal 1/8 inch (3.2 mm) thickness, whichever is greater.

*Exception No. 1:* A polymeric material used for electrical insulation or enclosure of live parts is not required to comply with the HWI requirements if it complies with the Glow Wire Test, Section 56.

*Exception No. 2:* A polymeric material used for electrical insulation or enclosure of live parts is not required to comply with the HAI requirements if it complies with the High-Current Arc Resistance to Ignition Test, Section 57.

*Exception No. 3:* A polymeric material used in an enclosure of an attachment plug or cord connector which does not enclose live parts, or which encloses insulated live parts where the insulation thickness is greater than 0.028 inches (0.71 mm), is not required to comply with the HWI requirements.

*Exception No. 4:* A polymeric material used in an enclosure that is separated through air by more than 1/32 inches (0.8 mm) from uninsulated live parts and more than 1/2 inch (12.7 mm) from arcing parts is not required to comply with the HWI and HAI requirements.

*Exception No. 5:* Insulating materials employed in a self-contained receptacle shall instead comply with 40.1.

**Table 8.1**  
**Hot wire ignition (HWI) and high-current arc resistance to ignition (HAI) ratings of insulating materials**

Flammability classification <sup>a</sup>	HWI <sup>b,d</sup>		HAI <sup>c,d</sup>	
	Mean ignition time (sec)	PLC	Mean no. of arcs	PLC
V-0, VTM-0	7 and up to 15	4	15 and up to 30	3
V-1, VTM-1	15 and up to 30	3	15 and up to 30	3
V-2, VTM-2	15 and up to 30	3	15 and up to 30	3
HB	30 or more	2	60 or more	1

<sup>a</sup> Flammability classification – Described in the Standard for Tests for Flammability of Plastic Materials for Parts in Devices and Appliances, UL 94.  
<sup>b</sup> Hot Wire Resistance to Ignition – Described in the Standard for Polymeric Materials – Short Term Property Evaluations, UL 746A.  
<sup>c</sup> High-Current Arc Resistance to Ignition – Described in UL 746A.  
<sup>d</sup> Mean ignition time and mean no. of arcs to be used to evaluate Filament Wound Tubing, Industrial Laminates, Vulcanized Fiber, and similar polymeric materials only. All other materials are to be judged using the performance level class values.

## 8.4 Thermal properties

8.4.1 A polymeric material used for electrical insulation or enclosure of live parts shall have the relative thermal index ratings shown in Table 8.2 for the specific application of the insulating material. For materials with other than VTM flammability classifications, the material shall be evaluated using the specimen thickness employed in the end product or nominal 1/8 inch (3.2 mm) thickness, whichever is greater.

*Exception: The following generic materials having readings of 65 or less on the Shore Durometer D scale (when measured for 5 seconds at an ambient temperature of 23.0 ± 2.0°C (73.4 ± 3.6°F)) are acceptable for use at 60°C (140°F) based on their successful completion of the appropriate accelerated aging test described in Accelerated Aging Tests, Section 61:*

- a) Ethylene/Propylene/Diene (EPDM)
- b) Natural Rubber (NR)
- c) Neoprene (Chloroprene Butadiene) Rubber (CBR)
- d) Nitrile Rubber (NBR)
- e) Polyvinyl Chloride (PVC) and its copolymers
- f) Silicone Rubber (SIR)
- g) Styrene (Butadiene) Rubber (SBR)
- h) Thermo Elastomeric [TEE; includes Thermoplastic Elastomers (TPE) and Ethylene Propylene Thermoplastic Rubber (EPTR)]

**UL COPYRIGHTED MATERIAL –  
 NOT AUTHORIZED FOR FURTHER REPRODUCTION OR  
 DISTRIBUTION WITHOUT PERMISSION FROM UL**



**Table 8.2**  
**Minimum relative thermal indices of insulating materials used in insulation and enclosure applications**

Application	Minimum relative thermal index <sup>a</sup> , Degrees C		
	Electrical	Mechanical with impact <sup>b</sup>	Mechanical without impact
Permanently-wired devices (including appliance, fixture and equipment outlets, inlets, and receptacles)	80 <sup>c</sup>	60 <sup>c</sup>	80 <sup>c</sup>
Cord-connected devices (including attachment plugs, cord connectors, and current taps)	60 <sup>c</sup>	60 <sup>c</sup>	60 <sup>c</sup>
<sup>a</sup> Relative Thermal Index – Described in the Standard for Polymeric Materials – Long Term Property Evaluations, UL 746B. <sup>b</sup> For industrial laminates, vulcanized fiber, and similar polymeric materials, the material's minimum RTI for Mechanical shall be evaluated using the values specified for Mechanical Without Impact. <sup>c</sup> For devices containing fuses, the minimum thermal indices shall be the values shown above or the temperature measured on the insulating material during the Fuseholder Temperature Test, whichever is greater. See Sections 73, 83, 93, and 115.			

### 8.5 Vulcanized fiber

8.5.1 Vulcanized fiber is not prohibited from being used for insulating washers, separators, and barriers, but shall not be used as the sole support of live parts.

8.5.2 Vulcanized fiber shall comply with the requirements in 8.2.1 – 8.4.1 and shall be moisture-resistant in accordance with 59.1 and 59.2.

### 8.6 Sealing compounds

8.6.1 A sealing compound shall be insulating, waterproof, and shall not soften at a temperature of 65°C (149°F). The softening point is to be determined using the Test Method for Softening Point by Ring-and-Ball Apparatus, ASTM E28.

8.6.2 Sulphur shall not be employed as a sealing compound.

### 8.7 Fuse enclosures

8.7.1 1 A fuse enclosure shall be of a moisture-resistant material in accordance with 59.1 and 59.2. Fiber and similar absorptive materials shall not be used for the enclosure of a fuse.

8.7.2 A polymeric material classified as Type V-0, V-1, or V-2 is considered as having flammability properties acceptable for use as the enclosure of a fuse.

## 9 Enclosure

### 9.1 General

9.1.1 A device shall have live parts protected against exposure to contact by persons when fully assembled using all essential parts (described in 9.1.5) and installed in the intended manner.

*Exception No. 1: Male blades which are energized only when mated with the corresponding outlet are not required to comply with this requirement.*

*Exception No. 2: Exposed wiring terminals or other live parts enclosed within equipment or within an outlet box when the device is installed in the intended manner are not required to comply with this requirement.*

9.1.2 Accessible dead-metal parts of a grounding device shall be conductively connected to the grounding-conductor path through the device.

*Exception: Accessible dead-metal parts electrically insulated from current-carrying parts are not required to comply with this requirement.*

9.1.3 Accessible dead-metal parts of a nongrounding device shall be electrically insulated from live parts and wiring other than the complete flexible cord so that they are unable to be energized by stray strands, failure of wiring terminals (such as loosening of screws), or damaged or broken wiring. When the stray strand length affects whether a device complies with this requirement, the device shall be marked in accordance with Reference No. 3 to Table 163.1. See 9.1.7.

9.1.4 In order to judge the accessibility of a live or dead-metal part, the device is to be wired and assembled in accordance with the manufacturer's instructions, except that any nonessential parts (described in 9.1.6) that are able to be opened or removed by the user without using a tool are to be opened or removed. The probe shown in Figure 9.1 is to be applied with a force of not more than 3 lbf (13.3 N) to any depth that recessing will permit. The probe is to be rotated, changed in configuration, or angled before, during, and after application to any position that is necessary to examine the device. A live or dead-metal part is determined to be accessible when:

- a) The part is contacted by the probe, or
- b) The part is located in a hole larger than 7.1 mm (9/32 inch) in diameter and recessed less than 4.8 mm (3/16 inch).

**UL COPYRIGHTED MATERIAL –  
NOT AUTHORIZED FOR FURTHER REPRODUCTION OR  
DISTRIBUTION WITHOUT PERMISSION FROM UL**

Figure 9.1  
Articulate probe with web stop

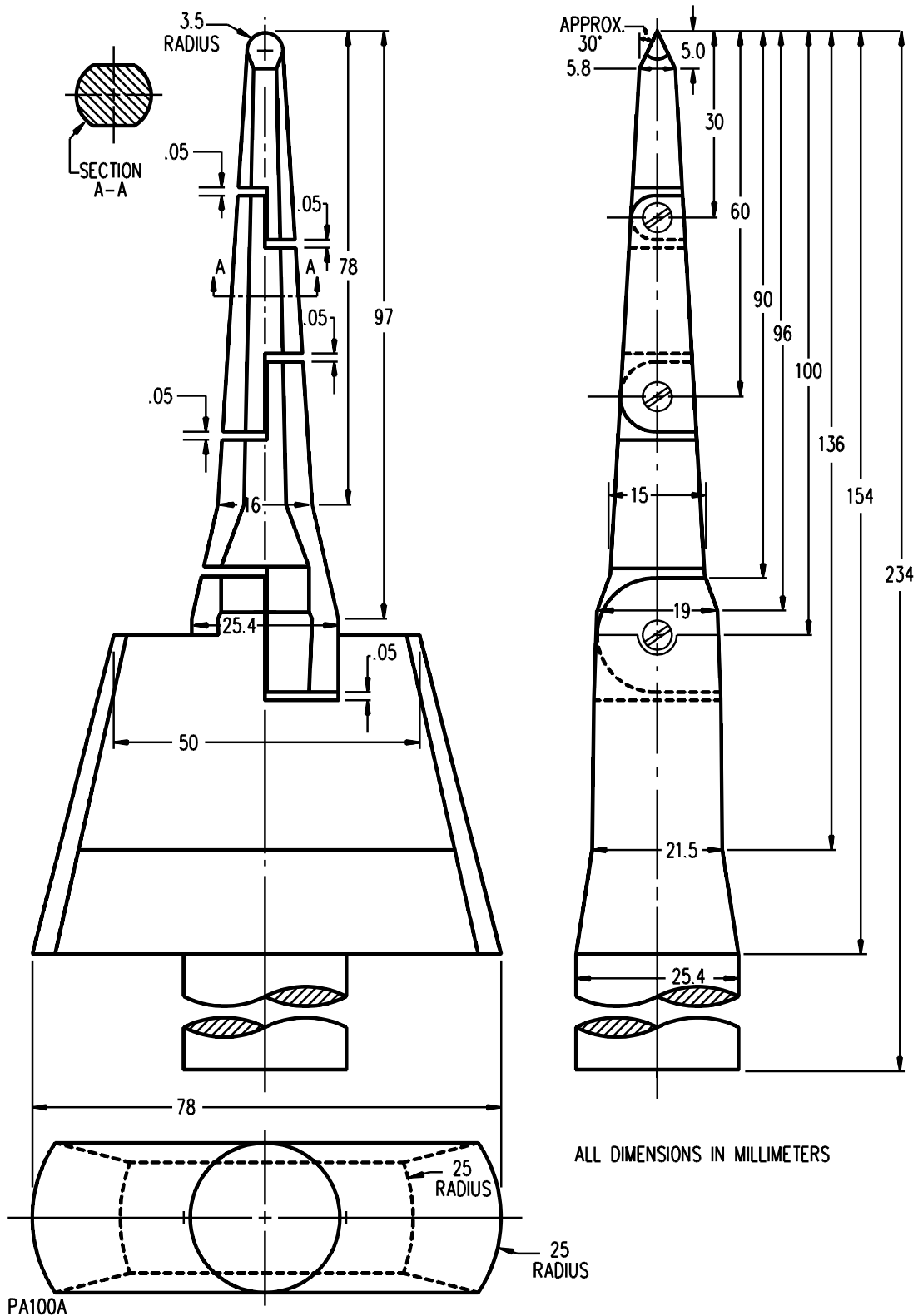

UL COPYRIGHTED MATERIAL –  
NOT AUTHORIZED FOR FURTHER REPRODUCTION OR  
DISTRIBUTION WITHOUT PERMISSION FROM UL

9.1.5 A separable part is considered essential for the operation of the device if it employs a latch or detent or requires use of a tool to remove, and if it performs any of the following functions:

- a) Encloses or completes the enclosure of current-carrying parts other than those on the male face of an attachment plug or current tap;
- b) Encloses or completes the enclosure of the flexible cord from which the jacket has been removed for wiring;
- c) Mechanically secures flexible cord to pin-type terminals; or
- d) Provides for the placement and removal of a fuse.

9.1.6 A separable part (such as an insulating face cover, disc or strain relief clamp) is not considered essential for the operation of the device if it can be removed without the use of a tool or without defeating a latch or detent and if it performs any of the following functions:

- a) Provides strain relief;
- b) Encloses wiring terminals that would otherwise be exposed on the male face of an attachment plug or current tap; or
- c) Provides access to a fuse through the male face of an attachment plug or current tap.

9.1.7 With respect to 9.1.5 (b), the enclosure of a flexible cord is not considered to be complete where two insulated conductors of a parallel-type cord are split apart or where the jacket is removed from the insulated conductors of a jacketed-type cord.

## 9.2 Male faces and wire terminations

9.2.1 The wire terminations of a 15 or 20 A attachment plug or current tap shall be completely enclosed when the device is wired on flexible cord and assembled as intended, using only those parts essential for the operation of the device (dead-front construction). See 9.1.5 and 9.1.6.

9.2.2 An exposed live part on the face of an attachment plug or current tap rated other than 15 or 20 A shall be provided with an insulating disc or face cover that is at least 0.028 inch (0.71 mm) thick and completely covers all exposed live parts. Any unfilled openings on a face cover or disc provided with multiple clearance openings to enable its use with a number of blade arrangements are to be located opposite the anticipated insulating face of the corresponding outlet device.

9.2.3 An insulating disc or face cover intended to be opened or removed to provide access to the wiring terminals shall be mechanically secured after wiring by one or more screws, latches, or detents that cannot be unintentionally opened or removed. A cover that is held in place by only friction without any positive detent action is not considered mechanically secured and is to be subjected to the Secureness-Of-Cover Test described in Section 67.

9.2.4 An insulating disc or face cover shall enclose the wiring terminal compartments with a fit at the periphery that will not permit the entrance of a 0.030 inch diameter (0.76 mm) probe.

*Exception: A notch may be provided in the cover to facilitate removal but only in areas remote from wiring terminals so that unclamped live strands cannot reach the opening. The notch is to comply with all of the following:*

- a) It shall not be deeper than 1/8 inch (3.2 mm) from the periphery;*
- b) It shall not be wider than 3/8 inch (9.5 mm) along the periphery of the cover; and*
- c) It shall not be located within 3/8 inch (9.5 mm) of the binding screw head as measured from the closest point in the notch periphery.*

9.2.5 A device with a separable face cover shall be capable of being properly wired with the maximum size of the heaviest-duty type of flexible cord intended without inhibiting the full seating of the cover. The flexible cord used to determine compliance shall either:

- a) Have an ampacity at least equal to the rating of the device configuration;
- b) Be of the type and size marked on the device; or
- c) Be of the maximum size that can be accommodated by the cord-entrance opening into the device.

9.2.6 An attachment plug or current tap with a separable face cover or disc shall be shipped with the cover attached to the device but not necessarily mechanically secured.

## **10 Current-Carrying Parts**

### **10.1 General**

10.1.1 Iron or steel, plated or unplated, shall not be used for parts that are depended upon to carry current.

*Exception No. 1: Stainless steel may be employed for a part not subject to arcing.*

*Exception No. 2: A steel that is corrosion-resistant (stainless) or is protected against corrosion by cadmium plating, zinc plating, or an equivalent protective coating, may be used for wire-binding nuts and screws if these parts are not depended upon to carry current.*

*Exception No. 3: Iron or steel current-carrying parts employed on a flatiron or appliance plug are not prohibited when protected against corrosion by a metallic plating or other metal coating. See 47.1.*

10.1.2 A current-carrying part shall be restricted from turning relative to the surface on which it is mounted if such turning would adversely affect the performance of the device.

10.1.3 Uninsulated live parts shall be secured in place so that a reduction in the spacings below those required in 14.1 is not likely.

## 10.2 Contacts

10.2.1 Female contacts and associated live parts in the contact opening of an outlet device that can be touched by the probe illustrated in Figure 10.1 shall be recessed from the plane of the opening a distance not less than 1/4 of the maximum straight-line dimension of the opening, or 3/64 inch (1.2 mm), whichever is larger. That plane nearest the face of the device having the minimum opening for the pin or blade clearance is to be used to determine the minimum recess. Bevels, tapers, or other expansions of the opening to the face of the device do not affect the measurement. The probe in Figure 10.1 is to be inserted point first as far as possible in the opening without distorting the perimeter of the opening. The maximum straight-line dimension is the maximum-length straight-line that will fit within the opening at the plane of measurement.

*Exception No. 1: A cord-connector having a 1-15R configuration shall comply with 23.1.1.*

*Exception No. 2: Devices having openings that close upon removal of the attachment plug are not required to comply with this requirement.*

*Exception No. 3: Specific-purpose devices intended only for disconnecting use (see 162.6), are not required to comply with this requirement.*

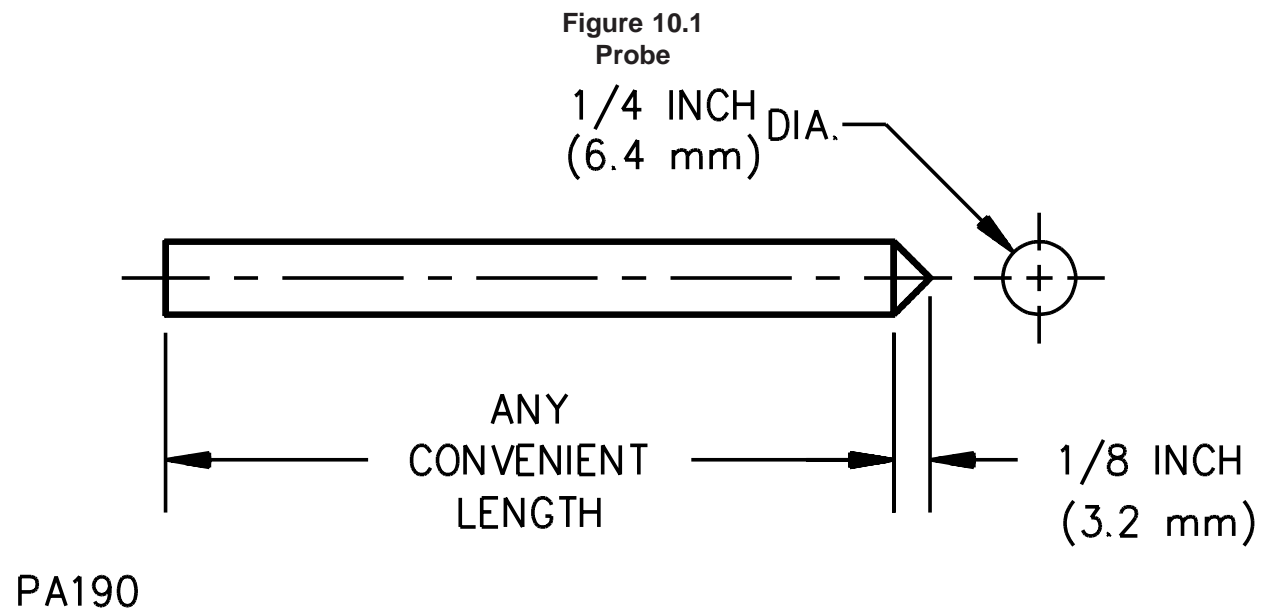

**UL COPYRIGHTED MATERIAL –  
NOT AUTHORIZED FOR FURTHER REPRODUCTION OR  
DISTRIBUTION WITHOUT PERMISSION FROM UL**

## 11 Grounding and Dead Metal Parts

11.1 The following grounding parts shall be of copper or of a copper-base alloy:

- a) The grounding pin, blade, or contact,
- b) The grounding-conductor path through an attachment plug, current tap or cord connector, except for a metal housing or armor, and
- c) The grounding-conductor path through a receptacle up to the strap, yoke, or other mounting means.

*Exception: A rivet, bolt, or clamp that is used to secure parts in the grounding-conductor path, but which is not an essential conductor in the grounding-conductor path, may be of steel or its equivalent.*

11.2 A copper-base-alloy rivet that is used to secure parts in the grounding-conductor path, or that forms a part of the grounding-conductor path, shall not contain less than 80 percent copper.

11.3 The grounding-conductor path connections in a grounding device shall be secured by riveting, bolting, welding, or equivalent means.

*Exception: Another form of connection employed in a cord connector is not prohibited when the connection complies with the requirement in Potential Drop in Grounding Connections Test, Section 95.*

11.4 The grounding pin, blade, or contact, of a grounding device shall be permanently attached to the body of the device.

*Exception: A device in which the grounding member is mounted in soft rubber or similarly flexible material is not precluded by this requirement. The requirement contemplates that the element is to be secured in a manner so that it is not readily removable or movable.*

11.5 Grounding and other dead metal parts shall be secured in place so that a reduction in spacings below those required in 14.1 is not likely.

11.6 The grounding terminal of a grounding device shall be connected to the contact that is intended for use for equipment grounding. For devices having one of the standard grounding configurations, the grounding contact is identified by the letter "G" in the corresponding figure in Wiring Devices – Dimensional Specifications, ANSI/NEMA WD6, and in the Standard for Wiring Device Configurations, UL 1681. The grounding terminal shall be permanently identified in accordance with 164.1.1 in a manner that is readily recognizable during installation. See also 19.1, 24.1, 29.1.2, and Section 164.

11.7 Dead-metal parts of a grounding device shall be conductively connected to the grounding-conductor path through the device. See 9.1.2.

*Exception: Dead-metal parts isolated from current-carrying parts and wiring other than complete flexible cords (see 9.1.7) are not required to comply with this requirement.*

11.8 A conductive connection between a blade, pin, or contact, and an exposed dead-metal part capable of being grounded in service, such as the mounting strap, yoke, or body armor, shall be provided only in a grounding device. A nongrounding device with exposed dead-metal parts shall not be provided with a wiring terminal identified for an equipment grounding conductor. See also 19.4 and 24.2.

*Exception: A nonstandard-configuration device that does not employ a dedicated grounding blade, pin, or contact, but which uses body armor or similar exposed metal parts as an equipment grounding conductor is not prohibited from being provided with an equipment grounding terminal only when the conductive connection between the grounding terminal and the exposed metal parts is obvious to the installer.*

11.9 Dead metal parts of a device for use in nongrounding applications shall be insulated from live parts and wiring other than the complete flexible cord so that stray strands, failure of wiring terminals, or failure of wiring shall not energize accessible dead metal parts. See 9.1.3.

11.10 Iron or steel other than machine screws, washers, nuts, and stainless steel parts shall be protected against corrosion.

*Exception: Parts determined to comply with 31.2.4 and 47.1, are not required to comply with this requirement.*

## 12 Terminals

### 12.1 General

12.1.1 When a device is intended for the connection of conductors, a means shall be provided for connection such as a wire-binding screw or pressure-wire type wiring terminal, or a lead that is factory-assembled by means of soldering, welding, riveting or crimping. A wire-binding screw terminal shall not be used for the connection of circuit wires to a device rated more than 30 A and intended for connection to conductors greater than 10 AWG (5.3 mm<sup>2</sup>).

*Exception: Other forms of construction, such as push-in or insulation-displacement terminals, may be accepted if the mechanical features and current-carrying capability are equivalent to those of the connections mentioned above. See also 20.1.1, 25.1, 30.2.1, and 30.3.1.*

12.1.1 revised November 16, 2007

12.1.2 A terminal provided for the field connection of a grounding conductor shall employ a mechanical clamping means that does not depend upon solder for the connection of the wire.



## 12.2 Wire-binding screw terminals

12.2.1 A wiring terminal that involves a wire-binding screw shall have upturned lugs, or the equivalent, to hold a wire under the head of the screw.

12.2.2 A terminal plate that has a tapped hole for a wire-binding screw shall be of 0.030 inch (0.76 mm) or thicker metal and shall not have fewer than two full threads in the metal. A binding screw that has 32 or more threads per inch (per 25.4 mm) with a terminal plate formed from stock 0.030 inch (0.76 mm) thick, may have the metal extruded at the tapped hole to provide two full threads for the binding screw.

12.2.3 A wire-binding screw shall thread into metal.

12.2.4 The minimum size and maximum number of threads per inch (per 25.4 mm) for a wire-binding screw shall be as indicated in Table 12.1.

**Table 12.1**  
**Sizes of terminal screws**

Rating of device in amperes	Minimum size of screw	Maximum number of threads per inch (per 25.4 mm)
15 or less	6 <sup>a</sup>	36 <sup>c</sup>
20	8 <sup>b</sup>	32 <sup>c</sup>
30	8	32

<sup>a</sup> No. 5-40 screws may be used on devices intended only for other than outlet-box use.

<sup>b</sup> No. 6-36 screws with a 0.296 inch diameter (7.52 mm) or larger head may be used for terminals on attachment plugs and cord connectors. On the device with a 5-20 configuration, the terminal screw that is used for connecting the grounding conductor to the outlet box shall not be smaller than No. 6-36.

<sup>c</sup> No. 8 or larger screws having more than the number of threads per inch (per 25.4 mm) indicated may be used for terminals when the assembly complies with the Tightening Torque Test, Section 64.

12.2.5 A receptacle or inlet rated 30 A or less and employing wire-binding screw terminals for connection to copper branch circuit conductors only, shall comply with the general performance requirements for receptacles, Sections 104 – 119, or the general performance requirements for inlets, Sections 80 – 83, as applicable.

12.2.6 In addition to the requirements in Sections 104 – 119, a receptacle rated 15 or 20 A and employing wire-binding screw terminals for connection to copper and/or aluminum branch circuit conductors shall comply with the CO/ALR Type requirements contained in 35.1.

### 12.3 Soldering lugs

12.3.1 A terminal plate for a soldering lug shall be at least 0.050 in (1.27 mm) thick and shall not have fewer than two full threads in the metal for a terminal screw.

### 12.4 Pressure-wire terminals

12.4.1 A terminal plate for a pressure-wire terminal shall be at least 0.030 inch (0.76 mm) thick and shall not have fewer than two full threads in the metal for a terminal screw.

12.4.2 A pressure-wire terminal intended for the connection of branch circuit conductors to an inlet or receptacle shall be investigated in accordance with Table 12.2.

**Table 12.2**  
**Pressure-wire terminals used in receptacles and inlets**

Use	Current rating	Pressure-wire terminal type	Reference paragraphs
Copper wire only	<30A	Clamp Setscrew	84.2, 120.3 12.4.3, 84.1, 120.2
	≥35A	Clamp Setscrew	12.4.3, 84.1, 120.3 12.4.3, 84.1, 120.3
Copper or aluminum wire	All	All	12.4.3, 36.1, 120.1

12.4.3 The tightening torque for the pressure-wire terminals designated in Table 12.2 shall be specified by the device manufacturer and shall be marked as described in Reference No. 4 of Table 163.2 for inlets and Reference No. 17 of Table 163.4 for receptacles. The specified tightening torque shall not be less than 90 percent of the value employed in the static heating test in the Standard for Equipment Wiring Terminals for Use with Aluminum and/or Copper Conductors, UL 486E, for the maximum wire size corresponding to the ampere rating of the device.

*Exception: A lesser torque value is not prohibited when the connector is investigated in accordance with the Standard for Wire Connectors, UL 486A-486B or UL 486E using the lesser assigned torque value.*

12.4.3 revised November 16, 2007

### 13 Cord Entry and Strain Relief

13.1 A device intended for connection to flexible cord shall be provided with a means of strain relief so that a pull on the flexible cord will not be transmitted directly to the wiring terminations. Acceptability of the strain relief means shall be determined by the test described in Integrity of Assembly Test, Sections 70 or 96.

*Exception: The strain relief provided on a device intended solely for factory assembly to the conductors of a flexible cord shall be subjected to the Integrity of Assembly Test, Sections 70 or 96, but is not required to restrict a pull on the flexible cord from being transmitted directly to the wiring terminations when the conductors are terminated as described in 13.2 (a).*

13.2 A device intended solely for factory assembly to the conductors of a flexible cord is to be connected to the conductors by:

- a) Welding, riveting, crimping, or the equivalent, or
- b) Soldering, when an offset or one or more right-angle bends in the conductor are employed so that a pull on the conductor will not be transmitted directly to the connection.

13.3 A device intended for use with Type SP, SPT, or other parallel-conductor flexible cord, shall be provided with one of the following means for securing the individual conductor insulation:

- a) An integral strain relief, not external to the body of the device,
- b) A means for snubbing, or
- c) Space within the device for a strain-relief knot. If a knot is to be used, all surfaces on which the knot may bear shall be smooth and well-rounded.

13.4 The diameter of a round cord-entry hole or the minor axis of an oblong cord-entry hole provided on a device intended for use on Type SP, SPT, or other parallel-conductor flexible cord shall not be longer than 1/4 inch (6.4 mm).

13.5 A metal-covered device intended for connection to a flexible cord shall be provided with an insulating bushing of porcelain, phenolic or cold-molded composition, or other insulating material with equivalent properties.

*Exception No. 1: Hard fiber is acceptable for the bushing if the fiber is not less than 3/64 inch (1.2 mm) thick, and it is so formed and secured in place that it will not be affected by ordinary conditions of moisture.*

*Exception No. 2: If the metal covering (armor) of a device is not in proximity to the cord-entry hole, and the insulating material of which the plug is made serves as a smooth, well-rounded bushing for a flexible cord, a separate insulating bushing is not required.*

*Exception No. 3: A metal-covered device with a metal cord grip intended specifically for use with a jacketed type of flexible cord, such as Type S or SJ is not required to have an insulating bushing.*

## 14 Spacings

14.1 The spacings maintained through air or over surface shall be a minimum 3/64 inch (1.2 mm) for a device rated 250 V or less, and a minimum 1/8 inch (3.2 mm) for a device rated more than 250 V, between the following:

- a) Uninsulated live parts of opposite polarity;
- b) An uninsulated live part and a dead-metal part that is likely to be grounded or exposed to contact by persons when the device is installed as intended, including a metal surface on which the device is mounted in the intended manner or a metal face plate used with a flush receptacle.

*Exception No. 1: The grounding terminal of a flush receptacle shall instead comply with the spacing requirements in 31.2.1.*

*Exception No. 2: A self-contained receptacle shall instead comply with the spacing requirements in 39.1.*

*Exception No. 3: A dead-metal screw head, rivet, or the like, which is located in a hole not larger than 9/32 inch (7.1 mm) in diameter and recessed not less than 3/16 inch (4.8 mm) is not considered to be exposed to contact by persons after the device is installed in the intended manner.*

14.2 In measuring a spacing, an isolated dead-metal part interposed between live parts of opposite polarity, or between a live part and a grounded or exposed dead-metal part, is considered to reduce the spacing by an amount equal to the dimension of the isolated dead-metal part in the direction of the measurement.

## 15 Assembly

### 15.1 General

15.1.1 A device shall be capable of being readily wired as intended.

15.1.2 Electrical contact shall be reliably maintained at any point at which a connection is made between current-carrying parts.

15.1.3 An outlet device shall have live parts protected against exposure to contact by persons when the outlet is assembled and installed as intended.

15.1.4 When internal connections exist in a multiple-outlet device, similar and corresponding contacts of individual outlets shall be connected together.

15.1.5 A device having female contacts shall be constructed so that a standard attachment plug of the same configuration and with maximum length blades is capable of seating properly without exposure of the blades between the plane of the face of the plug and the plane of the rim of the female contact device.

*Exception: Exposure of the wide side of the blade for a distance of 1/32 inch (0.8 mm) or less (measured along the length of the blade) is acceptable, and exposure of the narrow side of the blade is acceptable if the exposed area is recessed for a distance not shorter than the length (measured along the blade) of the exposed area.*

**UL COPYRIGHTED MATERIAL –  
NOT AUTHORIZED FOR FURTHER REPRODUCTION OR  
DISTRIBUTION WITHOUT PERMISSION FROM UL**

## 15.2 Grounding and polarization

15.2.1 A grounding outlet device shall be so constructed that the grounding member of the corresponding attachment plug cannot be inserted by hand into any outlet slot to touch the live contact.

15.2.2 A device consisting of two or more pieces shall be such that polarization cannot be defeated by improper assembly during installation.

15.2.3 A cord connector or current tap having a 1-15R nonpolarized configuration shall not accommodate an attachment plug having polarized blades to the extent that the wider (polarized) blade can make electrical contact with either outlet device contact. Compliance shall be determined by the test described in Improper Insertion Test, Section 94.

15.2.4 A cord connector or current tap having a 1-15R polarized configuration shall not accommodate an attachment plug having polarized blades in other than the intended orientation to the extent that the wider (polarized) blade can make electrical contact with the contact of the narrower (non-polarized) slot. Compliance shall be determined by the test described in Improper Insertion Test, Section 94.

## 15.3 Mating and interchangeability

15.3.1 A general-use device, including any configuration illustrated in Wiring Devices – Dimensional Specifications, ANSI/NEMA WD6, or the Standard for Wiring Device Configurations, UL 1681, shall be constructed so that electrical continuity between respective and similarly marked terminals is established automatically when the mating plug and outlet device are connected together.

*Exception No. 1: A 2-pole non-polarized device is not required to comply with this requirement*

*Exception No. 2: A special-purpose device for use in equipment where intermixed connections do not increase the risk of fire, electric shock, injury to persons, or damage to equipment, is not required to comply with this requirement.*

15.3.2 An outlet device shall not accommodate an attachment plug other than one that is specifically intended for use with the outlet.

15.3.3 A male or female device that is capable of making a conductive connection with a female or male device of an established general-use design shall be constructed and rated for complete and correct interchangeability with the established design. An established general-use design is considered to include any of the following:

- a) Any of the configurations outlined in Wiring Devices – Dimensional Specifications, ANSI/NEMA WD6;
- b) Any of the configurations outlined in the Standard for Wiring Device Configurations, UL 1681;
- c) Another configuration that is an American National Standard configuration; or
- d) A special-purpose configuration that is acceptable for use in one of the wiring systems that complies with the National Electrical Code, ANSI/NFPA 70.

**UL COPYRIGHTED MATERIAL –  
NOT AUTHORIZED FOR FURTHER REPRODUCTION OR  
DISTRIBUTION WITHOUT PERMISSION FROM UL**

*Exception: A special-purpose receptacle configuration that will not accept any standard general-use plugs shall be permitted to accept a modified general-use plug that will also be accepted by the mating general-use receptacle. (For example, a receptacle for use in a hazardous location that is intended to supply hazardous-location equipment provided with a modified plug that may be used in either an ordinary or hazardous location.)*

15.3.4 A male or female device of an established general-use design shall comply with the dimensions, spacings, and the relative arrangement of blade and contact slots required by one of the following:

- a) Wiring Devices – Dimensional Specifications, ANSI/NEMA WD6;
- b) The Standard for Wiring Device Configurations, UL 1681; or
- c) Other American National Standard.

15.3.5 Attachment plugs, cord connectors, current taps, and receptacles that have different electrical ratings shall not be interchangeable with one another.

*Exception No. 1: A 20-A outlet device is not prohibited from accommodating a 15-A attachment plug for a single and identical voltage rating only.*

*Exception No. 2: A special-purpose configuration that will not mate with a standard general-use configuration shall be permitted to have multiple current and voltage ratings if the device is intended for installation in facilities where it will be serviced only by qualified personnel, and where the configuration will be used on circuits with one of the device's rated currents, voltages and frequencies throughout the facility.*

*Exception No. 3: Plugs, cord connectors, and current taps for use on flexible cords, or that are provided with fuses, that have a lower current rating, as described in Exception No. 1 to 162.1, are not prohibited from mating with corresponding devices with the standard current rating and the identical voltage rating.*

15.3.6 An outlet device having a nongrounding configuration shall not accept a grounding-type attachment plug.

*Exception: The locking grounding device illustrated in Figure C3.8 and marked "Hospital Only" shall be permitted to be interchangeable with other nongrounding general-use devices which are not so marked.*

## 15.4 Fuseholders

15.4.1 An enclosure shall be provided for the fuse or fuses in a device intended to accommodate such components.

15.4.2 A fuse enclosure shall reduce the risk of persons unintentionally contacting uninsulated live parts of the fuse and fuseholder.

15.4.3 A fuse enclosure shall confine the effects of a fuse rupture to the interior of the enclosure.

15.4.4 A device intended for use with a branch-circuit type fuse shall not be capable of accommodating a fuse or fuses that have a rating lower than the maximum rating in volts for the device.

15.4.5 In a fusible device, there shall be provision for a fuse in each ungrounded conductor, but there shall be no provision for a fuse in any other conductor.

15.4.6 The construction of a fusible device that has male pins or blades shall be such that the fuse or fuses will not be removable when the pins or blades are in a receptacle.

*Exception: A fusible attachment plug having a configuration that is not illustrated in Wiring Devices – Dimensional Specifications, ANSI/NEMA WD6, or in the Standard for Wiring Device Configurations, UL 1681, may be provided with a fuse or fuses which is removable when the pins or blades are in a receptacle when the attachment plug is marked in accordance with Reference No. 12 of Table 163.1.*

15.4.7 A fusible outlet device, such as a receptacle or a cord connector, shall not have live parts exposed to contact by persons when a fuse is being removed or replaced.

## 15.5 Switches

15.5.1 A switch provided as a part of a wiring device shall comply with the Standard for General-Use Snap Switches, UL 20. A switch provided as part of a device intended for factory assembly as a component of end-use equipment shall comply either with the Standard for Special-Use Switches, UL 1054, or the Standard for Switches for Appliances, UL 61058-1A.

15.5.1 revised March 15, 2006

## ATTACHMENT PLUGS AND INLETS

### 16 Insulating Materials

16.1 An insulating plate employed for the backing of an inlet shall not be less than 1/32 inch (0.8 mm) thick and shall be moisture-resistant in accordance with 59.1 and 59.2. Phenolic composition or a similar material is acceptable for the insulating plate. Fiber may be employed if it is not less than 1/16 inch (1.6 mm) thick, is impregnated to resist the absorption of moisture in accordance with 59.1 and 59.2, and is not depended upon (by itself) to hold contacts or other live parts in place.

### 17 Enclosure

#### 17.1 General

17.1.1 A general-use attachment plug shall not be provided with more than one cord-outlet hole.

17.1.2 A 2-pole attachment plug shall have a 2-inch (51-mm) or shorter overall length measured from the face of the plug to include any handle grip.

*Exception: A 2-5/8 inch (66.7 mm) (maximum) overall length is acceptable for an attachment plug or current tap if the device:*

- a) Weighs less than 6 oz (170 g),*
- b) Is torsionally balanced about an axis that is perpendicular to the pin face and that is centered between the blades or pins, and*
- c) Has a center of gravity located on this axis no further than 1 inch (25.4 mm) from the pin face.*

17.1.3 A 50-A attachment plug with a molded phenolic shell enclosing the wiring terminals is not acceptable in an application in which the attachment plug is likely to be subject to severe mechanical abuse.

#### 17.2 Grip

17.2.1 An attachment plug having a 1-15P configuration for use on parallel or vacuum cleaner (SV, SVO, SVOO, SVT, SVTO, SVTOO, SVE, SVEO, and SVEOO) type flexible cord shall have a surface that facilitates gripping between the thumb and forefinger or some equivalent finger gripping means independent of the cord to provide for easy insertion and withdrawal from an outlet. See Attachment Plug Grip Tests, Section 69.

**UL COPYRIGHTED MATERIAL –  
NOT AUTHORIZED FOR FURTHER REPRODUCTION OR  
DISTRIBUTION WITHOUT PERMISSION FROM UL**



### 17.3 Face size

17.3.1 The perimeter of the face of an attachment plug having a 1-15P configuration shall encompass an area equal to or larger than that indicated in Figure 17.1.

No Text on This Page

Document Was Downloaded By jianxiong chen For Use By KAI HUA (FOSHAN SHUNDE) ELECTRIC APPLIANCE CO LTD 22381 : 5/8/2008 - 10:34 AM

***UL COPYRIGHTED MATERIAL –  
NOT AUTHORIZED FOR FURTHER REPRODUCTION OR  
DISTRIBUTION WITHOUT PERMISSION FROM UL***

**Figure 17.1**  
**Minimum attachment plug face dimensions**

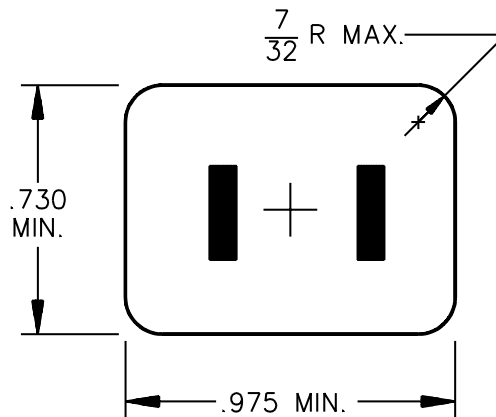

BLADES CENTERED  
 SA1945

inch	7/32	0.730	0.975
mm	5.6	18.5	24.8

**18 Current-Carrying Parts**

18.1 The folded-over blades of 15- or 20-A attachment plugs shall be formed from stock that is 0.028 – 0.032 inches (0.71 – 0.81 mm) thick.

*Exception: Folded-over blades may be formed from stock less than 0.028 inches (0.71 mm) thick provided the stock is not less than 0.020 inch (0.51 mm) thick and both ends of the blade are securely retained within the body of the device, such that the overall thickness is maintained.*

18.2 The profiles of the blades employed in an attachment plug having a 1-15P, 2-15P, 2-20P, 5-15P, 5-20P, 6-15P, or 6-20P configuration shall comply with the dimensional requirements of the Standard for Attachment Plug Blades for Use in Cord Sets and Power-Supply Cords, UL 1659.

**UL COPYRIGHTED MATERIAL –  
 NOT AUTHORIZED FOR FURTHER REPRODUCTION OR  
 DISTRIBUTION WITHOUT PERMISSION FROM UL**

## 19 Grounding and Dead Metal Parts

19.1 The grounding terminal mentioned in 11.6 and its corresponding contact shall be conductively connected to the mounting means (yoke or strap) of a flanged inlet and to the armor of an armored attachment plug.

*Exception: The conductive connection is not required to be provided in a flanged inlet provided all of the following conditions are met:*

- a) *The mounting bracket, yoke, strap, or flange is constructed of an insulating material.*
- b) *The lack of grounding continuity to the mounting means is obvious to the installer.*
- c) *The device is plainly marked in accordance with Reference No. 3 of Table 163.2.*

19.2 For a grounding device, the blade to be used for grounding (G in the figures) shall be longer (see respective figures) than the other blades. For an attachment plug with a nonstandard configuration, the construction of the plug shall be such that, when the plug is inserted into its corresponding receptacle, contact between the grounding blade and the corresponding outlet contact will be made before contact between the other blades and their corresponding contacts.

19.3 A grounding blade or pin of a 15- or 20-A nonlocking type attachment plug shall not contain surface discontinuities that would tend to interfere with insertion or withdrawal from a grounding contact of an outlet device. Abrupt surface transitions such as gaps, steps, offsets, detents, holes or sharp chamfers are specifically prohibited in the following areas shown in Figure 19.1:

- a) The shaft, and
- b) The transition zone between the tip and the shaft which is likely to engage the grounding contact during insertion or withdrawal.

**Figure 19.1**  
**Grounding pin profiles**

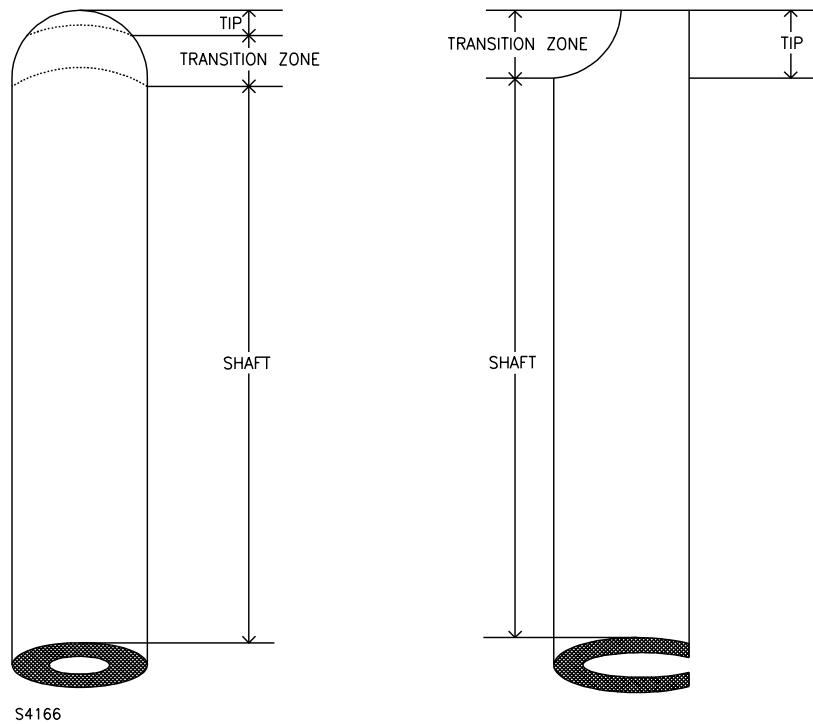

S4166

19.4 For a three- or four-pole attachment plug that requires the connection of a grounding conductor, a wiring terminal for the grounding blade or contact is necessary if the device is intended for use with flexible cord.

*Exception: If the device is intended for use with armored cable, and if the grounding pin or blade is conductively connected to the armor, no wiring terminal is necessary. If on such a device the armor of the attachment plug is conductively connected to the grounding pin or blade (whether or not a wiring terminal is provided), the electrical connection between the armor and the pin or blade is to be readily visible, or the dead metal of the device is to be marked in accordance with Reference No. 3 of Table 163.2.*

**UL COPYRIGHTED MATERIAL –  
NOT AUTHORIZED FOR FURTHER REPRODUCTION OR  
DISTRIBUTION WITHOUT PERMISSION FROM UL**

## 20 Terminals and Leads

### 20.1 Terminals

20.1.1 A pin-type terminal of an attachment plug intended for field assembly on a flexible cord may be accepted for a current-carrying connection only if it complies with the requirements in Sections 75 – 79. An attachment plug with pin-type terminals shall have a 1-15P configuration. See Reference No. 5 to Table 163.1.

20.1.2 If an attachment plug is not provided with wire-binding-screw terminals, and employs a soft-rubber compound molded around the blades and attached conductors, the conductors shall be soldered or welded to the blades or attached by means of pressure-wire connectors.

*Exception: If tinsel cord is employed, the conductors may be secured to the blades under the heads of rivets or by an equivalent means.*

### 20.2 Leads

20.2.1 Integral grounding and circuit conductor leads of an inlet shall be of copper and shall be:

- a) Type RH or TW wire or an equivalent rubber- or thermoplastic-insulated wire for a general-use device and Type SF, SFF, or an equivalent type of wire for a device intended for use in a fixture, and
- b) Not smaller in size than indicated in Table 20.1.

**Table 20.1**  
**Smallest acceptable sizes of inlet leads**

Table 20.1 revised November 16, 2007

Current rating of inlet	Copper circuit leads – AWG (mm <sup>2</sup> )	Copper grounding leads – AWG (mm <sup>2</sup> )
15A	16 <sup>a</sup> or 14 (1.3 <sup>a</sup> or 2.1)	16 <sup>a</sup> or 14 (1.3 <sup>a</sup> or 2.1)
20	12 (3.3)	12 (3.3)
30	10 (5.3)	10 (5.3)
50	6 (13.3)	10 (5.3)
60	4 (21.1)	10 (5.3)

<sup>a</sup> 16 AWG circuit and grounding leads are acceptable only if the inlet is intended for mounting in an appliance.

20.2.2 For an inlet:

- a) An integral grounding pigtail lead shall not be shorter than 6 inches (152 mm), and
- b) Integral circuit leads shall not be shorter than 4 inches (102 mm).

*Exception: For an inlet intended for mounting in an electric lighting fixture or appliance, the length of integral leads is not specified.*

**UL COPYRIGHTED MATERIAL –  
NOT AUTHORIZED FOR FURTHER REPRODUCTION OR  
DISTRIBUTION WITHOUT PERMISSION FROM UL**

## 21 Assembly

21.1 Blades and terminals shall be held securely in place. If they are mounted on a disc of insulating material separate from the rubber compound, the disc shall be:

- a) Of a material acceptable for the mounting of current-carrying parts,
- b) Not less than 1/16 inch (1.6 mm) thick, and
- c) Acceptably secured in the plug.

21.2 Means shall be provided for securely attaching the body of an inlet to the supporting base of an inlet. When assembled, the body shall be restricted from turning with respect to the base.

21.3 A supporting base of an inlet intended for surface mounting shall be provided with no fewer than two holes for mounting screws.

21.4 Live screw heads or nuts on the underside of a base intended for surface mounting shall be spaced 1/2 inch (12.7 mm) or more through air from the mounting surface and staked, upset, or otherwise restricted from loosening.

*Exception No. 1: Live parts that are countersunk not less than 1/8 inch (3.2 mm) and then covered with a sealing compound that complies with 8.6.1 and 8.6.2 are not required to comply with this requirement*

*Exception No. 2: Live parts that are countersunk not less than 1/8 inch (3.2 mm) and then covered with a minimum of 1/16 inch (1.6 mm) thick sealing compound, where the sealing compound complies with 8.6.1 and 8.6.2 and the underside of the supporting base is recessed so that the sealing compound will not contact the surface upon which the receptacle is mounted, are not required to comply with this requirement.*

21.5 An attachment plug intended for connections to radio-antenna, ground, or both shall be such that the blades cannot be inserted to touch the live contacts of a conventional outlet device not intended for use with such a plug. See Figure 21.1 for an example of a radio-antenna plug configuration.

**Figure 21.1**  
**Example of a radio-antenna plug configuration**

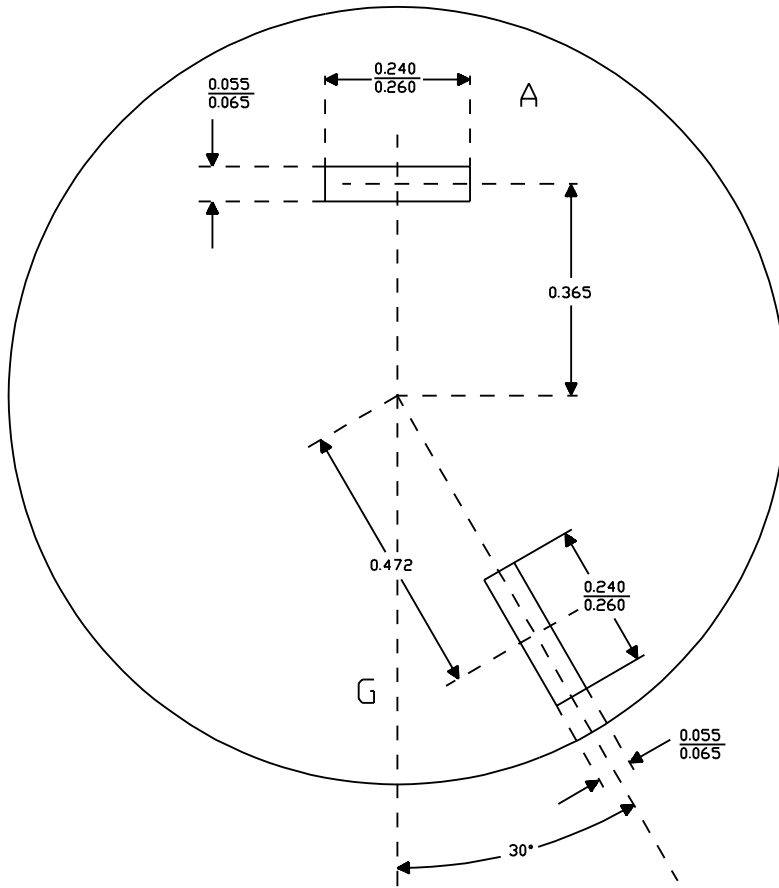

G - GROUND  
 A - AERIAL/ANTENNA

SM1256

inch	0.055	0.065	0.240	0.260	0.365	0.472
mm	1.4	1.7	6.1	6.6	9.3	12.0

**UL COPYRIGHTED MATERIAL –**  
**NOT AUTHORIZED FOR FURTHER REPRODUCTION OR**  
**DISTRIBUTION WITHOUT PERMISSION FROM UL**



## 22 Weatherproof Type

22.1 Fiber and similar absorptive materials shall not be used in a weatherproof attachment plug.

22.2 A lead wire provided as part of a weatherproof attachment plug, and intended to be exposed after installation, shall be:

- a) A stranded RH, RHW, TW, or an equivalent type of wire,
- b) Not smaller than 14 AWG (2.1 mm<sup>2</sup>), and
- c) Not less than 4-1/2 inches (114 mm) long.

22.2 revised November 16, 2007

## CORD CONNECTORS

### 23 Enclosure

#### 23.1 General

23.1.1 A cord connector having a 1-15R configuration intended for use on general-use cord sets employing parallel or vacuum cleaner (SV, SVT, SVO, SVE, SVEO, SVEOO, SVOO, SVTO, and SVTOO) type flexible cord shall have their contacts and other live parts spaced not less than 1/4 inch (6.35 mm) behind the face when measured from the plane of each slot opening through air and over insulating surfaces. The plane of the slot opening is defined as follows:

- a) For slot openings that are bevelled to facilitate the entrance of a plug blade, the plane of the slot opening is that plane nearest the face of the device in which the minor dimensions of the slots are no more than twice the value specified for the 1-15R slot configuration, as shown in Figure 23.1.
- b) For slot openings without bevels, the plane of the slot opening is the plane of the cord connector face.

#### 23.2 Face size

23.2.1 The outlet face of a cord connector having a 5-20R or 6-20R configuration shall obstruct the insertion of an attachment plug having a 6-20P or 5-20P configuration, respectively, to the extent that the indicated devices cannot be mated by deliberate manual force including manipulation to deflect the ground pin to the outside of the face when attempting to insert the line blades. The obstruction shall:

- a) Have the minimum size and shape indicated as the shaded portions of Figure 23.2. The "A" dimension shall be at least 0.531 inch (13.5 mm) for a cord connector molded of a material having a hardness of 90 or greater, and at least 0.625 inch (15.9 mm) for a cord connector molded of a material having a hardness of less than 90, where the material hardness is measured using the "A" scale on a Shore Durometer; and
- b) Be coplanar with the face or recessed by not more than 3/32 inch (2.4 mm).

**UL COPYRIGHTED MATERIAL –  
NOT AUTHORIZED FOR FURTHER REPRODUCTION OR  
DISTRIBUTION WITHOUT PERMISSION FROM UL**

Figure 23.1  
Typical slot cross section (with bevel)

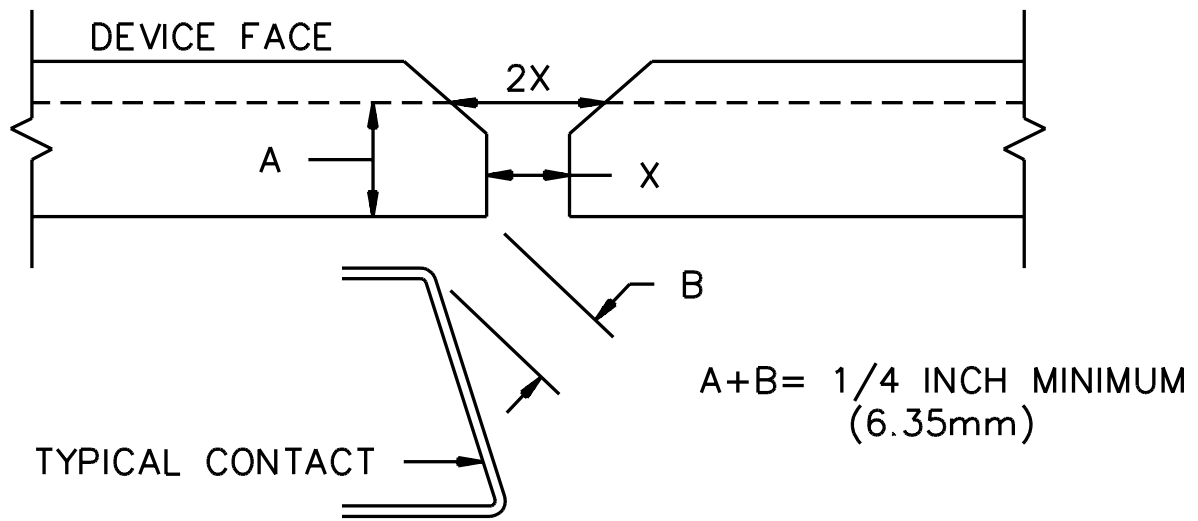

## SA1815

23.2.2 The outlet face of a cord connector having a 1-15R configuration shall have a perimeter that encompasses an area equal to or larger than that indicated in Figure 23.3, and shall obstruct the insertion of an attachment plug having a 5-15P configuration to the extent that the grounding attachment plug cannot be mated by deliberate manual force including manipulation to deflect the ground pin to the outside of the face when attempting to insert the line blades. The obstruction shall:

- Have the minimum size and shape indicated as the shaded portions of Figure 23.2. The "A" dimension shall be at least 0.531 inch (13.5 mm) for a cord connector molded of a material having a hardness of 90 or greater, and at least 0.625 inch (15.9 mm) for a cord connector molded of a material having a hardness of less than 90, where the material hardness is measured using the "A" scale on a Shore Durometer; and
- Be coplanar with the face or recessed by not more than 3/32 inch (2.4 mm).

23.2.2 revised October 23, 2002

UL COPYRIGHTED MATERIAL –  
NOT AUTHORIZED FOR FURTHER REPRODUCTION OR  
DISTRIBUTION WITHOUT PERMISSION FROM UL

Figure 23.2  
 Faces of outlet devices showing locations and minimum dimensions of obstructions

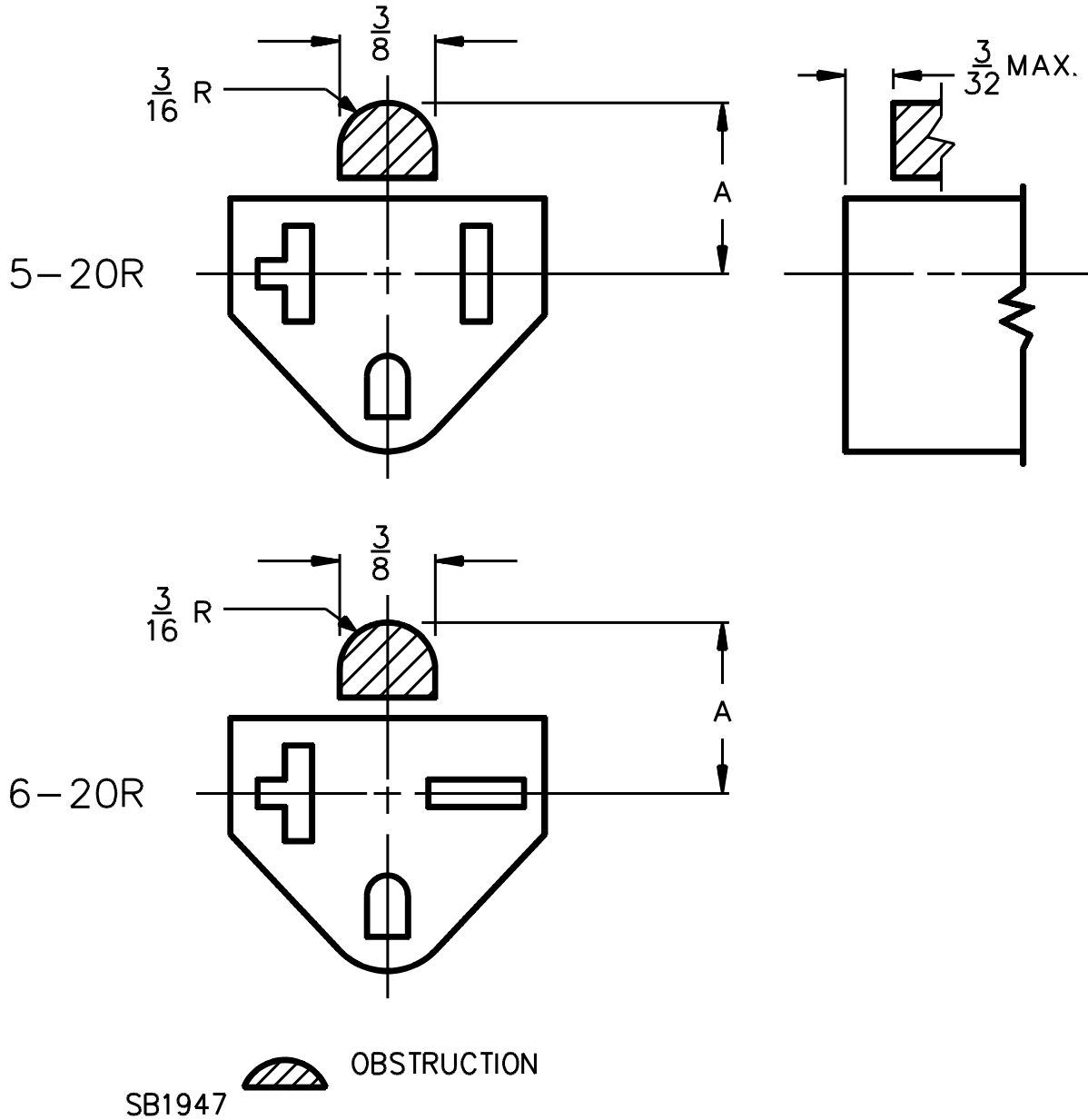

inch	$\frac{3}{32}$	$\frac{3}{16}$	$\frac{3}{8}$
mm	2.4	4.8	9.5

Dimension A inch (mm)	Shore durometer hardness (scale A)
0.625 (15.9)	less than 90
0.531 (13.5)	90 or more

UL COPYRIGHTED MATERIAL –  
 NOT AUTHORIZED FOR FURTHER REPRODUCTION OR  
 DISTRIBUTION WITHOUT PERMISSION FROM UL

Figure 23.3  
Minimum outlet face dimensions

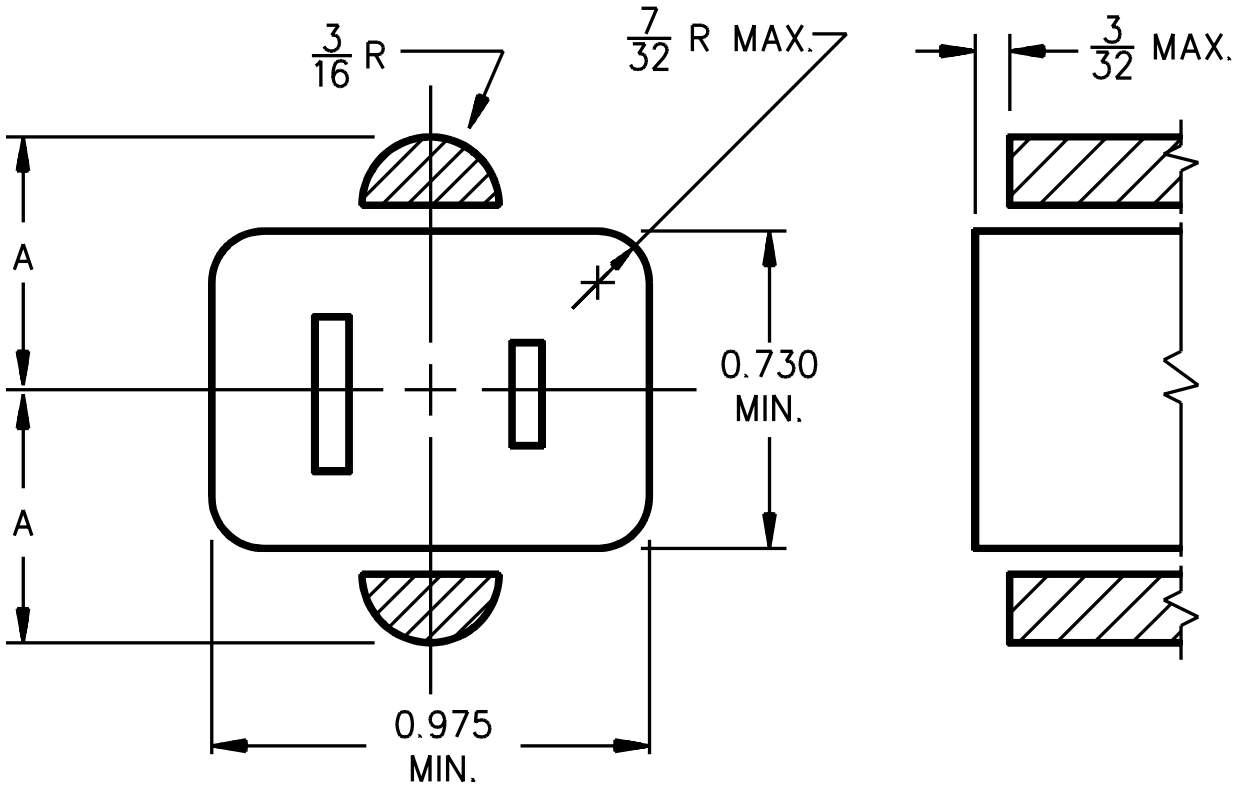

SA1946

CONTACT  
SLOTS CENTERED

inch	3/32	3/16	7/32	0.730	0.975
mm	2.4	4.8	5.6	18.5	24.8

Dimension A inch (mm)	Shore durometer hardness (scale A)
0.625 (15.9)	less than 90
0.531 (13.5)	90 or more

UL COPYRIGHTED MATERIAL –  
NOT AUTHORIZED FOR FURTHER REPRODUCTION OR  
DISTRIBUTION WITHOUT PERMISSION FROM UL

## 24 Grounding and Dead Metal Parts

24.1 The grounding terminal mentioned in 11.6 and 24.2 and its corresponding contact shall be conductively connected to the armor of an armored cord connector.

24.2 For a three- or four-pole cord connector that requires the connection of a grounding conductor, a wiring terminal for the grounding blade or contact is necessary if the device is intended for use with flexible cord.

*Exception: If the device is intended for use with armored cable, and if the grounding contact is conductively connected to the armor, a wiring terminal is not required. If on such a device the armor of the cord connector is conductively connected to the grounding contact (whether or not a wiring terminal is provided), the electrical connection between the armor and the contact is to be readily visible, or the dead metal of the device is to be marked in accordance with Reference No. 11 of Table 163.3.*

24.3 The grounding contact in a grounding-type cord connector shall be located and formed so that the path of electrical continuity to the grounding pin or blade of a mating attachment plug is completed before continuity is established between any other contact and its respective pin or blade on the attachment plug. This grounding path shall be substantial when the attachment plug is properly seated in the cord connector.

## 25 Terminals

25.1 A pin-type terminal of a cord connector intended for field assembly on a flexible cord may be accepted for a current-carrying connection only if it complies with the requirements in Sections 99 – 103. A cord connector with pin-type terminals shall have a 1-15R configuration.

## 26 Assembly

### 26.1 General

26.1.1 In a cord connector, an assembly screw, rivet, or the like that is visible and is electrically connected to any live part shall be located in a hole not larger than 9/32 inch (7.1 mm) in diameter and recessed not less than 3/16 inch (4.8 mm).

26.1.2 When internal connections exist in a multiple-outlet cord connector, similar and corresponding contacts of individual outlets shall be connected together.

26.1.3 A cord connector shall not accommodate an attachment plug other than one that is specifically intended for use with the outlet.

26.1.4 The construction of a cord connector intended for use on a household appliance shall be such that the set of pins described in 50.1 and Table 50.1 cannot, without distortion or forcing, be made to seat properly in the female contacts.

*Exception: A conventional flatiron or appliance plug for use on a household heating appliance is not precluded by this requirement.*

26.1.5 A general-use cord connector including a table tap, shall be constructed with only one hole or breakout for the cord (not for through-cord wiring).

26.1.6 A cord connector shall not be provided with more than three outlets and shall not employ any screw shell outlets.

26.1.7 A table tap shall not be provided with an assembly-screw hole extending through the device from front to back, a mounting-screw hole, or other means by which it can be mounted permanently. If binding-screw terminals are employed, only one set shall be provided, and there shall be means provided for gaining access to them.

26.1.8 A cord connector shall comply with the requirements in 13.1 – 13.5 for strain relief, bushings, and cord grips.

## 26.2 Outlet separation

26.2.1 Cord connectors having two or more outlets of the 1-15R configuration shall provide for the full insertion of attachment plugs in all outlets simultaneously using plugs having the face size indicated in Figure 17.1.

## RECEPTACLES

## 27 Insulating Materials

27.1 A surface-type 50-A receptacle with an enclosure of insulating material is not acceptable for use in an application in which the receptacle is likely to be subject to severe mechanical abuse.

27.2 An insulating plate employed for the backing of a receptacle used to form all or a part of the enclosure shall employ insulating materials that comply with 8.2.1 – 8.4.1. The material shall not be less than 1/32 inch (0.8 mm) thick and shall be moisture-resistant in accordance with 59.1 and 59.2. Fiber may be employed in an insulating plate if it is not less than 1/16 inch (1.6 mm) thick, is impregnated to resist the absorption of moisture in accordance with 59.1 and 59.2 and is not depended upon (by itself) to hold contacts or other live parts in place.

## 28 Enclosure

28.1 If the dimensions of a 1-15R, 2-15R, or 2-20R receptacle face are smaller than shown in Figure 28.1 for the particular configuration used, the receptacle face shall not project more than 3/16 inch (4.8 mm) beyond the flush mounting surface for which it is intended, or less than 3/32 inch (2.4 mm) when the mounting surface is of metal.

**Figure 28.1**  
Dimensional limits for the face of a receptacle

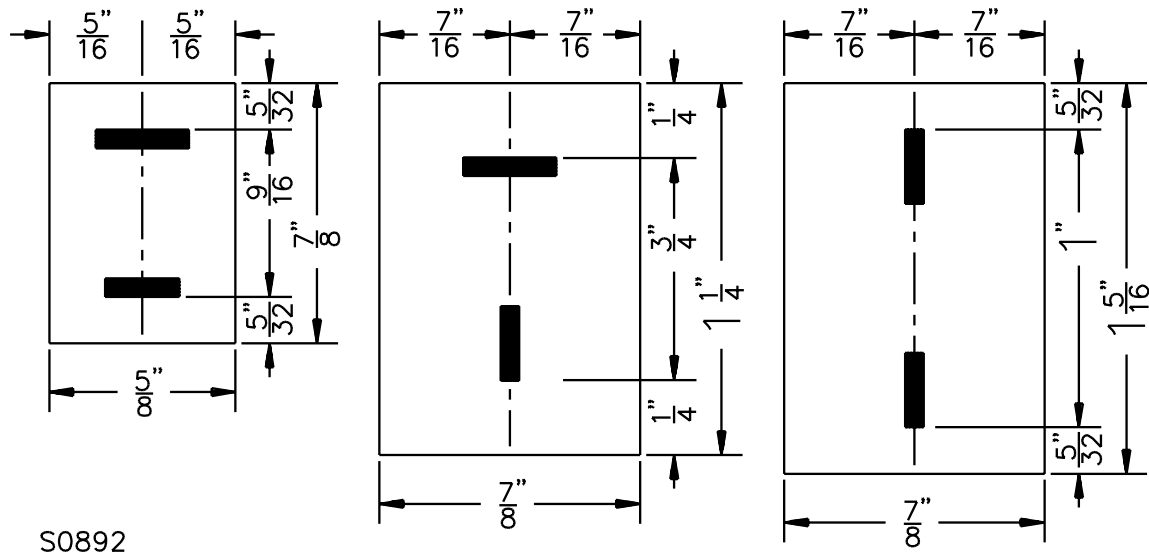

S0892

inch	5/32	1/4	5/16	9/16	5/8	3/4	7/8	1	1-1/4	1-5/16
mm	4.0	6.4	7.9	14.3	15.9	19.1	22.2	25.4	31.8	33.3

**29 Grounding and Dead Metal Parts**

**29.1 General**

29.1.1 The requirement in 11.6 does not preclude the acceptance of a flush receptacle that does not include a grounding terminal provided:

- a) The receptacle can be used only in a metallic wiring system (such as with rigid metal conduit, electrical metallic tubing, surface metal raceway, or the like); and
- b) The connection between the grounding contact and the metal raceway is automatically completed as the receptacle is installed.

29.1.2 The grounding terminal mentioned in 11.6 and its corresponding contact shall be conductively connected to the mounting means (yoke or strap) of a receptacle.

*Exception No. 1: The conductive connection is not required to be provided in an appliance or fixture outlet or a flush receptacle if all the following conditions are met:*

- a) *The mounting means is formed of an insulating material;*
- b) *The lack of grounding continuity to the mounting means is obvious to the installer; and*
- c) *The device is marked in accordance with Reference No. 8 of Table 163.4.*

**UL COPYRIGHTED MATERIAL –  
NOT AUTHORIZED FOR FURTHER REPRODUCTION OR  
DISTRIBUTION WITHOUT PERMISSION FROM UL**

*Exception No. 2: The conductive connection is not required to be provided in an isolated ground receptacle if it is marked in accordance with Reference No. 9 of Table 163.4.*

*Exception No. 3: The conductive connection is not required to be provided in surface-mount receptacles, self-contained receptacles, or any other receptacles for use only with a nonmetallic wiring system (not adaptable to a metallic wiring system).*

29.1.3 The grounding contact in a grounding-type receptacle shall be located and formed so that the path of electrical continuity to the grounding pin or blade of a mating attachment plug is completed before continuity is established between any other contact and its respective pin or blade on the attachment plug. This grounding path shall be substantial when the attachment plug is properly seated in the receptacle.

29.1.4 Only one grounding terminal shall be provided on a grounding-type receptacle.

*Exception No. 1: A surface-mount receptacle of the 5-15R configuration intended for use with nonmetallic-sheathed cable may be provided with two grounding terminals to permit through-wiring of the equipment grounding conductor.*

*Exception No. 2: Each outlet module of an interchangeable or modular receptacle may be provided with its own grounding terminal.*

29.1.5 "Push-In" grounding terminations shall not be used.

## **29.2 Flush receptacles**

29.2.1 All dead-metal parts of a flush receptacle, including the grounding terminal, shall not have sharp edges or points that may be forced against the wiring during installation in an outlet box.

29.2.2 A flush receptacle shall be constructed so that a metal flush plate will be bonded to the metal outlet box or the receptacle grounding terminal when the receptacle is installed as intended.

*Exception: A receptacle with an integral nonmetallic flush plate that cannot be replaced with a metal flush plate is not required to comply with this requirement.*

## **30 Terminals and Leads**

### **30.1 General**

30.1.1 The line wiring terminals of a receptacle intended for mounting in an outlet box shall be located or protected so that, upon installation, they will not be forced against the wiring in the box. See also 29.2.1.

*Exception: Exposed wiring terminals on a receptacle intended solely for mounting in a box intended to be supported by rigid conduit may be located on the back of the receptacle.*

30.1.2 A receptacle shall provide a substantial clearance between each terminal and the metal of a standard box of the type in which it is intended to be installed.



## 30.2 Push-in terminals

30.2.1 A push-in terminal may be accepted for a current-carrying connection in a 5-15R or 6-15R receptacle only if it meets the tests described in Pullout Test, Section 125, and Temperature Test, Section 126, for factory-wired devices and Sections 127 – 130 for field-wired devices.

30.2.2 A flush receptacle having a 5-15R or 6-15R configuration employing "Push-In" line terminations intended for field wiring shall accept a 14 AWG (2.1 mm<sup>2</sup>) solid conductor and shall reject a 12 AWG (3.3 mm<sup>2</sup>) solid conductor. The opening provided for the conductor shall reject a No. 48 drill rod, 0.076 ±0.0003 inch (1.981 ±0.0076 mm) in diameter. The rod is to be applied with 5 lbf (22 N). The receptacle shall be marked in accordance with Reference No. 24 of Table 163.4.

30.2.2 revised November 16, 2007

30.2.3 A "Push-In" terminal shall not be used with stranded wire.

30.2.4 A flush receptacle having a 5-15R or 6-15R configuration employing "Push-In" terminations for field wiring and provided with a means to release the conductors shall not permit entry of a 14 AWG (2.1 mm<sup>2</sup>) or larger solid conductor into any opening in the insulating body provided to engage the release mechanism behind the plane of the mounting means. The wire release means, if provided, shall be subjected to the tests in Temperature Test, Push-In Terminals, Section 130.

30.2.4 revised November 16, 2007

30.2.5 A release mechanism shall be located or guarded so that it cannot be unintentionally actuated during installation. The release mechanism may be guarded by recessing, ribs, barriers, or the like.

## 30.3 Pin-type or insulation-displacement terminals

30.3.1 A pin-type or insulation-displacement terminal of a fixture, equipment, or appliance outlet intended for factory assembly on copper conductors may be accepted for a current-carrying connection only if it complies with the requirements described in the Heat Cycling and Vibration Tests, Section 137.

## 30.4 Open wiring on insulators

30.4.1 Circuit wires entering a receptacle intended for open wiring on insulators:

- a) Shall not be closer than 1/2 inch (12.7 mm) to the surface wired over if the device is rated 250 V less, and
- b) Shall not be closer than 1 inch (25.4 mm) to the surface wired over if the device is rated more than 250 V.

### 30.5 Leads

30.5.1 Integral grounding- and supply-conductor leads of a receptacle shall be of copper and shall be:

- a) Type RH or TW wire or an equivalent rubber- or thermoplastic-insulated wire for a general-use receptacle and Type SF, SFF, or an equivalent type of wire for a fixture type of receptacle, and
- b) Not smaller in size than indicated in Table 30.1.

**Table 30.1**  
**Smallest acceptable sizes of receptacle leads**

Table 30.1 revised November 16, 2007

Current rating of receptacle	Copper supply leads – AWG (mm <sup>2</sup> )	Copper grounding leads – AWG (mm <sup>2</sup> )
15A	16 <sup>a</sup> or 14 (1.3 <sup>a</sup> or 2.1)	16 <sup>a</sup> or 14 (1.3 <sup>a</sup> or 2.1)
20	12 (3.3)	12 (3.3)
30	10 (5.3)	10 (5.3)
50	6 (13.3)	10 (5.3)
60	4 (21.1)	10 (5.3)

<sup>a</sup> 16 AWG supply and grounding leads are acceptable only if the receptacle is intended for mounting in an appliance.

30.5.2 For a general-use receptacle:

- a) An integral grounding pigtail lead shall not be shorter than 6 inches (152 mm), and
- b) Integral supply leads shall not be shorter than 4 inches (102 mm).

*Exception: For an appliance or fixture receptacle outlet, the length of integral leads is not specified.*

## 31 Assembly

### 31.1 General

31.1.1 When internal connections exist in a multiple-outlet receptacle, similar and corresponding contacts of individual outlets shall be connected together.

31.1.2 For a duplex receptacle that includes a break-off jumper between the two halves of a set of unidentified terminals, to provide for a separation that would enable the connection of each outlet to one of the respective ungrounded conductors, and to the grounded conductor of a 3-wire branch circuit, a minimum spacing, based on the maximum potential of the branch circuit (for example, 250 V for 125 V receptacle), is to exist between parts of opposite polarity that are present when the jumper is removed for such use. See 14.1.

*UL COPYRIGHTED MATERIAL –  
NOT AUTHORIZED FOR FURTHER REPRODUCTION OR  
DISTRIBUTION WITHOUT PERMISSION FROM UL*

No Text on This Page

*UL COPYRIGHTED MATERIAL –  
NOT AUTHORIZED FOR FURTHER REPRODUCTION OR  
DISTRIBUTION WITHOUT PERMISSION FROM UL*

31.1.3 A receptacle having a 1-15R configuration that is intended for fixed installation in a wiring system that is in accordance with the National Electrical Code, ANSI/NFPA 70, shall be of the polarized type shown in the 1-15R configuration illustrated in Wiring Devices – Dimensional Specifications, ANSI/NEMA WD6.

31.1.4 A receptacle shall be such that the blades of a radio-attachment plug cannot be inserted to touch the contacts of a receptacle other than one specifically intended for use with such a plug. See Figure 21.1 for an example of a radio-antenna plug configuration.

**31.2 Flush receptacles**

31.2.1 The grounding terminal of a grounding-type flush receptacle shall be spaced at least 1/4 inch (6.4 mm) from any ungrounded live part (associated with other than a white grounded terminal) exposed to contact by a grounding conductor in the outlet box. Live parts accessible from within the cavity of an outlet box are considered exposed to contact by a grounding conductor if they can be contacted by the probe illustrated in Figure 31.1. The spacings shall be measured through air and over both insulating and conductive surfaces with the receptacle wired as intended with the maximum anticipated conductor size. They shall be measured from any point on the grounding terminal that may contact the clamped grounding conductor as in the case of a wire-binding screw terminal, or from any point on the perimeter of an opening to receive a grounding conductor in the case of an enclosed terminal.

**Figure 31.1  
Flat probe**

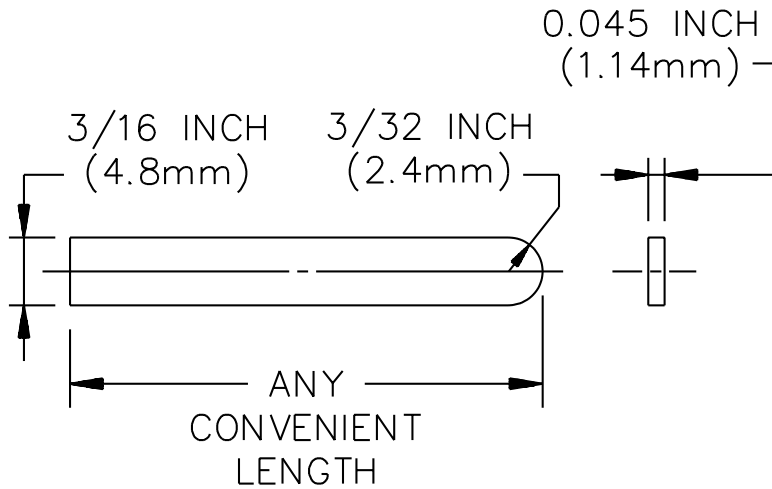

PA215A

inch	0.045	3/32	3/16
mm	1.14	2.4	4.8

31.2.2 A flush receptacle shall be provided with means for mounting in a standard flush-device box or on a standard outlet box cover.

**UL COPYRIGHTED MATERIAL –  
NOT AUTHORIZED FOR FURTHER REPRODUCTION OR  
DISTRIBUTION WITHOUT PERMISSION FROM UL**

31.2.3 A yoke, strap, or mounting ears shall be formed of steel that is a minimum 0.040 inch (1.02 mm) thick.

*Exception No. 1: The minimum thickness at scores or perforations provided so that extension plaster ears may be broken off when not needed is not required to comply with this requirement.*

*Exception No. 2: If nonferrous metal is used, it shall provide mechanical strength and rigidity equal to that of 0.040 inch thick (1.02 mm) steel.*

31.2.4 A steel yoke, strap, or mounting ears shall be protected against corrosion by a copper-plated or oxidized finish.

*Exception: A zinc or cadmium coating not less than 0.00015 inch (0.0038 mm) thick as determined in accordance with the requirements in the Standard for Metallic Outlet Boxes, UL 514A, or other coatings determined to possess equivalent corrosion protection properties are not required to comply with this requirement.*

31.2.5 A screw provided with a receptacle for use in mounting the device to an outlet box or other enclosure shall not project more than 7/8 inch (22.2 mm) beyond the strap or cover and shall have a flat or blunt end. The end of the screw may have thread-cleaning slots or grooves but shall not have any burrs, fins, or other sharp edges that could damage wiring.

### **31.3 Surface-mount receptacles**

31.3.1 In a surface receptacle, an assembly screw, rivet, or the like that is visible and is electrically connected to any live part shall be located in a hole not larger than 9/32 inch (7.1 mm) in diameter and recessed not less than 3/16 inch (4.8 mm).

31.3.2 Means shall be provided for securely attaching the body of a surface-mount receptacle to the supporting base. When assembled, the body shall be restricted from turning with respect to the base.

31.3.3 A supporting base intended for surface mounting shall be provided with no fewer than two holes for mounting screws.

31.3.4 Live screw heads or nuts on the underside of a base intended for surface mounting shall be spaced 1/2 inch (12.7 mm) or more through air from the mounting surface and staked, upset, or otherwise restricted from loosening.

*Exception No. 1: Live parts that are countersunk not less than 1/8 inch (3.2 mm) and then covered with a minimum of 1/8 inch (3.2 mm) thick sealing compound that complies with 8.6.1 and 8.6.2 are not required to comply with this requirement.*

*Exception No. 2: Live parts that are countersunk not less than 1/8 inch (3.2 mm) and then covered with a minimum of 1/16 inch (1.6 mm) thick sealing compound, where the sealing compound complies with 8.6.1 and 8.6.2 and the underside of the supporting base is recessed so that the sealing compound will not contact the surface upon which the receptacle is mounted, are not required to comply with this requirement.*

### 32 Flush Plates

32.1 A flush plate provided as an integral part of a receptacle shall comply with the requirements for flush plates in the Standard for Metallic Outlet Boxes, UL 514A, or the Standard for Nonmetallic Outlet Boxes, Flush-Device Boxes, and Covers, UL 514C.

### 33 Self-Grounding Receptacles

33.1 A self-grounding receptacle shall not be rated greater than 30 A or 150 V to ground and shall comply with the Fault Current Test, Section 123.

### 34 Isolated-Ground Receptacles

34.1 An isolated-ground receptacle shall be identified in accordance with the marking and instruction requirements for isolated-ground receptacles specified in Reference No. 9 of Table 163.4.

### 35 CO/ALR Type

35.1 A receptacle rated 15 or 20 A and which is intended for use with both copper and aluminum conductors shall:

- a) Have only wire-binding screw terminals,
- b) Be intended for mounting in an outlet box,
- c) Be marked in accordance with Reference No. 12 of Table 163.4, and
- d) Meet the performance requirements for receptacles and switches in the Standard for Receptacles and Switches Intended for Use with Aluminum Wire, UL 1567, in addition to the applicable requirements in this standard.

### 36 AL-CU Type

36.1 A receptacle rated 30 A or greater and which is intended for use with both copper and aluminum conductors shall comply with the Temperature Test, Section 112, the general performance requirements for receptacles employing pressure-wire terminals contained in Section 120, and either of the following marking requirements as applicable:

- a) Reference No. 13 of Table 163.4 for conductors rated 60°C (140°F), or
- b) Reference No. 14 of Table 163.4 for conductors rated 75°C (167°F).

### 37 Tamper-Resistant

37.1 A tamper-resistant receptacle shall be marked in accordance with Reference No. 15 of Table 163.4 and comply with the requirements in Sections 132 – 135, and with all other applicable requirements in this standard.

#### 37A Weather-Resistant

37A.1 A weather-resistant receptacle shall comply with the requirements in Supplement SE and with all other applicable requirements in this standard.

37A.1 added May 25, 2007

### SELF-CONTAINED RECEPTACLES FOR USE WITHOUT A SEPARATE OUTLET BOX

### 38 General

38.1 The requirements in Sections 38 – 44 and 138 – 150 are applicable to self-contained general-use receptacles rated 15 and 20 A, 125 and 250 V.

38.2 Self-contained receptacles shall comply with the applicable construction requirements of this standard as modified by the requirements in Sections 39 – 44.

### 39 Spacings

39.1 The spacings maintained between live parts of opposite polarity and between live parts and grounded metal parts shall be at least 1/16 inch (1.59 mm) through air and 1/8 inch (3.18 mm) over surfaces.

### 40 Insulating Materials

40.1 The material used for the support, insulation, and overall enclosure of live parts and cable from which any part of the cable covering has been removed shall be either:

- a) Molded phenolic or urea formaldehyde that complies with 8.2.1, 8.3.1 and 8.3.2, or
- b) Another insulating material determined to be acceptable by means of an appropriate investigation which shall include all of the following requirements:
  - 1) The material shall have a minimum V-2 flammability classification or comply with the requirements of the Specimen Flammability Test, Section 150. The flame class rating of the material shall be judged at the nominal minimum thickness employed at the walls and barriers in the device which are critical to the functioning of the insulation or enclosure of the device.
  - 2) The material shall have a high-ampere arc ignition (HAI) performance level category of 2 or better (at least 30 arcs).
  - 3) The material shall have a hot-wire ignition (HWI) performance level category of 3 or better (at least 15 seconds).
  - 4) The material shall comply with the relative thermal index requirements in 8.4.1.

**UL COPYRIGHTED MATERIAL –  
NOT AUTHORIZED FOR FURTHER REPRODUCTION OR  
DISTRIBUTION WITHOUT PERMISSION FROM UL**



## 41 Enclosures

41.1 All current carrying parts and that part of the cable from which any part of the covering has been removed shall be fully enclosed in the insulating body. This does not preclude:

- a) Slot openings for the receptacle outlet,
- b) Cable openings to be filled in use, or
- c) Assembly joints designed to butt.

41.2 The overall insulating enclosure shall be at least 0.100 inches (2.54 mm) thick.

*Exception No. 1: An enclosure less than 0.100 inches (2.54 mm) thick in the receptacle outlet face or internal barriers that do not form part of the enclosure that is equivalent to an outlet box or flush device cover plate is not prohibited.*

*Exception No. 2: An enclosure less than 0.100 inches (2.54 mm) thick in the areas that form part of the enclosure that is equivalent to an outlet box or flush device cover plate is not prohibited when it complies with the 3/4 inch-flame outlet box flammability test in Non-Metallic Outlet Boxes, Flush-Device Boxes, and Covers, UL 514C.*

*Exception No. 3: Knockouts to be removed for the installation of cable that have a reduced thickness are not prohibited when they comply with the test described in Knockouts Test, Section 147.*

## 42 Mounting Means

42.1 A self-contained receptacle shall be provided with a means for mounting to walls or to frame construction brackets.

42.2 Brackets for mounting a self-contained receptacle shall not have holes located such that a standard flush device may be readily mounted to the bracket.

42.3 Self-contained receptacles shall be constructed so that they cannot readily be mounted in a standard flush device box using the two threaded openings in the box provided for mounting conventional flush devices.

42.4 A mounting bracket for fastening a self-contained receptacle to a structural member in the walls of frame construction shall either be:

- a) Constructed integral with the device, or
- b) Packaged with the device along with installation instructions.

See Frame-Construction Mounting Brackets, Section 43, for requirements for mounting brackets.

### 43 Frame-Construction Mounting Brackets

43.1 Mounting brackets used to fasten self-contained receptacles to studs or joists of frame construction shall comply with all of the following provisions:

- a) The support or mounting means shall be outside the enclosed interior of the insulating body of the self-contained receptacle.
- b) Ferrous material other than stainless steel shall be protected against corrosion with a cadmium or zinc coating having a minimum thickness of 0.0005 inch (0.013 mm) or its equivalent. Cut edges and tapped openings are not required to be protected.
- c) A means shall be provided for the temporary retention of the nonmetallic sheathed cable at the bracket so that the cable will be accessible during installation of the self-contained receptacle. Clips or open hooks integral with the bracket are acceptable.

43.2 The mounting bracket shall also comply with the Mounting Strength Test, Section 142.

### 44 Field Replacement

44.1 Self-contained receptacles marketed as replacement devices shall be capable of installation without the use of special tools.

44.2 Those self-contained receptacles which require replacement with specific devices of similar design shall be marked in accordance with Reference No. 16 of Table 163.4.

## CURRENT TAPS

### 45 General

45.1 In addition to the requirements described in this section, a current tap wired to flexible cord shall comply with the requirements for attachment plugs and cord connectors located elsewhere in this standard and specified in Table 45.1.

**Table 45.1**  
**Construction requirements for current taps**

Construction requirement	Reference
Male face size	17.3.1
Current-carrying parts	18.1, 18.2
Grounding and dead-metal parts	11.6, 19.1, 19.2, 19.3, 24.1, 24.3
Terminals	20.1.1, 20.1.2, 25.1
Assembly	21.1
Recess of live parts	23.1.1
Female face size	23.2.1, 23.2.2

**UL COPYRIGHTED MATERIAL –  
NOT AUTHORIZED FOR FURTHER REPRODUCTION OR  
DISTRIBUTION WITHOUT PERMISSION FROM UL**

45.2 A current tap wired to flexible cord shall not accommodate more than two plugs.

45.3 A current tap shall employ blades on the line side only.

45.4 When internal connections exist in a multiple-outlet current tap, similar and corresponding contacts of individual outlets shall be connected together.

45.5 Current taps having 2 outlets of the 1-15R configuration shall provide for the full insertion of attachment plugs in all outlets simultaneously using plugs having the face size indicated in Figure 17.1.

45.6 When the outlet contacts of a current tap are polarized, the blades shall be polarized and the internal connections between the blades and the contacts shall maintain the polarization.

## FLATIRON AND APPLIANCE PLUGS

### 46 General

46.1 The requirements in Sections 47 – 53 and Sections 153 – 161 are applicable to flatiron and appliance plugs rated 15 and 20 A, 125 and 250 V.

46.2 Flatiron and appliance plugs shall comply with the applicable construction requirements of this Standard as modified by the requirements in Sections 47 – 53.

### 47 Current-Carrying Parts

47.1 Iron or steel current-carrying parts of a flatiron or appliance plug shall be protected against corrosion by a metallic plating or other metal coating. Copper coating and oxidized finishes are not prohibited for use on contacts and their integral screw terminals on flatiron and appliance plugs. Steel is not prohibited for use on contacts and wiring terminals that are integral with the steel contacts.

*Exception: Steel shall not be used for current-carrying parts of a switching mechanism or for wiring terminals in a flatiron or appliance plug that includes a switching mechanism*

### 48 Cord Guard

48.1 A helical wire spring or an equivalently protective part shall be provided at the cord-entrance hole of a flatiron or appliance plug to protect the heater cord from any sharp edges, burrs, or the like that may abrade the cord. The guard shall be held securely in place in the assembled plug. If a separate grommet or bushing is employed, it shall be held securely in place in the guard.

48.2 The guard shall extend from 1-1/2 to 2-1/2 inches (38.1 – 63.5 mm) from the flatiron or appliance plug body. The wireway in the guard shall be large enough in diameter to accommodate the cord without restriction or unnecessary looseness. A smooth metal grommet or an equivalent bushing is acceptable at the free end of a spring guard.

48.3 The guard supplied with a flatiron or appliance plug shall be flexible so as to conform to the motion of the cord in service without producing a sharp bend at or near the point of attachment to the plug. See 161.1.

*Exception: A rigid guard is acceptable if it demonstrates protection equivalent to a flexible cord guard. See 161.1.*

**UL COPYRIGHTED MATERIAL –  
NOT AUTHORIZED FOR FURTHER REPRODUCTION OR  
DISTRIBUTION WITHOUT PERMISSION FROM UL**

## 49 Strain Relief

49.1 The construction of a flatiron or appliance plug shall be such that a force exerted on the flexible cord will not be transmitted to binding-screw terminals or wiring connections. All parts of the plug with which the cord may come in contact shall be smooth and well rounded.

## 50 Female Contacts

50.1 Female contacts shall be held securely, but not necessarily rigidly, within the flatiron or appliance plug body. The configuration and dimensions of the contacts shall be such that the pins detailed in Table 50.1 are accommodated.

50.2 Contacts are not required to be rigidly attached to the flatiron or appliance plug body; a slight amount of floating is acceptable so that the contacts may be somewhat self-aligning with respect to their fit with male pins.

50.3 In a flatiron or appliance plug body, holes for female contacts shall be no larger than necessary to accommodate the male pins.

**Table 50.1**  
**Pins of appliances and flatiron plugs**

Type and rating of plug that accommodates the pins	Configuration of pins			Dimensions of pins	
	Number	Arrangement	Spacing between centers, inch (mm)	Diameter, inch (mm)	Length, inch (mm)
Appliance plug rated 5 A at 250 V and 10 A at 125 V	2	In line	1/2 (12.7)	0.156 ±0.005 (4.0 ±0.13)	9/16 – 5/8 (14.3 – 15.9)
Flatiron plug rated 5 A at 250 V and 10 A at 125 V	2	In line	11/16 (17.5)	0.188 ±0.005 (4.8 ±0.13)	3/4 – 7/8 (19.0 – 22.2)
Jumbo appliance plug rated 10 A at 250 V and 15 A at 125 V	2	In line	1-1/16 (27.0)	0.188 ±0.005 (4.8 ±0.13)	3/4 – 7/8 (19.0 – 22.2)
Reversible plug (for two-heat control) rated 10 A at 250 V and 15 A at 125 V <sup>a</sup>	3	In line	7/8 (22.2)	0.188 ±0.005 (4.8 ±0.13)	3/4 – 7/8 (19.0 – 22.2)
Reversible plug (for two- or three-heat control) rated 10 A at 250 V and 15 A at 125 V <sup>a</sup>	3	One pin at apex of an equilateral triangle	7/8 (22.2)	0.188 ±0.005 (4.8 ±0.13)	3/4 – 7/8 (19.0 – 22.2)

<sup>a</sup> Usually this plug is made without a contact in one of the holes.

**UL COPYRIGHTED MATERIAL –  
NOT AUTHORIZED FOR FURTHER REPRODUCTION OR  
DISTRIBUTION WITHOUT PERMISSION FROM UL**

## 51 Terminals

51.1 A flatiron or appliance plug shall be provided with wiring terminals that will accommodate the following size stranded conductors:

- a) 18 AWG (0.82 mm<sup>2</sup>) if the maximum current rating of the plug is 10 A, and
- b) 16 AWG (1.3 mm<sup>2</sup>) if the rating is 15 A.

*Exception: A plug that is intended for factory assembly to a flexible cord is not required to be provided with wiring terminals.*

51.1 revised November 16, 2007

51.2 A wire-binding screw shall not be smaller than No. 5 (3.2 mm in diameter) with no more than 40 threads per inch (per 25.4 mm).

## 52 Spacings

52.1 There shall be a 3/64 inch (1.2 mm) or larger spacing through air or over the surface between:

- a) Uninsulated live parts of opposite polarity,
- b) An uninsulated live part and a dead-metal part that is likely to be grounded or exposed to contact by persons while the device is being used as intended, and
- c) An uninsulated live part and any exterior surface of the flatiron or appliance plug.

52.2 A dead-metal screw head, rivet, or the like is not considered exposed to contact by persons after the device has been installed in the intended manner if the dead metal is located in a hole not larger in diameter than 9/32 inch (7.1 mm) and is recessed not less than 3/16 inch (4.8 mm).

52.3 In measuring a spacing, an isolated dead-metal part interposed between live parts of opposite polarity or between a live part and a grounded or exposed dead-metal part reduces the spacing by an amount equal to the dimension of the isolated dead-metal part in the direction of the measurement.

### 53 Assembly

53.1 Electrical contact shall be maintained at each connection between current-carrying parts.

53.2 A metal band, guard, assembly plate, or other sheet-metal part on the outside of the molded composition body of a flatiron or appliance plug shall not be closer at any point than 1/16 inch (1.6 mm) to the plane of the end of the plug at which the female contacts are located.

### PERFORMANCE

#### GENERAL

### 54 Representative Devices

54.1 Unless stated otherwise, six representative devices are to be used for each test.

54.2 Attachment plugs are to be subjected to the appropriate tests outlined in Table 54.1.

54.3 Inlets (motor attachment plugs) are to be subjected to the appropriate tests outlined in Table 54.2.

54.4 Cord connectors are to be subject to the appropriate tests outlined in Table 54.3.

54.5 Receptacles are to be subjected to the appropriate tests outlined in Tables 54.4 and 54.5.

54.6 Current taps intended to be wired to flexible cord are to be subjected to the appropriate tests outlined in Table 54.6.

54.7 Flatiron and appliance plugs are to be subjected to the tests outlined in Table 54.7.

**Table 54.1**  
**Summary of tests**  
**General grade attachment plugs**

Table 54.1 revised November 16, 2007

Section	Test Sequences	No. of devices <sup>a</sup>	Details
55	Comparative Tracking Index	5	Materials to be evaluated in accordance with Exception No. 1 to 8.3.1.
56	Glow Wire	3	Materials to be evaluated in accordance with Exception No. 1 to 8.3.2.
57	High-Current Arc Resistance to Ignition	3	Materials to be evaluated in accordance with Exception No.2 to 8.3.2.
60 58 60	Dielectric Voltage-Withstand Mold Stress Relief Dielectric Voltage-Withstand (Repeated)	6	All plugs. Plugs employing thermoplastic material. Plugs subjected to Mold Stress Relief Test.
59	Moisture Absorption Resistance	3	Conducted on vulcanized fibre, fuseholders and insulating backplates. Use insulating material portion of device only.
61	Accelerated Aging	6	Materials to be evaluated in accordance with the Exception to 8.4.1.
66	Security of Blades		Plugs rated 15 A or less and 250 V or less.

UL COPYRIGHTED MATERIAL –  
NOT AUTHORIZED FOR FURTHER REPRODUCTION OR  
DISTRIBUTION WITHOUT PERMISSION FROM UL

Table 54.1 Continued on Next Page

Table 54.1 Continued

Section	Test Sequences	No. of devices <sup>a</sup>	Details
62	Insulation Resistance	6	Conducted on devices molded of rubber or similar materials, or any material containing enough free carbon to render the material grey or black.
63	Conductor Secureness	6	Plugs employing wire leads only.
64	Tightening Torque	6	Plugs with wire-binding screws with pitch greater than that specified in Table 12.1.
66	Security of Blades	6	Plugs rated 15 A or less and 250 V or less that are not subjected to the Accelerated Aging Test.
67	Secureness of Cover	6	Plugs with separable face covers as described in Enclosure, Section 9.
68	Crushing	6	Plugs having a 1-15P, 2-15P, 5-15P, or 6-15P configuration only.
69	Attachment Plug Grip	3	Plugs having a 1-15P configuration for use on parallel or vacuum cleaner type cord as specified in 17.2.1.
70	Integrity of Assembly	6	Not conducted on Hospital Grade plugs or plugs employing pin terminals, strain-relief knots, or certain strain relief constructions. See test description.
71	Self-Hinge Flexing	18	Plugs employing self-hinges in the enclosure.
72	Terminal Temperature	6	Not conducted on plugs with soldered, brazed, or welded cord connections or with wire-binding, pressure-wire or solder terminals.
73	Fuseholder Temperature	6	Plugs with fuseholders only.
75	Assembly	12	Plugs employing pin-type terminals. Number of devices indicated assumes plug accommodates 18 AWG Type SPT-1 wire only. Total number of devices will vary depending upon the number of sizes and types of flexible cord intended for use with the plug. See 76.2.
76	Temperature		
79	Dielectric Voltage-Withstand		
75	Assembly	12	Plugs employing pin-type terminals. Number of devices indicated assumes plug accommodates 18 AWG Type SPT-1 wire only. Total number of devices will vary depending upon the number of sizes and types of flexible cord intended for use with the plug. See 77.2.
77	Strain Relief		
75	Assembly	6	Plugs employing pin-type terminals. Number of devices indicated assumes plug accommodates 18 AWG Type SPT-1 wire only. Total number of devices will vary depending upon the number of sizes and types of flexible cord intended for use with the plug.
78	Fault Current		

<sup>a</sup> A set of representative devices may be used for more than one group of tests if agreeable to all concerned.

**Table 54.2**  
**Summary of tests**  
**Inlets (motor attachment plugs)**

Section	Test sequences	No. of devices <sup>a</sup>	Details
55	Comparative Tracking Index	5	Materials to be evaluated in accordance with Exception No. 1 to 8.3.1.
56	Glow Wire	3	Materials to be evaluated in accordance with Exception No. 1 to 8.3.2.
57	High-Current Arc Resistance to Ignition	3	Materials to be evaluated in accordance with Exception No. 2 to 8.3.2
60	Dielectric Voltage-Withstand	6	All inlets.
58	Mold Stress Relief	6	Inlets employing thermoplastic materials.
60	Dielectric Voltage-Withstand (Repeated)	6	Inlets subjected to Mold Stress Relief Test.
59	Moisture Absorption Resistance	6	Conducted on vulcanized fibre, fuseholders and insulating backplates. Use insulating material portion of device only.
61	Accelerated Aging	6	Materials to be evaluated in accordance with the Exception to 8.4.1.
81	Security of Blades	6	Inlets rated 15 A or less and 250 V or less.
62	Insulation Resistance	6	Conducted on devices molded of rubber or similar materials, or any material containing enough free carbon to render the material grey or black.
63	Conductor Secureness	6	Inlets employing wire leads only.
64	Tightening Torque	6	Inlets with wire-binding screws with pitch greater than that specified in Table 12.1.
81	Security of Blades	6	Inlets rated 15A or less and 250 V or less that are not subjected to the Accelerated Aging Test.
82	Terminal Temperature	6	Not conducted on inlets with soldered, brazed, or welded cord connections or with wire-binding or solder terminals.
83	Fuseholder Temperature	6	Inlets with fuseholders only.
84	Pressure-Wire Terminals – General	6	Inlets with pressure wire terminals only.
85	Strength of Insulating Base	6	Inlets with pressure wire terminals only.

<sup>a</sup> A set of representative devices may be used for more than one groups of tests if agreeable to all concerned.



**Table 54.3**  
**Summary of tests**  
**Cord connectors**

Table 54.3 revised November 16, 2007

Section	Test sequences	No. of devices <sup>a</sup>	Details
55	Comparative Tracking Index	5	Materials to be evaluated in accordance with Exception No. 1 to 8.3.1.
56	Glow Wire	3	Materials to be evaluated in accordance with Exception No. 1 to 8.3.2.
57	High-Current Arc Resistance to Ignition	3	Materials to be evaluated in accordance with Exception No. 2 to 8.3.2.
60 58 60	Dielectric Voltage-Withstand Mold Stress Relief Dielectric Voltage-Withstand (Repeated)	6	All cord connectors. Cord connectors employing thermoplastic materials. Cord Connectors subjected to Mold Stress Relief Test.
59	Moisture Absorption Resistance	3	Conducted on vulcanized fibre, fuseholders and insulating backplates. Use insulating material portion of device only.
61	Accelerated Aging	6	Materials to be evaluated in accordance with the Exception to 8.4.1.
62	Insulation Resistance	6	Conducted on devices molded of rubber or similar materials, or any material containing enough free carbon to render the material grey or black.
63	Conductor Secureness	6	Cord connectors employing wire leads only.
64	Tightening Torque	6	Cord connectors with wire-binding screws with pitch greater than that specified in Table 12.1.
87 88 89 90 91	Retention of Plugs Overload Temperature Retention of Plugs (Repeated) Resistance to Arcing	6 <sup>b</sup>	Cord connectors having a 1-15R, 5-15R, 5-20R, 6-15R, or 6-20R configuration. Test based on current rating.  Cord connectors having a 1-15R, 5-15R, 5-20R, 6-15R, or 6-20R configuration. Not required for devices employing phenolic, urea or melamine in the outlet face.
88	Overload (horsepower)	6	Conducted only on cord connectors with horsepower ratings.
92	Latching Mechanism Tests	12	Cord connectors employing a spring-actuated latching mechanism only.
93	Fuseholder Temperature	6	Cord connectors with fuseholders only.
94	Improper Insertion	12	Cord connectors having a 1-15R configuration only.
95	Potential Drop in Grounding Connections	6	Cord connectors with grounding connections secured by means other than riveting, bolting, welding or equivalent.
96	Integrity of Assembly	6	Not conducted on connectors employing pin terminals, strain relief knots, or certain strain relief constructions. Refer to test description.
97	Self-Hinge Flexing	12	Cord connectors employing self-hinges in the enclosure.

Table 54.3 Continued

Section	Test sequences	No. of devices <sup>a</sup>	Details
99	Assembly	12	Cord connectors employing pin-type terminals. Number of devices indicated assumes connector accommodates 18 AWG Type SPT-1 wire only. Total number of devices will vary depending upon the number of sizes and types of flexible cord intended for use with the connector. See 100.2.
100	Temperature		
103	Dielectric Voltage-Withstand		
99	Assembly	12	Cord connectors employing pin-type terminals. Number of devices indicated assumes connector accommodates 18 AWG Type SPT-1 wire only. Total number of devices will vary depending upon the number of sizes and types of flexible cord intended for use with the connector. See 101.2.
101	Strain Relief		
99	Assembly	6	Cord connectors employing pin-type terminals. Number of devices indicated assumes connector accommodates 18 AWG Type SPT-1 wire only. Total number of devices will vary depending upon the number of sizes and types of flexible cord intended for use with the connector.
102	Fault Current		

<sup>a</sup> A set of representative devices may be used for more than one group of tests if agreeable to all concerned.

<sup>b</sup> For a cord connector with a spring-activated latching mechanism, see 86.2.

**Table 54.4**  
**Summary of tests**  
**Receptacles**

Table 54.4 revised March 15, 2006

Section	Test sequences	No. of devices <sup>a</sup>	Details
55	Comparative Tracking Index	5	Materials to be evaluated in accordance with Exception No. 1 to 8.3.1.
56	Glow Wire	3	Materials to be evaluated in accordance with Exception No. 1 to 8.3.2.
57	High-Current Arc Resistance to Ignition	3	Materials to be evaluated in accordance with Exception No. 2 to 8.3.2.
60	Dielectric Voltage-Withstand	6	All receptacles.
58	Mold Stress Relief		Receptacles employing thermoplastic materials.
60	Dielectric Voltage-Withstand (Repeated)		Receptacles subjected to Mold Stress Relief Test.
59	Moisture Absorption Resistance	3	Conducted on vulcanized fibre, fuseholders and insulating backplates. Use insulating material portion of device only.
61	Accelerated Aging	6	Materials to be evaluated in accordance with the Exception to 8.4.1.
62	Insulation Resistance	6	Conducted on devices molded of rubber or similar materials, or any material containing enough free carbon to render the material grey or black.
63	Conductor Secureness	6	Receptacles employing wire leads only.

UL COPYRIGHTED MATERIAL –  
 NOT AUTHORIZED FOR FURTHER REPRODUCTION OR  
 DISTRIBUTION WITHOUT PERMISSION FROM UL

Table 54.4 Continued on Next Page

Table 54.4 Continued

Section	Test sequences	No. of devices <sup>a</sup>	Details
64	Tightening Torque	6	Receptacles with wire-binding screws with pitch greater than that specified in Table 12.1.
105	Retention of Blades	6	Flush and self-contained receptacles having a 5-15R, 5-20R, 6-15R, or 6-20R configuration. Sections 105 – 109 are superseded by the tests required by Sections 110 – 114 for all other receptacles.
106	Overload		
107	Temperature		
108	Retention of Blades (Repeated)		
109	Resistance to Arcing		
110	Retention of Plugs	6	Receptacles having a 1-15R, 5-15R, 5-20R, 6-15R or 6-20R configuration and not of the flush or self-contained type.
111	Overload		Test based on current rating.
112	Temperature		
113	Retention of Plugs (Repeated)		Receptacles having a 1-15R, 5-15R, 5-20R, 6-15R or 6-20R configuration and not of the flush or self-contained type.
114	Resistance to Arcing		Not required for devices employing phenolic, urea or melamine in the outlet face.
112	Temperature (Terminal)	6	Flush and self-contained receptacles having a 5-15R, 5-20R, 6-15R, or 6-20R configuration. Conducted when a 15 A receptacle is not represented by a 20 A receptacle.
111	Overload (horsepower)	6	Conducted only on receptacles with horsepower ratings and receptacles having the NEMA configurations specified in Table 162.2.
115	Fuseholder Temperature	6	Receptacles with fuseholder only.
116	Fault Current	2	Flush and self-contained receptacles having a 5-15R, 5-20R, 6-15R, or 6-20R configuration.
117	Terminal Strength	3	Flush and self-contained receptacles having a 5-15R, 5-20R, 6-15R, or 6-20R configuration.
118	Assembly Security		
119	Grounding Contact	6	Receptacles having a 5-15R, 5-20R, 6-15R, 6-20R, 7-15R, 14-15R or 15-15R configuration only.
120	Pressure-Wire Terminals (General)	6	Receptacles with pressure-wire terminals only.
121	Strength of Insulating Base and Support	6	Receptacles with pressure-wire terminals only.
123	Fault Current	6	Self-grounding receptacles only.
125	Pullout	6	Factory-wired push-in terminals only.
126	Temperature	6	Factory-wire push-in terminals only.

Table 54.4 Continued

Section	Test sequences	No. of devices <sup>a</sup>	Details
127	Conductor Insertion and Retention	6	Flush and self-contained receptacles having a 5-15R, 5-20R, 6-15R, or 6-20R configuration with push-in terminals with wire release mechanism.
128	Conductor Push-In		
129	Terminal Abuse		
127	Conductor Insertion and Retention	6	Flush and self-contained receptacles having a 5-15R, 5-20R, 6-15R, or 6-20R configuration with push-in terminals without wire release mechanism.
128	Conductor Push-In	6	Flush and self-contained receptacles having a 5-15R, 5-20R, 6-15R, or 6-20R configuration with push-in terminals without wire release mechanism.
129	Terminal Abuse	6	Flush and self-contained receptacles having a 5-15R, 5-20R, 6-15R, or 6-20R configuration with push-in terminals without wire release mechanism.
130	Temperature	8	Flush and self-contained receptacles having a 5-15R, 5-20R, 6-15R, or 6-20R configuration with push-in terminals.
132 133 132 135	Probe Impact Probe (repeated) Dielectric Voltage-Withstand	6	Tamper-resistant receptacles only.
132 134 132 135	Probe Mechanical Endurance Probe (repeated) Dielectric Voltage-Withstand	6	Tamper-resistant receptacles only.
137	Heat Cycling and Vibration	6	Pin-type or insulation-displacement terminals only.
<sup>a</sup> A set of representative devices may be used for more than one test sequence if agreeable to all concerned.			

**Table 54.5**  
**Summary of tests<sup>a</sup>**  
**Self-contained receptacles**

Section	Test sequences	No. of devices <sup>b</sup>	Details
139	Heat Cycling and Vibration	10	Test to be conducted on separate sets of devices rated 15 A and 20 A. Not required if crimp, wire-binding screw or pressure-wire terminal intended for use with copper wire only is used.
140	Cable Pullout	6	Test to be conducted on separate sets of devices rated 15 A and 20 A.
141	Conductor Pullout	3	Test to be conducted on separate sets of devices rated 15 A and 20 A.
142	Mounting Strength	6	Test to be conducted on separate sets of devices if mounted in paneling or mounted to frame construction by bracket.
143	Wall-Mounting Secureness	6	
144	Assembly Security	9	
145	Field Replacement	1	
146	Fault Current Withstand	3	

No Text on This Page

Document Was Downloaded By jianxiong chen For Use By KAI HUA (FOSHAN SHUNDE) ELECTRIC APPLIANCE CO LTD 22381 : 5/8/2008 - 10:34 AM

***UL COPYRIGHTED MATERIAL –  
NOT AUTHORIZED FOR FURTHER REPRODUCTION OR  
DISTRIBUTION WITHOUT PERMISSION FROM UL***

Table 54.5 Continued

Section	Test sequences	No. of devices <sup>b</sup>	Details
147	Knockouts	3	
148	Creep	6	
149	Mold Stress	6	May be combined with the Mold Stress Relief Test in Section 58. See Table 54.4.
150	Specimen Flammability	15	Only conducted on materials having less than a V-2 flame rating. Insulating material specimens measuring 5.0 in by 0.5 in (127 by 12.7 mm) are used for this test.

<sup>a</sup> To be conducted in addition to any applicable tests specified in Table 54.4.

<sup>b</sup> A set of representative devices may be used for more than one test sequence if agreeable to all concerned.

**Table 54.6**  
**Summary of tests**  
**Current taps**

Table 54.6 revised November 16, 2007

Section	Test sequence	No. of devices <sup>a</sup>	Details
55	Comparative Tracking Index	5	Materials to be evaluated in accordance with Exception No. 1 to 8.3.1.
56	Glow Wire	3	Materials to be evaluated in accordance with Exception No. 1 to 8.3.2.
57	High-Current Arc Resistance to Ignition	3	Materials to be evaluated in accordance with Exception No. 2 to 8.3.2.
60	Dielectric Voltage-Withstand	6	All devices
58	Mold Stress Relief		Devices employing thermoplastic materials.
60	Dielectric Voltage-Withstand (Repeated)		Devices subjected to Mold Stress Relief Test.
59	Moisture Absorption Resistance	3	Conducted on vulcanized fibre, fuseholders and insulating backplates. Use insulating material portion of device only.
61	Accelerated Aging	6	Materials to be evaluated in accordance with the Exception to 8.4.1.
66	Security of Blades		Devices rated 15 A or less and 250 V or less.
62	Insulation Resistance	6	Conducted on devices molded of rubber or similar materials, or any material containing enough free carbon to render the material grey or black.
63	Conductor Secureness	6	Devices employing wire leads only.
64	Tightening Torque	6	Devices with wire-binding screws with pitch greater than that specified in Table 12.1.
66	Security of Blades	6	Devices rated 15 A or less and 250 V or less that are not subjected to the Accelerated Aging Test.
67	Secureness of Cover	6	Devices for wiring onto flexible cord that employ separable face covers as described in Enclosure, Section 9.
70	Integrity of Assembly	6	Devices for wiring onto flexible cord only. Not conducted on devices employing pin terminals, strain-relief knots, or certain strain relief constructions. Refer to test description.
71	Self-Hinge Flexing	18	Devices employing self-hinges in the enclosure only.
152	Contact Security	6	Devices having 1-15P configuration blades only.

UL COPYRIGHTED MATERIAL –  
 NOT AUTHORIZED FOR FURTHER REPRODUCTION OR  
 DISTRIBUTION WITHOUT PERMISSION FROM UL

Table 54.6 Continued on Next Page

Table 54.6 Continued

Section	Test sequence	No. of devices <sup>a</sup>	Details
87	Retention of Plugs	6	Devices having a 1-15R, 5-15R, 5-20R, 6-15R or 6-20R configuration.
88	Overload		
89	Temperature		
90	Retention of Plugs (Repeated)		Devices having a 1-15R, 5-15R, 5-20R, 6-15R or 6-20R configuration.
91	Resistance to Arcing		Not required for devices employing phenolic, urea, or melamine in the outlet face.
93	Fuseholder Temperature	6	Devices with fuseholders only.
94	Improper Insertion	12	Devices with a 1-15R outlet face configuration only.
99	Assembly	12	Devices employing pin-type terminals. Number of devices indicated assumes device accommodates 18 AWG Type SPT-1 wire only. Total number of devices will vary depending upon the number of sizes and types of flexible cord intended for use with the device. See 100.2.
100	Temperature		
103	Dielectric Voltage-Withstand		
99	Assembly	12	Devices employing pin-type terminals. Number of devices indicated assumes device accommodates 18 AWG Type SPT-1 wire only. Total number of devices will vary depending upon the number of sizes and types of flexible cord intended for use with the device. See 101.2.
101	Strain Relief		
99	Assembly	6	Devices employing pin-type terminals. Number of devices indicated assumes device accommodates 18 AWG Type SPT-1 wire only. Total number of devices will vary depending upon the number of sizes and types of flexible cord intended for use with the device.
102	Fault Current		

<sup>a</sup> A set of representative devices may be used for more than one group of tests if agreeable to all concerned.



**Table 54.7**  
**Summary of tests**  
**Flatiron and appliance plugs**

Section	Test sequences	No. of devices <sup>a</sup>	Details
55	Comparative Tracking Index	5	Materials to be evaluated in accordance with Exception No. 1 to 8.3.1.
56	Glow Wire	3	Materials to be evaluated in accordance with Exception No. 1 to 8.3.2.
57	High-Current Arc Resistance to Ignition	3	Materials to be evaluated in accordance with Exception No. 2 to 8.3.2.
60	Dielectric Voltage-Withstand	6	All plugs.
58	Mold Stress Relief		Plugs employing thermoplastic materials.
60	Dielectric Voltage-Withstand (Repeated)		Plugs subjected to Mold Stress Relief Test.
59	Moisture Absorption Resistance	3	Conducted on vulcanized fibre, fuseholders and insulating backplates. Use insulating material portion of device only.
62	Insulation Resistance	6	Conducted on devices molded of rubber or similar materials, or any material containing enough free carbon to render the material grey or black.
63	Conductor Secureness	6	Plugs employing wire leads only.
64	Tightening Torque	6	Plugs with wire-binding screws with pitch greater than that specified in Table 12.1.
154	Millivolt Drop	6	
155	Overload		
156	Heating		
157	Millivolt Drop (Repeated)		
158	Crushing	6	
159	Mechanical Endurance	6	Not required for thermostatically-controlled appliance plugs.
160	Accelerated Aging	6	Devices employing rubber cord guards.
161	Cord Guard	6	

<sup>a</sup> A set of representative devices may be used for more than one group of tests if agreeable to all concerned.

All Devices

## 55 Comparative Tracking Index Test

55.1 A polymeric material used for electrical insulation or enclosure of live parts, evaluated in accordance with Exception No. 1 to 8.3.1 and tested in accordance with the Comparative Tracking Index and Comparative Tracking Performance Level Class of Electrical Insulation Materials test described in the Standard for Polymeric Materials – Short Term Property Evaluations, UL 746A, shall have a performance level class value not greater than 3.

## 56 Glow Wire Test

56.1 A polymeric material used for electrical insulation or enclosure of live parts and evaluated in accordance with Exception No. 1 of 8.3.2, shall be tested in accordance with the requirements of 56.2 in order to determine its resistance to ignition from overheated conductors caused by circuit overloads.

56.2 Devices are to be subjected to the Glow-Wire End-Product Test described in the Standard for Polymeric Materials – Use in Electrical Equipment Evaluations, UL 746C. As a result of this test, there shall not be ignition of the insulating material during 30 seconds of application of the probe at a glow-wire temperature of 650°C for all devices.

## 57 High-Current Arc Resistance to Ignition Test

57.1 A polymeric material used for electrical insulation or enclosure of live parts and evaluated in accordance with Exception No. 2 to 8.3.2, when tested as described in 57.2 – 57.6, shall not ignite within the number of arcs specified in Table 57.1 for the flame class of the insulating material. In addition, there shall not be dielectric breakdown caused by formation of a permanent carbon conductor path.

*Exception No. 1: An insulating material used in the face of a female outlet device that has been subjected to the Resistance to Arcing Test described in Section 91 or 114, as appropriate, is not required to be subjected to this test.*

*Exception No. 2: An insulating material that has previously been accepted for use in the face of a female outlet device as specified in Exception No. 1 may be judged acceptable for use in other applications without being subjected to this test.*

**UL COPYRIGHTED MATERIAL –  
NOT AUTHORIZED FOR FURTHER REPRODUCTION OR  
DISTRIBUTION WITHOUT PERMISSION FROM UL**

**Table 57.1**  
**High-current arc resistance to ignition test arcing criteria**

Flame class	No. of arcs
HB	60
V-2, VTM-2	15
V-1, VTM-1	15
V-0, VTM-0	15

57.2 When preparing devices for test, the condition that will cause the greatest arcing near the material being tested in the device is to be simulated as follows:

- a) If the live parts are in direct contact with the polymeric material or located less than 1/32 inch (0.8 mm) from the polymeric material, the moving electrode is to be positioned on the surface of the material. The test arc is to be established between a live part acting as the fixed electrode and any adjacent part where breakdown is likely to occur. For example, if the material being tested is used in the face of an attachment plug, one line blade is to be connected to the test circuit as the fixed electrode.
- b) If the live parts are located at least 1/32 inch (0.8 mm) but less than 1/2 inch (12.7 mm) from the material, both the fixed and moving electrodes are to be positioned above the surface of the material at a distance equal to the minimum spacing between the live part and the material.

57.3 The test circuit is to provide test currents and test voltages equal to the current and voltage ratings of the device to be tested, but not exceeding 30 A or 240 V ac in any case. The test arc is to be established between a fixed electrode and a moving electrode consisting of a copper or stainless steel conductive probe. Each device is to be positioned with the electrodes making initial contact. The circuit is to be energized and the cyclic arcing started. The electrodes are to be drawn apart a distance not exceeding either 3/64 inches (1.2 mm) for a device rated 250 V or less and 1/8 inch (3.2 mm) for a device rated more than 250 V. The arc is to be used to attempt to ignite materials forming parts of the enclosure or to ignite materials located between the parts of different potential. The moving electrode is to be used to break through insulation, create arc tracking or create a carbon build-up across the surface of the insulating material at a rate of 30 to 40 arc separations per minute.

57.4 Immediately following the completion of the arcing portion of the test, the device is to be subjected to a 50 to 60 Hz essentially sinusoidal potential applied as described in 57.5 between live parts of opposite polarity and between live parts and dead metal parts. The test potential is to equal twice the rated voltage of the device plus 1000 V.

57.5 The device is to be tested by means of a 500 VA or larger capacity transformer whose output voltage is essentially sinusoidal and can be varied. The applied potential is to be increased from zero until the required test level is reached, and is to be held at that level for one minute. The increase in the applied potential is to be at a uniform rate and as rapid as is consistent with its value being correctly indicated by a voltmeter.

57.6 If the output of the test-equipment transformer is less than 500 volt-amperes, the equipment is to include a voltmeter in the output circuit to indicate the test potential directly.

### 58 Mold Stress Relief Test

58.1 As a result of temperature conditioning specified in 58.2, there shall not be any warpage, shrinkage or other distortion that results in any of the following:

- a) Making uninsulated live parts, other than exposed wiring terminals, or internal wiring accessible to contact, by the probe illustrated in Figure 9.1.
- b) Defeating the integrity of the enclosure so that acceptable mechanical protection is not afforded to the internal parts of the device.
- c) Interference with the operation, function or installation of the device. The outlet slot openings of a female device shall be capable of receiving a fully inserted attachment plug of the intended configuration.
- d) A condition that results in the device not complying with the strain relief requirements, if applicable.
- e) A reduction of spacings between uninsulated live parts of opposite polarity, uninsulated live parts and accessible dead or grounded metal below the minimum acceptable values.
- f) Any other evidence of damage that could increase the risk of fire or electric shock.

*Exception: Devices employing only thermosetting materials are not required to be subjected to this test, including thermosetting elastomeric materials such as neoprene (chloroprene butadiene) rubber (CBR), ethylene/propylene/diene (EPDM), natural rubber (NR), nitrile rubber (NBR), styrene (butadiene) rubber (SBR), and silicone rubber (SIR).*

58.2 The devices are to be placed in a circulating air oven maintained at a temperature of 70°C (158°F) for 7 hours. The devices are to be removed from the oven and allowed to cool to room temperature before determining compliance.

58.3 Immediately following the completion of this test, the devices are to be subjected to a repeated Dielectric Voltage-Withstand Test as described in Section 60. The devices are not required to be subjected to the humidity conditioning described in 60.1.2.

## 59 Moisture Absorption Resistance Test

59.1 Moisture-resistant insulating materials shall not absorb more than 6% of water by mass.

59.2 The material is to be:

- a) Dried at 105 ±5°C for 1 hour;
- b) Weighed ( $W_1$ );
- c) Immersed in distilled water at 23 ±1°C for 24 hours;
- d) Removed from the distilled water and the excess surface moisture wiped off; and
- e) Reweighed ( $W_2$ ).

The moisture absorbed by the material is to be calculated as:

$$\frac{W_2 - W_1}{W_1} \times 100\%$$

*Exception: A material tested in accordance with Test Method for Water Absorption of Plastics (ASTM D 570) described in the Standard for Polymeric Materials – Short Term Property Evaluations, UL 746A, is not required to be tested.*

## 60 Dielectric Voltage-Withstand Test

### 60.1 Devices for fixed or permanent installation

60.1.1 Devices intended for fixed or permanent installation including appliance, fixture or equipment outlets, inlets, and receptacles, shall withstand without breakdown a 50 – 60 Hz essentially sinusoidal potential applied as described in 60.1.3 for one minute, immediately following the humidity conditioning described in 60.1.2, between the following:

- a) Live parts of opposite polarity, and
- b) Live parts and grounding or dead metal parts including both the equipment grounding path and the mounting means of an isolated-ground receptacle.

*Exception: Devices employing polymeric materials consisting wholly of ceramic, thermoset, thermoplastic or elastomeric materials are not required to be subjected to the humidity conditioning.*

**UL COPYRIGHTED MATERIAL –  
NOT AUTHORIZED FOR FURTHER REPRODUCTION OR  
DISTRIBUTION WITHOUT PERMISSION FROM UL**

60.1.2 Mating attachment plugs with solid blades are to be inserted into the contact openings of three of the six devices. The devices are then to be placed into an environmental chamber and subjected to the following conditions:

- a) 4 hours at a temperature of  $75 \pm 1^{\circ}\text{C}$  ( $167 \pm 1.8^{\circ}\text{F}$ ) at a relative humidity of  $92 \pm 3$  percent.
- b) 16 hours at a temperature of  $75 \pm 1^{\circ}\text{C}$  ( $167 \pm 1.8^{\circ}\text{F}$ ) at a relative humidity of  $40 \pm 3$  percent.
- c) 4 hours at a temperature of  $30 \pm 1^{\circ}\text{C}$  ( $86 \pm 1.8^{\circ}\text{F}$ ) at a relative humidity of  $60 \pm 3$  percent.

60.1.3 Upon completion of the humidity conditioning, the device is to be tested by means of a 500 VA or larger capacity transformer whose output voltage is essentially sinusoidal and can be varied. The applied potential is to be increased from zero until the required test level is reached, and is to be held at that level for one minute. The increase in the applied potential is to be at a uniform rate and as rapid as is consistent with its value being correctly indicated by a voltmeter. The test potential is to be 2000 V for devices rated 300 V or less and 3000 V for devices rated greater than 300 V.

60.1.4 The mating attachment plugs used in 60.1.2 are to be capable of withstanding the application of a 2500 V potential for devices rated 300 V or less and a 3500 V potential for devices rated greater than 300 V.

60.1.5 If the output of the test-equipment transformer is less than 500 volt-amperes, the equipment is to include a voltmeter in the output circuit to indicate the test potential directly.

60.1.6 If the receptacle is provided with break-off tabs for feed-through wiring, the tabs are to be removed immediately following the completion of the test described in 60.1.3. A test potential of 2000 V is then to be applied again across the two adjacent line terminals.

## 60.2 Cord-connected devices

60.2.1 Devices intended for installation on flexible cords including attachment plugs, cord connectors, and current taps, shall be capable of withstanding the application of an ac potential of 1000 V plus 2 times the rated voltage applied for a period of one minute between live parts of opposite polarity and between live parts and grounding or dead metal parts.

## 61 Accelerated Aging Tests

### 61.1 General

61.1.1 A device employing one of the insulating materials tabulated in the Exception to 8.4.1 in an insulation or enclosure application shall be subjected to one of the following tests as applicable.

### 61.2 Rubber, EPDM, and TEE compounds

61.2.1 A device employing a rubber, EPDM, or TEE compound shall not show any apparent deterioration and no greater change in hardness than ten units as a result of the test described in 61.2.2 – 61.2.4.

61.2.2 A complete device is to be used for this test. The hardness of the material is to be determined as the average of five readings with an appropriate gauge, such as the Rex hardness gauge or the Shore durometer. The device is to be placed in a full-draft air-circulating oven for 70 hours at a temperature of 100°C (212°F). The device is to be allowed to rest at room temperature for four or more hours after removal from the oven. The hardness is to be determined again as the average of five readings. The difference between the average original hardness reading and the average reading taken after exposure is the change in hardness.

*Exception: As an alternative to testing on a complete device, representative plaques or bars of the insulating material which measure a minimum of 1 inch (25.4 mm) in diameter by 1/4 inch (6.4 mm) thick are to be used.*

61.2.3 Following the accelerated aging conditioning described in 61.2.2, a device having male blades supported by the material under test shall be capable of withstanding the applicable Security of Blades Test described in Section 66 or 81.

61.2.4 The accelerated-aging tests described in 61.2.1 – 61.2.3 are to be made on each color of material and on each basic rubber, EPDM, or TEE material employed for the device.

### 61.3 PVC compounds and copolymers

61.3.1 A device employing polyvinyl chloride or one of its copolymers shall not show any cracks, severe discoloration, or other visible signs of deterioration of the molding material as a result of this test.

61.3.2 The device is to be placed in a full-draft air-circulating oven for 96 hours at a temperature of 100°C (212°F). The device is to be allowed to rest at room temperature for at least one hour after removal from the oven. Warping or distortion of the device housing that occurs as a result of the oven conditioning shall not be considered to be a sign of deterioration.

*Exception: As an alternative to testing on a complete device, representative plaques or bars of the insulating material which measure a minimum of 1 inch (25.4 mm) in diameter by 1/4 inch (6.4 mm) thick are to be used.*

## 62 Insulation Resistance Test

62.1 When determined as described in this section, the insulation resistance shall not be less than 100 megohms between:

- a) Live parts of opposite polarity,
- b) Live parts and dead-metal parts that are exposed to contact by persons or that may be grounded in service, and
- c) Live parts and any surface of insulating material that is exposed to contact by persons or that may be in contact with ground in service.

62.2 The insulation resistance measurement is to be made on rubber and similar materials of any color. Other materials are to be tested if they contain free carbon in such quantity that it renders the material grey or black.

62.3 To determine compliance with the requirement in 62.1, the insulation resistance is to be measured by a magneto megohmmeter that has an open-circuit output of 500 V or by equivalent equipment.

62.4 The use of a megohmmeter between metal parts requires no special clarification or instruction. However, in measuring insulation resistance to the surface of an insulating material, it is necessary to apply an electrode to the insulating material as described in 62.5.

62.5 A quantity of No. 7 lead or nickel-plated lead drop shot (approximate diameter 0.10 inch or 2.5 mm) is to be placed in a container that is open at the top. After cord holes or other openings through which the shot could enter have been carefully plugged with a high-resistance insulating material, the device is to be immersed in the shot so that the shot serves as an electrode in contact with the surface to which the test is to be applied.

62.6 All rubber parts are to be kept for at least 48 hours at room temperature before being subjected to the test mentioned in 62.3.

## 63 Conductor Secureness Test

63.1 If a conductor or lead is connected to an element (male blade or female contact) of a device before the element has been assembled into the device, the connection shall not break under a pull applied for 1 minute between the element and the conductor before the element has been assembled into the device. A force of 20 lbf (89 N) is to be applied if the conductor is 18 AWG (0.82 mm<sup>2</sup>) or larger in size. If a smaller conductor is used, the force is to be 8 lbf (36 N).

63.1 revised November 16, 2007

63.2 While the test mentioned in 63.1 is being performed, the angle between the element and the conductor or lead is to be that used in the completely assembled device. The force is to be applied gradually.

**UL COPYRIGHTED MATERIAL –  
NOT AUTHORIZED FOR FURTHER REPRODUCTION OR  
DISTRIBUTION WITHOUT PERMISSION FROM UL**



## 64 Tightening Torque Test

64.1 A No. 8 or larger wire-binding screw having more than 32 threads per inch (per 25.4 mm) shall be capable of withstanding the torque application described in 64.2 without stripping either the screw threads or the terminal plate threads or damaging the slot in the head of the screw.

64.2 Six devices are to be tested. Solid 14 AWG (2.1 mm<sup>2</sup>) copper wire is to be placed under the screw head and wrapped 2/3 – 3/4 turn around the screw. The screw is then to be tightened with a clutch-type torque screwdriver which has been calibrated and preset to release at 16 lbf-in (1.8 N·m).

64.2 revised November 16, 2007

## ATTACHMENT PLUGS

All Devices

### 65 General

65.1 The performance of an attachment plug is to be investigated by means of the applicable tests described in Sections 55 – 64, and 66 – 79. For Hospital Grade devices, see Supplement SD.

### 66 Security of Blades Test

#### 66.1 General

66.1.1 The blades and pins of an attachment plug rated 15 A or less, and 250 V or less, shall be capable of withstanding a pull of 20 lbf (89 N) for 2 minutes without loosening. In a device of nonrigid construction (when, for example, a soft, molded material is used) a residual displacement of either blade of more than 3/32 inch (2.4 mm) measured 2 minutes after the removal of the weight is not acceptable. See 61.2.3.

*Exception: This requirement does not apply to a special-purpose attachment plug that is intended for use only with a corresponding cord connector and that is not interchangeable with any of the attachment plugs illustrated in Figure C3.8 or in Wiring Devices – Dimensional Specifications, ANSI/NEMA WD6.*

66.1.2 The device is to be wired in the intended manner and then supported on a horizontal steel plate with the blades, pins, or both projecting downward through a single hole with the smallest dimension through which the blades, pins, or both will be permitted to pass through. A device whose flexible cord is assembled to the blades at the factory is to be tested with a cord approximately 6 inches (150 mm) in length.

66.1.3 A weight that exerts a force of 20 lb (89 N) is to be supported by each blade or pin in succession. The pull is to be gradually applied.

66.1.4 If parallel blades are involved and the connection of wiring to the blades in the field requires disassembly of the blades from the body so that the secureness of each blade is dependent to some degree on the assembly of the other blade, the two blades are also to be tested together. A rigid pin is to be placed in holes that may be drilled in the blades if not provided, and a weight that exerts a force of 20 lb (89 N) is to be placed on the rigid pin, centered between the blades.

## 66.2 Self-hinged plugs

66.2.1 If the attachment plug employs a self-hinge that is relied upon to hold the plug face in place, the tests described in 66.1.1 – 66.1.4 are to be repeated with the hinges cut. The device under test is to be supported such that the separation of the plug face from the enclosure is not restricted. If unacceptable results are obtained, a separate set of six devices is to be subjected to the Self-Hinge Flexing Test described in Section 71.

## 67 Secureness-Of-Cover Test

67.1 The disc or separable cover of an attachment plug shall remain capable of being mechanically secured after 5 cycles of removal and replacement and after conditioning as described in 67.2.

67.2 Prior to testing, the disc or separable cover is to be subjected to  $85 \pm 5$  percent relative humidity at  $30.0 \pm 2.0^\circ\text{C}$  ( $86.0 \pm 3.6^\circ\text{F}$ ) for 24 hours.

## 68 Crushing Test

68.1 An attachment plug having a 1-15P, 2-15P, 5-15P, or 6-15P configuration shall be capable of withstanding for 1 minute a crushing force of 75 lbf (334 N) applied in any direction perpendicular to its major axis.

68.2 Any testing equipment that can apply a steady force of 75 lbf (334 N) to the plug may be employed. The plug is to be tested between two 1/2-inch (13-mm) or thicker parallel flat maple blocks. The crushing force is to be applied gradually.

## 69 Attachment Plug Grip Tests

69.1 An attachment plug having a 1-15P configuration is to be tested as described in this section to determine compliance with 17.2.1.

69.2 Prior to testing, the reference plug shown in Figure 69.1 is to be cleaned with a metal cleaner. The reference plug, the test plugs, and the hands of each individual conducting the test are to be washed with soap and water, rinsed, and then dried.

Figure 69.1  
Reference plug

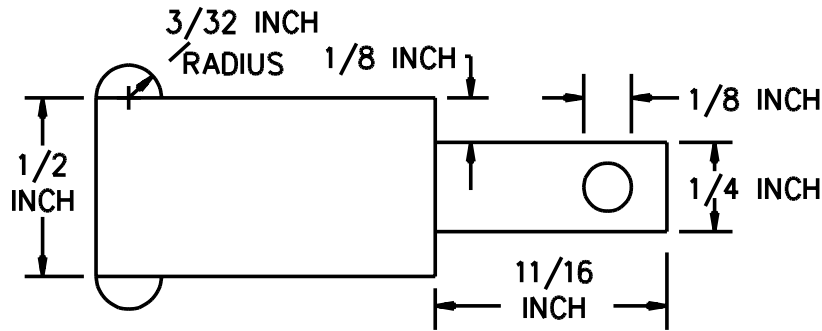

MATERIAL - BRASS

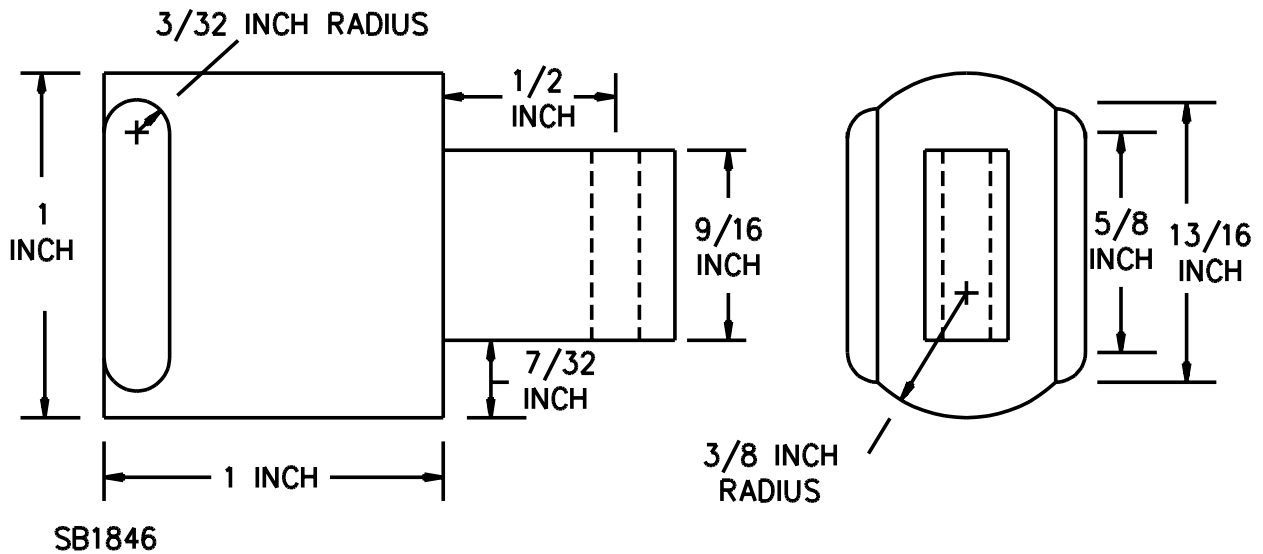

SB1846

inch	3/32	1/8	7/32	1/4	3/8	1/2
mm	2.4	3.2	5.6	6.4	9.7	12.7
inch	9/16	5/8	11/16	13/16	1.0	
mm	14.3	15.9	17.5	20.6	25.4	

UL COPYRIGHTED MATERIAL -  
NOT AUTHORIZED FOR FURTHER REPRODUCTION OR  
DISTRIBUTION WITHOUT PERMISSION FROM UL

Figure 69.2  
Typical test apparatus  
TOP VIEW

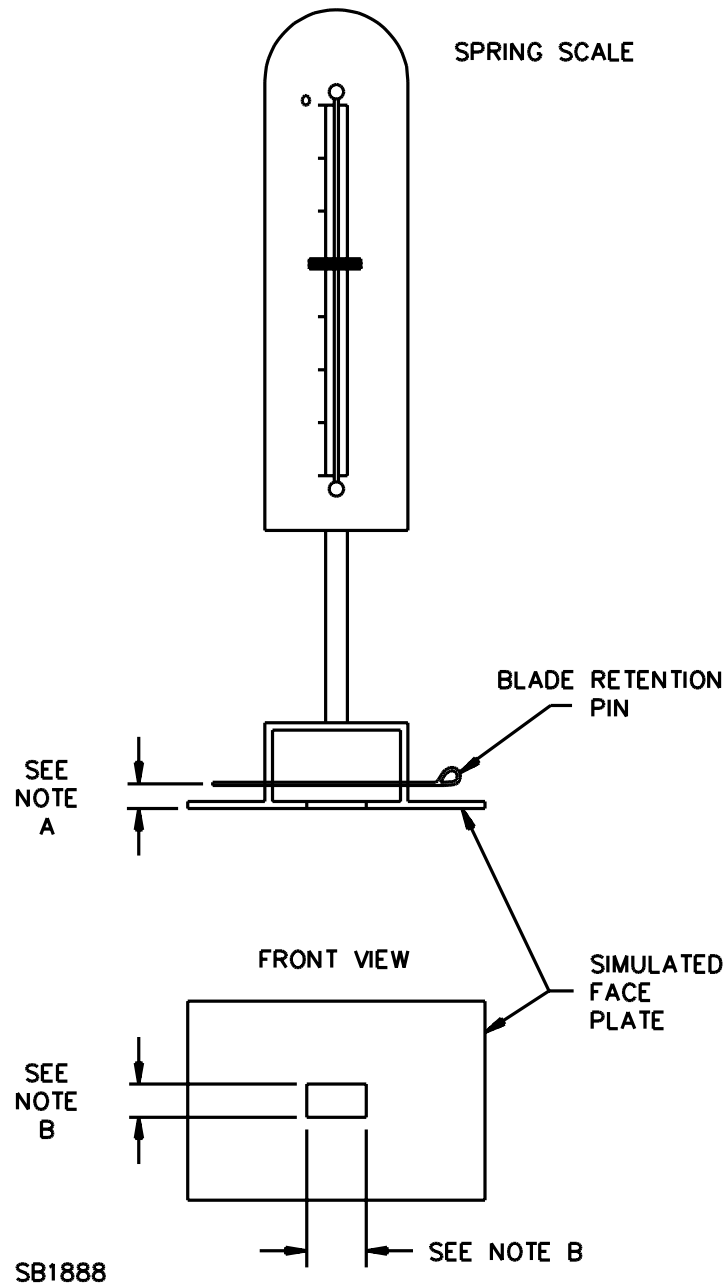

NOTES

A – Retaining pin through blades spaced to keep plug close to plate

B – Large enough for blades to pass through

*UL COPYRIGHTED MATERIAL –  
NOT AUTHORIZED FOR FURTHER REPRODUCTION OR  
DISTRIBUTION WITHOUT PERMISSION FROM UL*

69.3 The test apparatus is to consist of a spring scale equipped with a means to securely attach both the reference plug and test devices in a manner that reduces the likelihood of rotational movement during pulls. A simulated face plate, having an opening for the plug blades, is to be secured to the movable member. The mounting arrangement for the plug being tested is to be such that the face of the plug is flush with the face plate. A typical apparatus is shown in Figure 69.2.

69.4 A test plug, without cord installed, is to be securely attached to the test apparatus. The individual performing the test is to grip the test plug with either hand in a manner intended to apply the maximum pull force. A steady straight pull is to be applied until the plug pulls free from the individual's hand. The individual applying the force is not to view the force indicator during the pull. The maximum pull force applied during the pull is to be recorded. Immediately following the pull test, the reference plug is to be attached to the test apparatus and a comparison pull made using the same hand. The maximum pull force is to be recorded. The ratio of the force for the test plug to the reference plug is to be calculated and recorded.

69.5 The comparison pull procedure described in 69.4 is to be repeated on the same plug an additional two times by the same individual. The ratio for each pair of pulls (test/reference) is to be calculated and recorded.

69.6 Each individual is to test three plugs as described in 69.4 and 69.5 with the ratio for each pair of pulls being calculated and recorded for all three plugs.

69.7 Two additional individuals are to test three plugs each (for a total of 9 comparison pulls per individual), as described in 69.4 – 69.6. The ratio for each pair of pulls (test/reference) is to be calculated and recorded.

69.8 The results are considered acceptable if all of the following conditions are met:

- a) The ratio for each pair of pulls (test/reference) is 0.55 or larger for at least two pulls (of the three pulls performed) on each plug,
- b) At least two (of the three) plugs tested by each individual comply with (a), and
- c) At least two individual's test results comply with (b).

69.9 If only one individual obtains results that comply with 69.8 (b), at the manufacturer's request, two individuals not previously involved in the testing may test three plugs each as described in 69.4 – 69.6. The results are considered acceptable if both individual's test results comply with 69.8 (a) and (b).

## 70 Integrity of Assembly Test

### 70.1 General

70.1.1 An attachment plug shall not experience breakage or separation of the device body, detachment of any cord conductor, or any other damage that could increase the risk of fire or electric shock, when tested as described in this section.

*Exception No. 1: A device intended for use with a strain-relief knot as described in 13.3 is not required to be subjected to this test.*

*Exception No. 2: A strain-relief that consists of a cord clamp located outside the wiring compartment and that is tightened by one or more screws is not required to be subjected to this test.*

*Exception No. 3: Attachment plugs employing pin-type terminals instead shall be subjected to the Strain Relief Test, Section 77.*

*Exception No. 4: Hospital Grade attachment plugs shall instead be subjected to the Strain Relief Test, Section SD5.*

70.1.2 A field-wired device is to be wired in accordance with the manufacturer's instructions using 12 inch (305 mm) lengths of the sizes and types of flexible cord chosen to represent the range of cords intended for use with the device. See Reference No. 4 of Table 163.1.

70.1.3 The device is to be anchored securely by the blades and the cord is to be pulled steadily as follows:

- a) 30 lbf (133 N) for a cord with 18 AWG (0.82 mm<sup>2</sup>) or larger conductors, and
- b) 20 lbf (89 N) for a cord with conductors smaller than 18 AWG (0.82 mm<sup>2</sup>),

for 1 minute in the direction perpendicular to the plane of the cord entrance.

70.1.3 revised November 16, 2007

### 70.2 Self-hinged plugs

70.2.1 If the attachment plug employs a self-hinge that is relied upon to hold the flexible cord in place, the tests described in 70.1.1 – 70.1.3 are to be repeated with the hinges cut. If unacceptable results are obtained, a separate set of six devices is to be subjected to the Self-Hinge Flexing Test described in Section 71.

## 71 Self-Hinge Flexing Test

71.1 A self-hinge that is relied upon to maintain the integrity of the enclosure or strain relief after an attachment plug is assembled shall not break, crack, or experience other damage as a result of this test.

71.2 Three groups of six devices each shall be tested as follows:

- a) Group 1 – As received;
- b) Group 2 – Oven conditioned for 168 hours at 100°C (212°F); and
- c) Group 3 – Cold conditioned for 2 hours at -10°C (14°F) and allowed to return to room temperature.

71.3 The hinge of each device shall be completely opened and closed for 100 cycles of operation.

## 72 Terminal Temperature Test

72.1 When tested as described in this section, the temperature rise of an attachment plug for use with a flexible cord shall not be more than 30°C (54°F).

*Exception: An attachment plug employing wire-binding screws, pressure wire terminals or soldering lugs, or with factory-wired cord connections that are soldered, brazed, or welded, is not required to be subjected to this test.*

72.2 The plug is to carry the current corresponding to the capacity of the maximum size of cord that the device is intended to accommodate. The maximum size of cord that the device is intended to accommodate anticipates the use of cord with ampacity that does not exceed the maximum current rating of the device. If the device can accommodate a cord with an ampacity that exceeds its maximum ampere rating, the test is to be made at maximum rated current of the device with conductors no larger than necessary to carry that current.

72.3 Temperatures are to be measured by means of thermocouples attached to the wiring terminals or cord connections.

*Exception: If the wiring terminals or cord connections are not accessible for mounting thermocouples, the thermocouples are to be attached to the blades as close as possible to the face of the device.*

72.4 Temperature readings are to be obtained by means of thermocouples consisting of 28 – 32 AWG (0.08 – 0.032 mm<sup>2</sup>) iron and constantan wires. It is a common practice to employ thermocouples consisting of 30 AWG (0.05 mm<sup>2</sup>) iron and constantan wires with a potentiometer type of indicating instrument. This equipment will be used if a referee measurement of temperature is necessary.

72.4 revised November 16, 2007

### 73 Fuseholder Temperature Test

73.1 When tested as described in this section, the temperature rise of an attachment plug incorporating a fuseholder shall not exceed the following:

- a) 30°C (54°F) on the fuse clips when tested with a dummy fuse;
- b) 85°C (153°F) on the fuse clips when tested with a live fuse;
- c) 30°C (54°F) at the wiring terminals or cord connections at any time (see 73.7); and
- d) The relative thermal index of the surrounding insulating material, minus an assumed ambient of 25°C (77°F), at any time (see 73.7).

73.2 The test is to be conducted on a set of six previously untested devices. The test may be conducted with either a live fuse or a dummy fuse (see 73.6 and 73.7).

*Exception: The test may be conducted in conjunction with the Terminal Temperature Test, Section 72, if agreeable to all concerned.*

73.3 The devices are to be wired in a series circuit with the blades of the attachment plugs connected by the shortest possible length of solid copper wire soldered across the blades. Each connection to the device being tested is to be made by means of a 12-inch (300-mm) or greater length of the appropriate type of flexible cord that has an ampacity at least equal to that of the device. Wire of the intended ampacity is to be used regardless of the size of the cord which is intended to be used with the device.

73.4 Temperatures are to be measured by means of thermocouples attached to the fuse clips, the insulating material of the device body in proximity to the fuseholder, and the wiring terminals or cord connections.

*Exception: If the wiring terminals or cord connections are not accessible for mounting thermocouples, the thermocouples are to be attached to the blades as close as possible to the face of the device.*

73.5 The test is to continue until stabilized temperatures are attained. A temperature is considered to be stabilized when three consecutive readings, taken at 5 minute intervals, indicate no further rise above the ambient temperature.

73.6 If the test is to be conducted with a live fuse, the devices are to be tested with the largest ampere-rated fuse intended for use with the device installed and subjected to a test current equal to the maximum fuse ampere rating.

73.7 If the test is to be conducted with a dummy fuse, the devices are to be subjected to a test current equal to the maximum ampere rating of the intended fuse. The dummy fuse size for devices incorporating Class CC, G, H, J, K, or R is to be as specified in the Standard for Fuseholders – Part 1: General Requirements, UL 4248-1, the Standard for Fuseholders – Part 4: Class CC, UL 4248-4, the Standard for Fuseholders – Part 5: Class G, UL 4248-5, the Standard for Fuseholders – Part 6: Class H, UL 4248-6, the Standard for Fuseholders – Part 8: Class J, UL 4248-8, the Standard for Fuseholders – Part 9: Class K, UL 4248-9, the Standard for Fuseholders – Part 11: Type C (Edison Base) and Type S Plug Fuse, UL 4248-11, the Standard for Fuseholders – Part 12: Class R, UL 4248-12, and the Standard for Fuseholders – Part 15: Class T, UL 4248-15. The dummy fuse size for devices employing miscellaneous, miniature and

**UL COPYRIGHTED MATERIAL –  
NOT AUTHORIZED FOR FURTHER REPRODUCTION OR  
DISTRIBUTION WITHOUT PERMISSION FROM UL**



micro fuses is to be as indicated in Table 73.1. To represent the heating of a live fuse, 20°C (36°F) is to be added to the recorded temperature rise on the wiring terminals, cord connections, and surrounding insulating materials.

73.7 revised November 16, 2007

**Table 73.1**  
**Nominal dimensions of dummy fuses for miscellaneous, miniature and micro fuses**

Size of fuse	Dimensions		
	Outside diameter	Wall thickness	Length
5 x 20 mm (0.2 x 0.8 inches)	5 mm (0.2 inches)	1.2 mm (0.047 inches)	20 mm (0.8 inches)
1/4 x 1-1/4 inches (6.4 x 31.8 mm)	0.25 inches (6.4 mm)	0.049 inches (1.2 mm)	1-1/4 inches (31.8 mm)

73.8 The thermocouples are to consist of 28 – 32 AWG (0.08 – 0.032 mm<sup>2</sup>) iron and constantan wires. It is a common practice to employ thermocouples consisting of 30 AWG (0.05 mm<sup>2</sup>) iron and constantan wires with a potentiometer type of indicating instrument. This equipment will be used if a referee measurement of temperature is necessary.

73.8 revised November 16, 2007

## Pin-Type Terminals

### 74 General

74.1 In addition to the general performance requirements for attachment plugs, an attachment plug with pin-type terminals shall comply with the requirements in Sections 75 – 79.

### 75 Assembly Test

75.1 An attachment plug with pin-type terminals shall be able to be readily assembled to the flexible cords with which it is intended to be used.

75.2 The device shall be assembled and tested with each of the sizes and types of flexible cords that it will physically accommodate following the instructions provided by the manufacturer. Proper assembly shall be determined by visual examination and compliance with the tests described in Sections 66 – 79.

*Exception: The device is not required to be assembled and tested with those cord types and sizes excluded by the marking specified in item (c) of Reference No. 5 of Table 163.1.*

## 76 Temperature Test

76.1 The temperature rise shall not be more than 30°C (54°F) when an attachment plug with pin-type terminals is carrying the current corresponding to the ampacity of the size cord that the device is intended to accommodate.

76.2 The test is to be conducted on devices assembled to flexible cords selected as follows:

- a) For an attachment plug intended to be used with 18 AWG (0.82 mm<sup>2</sup>) Types SP-1 and SPT-1 flexible cord, two sets of six devices each are to be assembled. One set is to be assembled using 18 AWG (0.82 mm<sup>2</sup>) polyvinyl chloride insulated Type SPT-1 cord having a maximum width of 0.205 inch (5.21 mm) and a maximum overall thickness of 0.110 inch (2.79 mm). The second set is to be assembled using 18 AWG (0.82 mm<sup>2</sup>) polyvinyl chloride insulated Type SPT-1 cord having a minimum overall width of 0.210 inch (5.33 mm).
- b) For an attachment plug intended for use with other types of flexible cord, consideration is to be given to the need for testing different types of cords and the effects of variations on insulation material and thickness for each type of flexible cord.
- c) For an attachment plug intended for use with more than one size of flexible cord, the temperature test is to be repeated for each size wire.

76.2 revised November 16, 2007

76.3 Each set is to be tested for temperature rise following assembly. Thermocouples are to be attached to the male blades of the attachment plug at points as close as possible to the male face. The assemblies are to be tested for 15 days without interruption. The device temperature is to be measured at the end of each working day.

76.4 Following the completion of this test, three assemblies using each of the flexible cord sizes and types specified in 76.2 are to be selected and subjected to the Dielectric Voltage-Withstand Test described in Section 79.

## 77 Strain Relief Test

77.1 When assembled to the intended flexible cord, an attachment plug with pin-type terminals shall withstand the straight pull described in this section without detachment of any cord conductor or any other evidence of damage that increases the risk of fire or electric shock.

77.2 The test is to be conducted on devices assembled to flexible cords selected as follows:

- a) For an attachment plug intended to be used with 18 AWG (0.82 mm<sup>2</sup>) Types SP-1 and SPT-1 flexible cord, two sets of six devices each are to be assembled using the smaller of the two cords indicated in 76.2.
- b) When cords other than 18 AWG (0.82 mm<sup>2</sup>) Types SP-1 and SPT-1 are to be used, device assemblies representing each size and type cord are to be tested. Consideration is to be given to the effects of anticipated variations in cord insulation material and thickness in selecting cords for the tests. Two sets with a minimum of three assemblies are to be tested using each representative size and type cord.

77.2 revised November 16, 2007

**UL COPYRIGHTED MATERIAL –  
NOT AUTHORIZED FOR FURTHER REPRODUCTION OR  
DISTRIBUTION WITHOUT PERMISSION FROM UL**

77.3 One set of devices for each cord size and type is to be subjected to the test described in 77.4 following assembly in the as-received condition. The second set is to be tested after being conditioned in a full-draft air-circulating oven for 30 days at 67.0°C (152.6°F).

77.4 While the attachment plug is securely supported by the blades, a pull is to be applied to the flexible cord for 1 minute of either:

- a) 30 lbf (133 N) when the conductors are 18 AWG (0.82 mm<sup>2</sup>) or larger, or
- b) 20 lbf (89 N) when the conductors are smaller than 18 AWG (0.82 mm<sup>2</sup>).

The direction of the force is to be perpendicular to the plane of the cord entrance.

77.4 revised November 16, 2007

## 78 Fault Current Test

78.1 When assembled to the intended flexible cord, an attachment plug with pin-type terminals shall withstand the applied fault current without ignition of the cotton or cord insulation. The circuit breaker shall operate when the test circuit is closed.

78.2 The test is to be conducted on devices assembled to flexible cords selected as follows:

- a) For an attachment plug intended to be used with 18 AWG (0.82 mm<sup>2</sup>) Types SP-1 and SPT-1 flexible cord, three sets of two devices each are to be tested using the larger of the two flexible cords described in 76.2.
- b) For an attachment plug intended to be used with other cord sizes and types, device assemblies representing each size and type of cord are to be tested. Consideration is to be given to the effects of variations in cord insulation material and thickness in selecting cords for the tests. Three sets of two devices each are to be tested using each representative size and type of cord.

78.2 revised November 16, 2007

78.3 The attachment plugs are to be assembled to a 2-ft (0.6 m) length of each size and type of flexible cords twisted and soldered at the end. The assemblies are to be tested as follows:

- a) The first set is to be subjected to the test described in 78.4 following assembly in the as-received condition.
- b) The second set is to be subjected to the test described in 78.4 after being subjected to a 15 lbf (67 N) strain relief test for 1 minute.
- c) The third set is to be subjected to the test described in 78.4 after being conditioned in an oven at 67.0°C (152.6°F) for 30 days.

78.4 A standard screw terminal receptacle of the 5-15R configuration (2-pole, 3-wire, 15A, 125V) is to be wired in a circuit capable of delivering 1000 A rms at 125 V when the system is short circuited at the testing terminals. The receptacle is to be wired to the testing terminals by 4 ft (1.2 m) of 12 AWG (3.3 mm<sup>2</sup>) wire. A thermal-type 20-A circuit breaker is to be connected between the receptacle and the testing terminals. The circuit breaker is to be calibrated and found to meet the calibration requirements for circuit

breakers. Cotton is to be placed around the attachment plug being tested. The male blades of the attachment plug are to be inserted into the contacts of the receptacle and the test circuit is to be closed by means of an external switching device.

78.4 revised November 16, 2007

## 79 Dielectric Voltage-Withstand Test

79.1 The assembly of a cord and attachment plug with pin-type terminals shall be capable of withstanding without breakdown, for a period of 1 minute, the application of a 60 Hz essentially sinusoidal potential of 1250 V between the two conductors of the flexible cord. Three assemblies are to be selected from the temperature test specified in Temperature Test, Section 76.

79.2 The test potential is to be supplied from a 500 V-A or larger capacity testing transformer whose output is essentially sinusoidal and can be varied. The applied potential is to be increased from zero until the required test voltage is reached, and is to be held at that voltage for a period of 1 minute. The increase in the applied potential is to be at uniform rate and as rapid as is consistent with its value being correctly indicated by the voltmeter.

## INLETS

All Devices

## 80 General

80.1 The performance of an inlet is to be investigated by means of the applicable tests described in Sections 55 – 64, and 81 – 85.

## 81 Security of Blades Test

81.1 The blades or grounding pin of an inlet employing a 1-15P, 2-15P, 2-20P, 5-15P, 5-20P, 6-15P, or 6-20P configuration shall be capable of withstanding a pull of 20 lbf (88 N) for 2 minutes without loosening.

81.2 The inlet is to be supported in a horizontal plane with the blades or pin projecting downward. If a hole is not provided in the blade, one may be drilled through the blade in order to support the test weight. A weight that exerts a force of 20 lbs (89 N) is to be supported by each blade or pin in succession. The pull is to be gradually applied.

**UL COPYRIGHTED MATERIAL –  
NOT AUTHORIZED FOR FURTHER REPRODUCTION OR  
DISTRIBUTION WITHOUT PERMISSION FROM UL**

## 82 Terminal Temperature Test

82.1 The temperature rise of an inlet intended for mounting in or on an outlet box and employing wire-binding screw or clamp terminals for field connection to branch-circuit conductors, when measured at the points described in 82.2, shall not be more than 30°C (54°F) when the device is carrying its maximum rated current.

82.2 Temperatures are to be measured by means of thermocouples attached to the wiring terminals of the inlet.

*Exception: When the wiring terminals are not accessible for mounting thermocouples, the thermocouples are to be attached to the blades as close as possible to the face of the inlet.*

82.3 The temperature test is to continue until stabilized temperatures are attained. A temperature is considered to be stabilized when three consecutive readings, taken at 5-minute intervals, indicate no further rise above the ambient temperature.

82.4 The generation of heat from sources other than the wiring terminals is to be minimized as much as possible. Each connection to the device being tested is to be made by means of a 12-inch (300-mm) or greater length of Type RH, Type TW, or other equivalent building wire. The wire size is to be determined using the appropriate value for the device's current rating based on the use of copper conductors with a temperature rating of 60°C (140°F) from Table 310-16 of the National Electrical Code, ANSI/NFPA 70.

82.5 The blades of the inlet are to be short-circuited by means of the shortest feasible lengths of solid copper wire soldered to the plug blades.

82.6 The terminals are to be tightened to the marked torque limit or, if no tightening torque is specified, to 9 in-lbf (1.0 N·m) for devices rated 15 A or less or 14 in-lbf (1.6 N·m) for devices rated greater than 15 A.

82.7 If an inlet incorporates both wire-binding screw and clamp-type pressure-wire terminals, three inlets are to be tested using the wire-binding screw terminals and three inlets are to be tested using the clamp terminals.

82.8 The thermocouples are to consist of 28 – 32 AWG (0.08 – 0.32 mm<sup>2</sup>) iron and constantan wires. It is a common practice to employ thermocouples consisting of 30 AWG (0.05 mm<sup>2</sup>) iron and constantan wires with a potentiometer type of indicating instrument. This equipment will be used if a referee measurement of temperature is necessary.

82.8 revised November 16, 2007

### 83 Fuseholder Temperature Test

83.1 When tested as described in this section, the temperature rise of an inlet incorporating a fuseholder shall not exceed the following:

- a) 30°C (54°F) on the fuse clips when tested with a dummy fuse;
- b) 85°C (153°F) on the fuse clips when tested with a live fuse;
- c) 30°C (54°F) at the wiring terminals or cord connections at any time (see 83.7); and
- d) The relative thermal index of the surrounding insulating material, minus an assumed ambient of 25°C (77°F), at any time (see 83.7).

83.2 The test is to be conducted on a set of six previously untested devices. The test may be conducted with either a live fuse or a dummy fuse (see 83.6 and 83.7).

*Exception: The test is not prohibited from being conducted in conjunction with the Terminal Temperature Test, Section 82.*

83.3 The devices are to be wired in a series circuit with the blades of the inlets connected by the shortest possible length of solid copper wire soldered across the blades. Type RH, Type TW, or equivalent building wires 12 inches (300 mm) long or greater are to be connected to the wiring terminals. Wire of the intended ampacity is to be used regardless of the size of the cord which is intended to be used with the device.

83.4 Temperatures are to be measured by means of thermocouples attached to the fuse clips, the insulating material of the device body in proximity to the fuseholder, and the wiring terminals or cord connections.

*Exception: When the wiring terminals or cord connections are not accessible for mounting thermocouples, the thermocouples are to be attached to the blades as close as possible to the face of the device.*

83.5 The test is to continue until stabilized temperatures are attained. A temperature is considered to be stabilized when three consecutive readings, taken at 5-minute intervals, indicate no further rise above the ambient temperature.

83.6 If the test is to be conducted with a live fuse, the devices are to be tested with the largest ampere-rated fuse intended for use with the device installed and subjected to a test current equal to the maximum fuse ampere rating.

83.7 If the test is to be conducted with a dummy fuse, the devices are to be subjected to a test current equal to the maximum ampere rating of the intended fuse. The dummy fuse size for devices incorporating Class CC, G, H, J, K, or R is to be as specified in the Standard for Fuseholders – Part 1: General Requirements, UL 4248-1, the Standard for Fuseholders – Part 4: Class CC, UL 4248-4, the Standard for Fuseholders – Part 5: Class G, UL 4248-5, the Standard for Fuseholders – Part 6: Class H, UL 4248-6, the Standard for Fuseholders – Part 8: Class J, UL 4248-8, the Standard for Fuseholders – Part 9: Class K, UL 4248-9, the Standard for Fuseholders – Part 11: Type C (Edison Base) and Type S Plug Fuse, UL 4248-11, the Standard for Fuseholders – Part 12: Class R, UL 4248-12, and the Standard for Fuseholders – Part 15: Class T, UL 4248-15. The dummy fuse size for devices employing miscellaneous, miniature and

**UL COPYRIGHTED MATERIAL –  
NOT AUTHORIZED FOR FURTHER REPRODUCTION OR  
DISTRIBUTION WITHOUT PERMISSION FROM UL**

micro fuses is to be as indicated in Table 83.1. To represent the heating of a live fuse, 20°C (36°F) is to be added to the recorded temperature rise on the wiring terminals, cord connections, or surrounding insulating materials.

83.7 revised November 16, 2007

**Table 83.1**  
**Nominal dimensions of dummy fuses for miscellaneous, miniature and micro fuses**

Size of fuse	Dimensions		
	Outside diameter	Wall thickness	Length
5 x 20 mm (0.2 x 0.8 inches)	5 mm (0.2 inches)	1.2 mm (0.047 inches)	20 mm (0.8 inches)
1/4 x 1-1/4 inches (6.4 x 31.8 mm)	0.25 inches (6.4 mm)	0.049 inches (1.2 mm)	1-1/4 inches (31.8 mm)

83.8 The thermocouples are to consist of 28 – 32 AWG (0.08 – 0.32 mm<sup>2</sup>) iron and constantan wires. It is a common practice to employ thermocouples consisting of 30 AWG (0.05 mm<sup>2</sup>) iron and constantan wires with a potentiometer type of indicating instrument. This equipment will be used if a referee measurement of temperature is necessary.

83.8 revised November 16, 2007

No Text on This Page

Document Was Downloaded By jianxiong chen For Use By KAI HUA (FOSHAN SHUNDE) ELECTRIC APPLIANCE CO LTD 22381 : 5/8/2008 - 10:34 AM

***UL COPYRIGHTED MATERIAL –  
NOT AUTHORIZED FOR FURTHER REPRODUCTION OR  
DISTRIBUTION WITHOUT PERMISSION FROM UL***



## Pressure-Wire Terminals

**84 General**

84.1 In addition to the requirements in Sections 80 – 83, the following types of inlets, intended for mounting in or on an outlet box, shall comply with the Strength of Insulating Base Test, Section 85, and with the applicable performance requirements in the Standard for Equipment Wiring Terminals for Use with Aluminum and/or Copper Conductors, UL 486E:

- a) An inlet rated less than 30 A and employing setscrew-type pressure-wire terminals for field connection to copper branch circuit conductors only.
- b) An inlet rated 35 A or greater and employing setscrew- or clamp-type pressure-wire terminals for field connection to copper branch circuit conductors only.

The copper test conductors to be used in these tests are to be selected in accordance with Table 84.1.

**Table 84.1**  
**Copper test conductor sizes**

Device rating, A	Conductor size, AWG
15	14 solid
	14 stranded
	12 solid
	12 stranded
20	12 solid
	12 stranded
30	10 solid
	10 stranded
50	6 stranded
60	4 stranded
100	1 stranded
200	30 stranded

84.2 An inlet rated less than 30 A, intended for mounting in or on an outlet box, and employing clamp-type pressure-wire terminals for use on copper alloy branch circuit conductors only, shall comply with the general requirements for inlets contained in Sections 80 – 83, only.

**UL COPYRIGHTED MATERIAL –  
NOT AUTHORIZED FOR FURTHER REPRODUCTION OR  
DISTRIBUTION WITHOUT PERMISSION FROM UL**

## 85 Strength of Insulating Base Test

85.1 An inlet intended for mounting in or on an outlet box and employing pressure-wire terminals for field connection to branch circuit conductors, shall not be damaged when 110 percent of the specified terminal tightening torque is applied to the wire securing means of the pressure-wire terminal which secures the maximum intended size conductor.

85.2 Damage is considered to have occurred if any cracking, bending, breakage, or displacement of the insulating base, current-carrying parts, assembly parts, or device enclosure reduces electrical spacings to less than those required, exposes live parts, or otherwise impairs the intended secure installation and use of the device.

85.3 The terminal tightening torque to be used for this test is to be that assigned by the manufacturer in accordance with 12.4.3 and marked in accordance with Reference No. 4 of Table 163.2.

## CORD CONNECTORS

All Devices

### 86 General

86.1 The performance of a cord connector is to be investigated by means of the tests described in Sections 55 – 64 and 87 – 103. For Hospital Grade devices, see Supplement SD.

86.2 A cord connector with a spring-activated latching mechanism shall be subjected to the tests described in Sections 87 – 90 with the mechanism defeated. If compliance with any of the tests in the sequence is unable to be determined, a new set of devices is to be subjected to the test sequence with the mechanism engaged. The cord connector shall then be subjected to the Latching Mechanism Test, Section 92.

### 87 Retention of Plugs Tests

87.1 The contacts of a 1-15R, 5-15R, 5-20R, 6-15R or 6-20R configuration cord connector shall retain an attachment plug so that a force greater than 3 lbf (13 N) is required to withdraw the plug when tested as described in this section.

*Exception: A cord connector that has provision for locking the plug in place after the blades have been inserted in the female contacts (such as a rotating collar) is not required to be subjected to this test.*

87.2 A cord connector with a spring-activated latching mechanism shall be subjected to this test with its mechanism defeated. See 86.2.

87.3 Each of six devices is to be subjected to ten conditioning cycles of insertion and withdrawal of a standard solid-blade attachment plug that has American National Standard detent holes in accordance with Wiring Devices – Dimensional Specifications, ANSI/NEMA WD6, in rigidly mounted blades, following which the plug is to be fully reinserted into the device. The mating plugs are to have the configuration indicated in Table 87.1. A pull of 3 lbf (13 N) in a direction perpendicular to the plane of the face of the cord connector and tending to withdraw the plug from the device is then to be applied to the plug for 1 minute. The displacement of the plug shall not be greater than 0.079 inch (2 mm).

**UL COPYRIGHTED MATERIAL –  
NOT AUTHORIZED FOR FURTHER REPRODUCTION OR  
DISTRIBUTION WITHOUT PERMISSION FROM UL**

**Table 87.1**  
**Mating plug configurations for plug retention**

Device under test	Mating plug	No. of devices tested
1-15R	1-15P	6
5-15R	1-15P	6
5-20R	1-15P	3
	5-20P <sup>a</sup>	3
6-15R	2-15P	6
6-20R	2-15P	3
	6-20P <sup>a</sup>	3

<sup>a</sup> Shall have the ground blade removed.

## 88 Overload Tests

### 88.1 General

88.1.1 A cord connector shall be capable of performing acceptably when subjected to the current overload test as described in this section. A cord connector additionally rated in horsepower shall also be capable of performing acceptably when subjected to the horsepower overload test as described in this section. In either case, there shall not be any electrical or mechanical failure of the device, opening of a line or grounding fuse, welding of the contacts, nor burning or pitting of the contacts that would affect the intended function of the device.

*Exception No. 1: A cord connector that is intended for disconnecting use only and not for current interruption, is not required to be subjected to this test. See also 162.6.*

*Exception No. 2: Either the current overload test or horsepower overload test may be omitted if it is obvious that one test is fully represented by the other.*

88.1.2 A cord connector with a spring-activated latching mechanism shall be subjected to this test with its mechanism defeated. See 86.2.

88.1.3 The device is to be mounted and wired to represent service conditions. Any metal armor is to be connected to the grounding conductor of the test circuit.

*Exception: Any metal armor on a nongrounding device is to be electrically positive with respect to the nearest arcing point of the device.*

88.1.4 The fuse in the grounding conductor is to be:

- a) A 15 A fuse if the device being tested is rated 30 A or less; or
- b) A 30 A fuse if the device being tested is rated more than 30 A.

The fuse in the test circuit is to have the next higher standard fuse rating than the value of the test current.

88.1.5 The potential of the test circuit is to be from 95 to 105 percent of the rating of the device in volts. Devices rated 250 V are to be tested on circuits with a potential to ground of 125 V. Cord connectors having other voltage ratings are to be tested on circuits involving full rated potential to ground, except for multi-phase rated devices which are to be tested on circuits consistent with their voltage ratings (for example, a 120/208 V, 3-phase device, is to be tested on a circuit involving 120 V to ground). Testing using a 60 Hz supply voltage may represent testing using a higher frequency supply voltage not exceeding 400 Hz.

88.1.6 Each of six devices is to be tested by machine or manually by inserting and withdrawing an attachment plug having rigidly secured solid blades that are connected through a flexible cord to a load. For devices with the 1-15R, 5-15R, 5-20R, 6-15R or 6-20R configurations, the mating plugs shall have the configurations specified in Table 88.1. When an equipment-grounding connection is provided in the device being tested, a grounding-type attachment plug is to be used and the grounding blade of the plug connected to the grounding contact of the device being tested. The grounding contact is then to be grounded through a fuse as specified in 88.1.4.

**Table 88.1**  
**Mating plug configurations for overload testing**

Device under test	Mating plug	No. of devices tested
1-15R	1-15P	6
5-15R	5-15P	6
5-20R	5-15P	3
	5-20P	3
6-15R	6-15P	6
6-20R	6-15P	3
	6-20P	3

88.1.7 For a device rated 20 A or less, the test machine is to withdraw and insert an unrestricted attachment plug with an average velocity of  $30 \pm 3$  inches/s ( $760 \pm 75$  mm/s) in each direction during a 2-1/2 inch (64 mm) stroke measured from the fully inserted position. The velocity is to be determined without the outlet device installed on the machine to eliminate restrictions on the plug motion.

88.1.8 For a device rated more than 20 A the test machine unrestricted plug velocity and stroke length are to be adjusted as necessary to obtain the maximum mating time required in 88.1.9.

88.1.9 The device is then to make and break the required test load for 50 cycles of operation at a rate no faster than 10 cycles per minute. The blade of the attachment plug is to mate with the female contact of the device for no more than 1 second for straight-blade devices, and 3 seconds for locking devices during each cycle. For locking devices, each cycle of operation is to include rotation of the test plug to the full lock position after insertion, and back to the unlocked position before withdrawal.

88.1.10 Blades or contacts are not to be adjusted, lubricated, or otherwise conditioned before or during either test. The attachment plug used for either test may be changed after 50 cycles.

88.1.11 In the event that unacceptable results are obtained in the machine testing described in 88.1.7 or 88.1.8, referee tests may be conducted manually under conditions similar to those described in 88.1.7 or 88.1.8.

**UL COPYRIGHTED MATERIAL –  
NOT AUTHORIZED FOR FURTHER REPRODUCTION OR  
DISTRIBUTION WITHOUT PERMISSION FROM UL**

## 88.2 Current overload test

88.2.1 The test current shall be 150 percent of the rated current of the device. For devices with standard configurations rated 125 V, 250 V, or 125/250 V illustrated in Wiring Devices – Dimensional Specifications, ANSI/NEMA WD6, the test is to be conducted on direct current. All other devices with standard configurations denoted as "AC" or "3-phase" are to be tested on alternating current. For devices with nonstandard configurations, the test is to be conducted using direct current with a resistive load, except that alternating current is to be used if the device is rated for alternating current only. Whenever alternating current is used for the test, the power factor of the load is to be from 0.75 to 0.80.

88.2.2 Testing of a device that has a dual voltage rating and a dual current rating is to be performed at the maximum rating in volts and with 150 percent of the rated current that corresponds to the maximum voltage rating.

*Exception: A test on alternating current is not required when equivalent results have been obtained from a direct potential that is equal to or greater than the alternating-potential rating.*

## 88.3 Horsepower overload test

88.3.1 If a separate horsepower overload test is conducted, the tests for the horsepower ratings are to be conducted on separate sets of previously untested devices. For devices with a phase to phase (L-L) and phase to neutral (L-N) horsepower rating, the test for each rating is to be conducted on a separate set of previously untested devices.

88.3.2 For devices with standard configurations illustrated in Wiring Device - Dimensional Specifications, ANSI/NEMA WD6, the test current corresponding to the AC horsepower rating shall be as specified in Table 88.2. The load for an alternating current horsepower rating is to have a power factor of 0.40 – 0.50. For devices with a voltage rating of 250 volts, the overload test for the phase to phase horsepower rating is to be conducted at both 208 V ac and 250 V ac. A single test may be conducted at 250 V ac and at the test current for 208 V ac, if agreeable to all parties.

*Exception: Devices having a L9-20R, L9-30R, L13-30R, L17-30R, L20-20R, L20-30R, L23-20R, L23-30R, SS1-50R, SS2-50R, TT-R, ML-1R, ML-2R, or ML-3R configuration or one of the configurations illustrated in Figures C3.8 – C3.12 do not have assigned horsepower ratings and are not required to be subjected to the horsepower overload test.*

88.3.3 For all devices with nonstandard configurations, the test current corresponding to the horsepower rating is to be as specified in the Standard for General-Use Snap Switches, UL 20, for a device having an alternating-current rating of 2 horsepower or less and as specified in the Standard for Enclosed and Dead-Front Switches, UL 98, for a device having an alternating-current rating of more than 2 horsepower. The load for an alternating current horsepower rating is to have a power factor of 0.40 – 0.50.

**Table 88.2**  
**Test current (locked rotor amperes) for horsepower rated NEMA configuration cord connectors**

NEMA configuration	AC HP rating <sup>a</sup>	LRA (amperes)	AC test voltage
1-15R	0.5	58.8	125
2-15R	1.5 <sup>b</sup>	60	250
		66	208
2-20R	2 <sup>b</sup>	72	250
		79.2	208
2-30R	2 <sup>b</sup>	72	250
		79.2	208
5-15R	0.5	58.8	125
5-20R	1	96	125
5-30R	2	144	125
5-50R	2	144	125
6-15R	1.5 <sup>b</sup>	60	250
		66	208
6-20R	2 <sup>b</sup>	72	250
		79.2	208
6-30R	2 <sup>b</sup>	72	250
		79.2	208
6-50R	3 <sup>b</sup>	102	250
		112.2	208
7-15R	2	59.8	277
7-20R	2	59.8	277
7-30R	3	84.7	277
7-50R	5	139.4	277
10-20R	2 L-L <sup>b</sup>	72	250
		79.2	208
	1 L-N	96	125
10-30R	2 L-L <sup>b</sup>	72	250
		79.2	208
	2 L-N	144	125
10-50R	3 L-L <sup>b</sup>	102	250
		112.2	208
	2 L-N	144	125
11-15R	2	50	250
11-20R	3	64	250
11-30R	3	64	250
11-50R	7.5	132	250
14-15R	1.5 L-L <sup>b</sup>	60	250
		66	208

**UL COPYRIGHTED MATERIAL –  
 NOT AUTHORIZED FOR FURTHER REPRODUCTION OR  
 DISTRIBUTION WITHOUT PERMISSION FROM UL**

Table 88.2 Continued on Next Page

Table 88.2 Continued

NEMA configuration	AC HP rating <sup>a</sup>	LRA (amperes)	AC test voltage
14-20R	0.5 L-N	58.8	125
	2 L-L <sup>b</sup>	72	250
		79.2	208
14-30R	1 L-N	96	125
	2 L-L <sup>b</sup>	72	250
		79.2	208
14-50R	2 L-N	144	125
	3 L-L <sup>b</sup>	102	250
		112.2	208
14-60R	2 L-N	144	125
	3 L-L <sup>b</sup>	102	250
		112.2	208
	2 L-N	144	125
15-15R	2	50	250
15-20R	3	64	250
15-30R	3	64	250
15-50R	7.5	132	250
15-60R	10	168	250
18-15R	2	55	208
18-20R	2	55	208
18-30R	3	71	208
18-50R	7.5	145.2	208
18-60R	7.5	145.2	208
L1-15R	0.5	58.8	125
L2-20R	2 <sup>b</sup>	72	250
		79.2	208
L5-15R	0.5	58.8	125
L5-20R	1	96	125
L5-30R	2	144	125
L6-15R	1.5 <sup>b</sup>	72	250
		79.2	208
L6-20R	2 <sup>b</sup>	72	250
		79.2	208
L6-30R	2 <sup>b</sup>	72	250
		79.2	208
L7-15R	2	59.8	277
L7-20R	2	59.8	277
L7-30R	3	84.7	277
L8-20R	3	51	480
L8-30R	5	84	480
L10-20R	2 L-L <sup>b</sup>	72	250

UL COPYRIGHTED MATERIAL –  
NOT AUTHORIZED FOR FURTHER REPRODUCTION OR  
DISTRIBUTION WITHOUT PERMISSION FROM UL

Table 88.2 Continued on Next Page

Table 88.2 Continued

NEMA configuration	AC HP rating <sup>a</sup>	LRA (amperes)	AC test voltage
L10-30R	1 L-N	79.2 96	208 125
	2 L-L <sup>b</sup>	72	250
	2 L-N	79.2	208
		144	125
L11-15R	2	50	250
L11-20R	3	64	250
L11-30R	3	64	250
L12-20R	5	45.6	480
L12-30R	10	84	480
L14-20R	2 L-L <sup>b</sup>	72	250
	1 L-N	79.2	208
		96	125
L14-30R	2 L-L <sup>b</sup>	72	250
	2 L-N	79.2	208
		144	125
L15-20R	3	64	250
L15-30R	3	64	250
L16-20R	5	45.6	480
L16-30R	10	84	480
L18-20R	2	55	208
L18-30R	3	71	208
L19-20R	5	45.6	480
L19-30R	10	84	480
L21-20R	2	55	208
L21-30R	3	71	208
L22-20R	5	45.6	480
L22-30R	10	84	480

<sup>a</sup> The phase to phase horsepower ratings are noted by "L-L". The phase to neutral ratings are identified by "L-N".

<sup>b</sup> Also suitable for 208 V motor applications at the indicated horsepower rating.



## 89 Temperature Test

89.1 The temperature rise of a cord connector measured at the points described in 89.3 shall not be more than 30°C (54°F) when the device is carrying its maximum rated current.

89.2 A cord connector with a spring-activated latching mechanism shall be subjected to this test with its mechanism defeated. See 86.2.

89.3 Each of six devices is to be tested. Temperatures are to be measured by means of thermocouples attached to the wiring terminals or cord connections.

*Exception: When the wiring terminals or cord connections are not accessible for mounting thermocouples or when the device does not have any wiring terminals, the thermocouples are to be attached to the blades of the mated attachment plug as close as possible to the face of the device*

89.4 The temperature test is to be made following the overload test on the devices and is to continue until stabilized temperatures are attained. A temperature is considered to be stabilized when three consecutive readings, taken at 5-minute intervals, indicate no further rise above the ambient temperature.

89.5 The generation of heat from sources other than the female contacts is to be minimized as much as possible. Each connection to the device being tested is to be made by means of a 12-inch (300 mm) or greater length of the appropriate type of flexible cord that has an ampacity at least equal to that of the device. The wire size and type are to be determined using the appropriate value for the device's current rating from Table 400.5(A) or 400.5(B) of the National Electrical Code, ANSI/NFPA 70.

89.5 revised May 14, 2004

89.6 The contacts of the device being tested are to be connected together by means of a mated attachment plug. For devices with the 1-15R, 5-15R, 5-20R, 6-15R and 6-20R configurations, the mating plugs shall have the configurations specified in Table 89.1. The plug is to have rigidly attached solid blades, and the terminals of the plug are to be short-circuited by means of the shortest feasible lengths of the appropriate flexible cord as described in 89.5.

89.6 revised May 14, 2004

89.7 The terminals are to be tightened to the marked torque limit or, when a tightening torque is not provided, the torque used is to be 9 in-lbf (1.0 N·m) for devices rated 15 A or less and 14 in-lbf (1.6 N·m) for other ratings.

**Table 89.1**  
**Mating plug configurations for temperature testing**

Device under test	Mating plug	No. of devices tested
1-15R	1-15P	6
5-15R	5-15P	6
5-20R	5-15P	3
	5-20P	3
6-15R	6-15P	6
6-20R	6-15P	3
	6-20P	3

89.8 Temperature readings are to be obtained by means of thermocouples consisting of 28 – 32 AWG (0.08 – 0.03 mm<sup>2</sup>) iron and constantan wires. It is a common practice to employ thermocouples consisting of 30 AWG (0.05 mm<sup>2</sup>) iron and constantan wires with a potentiometer type of indicating instrument. This equipment is to be used when a referee measurement of temperature is necessary.

89.8 revised November 16, 2007

## 90 Retention of Plugs Test (Repeated)

### 90.1 General

90.1.1 After completion of the Overload Test, Section 88, and the Temperature Test, Section 89, the contacts of a 1-15R, 5-15R, 5-20R, 6-15R or 6-20R configuration cord connector shall retain an attachment plug so that when tested as described in this section:

- a) A force greater than 3 lbf (13 N) is required to withdraw the plug, and
- b) A force of 15 lbf (67 N) is capable of withdrawing the plug.

*Exception: A cord connector that has provision for locking the plug in place after the blades have been inserted in the female contacts (such as a rotating collar) is not required to be subjected to this test*

90.1.2 A cord connector with a spring-activated latching mechanism shall be subjected to this test with its mechanism defeated. See 86.2.

**UL COPYRIGHTED MATERIAL –  
NOT AUTHORIZED FOR FURTHER REPRODUCTION OR  
DISTRIBUTION WITHOUT PERMISSION FROM UL**

## 90.2 Plug retention

90.2.1 Each of six devices is to be tested. A standard solid-blade attachment plug that has American National Standard detent holes, in accordance with Wiring Devices – Dimensional Specifications, ANSI/NEMA WD6, in rigidly mounted blades is to be fully inserted into the device. The test plugs are to have the configuration specified in Table 90.1. A pull of 3 lbf (13 N) in a direction perpendicular to the plane of the face of the cord connector and tending to withdraw the plug from the device is then to be applied to the plug for 1 minute. The displacement of the plug shall not be greater than 0.079 inch (2 mm).

**Table 90.1**  
**Mating plug configurations for plug retention**

Device under test	Mating plug	No. of devices tested
1-15R	1-15P	6
5-15R	1-15P	6
5-20R	1-15P	3
	5-20P <sup>a</sup>	3
6-15R	2-15P	6
6-20R	2-15P	3
	6-20P <sup>a</sup>	3

<sup>a</sup> Shall have the ground blade removed.

## 90.3 Plug Withdrawal

90.3.1 Each of six devices is to be tested. Following the application of the 3 lbf (13 N), the pull is to be increased to 15 lbf (67 N), using test plugs having the configuration specified in Table 90.2, and the plug shall be withdrawn by the force.

**Table 90.2**  
**Mating plug configurations for plug withdrawal**

Device under test	Mating plug <sup>a</sup>	No. of devices tested
1-15R	1-15P	6
5-15R	5-15P	6
5-20R	5-15P	3
	5-20P	3
6-15R	6-15P	6
6-20R	6-15P	3
	6-20P	3

<sup>a</sup> Shall have American National Standard detent holes in accordance with Wiring Devices – Dimensional Specifications, ANSI/NEMA WD6.

## 91 Resistance to Arcing Test

91.1 If a material is used in the construction of the face of a cord connector in a way that the material is likely to be exposed to arcing while in service, the devices that were subjected to 50 cycles of operation in the overload test described in Overload Tests, Section 88, shall perform acceptably when subjected to an additional 200 cycles of operation under the overload-test conditions following the temperature test and the repetition (if required – see 87.3) of the retention-of-plugs and gripping tests. There shall not be any indication of electrical tracking, formation of a permanent carbon conductive path or ignition of the material. The attachment plug used for this test may be changed after every 50 operations.

91.2 Alternatively one set of devices may be subjected to the 50 cycles of operation in the overload test described in Overload Tests, Section 88, followed by the temperature test on the devices and then, to determine resistance to arcing, a second, previously untested set of devices may be subjected to 250 cycles of operation under the overload-test conditions.

## 92 Latching Mechanism Tests

### 92.1 General

92.1.1 A 1-15R, 5-15R, 5-20R, 6-15R, or 6-20R cord connector employing a spring-actuated latching mechanism for locking a mated attachment plug in place after its blades have been inserted into the female contacts shall be subjected to the tests in this section.

*Exception: Cord connectors subjected to the tests described in Sections 87 – 90 with the latching mechanism defeated and found to comply are not required to be subjected to the latching mechanism tests.*

### 92.2 Cycling test

92.2.1 After completion of this test, there shall not be any damage to the cord connector, its latching mechanism, or the attachment plugs. The latching mechanism shall remain capable of functioning as intended. There shall not be any damage, arcing or dielectric breakdown during application of the test potential. The mating plug shall not pull free from the cord connector outlet during application of the test force.

92.2.2 Each of six previously untested devices is to be tested. A mating attachment plug having rigidly mounted solid blades and standard detent holes is to be inserted and fully seated into the outlet of the device under test. For devices with the 1-15R, 5-15R, 5-20R, 6-15R or 6-20R configurations, the mating plugs shall have the configurations specified in Table 92.1. The latching mechanism is to be activated to lock the plug in place. The locking means is then to be activated to release the plug and the plug is to be withdrawn from the outlet. This sequence is to be repeated for a total of 1000 cycles.

**UL COPYRIGHTED MATERIAL –  
NOT AUTHORIZED FOR FURTHER REPRODUCTION OR  
DISTRIBUTION WITHOUT PERMISSION FROM UL**

**Table 92.1**  
**Mating plug configurations for cycling testing**

Device under test	Mating plug	No. of devices tested
1-15R	1-15P	6
5-15R	1-15P	6
5-20R	1-15P	3
	5-20P	3
6-15R	6-15P	6
6-20R	6-15P	3
	6-20P	3

92.2.3 Each device is then to be subjected to a 50-60 Hz essentially sinusoidal potential equal to twice the rated voltage plus 1000 V applied between live parts of opposite polarity and between live parts and grounding or dead metal parts. The test voltage is to be increased at a uniform rate and as rapidly as is consistent with its value being correctly indicated by a voltmeter, and maintained at the test potential for 1 minute. A mating attachment plug capable of withstanding a 2500 V potential is then to be inserted into the outlet and the application of the test potential is to be repeated.

92.2.4 A mating attachment plug employing folded blades with standard detent holes is then to be inserted and fully seated in the outlet of each device under test. The latching mechanism is to be actuated to lock the plug in place. A static 30 lbf (133 N) is to be applied to the plug for 1 minute in a direction perpendicular to the plane of the face of the outlet.

### 92.3 Pull test

92.3.1 After completion of this test, there shall not be any damage to the cord connectors or the blades of the attachment plugs or other evidence of increased risk of injury or electric shock. The latching means shall remain functional. There shall not be any loosening of the plug blades or displacement between the blades at the attachment plug face, nor compression of the folded blades below the minimum allowable thickness for the configuration. The attachment plug shall be capable of being inserted into a standard mating receptacle. There shall not be any damage, arcing, or dielectric breakdown during application of the test potential.

92.3.2 Previously untested devices are to be used. With the device firmly secured in place, a mating attachment plug is to be inserted into the device and the latching mechanism activated to lock the plug in place. The mating plugs are to have the configurations shown in Table 92.2. A static 30 lbf (133 N) is to be applied to the plug for 1 minute in a direction perpendicular to the plane of the face of the outlet which tends to remove the plug from the outlet. The force is then to be removed from the plug and the latching mechanism activated to release the plug, and the plug removed from the outlet. This is to be repeated for a total of 50 cycles. Three devices are to be tested using attachment plugs with rigidly mounted solid blades with standard detent holes. Three devices are to be tested using attachment plugs with folded blades and standard detent holes.

**Table 92.2**  
**Mating plug configurations for pull testing**

Device under test	Mating plug	No. of devices tested
1-15R	1-15P	6
5-15R	1-15P	6
5-20R	1-15P	3
	5-20P	3
6-15R	6-15P	6
6-20R	6-15P	3
	6-20P	3

92.3.3 Each device is then to be subjected to a 50-60 Hz essentially sinusoidal potential equal to twice the rated voltage plus 1000 V applied between live parts of opposite polarity and between live parts and grounding or dead metal parts. The test voltage is to be increased at a uniform rate and as rapidly as is consistent with its value being correctly indicated by a voltmeter, and maintained at the test potential for 1 minute. A mating attachment plug capable of withstanding a 2500 V potential is then to be inserted into the outlet and the application of the test potential is to be repeated.

### 93 Fuseholder Temperature Test

93.1 When tested as described in this section, the temperature rise of a cord connector incorporating a fuseholder shall not exceed the following:

- a) 30°C (54°F) on the fuse clips when tested with a dummy fuse;
- b) 85°C (153°F) on the fuse clips when tested with a live fuse;
- c) 30°C (54°F) at the wiring terminals or cord connections at any time (see 93.7); and
- d) The relative thermal index of the surrounding insulating material, minus an assumed ambient of 25°C (77°F), at any time (see 93.7).

93.2 The test is to be conducted on a set of six previously untested devices. The test may be conducted with either a live fuse or a dummy fuse (see 93.6 and 93.7).

*Exception: The test is not prohibited from being conducted in conjunction with the Temperature Test, Section 89, when agreeable to all concerned.*

93.3 The cord connectors are to be wired in a series circuit as described in the Temperature Test, Section 89.

93.4 Temperatures are to be measured by means of thermocouples attached to the fuse clips, the insulating material of the device body in proximity to the fuseholder, and the wiring terminals or cord connections.

*Exception: If the wiring terminals or cord connections are not accessible for mounting thermocouples, the thermocouples are to be attached to the blades as close as possible to the face of the device.*

93.5 The test is to continue until stabilized temperatures are attained. A temperature is considered to be stabilized when three consecutive readings, taken at 5-minute intervals, indicate no further rise above the ambient temperature.

93.6 If the test is to be conducted with a live fuse, the devices are to be tested with the largest ampere-rated fuse intended for use with the device installed and subjected to a test current equal to the maximum fuse ampere rating.

93.7 If the test is to be conducted with a dummy fuse, the devices are to be subjected to a test current equal to the maximum ampere rating of the intended fuse. The dummy fuse size for devices incorporating Class CC, G, H, J, K, or R is to be as specified in the Standard for Fuseholders – Part 1: General Requirements, UL 4248-1, the Standard for Fuseholders – Part 4: Class CC, UL 4248-4, the Standard for Fuseholders – Part 5: Class G, UL 4248-5, the Standard for Fuseholders – Part 6: Class H, UL 4248-6, the Standard for Fuseholders – Part 8: Class J, UL 4248-8, the Standard for Fuseholders – Part 9: Class K, UL 4248-9, the Standard for Fuseholders – Part 11: Type C (Edison Base) and Type S Plug Fuse, UL 4248-11, the Standard for Fuseholders – Part 12: Class R, UL 4248-12, and the Standard for Fuseholders – Part 15: Class T, UL 4248-15. The dummy fuse size for devices employing miscellaneous, miniature and micro fuses is to be as indicated in Table 93.1. To represent the heating of a live fuse, 20°C (36°F) is to be added to the recorded temperature rise on the wiring terminals, cord connections, or surrounding insulating materials.

93.7 revised November 16, 2007

**Table 93.1**  
**Nominal dimensions of dummy fuses for miscellaneous, miniature and micro fuses**

Size of fuse	Dimensions		
	Outside diameter	Wall thickness	Length
5 x 20 mm (0.2 x 0.8 inches)	5 mm (0.2 inches)	1.2 mm (0.047 inches)	20 mm (0.8 inches)
1/4 x 1-1/4 inches (6.4 x 31.8 mm)	0.25 inches (6.4 mm)	0.049 inches (1.2 mm)	1-1/4 inches (31.8 mm)

93.8 The thermocouples are to consist of 28 – 32 AWG (0.08 – 0.032 mm<sup>2</sup>) iron and constantan wires. It is a common practice to employ thermocouples consisting of 30 AWG (0.05 mm<sup>2</sup>) iron and constantan wires with a potentiometer type of indicating instrument. This equipment will be used if a referee measurement of temperature is necessary.

93.8 revised November 16, 2007

**UL COPYRIGHTED MATERIAL –  
NOT AUTHORIZED FOR FURTHER REPRODUCTION OR  
DISTRIBUTION WITHOUT PERMISSION FROM UL**

## 94 Improper Insertion Test

94.1 To determine compliance with 15.2.3 and 15.2.4, a cord connector having a 1-15R configuration shall obstruct the attempted insertion of the test blades illustrated in Figure 94.1, when tested as described in 94.2 and 94.3.

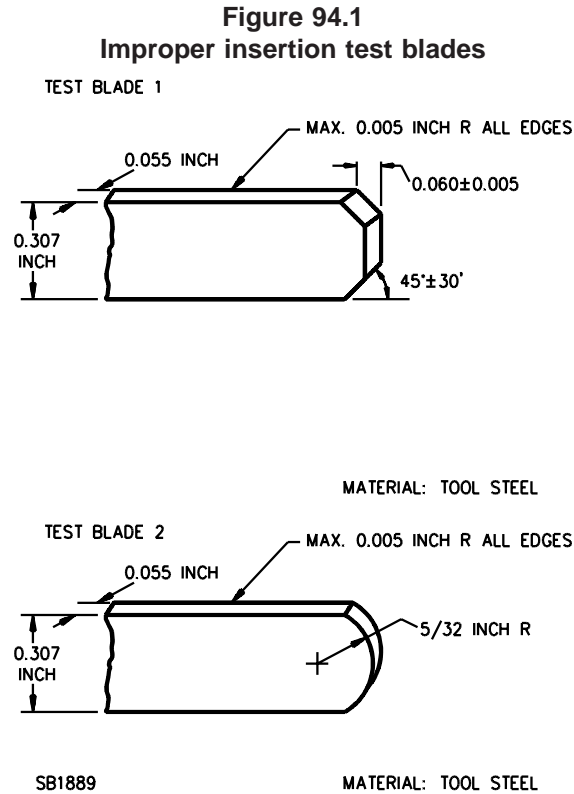

94.2 Each of 12 cord connectors is to be tested while being supported on a flat steel plate. Rigid spacing materials may be used to support a cord connector that because of its shape does not lie flat on the steel plate, provided that by doing so, pressure is not exerted against the cord connector that will influence test results. The test blades shall be supported and centered above the non-polarized contact slot of the cord connector being tested. Each contact slot of a non-polarized cord connector is to be tested separately.

94.3 Each test blade is to be inserted into the non-polarized contact slot with a force that is to be gradually increased from zero to a 35 lbf (156 N). The force is to be maintained for one minute. Six cord connectors are to be tested using test blade 1, and six using test blade 2. In each case, the test blades shall be obstructed to the extent that they do not make electrical contact with the device contact relating to the non-polarized slot.

**UL COPYRIGHTED MATERIAL –  
NOT AUTHORIZED FOR FURTHER REPRODUCTION OR  
DISTRIBUTION WITHOUT PERMISSION FROM UL**



## 95 Potential Drop in Grounding Connections Test

95.1 A pressure connection that is secured by a means other than riveting, bolting, or welding in the grounding path of a cord connector grounding device (see 2.14) shall not show a drop in potential of more than 30 mV from the grounding contact or blade to the grounding terminal while a direct current equal to the maximum rated current of the device is flowing in the grounding path.

## 96 Integrity of Assembly Test

### 96.1 General

96.1.1 A cord connector shall not experience breakage or separation of the device body, detachment of any cord conductor, or any other damage that could increase the risk of fire or electric shock, when tested as described in this section.

*Exception No. 1: A device intended for use with a strain-relief knot as described in 13.3 is not required to be subjected to this test.*

*Exception No. 2: A strain-relief that consists of a cord clamp located outside the wiring compartment and that is tightened by one or more screws is not required to be subjected to this test.*

*Exception No. 3: A cord connector employing pin-type terminals instead shall be subjected to the Strain Relief Test, Section 101.*

*Exception No. 4: A Hospital Grade cord connector shall instead be subjected to the Strain Relief Test, Section SD19.*

96.1.2 A field-wired device is to be wired in accordance with the manufacturer's instructions using 12 inch (305 mm) lengths of the sizes and types of flexible cord chosen to represent the range of cords intended for use with the device. See Reference No. 5 to Table 163.3.

96.1.3 The device is to be anchored securely and the cord is to be pulled steadily as follows:

- a) 30 lbf (133 N) for a cord with 18 AWG (0.82 mm<sup>2</sup>) or larger conductors, and
- b) 20 lbf (89 N) for a cord with conductors smaller than 18 AWG (0.82 mm<sup>2</sup>),

for 1 minute in the direction perpendicular to the plane of the cord entrance.

96.1.3 revised November 16, 2007

## 96.2 Self-hinged cord connectors

96.2.1 If the cord connector employs a self-hinge that is relied upon to hold the flexible cord in place, the tests described in 96.1.1 – 96.1.3 are to be repeated with the hinges cut. If unacceptable results are obtained, a separate set of six devices is to be subjected to the Self-Hinge Flexing Test described in Section 97.

## 97 Self-Hinge Flexing Test

97.1 A self-hinge that is relied upon to maintain the integrity of the enclosure or strain relief after a cord connector is assembled shall not break, crack or experience other damage as a result of this test.

97.2 Three groups of six devices each shall be tested as follows:

- a) Group 1 – As received;
- b) Group 2 – Oven conditioned for 168 hours at 100°C (212°F); and
- c) Group 3 – Cold conditioned for 2 hours at -10°C (14°F) and allowed to return to room temperature.

97.3 The hinge of each device shall be completely opened and closed for 100 cycles of operation.

Pin-Type Terminals

## 98 General

98.1 In addition to the general performance requirements for cord connectors, a cord connector with pin-type terminals shall comply with the requirements in Sections 99 – 103.

## 99 Assembly Test

99.1 A cord connector with pin-type terminals shall be able to be readily assembled to the flexible cords with which it is intended to be used.

99.2 The device shall be assembled and tested with each of the sizes and types of flexible cords that it will physically accommodate following the instructions provided by the manufacturer. Proper assembly shall be determined by visual examination and compliance with the tests described in Sections 87 – 103.

*Exception: The device is not required to be assembled and tested with those cord types and sizes excluded by the marking specified in item (c) of Reference No. 6 of Table 163.3.*

## 100 Temperature Test

100.1 The temperature rise shall not be more than 30°C (54°F) when a cord connector with pin-type terminals is carrying the current corresponding to the ampacity of the size cord that the device is intended to accommodate.

100.2 The test is to be conducted on devices assembled to flexible cords selected as follows:

- a) For a cord connector intended to be used with 18 AWG (0.82 mm<sup>2</sup>) Types SP-1 and SPT-1 flexible cord, two sets of six devices each are to be assembled. One set is to be assembled using 18 AWG (0.82 mm<sup>2</sup>) polyvinyl chloride insulated Type SPT-1 cord having a maximum width of 0.205 inch (5.21 mm) and a maximum overall thickness of 0.110 inch (2.79 mm). The second set is to be assembled using 18 AWG (0.82 mm<sup>2</sup>) polyvinyl chloride insulated Type SPT-1 cord having a minimum overall width of 0.210 inch (5.33 mm).
- b) For a cord connector intended for use with other types of flexible cord, consideration is to be given to the need for testing different types of cords and the effects of variations on insulation material and thickness for each type of flexible cord.
- c) For a cord connector intended for use with more than one size of flexible cord, the temperature test is to be repeated for each size wire.

100.2 revised November 16, 2007

100.3 Each set is to be tested for temperature rise following assembly. Thermocouples are to be attached to the male blades of an attachment plug inserted in the outlet of the cord connector, as close as possible to the male face of the attachment plug. The assemblies are to be tested for 15 days without interruption. The device temperature is to be measured at the end of each working day.

100.4 Following the completion of this test, three assemblies using each of the flexible cord sizes and types specified in 100.2 are to be selected and subjected to the Dielectric Voltage-Withstand Test described in Section 103.

## 101 Strain Relief Test

101.1 When assembled to the intended flexible cord, a cord connector with pin-type terminals shall withstand the straight pull described in this section without detachment of any cord conductor or any other evidence of damage that increases the risk of fire or electric shock.

101.2 The test is to be conducted on devices assembled to flexible cords selected as follows:

- a) For a cord connector intended to be used with 18 AWG (0.82 mm<sup>2</sup>) Types SP-1 and SPT-1 flexible cord, two sets of six devices each are to be assembled using the smaller of the two cords indicated in 100.2.
- b) When cords other than 18 AWG (0.82 mm<sup>2</sup>) Types SP-1 and SPT-1 are to be used, device assemblies representing each size and type cord are to be tested. Consideration is to be given to the effects of anticipated variations in cord insulation material and thickness in selecting cords for the tests. Two sets with a minimum of three assemblies are to be tested using each representative size and type cord.

101.2 revised November 16, 2007

**UL COPYRIGHTED MATERIAL –  
NOT AUTHORIZED FOR FURTHER REPRODUCTION OR  
DISTRIBUTION WITHOUT PERMISSION FROM UL**

101.3 One set of devices for each cord size and type is to be subjected to the test described in 101.4 following assembly in the as-received condition. The second set is to be tested after being conditioned in a full-draft air-circulating oven for 30 days at 67.0°C (152.6°F).

101.4 While the cord connector is securely supported by the body, a pull is to be applied to the flexible cord for 1 minute of either:

- a) 30 lbf (133 N) when the conductors are 18 AWG (0.82 mm<sup>2</sup>) or larger, or
- b) 20 lbf (89 N) when the conductors are smaller than 18 AWG (0.82 mm<sup>2</sup>).

The direction of the force is to be perpendicular to the plane of the cord entrance.

101.4 revised November 16, 2007

## 102 Fault Current Test

102.1 When assembled to the intended flexible cord, a cord connector with pin-type terminals shall withstand the applied fault current without ignition of the cotton or cord insulation. The circuit breaker shall operate when the test circuit is closed.

102.2 The test is to be conducted on devices assembled to flexible cords selected as follows:

- a) For a cord connector intended to be used with 18 AWG (0.82 mm<sup>2</sup>) Types SP-1 and SPT-1 flexible cord, three sets of two devices each are to be tested using the larger of the two flexible cords described in 100.2.
- b) For a cord connector intended to be used with other cord sizes and types, device assemblies representing each size and type of cord are to be tested. Consideration is to be given to the effects of variations in cord insulation material and thickness in selecting cords for the tests. Three sets of two devices each are to be tested using each representative size and type of cord.

102.2 revised November 16, 2007

102.3 The cord connectors are to be assembled to a 2-ft (0.6 m) length of each size and type of flexible cords wired at one end to an attachment plug having screw terminals. A second attachment plug having screw terminals shorted by a 12 AWG (3.3 mm<sup>2</sup>) wire is to be plugged into the cord connector. The assemblies are to be tested as follows:

- a) The first set is to be subjected to the test described in 102.4 following assembly in the as-received condition.
- b) The second set is to be subjected to the test described in 102.4 after being subjected to a 15 lbf (67 N) strain relief test for 1 minute.
- c) The third set is to be subjected to the test described in 102.4 after being conditioned in an oven at 67.0°C (152.6°F) for 30 days.

102.3 revised November 16, 2007

102.4 A standard screw terminal receptacle of the 5-15R configuration (2-pole, 3-wire, 15A, 125V) is to be wired in a circuit capable of delivering 1000 A rms at 125 V when the system is short circuited at the testing terminals. The receptacle is to be wired to the testing terminals by 4 ft (1.2 m) of 12 AWG (3.3 mm<sup>2</sup>) wire. A thermal-type 20 A circuit breaker is to be connected between the receptacle and the testing terminals. The circuit breaker is to be calibrated and found to meet the calibration requirements for circuit breakers. Cotton is to be placed around the cord connector being tested. The male blades of the attachment plug at the opposite end of the assembly are to be inserted into the contacts of the receptacle and the test circuit is to be closed by means of an external switching device.

102.4 revised November 16, 2007

No Text on This Page

***UL COPYRIGHTED MATERIAL –  
NOT AUTHORIZED FOR FURTHER REPRODUCTION OR  
DISTRIBUTION WITHOUT PERMISSION FROM UL***

### 103 Dielectric Voltage-Withstand Test

103.1 The assembly of a cord and cord connector with pin-type terminals shall be capable of withstanding without breakdown, for a period of 1 minute, the application of a 60 Hz essentially sinusoidal potential of 1250 V between the two conductors of the flexible cord. Three assemblies are to be selected from the temperature test specified in Temperature Test, Section 100.

103.2 The test potential is to be supplied from a 500 V-A or larger capacity testing transformer whose output is essentially sinusoidal and can be varied. The applied potential is to be increased from zero until the required test voltage is reached, and is to be held at that voltage for a period of 1 minute. The increase in the applied potential is to be at uniform rate and as rapid as is consistent with its value being correctly indicated by the voltmeter.

### RECEPTACLES

All Devices

### 104 General

104.1 The performance of a receptacle is to be investigated by means of the applicable tests described in Sections 55 – 64 and 105 – 137 as specified in Table 54.4. For Hospital Grade receptacles, see also General, Section SD20 of Hospital Grade Devices, Supplement SD. For self-contained receptacles, see also General, Section 138.

104.2 Flush or self-contained receptacles having a 5-15R, 5-20R, 6-15R, or 6-20R configuration shall be subjected to the series of tests described in Sections 105 – 109 and other receptacle types to Sections 110 – 114 along with other additional sections as indicated in Table 54.4. The Retention of Plugs Test, Section 110, and the Retention of Plugs Test (Repeated), Section 113, is only required for receptacles having a 1-15R, 5-15R, 5-20R, 6-15R or 6-20R configuration and not of the flush or self-contained type.

104.2 revised March 15, 2006

### 105 Retention of Blades Test

105.1 A flush or self-contained receptacle having a 5-15R, 5-20R, 6-15R, or 6-20R configuration shall be subjected to the retention of blades test described in this Section.

*Exception: A receptacle having a 1-15R, 5-15R, 5-20R, 6-15R, or 6-20R configuration and not of the flush or self-contained type shall instead be subjected to the Retention of Plugs Test, Section 110.*

105.1 revised October 23, 2002

105.2 Receptacles having the break-off tab, when provided, removed from one nonidentified terminal are to be subjected to ten conditioning cycles of manual insertion and withdrawal of a standard gauge, see Figure 105.1. Each of six devices is to be tested. The gauge is to be configured as outlined in Table 105.1. The force applied to insert the gauge for any of the conditioning cycles is not to exceed 40 lbf (178 N). The gauge is to have the dimensions indicated in Figure 105.1 but is not to have holes in the outer ends of the blades.

**UL COPYRIGHTED MATERIAL –  
NOT AUTHORIZED FOR FURTHER REPRODUCTION OR  
DISTRIBUTION WITHOUT PERMISSION FROM UL**

**Table 105.1**  
**Test gauge configurations for conditioning**

Device under test	Test gauge	No. of devices tested
5-15R	5-15P	6
5-20R	5-15P	3
	5-20P	3
6-15R	6-15P	6
6-20R	6-15P	3
	6-20P	3

105.3 The standard gauge is to be configured as shown in Table 105.2 using the line blades without holes and with the grounding blade removed. The gauge is then to be inserted in the receptacle and a static 3 lbf (13.3 N) (including the weight of the gauge), which tends to remove the gauge from the receptacle, is to be applied for a period of 1 minute in a direction normal to the plane of the face of the receptacle. There shall not be more than 0.079 inch (2 mm) displacement of the gauge.

**Table 105.2**  
**Test gauge configurations for retention testing**

Table 105.2 revised March 15, 2006

Device under test	Test gauge	No. of devices tested
5-15R	1-15P or 5-15P <sup>a</sup>	6
5-20R	1-15P or 5-15P <sup>a</sup>	3
	5-20P <sup>a</sup>	3
6-15R	2-15P or 6-15P <sup>a</sup>	6
6-20R	2-15P or 6-15P <sup>a</sup>	3
	2-20P or 6-20P <sup>a</sup>	3

<sup>a</sup> Test gauge having grounding blade removed.

105.4 The standard gauge is to be configured as shown in Table 105.3 using the line blades with holes in the end and with the grounding blade in place. The gauge is then to be inserted in the receptacle and a force applied in a direction normal to the plane of the face of the receptacle that tends to remove the gauge. The static force required to withdraw the gauge shall not exceed 15 lbf (67 N) (including the weight of the gauge).



**Table 105.3**  
**Test gauge configurations for withdrawal testing**

Device under test	Test gauge	No. of devices tested
5-15R	5-15P	6
5-20R	5-15P	3
	5-20P	3
6-15R	6-15P	6
6-20R	6-15P	3
	6-20P	3

105.5 Each of the line contacts of the receptacles is to be tested using the test blade illustrated in Figure 105.2. Each line contact shall be capable of withstanding for 1 minute a static 0.5 lbf (2.2 N) applied to the test blade in a direction normal to the plane of the face of the specimen and in a direction that tends to remove the test blade, when the test blade is fully inserted in the contact opening. There shall not be more than 0.079 inch (2 mm) displacement of the test blade.

**Figure 105.1  
Test gauge**

Figure 105.1 revised November 16, 2007

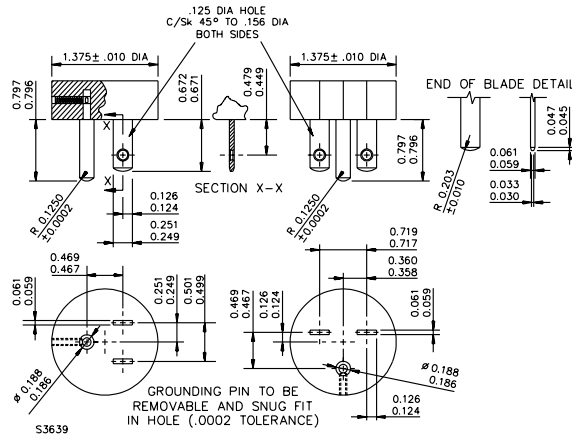

**NOTES**

- 1) Blades shall be made of tool steel, Rockwell Hardness C58 to C60.
- 2) All sharp edges shall be removed to a radius of 0.016 to 0.020 inch. Ends of all flat blades bevelled as shown in the end of blade detail.
- 3) Blade surfaces shall not exceed a 32 microinch finish grind in a direction perpendicular to the major axis. Finish is to be determined visually using a comparative method and 10 X optical magnification.
- 4) All blade hole positions are located on the centerline of the blades.
- 5) R designates radius. All dimensions are in inches.
- 6) Flat blade positions shall be modified to suit configurations 5-20 and 6-20.

Inch	mm	Inch	mm	Inch	mm
0.0002	0.005	0.125	3.18	0.467	11.8
0.001	0.025	0.126	3.20	0.469	11.91
0.002	0.051	0.156	3.96	0.479	12.17
0.010	0.254	0.186	4.72	0.499	12.67
0.016	0.4	0.188	4.78	0.501	12.73
0.020	0.5	0.203	5.156	0.671	17.04
0.031	0.79	0.249	6.33	0.672	17.07
0.045	1.14	0.251	6.37	0.717	18.21
0.047	1.19	0.358	9.09	0.719	18.26
0.059	1.50	0.360	9.14	0.796	20.22
0.061	1.55	0.449	11.40	0.797	20.24
0.124	3.15	0.461	11.7		
	microinch			32	
	nm			813	

**UL COPYRIGHTED MATERIAL –  
NOT AUTHORIZED FOR FURTHER REPRODUCTION OR  
DISTRIBUTION WITHOUT PERMISSION FROM UL**

**Figure 105.2  
Test blade**

Figure 105.2 revised March 15, 2006

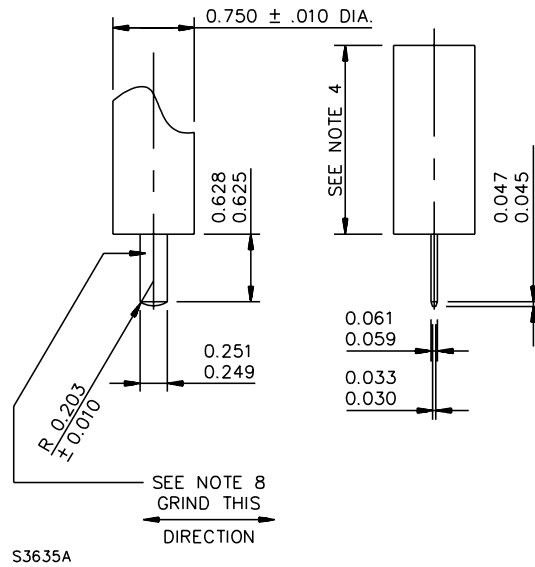

Inch	(mm)	Inch	(mm)
0.010	0.25	0.061	1.55
0.030	0.76	0.203	5.16
0.033	0.84	0.249	6.33
0.045	1.14	0.251	6.37
0.047	1.19	0.625	15.88
0.059	1.50	0.628	15.95
		0.750	19.05

NOTES

- 1) Dimensions are in inches.
- 2) Metric equivalents are given for general information only and are based upon 1.00 inch = 25.4 mm.
- 3) Axis of blade and axis on holder must have a combined concentricity and axial alignment tolerance of 0.006 inch (0.15 mm) maximum T.I.R.
- 4) Length to suit total tool weight of 0.50 pounds.
- 5) The blade is to be fastened to the handle in a rigid manner.
- 6) Sharp edges shall be removed to a maximum radius of 0.015 inch (0.38 mm).
- 7) The blade shall be of steel having a Rockwell Hardness of C58 to C60. The handle shall be cold rolled steel.
- 8) The blade surfaces shall not exceed a 32 microinch finish grind in a direction perpendicular to the major axis. Finish is to be determined visually using a comparative method and 10 X optical magnification.

**UL COPYRIGHTED MATERIAL –  
NOT AUTHORIZED FOR FURTHER REPRODUCTION OR  
DISTRIBUTION WITHOUT PERMISSION FROM UL**

No Text on This Page

***UL COPYRIGHTED MATERIAL –  
NOT AUTHORIZED FOR FURTHER REPRODUCTION OR  
DISTRIBUTION WITHOUT PERMISSION FROM UL***

## 106 Overload Test

106.1 A flush or self-contained receptacle having a 5-15R, 5-20R, 6-15R, or 6-20R configuration shall be subjected to the overload test described in this Section. There shall not be any electrical or mechanical failure of the device nor pitting or burning of the contacts that would affect the intended function.

*Exception: All other receptacles shall instead be subjected to the Overload Test, Section 111.*

106.2 The test is to be conducted using direct current with a resistive load. If a receptacle employs electronic components or if the receptacle is a tamper-resistant type with internal switching contacts, the test is to be conducted while bypassing those components.

106.3 Each of six receptacles is to be tested, by machine or manually, as outlined in 106.4 and 106.5, by inserting and withdrawing an attachment plug of the configuration specified in Table 106.1 having rigidly secured solid blades that are connected through a flexible cord to a suitable load. A grounding type attachment plug is to be used and the grounding blade of the attachment plug is to be connected to the grounding contact of the receptacle under test. The grounding contact of the receptacle under test is to be connected through a fuse to the ground. The receptacle is to be caused to make and break 150 percent of rated current for 100 cycles of operation at a rate not faster than 10 cycles per minute. The blade of the attachment plug is to mate with the contact of the receptacle for not more than 1 second during each cycle. The attachment plug used for this test is able to be changed after 50 cycles. In the case of a duplex receptacle, only one set of contacts of each receptacle is to be overloaded; half of the receptacles are to be tested at one contact position and half at the other contact position.

**Table 106.1**  
**Mating plug configurations for overload testing**

Device under test	Mating plug	No. of devices tested
5-15R	5-15P	6
5-20R	5-15P	3
	5-20P	3
6-15R	6-15P	6
6-20R	6-15P	3
	6-20P	3

106.4 If conducted by machine, it is to withdraw and insert an unrestricted attachment plug with an average velocity of  $30 \pm 3$  inches/s ( $760 \pm 75$  mm/s) in each direction during a 2-1/2 inch (64 mm) stroke measured from the fully inserted position. The velocity is to be determined without the receptacle installed on the machine in order to eliminate restrictions on the attachment plug motion.

106.5 In the event of failures during machine testing, referee tests may be conducted manually under conditions similar to those described in 106.4.

106.6 The open circuit voltage of the test circuit shall not exceed 105 percent of the rated voltage and the closed circuit voltage shall not be less than 95 percent of the rated voltage. At the option of the manufacturer the open circuit voltage may exceed 105 percent of the rated voltage.

106.7 Neither the blades nor the contacts are to be adjusted, lubricated, or conditioned, other than as required by Retention of Blades Test, Section 105, before or during the test.

106.8 The receptacle is to be mounted and wired to represent service conditions. If the receptacle is intended for use with a face plate or the like, it is to be mounted with a suitable metal plate as in service. The metal parts that are intended to be grounded shall be connected through a fuse to ground. The frame (yoke) and enclosure, if any, are to be positive with respect to the nearest arcing point of the receptacle.

106.9 The fuse in the grounding circuit is to be a 15 A-fuse. The fuses in the test circuit are to have the next higher standard fuse rating than the value of the test current. If either the line fuse or the grounding fuse opens during the test, the results are not acceptable.

106.9 revised November 16, 2007

## 107 Temperature Test

107.1 The contact temperature rise of a flush or self-contained receptacle having a 5-15R, 5-20R, 6-15R, or 6-20R configuration shall not be more than 30°C (54°F) when the receptacle is carrying its maximum rated current.

*Exception: All other receptacles shall instead be subjected to the Temperature Test, Section 112.*

107.2 Each receptacle provided with means for through-wiring on a branch circuit is also to be subjected to a terminal temperature test at a current of 20 A. The temperature rise on the terminals shall not be more than 30°C (54°F), except as noted in 107.9.

*Exception No. 1: Self-contained receptacles are not required to be subjected to a terminal temperature test.*

*Exception No. 2: Devices employing "Push-In" terminals are to be subjected to the tests in Temperature Test, Push-In Terminals, Section 130.*

*Exception No. 3: If a device employs both "Push-In" terminals and either pressure-wire, clamp, set screw or wire-binding screw terminals, the "Push-In" terminals are to be subjected to the tests in Temperature Test, Push-In Terminals, Section 130. The remaining terminals are to be subjected to the terminal temperature test in this section. Such receptacles shall be marked to identify the intended use of each terminal in accordance with Reference No. 26 of Table 163.4.*

107.3 For receptacles of configurations 5-20R and 6-20R the contact temperature and terminal temperature tests are to be combined. The receptacle is to be wired with 12 AWG (3.3 mm<sup>2</sup>) solid or stranded copper building wire.

107.3 revised November 16, 2007

107.4 For receptacles of configuration 5-15R or 6-15R intended for through-wiring and not represented by otherwise similar receptacles of configuration 5-20R or 6-20R, the contact temperature and terminal temperature tests are to be conducted separately. These 15-A configuration receptacles are to be wired with 14 AWG (2.1 mm<sup>2</sup>) solid or stranded copper building wire for the contact temperature test which is to be conducted at a current of 15 A. The same receptacles are to be rewired with 12 AWG (3.3 mm<sup>2</sup>) solid or stranded copper building wire for the terminal temperature test.

107.4 revised November 16, 2007

107.5 For receptacles of configurations 5-15R and 6-15R not intended for through-wiring, the contact temperature and terminal temperature tests are to be combined. The receptacle is to be wired with 14 AWG (2.1 mm<sup>2</sup>) solid or stranded copper building wire.

107.5 revised November 16, 2007

107.6 The temperature measurement mentioned in 107.1 is to be taken at points as close to the face of the receptacle as possible on the male blades of an attachment plug inserted in the outlet. The temperature measurement mentioned in 107.2 is to be made on the wiring terminals of the receptacle if they are accessible for the mounting of thermocouples.

107.7 When testing receptacles with wire leads that are intended for through-wiring on a branch circuit or with terminals that are inaccessible for mounting thermocouples, the terminal temperature is to be measured on the conductor as close as possible to the entry (exit) of the conductor to (from) the receptacle.

107.8 When testing receptacles with wire binding screws or screw actuated clamp type terminations, the terminal temperature is to be measured on the terminations in a manner such that the thermocouple does not interfere with the termination.

107.9 When conducting the terminal temperature test on a receptacle provided with break-off tabs the test current is to pass through one break-off tab (the tab between the identified terminals of a 125 V receptacle) and a thermocouple affixed to the tab shall not indicate a temperature rise at the tab of more than 40°C (72°F).

107.10 The temperature test(s) are to be conducted following the overload test on six receptacles and are to continue until stabilized temperatures are attained. A temperature is considered to be stabilized when three consecutive readings, taken at 5-minute intervals, indicate no further rise above the ambient temperature. The contact temperatures are to be measured at the contacts previously subjected to the overload test.

107.11 The overloaded contacts of individual receptacles are to be connected together by means of a shorted attachment plug of the configuration shown in Table 107.1. A standard solid blade attachment plug is to be used. The terminals of the plug are to be short-circuited by means of the shortest feasible length of wire that has an ampacity at least equal to that of the receptacle. The shorting wire is able to be soldered to the plug terminals in order to minimize the generation of heat from sources other than the contacts.

**Table 107.1**  
**Mating plug configurations for temperature testing**

Device under test	Mating plug	No. of devices tested
5-15R	5-15P	6
5-20R	5-15P	3
	5-20P	3
6-15R	6-15P	6
6-20R	6-15P	3
	6-20P	3

107.12 The receptacles under test are to be connected in series in the test circuit with building wire as specified in 107.4 or 107.5 using lengths of no less than 20 inches (500 mm). The receptacles are to be connected in a manner such that the current path enters the receptacle at the terminal furthest from an overloaded contact (if more than one terminal per contact is provided), passes through the break-off tab (if a break-off tab is provided), passes through one overloaded contact, the shorted plug and the other overloaded contact, and then exits the receptacle through the terminal closest to the other overloaded contact.

107.13 Wire binding terminal screws and screw actuated clamp type terminals on the receptacle under test are to be tightened using a torque of 9 in-lbf (1.0 N-m) for receptacles wired with 14 AWG (2.1 mm<sup>2</sup>) conductor and 14 in-lbf (1.6 N-m) for receptacles wired with 12 AWG (3.3 mm<sup>2</sup>) conductor.

107.13 revised November 16, 2007

### **108 Retention of Blades Test (Repeated)**

108.1 Following the temperature test(s) the overloaded contacts of a flush or self-contained receptacle having a 5-15R, 5-20R, 6-15R, or 6-20R configuration are to be subjected to a repeated Retention of Blades Test in accordance with Section 105.

*Exception: A receptacle having a 1-15R, 5-15R, 5-20R, 6-15R, or 6-20R configuration and not of the flush or self-contained type shall instead be subjected to a repeated Retention of Plugs Test in accordance with Section 110.*

108.1 revised October 23, 2002



## 109 Resistance to Arcing Test

109.1 If an insulating material is used in the construction of the face of a flush or self-contained receptacle having a 5-15R, 5-20R, 6-15R, or 6-20R configuration in a way that the material is likely to be exposed to arcing while in service, the outlets that were subjected to 100 cycles of operation in the Overload Test described in Section 106 shall perform acceptably when subjected to an additional 150 cycles of operation under the overload test conditions following the temperature test and the repeated retention of blades test.

*Exception: A receptacle having a 1-15R, 5-15R, 5-20R, 6-15R, or 6-20R configuration and not of the flush or self-contained type shall instead be subjected to the Resistance to Arcing Test, Section 114.*

109.2 Alternatively, one set of receptacles may be subjected to the 100 cycles of operation in the Overload Test described in Section 106, followed by the temperature test and repeated retention of blades test on the receptacles and then, to determine resistance to arcing, a second, previously untested set of receptacles may be subjected to 250 cycles of operation under the overload-test conditions.

No Text on This Page

Document Was Downloaded By jianxiong chen For Use By KAI HUA (FOSHAN SHUNDE) ELECTRIC APPLIANCE CO LTD 22381 : 5/8/2008 - 10:34 AM

***UL COPYRIGHTED MATERIAL –  
NOT AUTHORIZED FOR FURTHER REPRODUCTION OR  
DISTRIBUTION WITHOUT PERMISSION FROM UL***

109.3 The attachment plug used for this test may be changed after every 50 operations. There shall not be any sustained flaming of the material in excess of five seconds duration. There shall not be any electrical tracking or the formation of a permanent carbon conductive path which results in a dielectric breakdown, as determined by the application of a 60 Hz essentially sinusoidal potential of 1500 V applied for one minute between live parts of opposite polarity and between live parts and dead metal parts.

### 110 Retention of Plugs Test

110.1 The contacts of a 1-15R, 5-15R, 5-20R, 6-15R or 6-20R configuration receptacle, other than the flush or self-contained type, shall retain an attachment plug so that a force greater than 3 lbf (13 N) is required to withdraw the plug when tested as described in this section.

*Exception: A receptacle that has provision for locking the plug in place after the blades have been inserted in the female contacts (such as a rotating collar) is not required to be subjected to this test.*

110.2 Each of six devices is to be subjected to ten conditioning cycles of insertion and withdrawal of a standard solid-blade attachment plug that has American National Standard detent holes in accordance with Wiring Devices – Dimensional Specifications, ANSI/NEMA WD6, in rigidly mounted blades, following which the plug is to be fully reinserted into the device. The mating plugs are to have the configuration indicated in Table 110.1. A pull of 3 lbf (13 N) in a direction perpendicular to the plane of the face of the receptacle and tending to withdraw the plug from the device is then to be applied to the plug for 1 minute. The displacement of the plug shall not be greater than 0.079 inch (2 mm).

**Table 110.1**  
**Mating plug configurations for plug retention**

Device under test	Mating plug	No. of devices tested
1-15R	1-15P	6
5-15R	1-15P	6
5-20R	1-15P	3
	5-20P <sup>a</sup>	3
6-15R	2-15P	6
6-20R	2-15P	3
	6-20P <sup>a</sup>	3

<sup>a</sup> Shall have the ground blade removed.

## 111 Overload Test

### 111.1 General

111.1.1 A receptacle shall be capable of performing acceptably when subjected to the current overload test as described in this section. A receptacle additionally rated in horsepower shall also be capable of performing acceptably when subjected to the horsepower overload test as described in this section. In either case, there shall not be any electrical or mechanical failure of the device, opening of a line or grounding fuse, welding of the contacts, nor burning or pitting of the contacts that would affect the intended function of the device.

*Exception No. 1: A receptacle that is intended for disconnecting use only and not for current interruption, is not required to be subjected to this test. See also 162.6.*

*Exception No. 2: Either the current overload test or horsepower overload test may be omitted if it is obvious that one test is fully represented by the other.*

111.1.2 The device is to be mounted and wired to represent service conditions. If the device is intended for use with a face plate or the like, it is to be mounted with a metal plate as in service. If the device is rated at 250 V or less, the metal plate is to be connected through a fuse to ground, to the grounded conductor of the test circuit, or to a circuit conductor that differs from at least 125 V in potential from one or more of the remaining conductors in the circuit. If the device is rated more than 250 V, the plate is to be connected similarly to a circuit conductor that differs by at least the rated potential from one or more of the remaining conductors in the circuit. The frame (yoke) and enclosure, if any, are to be electrically positive with respect to the nearest arcing point of the device.

111.1.3 The fuse in the grounding conductor is to be:

- a) A 15 A fuse if the device being tested is rated 30 A or less; or
- b) A 30 A fuse if the device being tested is rated more than 30 A.

The fuse in the test circuit is to have the next higher standard fuse rating than the value of the test current.

111.1.4 The potential of the test circuit is to be from 95 to 105 percent of the rating of the device in volts. Devices rated 250 V are to be tested on circuits with a potential to ground of 125 V. Receptacles having other voltage ratings are to be tested on circuits involving full rated potential to ground, except for multi-phase rated devices which are to be tested on circuits consistent with their voltage ratings (for example, a 120/208 V, 3-phase device, is to be tested on a circuit involving 120 V to ground). Testing using a 60 Hz supply voltage may represent testing using a higher frequency supply voltage not exceeding 400 Hz.

111.1.5 Each of six devices is to be tested by machine or manually by inserting and withdrawing an attachment plug having rigidly secured solid blades that are connected through a flexible cord to a load. For devices with a 1-15R, 5-15R, 5-20R, 6-15R or 6-20R configuration, the mating plugs shall have the configurations specified in Table 111.1. When an equipment-grounding connection is provided in the device being tested, a grounding-type attachment plug is to be used and the grounding blade of the plug connected to the grounding contact of the device being tested. The grounding contact is then to be grounded through a fuse as specified in 111.1.3.

**UL COPYRIGHTED MATERIAL –  
NOT AUTHORIZED FOR FURTHER REPRODUCTION OR  
DISTRIBUTION WITHOUT PERMISSION FROM UL**

**Table 111.1**  
**Mating plug configurations for overload testing**

Device under test	Mating plug	No. of devices tested
1-15R	1-15P	6
5-15R	5-15P	6
5-20R	5-15P	3
	5-20P	3
6-15R	6-15P	6
6-20R	6-15P	3
	6-20P	3

111.1.6 For a device rated 20 A or less, the test machine is to withdraw and insert an unrestricted attachment plug with an average velocity of  $30 \pm 3$  inches/s ( $760 \pm 75$  mm/s) in each direction during a 2-1/2 inch (64 mm) stroke measured from the fully inserted position. The velocity is to be determined without the outlet device installed on the machine to eliminate restrictions on the plug motion.

111.1.7 For a device rated more than 20 A the test machine unrestricted plug velocity and stroke length are to be adjusted as necessary to obtain the maximum mating time required in 111.1.8.

111.1.8 The device is then to make and break the required test load for 50 cycles of operation at a rate no faster than 10 cycles per minute. The blade of the attachment plug is to mate with the female contact of the device for no more than 1 second for straight-blade devices, and 3 seconds for locking devices during each cycle. For locking devices, each cycle of operation is to include rotation of the test plug to the full lock position after insertion, and back to the unlocked position before withdrawal.

111.1.9 Blades or contacts are not to be adjusted, lubricated, or otherwise conditioned before or during either test. The attachment plug used for either test may be changed after 50 cycles.

111.1.10 In the event that unacceptable results are obtained in the machine testing described in 111.1.6 or 111.1.7, referee tests may be conducted manually under conditions similar to those described in 111.1.6 or 111.1.7.

## 111.2 Current overload test

111.2.1 The test current shall be 150 percent of the rated current of the device. For devices with standard configurations rated 125 V, 250 V, or 125/250 V illustrated in Wiring Devices – Dimensional Specifications, ANSI/NEMA WD6, the test is to be conducted on direct current. All other devices with standard configurations denoted as "AC" or "3-phase" are to be tested on alternating current. For devices with nonstandard configurations, the test is to be conducted using direct current with a resistive load, except that alternating current is to be used if the device is rated for alternating current only. Whenever alternating current is used for the test, the power factor of the load is to be from 0.75 to 0.80.

111.2.2 Testing of a device that has a dual voltage rating and a dual current rating is to be performed at the maximum rating in volts and with 150 percent of the rated current that corresponds to the maximum voltage rating.

*Exception: A test on alternating current may be waived if equivalent results have been obtained from a direct potential that is equal to or greater than the alternating-potential rating.*

### 111.3 Horsepower overload test

111.3.1 If a separate horsepower overload test is conducted, the tests for the horsepower ratings are to be conducted on separate sets of previously untested devices. For devices with a phase to phase (L-L) and phase to neutral (L-N) horsepower rating, the test for each rating is to be conducted on a separate set of previously untested devices.

111.3.2 For devices with standard configurations illustrated in Wiring Devices – Dimensional Specifications, ANSI/NEMA WD6, the test current corresponding to the AC horsepower rating shall be as specified in Table 111.2. The load for an alternating current horsepower rating is to have a power factor of 0.40 – 0.50. For devices with a voltage rating of 250 volts, the overload test for the phase to phase horsepower rating is to be conducted at both 208 V ac and 250 V ac. A single test may be conducted at 250 V ac and at the test current for 208 V ac, if agreeable to all parties.

*Exception No. 1: Devices with a L9-20R, L9-30R, L13-30R, L17-30R, L20-20R, L20-30R, L23-20R, L23-30R, SS1-50R, SS2-50R, TT-R, ML-1R, ML-2R, or ML-3R configuration, or one of the configurations illustrated in Figures C3.8 – C3.12 do not have assigned horsepower ratings and are not required to be subjected to the horsepower overload test.*

*Exception No. 2: Appliance, equipment or fixture outlets do not have assigned horsepower ratings and are not to be subjected to the horsepower overload test.*

111.3.3 For all devices with nonstandard configurations, the test current corresponding to the horsepower rating is to be as specified in the Standard for General-Use Snap Switches, UL 20, for a device having an alternating-current rating of 2 horsepower or less and as specified in the Standard for Enclosed and Dead-Front Switches, UL 98, for a device having an alternating-current rating of more than 2 horsepower. The load for an alternating current horsepower rating is to have a power factor of 0.40 – 0.50.

**Table 111.2**  
**Test current (locked rotor amperes) for horsepower rated NEMA configuration receptacles**

NEMA configuration	AC HP rating <sup>a</sup>	LRA (amperes)	AC test voltage
1-15R	0.5	58.8	125
2-15R	1.5 <sup>b</sup>	60	250
		66	208
2-20R	2 <sup>b</sup>	72	250
		79.2	208
2-30R	2 <sup>b</sup>	72	250
		79.2	208
5-15R	0.5	58.8	125
5-20R	1	96	125
5-30R	2	144	125
5-50R	2	144	125
6-15R	1.5 <sup>b</sup>	60	250
		66	208
6-20R	2 <sup>b</sup>	72	250

UL COPYRIGHTED MATERIAL –  
NOT AUTHORIZED FOR FURTHER REPRODUCTION OR  
DISTRIBUTION WITHOUT PERMISSION FROM UL

Table 111.2 Continued on Next Page

Table 111.2 Continued

NEMA configuration	AC HP rating <sup>a</sup>	LRA (amperes)	AC test voltage
6-30R	2 <sup>b</sup>	79.2	208
		72	250
6-50R	3 <sup>b</sup>	79.2	208
		102	250
		112.2	208
7-15R	2	59.8	277
7-20R	2	59.8	277
7-30R	3	84.7	277
7-50R	5	139.4	277
10-20R	2 L-L <sup>b</sup>	72	250
		79.2	208
	1 L-N	96	125
10-30R	2 L-L <sup>b</sup>	72	250
		79.2	208
	2 L-N	144	125
10-50R	3 L-L <sup>b</sup>	102	250
		112.2	208
	2 L-N	144	125
11-15R	2	50	250
11-20R	3	64	250
11-30R	3	64	250
11-50R	7.5	132	250
14-15R	1.5 L-L <sup>b</sup>	60	250
		66	208
	0.5 L-N	58.8	12
14-20R	2 L-L <sup>b</sup>	72	250
		79.2	208
	1 L-N	96	125
14-30R	2 L-L <sup>b</sup>	72	250
		79.2	208
	2 L-N	144	125
14-50R	3 L-L <sup>b</sup>	102	250
		112.2	208
	2 L-N	144	125
14-60R	3 L-L <sup>b</sup>	102	250
		112.2	208
	2 L-N	144	125

UL COPYRIGHTED MATERIAL –  
NOT AUTHORIZED FOR FURTHER REPRODUCTION OR  
DISTRIBUTION WITHOUT PERMISSION FROM UL

Table 111.2 Continued on Next Page

Table 111.2 Continued

NEMA configuration	AC HP rating <sup>a</sup>	LRA (amperes)	AC test voltage
15-15R	2	50	250
15-20R	3	64	250
15-30R	3	64	250
15-50R	7.5	132	250
15-60R	10	168	250
18-15R	2	55	208
18-20R	2	55	208
18-30R	3	71	208
18-50R	7.5	145.2	208
18-60R	7.5	145.2	208
L1-15R	0.5	58.8	125
L2-20R	2 <sup>b</sup>	72	250
		79.2	208
L5-15R	0.5	58.8	125
L5-20R	1	96	125
L5-30R	2	144	125
L6-15R	1.5 <sup>b</sup>	72	250
		79.2	208
L6-20R	2 <sup>b</sup>	72	250
		79.2	208
L6-30R	2 <sup>b</sup>	72	250
		79.2	208
L7-15R	2	59.8	277
L7-20R	2	59.8	277
L7-30R	3	84.7	277
L8-20R	3	51	480
L8-30R	5	84	480
L10-20R	2 L-L <sup>b</sup>	72	250
		79.2	208
	1 L-N	96	125
L10-30R	2 L-L <sup>b</sup>	72	250
		79.2	208
	2 L-N	144	125
L11-15R	2	50	250
L11-20R	3	64	250
L11-30R	3	64	250
L12-20R	5	45.6	480
L12-30R	10	84	480

UL COPYRIGHTED MATERIAL –  
NOT AUTHORIZED FOR FURTHER REPRODUCTION OR  
DISTRIBUTION WITHOUT PERMISSION FROM UL

Table 111.2 Continued on Next Page



Table 111.2 Continued

NEMA configuration	AC HP rating <sup>a</sup>	LRA (amperes)	AC test voltage
L14-20R	2 L-L <sup>b</sup>	72	250
		79.2	208
L14-30R	2 L-L <sup>b</sup>	96	125
		72	250
		79.2	208
	2 L-N	144	125
L15-20R	3	64	250
L15-30R	3	64	250
L16-20R	5	45.6	480
L16-30R	10	84	480
L18-20R	2	55	208
L18-30R	3	71	208
L19-20R	5	45.6	480
L19-30R	10	84	480
L21-20R	2	55	208
L21-30R	3	71	208
L22-20R	5	45.6	480
L22-30R	10	84	480

<sup>a</sup> The phase to phase horsepower ratings are noted by "L-L". The phase to neutral ratings are identified by "L-N".

<sup>b</sup> Also suitable for 208 V motor applications at the indicated horsepower rating.

## 112 Temperature Test

### 112.1 Contact and terminal temperature

112.1.1 The temperature rise of a receptacle measured as at the points described in 112.1.2, shall not be more than 30°C (54°F) when the device is carrying its maximum rated current.

112.1.2 Each of six devices is to be tested. Temperatures are to be measured by means of thermocouples attached to the wiring terminals of the device when they are accessible for the mounting of thermocouples.

*Exception: When the wiring terminals are not accessible for mounting thermocouples or when the device is not provided with wiring terminals, the thermocouples are to be attached to the blades of the mated attachment plug as close as possible to the face of the device.*

**UL COPYRIGHTED MATERIAL –  
NOT AUTHORIZED FOR FURTHER REPRODUCTION OR  
DISTRIBUTION WITHOUT PERMISSION FROM UL**

112.1.3 The temperature test is to be made following the overload test on the devices and is to continue until stabilized temperatures are attained. A temperature is considered to be stabilized when three consecutive readings, taken at 5-minute intervals, indicate no further rise above the ambient temperature.

112.1.4 The generation of heat from sources other than the female contacts is to be minimized as much as possible. Each connection to the device being tested is to be made by means of a 12-inch (300-mm) or greater length of Type RH, Type TW, or other equivalent building wire. The wire size and type are to be determined using the appropriate value for the device's current rating from Table 310-16 of the National Electrical Code, ANSI/NFPA 70, as follows:

- a) Ampacities for copper conductors temperature rated at 60°C (140°F) for a receptacle rated 100 A or less for use on copper conductors only.
- b) Ampacities for copper conductors temperature rated at 75°C (167°F) for a receptacle rated greater than 100 A for use on copper conductors only.
- c) Ampacities for copper conductors temperature rated at 60°C (140°F) for an AL-CU receptacle.
- d) Ampacities for copper conductors temperature rated at 60°C (140°F) for a CO/ALR receptacle.

*Exception: An AL-CU receptacle identified for use on 75°C (167°F) wire is to be wired with the conductors specified in Table 112.1.*

**Table 112.1**  
**Test conductor sizes for AL-CU receptacles identified for use on 75°C (167°F) wire**

Device rating, A	Test conductor type and size, AWG (mm <sup>2</sup> )
30	aluminum, 10 (5.3)
50	copper, 8 (8.4)
60	copper, 6 (13.3)

112.1.5 The contacts of the device being tested are to be connected together by means of a mated attachment plug. For devices with a 1-15R, 5-15R, 5-20R, 6-15R or 6-20R configuration, the mating plugs shall have the configurations specified in Table 112.2. The plug is to have rigidly attached solid blades and the terminals of the plug are to be short-circuited by means of the shortest feasible length of flexible cord that has an ampacity at least equal to that of the device. The wire size and type are to be determined using the appropriate value for the device's current rating from Table 400.5(A) or 400.5(B) of the National Electrical Code, ANSI/NFPA 70.

112.1.5 revised May 14, 2004

**UL COPYRIGHTED MATERIAL –  
NOT AUTHORIZED FOR FURTHER REPRODUCTION OR  
DISTRIBUTION WITHOUT PERMISSION FROM UL**

**Table 112.2**  
**Mating plug configurations for temperature testing**

Device under test	Mating plug	No. of devices tested
1-15R	1-15P	6
5-15R	5-15P	6
5-20R	5-15P	3
	5-20P	3
6-15R	6-15P	6
6-20R	6-15P	3
	6-20P	3

112.1.6 The terminals are to be tightened to the marked torque limit or, when a tightening torque is not provided, the torque used is to be 9 in-lbf (1.0 N·m) for devices rated 15 A or less and 14 in-lbf (1.6 N·m) for other ratings.

112.1.7 Temperature readings are to be obtained by means of thermocouples consisting of 28 – 32 AWG (0.8 – 0.032 mm<sup>2</sup>) iron and constantan wires with a potentiometer type of indicating instrument. This equipment is to be used when a referee measurement of temperature is necessary.

112.1.7 revised November 16, 2007

## 112.2 Feed-through terminal temperature

112.2.1 The temperature rise of the terminals of a receptacle that has a current rating of 15 or 20 A at 125 or 250 V and that is provided with wiring terminals for through connection, shall not be more than 30°C (54°F) when a current of 20 A is passed through both terminals.

*Exception: A receptacle that employs the conventional form of terminal plate with two wire-binding screws or pressure-wire connectors is not required to be subjected to this test.*

112.2.2 The test is to be made in accordance with 112.1.2 – 112.1.6 but without a load on the receptacle contacts. Approximately 12-inch (300-mm) lengths of 12 AWG (3.3 mm<sup>2</sup>) wire are to be used for connections.

112.2.2 revised November 16, 2007

112.2.3 Temperature readings are to be obtained by means of thermocouples consisting of 28 – 32 AWG (0.8 – 0.032 mm<sup>2</sup>) iron and constantan wires with a potentiometer type of indicating instrument. This equipment is to be used when a referee measurement of temperature is necessary.

112.2.3 revised November 16, 2007

## 113 Retention of Plugs Test (Repeated)

### 113.1 General

113.1.1 After completion of the Overload Test, Section 111, and the Temperature Test, Section 112, the contacts of a 1-15R, 5-15R, 5-20R, 6-15R or 6-20R configuration receptacle, other than the flush or self-contained type, shall retain an attachment plug so that when tested as described in this section:

- a) A force greater than 3 lbf (13 N) is required to withdraw the plug, and
- b) A force of 15 lbf (67 N) is capable of withdrawing the plug.

*Exception: A receptacle that has provision for locking the plug in place after the blades have been inserted in the female contacts (such as a rotating collar) is not required to be subjected to this test.*

### 113.2 Plug retention

113.2.1 1 Each of six devices is to be tested. A standard solid-blade attachment plug that has American National Standard detent holes, in accordance with Wiring Devices – Dimensional Specifications, ANSI/NEMA WD6, in rigidly mounted blades is to be fully inserted into the device. The test plugs are to have the configuration specified in Table 113.1. A pull of 3 lbf (13 N) in a direction perpendicular to the plane of the face of the receptacle and tending to withdraw the plug from the device is then to be applied to the plug for 1 minute. The displacement of the plug shall not be greater than 0.079 inch (2 mm).

**Table 113.1**  
**Mating plug configurations for plug retention**

Device under test	Mating plug	No. of devices tested
1-15R	1-15P	6
5-15R	1-15P	6
5-20R	1-15P	3
	5-20P <sup>a</sup>	3
6-15R	2-15P	6
6-20R	2-15P	3
	6-20P <sup>a</sup>	3

<sup>a</sup> Shall have the ground blade removed.

### 113.3 Plug withdrawal

113.3.1 Each of six devices is to be tested. Following the application of the 3 lbf (13 N), the pull is to be increased to 15 lbf (67 N), using test plugs having the configuration specified in Table 113.2, and the plug shall be withdrawn by the force.

**Table 113.2**  
**Mating plug configurations for plug withdrawal**

Device under test	Mating plug <sup>a</sup>	No. of devices tested
1-15R	1-15P	6
5-15R	5-15P	6
5-20R	5-15P	3
	5-20P	3
6-15R	6-15P	6
6-20R	6-15P	3
	6-20P	3

<sup>a</sup> Shall have American National Standard detent holes in accordance with Wiring Devices – Dimensional Specifications, ANSI/NEMA WD6.

### 114 Resistance to Arcing Test

114.1 If a material is used in the construction of the face of a receptacle in a way that the material is likely to be exposed to arcing while in service, the devices that were subjected to 50 cycles of operation in the overload test described in Overload Test, Section 111, shall perform acceptably when subjected to an additional 200 cycles of operation under the overload-test conditions following the temperature test and the repetition (if required – see 110.2) of the retention-of-plugs and gripping tests. There shall not be any indication of electrical tracking, formation of a permanent carbon conductive path or ignition of the material. The attachment plugs used for this test may be changed after every 50 operations.

114.1 revised October 23, 2002

114.2 Alternatively one set of devices may be subjected to the 50 cycles of operation in the overload test described in Overload Test, Section 111, followed by the temperature test on the devices and then, to determine resistance to arcing, a second, previously untested set of devices may be subjected to 250 cycles of operation under the overload-test conditions.

**UL COPYRIGHTED MATERIAL –  
NOT AUTHORIZED FOR FURTHER REPRODUCTION OR  
DISTRIBUTION WITHOUT PERMISSION FROM UL**

## 115 Fuseholder Temperature Test

115.1 When tested as described in this section, the temperature rise of a receptacle incorporating a fuseholder shall not exceed the following:

- a) 30°C (54°F) on the fuse clips when tested with a dummy fuse;
- b) 85°C (153°F) on the fuse clips when tested with a live fuse;
- c) 30°C (54°F) at the wiring terminals or cord connections at any time (see 115.7); and
- d) The relative thermal index of the surrounding insulating material, minus an assumed ambient of 25°C (77°F), at any time (see 115.7).

115.2 The test is to be conducted on a set of six previously untested devices. The test may be conducted with either a live fuse or a dummy fuse (see 115.6 and 115.7).

*Exception: The test may be conducted in conjunction with the Temperature Test, Section 107, if agreeable to all concerned.*

115.3 The receptacles are to be wired in a series circuit as described in the Temperature Test, Section 107.

115.4 Temperatures are to be measured by means of thermocouples attached to the fuse clips, the insulating material of the device body in proximity to the fuseholder, and the wiring terminals or cord connections.

*Exception: If the wiring terminals or cord connections are not accessible for mounting thermocouples, the thermocouples are to be attached to the blades as close as possible to the face of the device.*

115.5 The test is to continue until stabilized temperatures are attained. A temperature is considered to be stabilized when three consecutive readings, taken at 5-minute intervals, indicate no further rise above the ambient temperature.

115.6 If the test is to be conducted with a live fuse, the devices are to be tested with the largest ampere-rated fuse intended for use with the device installed and subjected to a test current equal to the maximum fuse ampere rating.

115.7 If the test is to be conducted with a dummy fuse, the devices are to be subjected to a test current equal to the maximum ampere rating of the intended fuse. The dummy fuse size for devices incorporating Class CC, G, H, J, K, or R is to be as specified in the Standard for Fuseholders – Part 1: General Requirements, UL 4248-1, the Standard for Fuseholders – Part 4: Class CC, UL 4248-4, the Standard for Fuseholders – Part 5: Class G, UL 4248-5, the Standard for Fuseholders – Part 6: Class H, UL 4248-6, the Standard for Fuseholders – Part 8: Class J, UL 4248-8, the Standard for Fuseholders – Part 9: Class K, UL 4248-9, the Standard for Fuseholders – Part 11: Type C (Edison Base) and Type S Plug Fuse, UL 4248-11, the Standard for Fuseholders – Part 12: Class R, UL 4248-12, and the Standard for Fuseholders – Part 15: Class T, UL 4248-15. The dummy fuse size for devices employing miscellaneous, miniature and micro fuses is to be as indicated in Table 115.1. To represent the heating of a live fuse, 20°C (36°F) is to be added to the recorded temperature rise on the wiring terminals, cord connections, and surrounding insulating materials.

115.7 revised November 16, 2007

**UL COPYRIGHTED MATERIAL –  
NOT AUTHORIZED FOR FURTHER REPRODUCTION OR  
DISTRIBUTION WITHOUT PERMISSION FROM UL**

**Table 115.1**  
**Nominal dimensions of dummy fuses for miscellaneous, miniature and micro fuses**

Size of fuse	Dimensions		
	Outside diameter	Wall thickness	Length
5 x 20 mm (0.2 x 0.8 inches)	5 mm (0.2 inches)	1.2 mm (0.047 inches)	20 mm (0.8 inches)
1/4 x 1-1/4 inches (6.4 x 31.8 mm)	0.25 inches (6.4 mm)	0.049 inches (1.2 mm)	1-1/4 inches (31.8 mm)

115.8 The thermocouples are to consist of 28 – 32 AWG (0.08 – 0.032 mm<sup>2</sup>) iron and constantan wires. It is a common practice to employ thermocouples consisting of 30 AWG (0.05 mm<sup>2</sup>) iron and constantan wires with a potentiometer type of indicating instrument. This equipment will be used if a referee measurement of temperature is necessary.

115.8 revised November 16, 2007

## 116 Fault Current Test

116.1 When a flush or self-contained receptacle having a 5-15R, 5-20R, 6-15R, or 6-20R configuration is tested as described in this section, the circuit breaker shall operate when the test circuit is closed. The grounding path shall retain its integrity as demonstrated by a continuity check after removing and reinserting the attachment plug.

116.2 Each receptacle is to be tested at rated voltage on a circuit capable of delivering 1000 A rms at 125 V to ground through shorted bus bars. The line and ground terminals of each receptacle are to be wired to the supply terminals using a total of 4 ft (1.22 m) of 12 AWG (3.3 mm<sup>2</sup>) wire with the receptacle installed in a flush device box with a metal faceplate. A 20 A circuit breaker for branch circuit protection is to be connected between the receptacle line terminal and one supply terminal. The circuit is to be completed by the insertion into the energized receptacle of a standard solid blade grounding-type attachment plug with a 2-ft (0.61-m) length of flexible cord having 14 AWG (2.1 mm<sup>2</sup>) conductors with the bared ends of the ungrounded and grounding conductors twisted together, soldered, and insulated. Each receptacle is to be tested once. Duplex receptacles are to be tested using one set of contacts for half of the test and the other set of contacts for the remainder of the test.

*Exception: When testing a receptacle intended to be used only on a 15-A branch circuit and so marked, it is to be wired to the test terminals using a total of 4 ft (1.22 m<sup>2</sup>) of 14 AWG (2.1 mm<sup>2</sup>) solid copper wire and a 15-A circuit breaker is to be employed.*

116.2 revised November 16, 2007

## 117 Terminal Strength Test

117.1 A flush or self-contained receptacle having a 5-15R, 5-20R, 6-15R, or 6-20R configuration, when tested as described in this section, shall not exhibit:

- a) Damage to the receptacle including but not limited to breakage of the housing, misalignment of contacts, or stripping of the terminal plates or screws;
- b) Visible displacement of the wires relative to the terminals following the pull test described in 117.7;
- c) Interference with the insertion of a mating attachment plug or its seating against the receptacle face;
- d) Forces in excess of 40 lbf (178 N) required to seat a standard gauge against the receptacle face during the conditioning described in 117.3 or during the plug retention and withdrawal evaluations described in 117.8 and 117.9;
- e) Displacement of the standard gauge of more than 0.079 inches (2 mm) during the plug retention evaluation described in 117.8; or
- f) Inability to release the standard gauge during the plug release evaluation described in 117.9.

117.2 Previously untested receptacles are to be used for this test as follows:

- a) Three receptacles if the device employs wire-binding screws alone or in combination with push-in terminals;
- b) Three receptacles if the device employs pressure-wire terminals only; or
- c) Six receptacles if the device employs wire-binding screws in combination with pressure-wire terminals.

117.3 The contacts of the receptacle are to be subjected to ten conditioning cycles of manual insertion and withdrawal of the standard gauge shown in Figure 105.1. In the case of a duplex receptacle, both sets of contacts are to be conditioned. The gauge is to be assembled with the grounding pin and with the line blades without the holes in the outer ends of the blades. A receptacle rated 20 A with the "T" slot contact is to be subjected to the conditioning cycles with the gauge assembled in the 15 A configuration. If the receptacle is provided with breakoff tabs, one tab is to be removed from one line terminal on each device prior to the conditioning. The receptacle shall comply with 117.1 (a), (c), and (d) upon completion of this conditioning.

117.4 After the receptacle contacts have been conditioned, one line terminal and one neutral terminal on each outlet of a receptacle rated 125 V, or one line terminal on each pole on each outlet of a 250 V receptacle, are to be wired as outlined in Table 117.1 for single receptacles or in Table 117.2 for duplex receptacles.



117.5 Each terminal is to be wired with 12 AWG (3.3 mm<sup>2</sup>) solid copper conductor by applying the tightening torque as specified in Table 117.3 to the terminal screw. The wire is to be stripped to the length specified in the manufacturer's installation instructions. Wire-binding screw terminals are to be wired by placing the stripped conductor under the screw head and wrapping it 2/3 – 3/4 turn around the screw. Pressure-wire terminals are to be wired by placing the stripped conductor into the terminal. The conductor is to be seated to follow any wire guides or other openings provided to align the conductor with the back of the receptacle housing. The terminal screw is to be tightened with a clutch-type torque screwdriver which has been calibrated and preset to release at the specified value. The receptacle shall comply with 117.1 (a) upon completion of this procedure.

117.5 revised November 16, 2007

**Table 117.1**  
**Terminal testing configurations single receptacles**

Terminal type	No. of devices	Terminals to be wired on each device (see 117.4)
Wire-binding screw (alone or in combination with push-in terminals)	3	Two wire-binding screw terminals
Pressure-wire terminal only, 1 wire entry per terminal	3	Two pressure-wire terminals
Pressure-wire terminal only, 2 wire entries per terminal	1	Two pressure-wire terminals wired using Configuration No. 1 <sup>a</sup>
	1	Two pressure-wire terminals wired using Configuration No. 2 <sup>a</sup>
	1	Two pressure-wire terminals wired using Configuration No. 3 <sup>a</sup>
Combination wire-binding screw and pressure-wire terminal, 1 wire entry per terminal	3	Two wire-binding screw terminals
	3	Two pressure-wire terminals
Combination wire-binding screw and pressure-wire terminal, 2 wire entries per terminal	3	Two wire-binding screw terminals
	1	Two pressure-wire terminals wired using Configuration No. 1 <sup>a</sup>
	1	Two pressure-wire terminals wired using Configuration No. 2 <sup>a</sup>
	1	Two pressure-wire terminals wired using Configuration No. 3 <sup>a</sup>

<sup>a</sup> The wiring configurations for pressure-wire terminals with two wire entries per terminal are shown in Figure 117.1.

**UL COPYRIGHTED MATERIAL –  
NOT AUTHORIZED FOR FURTHER REPRODUCTION OR  
DISTRIBUTION WITHOUT PERMISSION FROM UL**

**Table 117.2**  
**Terminal testing configurations duplex receptacles**

Terminal type	No. of devices	Outlet tested	Terminals to be wired on each device (see 117.4)
Wire-binding screw (alone or in combination with push-in terminals)	3	Both	Two wire-binding screw terminals
Pressure-wire terminal only, 1 wire entry per terminal	3	Both	Two pressure-wire terminals
Pressure-wire terminal only, 2 wire entries per terminals	1	Both	Two pressure-wire terminals wired using Configuration No. 1 <sup>a</sup>
	1	Both	Two pressure-wire terminals wired using Configuration No. 2 <sup>a</sup>
	1	Both	Two pressure-wire terminals wired using Configuration No. 3 <sup>a</sup>
Combination wire-binding screw and pressure-wire terminal, 1 wire entry per terminal	3	Upper	Two wire-binding screw terminals
	3	Lower	Two pressure-wire terminals
		Upper	Two pressure-wire terminals
Combination wire-binding screw and pressure-wire terminal, 2 wire entries per terminal	1	Lower	Two wire-binding screw terminals
		Upper	Two pressure-wire terminals wired using Configuration No. 1 <sup>a</sup>
		Lower	Two pressure-wire terminals wired using Configuration No. 2 <sup>a</sup>
	1	Upper	Two wire-binding screw terminals
		Lower	Two pressure-wire terminals wired using Configuration No. 3 <sup>a</sup>
	1	Upper	Two pressure-wire terminals wired using Configuration No. 1 <sup>a</sup>
		Lower	Two wire-binding screw terminals
	1	Upper	Two pressure-wire terminals wired using Configuration No. 2 <sup>a</sup>
		Lower	Two wire-binding screw terminals

**UL COPYRIGHTED MATERIAL –  
NOT AUTHORIZED FOR FURTHER REPRODUCTION OR  
DISTRIBUTION WITHOUT PERMISSION FROM UL**

Table 117.2 Continued on Next Page

Table 117.2 Continued

Terminal type	No. of devices	Outlet tested	Terminals to be wired on each device (see 117.4)
	1	Upper	Two pressure-wire terminals wired using Configuration No. 3 <sup>a</sup>
		Lower	Two wire-binding screw terminals

<sup>a</sup> The wiring configurations for pressure-wire terminals with two wire entries per terminal are show in Figure 117.1.

Table 117.3  
Terminal screw tightening torque

Screw size	Tightening torque pound-inches (N-m)
No. 6 or less	12 (1.4)
No. 8 or greater	14 (1.6)

Figure 117.1  
Wiring configurations for back-wired terminals

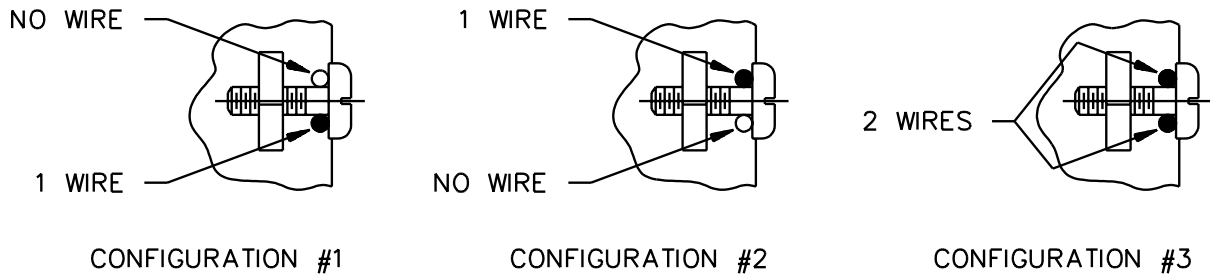

S3636

117.6 Each termination is then to be disassembled and the assembly and torquing repeated once using newly stripped wire. The receptacle shall comply with 117.1 (a) upon completion of this procedure.

**UL COPYRIGHTED MATERIAL –  
NOT AUTHORIZED FOR FURTHER REPRODUCTION OR  
DISTRIBUTION WITHOUT PERMISSION FROM UL**

117.7 Following the last torquing, each terminal is to be subjected to a straight 20-lbf (89-N) pull applied to each wire for 1 minute perpendicular to the plane of the back cover of the receptacle. The receptacle shall comply with 117.1 (a) and (b) upon completion of this procedure.

117.8 The standard gauge shown in Figure 105.1 assembled without the grounding pin and with the line blades without holes in the outer ends of the blades is then to be inserted into each outlet of the receptacle while measuring the insertion force. A receptacle rated 20 A with the "T" slot contact is to be tested with the gauge assembled in the 15 A configuration. A static 3 lbf (13.3 N) is then to be applied for a period of one minute in a direction perpendicular to the plane of the face of the receptacle that tends to remove the gauge from the outlet. The receptacle shall comply with 117.1 (a), (c), (d), and (e) upon completion of this procedure.

117.9 The standard gauge is then to be reconfigured with the grounding pin and with line blades with holes in the outer ends of the blades and inserted into each outlet of the receptacle. A receptacle rated 20 A with the "T" slot contact is to be tested with the gauge assembled in the 15 A configuration. A static 15 lbf (67 N) is to be applied to the gauge in a direction perpendicular to the plane of the face of the receptacle that tends to remove the gauge from the outlet. The receptacle shall comply with 117.1 (a), (c), (d), and (f) upon completion of this procedure.

### 118 Assembly Security Test

118.1 A flush receptacle having a 5-15R, 5-20R, 6-15R, or 6-20R configuration is to be mounted in the fixture described in Figure 118.1, and 50 lbf (220 N) is to be applied, as shown in Figure 118.2, for a period of 10 s by means of a push-out tool inserted into the slots of the receptacle. The push-out tool required for configuration 5-15R is to be as shown in Figure 118.3. The tool used for configurations 5-20R, 6-15R, and 6-20R is to have the same design but is to be modified to fit the slots. For a single receptacle, the push-out tool (see Figure 118.3) is to be modified to have a single set of blades.

*Exception: A self-contained receptacle having a 5-15R, 5-20R, 6-15R, or 6-20R configuration shall instead be subjected to the Assembly Security Test, Section 144.*

**Figure 118.1**  
**Receptacle test fixture**

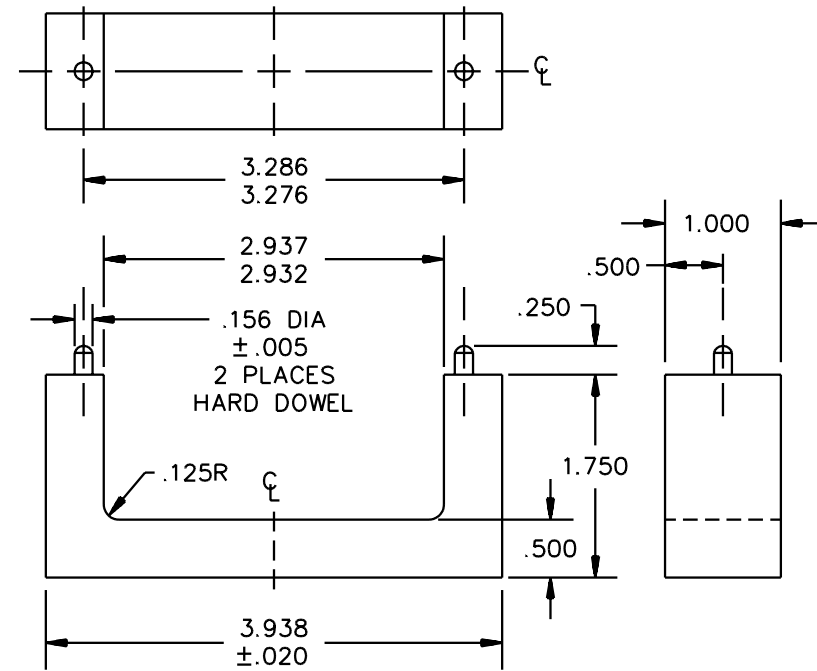

SB1276A

Inches	mm
0.005	0.13
0.020	0.51
0.125	3.18
0.156	3.96
0.250	6.35
0.500	12.70
1.000	25.40
1.750	44.45
2.932	74.47
2.937	74.60
3.276	83.21
3.286	83.46
3.938	100.03

NOTES

- 1) Dimensions are in inches.
- 2) Metric equivalents are given in general information only and are based upon 1.00 inch = 25.4 mm.
- 3) Unless otherwise specified, tolerance is  $\pm 0.010$  inch (0.25 mm).
- 4) The fixture shall be of cold rolled steel.

**UL COPYRIGHTED MATERIAL –  
NOT AUTHORIZED FOR FURTHER REPRODUCTION OR  
DISTRIBUTION WITHOUT PERMISSION FROM UL**

Figure 118.2  
Assembly security test method

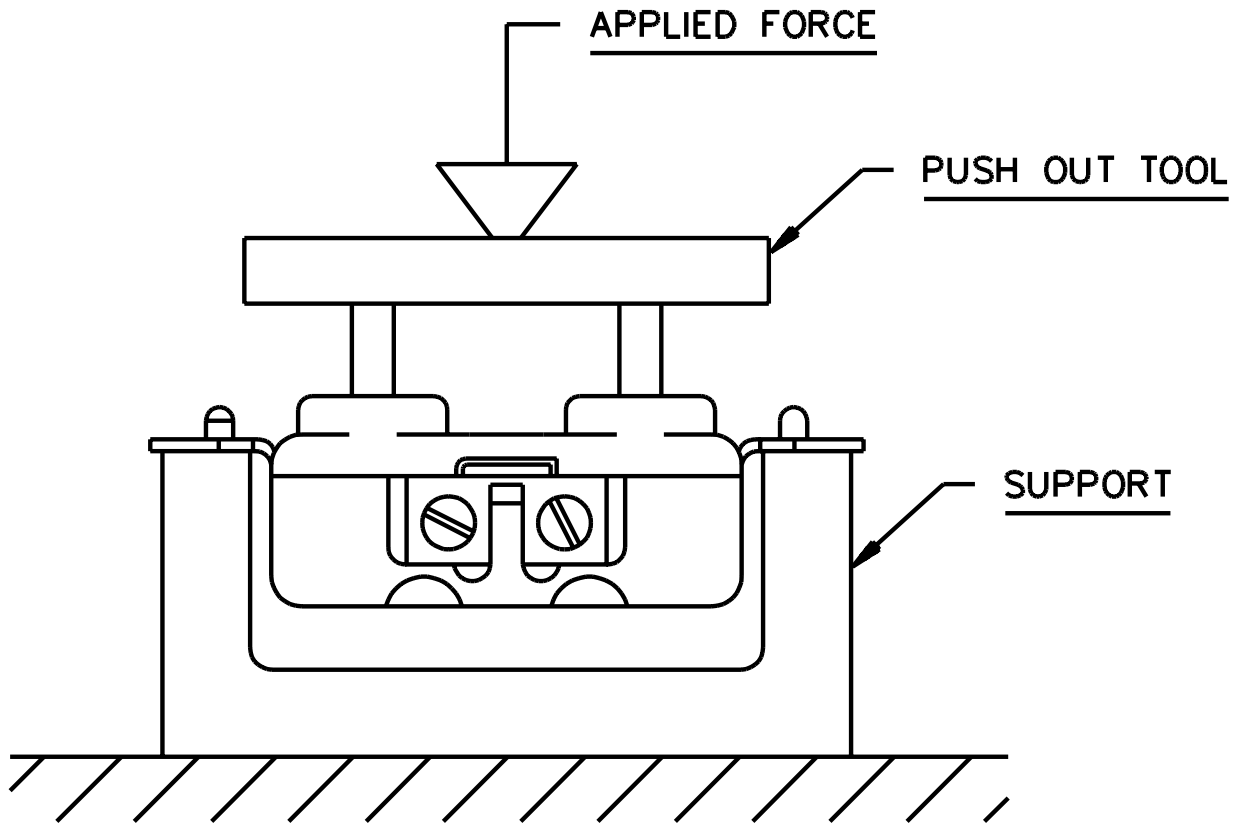

S3637

UL COPYRIGHTED MATERIAL –  
NOT AUTHORIZED FOR FURTHER REPRODUCTION OR  
DISTRIBUTION WITHOUT PERMISSION FROM UL

118.2 There shall not be any mechanical breakage of the receptacle that exposes live parts or separation of the face and body by more than 1/16 inch (1.6 mm), measured after removal of the applied force. There shall not be any permanent deformation of the yoke that would render the receptacle incapable of functioning as intended.

118.3 The receptacle is then to be placed in an inverted position in the test fixture and the 50 lbf (220 N) applied, as shown in Figure 118.4, for a period of 10 s by means of a bridge as shown in Figure 118.5. The criteria of 118.2 shall apply.

118.4 The receptacle shall maintain grounding continuity between the grounding terminal and ground pin. An indicating device such as an ohmmeter, a battery-and-buzzer combination, or similar device is to be used to determine compliance. Additionally it shall be capable of retaining without displacement in excess of 0.079 inch (2 mm) for 1 minute after insertion, the fully inserted test pin illustrated in Figure 119.3. For this test, each receptacle is to be placed with its face horizontal so that the downward force exerted by the pin is perpendicular to the plane of the receptacle face and tends to withdraw the pin.

**Figure 118.3**  
**Pushout tool**

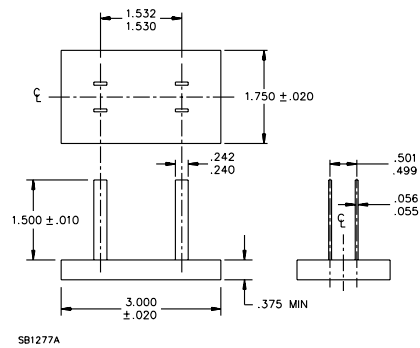

Inches	mm
0.010	0.25
0.020	0.51
0.055	1.40
0.056	1.42
0.240	6.10
0.242	6.15
0.375	9.52
0.499	12.67
0.501	12.73
1.500	38.10
1.530	38.86
1.532	38.91
1.750	44.45
3.000	76.30

**NOTES**

- 1) Dimensions are in inches.
- 2) Metric equivalents are given for general information only and are based upon 1.00 inch = 25.4 mm.
- 3) Blades to be parallel to each other and perpendicular to the base within 0.006 inch (0.15 mm) T.I.R.
- 4) Blades are to be fastened to the base in a rigid manner.
- 5) Sharp edges shall be removed to a maximum radius of 0.015 inch (0.38 mm).
- 6) The blade shall be of steel having a Rockwell Hardness of C58 to C60. The handle shall be of cold rolled steel.
- 7) The fixture shall be of cold rolled steel.
- 8) The 1.532/1.530 inch blade location and orientation is capable of being varied to accommodate the construction of the device under test.
- 9) The 3 inch dimension of the tool size represents a nominal value and is capable of being varied to suit the device under test.

**UL COPYRIGHTED MATERIAL –  
NOT AUTHORIZED FOR FURTHER REPRODUCTION OR  
DISTRIBUTION WITHOUT PERMISSION FROM UL**



Figure 118.4  
Assembly security test method (inverted)

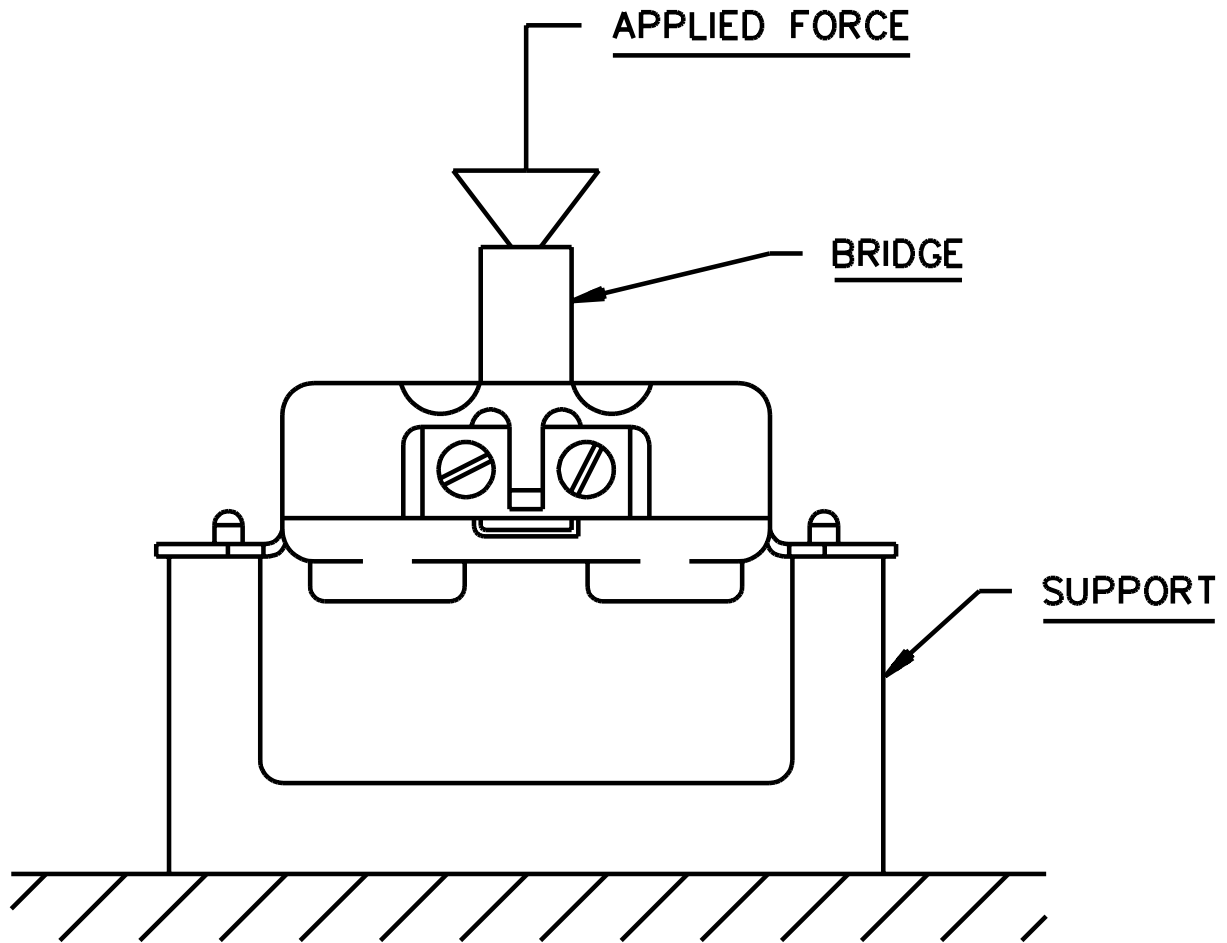

S3637A

UL COPYRIGHTED MATERIAL –  
NOT AUTHORIZED FOR FURTHER REPRODUCTION OR  
DISTRIBUTION WITHOUT PERMISSION FROM UL

Figure 118.5  
Bridge

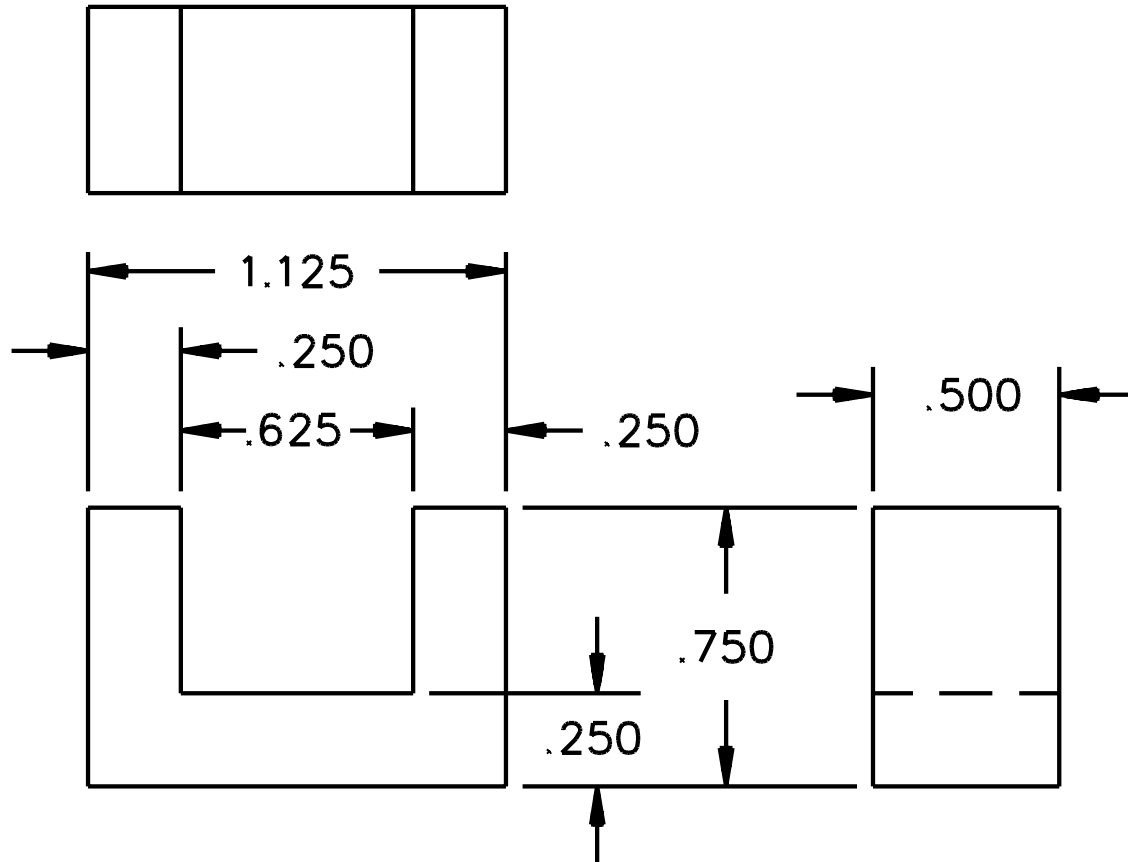

S3638

Inches	mm
0.250	5.35
0.500	12.70
0.625	15.88
0.750	19.05
1.125	28.58

NOTES

- 1) Dimensions are in inches.
- 2) Metric equivalents are given for general information only and are based upon 1.00 inch = 25.4 mm.
- 3) Unless otherwise specified, tolerance is  $\pm 0.005$  inch (0.13 mm).
- 4) The 0.625 inch (15.88 mm) is capable of being varied so that the tool clears the strap of the receptacle.
- 5) The shape of the bridge is capable of being varied to suit the back of the device being tested.

**UL COPYRIGHTED MATERIAL –  
NOT AUTHORIZED FOR FURTHER REPRODUCTION OR  
DISTRIBUTION WITHOUT PERMISSION FROM UL**

## 119 Grounding Contact Test

119.1 Grounding receptacles having a 5-15R, 5-20R, 6-15R, 6-20R, 7-15R, 14-15R or 15-15R configuration are to be subjected to the tests in this section.

119.2 Previously untested devices are to be used. Each device is to be mounted in a flush device box, or as otherwise intended, with its face in a vertical plane. A nonmetallic faceplate is to be installed if intended. A solid 14 AWG (2.1 mm<sup>2</sup>) copper conductor is to be connected to the receptacle grounding terminal.

119.2 revised November 16, 2007

119.3 With the receptacle oriented to create the maximum contact displacement (possible distortion of contact affecting its contact ability), the test pin A, Figure 119.1 is to be fully inserted in the grounding contact. A 5 lb (1.27 kg) weight is to be gradually suspended from the test pin 6 inches (152 mm) from the face of the receptacle. The weight is to be applied for 1 minute, following which, the weight is to be removed. The application of the weight is to be repeated with the receptacles rotated 90, 180 and 270 degrees for a total of four applications. Usually the test is started with the grounding pin opening directly above, below or on either side of the line slots.

Figure 119.1  
Test pin A

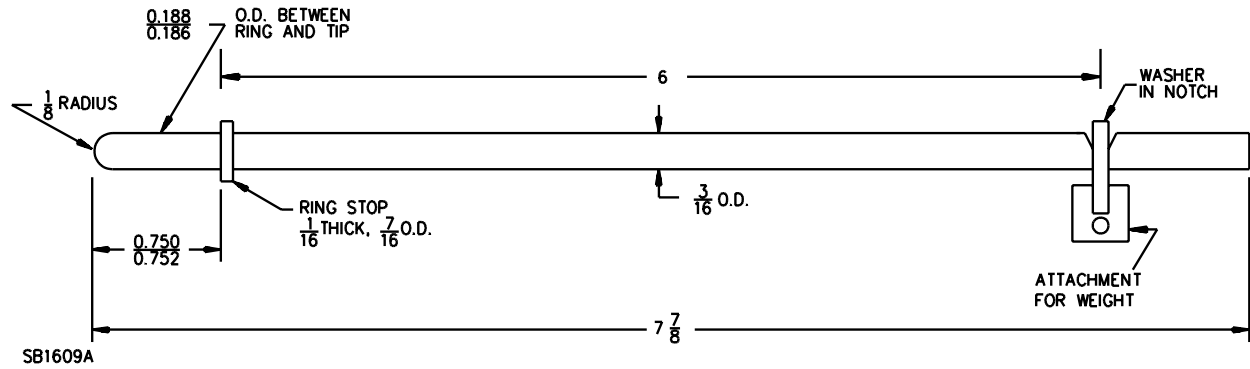

Pin material- tool steel, Rockwell Hardness C58 to C60

inch	1/16	1/8	3/16	0.186	0.188	7/16	0.750	0.752	6	7-7/8
mm	1.6	3.2	4.8	4.72	4.77	11.1	19.05	19.10	152	200

UL COPYRIGHTED MATERIAL -  
NOT AUTHORIZED FOR FURTHER REPRODUCTION OR  
DISTRIBUTION WITHOUT PERMISSION FROM UL

119.4 As a result of the test described in 119.3, there shall not be any breakage of the outlet face of the receptacle that would expose live parts to contact by 1/16 inch (1.6 mm) diameter rod. In addition, there shall not be any breakage or distortion of the insulating body of the receptacle that results in reduction of electrical spacings to values less than those required for the receptacle. The conditioning pin shall remain in place without extraneous support for the required 1 minute in each position.

*Exception: If breakage occurs at the base of the grounding contact opening in a controlled manner so that the breakage is clean and does not expose live parts or break internal barriers, minimal extraneous support of the conditioning pin is not prohibited to complete the stress conditioning on the grounding contacts.*

119.5 Each device is then to be tested for electrical continuity between the receptacle grounding contact and the fully inserted test pin B, Figure 119.2. There shall not be a loss of contact while the pin is moved by hand, without exerting undue pressure, so as to touch all internal walls and surfaces. The stop ring of the pin is to remain continuously in contact with the face of the receptacle. An indicating device, such as an ohmmeter, a battery-and-buzzer combination, or other similar device, is to be used.

119.6 Each device is then to be positioned with the receptacle outlet facing down in a horizontal position. The receptacle shall support the 2 and 4 oz. (57 and 113 g) grounding pin illustrated in Figures 119.3 and 119.4, for 1 minute each when fully inserted in the grounding pin opening.

**UL COPYRIGHTED MATERIAL –  
NOT AUTHORIZED FOR FURTHER REPRODUCTION OR  
DISTRIBUTION WITHOUT PERMISSION FROM UL**

Figure 119.2  
Test pin B

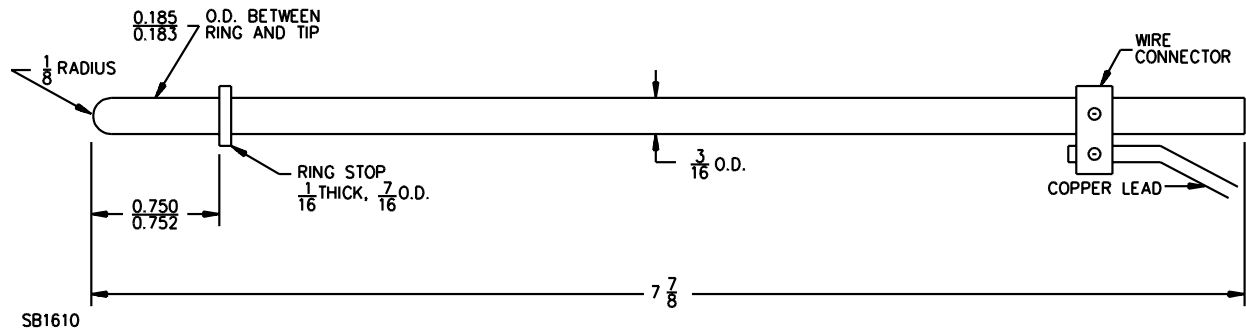

Pin material

inch	1/16	1/8	3/16	0.183	0.185	7/16	0.750	0.752	7-7/8
mm	1.6	3.2	4.8	4.65	4.70	11.1	19.05	19.10	200

UL COPYRIGHTED MATERIAL –  
NOT AUTHORIZED FOR FURTHER REPRODUCTION OR  
DISTRIBUTION WITHOUT PERMISSION FROM UL

**Figure 119.3**  
**2 oz (57 g) ground pin**

Figure 119.3 revised March 15, 2006

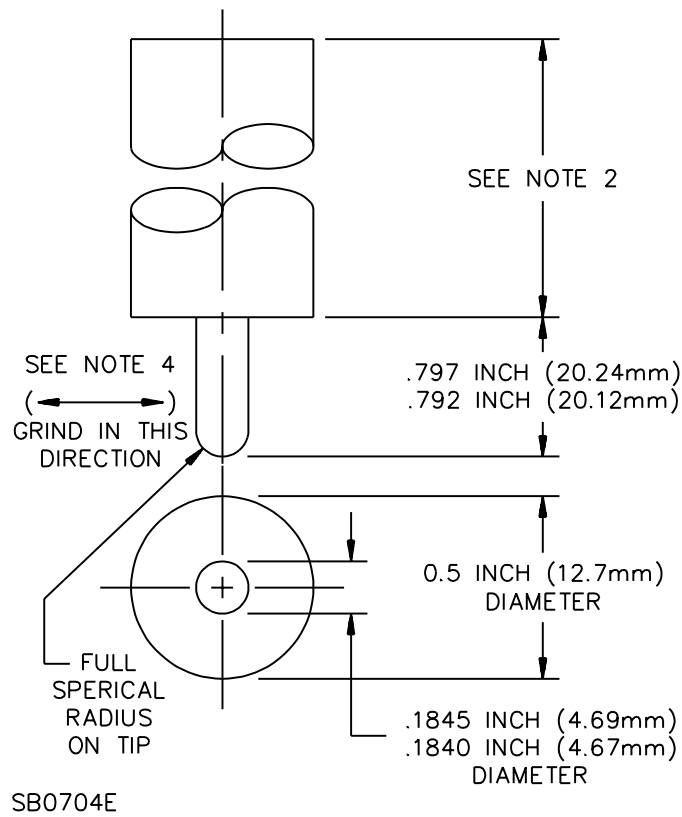

Material: Pin-Steel, Rockwell Hardness C58 to C60.

Handle – cold rolled steel

NOTES

- 1) The ground pin is to be fastened to handle in rigid manner.
- 2) Length not specified. Total tool weight 2 oz (57 g).
- 3) Axis of blade and axis of handle, must have combined concentricity and axial alignment of 0.006 maximum at tip of pin.
- 4) The blade surfaces shall not exceed a 32 microinch finish grind in a direction perpendicular to the major axis. Finish is to be determined visually using a comparative method and 10 X optical magnification.

inch	0.1840	0.1845	0.792	0.797	0.5
(mm)	4.694	4.686	20.12	20.24	12.7
microinch				32	
(nanometer)				813	

**UL COPYRIGHTED MATERIAL –  
NOT AUTHORIZED FOR FURTHER REPRODUCTION OR  
DISTRIBUTION WITHOUT PERMISSION FROM UL**

**Figure 119.4**  
**4 oz (113 g) ground pin**

Figure 119.4 revised March 15, 2006

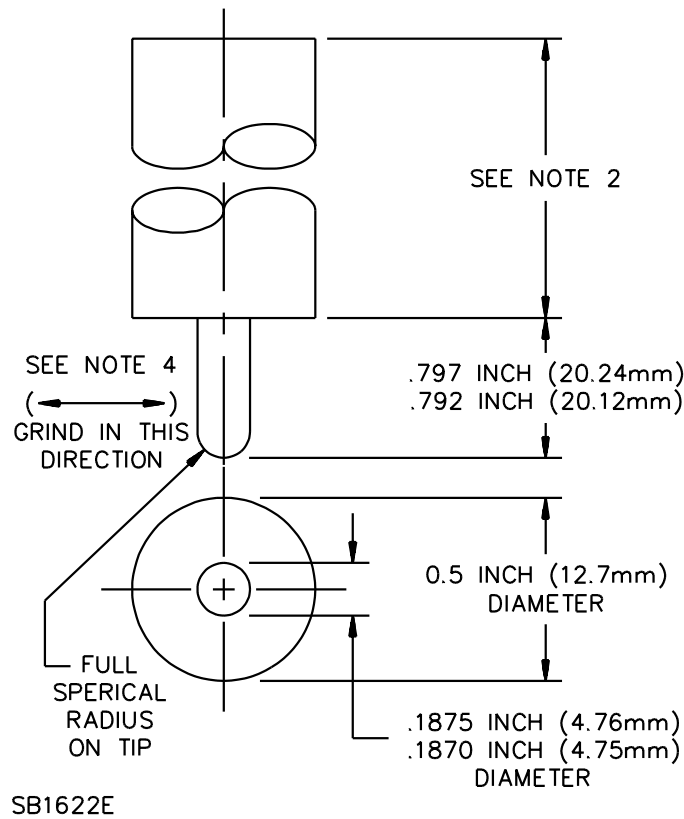

Material: Pin-Steel, Rockwell Hardness C58 to C60.

Handle – cold rolled steel

NOTES

- 1) The ground pin is to be fastened to handle in rigid manner.
- 2) Length not specified. Total tool weight 4 oz (113 g).
- 3) Axis of blade and axis of handle, must have combined concentricity and axial alignment of 0.006 maximum at tip of pin.
- 4) The blade surfaces shall not exceed a 32 microinch finish grind in a direction perpendicular to the major axis. Finish is to be determined visually using a comparative method and 10 X optical magnification.

inch	0.1870	0.1875	0.792	0.797	0.5
(mm)	4.750	4.762	20.12	20.24	12.7
	microinch			32	
	(nanometer)			813	

**UL COPYRIGHTED MATERIAL –  
NOT AUTHORIZED FOR FURTHER REPRODUCTION OR  
DISTRIBUTION WITHOUT PERMISSION FROM UL**



## Pressure-Wire Terminals

**120 General**

120.1 In addition to the requirements in Sections 104 – 119, a receptacle rated 30 A or greater and employing pressure-wire terminals for field connection to both copper and aluminum branch circuit conductors shall comply with the Strength of Insulating Base Test, Section 121, and with the applicable performance requirements in the Standard for Equipment Wiring Terminals for Use with Aluminum and/or Copper Conductors, UL 486E. The test conductors and currents used in the heat cycling tests in UL 486E shall be selected in accordance with Table 120.1. The copper and aluminum test conductors to be used for all other tests in UL 486E shall be selected in accordance with Tables 120.2 and 120.3 respectively.

*Exception: The copper test conductors for an AL-CU range and dryer receptacle intended for use with both copper and aluminum conductors rated 75°C (167°F) shall be selected in accordance with Table 120.4.*

**Table 120.1**  
**Heat cycling test parameters**

Device rating, A	Aluminum test conductor size, AWG	Heat cycling test current, A
30	8	45
50	6	85
60	4	105
100	1	175
200	250 kCmil	350

**Table 120.2**  
**Copper test conductor sizes**

Device Rating, A	Conductor size, AWG
15	14 stranded
	14 solid
	12 stranded
	12 solid
20	12 stranded
	12 solid
30	10 stranded
	10 solid
50	6 stranded
60	4 stranded
100	1 stranded
200	3/0 stranded

**UL COPYRIGHTED MATERIAL –  
NOT AUTHORIZED FOR FURTHER REPRODUCTION OR  
DISTRIBUTION WITHOUT PERMISSION FROM UL**

**Table 120.3**  
**Aluminum test conductor sizes**

Device rating, A	Conductor size, AWG
30	10 stranded 10 solid 8 stranded
50	6 stranded 4 stranded
60	4 stranded 3 stranded
100	1 stranded 1/0 stranded
200	250 kCmil stranded

**Table 120.4**  
**Copper test conductors for AL/CU receptacles identified for use on 75°C (167°F) wire**

Device rating, A	Conductor size, AWG
30	10 stranded 10 solid
50	8 stranded 6 stranded
60	6 stranded 4 stranded

120.2 In addition to the requirements in Sections 104 – 119, the following types of receptacles shall comply with the Strength of Insulating Base Test, Section 121, and with the applicable performance requirements in the Standard for Equipment Wiring Terminals for Use with Aluminum and/or Copper Conductors, UL 486E:

- a) A receptacle rated less than 30 A and employing setscrew-type pressure-wire terminals for field connection to copper branch circuit conductors only.
- b) A receptacle rated 35 A or more and employing setscrew- or clamp-type pressure-wire terminals for field connection to copper branch circuit conductors only.

The copper test conductors to be used in these tests shall be selected in accordance with Table 120.2.

120.3 A receptacle less than 30 A and employing clamp-type pressure-wire terminals intended for use on copper branch circuit conductors only shall comply with the general requirements for receptacles contained in Sections 104 – 119, only.

**UL COPYRIGHTED MATERIAL –  
NOT AUTHORIZED FOR FURTHER REPRODUCTION OR  
DISTRIBUTION WITHOUT PERMISSION FROM UL**

## 121 Strength of Insulating Base Test

121.1 A receptacle employing pressure-wire terminals for field connection to branch circuit conductors shall not be damaged when 110 percent of the specified terminal tightening torque is applied to the wire securing means of the pressure-wire terminal which secures the maximum intended size conductor.

121.2 Damage is considered to have occurred if any cracking, bending, breakage or displacement of the insulating base, current-carrying parts, assembly parts, or device enclosure reduces electrical spacings to less than those required, exposes live parts, or otherwise impairs the intended secure installation and use of the device.

121.3 The terminal tightening torque to be used for this test is to be that assigned by the manufacturer in accordance with 12.4.3 and marked in accordance with Reference No. 17 of Table 163.4.

### Self-Grounding Receptacles

## 122 General

122.1 In addition to the general performance requirements for receptacles, a self-grounding receptacle shall comply with the requirements in Section 123.

## 123 Fault Current Test

123.1 When tested as described in this section, the cotton surrounding the mounting screw and the self-grounding device shall not ignite. Electrical continuity between the mounting yoke and the metal test outlet box shall be maintained. The circuit breaker shall operate as a result of this test.

*Exception: This test is not required for isolated-ground receptacles or receptacles rated more than 150 V to ground that are provided with devices intended solely to bond a metal flush plate to the metal test outlet box. Such devices are not intended for use in lieu of the bonding jumper required by the National Electrical Code, ANSI/NFPA-70.*

123.2 When the receptacle is provided with a self-grounding device on each end of the yoke, each self-grounding device is to be evaluated separately.

123.3 Each of six previously untested receptacles is to be conditioned by completely removing the mounting screw from the self-grounding device and mounting yoke and replacing it three times. The mounting screw is to be removed by exerting a straight pull (not by rotating the screw) using a pair of pliers or other tool and reinserted by exerting a straight push. When mounting screws are not provided, steel flat-headed No. 6-32 mounting screws are to be used.

123.4 Each receptacle is to be tightly installed in a metal test outlet box using the mounting screws provided with the receptacles or steel flat-headed No. 6-32 mounting screws when mounting screws are not provided. Each receptacle is then to be removed from the outlet box and replaced three times without removing the mounting screws from the mounting yoke or self-grounding device. The installations and removals are to be made using a screwdriver or other tool and engaging the screw threads in the mounting hole and self-grounding device in the intended manner.

123.5 Each receptacle is then to be removed from the outlet box. A 4 foot (1.22 m) length of copper wire sized in accordance with Table 123.1 is to be connected to the grounding terminal of the receptacle and a second 4 foot (1.22 m) length is to be connected to the grounding terminal of the outlet box. Each receptacle is then to be installed in the outlet box as shown in Figure 123.1, so that the mounting yoke and all other grounded parts except the mounting screw passing through the self-grounding device are fully isolated from the outlet box. To isolate the box, the mounting screw passing through the self-grounding device is to be tightened to seat the yoke securely against the outlet box, then backed off until the yoke and the outlet box are separated by 1/4 inch (6.4 mm). The mounting screw and self-grounding device are to be loosely covered with cotton. The other end of the yoke is to be secured to the outlet box by a plastic mounting screw.

**Table 123.1**  
**Grounding conductor sizes**

Receptacle rating, A	Grounding conductor size, AWG (mm <sup>2</sup> )
15	14 (2.1)
20	12 (3.3)
30	10 (5.3)

**UL COPYRIGHTED MATERIAL –  
NOT AUTHORIZED FOR FURTHER REPRODUCTION OR  
DISTRIBUTION WITHOUT PERMISSION FROM UL**

**Figure 123.1  
Fault current assembly**

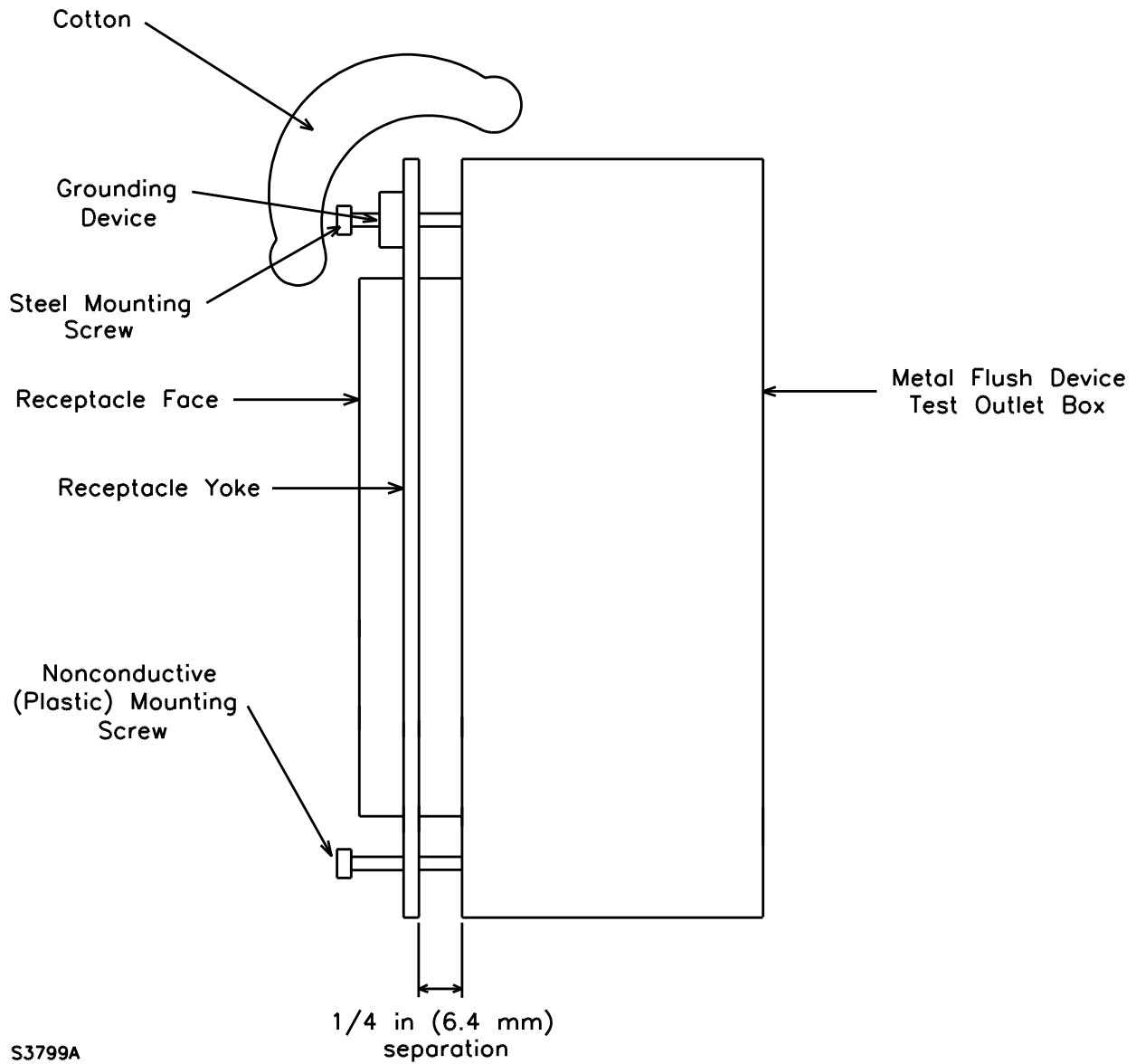

S3799A

NOTES

- 1) The test outlet box dimensions may vary to fit receptacle under test.
- 2) The test outlet box shall be either an outlet box that complies with the Standard for Metallic Outlet Boxes, UL 514A, or a test fixture made of sheet metal other than aluminum, not less than 0.0625 inch (1.59 mm) and shall employ threaded screwholes for No. 6-32 screws with a minimum of 2 full threads in the metal.

**UL COPYRIGHTED MATERIAL –  
NOT AUTHORIZED FOR FURTHER REPRODUCTION OR  
DISTRIBUTION WITHOUT PERMISSION FROM UL**

123.6 The free ends of the conductors are to be connected to a source capable of delivering a test current of 1000 A at the receptacle's rated voltage to ground with a power factor of 75 to 80 percent. A circuit breaker intended for branch circuit protection of the same rating as the receptacle under test but not less than 20 A is to be installed in series with the conductor connected to the outlet box.

123.7 After subjecting each receptacle to one application of the test current, the cotton is to be examined for ignition. Electrical continuity between the self-grounding device and the outlet box is to be checked using an ohmmeter, battery-and-buzzer combination, or other similar indicating device.

#### Push-In Terminals

### 124 General

124.1 In addition to the general requirements for receptacles, receptacles employing push-in terminals shall comply with the requirements in Sections 125 – 130.

124.2 Tests with receptacles that contain wire release mechanisms that activate more than one wire opening at a time, are to be tested with all single and multiple intended conductor combinations.

### 125 Pullout Test

125.1 A push-in (screwless) terminal for a factory-wired device for use with both solid and stranded conductors is to be tested as described in this Section and in Temperature Test, Section 126, using both solid and stranded conductors. Tests with stranded conductors are to include separate conductors for the maximum and minimum numbers of strands available in the wire sizes intended for use with the terminal in accordance with the manufacturer's instructions.

125.2 When tested with stranded conductors, all strands of the conductor must enter the terminal gripping area as intended without exposure of stray strands or reduction of required spacings.

125.3 A push-in (screwless) terminal shall withstand without pullout or breakage of the conductor, or of any strand of the conductor, the application of a straight pull for 1 minute as described in 125.4.

125.4 Six conductors of the intended size, either solid or stranded are to be connected to the terminals in accordance with the manufacturer's instructions. If both solid and stranded conductors are to be used, six of each type are to be tested. Each assembly is to be subjected to a pull on the wire that is to be gradually increased to 5 lbf (22 N).

## 126 Temperature Test

126.1 A push-in (screwless) terminal, for a factory-wired device, when tested as described in this Section, shall be capable of functioning without the temperature rise exceeding 30°C (54°F) based on an ambient temperature of 25°C (77°F).

126.2 For a factory-wired device, the size and type of conductors used are to be in accordance with the manufacturer's instructions. The maximum rated current is to be passed through the assemblies.

126.3 The assemblies described in 126.2 are to be tested for 30 days without interruption. The device temperature is to be measured at the end of each working day.

126.4 The test described in this section may be conducted in conjunction with the temperature test described in Section 107.

## 127 Conductor Insertion and Retention Test

127.1 A flush or self-contained receptacle having a 5-15R, 5-20R, 6-15R, or 6-20R configuration and provided with push-in terminals, when tested as outlined in 127.2 – 127.7 shall be capable of being wired properly without:

- a) Physical damage to the receptacle, including the terminals,
- b) Damage to the electrical insulation, or
- c) A reduction in spacings.

127.2 For one half of the receptacles, one line terminal and one neutral terminal on a receptacle rated 125 V, or one line terminal on each pole of a 250 V receptacle, are to be tested. On the remaining receptacles, terminals of the same polarity with the break-off tab between them removed to simulate a multiwire branch circuit installation, are to be tested. The receptacles are to be wired following the manufacturer's instructions. The stripped wire is to be inserted into the terminal as far as possible.

127.3 For terminals intended to receive one or more wires under the same spring, the terminals are to be tested in each of the following wiring configurations:

- a) One terminal with one wire in one wire entrance hole,
- b) One terminal with one wire in the other entrance hole, and
- c) One terminal with one wire in each of the two entrance holes, at the same time.

127.4 To determine compliance with 127.1 each tested terminal and wire combination is to be examined after the last wire insertion. The receptacles are to be subjected to a Dielectric Voltage-Withstand Test, as described in Section 60, except that the receptacles are not required to be subjected to the humidity conditioning described in 60.1.2. The test potential of 1000 volts plus twice the rated voltage is to be applied between:

- a) Live parts of opposite polarity, and
- b) Live parts and dead metal parts.

**UL COPYRIGHTED MATERIAL –  
NOT AUTHORIZED FOR FURTHER REPRODUCTION OR  
DISTRIBUTION WITHOUT PERMISSION FROM UL**

127.5 Each tested terminal and wire combination shall then withstand the application of a straight pull for 1 minute of the force in 127.6 without:

- a) Pullout or breakage of the conductor, or
- b) Any reduction in the electrical spacings at wiring terminals or within the device.

127.6 Each tested terminal is to be subjected to a pull on the wire that is to be gradually increased to 20 lbf (89 N) for a general-use device, or 5 lbf (22 N) for a factory-wired device.

127.7 At the completion of the test described in 127.6 there shall not be dielectric breakdown when each terminal is again tested as described in 127.4.

### 128 Conductor Push-In Test

128.1 The same flush and self-contained receptacles having a 5-15R, 5-20R, 6-15R, or 6-20R configuration used for the Conductor Insertion and Retention Test, Section 127, but with the original test wires removed, are to be tested for conductor push-in as described in 128.2, using newly stripped conductors as described in 128.3.

*Exception: For receptacles without a wire release mechanism, previously untested receptacles are to be used.*

128.2 As a result of inserting the test conductors, there shall not be:

- a) Interference with the insertion of an attachment plug, or
- b) Protruding of the test conductors through the device face or any other openings in the device body, or
- c) Contact with grounding or dead metal parts such as the mounting yoke, or
- d) Interference with the electrical connection between the contact and the blades or ground pin of a mating attachment plug, or
- e) Dielectric breakdown when tested as described in 127.4 and 127.5.

128.3 Previously unused lengths of solid copper wire are to be used. Strip 2 inches of the wire insulation. The bare wire is then to be inserted until the entire length is used or further insertion is not possible. Each terminal of a receptacle is to be tested. A force sufficient to fully insert the wire is to be applied.



## 129 Terminal Abuse Test

129.1 The same flush and self-contained receptacles having a 5-15R, 5-20R, 6-15R, or 6-20R configuration used for the conductor insertion and retention test and the conductor push-in test are to be tested as described in this section. The test conductors used in the previous tests are to be removed from the receptacles using the wire release mechanism.

*Exception: For receptacles without a wire release mechanism, previously untested receptacles are to be used.*

129.2 As a result of the test described in 129.3, there shall not be any breakage or distortion of the insulating body of the receptacle that:

- a) Would expose live parts to contact by a 1/32 inch (0.79 mm) diameter rod, or
- b) Results in reduction of electrical spacings to values less than those required for the receptacle.

129.3 Each receptacle is to be mounted in the test fixture shown in Figure 129.1 with its face in a vertical plane. The test pin shown in Figure 129.2 is then to be fully inserted into the "Push-In" terminal opening. An 8-ounce (0.23-kg) weight is to be gradually suspended from the test pin 6 inches (152 mm) from the plane of the terminal opening. The weight is to be applied for one minute, following which the weight is to be removed. The application of the weight is to be repeated with the receptacle rotated 90, 180 and 270 degrees for a total of four applications per receptacle.

Figure 129.1  
Test fixture

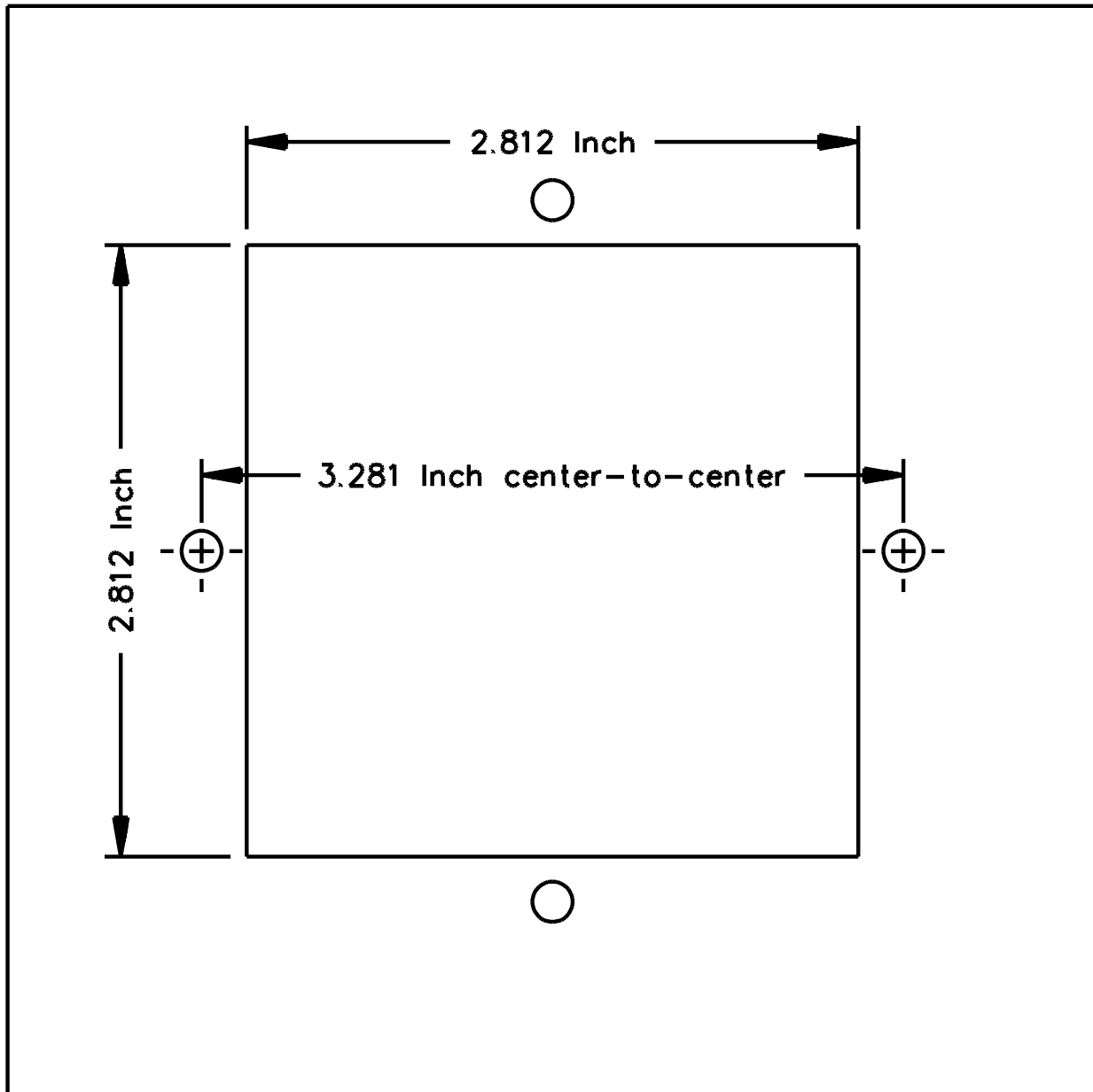

S3631

NOTE – Holes are tapped for No.6-32 Device Mounting Screws

*UL COPYRIGHTED MATERIAL –  
NOT AUTHORIZED FOR FURTHER REPRODUCTION OR  
DISTRIBUTION WITHOUT PERMISSION FROM UL*

**Figure 129.2**  
**14 AWG test pin**

Figure 129.2 revised November 16, 2007

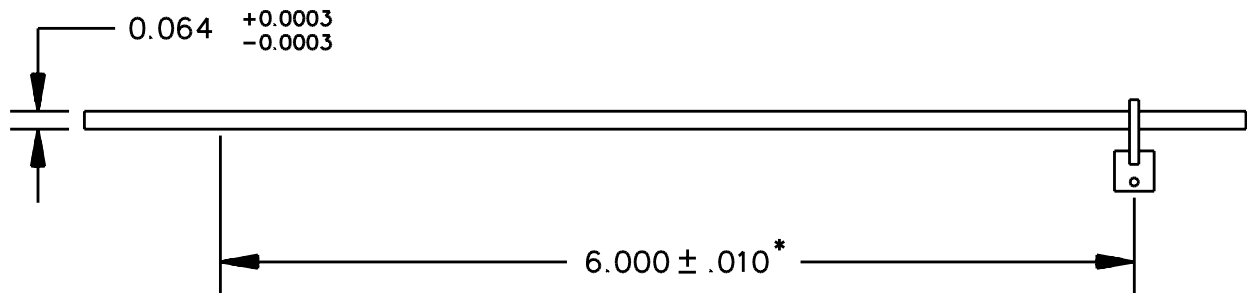

S3633

\*Measured from plane of opening in device

NOTE – Pin material – tool steel, nominal 1/16 drill rod

**UL COPYRIGHTED MATERIAL –  
NOT AUTHORIZED FOR FURTHER REPRODUCTION OR  
DISTRIBUTION WITHOUT PERMISSION FROM UL**

### 130 Temperature Test

130.1 A push-in terminal of a flush or self-contained receptacle having a 5-15R, 5-20R, 6-15R, or 6-20R configuration shall not have a temperature rise exceeding 30°C (54°F) based on an ambient temperature of 25°C (77°F) for each test described in this section.

130.2 Separate sets of previously unused receptacles are to be assembled with the conductor sizes and types described in Temperature Test, Section 107.

130.3 For terminals intended to receive one or more wires under the same spring, the terminals are to be tested in each of the following wiring configurations:

- a) One terminal with one wire in one wire entrance hole,
- b) One terminal with one wire in the other entrance hole, and
- c) One terminal with one wire in each of the two entrance holes, at the same time.

*Exception: For terminals intended to receive only a single wire under the same spring, only items (a) and (b) need be conducted.*

130.4 Each terminal assembly is to be conditioned by inserting and releasing a solid 14 AWG (2.1 mm<sup>2</sup>) conductor of the type to be used for the temperature test sequence. Four conductors, each approximately 18 – 24 inches (457 – 610 mm) long, are to be used. The conductors are to be installed in a standard single gang outlet box, mounted and located as shown in Figure 130.1, and securely clamped at the rear of the box so that the conductors extend from the box and form pigtail leads, each 6 to 6-1/2 inches (152 – 165 mm) long, measured from the clamp to the ends of the leads. All four pigtail leads are to be inserted in the push-in wiring terminals. After all the pigtail leads have been installed, each, in turn, is to be released and removed, then reinserted in the same terminal, prior to releasing the next pigtail lead, until all four pigtail leads have been released and reinserted. This sequence is to be repeated two additional times using the pigtail leads. The outlet box is not to be used for the fourth wire insertion described in 130.5.

*Exception No. 1: For devices not intended for through-wiring, only two conductors are to be used.*

*Exception No. 2: Receptacles without a wire release mechanism are not to be subjected to the repeated wire insertion and removal conditioning.*

130.4 revised November 16, 2007

130.5 A fourth insertion of a newly-stripped, previously unused length of solid 14 AWG (2.1 mm<sup>2</sup>) wire is to be made into each terminal and left in place. The length of each wire is to be between 24 – 27 inches (610 – 686 mm). Following the fourth wire insertion and prior to the temperature test sequence, each wire is to be subjected to a 20-lbf (89-N) pull applied in a direction perpendicular to the plane of the wire entry hole for 1 minute between the conductor and the receptacle without pullout or breakage of the conductor.

130.5 revised November 16, 2007

130.6 Following the pull test described in 130.5, the receptacles are to be mounted to the test frame shown in Figure 130.2 and wired in a series circuit as described in 130.7.

***UL COPYRIGHTED MATERIAL –  
NOT AUTHORIZED FOR FURTHER REPRODUCTION OR  
DISTRIBUTION WITHOUT PERMISSION FROM UL***

No Text on This Page

Document Was Downloaded By jianxiong chen For Use By KAI HUA (FOSHAN SHUNDE) ELECTRIC APPLIANCE CO LTD 22381 : 5/8/2008 - 10:34 AM

***UL COPYRIGHTED MATERIAL –  
NOT AUTHORIZED FOR FURTHER REPRODUCTION OR  
DISTRIBUTION WITHOUT PERMISSION FROM UL***

130.7 The temperature test sequence is to be conducted using the feed-through connections without passing current through the device contacts. The length of the test wire between terminals is to be 24 – 27 inches (610 – 686 mm) and the test wire is to project straight back from the device terminals for 3-1/2 – 4-1/2 inches (89 – 114 mm), at which point the test wire may continue to project straight back or may be formed in vertical coils 1 inch (25 mm) in diameter. The spacing between coils is to be varied to permit connections to terminals.

*Exception: A device without provisions for feed-through wiring, such as a single receptacle with provision for only one wire per terminal, is to be tested using a shorting jumper across the contacts. The shorting jumper is to consist of an attachment plug having solid blades and of the appropriate configuration whose terminals are connected together by the shortest possible length of wire of the same size being used to test the terminals.*

**UL COPYRIGHTED MATERIAL –  
NOT AUTHORIZED FOR FURTHER REPRODUCTION OR  
DISTRIBUTION WITHOUT PERMISSION FROM UL**

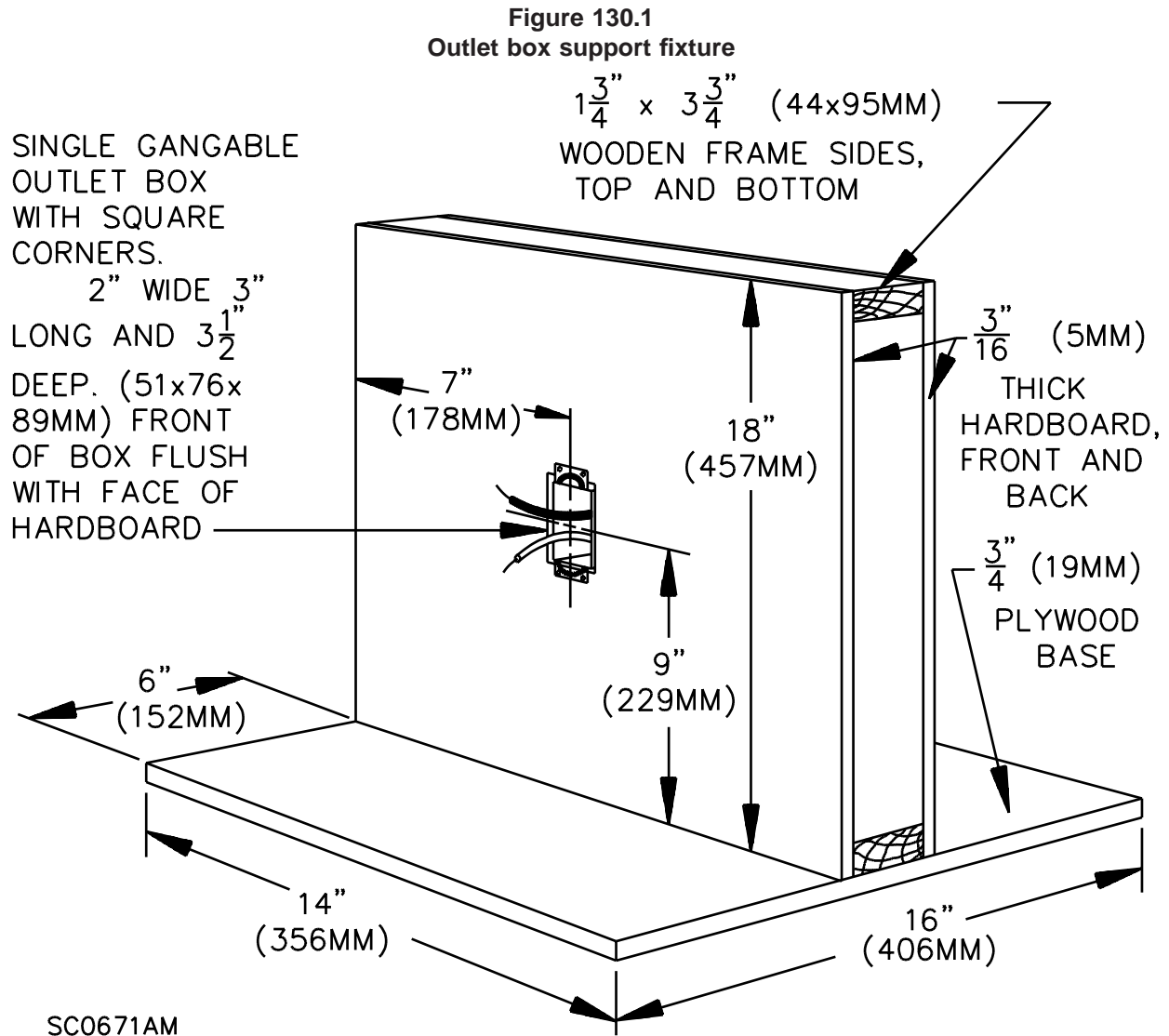

## NOTES

- 1) All dimensions are approximate.
- 2) The outlet box shall be securely fastened.
- 3) The fixture is to be placed on the floor during the test.

**UL COPYRIGHTED MATERIAL –  
NOT AUTHORIZED FOR FURTHER REPRODUCTION OR  
DISTRIBUTION WITHOUT PERMISSION FROM UL**



Figure 130.2  
Test fixture

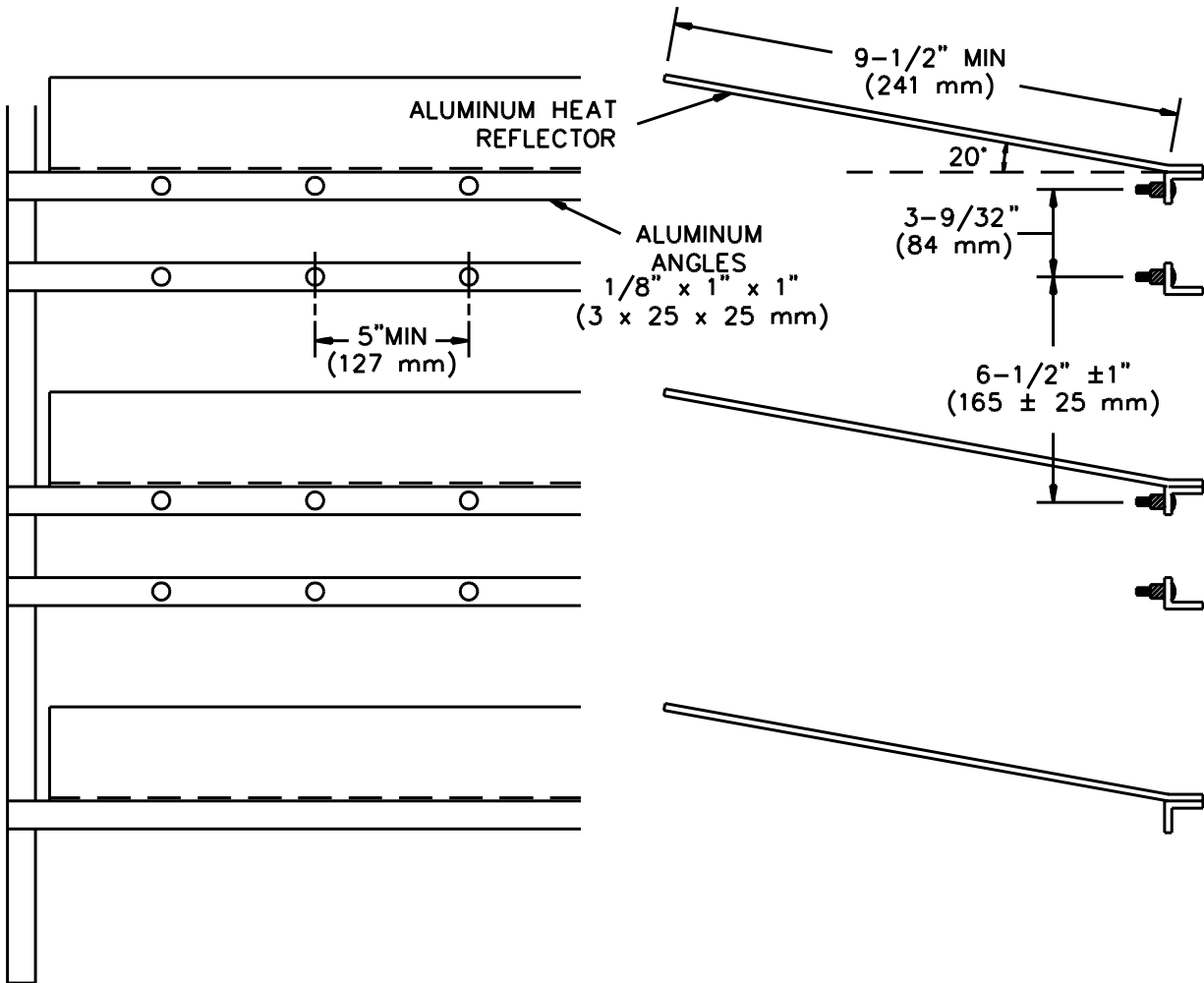

SB1640A

130.8 The temperature test sequence is to consist of:

- a) The temperature rise test described in 130.9 and 130.10,
- b) The current cycling conditioning described in 130.11,
- c) The wire disturbance conditioning described in 130.12, and
- d) The temperature rise test repeated again.

Each tested receptacle is to be subjected to the tests in the order described.

130.9 Temperatures are to be measured using thermocouples attached to a bare conductor adjacent to the insulation edge when the conductor is stripped to the maximum recommended length. See 107.7. Temperatures are also to be measured on the break-off tabs, if provided. See 107.9.

130.10 The test current is to be 15 A. The temperature rise test is to continue until thermal stabilization is attained. Thermal stabilization is considered to have occurred when three successive readings, taken at intervals of not less than 10 minutes, show no further increases.

130.11 The current cycling conditioning is to consist of 168 four hour cycles. Each cycle is to consist of 3-1/2 hours with current and 1/2 hour without current. The cycling current is to be 22.5 A.

130.12 Following the heat cycling conditioning, the aluminum heat reflector panels are to be removed and each connected wire is to be subjected to a wire disturbance conditioning. In conducting the wire disturbance conditioning the test wire connected to each device terminal is to be gripped approximately 4 inches (102 mm) from the terminal. The test wire is then to be moved firmly and with a smooth motion downward from the horizontal plane through an arc of approximately 90 degrees so that the wire assumes a vertical orientation. The wire is then to be moved upward so that the wire is returned to the horizontal position. The bending operation is to be repeated, except that the test wire for each set of two receptacles is to be moved in a different direction from the other sets either left, right, up, or down, and then returned to the initial position, so that each connection to the receptacle under test is subjected to two successive applications of a force exerted in one or more directions during manipulation of the test wire. Care is to be exercised so that during the manipulation, pulling or twisting forces are not applied to the wire and adjacent receptacles are not disturbed. The heat reflector panels are to be reinstalled after the wire manipulation has been completed.

Tamper-Resistant Receptacles

**131 General**

131.1 In addition to the general performance requirements for receptacles, tamper-resistant receptacles shall comply with the requirements in Sections 132 – 135.

**132 Probe Test**

132.1 A tamper-resistant receptacle shall not permit contact to be made between the probe shown in Figure 132.1 and any live part of the receptacle through the outlet slots when tested as described in this section.

132.2 Twelve previously untested devices are to be used for this test. The probe is to be applied to each of the outlet slot openings of the receptacle with a force of 8 ounces (1 N) in an attempt to bypass the tamper-resistance mechanism. A suitable indicating device (such as an ohmmeter, battery-and-buzzer combination, or the like) is to be connected between the probe and the wiring terminal of the outlet slot being tested to determine whether contact is made. The probe is to be manipulated in the outlet slots in any orientation that may permit access to live parts within the receptacle.

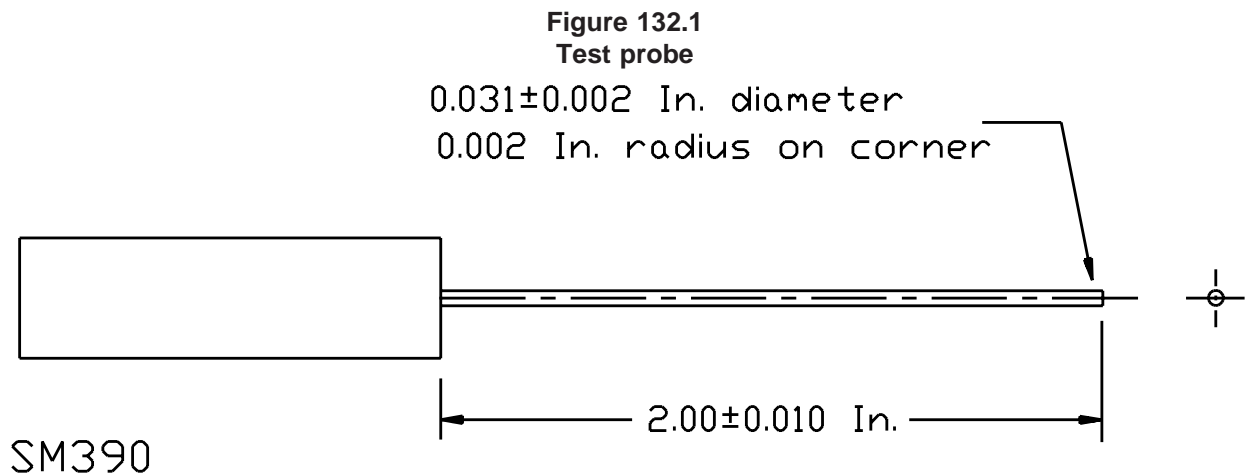

MATERIAL: Tool Steel, Rockwell Hardness C58 to C60

inch	0.031 ±0.002	2.00 ±0.010
mm	0.787 ±0.051	50.8 ±0.25

**UL COPYRIGHTED MATERIAL –  
NOT AUTHORIZED FOR FURTHER REPRODUCTION OR  
DISTRIBUTION WITHOUT PERMISSION FROM UL**

## 133 Impact Test

### 133.1 General

133.1.1 A tamper-resistant receptacle shall withstand either the ball-pendulum impact or the vertical-ball impact described in this section without breakage of the receptacle face or tamper-resistance mechanism or any other damage that could increase the risk of fire or electric shock as determined in 133.1.2. The receptacle shall be capable of functioning as intended after completion of the test.

133.1.2 Upon completion of this test, each device shall be:

- a) Capable of completely mating with the intended attachment plugs (both grounding and nongrounding types, rated 15 and 20 A, where applicable);
- b) Subjected to a repeated Probe Test described in Section 132; and
- c) Subjected to the Dielectric Voltage-Withstand Test described in Section 135.

133.1.3 Six devices which were previously subjected to the Probe Test are to be used. One outlet face of each of the six devices is to be subjected to a single impact by a steel sphere, 2 inches (50.8 mm) in diameter, and weighing 1.18 lbs (0.535 kg) by either of the methods specified in 133.2 or 133.3.

### 133.2 Ball-pendulum impact

133.2.1 Each device is to be mounted in a single gangable metallic flush outlet box fastened to a frame as shown in Figure 133.1. A nonmetallic flush device cover plate is to be installed on the receptacle in the intended manner. The frame shown in Figure 133.1 is to be clamped firmly in place or otherwise provided with rigid support to not permit movement during the application of the impact force.

133.2.2 The steel sphere is to be suspended by a cord and swung as a pendulum as shown in Figure 133.2, dropping through a vertical distance of 51 inches (1295 mm) to strike the outlet face surface of the receptacle with an impact of 5.0 ft-lb (6.8 joules). For duplex receptacles, three devices are to be tested using one outlet, and three using the other.

Figure 133.1  
Test frame

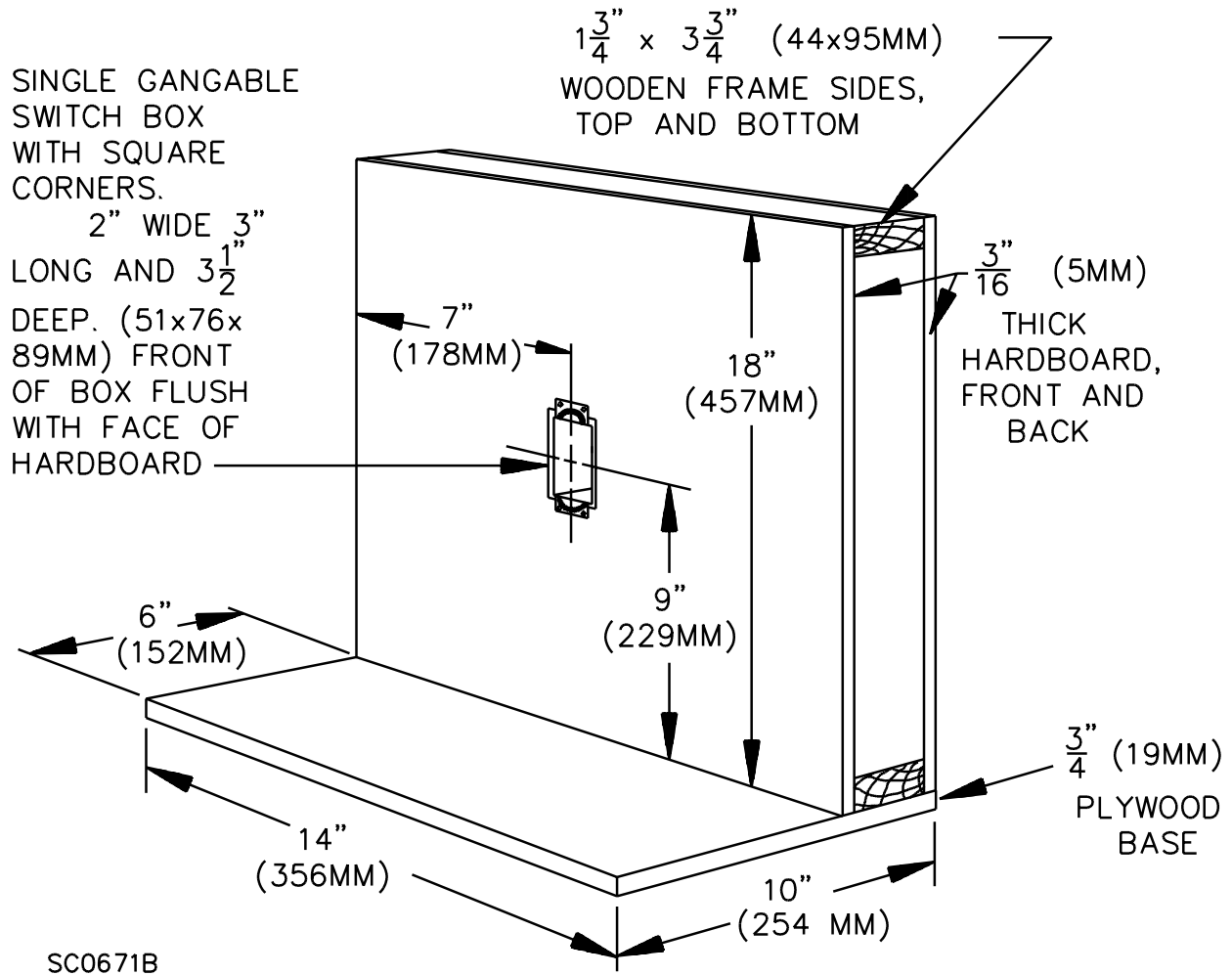

UL COPYRIGHTED MATERIAL –  
NOT AUTHORIZED FOR FURTHER REPRODUCTION OR  
DISTRIBUTION WITHOUT PERMISSION FROM UL

Figure 133.2  
Ball-pendulum impact test

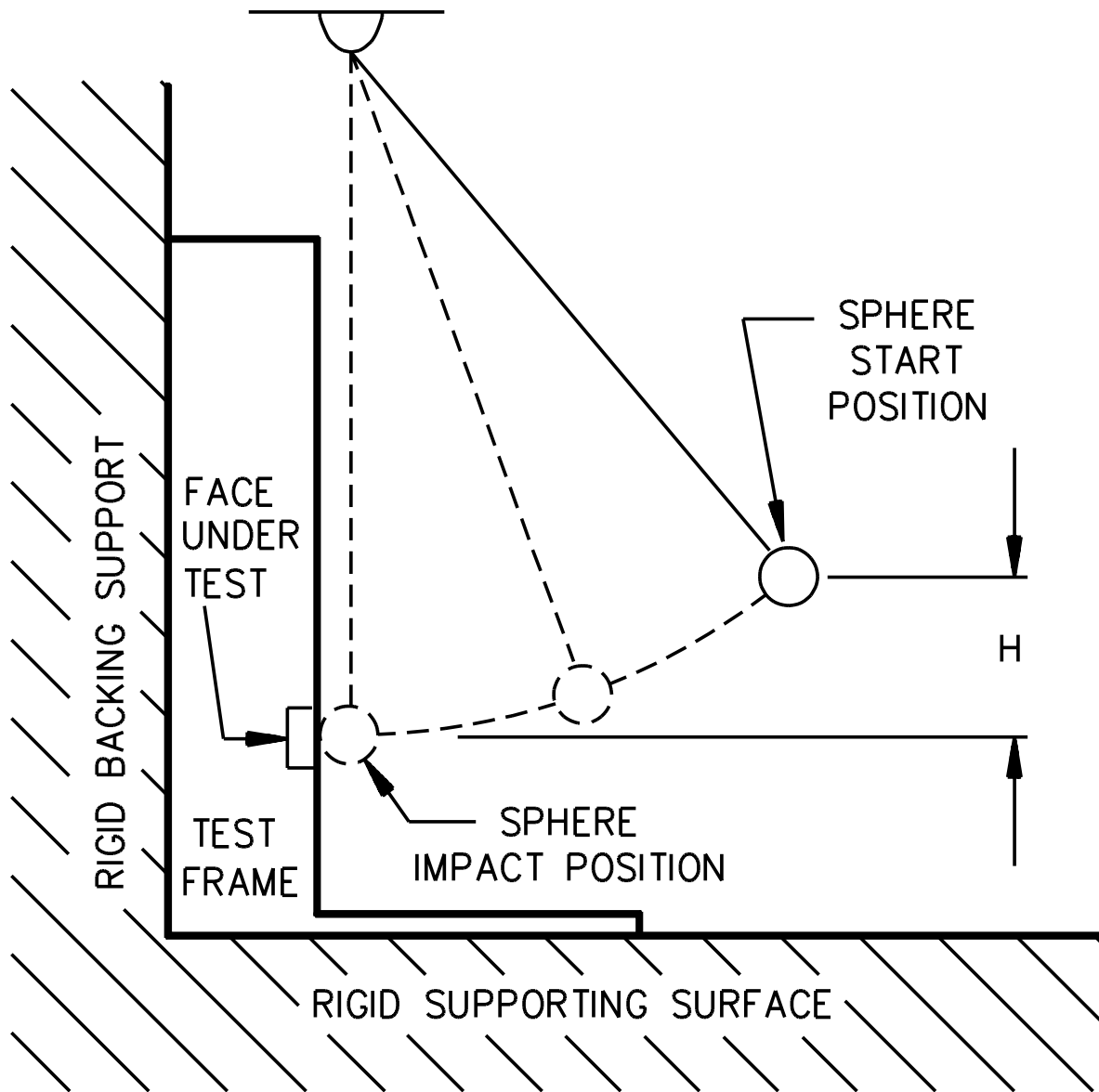

SM389

NOTES

- 1) H indicates a vertical distance of 51 inches (1295 mm).
- 2) For the ball-pendulum impact test the sphere is to contact the device when the string is in the vertical position as shown.
- 3) The backing surface is to consist of 3/4-inch (19 mm) plywood over a rigid surface of concrete. An equivalent non-resilient backing surface may be used.

**UL COPYRIGHTED MATERIAL –  
NOT AUTHORIZED FOR FURTHER REPRODUCTION OR  
DISTRIBUTION WITHOUT PERMISSION FROM UL**

### 133.3 Vertical-ball impact

133.3.1 The devices are to be mounted to a cast metal (malleable iron) outlet box and a nonmetallic flush-device cover plate is to be installed on the receptacle in the intended manner. The receptacle, faceplate, and box are to be placed on a steel plate at least 1/2 inch (12.7 mm) thick with the outlet facing upward.

133.3.2 The steel sphere is to be dropped from a height of 51 inches (1295 mm) to impact the center of each receptacle outlet as shown in Figure 133.3. For duplex receptacles, three devices are to be tested using one outlet, and three using the other.

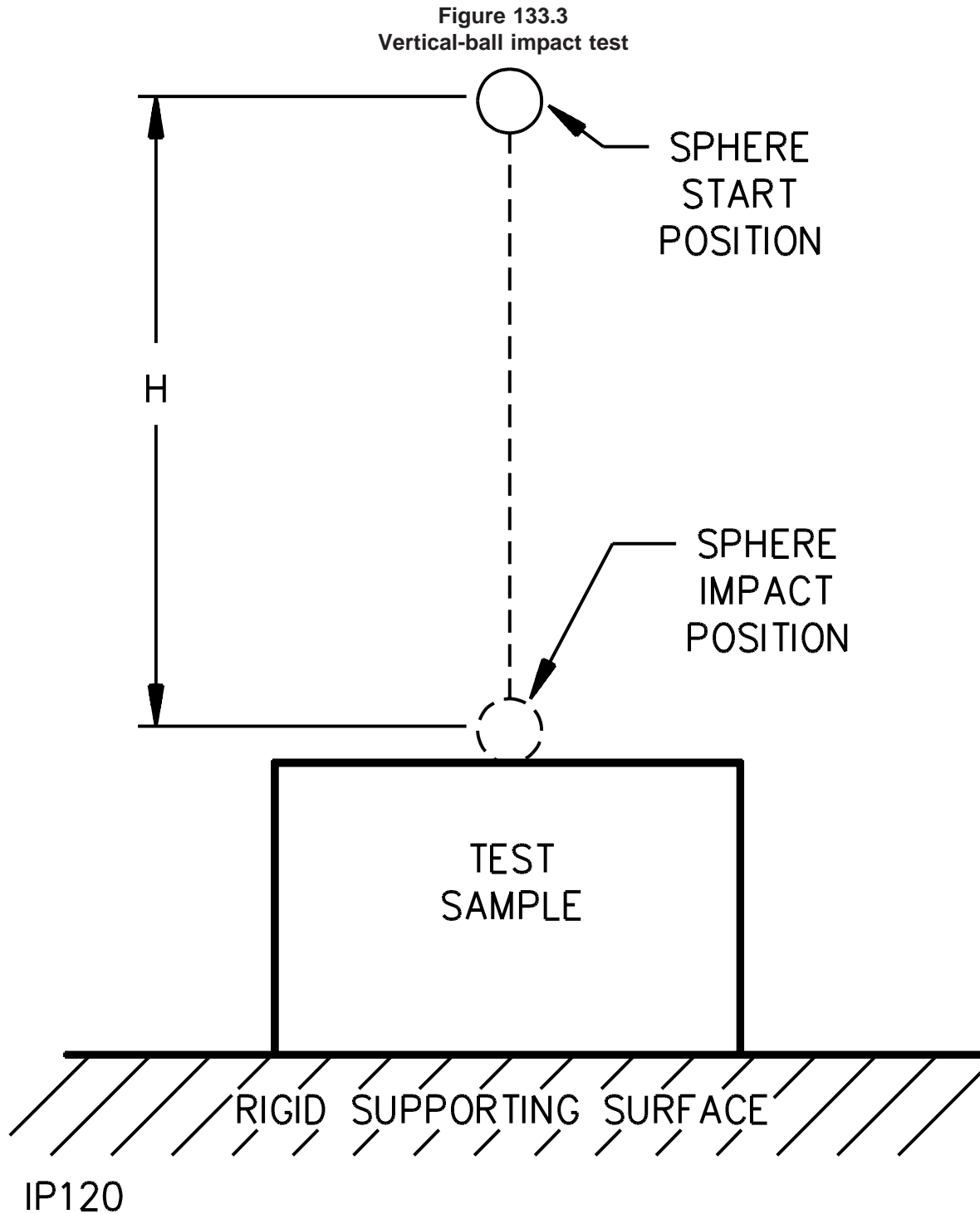

## NOTES

- 1)  $H$  indicates a vertical distance of 51 inches (1295 mm).

**UL COPYRIGHTED MATERIAL –  
NOT AUTHORIZED FOR FURTHER REPRODUCTION OR  
DISTRIBUTION WITHOUT PERMISSION FROM UL**



### 134 Mechanical Endurance Test

134.1 At the completion of this test, there shall not be any chipping, breaking or loosening of parts that could adversely affect the functioning of the device as determined in 134.2. The tamper-resistance mechanism shall be capable of performing its intended function.

134.2 Upon completion of this test, each device shall be:

- a) Capable of completely mating with the intended attachment plugs (both grounding and nongrounding types, rated 15 and 20 A, where applicable);
- b) Subjected to a repeated Probe Test described in Section 132; and
- c) Subjected to the Dielectric-Voltage Withstand Test described in Section 135.

134.3 Six devices which were previously subjected to the Probe Test described in Section 132 are to be used. One outlet face of each device is to be tested by inserting and withdrawing 5,000 times an attachment plug having rigidly secured solid brass blades. When an equipment-grounding connection is provided in the device being tested, a grounding-type attachment plug is to be used. For duplex receptacles, three devices are to be tested using one outlet, and three using the other.

134.4 The test is to be conducted by machine. The machine is to withdraw and insert an unrestricted attachment plug with an average velocity of  $30 \pm 3$  inches/sec ( $760 \pm 75$  mm/sec) in each direction during a 2-1/2 inch (64 mm) stroke measured from the full insertion position. The velocity is to be determined without the outlet device installed on the machine to remove restrictions on the plug motion.

134.5 Blades, contacts or tamper-resistance mechanisms are not to be adjusted, lubricated, or otherwise conditioned before or during the test. The attachment plug used for this test may be changed after each 1000 cycles.

### 135 Dielectric Voltage-Withstand Test

135.1 A tamper-resistant receptacle shall withstand without breakdown, for a period of one minute, the application of a 60 Hz essentially sinusoidal potential equal to twice the rated voltage of the receptacle plus 1000 V. The potential is to be applied between live parts of opposite polarity and between live parts and grounded or dead metal parts, including the mounting yoke of the receptacle.

135.2 Six devices which were previously subjected to the Probe and Impact Tests and six devices which were previously subjected to the Probe and Mechanical Endurance Tests are to be used. A mating attachment plug with solid brass blades is to be inserted into the contact openings of three of the six devices. The attachment plug shall be capable of withstanding the application of a 2500 V potential for devices rated 300 V or less and a 3500 V potential for devices rated greater than 300 V. The test potential is to be supplied from a 500 VA or larger capacity testing transformer whose output is essentially sinusoidal and can be varied. The applied potential is to be increased from zero until the required test voltage is reached and is to be held at that voltage for a period of one minute. The increase in the applied potential is to be at a uniform rate and as rapid as is consistent with its value being correctly indicated by a voltmeter.

## Pin-Type or Insulation-Displacement Terminals

### 136 General

136.1 In addition to the general performance requirements for receptacles, receptacles employing pin-type or insulation-displacement terminals shall comply with the requirements in Section 137.

### 137 Heat Cycling and Vibration Tests

#### 137.1 General

137.1.1 Following the Heat Cycling and Vibration Tests described in this section, each fixture, equipment, or appliance outlet have pin-type or insulation-displacement terminals shall comply with the thermal stability criteria described in 137.5.1 and not have demonstrated a temperature rise of more than 100°C (180°F).

137.1.2 Following the manufacturer's instructions, six representative fixture, equipment, or appliance outlets are to be assembled onto the wire of the size and type recommended by the manufacturer. Solid copper wire is to be used unless otherwise specified in the instructions.

137.1.3 The devices are to be connected with 24 to 27 inches (610 to 686 mm) of cable between each device and wired in series so that the test current passes through the connection point of the entering conductor, the device internal structure, and the exiting conductor.

137.1.4 Three of the devices are to be mounted to a test rack constructed of cast-iron angles not smaller than 1/8 by 1-1/4 by 1-1/4 inch (3.2 by 31.8 by 31.8 mm) welded to form a rigid assembly. Mounting holes are to be provided for attachment of the test rack to a vibration platform.

137.1.5 The contacts of the devices under test are to be connected together by means of an attachment plug inserted therein. The plug is to have rigidly attached blades, and the terminals of the plug are to be short-circuited by means of the shortest feasible lengths of Type T or Type RH wire.

#### 137.2 Heat cycling test

137.2.1 Each heating cycle is to consist of 1-1/2 hours "on" time and 1/2 hour "off" time with a total of 500 cycles on each device. The test current is to equal 200 percent of the current rating of the device.

137.2.2 The temperature rises are to be measured using thermocouples placed on the blades of the attachment plug, as close as possible to the face of the plug.

137.2.3 Temperature readings are to be obtained by means of thermocouples consisting of 28 – 32 AWG (0.08 – 0.032 mm<sup>2</sup>) iron and constantan wires. It is a common practice to employ thermocouples consisting of 30 AWG (0.05 mm<sup>2</sup>) iron and constantan wires with a potentiometer type of indicating instrument. This equipment is to be used if a referee measurement of temperature is necessary.

137.2.3 revised November 16, 2007

137.2.4 The temperature of the connection is to be recorded at the following intervals: commencing with the 25th cycle and approximately every 25 cycles thereafter for a total of five measurements (approximately 125 cycles). This yields 5 data points for each device tested.

No Text on This Page

Document Was Downloaded By jianxiong chen For Use By KAI HUA (FOSHAN SHUNDE) ELECTRIC APPLIANCE CO LTD 22381 : 5/8/2008 - 10:34 AM

***UL COPYRIGHTED MATERIAL –  
NOT AUTHORIZED FOR FURTHER REPRODUCTION OR  
DISTRIBUTION WITHOUT PERMISSION FROM UL***

### 137.3 Vibration test

137.3.1 Following approximately 125 cycles of heat cycling as described in 137.2.1 – 137.2.4, the three devices mounted to the test rack are to be disconnected from the circuit and subjected to vibration testing as described in 137.3.2.

137.3.2 Each device mounted to the test rack is to be fastened to a vibration platform and subjected to the following conditioning:

- a) Simple harmonic motion of amplitude 0.03 inch (0.76 mm), 0.06 inch (1.52 mm) peak-to-peak, with the frequency varied uniformly in one minute from 10 to 55 and back to 10 cycles per second.
- b) Vibration applied for two hours in each of three mutually perpendicular directions for a total of 6 hours of testing.

137.3.3 At the conclusion of the vibration conditioning, each device is to be reconnected to the test circuit to complete the approximately 375 remaining cycles of the Heat Cycling Test, as described in 137.4.1, for a total of 500 cycles.

### 137.4 Heat cycling test (Continued)

137.4.1 The remaining 6 data points for each device are to be obtained by recording the temperature of the connection at the following intervals:

- a) Approximately every 45 cycles for a total of three measurements (approximately 135 cycles), and then
- b) Approximately every 80 cycles for a total of three measurements (approximately 240 cycles).

### 137.5 Calculations

137.5.1 The thermal stability is to be evaluated as follows: for each thermocouple location

- a) Find the average temperature rise for all 11 data points obtained (from 137.2.4 and 137.4.1), and
- b) Find the deviation of each of the 11 data points from the calculated average.

None of the 11 data points shall deviate above the average temperature by more than 10°C (18°F). There shall not be a temperature rise greater than 100°C (180°F) above the room ambient temperature on any device during the heat cycling test.

## Self-Contained Receptacles

### 138 General

138.1 In addition to the general performance requirements, a self-contained receptacle shall comply with the requirements in Sections 139 – 150 as specified in Table 54.5.

138.2 For self-contained receptacles employing insulation displacement terminals, the Temperature Test, Section 107 is to be performed following the Pullout Test in Section 140.

### 139 Heat Cycling and Vibration Tests

#### 139.1 General

139.1.1 Following the Heat Cycling and Vibration Tests described in this section, a self-contained receptacle shall:

- a) Meet the thermal stability criteria described in 139.4.1 and
- b) Not have displayed a temperature rise of more than 100°C (180°F).

*Exception: Self-contained receptacles for connection to only copper wire employing crimp, screw-terminal, or pressure-wire connector constructions are not required to be tested for heat cycling or vibration.*

139.1.2 Ten self-contained receptacles rated 15 A are to be assembled onto two conductor 14 AWG nonmetallic sheathed cable with ground and copper conductors. Ten devices rated 20 A are to be assembled onto two-conductor 12 AWG nonmetallic sheathed cable with ground and copper conductors.

139.1.2 revised November 16, 2007

139.1.3 The devices are to be connected with 24 to 27 inches (610 to 686 mm) of cable between each device and wired in series so that the test current passes through the connection point of the entering conductor, the device internal structure, and the exiting conductor. See 139.2.2 and 139.2.3 (mentioning splice and nonsplice connections). See 139.3.2 – 139.3.4 for devices to be vibration tested.

## 139.2 Heat cycling test

139.2.1 Each heating cycle is to consist of 1-1/2 hours "on" time and 1/2 hour "off" time with a total of 500 cycles on each device. The test current is to be 53 A for those devices being tested with 12 AWG cable and 40 A for those devices being tested with 14 AWG cable.

139.2.1 revised November 16, 2007

139.2.2 The temperature rises are to be measured using thermocouples placed on the internal wire termination structure, as close as practicable to the wire termination point. If the design of the device is such that splicing connections are intended (see manufacturer's instructions) all devices are to be so wired using the minimum number of possible connection points for each wire (a splicing connector is where the incoming wires terminate in the device and a second set of conductors originate in the same device).

139.2.3 If a splicing connection is not intended, modified devices may be necessary so that unrelated variables will not influence the test results. For example, the line and neutral wire terminations may have to be jumped by a 14 AWG (2.1 mm<sup>2</sup>) copper wire soldered in place or 12 AWG (3.3 mm<sup>2</sup>) copper wire for devices tested with No. 12 wire, or an equivalent means. Modifications are not to provide any increase in overall thermal or electrical conductivity, mechanical strength, and so forth, beyond that of the basic unmodified device construction.

139.2.3 revised November 16, 2007

139.2.4 The temperature of the connection is to be recorded at the following intervals, which may be approximate:

- a) Commencing with the 25th cycle and every 25 cycles thereafter for a total of five measurements (125 cycles),
- b) Then every 45 cycles for a total of three measurements (135 cycles), and finally
- c) Every 80 cycles for a total of three measurements (240 cycles).

This yields a total of 11 data points for each device tested.

139.2.5 Temperature readings are to be obtained by means of thermocouples consisting of 28 – 32 AWG (0.08 – 0.032 mm<sup>2</sup>) iron and constantan wires. It is a common practice to employ thermocouples consisting of 30 AWG (0.05 mm<sup>2</sup>) iron and constantan wires with a potentiometer type of indicating instrument. This equipment will be used if a referee measurement of temperature is necessary.

139.2.5 revised November 16, 2007

### 139.3 Vibration test

139.3.1 Following approximately 125 cycles of heat cycling (as described in 139.2.1 – 139.2.5), six devices from each group of ten (for a total of 12) are to be disconnected from their circuit and subjected to vibration conditioning.

139.3.2 Five of each of the six devices are to be mounted (prior to the start of the Heat Cycling Test) to a special test rack constructed of cast-iron angles not smaller than 1/8 by 1-1/4 by 1-1/4 inch (3.2 by 31.8 by 31.8 mm) welded to form a rigid assembly. Mounting holes are to be provided for attachment to the vibration platform. Insulating strips or clamps are to be provided to secure the wires between devices at 6 – 8 inches (152 – 203 mm) from the point at which they exit the device, and located in the same plane as the mounting means for the device.

139.3.3 The devices are to be rigidly mounted to the fixture by their mounting means. Equivalent methods of mounting such as bolting or clamping the devices to the frame may be used.

139.3.4 The sixth device of each group is to be mounted by its normal mounting means in the center of a 21 inch square (533 mm square) piece of panel board having the minimum intended thickness for use with the device. The panel board is then to be bolted to a test rack similar to that described in previous paragraphs but sized so that the panel board is supported around its periphery (approximately 21 inches on each side). Clearance holes through the test rack are to be provided for the test wires opposite where they exit the device. Additional support for the test wire is not to be provided.

139.3.5 Each device is then to be subjected to the following vibration conditioning.

- a) Simple harmonic motion of amplitude 0.03 inch (0.06 inch peak-to-peak) with the frequency varied uniformly between 10 and 55 and back to 10 cycles per second in one minute.
- b) Vibration applied for two hours in each of three mutually perpendicular directions for a total of 6 hours of testing.

139.3.6 At the conclusion of the Vibration Test in 139.3.1 – 139.3.5, all test devices are to be reconnected to their respective circuits to complete the remaining 375 cycles of the Heat Cycling Test (for a total of 500 cycles).



### 139.4 Calculations

139.4.1 The thermal stability is to be evaluated as follows: for each thermocouple's location;

- a) Find the average temperature rise for all 11 data points obtained (from 139.2.4) and
- b) Find the deviation of each of the 11 data points from the calculated average.

None of the 11 data points shall deviate above the average temperature by more than 10°C (18°F). There shall not be a temperature rise greater than 100°C (180°F) above the room ambient temperature on any device during the Heat Cycling Test.

### 140 Cable Pullout Test

140.1 After being subjected to the Cable Pullout Test in 140.2, a self-contained receptacle shall not exhibit:

- a) Any visible indications of conductor pullout,
- b) Damage to the cable insulation, or
- c) Any loosening of the assembly that would enable the cable to be removed by flexing or bending following the removal of the test force.

140.2 Six receptacles rated 15 A are to be installed onto two-conductor 14 AWG copper cable with ground, and six receptacles rated 20 A installed onto 12 AWG copper cable with ground. The cable installation is to be in accordance with the manufacturer's instructions. Wiring terminals having a screw-actuated clamping means are to be fully tightened and then loosened one full turn before application of the test force. Each cable is then to be subjected to a force of 60 lbf (267 N) applied perpendicular to the plane of the cable entrance (along the wire) for five minutes. Devices are to be rigidly supported by their mounting means during testing.

140.2 revised November 16, 2007

### 141 Conductor Pullout Test

141.1 Following the test pull described in 141.2, no conductor shall be displaced from its connection or connections to a self-contained receptacle.

141.2 Three devices rated 15 A are to be installed with a single 14 AWG (Type TW) copper conductor connected to each terminal. Three devices rated 20 A are to be similarly installed but with a single 12 AWG copper Type TW conductor connected to each terminal. Each conductor is to be subjected to a pull of 20 lbf (89 N) gradually applied perpendicular to the plane of the wire entrance hole (along the wire) and sustained for 1 minute. Any parts necessary for proper installation of wire in the termination are to be used.

141.2 revised November 16, 2007

## 142 Mounting Strength Test

### 142.1 General

142.1.1 Following the test in 142.4.1, a self-contained receptacle shall not exhibit:

- a) A permanent displacement of more than 1/8 inch (3.18 mm) from the plane of the wall; or
- b) Any damage which might adversely affect the intended function of the device.

### 142.2 Receptacles mounted directly in panels

142.2.1 Six self-contained receptacles that are intended to be directly mounted in paneling are to be installed in a test wall made using paneling of the minimum thickness for which the device is intended. The paneling is to be supported (typically with a stud) 6 inches (152 mm) from one edge of the opening in which the device is to be installed. Each of the receptacles is then to be tested as described in 142.4.1.

### 142.3 Receptacles supported by mounting brackets

142.3.1 Each of six self-contained receptacles that is intended to be supported from a frame construction mounting bracket is to be installed as intended and tested as described in 142.4.1.

### 142.4 Testing

142.4.1 Testing is to be accomplished as follows:

- a) A 50 lbf (222 N) is to be applied for a period of 5 minutes to each of two devices in a direction perpendicular to the face of the mounting surface along the center line of the receptacle, tending to push it into the mounting opening.
- b) A 50 lbf (222 N) is to be applied to each of two previously untested receptacles as described in (a) above but in the opposite direction (tending to pull the receptacle out of the opening).
- c) A 60 lbf (267 N) is to be applied to the nonmetallic sheathed cable of each of two previously untested devices in a downward direction from where the cables exit.

### 143 Wall-Mounting Secureness Test

143.1 A self-contained receptacle intended to be installed in a wall without the support of a frame-construction mounting bracket is to be tested as described in this section. After testing, each device shall remain secure to the extent that there is no displacement of the device, with respect to the wall, exceeding 1/4 inch (6.35 mm).

143.2 Three devices are to be tested following their installation, as shown, in the test wall illustrated in Figure 143.1. Three devices are to be tested similarly but with the receptacle installed in a direction perpendicular to that of the first 3 devices. Each device is to be attached, without the nonmetallic cable installed, to the test wall in accordance with the instructions provided by the manufacturer. An eyelet is to be fastened to the face of the device for the purpose of attaching the test wire and applying the test force. The eyelet may be bolted, cemented, or otherwise fastened. The device may be altered to accommodate the eyelet provided that it does not affect test results.

143.3 A force of at least 22 lbf (97.8 N) is to be applied consecutively in opposite directions at an angle of  $30 \pm 2$  degrees from the face of the wall as illustrated in Figure 143.2. The force is to be abruptly applied within 0.10 seconds and maintained for at least 0.40 second before it is abruptly removed. Two consecutive pulls, one in each direction, constitute one test cycle. The test is to be conducted for 5000 cycles at a rate of 30 – 60 cycles per minute.

### 144 Assembly Security Test

#### 144.1 General

144.1.1 Following the Assembly Security Tests in 144.2 and 144.3 (Methods A and B, respectively) there shall not be any mechanical breakage of a self-contained receptacle or separation of the face and rear portions that would interfere with the intended functioning of the device.

144.1.2 The receptacles are to be examined for compliance with 144.1.1 within 5 minutes after the removal of the force.

#### 144.2 Method A

144.2.1 Three self-contained receptacles are to be mounted as illustrated in Figure 144.1. A 100 lbf (445 N) is to be applied as shown by means of a rigid steel push-out tool, as illustrated in Figure 144.2, inserted into the slots of the receptacles.

Figure 143.1  
Test wall

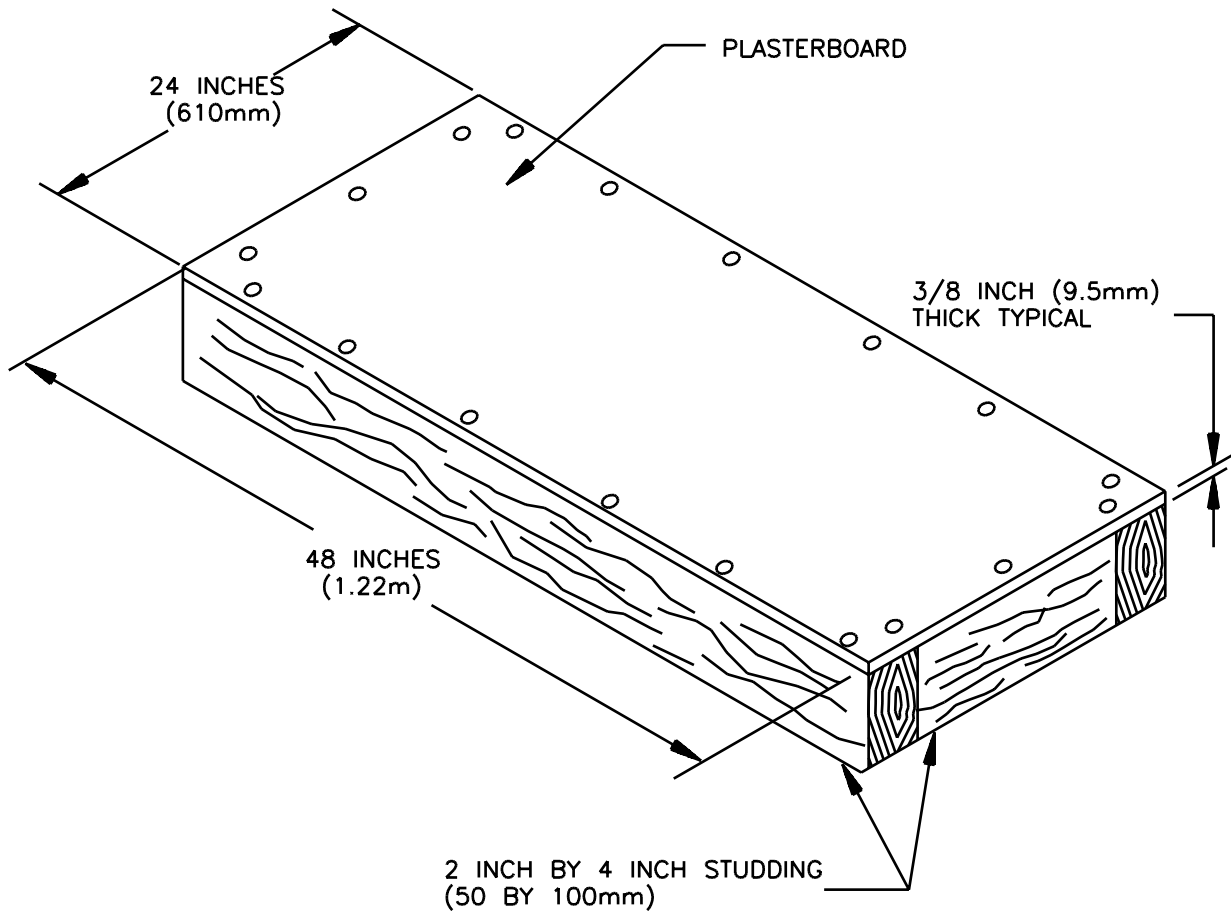

S3334

UL COPYRIGHTED MATERIAL –  
NOT AUTHORIZED FOR FURTHER REPRODUCTION OR  
DISTRIBUTION WITHOUT PERMISSION FROM UL

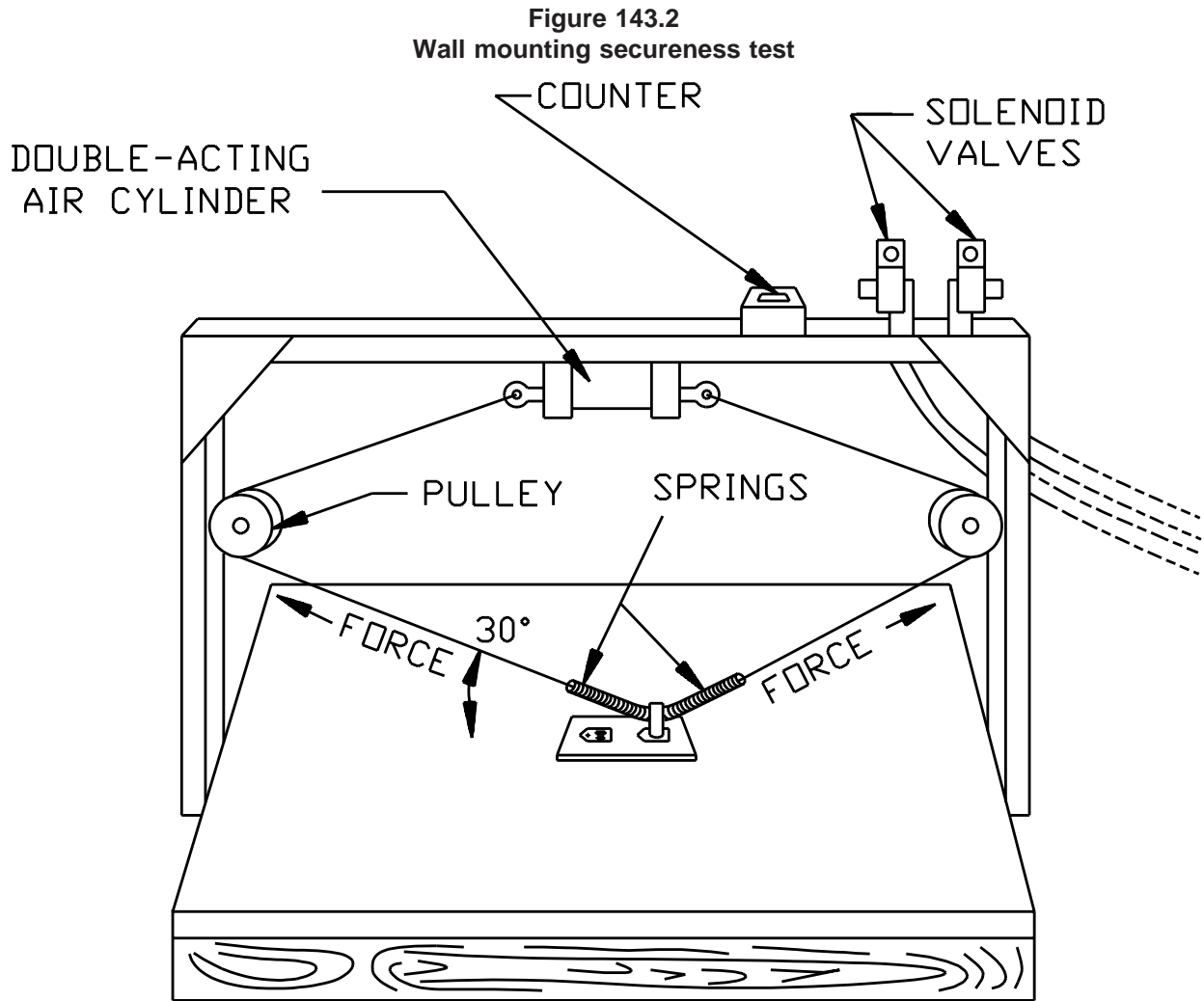

S3333

NOTE – The springs shown above have the following characteristics:

- a) Free (unexpanded) length of 4 inches (102 mm),
- b) Outer diameter of 1 inch (25 mm),
- c) Wire diameter of 0.105 inch (2.7 mm), and
- d) Spring constant of 11.5 lb/in (205 g/m).

**UL COPYRIGHTED MATERIAL –  
NOT AUTHORIZED FOR FURTHER REPRODUCTION OR  
DISTRIBUTION WITHOUT PERMISSION FROM UL**

Figure 144.1  
Application of assembly security test

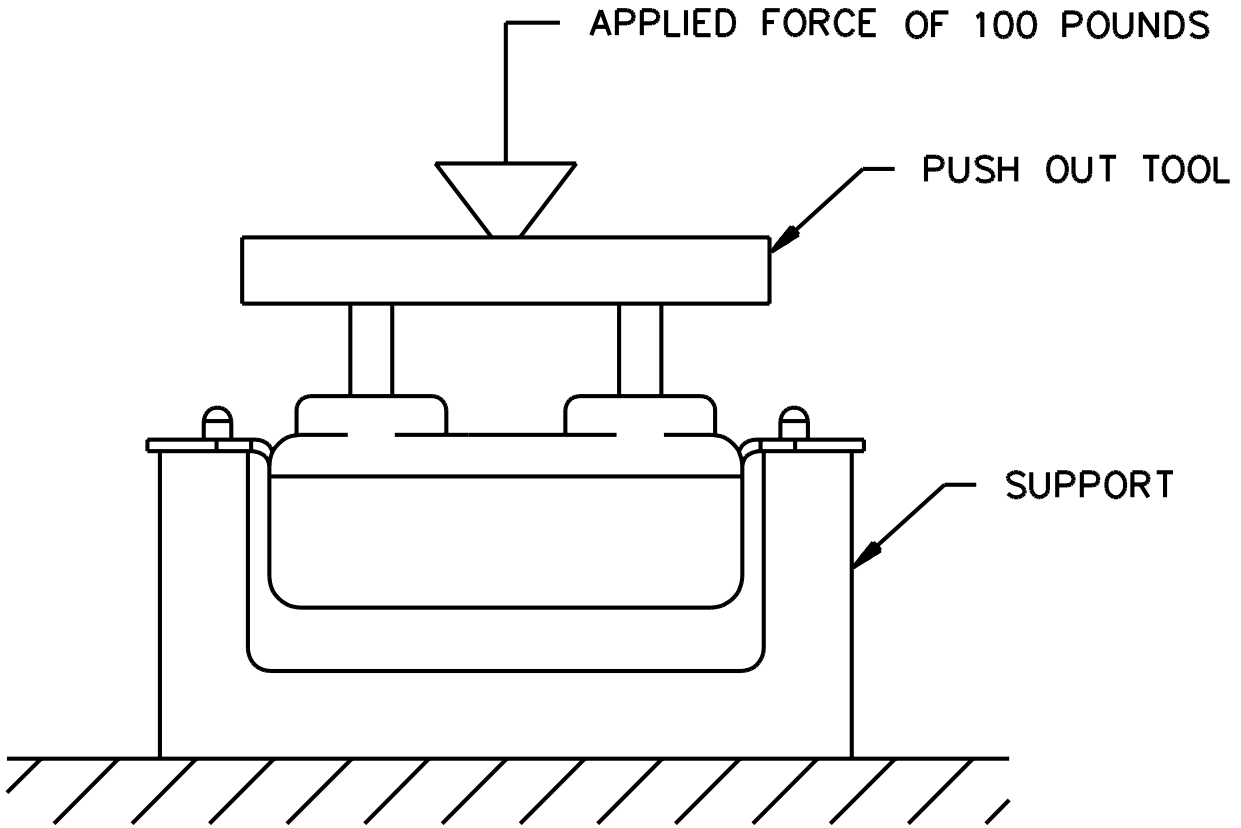

S3637B

Figure 144.2  
Fixture for assembly security test

(All dimensions in inches)

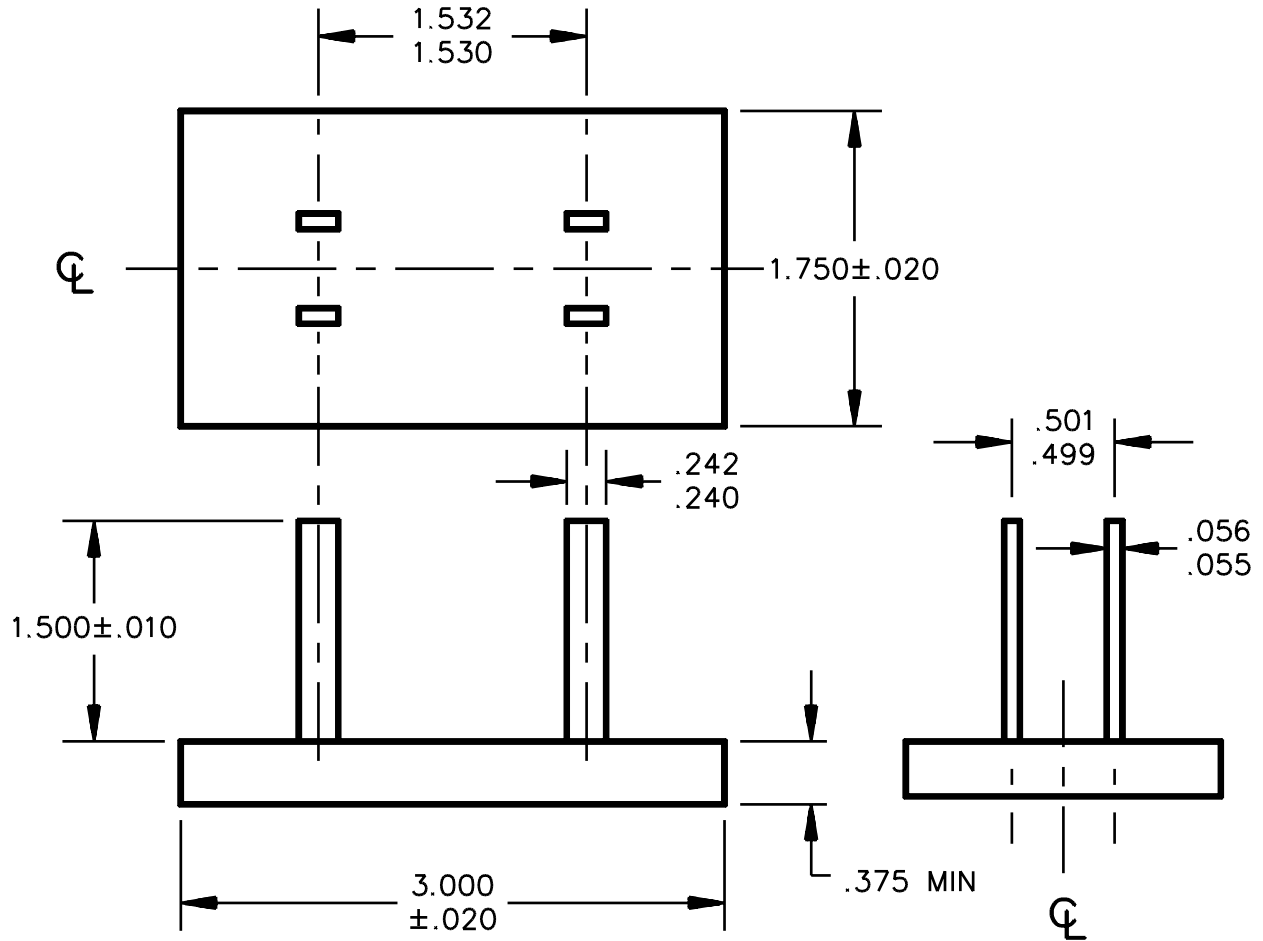

S3336

UL COPYRIGHTED MATERIAL –  
NOT AUTHORIZED FOR FURTHER REPRODUCTION OR  
DISTRIBUTION WITHOUT PERMISSION FROM UL

### 144.3 Method B

144.3.1 Six self-contained receptacles rated 15 A are to be installed on two conductor 14 AWG copper cable with ground and the cable subjected to a 50 lbf (222 N) applied perpendicular to the cable's entry into the device in a direction tending to separate the rear section from the front section. Six self-contained receptacles rated 20 A are to be similarly tested using two conductor 12 AWG copper cables with ground. The force is to be applied for one minute.

144.3.1 revised November 16, 2007

### 145 Field Replacement Test

145.1 A self-contained receptacle that is intended to be replaced in the field with a conventional outlet box and receptacle is to be installed on a typical wall panel of the minimum thickness intended in accordance with the manufacturer's instructions. The self-contained receptacle is then to be removed from the wall. A conventional outlet box and receptacle are then to be installed.

145.2 Installation of the conventional outlet box and receptacle shall be readily accomplished by using wall support tabs furnished with the box or "old work" brackets. The opening in the wall around the replacement outlet box shall be such that it is entirely covered when a standard-sized (not oversized) flush plate is installed.

### 146 Fault Current Withstand Test

146.1 After subjecting a self-contained receptacle to the Fault Current Withstand Test described in this section:

- a) There shall not be any damage to the cable that could render it incapable of being used in the installation of a similar self-contained replacement-type receptacle or a conventional outlet box and receptacle; and
- b) The circuit breaker shall operate in each case.

146.2 Typical installations of the self-contained receptacle are to be made in the intended manner, using the maximum and minimum cables (conductor sizes). Each installed device is to be connected using 4 feet (1.22 mm) of the maximum size wire to a 60 Hz power supply capable of delivering 1000 A at 120 V when the system is short-circuited at the test terminals. The test circuit is to have a thermal-type or an inverse-time molded-case type circuit breaker connected in one ungrounded line between the test terminals and the receptacle. The breaker rating should correspond to the rating of the wire used in the test. Each of three devices is to be tested by applying the test current to the device by inserting into a device opening an attachment plug whose terminals are connected using a short length of conductor. This procedure is then to be repeated on the same devices using a 200 A, 120 V circuit.



## 147 Knockouts Test

147.1 Knockouts provided on a self-contained receptacle shall remain intact when subjected to a 10 lbf (44.5 N) for one minute applied perpendicular to the plane of the knockout. The force is to be applied, by means of a mandrel with a 1/4 inch (6.4 mm) diameter flat end, at the point considered most likely to displace the knockout.

147.2 Knockouts shall be readily removable without breakage of the insulating body of the enclosure or sharp edges becoming present. Knockouts shall be displaced by means of a screwdriver or by using other conventional tools.

## 148 Creep Test

148.1 A self-contained receptacle shall be capable of withstanding the Cable Pullout Test described in Section 140 following the oven conditioning described in 148.2.

148.2 Self-contained receptacles employing thermoplastic material are to be assembled as a splice installation onto nonmetallic sheathed cable of the maximum AWG size conductor intended for use. Each device is then to be conditioned in an air-circulating oven for 300 hours at 90°C (194°F).

## 149 Mold Stress Test

149.1 Following the aging conditioning described in 149.2 and once the device has cooled to room temperature, a self-contained receptacle shall not exhibit:

- a) A change in any overall dimension greater than 10 percent; or
- b) An opening larger than 1/32 inch (0.8 mm) at any joint.

149.2 The self-contained receptacles employing thermoplastic material, unassembled and without cable installed, are to be conditioned in a circulating-air oven for a period of 7 hours at 90°C (194°F). Upon cooling to room temperature, the joint openings are to be measured after installation on cable as intended.

## 150 Specimen Flammability Test

### 150.1 General

150.1.1 Insulating materials employed in a self-contained receptacle are to be subjected to this test. A total of fifteen specimens for each material is to be tested as follows:

- a) Five in the as-received state using method A,
- b) Five following seven days of conditioning in an air oven at  $90.0 \pm 1.0^\circ\text{C}$  ( $194.0 \pm 1.8^\circ\text{F}$ ) using Method A, and
- c) Five in the as-received state using Method B.

*Exception No. 1: Molded phenolic or urea formaldehyde insulating material is not required to be subjected to this test.*

*Exception No. 2: An insulating material having a minimum V-2 is not required to be subjected to this test. See 40.1 (b)(1).*

**UL COPYRIGHTED MATERIAL –  
NOT AUTHORIZED FOR FURTHER REPRODUCTION OR  
DISTRIBUTION WITHOUT PERMISSION FROM UL**

## 150.2 Method A

150.2.1 When tested as described for V-2 material in the Standard for Tests for Flammability of Plastic Materials for Parts in Devices and Appliances, UL 94, each 5.0 by 0.50 inch (127 by 12.7 mm) specimen shall:

- a) Not burn with flaming combustion for more than 30 seconds after each withdrawal of the test flame.
- b) Not burn with flaming or glowing combustion up to the holding clamp, and
- c) Not burn with glowing ember for more than 50 seconds after the second withdrawal of the test flame.

## 150.3 Method B

150.3.1 When tested as described for HB material in the Standard for Tests for Flammability of Plastic Materials for Parts in Devices and Appliances, UL 94, each 5.0 by 0.50 inch (127 by 12.7 mm) specimen shall cease to burn before the flame reaches the reference mark located 4.0 inches (102 mm) from its free end.

## CURRENT TAPS

All Devices

### 151 General

151.1 The performance of a current tap wired to flexible cord is to be investigated by means of the tests described in Sections 55 – 103 and Section 152 as specified in Table 54.6.

### 152 Contact Security Test

152.1 The female contacts of a current tap having a 1-15R configuration shall remain inaccessible to contact after the current tap has been tested as described in this section.

152.2 The current tap is to be rigidly supported in the blades-up position. The current tap is to be positioned and supported so as not to restrict possible displacement of the female contacts, breakage of the enclosure, or both. Each blade, in turn, is to be individually subjected to a force of 30 lbf (133 N) applied gradually along the longitudinal axis of the blade in a direction towards the plug face. The 30 lbf (133 N) is to be maintained for a period of 1 minute.

152.3 The same devices are to be retested as described in 152.2 subjecting both blades, in combination, to a single applied force of 40 lbf (178 N) for a period of 1 minute.

**UL COPYRIGHTED MATERIAL –  
NOT AUTHORIZED FOR FURTHER REPRODUCTION OR  
DISTRIBUTION WITHOUT PERMISSION FROM UL**

## FLATIRON AND APPLIANCE PLUGS

### 153 General

153.1 The performance of a flatiron or appliance plug is to be evaluated by means of the tests described in Sections 55 – 64 and Sections 154 – 161 as specified in Table 54.7 on sets of six representative devices.

153.2 A switching mechanism in a flatiron or appliance plug shall comply with the requirements in the Standard for General-Use Snap Switches, UL 20. The devices for the snap-switch tests are to be devices that have not been subjected to any other tests.

### 154 Millivolt Drop Test

154.1 In a previously untested switchless flatiron or appliance plug, the drop in potential between a wiring terminal and the corresponding male pin shall not be greater than 50 mV while maximum rated current is flowing. This requirement applies also to a plug that incorporates a switching mechanism, except that the millivolt drop applies only to the female contacts.

154.2 To determine whether a flatiron or appliance plug complies with the requirement in 154.1, the plug is to be wired in the intended manner and connected to any convenient d-c potential. The load connections for the plug are to consist of a pair of standard stainless-steel male pins mounted on a sheet of insulating material and provided with terminals to which an adjustable noninductive load can be connected. The dimensions and spacings of pins are provided in Table 50.1. With the plug applied to the pins as it would be in service and with maximum rated current flowing through the circuit, the drop in potential is to be measured between each wiring terminal of the plug (use the line side of each female contact in a plug with a switching mechanism) and the corresponding terminal on each male pin.

### 155 Overload Test

155.1 A flatiron or appliance plug shall perform acceptably when operated manually at a rate not greater than 6 cycles per minute for 50 cycles of making and breaking a direct current of 150 percent of the 250 V current rating for the plug. The device shall remain capable of functioning as intended and there shall not be any undue pitting or burning of the contacts.

155.2 Devices which have been subjected to the millivolt-drop test are to be tested as described in this section.

155.3 A pair of pins intended for use with the plug being tested is to be mounted on an insulating support and connected to a noninductive resistive load that will draw the required test current at the rated voltage.

155.4 Each plug is to be wired with heater cord, connected to a nominal 250 V d-c supply (238 to 262 V), and then successively applied and withdrawn from the pins as it would be in service until the 50 cycles have been completed. Neither the plug nor the pins are to be serviced in any manner during the test. The plug is to be withdrawn each time by the application of a steady pull on the cord.

### 156 Heating Test

156.1 The insulating material used in a flatiron or appliance plug shall be capable of withstanding a temperature of 200°C (392°F) for a period of 72 hours without warping, cracking, blistering, softening, or showing any other indication of serious deterioration.

156.2 Devices which have been subjected previously to the millivolt-drop and overload tests are to be subjected to air at the specified temperature. The test devices may be heated in any oven, the temperature of which can be regulated and measured properly. The oven is to be brought up to the required temperature before the devices are positioned within on their contact ends.

### 157 Millivolt Drop Test Repeated

157.1 The millivolt-drop test is to be repeated following the heating test on flatiron or appliance plugs that have been subjected previously to the millivolt-drop, overload, and heating tests. The potential drop between a wiring terminal and the corresponding male pin shall not be greater than 100 mV. See also 154.1 and 154.2.

### 158 Crushing Test

158.1 An appliance plug rated 5 A at 250 V and 10 A at 125 V shall be capable of withstanding a crushing force of 125 lbf (556 N) for 1 minute as described in this Section without cracking or breaking. Other plugs shall be capable of withstanding a force of 150 lbf (667 N) similarly applied.

158.2 Plugs are to be employed that have not been previously subjected to any of the tests in Sections 154 – 157. Each untested plug is to be laid flat on a 1/2 inch (12.7 mm) or thicker horizontal maple block. The force is to be applied by means of a horizontal 3/4 inch diameter (19.1 mm) round rod. The force is to be transmitted to the rod by means of the weight and lever of a testing machine. The force is to be applied gradually. The rod is to be aligned at right angles to the major axis of the plug, midway between the points at which the plug contacts the supporting surface.

### 159 Mechanical Endurance Test

159.1 After a flatiron or appliance plug that is rated 5 A at 250 V and 10 A at 125 V, and that has been oven conditioned at 200°C (392°F) for 24 hours, is dropped by machine in the manner described in this section, it shall not:

- a) Crack or break to the extent that it becomes unfit for use or exposes live parts to unintentional contact, or
- b) Experience any displacement of current-carrying parts or loosening of the cord at the wiring terminals.

159.2 If an unacceptable result occurs that is attributable directly to a broken switch handle or a release button, the test may be repeated to determine whether the handle or button will break on nonoven-conditioned devices. If the handle or button does not break, and none of the causes for rejection given in 159.1 occur, the mechanical endurance of the plug is acceptable.

159.3 Previously untested devices are to be used. Three plugs that include a switch are to be tested with the switch in the off position. The three remaining devices are to be tested with the switch in the on position.

159.4 Although the details of the machinery to accomplish the impacts are not specified, the test is to be conducted as follows. Each plug is to be wired with 18 AWG (0.82 mm<sup>2</sup>) Type HPD cord, the free end of which is to be passed through and knotted behind a bushing located at the point labeled A in Figure 159.1. The cord is to be free to rotate in the bushing. Initially, the cord and plug are to hang freely and rest in the position labeled 1 in Figure 159.1 against the vertical face of the block C, which is a 1-1/2 – 2 inch thick (38.1 – 50.8 mm) piece of maple that is high and wide enough so that a plug will not strike near one of the edges of the block. The grain is to run vertically. The plane of the face of block C is to contain point A. The distance from the bushing to the contact end of the plug is to be 45 inches (1.14 m). Lifting member B of the machine is to lift the plug by the cord to the position labeled 2 in Figure 159.1. At this point the edge of member B furthest from point A is to be 38 inches (0.97 m) from the plane of the face of block C on a line perpendicular to the plane at point A. The cord is to be released from member B and the plug is to fall freely to strike block C. The machine is to repeat the operation continuously for the required number of cycles. Screws employed to hold plug halves together are to be replaced and tightened whenever they fall out. Generally, screws that have been tightened every 200 cycles will not loosen sufficiently to fall out.

159.4 revised November 16, 2007

**UL COPYRIGHTED MATERIAL –  
NOT AUTHORIZED FOR FURTHER REPRODUCTION OR  
DISTRIBUTION WITHOUT PERMISSION FROM UL**

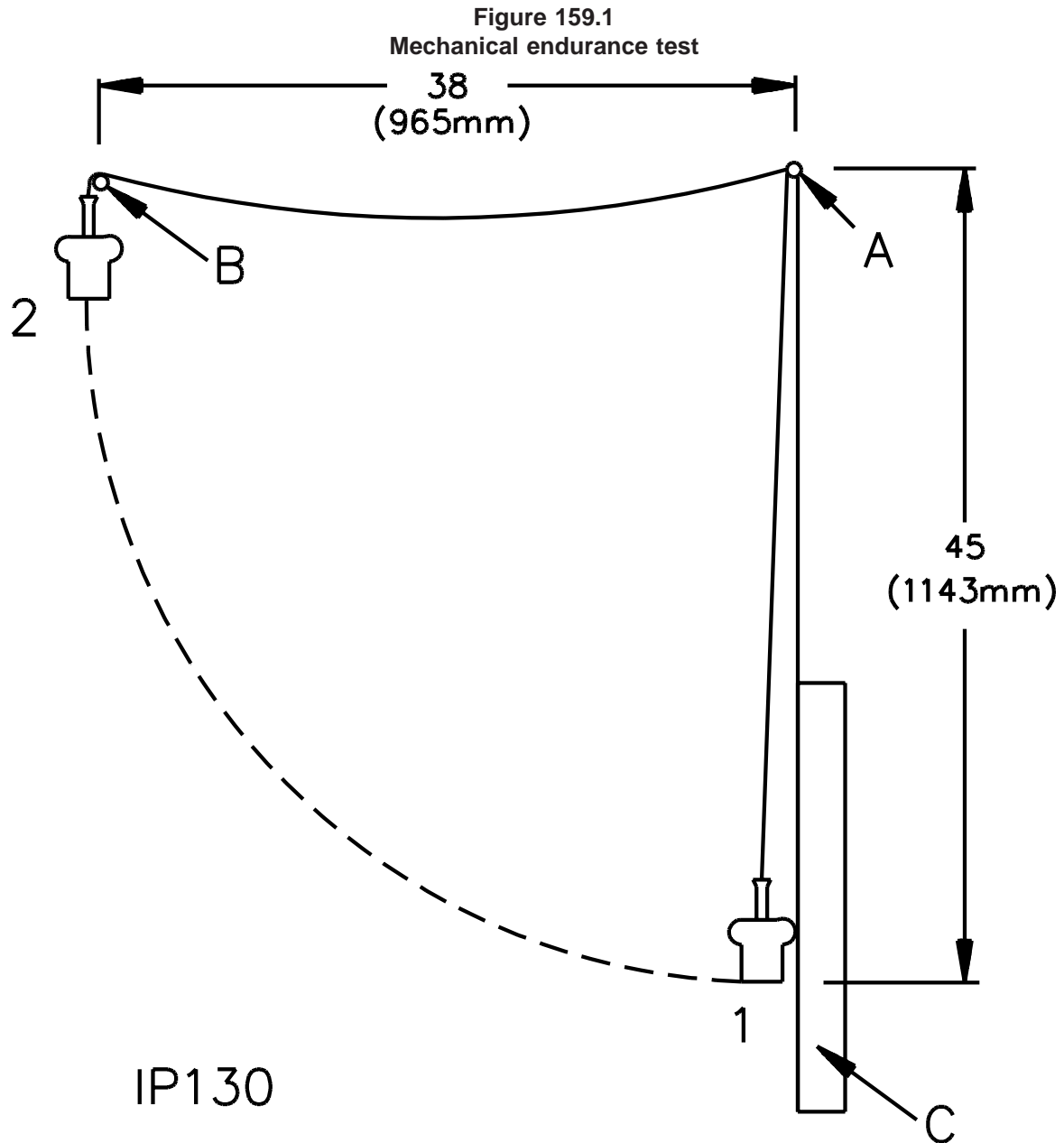

## NOTES

A – Supporting bushing

B – Lifting Member

C – Maple block

1 and 2 – See 159.4

**UL COPYRIGHTED MATERIAL –  
NOT AUTHORIZED FOR FURTHER REPRODUCTION OR  
DISTRIBUTION WITHOUT PERMISSION FROM UL**

159.5 A switchless plug is acceptable if the average number of drops without damage is not less than 1000 for the six devices tested without any of the devices determined to be unacceptable within the first 500 drops. In computing the average, 1300 drops is to be used for any device which performs acceptably for more than 1300 drops.

159.6 A plug incorporating a switch is acceptable if the average number of drops without damage is not less than 500 for the six devices tested without any of the devices determined to be unacceptable within the first 250 drops. In computing the average, 650 drops is to be used for any device which performs acceptably for more than 650 drops.

### 160 Accelerated Aging Test

160.1 If a rubber guard is employed in a flatiron or appliance plug, the rubber compound shall not show any visible deterioration after being subjected to accelerated aging in which the guard is maintained at a temperature of  $120.0 \pm 1.0^{\circ}\text{C}$  ( $248.0 \pm 1.8^{\circ}\text{F}$ ) in an oven for a period of 96 hours. Following the oven conditioning, the guard shall not show any cracks after being subjected to 5000 cycles of flexing by a machine as described in this section.

160.2 The guard is to be assembled to the body of the plug, and the assembly wired in the intended manner with a 2 – 3 ft (0.61 – 0.91 m) length of heater cord. With the plug held stationary, the guard is to be flexed by moving the cord back and forth in a plane through an angle of approximately 180 degrees.

### 161 Cord Guard Test

161.1 To determine if a guard complies with the requirement in 48.3 it is to be tested with a 3 lb (1.36 kg) weight similar to a plumb bob attached to a short length of heater cord that is wired to the plug in the intended manner. The flatiron or appliance plug is to be mounted rigidly in a horizontal position as indicated in part A of Figure 161.1. Dimension X is to be measured with the axis of the cord and guard coincidental with the axis of the plug with no force being applied to the cord. The weight is to bend the guard as indicated in part B of Figure 161.1 under which conditions dimension Y is to be less than 60 percent of dimension X and dimension Z is to be not less than 5/8 inch (15.9 mm).

*Exception: A guard is not required to comply with this requirement if, upon investigation, it is found to provide protection equivalent to that provided by a guard that does comply. See also 48.3.*

Figure 161.1  
Test of cord guard

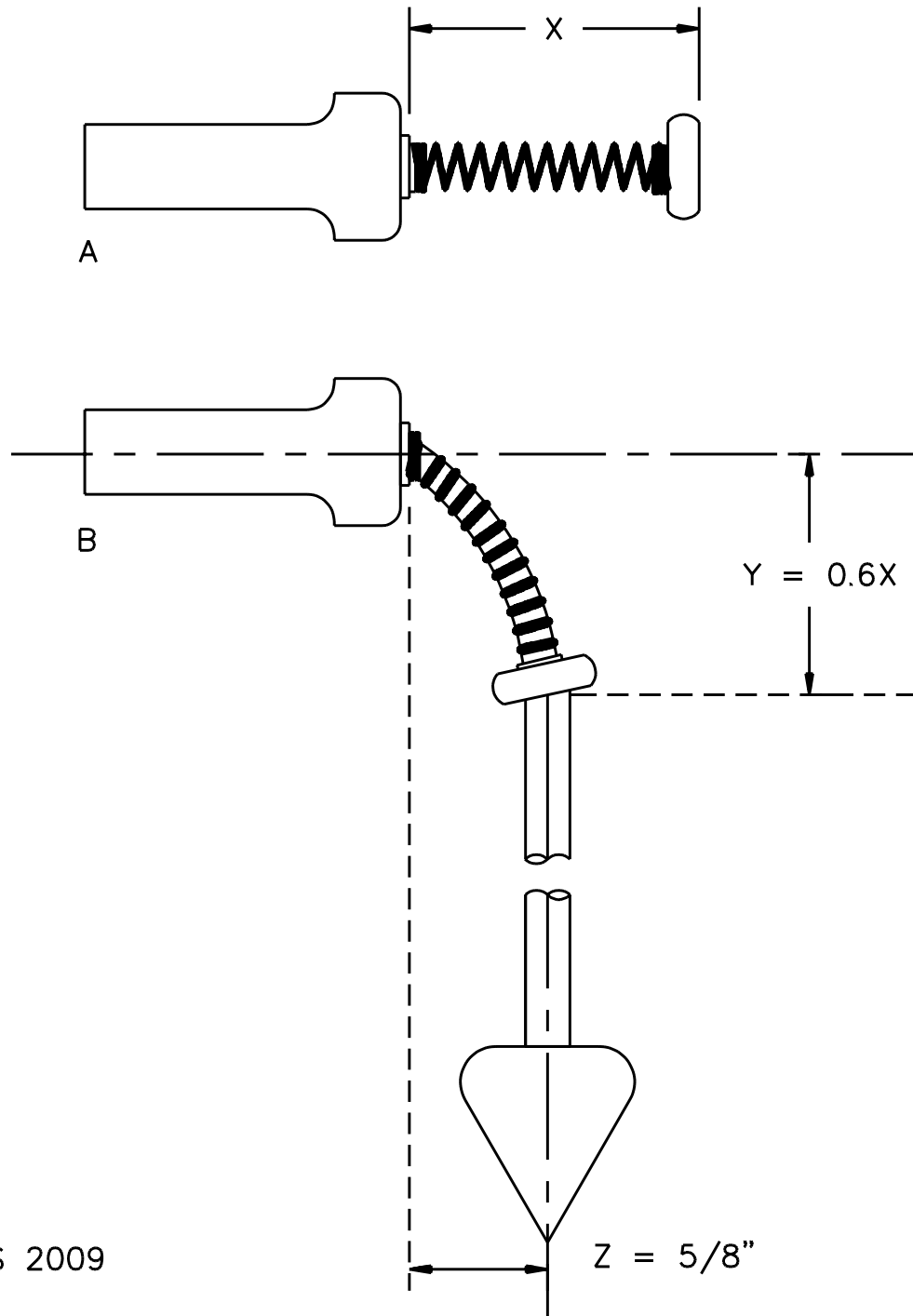

S 2009

inch  
mm

5/8  
15.9

UL COPYRIGHTED MATERIAL –  
NOT AUTHORIZED FOR FURTHER REPRODUCTION OR  
DISTRIBUTION WITHOUT PERMISSION FROM UL



## RATINGS

### 162 Details

162.1 A general-use device shall be rated in amperes and volts. When the contact configuration of the device is one of the configurations illustrated in Wiring Devices – Dimensional Specifications, ANSI/NEMA WD6, or in the Standard for Wiring Device Configurations, UL 1681, the device shall be given only the rating shown in the configuration. Otherwise, the device shall be given one or more of the ratings in Table 162.1. See 6.1, 162.4, and 162.5.

*Exception No. 1: Plugs, cord connectors, and current taps for use on flexible cords, or that are provided with fuses, are permitted to have a lower current rating than that shown in the configuration.*

*Exception No. 2: A device that is a combination of special-use devices as described in 162.2 is not required to comply with this requirement.*

**Table 162.1**  
**Ratings of general-use devices**

Ratings
10A, 250V and 15 A, 125V
15 A, 125 V
15 A, 250 V
15 A, 277 V ac
20 A, 125 V
20 A, 250 V
20 A, 277 V ac
30 A, 250 V
50 A, 250 V
60 A, 250 V
75 A, 250 V
75 A, 480 V ac
75 A, 600 V ac
75 A, 600 V
100 A, 250 V
100 A, 480 V ac
100 A, 600 V ac
100 A, 600 V
200 A, 250 V
200 A, 480 V ac
200 A, 600 V ac
200 A, 600 V

**UL COPYRIGHTED MATERIAL –  
NOT AUTHORIZED FOR FURTHER REPRODUCTION OR  
DISTRIBUTION WITHOUT PERMISSION FROM UL**

162.2 A special-purpose receptacle or cord connector may be rated in accordance with test performance results and the anticipated conditions of end use, and may be rated in horsepower in addition to the required ampere rating.

162.3 A flush receptacle or attachment plug of a configuration specified in Table 162.2 shall have a horsepower rating in accordance with the table. A cord connector, appliance, equipment or fixture outlet, surface-mount receptacle, or current tap of a configuration specified in Table 162.2 and assigned a horsepower rating shall be rated in accordance with the table. See 88.1.1, 88.3.1 – 88.3.3 and 111.1.1, 111.3.1 – 111.3.3.

**Table 162.2**  
**Horsepower ratings for NEMA configurations**

NEMA configuration	AC HP rating <sup>a</sup>
1-15	0.5
2-15	1.5
2-20	2
2-30	2
5-15	0.5
5-20	1
5-30	2
5-50	2
6-15	1.5
6-20	2
6-30	2
6-50	3
7-15	2
7-20	2
7-30	3
7-50	5
10-20	2 L-L 1 L-N
10-30	2 L-L 2 L-N
10-50	3 L-L 2 L-N
11-15	2
11-20	3
11-30	3
11-50	7.5
14-15	1.5 L-L 0.5 L-N
14-20	2 L-L 1 L-N

**UL COPYRIGHTED MATERIAL –  
NOT AUTHORIZED FOR FURTHER REPRODUCTION OR  
DISTRIBUTION WITHOUT PERMISSION FROM UL**

Table 162.2 Continued on Next Page

Table 162.2 Continued

NEMA configuration	AC HP rating <sup>a</sup>
14-30	2 L-L 2 L-N
14-50	3 L-L 2 L-N
14-60	3 L-L 2 L-N
15-15	2
15-20	3
15-30	3
15-50	7.5
15-60	10
18-15	2
18-20	2
18-30	3
18-50	7.5
18-60	7.5
L1-15	0.5
L2-20	2
L5-15	0.5
L5-20	1
L5-30	2
L6-15	1.5
L6-20	2
L6-30	2
L7-15	2
L7-20	2
L7-30	3
L8-20	3
L8-30	5
L10-20	2 L-L 1 L-N
L10-30	2 L-L 2 L-N
L11-15	2
L11-20	3
L11-30	3
L12-20	5
L12-30	10

UL COPYRIGHTED MATERIAL –  
NOT AUTHORIZED FOR FURTHER REPRODUCTION OR  
DISTRIBUTION WITHOUT PERMISSION FROM UL

Table 162.2 Continued on Next Page

Table 162.2 Continued

NEMA configuration	AC HP rating <sup>a</sup>
L14-20	2 L-L 1 L-N
L 14-30	2 L-L 2 L-N
L15-20	3
L15-30	3
L16-20	5
L16-30	10
L 18-20	2
L18-30	3
L19-20	5
L19-30	10
L21-20	2
L21-30	3
L22-20	5
L22-30	10

<sup>a</sup> The phase to phase horsepower ratings are noted by "L-L". The phase to neutral ratings are identified by "L-N".

162.4 If a device includes a snap switch that controls an outlet, the overall rating of the device shall not be higher than the rating of the switch.

162.5 If a two-wire device includes a pilot-lamp lampholder of the candelabra- or miniature-base size, the overall rating of the device shall not be more than 125 V.

162.6 A device shall be rated for disconnecting use only, not for current rupturing, if the potential rating is higher than 250 V dc. A device may be rated for disconnecting use only, not for current rupturing, if the current rating is greater than 60 A ac, dc, or ac-dc. See 88.1.1 and 111.1.1.

162.7 An appliance or flatiron plug shall be rated 5 A at 250 V and 10 A at 125 V if the spacing between centers of the contacts is 11/16 inch (17.5 mm) or less. However, if the spacing between centers of the contacts is more than 11/16 inch (17.5 mm), an appliance plug shall be rated 10 A at 250 V and 15 A at 125 V. See 6.1.

**UL COPYRIGHTED MATERIAL –  
NOT AUTHORIZED FOR FURTHER REPRODUCTION OR  
DISTRIBUTION WITHOUT PERMISSION FROM UL**

## MARKINGS AND INSTRUCTIONS

### 163 General

#### 163.1 Details

163.1.1 All markings and instructions required by this section shall be legibly and permanently marked and readily visible in the specified location.

163.1.2 A marking shall be die stamped, ink stamped, painted, molded, or otherwise applied in a manner determined to be indelible in accordance with the Standard for Marking and Labeling Systems, UL 969. Other contrasting methods providing equivalent prominence and permanence meet the intent of the requirement.

163.1.3 An attachment plug shall be provided with all applicable markings and instructions described in Table 163.1.

163.1.4 An inlet shall be provided with all applicable markings and instructions described in Table 163.2.

163.1.5 A cord connector shall be provided with all applicable markings and instructions described in Table 163.3.

163.1.6 A receptacle shall be provided with all applicable markings and instructions described in Table 163.4.

163.1.7 A current tap intended for use on flexible cord shall be provided with all applicable markings and instructions described in Table 163.5.

163.1.8 A flatiron or appliance plug shall be provided with all applicable markings and instructions described in Table 163.6.

163.1.9 An angle or shroud adapter for use with attachment plugs and cord connectors shall be provided with all applicable markings and instructions described in Table 163.7.

#### 163.2 Location of markings and instructions

163.2.1 A marking or instruction that is required to be provided on a device without any other restriction shall appear on any surface of the device that will be visible after the device is completely assembled but not installed in the intended manner.

163.2.2 A marking or instruction that is required to be provided on a device where visible during installation shall appear on any surface of the device that will be visible to the installer while wiring and assembling the device in the intended manner.

163.2.3 A marking or instruction that is required to be provided on a device where visible during use shall appear on any surface of the device that will be visible after the device is completely assembled and installed in the intended manner, but not on a face or other surface that will be obscured when the device is mated with another.

163.2.4 A marking or instruction that is required to be provided on a device where visible after installation shall appear on any surface of the device that will be visible after the device is completely assembled and installed in the intended manner. On a receptacle, such a marking shall appear in one of the following locations:

- a) On the front of the body or mounting yoke of a receptacle intended for use with a separate flush plate;
- b) On the outside of a receptacle mounted on a metal outlet-box cover; or
- c) On the inside of the insulating cover or on the exposed side of the base of a receptacle having an integral flush plate or outlet-box cover of insulating material.

The marking is not to appear on plaster ears, whether the ears are separate pieces or are integral with the mounting means, unless the marking also appears elsewhere on the device.

163.2.5 The installation instructions for 5-15R, 5-20R, 6-15R and 6-20R flush receptacles as specified in Table 163.4 shall be located as follows:

- a) Individually packaged devices intended for field installation – On the device, the unit container, or on an instruction sheet or card packaged within the unit container. The instructions may be provided on a separate single instruction sheet or card enclosed in a unit container containing more than two receptacles if the container is marked "Individual devices not marked for retail sale" or equivalent wording.

A display card which serves as the unit container and that is used to provide the required instructions for individually packaged receptacles shall be attached to the receptacle in such a fashion that it cannot be accidentally removed or torn free from the receptacle during shipment, distribution or normal handling. The use of a blister package or an equivalent means of securing the card to the receptacle is acceptable. Friction alone is not an acceptable method of attaching the card to the receptacle.

- b) Bulk-shipped devices intended for field installation – On each device or provided in the bulk shipping container. One set of instructions shall be provided for each device. The instructions may be bundled in bulk, provided on a tear-off pad, or in other form that is packed in the bulk shipping container. The instructions need not be attached to each individual receptacle.
- c) Bulk-shipped devices intended for factory installation as a component of other equipment – On the device, the unit container, or on a separate single instruction sheet or card enclosed in the shipping container. The shipping container shall be marked with a statement, "See enclosed installation instructions" or equivalent wording.

163.2.6 If any of the instructions described in 163.2.5 are placed on the unit container or display card or on an information sheet packed in the unit container, then all such information in its entirety shall be so placed. The information in a marking or instruction shall not be divided between a unit container and an information sheet. A portion of the information may be repeated in more than one location.

**UL COPYRIGHTED MATERIAL –  
NOT AUTHORIZED FOR FURTHER REPRODUCTION OR  
DISTRIBUTION WITHOUT PERMISSION FROM UL**

**Table 163.1**  
**Markings and instructions applicable to attachment plugs**

Description	Reference	Marking	Location
All plugs	1	<p>a) The manufacturer's name, trade name or trademark, or other descriptive marking by which the organization responsible for the device is to be identified. A traceable code is not prohibited when the device is identified by the brand or trademark owned by a private labeler.</p> <p>b) The catalog number or an equivalent designation.</p> <p>c) The electrical rating in amps and volts. A device rated for use on alternating current circuits only shall be identified by one of the following means:</p> <ol style="list-style-type: none"> <li>1) The letters "AC",</li> <li>2) The words "AC Only",</li> <li>3) The symbol "<math>\sim</math>",</li> <li>4) A frequency marking (for example, "60 Hertz"),</li> <li>5) A phase marking such as "<math>\Phi</math>", the letters "ph" or "PH", or the word "phase". For multiphase devices that are intended for use only on a wye system, the marking shall also include the word "wye", or the letter "Y".</li> </ol> <p><i>Exception No. 1: A fuseless attachment plug having a 1-15P or 5-15P configuration is not required to be marked with its electrical rating.</i></p> <p><i>Exception No. 2: An attachment plug of a configuration specified in Table 162.2 is not required to be marked with its horsepower rating.</i></p>	<p>On the device where visible after installation</p> <p><i>Exception: The catalog number is not prohibited from appearing on the unit container when the product is too small, or where the legibility is difficult to attain, or where several catalog numbers use common parts</i></p>
Plugs produced at more than one factory	2	A distinctive marking, not prohibited from being in code, identifying the device as the product of a particular factory.	On device
Plugs requiring strip length information. See 9.1.3.	3	Strip length information for the intended conductors.	On the device near the wiring terminals, or on a separate instruction sheet provided.

Table 163.1 Continued

Description	Reference	Marking	Location
Plugs intended for field wiring	4	<p>a) The intended flexible-cord types (such as Type S, SJ, SJT, HPN, and SPT-1). A cord identification referring to the generic (trade) names for each family of cords (such as Hard Service Cord, Vacuum Cleaner Cord, and Parallel Cord) is not prohibited when all types of cords identified in the family can be utilized with the device.</p> <p>b) The conductor size or sizes.</p> <p>c) The total number of conductors.</p> <p>d) The overall cord diameter range, if the device is intended to be utilized with a limited range of the cord diameters available for a cord type. The information is not prohibited from being combined in an abbreviated format (such as wire sizes 18/3 SV to 14/3 SJ, 0.230 – 0.450 inch diameter). The conductor sizes, total number of conductors and overall diameters shall be included individually or as a range with the appropriate cord types.</p>	On the device, on the smallest unit container, or on a stuffer sheet provided with each device



Table 163.1 Continued

Description	Reference	Marking	Location
Plugs with pin-type terminals for field assembly on flexible cord	5	<p>a) Instructions for assembling the device to the cord. Details shall be provided, including pictorial representation, to enable proper assembly by an inexperienced person.</p> <p>b) The words "CAUTION - Risk of electric shock. Do not strip wires. Cut off end of cord cleanly." or an equivalent wording following the word CAUTION and any other specific instructions concerning cord preparation.</p> <p>c) Instructions concerning the cord type or types to be used. A description shall be provided of any type of cord that may not be physically excluded but which is not intended to be used (for example, not for use with Type TPT extra-flexible cord such as used on electric shavers). There are some cord groups that are not distinguishable by marking and, where one of these cords is recommended, all shall be capable of proper use or be physically excluded.</p> <p>d) If the device is polarized, the words "CAUTION - Risk of electric shock. Proper polarization must be maintained. Examine the cord carefully before assembling this product. If one of the wires is marked with stripes, grooves or ridges on the outer surface of the insulation, attach that wire to the white-colored terminal. If neither wire is marked, strip a small amount of insulation from the end of both wires and check to see whether either of the wires is white in color. If so, the white wire should be connected to the white-colored terminal. After identifying the white wire, cut end of cord cleanly before attaching the wires to the terminals." or an equivalent wording following the word CAUTION.</p> <p>e) Electrical rating in volts, amperes and wattage corresponding to the ampacity of the cord. If more than one size or type of cord is intended to be used, the electrical rating shall be indicated for each type cord.</p>	On an instruction card attached to the device in such a manner that the device is unable to be readily removed. The use of a blister pack or equivalent securing of the device to the instruction card meets the intent of the requirement. However, the friction attachment of a device to the card shall not be employed.
Plugs with nongrounding configurations (other than 1-15, 1-20, 1-30, 2-15, 2-20, 2-30)	6	"CAUTION: This device is not for grounding use. Connect only to nongrounding circuits."	On the device where visible during installation, on the smallest unit container, or on a stuffer sheet provided with each device
Plugs with locking configurations	7	"Turn and pull" or an equivalent wording.	On the device where visible during use
Plugs with Fig. C3.8 configuration	8	"Hospital only." See Exception to 15.3.6.	On the device where visible after installation.
Plugs with Fig. C3.9, C3.10, C3.11 and C3.12 configurations	9	"CAUTION: To Avoid Electric Shock - Review premises carefully and do not use if this slot or blade configuration (design) is already in a circuit having a rating differing from the rating of this device."	On the device where visible during installation, on the smallest unit container, or on a stuffer sheet provided with each device

UL COPYRIGHTED MATERIAL –  
 NOT AUTHORIZED FOR FURTHER REPRODUCTION OR  
 DISTRIBUTION WITHOUT PERMISSION FROM UL

Table 163.1 Continued on Next Page

Table 163.1 Continued

Description	Reference	Marking	Location
Armored plugs with grounded covers	10	<p>“Cover grounded” or with an equivalent statement.</p> <p><i>Exception No. 1: The marking is not required if the grounding connection is readily visible.</i></p> <p><i>Exception No. 2: The marking is not required for an attachment plug of the type described in 11.6.</i></p>	On the device
Plugs with fuses (other than plug or cartridge type for branch circuit protection)	11	“Use only with a ___ volt fuse.” The potential to be used in the marking shall be the potential rating of the fuse for which the device is intended.	On the device where visible during fuse replacement
Plugs with fuses where the fuse can be removed after the plug has been inserted in receptacle. See the Exception to 15.4.6.	12	“Disconnect power before replacing fuses” or an equivalent wording.	On the device where visible during fuse replacement

**UL COPYRIGHTED MATERIAL –  
NOT AUTHORIZED FOR FURTHER REPRODUCTION OR  
DISTRIBUTION WITHOUT PERMISSION FROM UL**

**Table 163.2**  
**Markings and instructions applicable to inlets (motor attachment plugs)**

Description	Reference	Marking	Location
All inlets	1	<p>a) The manufacturer's name, trade name or trademark, or other descriptive marking by which the organization responsible for the device is to be identified. A traceable code is not prohibited when the device is identified by the brand or trademark owned by a private labeler.</p> <p>b) The catalog number or an equivalent designation.</p> <p>c) The electrical rating. A device rated for use on alternating current circuits only shall be identified by one of the following means:</p> <ol style="list-style-type: none"> <li>1) The letters "AC",</li> <li>2) The words "AC Only",</li> <li>3) The symbol "<math>\sim</math>",</li> <li>4) A frequency marking (for example, "60 Hertz"),</li> <li>5) A phase marking such as "<math>\Phi</math>", the letters "ph" or "PH", or the word "phase". For multiphase devices that are intended for use only on a wye system, the marking shall also include the word "wye", or the letter "Y".</li> </ol> <p><i>Exception: An inlet of a configuration specified in Table 162.2 is not required to be marked with its horsepower rating.</i></p>	<p>On the device where visible after installation</p> <p><i>Exception: The catalog number is not prohibited from appearing on the unit container when the product is too small, or where the legibility is difficult to attain, or where several catalog numbers use common parts</i></p>
Inlets produced at more than one factory	2	A distinctive marking, not prohibited from being in code, by which the device can be identified as the product of a particular factory.	On the device
Inlets with non conductive mounting means. See 19.1 and 19.4	3	"CAUTION - Mounting means not grounded. Grounding wire connection required" or an equivalent wording following the word CAUTION.	On the device where visible during installation
Inlets with pressure-wiring terminals for field wiring on a branch circuit	4	The value of tightening torque assigned in accordance with 12.4.3.	On the device where visible during installation, on the smallest unit container, or on an information sheet packed in the smallest unit container
Inlets with nongrounding configurations (other than 1-15, 1-20, 1-30, 2-15, 2-20, 2-30)	5	"CAUTION: This device is not for grounding use. Connect only to nongrounding circuits."	On the device where visible during installation, on the smallest unit container, or on a stuffer sheet provided with each device

**UL COPYRIGHTED MATERIAL –  
NOT AUTHORIZED FOR FURTHER REPRODUCTION OR  
DISTRIBUTION WITHOUT PERMISSION FROM UL**

Table 163.2 Continued on Next Page

Table 163.2 Continued

Description	Reference	Marking	Location
Inlets with Figure C3.8 Configuration	6	"Hospital only." See Exception to 15.3.6.	On the device where visible after installation
Inlets with Fig. C3.9, C3.10, C3.11, and C3.12 configurations	7	"CAUTION: To Avoid Electric Shock - Review premises carefully and do not use if this slot or blade configuration (design) is already in a circuit having a rating differing from the rating of this device."	On the device where visible during installation, on the smallest unit container, or on a stuffer sheet provided with each device
Inlets with fuses (other than plug or cartridge type for branch circuit protection)	8	"Use only with a ___ volt fuse." The potential to be used in the marking shall be the potential rating of the fuse for which the device is intended.	On the device where visible during fuse replacement

**Table 163.3**  
**Marking and instructions applicable to cord connectors**

Description	Reference	Marking	Location
All cord connectors	1	<p>a) The manufacturer's name, trade name or trademark, or other descriptive marking by which the organization responsible for the device is to be identified. A traceable code is not prohibited when the device is identified by the brand or trademark owned by a private labeler.</p> <p>b) The catalog number or an equivalent designation.</p> <p>c) The electrical rating. A device rated for use on alternating current circuits only shall be identified by one of the following means:</p> <ol style="list-style-type: none"> <li>1) The letters "AC",</li> <li>2) The words "AC Only",</li> <li>3) The symbol "<math>\sim</math>",</li> <li>4) A frequency marking (for example,</li> <li>5) A phase marking such as "<math>\Phi</math>", the letters "ph" or "PH", or the word "phase". For multiphase devices that are intended for use only on a wye system, the marking shall also include the word "wye", or the letter "Y".</li> </ol>	<p>On the device where visible after installation</p> <p><i>Exception: The catalog number is not prohibited from appearing on the unit container when the product is too small, or where the legibility is difficult to attain, or where several catalog numbers use common parts.</i></p>
Cord connectors produced at more than one factory	2	A distinctive marking, not prohibited from being in code, by which the device can be identified as the product of a particular factory.	On the device
Cord connectors intended for disconnecting use only	3	"For disconnecting use only," or "Not for current rupturing," or an equivalent statement.	On the device where visible during use

Table 163.3 Continued

Description	Reference	Marking	Location
Cord connectors requiring strip length information. See 9.1.3	4	Strip length information for the intended conductors.	On the device near the wiring terminals or on a separate instruction sheet provided with each device.
Cord connections intended for field wiring	5	<p>a) The intended flexible-cord types (such as type S, SJ, SJT, HPN, and SPT-1). A cord identification referring to the generic (trade) names for each family of cords (such as Hard Service Cord, Vacuum Cleaner Cord, and Parallel Cord) is not prohibited when all types of cords identified in the family can be utilized with the device.</p> <p>b) The conductor size or sizes.</p> <p>c) The total number of conductors.</p> <p>d) The overall cord diameter range, if the device is intended to be utilized with a limited range of the cord diameters available for a cord type. The information is not prohibited from being combined in an abbreviated format (such as wire sizes 18/3 SV to 14/3 SJ, 0.230 – 0.450 inch diameter). The conductor sizes, total number of conductors and overall diameters shall be included individually or as a range with the appropriate cord types.</p>	On the device, on the smallest unit container, or on a stuffer sheet provided with each device

Table 163.3 Continued

Description	Reference	Marking	Location
Cord connectors with pin-type terminals for field assembly on flexible cord	6	<p>a) Instructions for assembling the device to the cord. Details shall be provided, including pictorial representation, to enable proper assembly by an inexperienced person.</p> <p>b) The words "CAUTION – Risk of electric shock. Do not strip wires. Cut off end of cord cleanly." or an equivalent wording following the word CAUTION and any other specific instructions concerning cord preparation.</p> <p>c) Instructions concerning the cord type or types to be used. A description shall be provided of any type of cord that may not be physically excluded but which is not intended to be used (for example, not for use with Type TPT extra-flexible cord such as used on electric shavers). There are some cord groups that are not distinguishable by marking and, where one of these cords is recommended, all shall be capable of proper use or be physically excluded.</p> <p>d) If the device is polarized, the words "CAUTION – Risk of electric shock. Proper polarization must be maintained. Examine the cord carefully before assembling this product. If one of the wires is marked with stripes, grooves or ridges on the outer surface of the insulation, attach that wire to the white-colored terminal. If neither wire is marked, strip a small amount of insulation from the end of both wires and check to see whether either of the wires is white in color. If so, the white wire should be connected to the white-colored terminal. After identifying the white wire, cut end of cord cleanly before attaching the wires to the terminals." or an equivalent wording following the word CAUTION.</p> <p>e) Electrical rating in volts, amperes and wattage corresponding to the ampacity of the cord. If more than one size or type of cord is intended to be used, the electrical rating shall be indicated for each type cord.</p>	On an instruction card attached to the device in such a manner that the device is unable to be readily removed. The use of a blister pack or equivalent securing of the device to the instruction card meets the intent of the requirement. However, the friction attachment of a device to the card shall not be employed.
Cord connectors with nongrounding configurations (1-15, 1-20, 1-30, 2-15, 2-20, 2-30)	7	"CAUTION: This device is not for grounding use. Connect only to nongrounding circuits."	On the device where visible during installation, on the smallest unit container, or on a stuffer sheet provided with each device
Cord connectors with locking configurations	8	"Turn and pull" or an equivalent wording.	On the device where visible during use.
Cord connectors with Fig. C3.8 configuration	9	"Hospital only." See Exception to 15.3.6.	On the device where visible after installation
Cord connectors with Fig. C3.9, C3.10, C3.11 and C3.12 configurations	10	"CAUTION: To Avoid Electric Shock - Review premises carefully and do not use if this slot or blade configuration (design) is already in a circuit having a rating differing from the rating of this device."	On the device where visible during installation, on the smallest unit container, or on a stuffer sheet provided with each device

UL COPYRIGHTED MATERIAL –  
 NOT AUTHORIZED FOR FURTHER REPRODUCTION OR  
 DISTRIBUTION WITHOUT PERMISSION FROM UL

Table 163.3 Continued on Next Page

Table 163.3 Continued

Description	Reference	Marking	Location
Armored cord connectors with grounded covers	11	<p>"Cover grounded" or an equivalent statement.</p> <p><i>Exception No. 1: The marking is not required if the grounding connection is readily visible.</i></p> <p><i>Exception No. 2: The marking is not required for a cord connector of the type described in 11.6.</i></p>	On the device
Cord connectors with spring-actuated latching mechanism	12	A statement instructing the user how to disengage the latching mechanism so that a mated attachment plug can be removed from the cord connector outlet.	On the device where visible during use

**Table 163.4**  
**Marking and instructions applicable to receptacles**

Table 163.4 revised November 16, 2007

Description	Reference	Marking	Location
All receptacles	1	<p>a) The manufacturer's name, trade name or trademark, or other descriptive marking by which the organization responsible for the device is to be identified. A traceable code is not prohibited when the device is identified by the brand or trademark owned by a private labeler.</p> <p>b) The catalog number or an equivalent designation.</p> <p>c) The electrical rating. A device rated for use on alternating current circuits only shall be identified by one of the following means:</p> <ol style="list-style-type: none"> <li>1) The letters "AC",</li> <li>2) The words "AC Only",</li> <li>3) The symbol "<math>\sim</math>",</li> <li>4) A frequency marking (for example, "60 Hertz"),</li> <li>5) A phase marking such as "<math>\Phi</math>", the letters "ph" or "PH", or the word "phase". For multiphase devices that are intended for use only on a wye system, the marking shall also include the word "wye", or the letter "<math>\gamma</math>".</li> </ol> <p><i>Exception: A receptacle of a configuration specified in Table 162.2 is not required to be marked with its horsepower rating</i></p>	<p>On the device where visible after installation. See 163.2.4 for location details.</p> <p><i>Exception No. 1: The catalog number is not prohibited from appearing on the unit container when the product is too small, or where the legibility is difficult to attain, or where several catalog numbers use common parts.</i></p> <p><i>Exception No. 2: The installation instructions for 5-15R, 5-20R, 6-15R, and 6-20R flush receptacles shall be located as specified in 163.2.5. See also Reference No. 23 in this table.</i></p>

UL COPYRIGHTED MATERIAL –  
 NOT AUTHORIZED FOR FURTHER REPRODUCTION OR  
 DISTRIBUTION WITHOUT PERMISSION FROM UL

Table 163.4 Continued on Next Page

Table 163.4 Continued

Description	Reference	Marking	Location
Receptacles produced at more than one factory	2	A distinctive marking, not prohibited from being in code, by which the device can be identified as the product of a particular factory.	On the device
Receptacles requiring strip length information. See 9.1.3	3	Strip length information for the intended conductors.	On the device near the wiring terminals, or on a separate instruction sheet provided with each device.
Receptacles not intended for interrupting current	4	"CAUTION – Risk of Electric Shock. Do Not Disconnect Under Load" or an equivalent statement following the word "CAUTION".	On the device where visible while the device is in the mated condition
Receptacles with fuses (other than plug or cartridge type for branch circuit protection)	5	"Use only with a ___ volt fuse." The potential to be used in the marking shall be the potential rating of the fuse for which the device is intended.	On the device where visible during fuse replacement
Receptacles with TT-R configuration	6	"Recreational Vehicle use only"	On the device where visible after installation
Receptacles with Fig. C3.8 configuration	7	A grounding, locking-type receptacle with the configuration shown in Figure C3.8 for use in hospitals only shall be marked "Hospital only." See Exception to 15.3.6.	On the device where visible after installation
Receptacles with nonconductive mounting means. See 29.1.2.	8	"CAUTION - Mounting means not grounded. Grounding wire connection required" or an equivalent wording following the word CAUTION.	On the device where visible during installation
Isolated-ground receptacles	9	An orange colored triangle with sides 5/32 inch (4.0 mm) or more in length. The triangle is not required to be a contrasting shade of orange if the face of the receptacle is orange colored.	On the device where visible after the receptacle and cover plate are installed
		"Isolated Ground" and "CAUTION - Mounting means not grounded. Grounding wire connection required," or with an equivalent wording following the word "CAUTION."	On the device where visible during installation
		A statement indicating its intended use to reduce electrical noise (electromagnetic interference) by purposely insulating the grounding circuit from any metallic wiring system.	On the device, on the smallest unit container, or on a stuffer sheet provided with each device.
Display receptacles	10	"Display Receptacle" or equivalent wording. The words "Floor Receptacle" are not considered to be equivalent.	On the device where visible during installation
Receptacles with push-in terminals	11	a) Instructions for releasing the wire from the terminal connection, that shall be located where readily visible during wiring and rewiring, b) "Solid wire only" unless the terminal is intended for both solid and stranded wire, c) Instructions to strip the insulation from conductors a specific length where readily visible during installation, d) Instructions for connecting properly sized wire where readily visible during installation.	On the device where visible during installation
CO/ALR receptacles	12	"CO/ALR"	On the device where visible after installation
		"Replace Only With CO/ALR Device".	On the device where visible during installation

UL COPYRIGHTED MATERIAL –  
NOT AUTHORIZED FOR FURTHER REPRODUCTION OR  
DISTRIBUTION WITHOUT PERMISSION FROM UL

Table 163.4 Continued on Next Page



Table 163.4 Continued

Description	Reference	Marking	Location
AL-CU devices	13	A receptacle rated 30 A or greater which is intended for use with aluminum conductors or copper and aluminum conductors shall be marked "AL-CU".	On the device where visible after installation

No Text on This Page

Document Was Downloaded By jianxiong chen For Use By KAI HUA (FOSHAN SHUNDE) ELECTRIC APPLIANCE CO LTD 22381 : 5/8/2008 - 10:34 AM

***UL COPYRIGHTED MATERIAL –  
NOT AUTHORIZED FOR FURTHER REPRODUCTION OR  
DISTRIBUTION WITHOUT PERMISSION FROM UL***

Table 163.4 Continued

Description	Reference	Marking	Location
AL-CU receptacles for use on 75°C wire	14	A receptacle rated 30 A or greater which is intended for use with aluminum conductors or copper and aluminum conductors rated 75 °C (167 °F) shall be marked "AL-CU, 75 °C".	On the device where visible after installation
Tamper-resistant receptacles	15	The phrase "Tamper Resistant" or the letters "TR". The letters "TR" shall be a minimum of 3/16 inch (4.8 mm) in height.	On the device where visible after installation with the cover plate removed
Self-contained receptacles	16	Installation instructions that include the following: a) Manufacturer's name and complete address b) Catalog number or its equivalent. c) Intended conductor material, cable type, and cable size. d) Limitations for use - for example, "mobile homes". e) Necessary installation instructions such as:  1) Wall or ceiling limitations (material, thickness),  2) Cable preparation (required slack, tools),  3) Selection of wiring material,  4) Bracket references, and  5) Maximum 2.125- inch (54- mm) slit length for nonmetallic sheathed cable being prepared for installation.	On the smallest unit package, tag or stuffer sheet provided with each device.
		A device not capable of being replaced with a conventional outlet box and receptacle shall be marked with: a) The type of receptacle necessary for replacement purposes, and b) Instructions for disassembly prior to replacement.	On the device where visible after installation
		A device intended for replacement with similar devices without the use of special tools shall be specifically marked to indicate this.	On the device where visible after installation
Receptacles with pressure-wiring terminals for field wiring on branch circuits	17	The value of tightening torque assigned in accordance with 12.4.3.	On the device where visible during installation, on the smallest unit container, or on an information sheet packed in the smallest unit container.
Receptacles with nongrounding configurations (other than 1-15, 1-20, 1-30, 2-15, 2-20, 2-30)	18	"CAUTION: This device is not for grounding use. Connect only to nongrounding circuits."	On the device where visible during installation, on the smallest unit container, or on a stuffer sheet provided with each device.

UL COPYRIGHTED MATERIAL –  
NOT AUTHORIZED FOR FURTHER REPRODUCTION OR  
DISTRIBUTION WITHOUT PERMISSION FROM UL

Table 163.4 Continued on Next Page

Table 163.4 Continued

Description	Reference	Marking	Location
Receptacles with Fig. C3.9, C3.10, C3.11, C3.12 configurations	19	"CAUTION: To Avoid Electric Shock - Review premises carefully and do not use if this slot or blade configuration (design) is already in a circuit having a rating differing from the rating of this device."	On the device where visible during installation, on the smallest unit container, or on a stuffer sheet provided with each device.
Flush receptacles with 1-15R configuration	20	"REPLACEMENT USE ONLY ON EXISTING CIRCUITS WITH NO MEANS FOR GROUNDING," or the equivalent.	On the smallest unit container
15 and 20 A flush receptacles with wire-binding screws, back-wired pressure plates (clamp terminals), and/or push-in terminals for use with copper wire only	21	<p>a) "Notice - Use only copper or copper-clad wire with this device",</p> <p>b) "Notice - Connect only copper or copper-clad wire to this device", or</p> <p>c) "Notice - Use only devices marked CO/ALR with aluminum wire".</p> <p><i>Exception: When the device itself carries the marking, one of the following abbreviated markings or the symbol shown in Figure 163.1 meets the intent of the requirement.</i></p> <p>a) "Use copper wire only",</p> <p>b) "Cu wire only",</p> <p>c) "Use copper or copper-clad wire only", or</p> <p>d) "Cu and Cu-clad wire only".</p> <p>The marking on the device shall be legible with letters at least 1/16 inch (1.6 mm) high.</p> <p>When molded, the circles and bar of the marking described in Figure 163.1 shall be formed by lines that have twice the width and thickness of the lines used for the letters "CU" and "AL" within the circles.</p>	On the device, on a stuffer sheet, or on the smallest unit container for individually packaged devices; on the device for devices packed for bulk shipment
All 5-15R, 5-20R, 6-15R and 6-20 R flush and self-contained receptacles	22	Date or other dating period of manufacture not exceeding any three consecutive months. An abbreviated date of manufacture or a nationally accepted conventional code or code affirmed by the manufacturer is not prohibited provided that the code does not repeat in less than 20 years, and does not require reference to the production records of the manufacturer to determine when the receptacle was manufactured.	On the device

Table 163.4 Continued

Description	Reference	Marking	Location
All 5-15R, 5-20R, 6-15R and 6-20 R flush receptacles	23	<p>Installation instructions that contain all of the information needed for installation and use as intended, including the following:</p> <p>a) The manufacturer's name or trademark.</p> <p>b) The words "To Install", "Installation Instructions", or the equivalent.</p> <p>c) Branch circuit conductor wire size for each terminal construction provided on the receptacle. A reference to sizing the branch circuit conductors in accordance with the National Electrical Code meets the intent of the requirement when the instructions also contain a cautionary marking restricting installation to a qualified person. This information is not required for a receptacle employing wire leads.</p> <p>d) Branch circuit conductor strip length. A strip gauge marked on the device meets the intent of the requirement; however, when the installation instructions are provided on a separate sheet or container, the instructions shall either reproduce or make specific reference to the strip gauge marked on the device. This information is not required for a receptacle employing wire leads.</p> <p>e) Wire lead strip length, when the receptacle is provided with wire leads. This information is not required when the wire leads are pre-stripped.</p> <p>f) Directions for attaching the line, grounded (neutral) and grounding conductors to the appropriate terminals or leads of the receptacle. The words "White Wire", "Black Wire", "Bare or Green Wire", "Equipment Grounding Conductor", or equivalent identifiers or abbreviations marked adjacent to the appropriate terminals on the device or on a wiring diagram meet the intent of the requirement.</p>	See 163.2.5 and 163.2.6
5-15R, 5-20R, 6-15R and 6-20 R flush receptacles with only push-in terminals	24	"15 ampere branch circuits only" and "14 AWG solid copper conductors only", or equivalent wording.	On the device where visible during installation
		"For use on 15 ampere branch circuits only and with 14 AWG solid copper conductors only", or equivalent wording.	On the smallest unit container
	25	Installation instructions which include a reference to the maximum 15 A branch circuit overcurrent protector rating and limitation to 14 AWG solid copper branch circuit conductors for a receptacle employing push-in terminals.	See 163.2.5 and 163.2.6
5-15R, 5-20R, 6-15R and 6-20R flush receptacles with combination push-in and wire-binding screw terminals	26	"Push-in terminals for use on 15 ampere branch circuits only and with 14 AWG solid copper conductors only" or equivalent wording.	On the device where visible during installation
		"Push-in terminals for use on 15 ampere branch circuits only and with 14 AWG solid copper conductor only. Do not use push-in terminals on a 20 ampere branch circuit."	On the smallest unit container

UL COPYRIGHTED MATERIAL –  
NOT AUTHORIZED FOR FURTHER REPRODUCTION OR  
DISTRIBUTION WITHOUT PERMISSION FROM UL

Table 163.4 Continued on Next Page

Table 163.4 Continued

Description	Reference	Marking	Location
5-15R, 5-20R, 6-15R and 6-20R flush receptacles with combination push-in and wire-binding screw terminals	27	Installation instructions which include a reference to the maximum 15 A branch circuit overcurrent protector rating and limitation to 14 AWG solid copper branch circuit conductors for a receptacle employing push-in terminals.	See 163.2.5 and 163.2.6
5-15R, 5-20R, 6-15R, and 6-20R flush receptacles with push-in terminals with a wire release mechanism	28	Installation instructions which include instructions regarding reuse or rewiring for a receptacle employing push-in terminals with a wire-release mechanism.	See 163.2.5 and 163.2.6
5-15R, 5-20R, 6-15R, and 6-20R flush receptacles with push-in terminals without a wire release mechanism	29	"Push-in terminals not for reuse", or with an equivalent wording, where visible during installation.	On the device where visible during installation
	30	Installation instructions which include the phrase "Do not re-use or rewire push-in terminals" or equivalent wording for a receptacle employing push-in terminals that are not provided with a wire release mechanism.	See 163.1.5 and 163.1.6.

**Table 163.5**  
**Markings and instructions applicable to current taps wired on flexible cord**

Description	Reference	Marking	Location
All current taps	1	<p>a) The manufacturer's name, trade name or trademark, or other descriptive marking by which the organization responsible for the device is to be identified. A traceable code is not prohibited when the device is identified by the brand or trademark owned by a private labeler.</p> <p>b) The catalog number or an equivalent designation.</p> <p>c) The electrical rating. A device rated for use on alternating current circuits only shall be identified by one of the following means:</p> <ol style="list-style-type: none"> <li>1) The letters "AC",</li> <li>2) The words "AC Only",</li> <li>3) The symbol "<math>\sim</math>",</li> <li>4) A frequency marking (for example, "60 Hertz"),</li> <li>5) A phase marking such as "<math>\Phi</math>", the letters "ph" or "PH", or the word "phase". For multiphase devices that are intended for use only on a wye system, the marking shall also include the word "wye", or the letter "Y".</li> </ol>	<p>On the device where visible after installation</p> <p><i>Exception: The catalog number is not prohibited from appearing on the unit container when the product is too small, or where the legibility is difficult to attain, or where several catalog numbers use common parts</i></p>

UL COPYRIGHTED MATERIAL –  
 NOT AUTHORIZED FOR FURTHER REPRODUCTION OR  
 DISTRIBUTION WITHOUT PERMISSION FROM UL

Table 163.5 Continued on Next Page

Table 163.5 Continued

Description	Reference	Marking	Location
Current taps produced at more than one factory	2	A distinctive marking, not prohibited from being in code, by which the device can be identified as the product of a particular factory.	On the device
Current taps requiring strip information. See 9.1.3	3	Strip length information for the intended conductors.	a) On the device near the wiring terminals, or b) On a separate instruction sheet provided with each device.
Current taps intended for field wiring	4	<p>a) The intended flexible-cord types (such as type S, SJ, SJT, HPN, and SPT-1). A cord identification referring to the generic (trade) names for each family of cords (such as Hard Service Cord, Vacuum Cleaner Cord, and Parallel Cord) is not prohibited when all types of cords identified in the family can be utilized with the device.</p> <p>b) The conductor size or sizes</p> <p>c) The total number of conductors.</p> <p>d) The overall cord diameter range, if the device is intended to be utilized with a limited range of the cord diameters available for a cord type.</p> <p>The information is not prohibited from being combined in an abbreviated format (such as wire sizes 18/3 SV to 14/3 SJ, 0.230 – 0.450 inch diameter). The conductor sizes, total number of conductors and overall diameters shall be included individually or as a range with the appropriate cord types.</p>	On the device, on the smallest unit container, or on a stuffer sheet provided with each device.

Table 163.5 Continued

Description	Reference	Marking	Location
Current taps with pin-type terminals intended for field assembly on flexible cord	5	<p>a) Instructions for assembling the device to the cord. Details shall be provided, including pictorial representation, to enable proper assembly by an inexperienced person.</p> <p>b) The words "CAUTION – Risk of electric shock. Do not strip wires. Cut off end of cord cleanly." or an equivalent wording following the word CAUTION and any other specific instructions concerning cord preparation.</p> <p>c) Instructions concerning the cord type or types to be used. A description shall be provided of any type of cord that may not be physically excluded but which is not intended to be used (for example, not for use with Type TPT extra-flexible cord such as used on electric shavers). There are some cord groups that are not distinguishable by marking and, where one of these cords is recommended, all shall be capable of proper use or be physically excluded.</p> <p>d) If the device is polarized, the words "CAUTION – Risk of electric shock. Proper polarization must be maintained. Examine the cord carefully before assembling this product. If one of the wires is marked with stripes, grooves or ridges on the outer surface of the insulation, attach that wire to the white-colored terminal. If neither wire is marked, strip a small amount of insulation from the end of both wires and check to see whether either of the wires is white in color. If so, the white wire should be connected to the white-colored terminal. After identifying the white wire, cut end of cord cleanly before attaching the wires to the terminals." or an equivalent wording following the word CAUTION.</p> <p>e) Electrical rating in volts, amperes and wattage corresponding to the ampacity of the cord. If more than one size or type of cord is intended to be used, the electrical rating shall be indicated for each type cord.</p>	On an instruction card attached to the device in such a manner that the device is unable to be readily removed. The use of a blister pack or equivalent securing of the device to the instruction card meets the intent of the requirement. However, the friction attachment of a device to the card shall not be employed.
Current taps for disconnecting use only	6	"For disconnecting use only," or "Not for current rupturing," or an equivalent statement.	On the device
Current taps with fuses (other than plug or cartridge type for branch circuit protection)	7	"Use only with a ___ volt fuse." The potential to be used in the marking shall be the potential rating of the fuse for which the device is intended.	On the device where visible during fuse replacement
Current taps with fuses where the fuse can be removed after the blades have been inserted in receptacle. See the Exception to 15.4.6.	8	"Disconnect power before replacing fuses" or an equivalent wording.	On the device where visible during fuse replacement

**UL COPYRIGHTED MATERIAL –  
NOT AUTHORIZED FOR FURTHER REPRODUCTION OR  
DISTRIBUTION WITHOUT PERMISSION FROM UL**



**Table 163.6**  
**Marking and instructions applicable to flatiron and appliance plugs**

Description	Reference	Marking	Location
All flatiron and appliance plugs	1	<p>a) The manufacturer's name, trade name or trademark, or other descriptive marking by which the organization responsible for the device is to be identified. A traceable code is not prohibited when the device is identified by the brand or trademark owned by a private labeler.</p> <p>b) The catalog number or an equivalent designation.</p> <p>c) The electrical rating. A device rated for use on alternating current circuits only shall be identified by one of the following means:</p> <ol style="list-style-type: none"> <li>1) The letters "AC",</li> <li>2) The words "AC Only",</li> <li>3) The symbol "<math>\sim</math>",</li> <li>4) A frequency marking (for example, "60 Hertz"),</li> <li>5) A phase marking such as "<math>\Phi</math>", the letters "ph" or "PH", or the word "phase". For multiphase devices that are intended for use only on a wye system, the marking shall also include the word "wye", or the letter "Y".</li> </ol>	<p>On the device where visible after installation.</p> <p><i>Exception: The catalog number is not prohibited from appearing on the unit container when the product is too small, or where the legibility is difficult to attain, or where several catalog numbers use common parts.</i></p>
Flatiron and appliance plugs produced at more than one factory	2	A distinctive marking, not prohibited from being in code, by which the device can be identified as the product of a particular factory.	On the device.
Flatiron and appliance plugs intended for field wiring	3	<p>a) The intended flexible-cord types (such as type S, SJ, SJT, HPN, and SPT-1). A cord identification referring to the generic (trade) names for each family of cords (such as Hard Service Cord, Vacuum Cleaner Cord, and Parallel Cord) is not prohibited when all types of cords identified in the family can be utilized with the device.</p> <p>b) The conductor size or sizes.</p> <p>c) The total number of conductors.</p> <p>d) The overall cord diameter range, if the device is intended to be utilized with a limited range of the cord diameters available for a cord type. The information is not prohibited from being combined in an abbreviated format (such as wire sizes 18/3 SV to 14/3 SJ, 0.230 – 0.450 inch diameter). The conductor sizes, total number of conductors and overall diameters shall be included individually or as a range with the appropriate cord types.</p>	On the device, on the smallest unit container, or on a stuffer sheet provided with each device.

**Table 163.7**  
**Marking and instructions applicable to angle and shroud adapters for use with attachment plugs and cord connectors**

Description	Reference	Marking	Location
All devices	1	<p>a) Identification of the attachment plugs, cord connectors, or both, on which the angle or shroud adapter is intended to be installed, identified by manufacturer name, catalog, or series designation.</p> <p>b) The intended flexible-cord types (such as type S, SJ, SJT, HPN, and SPT-1). A cord identification referring to the generic (trade) names for each family of cords (such as Hard Service Cord, Vacuum Cleaner Cord, and Parallel Cord) is not prohibited when all types of cords identified in the family can be utilized with the device.</p> <p>c) The conductor size or sizes.</p> <p>d) The total number of conductors.</p> <p>e) The overall cord diameter range, if the device is intended to be utilized with a limited range of the cord diameters available for a cord type. The information in b) through e) is not prohibited from being combined in an abbreviated format (such as wire sizes 18/3 SV to 14/3 SJ, 0.230 – 0.450 inch diameter). The conductor sizes, total number of conductors and overall diameters shall be included individually or as a range with the appropriate cord types.</p>	<p>a) On the device,</p> <p>b) On the smallest unit container, or</p> <p>c) On a stuffer sheet provided with each device</p>

**UL COPYRIGHTED MATERIAL –  
 NOT AUTHORIZED FOR FURTHER REPRODUCTION OR  
 DISTRIBUTION WITHOUT PERMISSION FROM UL**

Figure 163.1  
Non-CO/ALR marking

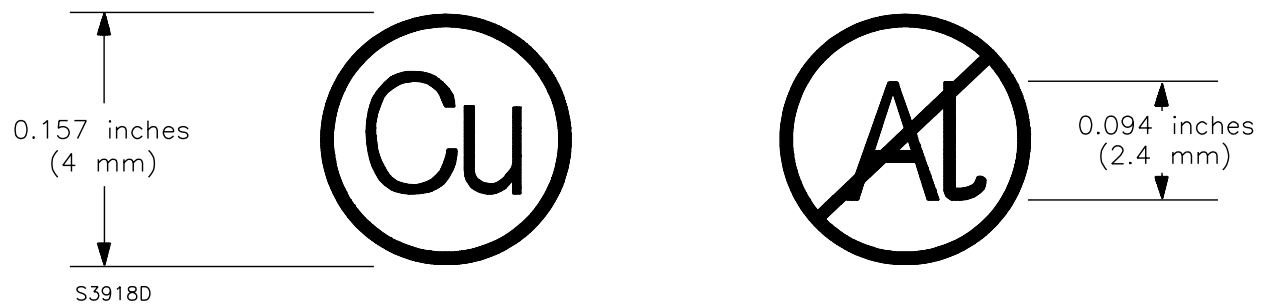

NOTE - Alternate methods of marking are not prohibited provided an equivalent prominence is achieved.

## 164 Identification and Marking of Terminals

### 164.1 Grounded and grounding

164.1.1 Device wiring terminals designated "W" (white) intended for connection to grounded circuit conductors or "G" (green) for grounding conductors shall be clearly and permanently identified on the device in accordance with Table 164.1 or 164.2. The colors or markings specified for this terminal identification shall not be applied to other than the designated terminals. The identifications shall be readily recognizable during wiring and relate directly to the appropriate terminals.

*Exception: A device that is intended only for factory assembly to a flexible cord and that is intended to be wired in accordance with Figure 164.1 is not required to comply with this requirement.*

UL COPYRIGHTED MATERIAL –  
NOT AUTHORIZED FOR FURTHER REPRODUCTION OR  
DISTRIBUTION WITHOUT PERMISSION FROM UL

## 164.2 Other terminals

164.2.1 Device wiring terminals other than the grounded and grounding terminals described in 164.1.1 are not required to be identified, but if they are, the letters "X", "Y", and "Z" shall be used for identification according to the following convention:

- a) Viewing the blade end of the plug and proceeding counter-clockwise starting from the grounding blade (G), or in the absence of a grounding blade, the grounded blade (W), the terminals shall be marked in sequence "X", "Y" and "Z."
- b) Viewing the face end of the receptacle and proceeding clockwise, starting from the grounding contact slot (G), or in the absence of a grounding contact slot, the grounded contact slot (W), the terminals shall be marked in sequence "X", "Y" and "Z."

**Table 164.1**  
**Identification of wiring terminals**

Table 164.1 revised November 16, 2007

Identification by:	Grounded terminal	Grounding terminal	All other terminals
Wire-binding screw	White metal or plating on circular screw head	Hexagonal, green-colored nut <sup>b</sup> or slotted screw head <sup>b</sup>	Other than white, grey, or green circular screw head
Pressure wire terminal-visible	White metal or plating on connector	Green-colored connector, screw or appendage <sup>b</sup>	Other than white, grey, or green colored terminal
Pressure wire terminal-concealed	Distinct white-colored area adjacent to wire entrance hole, or the word "white", or the letter "W" distinctively marked adjacent to wire entrance hole <sup>c</sup>	Distinct green-colored area adjacent to wire entrance hole, or the word "green" or "ground", the letters "G" or "GR" <sup>c</sup> , or the grounding symbol <sup>d</sup> distinctively marked adjacent to wire entrance hole	Other than white, grey, or green area adjacent to wire entrance hole (does not preclude a white, grey, or green back cover)
Terminal plate <sup>a</sup>	White metal or plating	–	Other than white, grey, or green metal or plating
Insulating enclosure or terminal	The word "white" or the letter "W", marked on or directly adjacent to terminal <sup>c</sup> , or white metal or plating on terminal	The word "green", or "ground", the letters "G" or "GR" <sup>c</sup> , or the grounding symbol <sup>d</sup> marked on or directly adjacent to terminal, or green colored terminal	Other than white, grey, or green-colored terminal
<sup>a</sup> Only when all line-terminal binding screws are of the same color. <sup>b</sup> Not readily removable. See 164.3.1. <sup>c</sup> In letters at least 1/16 inch (1.6 mm) high. <sup>d</sup> The grounding symbol shown in Figure 164.2 permitted with or without the circle.			

**Table 164.2**  
**Identification of leads**

Table 164.2 revised May 14, 2004

Identification by:	Grounded conductor	Grounding conductor	All other conductors
Color of braid <sup>b</sup>	Solid white or gray (without tracer)	Not applicable	White or gray with tracer in braid or Solid color other than white, gray, or green <sup>a</sup> (without tracer)
	Color other than white, gray or green, with tracer in braid	Not applicable	Solid color other than white, gray or green <sup>a</sup> (without tracer)
Color of insulation <sup>b</sup>	Solid white or gray; stripe, white or gray, on contrasting color other than green <sup>a</sup>	Green with or without one or more yellow stripes	Solid color other than white, gray, or green <sup>a</sup>
Color of separator <sup>b</sup>	Solid white or gray	Not applicable	Solid color other than white, gray or green <sup>a</sup>
Conductor tinning <sup>c</sup>	Tin or other acceptable metal on all strands of the conductor	Not applicable	No tin or other white metal on the strands of the conductor
<sup>a</sup> A green wire, with or without one or more yellow stripes, is to be used only as an equipment grounding conductor. <sup>b</sup> If color of braid, insulation, or separator is used for identification, all conductors are to be either tinned or not tinned. <sup>c</sup> If conductor tinning is used for identification, all braids and/or insulation are to have the same color and shape.			

**Figure 164.1**  
**Identifying cord or lead connections**

Figure 164.1 revised March 15, 2006

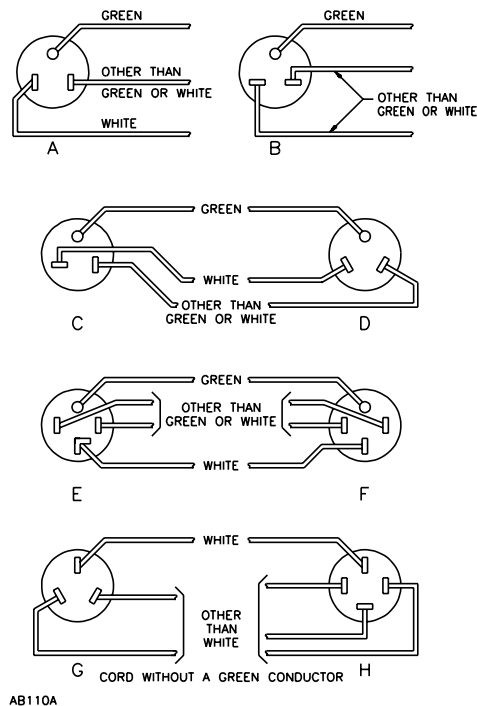

#### NOTES

A, C, and D – Only caps are illustrated. The white and other than green or white connections are interchanged on an outlet.

B and E-H – Each illustration is representative of an outlet or a cap.

A-F – One conductor is green.

G and H – No conductor is green.

A-F – The cross section of the blade to which the green conductor is connected may be U-shaped instead of circular as illustrated.

G – The cross section of the radial blade may be L-shaped instead of rectangular as illustrated.

A, C-F, G and H – White signifies that the conductor is finished to show a white or gray color or is equivalently identified by:

- 1) A white or gray separator,
- 2) A stripe, ridge, or groove on the outside surface of the insulation, or
- 3) A tin or other white metallic coating on each strand.

A-F – Green signifies that the insulation on the conductor is green with or without one or more yellow stripes.

F – This arrangement also covers three-pole, four-wire, 60-ampere, 125/250-volt devices if the white terminal is rotated 90 degrees.

**UL COPYRIGHTED MATERIAL –  
 NOT AUTHORIZED FOR FURTHER REPRODUCTION OR  
 DISTRIBUTION WITHOUT PERMISSION FROM UL**

Figure 164.2  
Grounding symbol

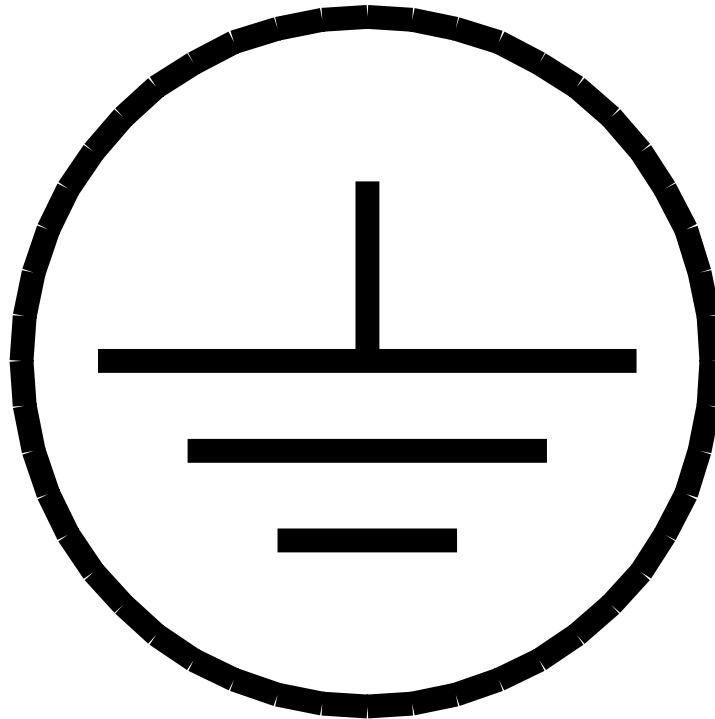

### 164.3 Removable parts

164.3.1 A part relied upon to provide the terminal identification required in 164.1.1 shall not be readily removable if it can be replaced with a similar part of another wiring terminal of the device. A suitably staked terminal screw is considered to be not readily removable for this purpose. A surface of a permanent appendage to a wiring terminal is not prohibited from being used to mark the terminal identification.

*Exception: A readily removable terminal intended for the equipment grounding conductor meets the intent of the requirement when the area adjacent to the terminal is also marked with one of the identifications specified in Table 164.1.*

164.3.2 Identification and marking of terminals in general-use devices other than those illustrated in Section C3 and in Wiring Devices – Dimensional Specifications, ANSI/NEMA WD6, may be accepted on a basis equivalent to that outlined in 164.1.1 – 164.3.1. See 15.3.1.

UL COPYRIGHTED MATERIAL –  
NOT AUTHORIZED FOR FURTHER REPRODUCTION OR  
DISTRIBUTION WITHOUT PERMISSION FROM UL

No Text on This Page

***UL COPYRIGHTED MATERIAL –  
NOT AUTHORIZED FOR FURTHER REPRODUCTION OR  
DISTRIBUTION WITHOUT PERMISSION FROM UL***



SUPPLEMENT SA - RESERVED FOR FUTURE USE

Document Was Downloaded By jianxiong chen For Use By KAI HUA (FOSHAN SHUNDE) ELECTRIC APPLIANCE CO LTD 22381 : 5/8/2008 - 10:34 AM

*UL COPYRIGHTED MATERIAL –  
NOT AUTHORIZED FOR FURTHER REPRODUCTION OR  
DISTRIBUTION WITHOUT PERMISSION FROM UL*

No Text on This Page

Document Was Downloaded By jianxiong chen For Use By KAI HUA (FOSHAN SHUNDE) ELECTRIC APPLIANCE CO LTD 22381 : 5/8/2008 - 10:34 AM

***UL COPYRIGHTED MATERIAL –  
NOT AUTHORIZED FOR FURTHER REPRODUCTION OR  
DISTRIBUTION WITHOUT PERMISSION FROM UL***

## SUPPLEMENT SB - ENCLOSURE TYPES FOR ENVIRONMENTAL PROTECTION

### INTRODUCTION

#### SB1 Scope

SB1.1 The requirements of this supplement cover an enclosure rating system for attachment plugs, receptacles, inlets, and cord connectors provided with an enclosure intended for use in various environmental applications.

SB1.2 A device with an environmental enclosure shall comply with the applicable requirements of this standard, UL 498, except as modified by the requirements in this supplement.

SB1.3 The requirements of this supplement do not cover enclosure type designations for wiring devices for use in hazardous locations as defined by the National Electrical Code, ANSI/NFPA 70.

#### SB2 Glossary

SB2.1 For the purposes of this supplement, the following definitions apply.

SB2.2 ENCLOSURE, ENVIRONMENTAL – That portion or those portions of a device intended to provide a degree of protection to the contacts, blades, terminals, and other live parts of that device and of any adjoining devices or components comprising a complete protective system against specified environmental conditions, both when the device is unmated and when it is fully connected to its intended mating device. This may include covers, gaskets, boots, and similar protective means. That portion or portions of a device providing such protection may differ for the unmated and the fully connected conditions.

SB2.3 GASKET – A deformable material clamped between stationary faces to provide a degree of protection as specified in Table SB6.1. This may include surfaces or features formed integrally from parts of the environmental enclosure made of deformable material.

SB2.4 SEALING MATERIAL – A pourable or extrudable substance, capable of some degree of hardening and bonding to substrates after application and used as a formed-in-place seal of joints or openings to reduce the likelihood of the passage of gases, vapors, or liquids.

**UL COPYRIGHTED MATERIAL –  
NOT AUTHORIZED FOR FURTHER REPRODUCTION OR  
DISTRIBUTION WITHOUT PERMISSION FROM UL**

## CONSTRUCTION

### SB3 General

SB3.1 When a receptacle or inlet is provided with or integrates into its design an outlet box, cabinet, junction box, or other portion of the environmental enclosure which includes a means for connection to a conduit, raceway, or other wiring system, in addition to the requirements in this supplement, such an outlet box, cabinet, junction box, or the like, shall comply with the applicable construction and performance requirements in the Standard for Metallic Outlet Boxes, UL 514A, the Standard for Nonmetallic Outlet Boxes, Flush-Device Boxes, and Covers, UL 514C, or the Standard for Enclosures for Electrical Equipment, UL 50, as appropriate.

SB3.2 When a receptacle or inlet is provided with or integrates into its design an outlet box cover or cover plate for flush devices, in addition to the requirements in this supplement, such a cover or cover plate shall comply with the applicable construction and performance requirements in the Standard for Metallic Outlet Boxes, UL 514A, the Standard for Nonmetallic Outlet Boxes, Flush-Device Boxes, and Covers, UL 514C, or the Standard for Cover Plates for Flush-Mounted Wiring Devices, UL 514D, as appropriate.

SB3.3 The enclosure of an attachment plug, receptacle, inlet, or cord connector marked with an enclosure type designation in accordance with SB7.1 shall comply with the construction requirements in the Standard for Enclosures for Electrical Equipment, UL 50, that correspond to the enclosure type. A device that complies with the requirements for more than one type of enclosure shall comply with the corresponding requirements for each enclosure type. The enclosure type designation for a device when unmated is not required to be the same as the enclosure type designation of that device when it is fully connected to its intended mating device.

SB3.4 All parts of an environmental enclosure shall be permanently secured to the wiring device such that they cannot be completely removed without the use of a tool after the device has been installed as intended.

*Exception: A part of an environmental enclosure can be completely removable without the use of a tool when the enclosure type designation required in SB7.1 is marked only on the removable part.*

SB3.5 A Type 2 or 3R enclosure shall have provisions for drainage.

*Exception No. 1: A device marked with a Type 2 or 3R enclosure rating that depends on an adjoining device or component comprising the complete environmental enclosure to provide drainage is not required to have provision for drainage on the device itself when the installation instructions or smallest unit container of a device identifies the intended adjoining device or component.*

*Exception No. 2: A Type 2 or 3R enclosure that is also marked as Type 12, 12K, or 13 shall be shipped with the provision for drainage blocked or closed. Instructions shall be provided with the device to indicate how to unblock or open the provision for drainage.*

SB3.6 For a receptacle or inlet marked with a Type 3, 3S, 4, 4X, 6, 6P, 12, 12K, or 13 enclosure rating, the mounting means shall be external to the cavity containing live parts.

SB3.7 A receptacle or inlet which is marked with a Type 12K enclosure rating and which includes conduit knockouts or reclosed openings for conductor entry shall have such knockouts or reclosed openings only in the top and bottom enclosure walls.

SB3.8 A Type 4, 4X, 6, or 6P environmental enclosure comprised of two mateable devices fully connected together shall have enclosure securement means other than blade-and-contact retention alone to resist unintended separation initiated solely by the force of hose-directed water.

SB3.9 To reduce the risk of unintentional separation while submerged, a Type 6 or 6P environmental enclosure comprised of two mateable devices fully connected together shall:

- a) Employ an enclosure securement means such that the devices cannot be disconnected without the use of a tool after the devices have been installed as intended, fully connected, and submerged, or
- b) Be marked on each device as indicated in SB7.7.

SB3.10 The Type 6 or 6P environmental enclosure designation shall be limited to grounding-type attachment plugs, receptacles, cord connectors, and inlets.

#### **SB4 Polymeric Enclosures**

SB4.1 Polymeric materials used for Types 3, 3R, 3S, 4 and 4X enclosures, or polymeric materials used for fastenings or hinges for these enclosure types shall comply with the Ultraviolet Light Exposure Test in the Standard for Polymeric Materials - Use in Electrical Equipment Evaluations, UL 746C.

*Exception No. 1: Compliance of elastomeric materials shall be demonstrated by the absence of any permanent damage such as distortion of the boot or fitting, or cracking or splitting of the material, following the exposure to ultraviolet light as described in UL 746C, and the subsequent impact test described in Section SB6.*

*Exception No. 2: A part fully internal to the environmental enclosure is not required to comply with this requirement.*

SB4.2 Polymeric materials used for Types 6 and 6P enclosures, or polymeric materials used for fastenings or hinges for these enclosure types shall comply with the Ultraviolet Light Exposure Test and the Water Exposure and Immersion Test in the Standard for Polymeric Materials - Use in Electrical Equipment Evaluations, UL 746C.

*Exception No. 1: Compliance of elastomeric materials shall be demonstrated by the absence of any permanent damage such as distortion of the boot or fitting, or cracking or splitting of the material, following the exposure to ultraviolet light and water as described in UL 746C, and the subsequent impact test described in Section SB6.*

*Exception No. 2: A part fully internal to the environmental enclosure is not required to comply with this requirement.*

**UL COPYRIGHTED MATERIAL –  
NOT AUTHORIZED FOR FURTHER REPRODUCTION OR  
DISTRIBUTION WITHOUT PERMISSION FROM UL**

## SB5 Gaskets

SB5.1 The requirements in this section apply to gaskets that are required for an electrical enclosure to maintain a tight fit or to comply with the enclosure performance requirements when the wiring device is unmated or fully connected to its intended mating device.

SB5.2 A gasket shall be secured with adhesive or by mechanical means, including force-fit or the combination of the gasket's shape and elastomeric properties. The gasket and its securing means shall not be damaged when the cover is opened.

SB5.3 The gasket material shall comply with the Standard for Gaskets and Seals, UL 157.

## PERFORMANCE

### SB6 General

SB6.1 The enclosure of a device shall comply with the requirements and tests specified in Table SB6.1 for the particular environmental enclosure type appropriate for the intended use and description of the device. Requirements and test descriptions are contained in the Standard for Enclosures for Electrical Equipment, UL 50, except as modified in this section. All tests are to be conducted using:

- a) One set of representative devices unmated, with shrouds and flap or screw covers in place, and
- b) One set of representative devices fully connected to their intended mating devices with any enclosure securement means engaged or in place. This set of devices consists of connected combinations of either attachment plugs and receptacles, cord connectors and inlets, or attachment plugs and cord connectors.

SB6.2 An attachment plug or cord connector is to be wired with the appropriate size and type of flexible cord in accordance with the manufacturer's instructions. The free ends of flexible cord are to be sealed against moisture ingress. When assemblies consist of either an attachment plug or cord connector unmated or of an attachment plug and cord connector fully connected together, the assemblies are to be mounted to a horizontal board using clamps on the flexible cord within 4 – 10 inches (101 – 250 mm) of the strain relief of the device.

SB6.3 A receptacle or inlet is to be mounted to the appropriate representative outlet box, wall or panel surface and connected to a wiring system in accordance with the manufacturer's instructions. If the device is provided with a knockout or hub, a short length of the appropriate type of conduit or tubing with its free end sealed to reduce the likelihood of entrance of moisture is to be connected to the device. To equalize the pressure between the enclosure cavity interior and exterior during the Rain Test, the Hose and Hosedown Tests, and the Submersion Test in the Standard for Enclosures for Electrical Equipment, UL 50, the conduit or tubing is permitted to be vented to an area outside of where moisture may enter through the vent. Prior to subjecting the receptacle or inlet to the Rain Test or the Hose and Hosedown Tests, a self-closing cover that requires positioning or movement in normal use shall remain functional and comply with the requirements of the Rain Test after 1000 cycles of operation.

**UL COPYRIGHTED MATERIAL –  
NOT AUTHORIZED FOR FURTHER REPRODUCTION OR  
DISTRIBUTION WITHOUT PERMISSION FROM UL**

**Table SB6.1  
Environmental enclosure types**

Type	Intended use and description	Requirements or qualification tests from UL 50
2	Indoor use primarily to provide a degree of protection against limited amounts of falling water and dirt.	Corrosion protection (5.3) or Rust Resistance Test, Drip Test, Gaskets, Gasket Tests
3	Outdoor use primarily to provide a degree of protection against rain, sleet, wind blown dust and damage from external ice formation.	Rain Test, Dust Test or the hose test described in the Hose and Hosedown Tests, Icing Test, Outdoor Enclosures, Indoor Enclosures, Corrosion Resistant Enclosures, Gaskets, Gasket Tests
3R	Outdoor use primarily to provide a degree of protection against rain, sleet, and damage from external ice formation.	Rain Test, Icing Test, Outdoor Enclosures, Indoor Enclosures, Corrosion Resistant Enclosures, Gaskets, Gasket Tests
3S	Outdoor use primarily to provide a degree of protection against rain, sleet, windblown dust and to provide for operation of external mechanisms when ice laden.	Rain Test, Outdoor method of the Dust Test or the hose test described in the Hose and Hosedown Test, Icing Tests, Outdoor Enclosures, Indoor Enclosures, Corrosion Resistant Enclosures, Gaskets, Gasket Tests
4	Indoor or outdoor use primarily to provide a degree of protection against windblown dust and rain, splashing water, hose-directed water and damage from external ice formation.	Hosedown test described in the Hose and Hosedown Tests, Outdoor Enclosures, Indoor Enclosures, Corrosion Resistant Enclosures, Icing Test, Gaskets, Gasket Tests
4X	Indoor or outdoor use primarily to provide a degree of protection against corrosion, windblown dust and rain, splashing water, hose-directed water and damage from external ice formation.	Hosedown test described in the Hose and Hosedown Tests, Outdoor Enclosures, Indoor Enclosures, Corrosion Resistant Enclosures, Corrosion Resistance Test, Icing Test, Gaskets, Gasket Test

**UL COPYRIGHTED MATERIAL –  
NOT AUTHORIZED FOR FURTHER REPRODUCTION OR  
DISTRIBUTION WITHOUT PERMISSION FROM UL**

Table SB6.1 Continued on Next Page

Table SB6.1 Continued

Type	Intended use and description	Requirements or qualification tests from UL 50
5	Indoor use primarily to provide a degree of protection against settling airborne dust, falling dirt, and dripping noncorrosive liquids.	Corrosion protection (5.3) or Rust Resistance Test, Drip Test, Indoor settling airborne dust method of the Dust Test or the Atomized Water Test – method B of the Atomized Water Test, Gaskets, Gasket Tests
6	Indoor or outdoor use primarily to provide a degree of protection against hose-directed water, and the entry of water during occasional temporary submersion at a limited depth and damage from external ice formation.	Hosedown test described in the Hose and Hosedown Tests, Icing Tests, Submersion Tests, Outdoor Enclosures, Indoor Enclosures, Corrosion Resistant Enclosures, Gaskets, Gasket Tests
6P	Indoor or outdoor use primarily to provide a degree of protection against hose-directed water, the entry of water during prolonged submersion at a limited depth and damage from external ice formation.	Hosedown test described in the Hose and Hosedown Tests, Icing Test, Outdoor Enclosures, Indoor Enclosures, Corrosion Resistant Enclosures, Air Pressure Test, Gaskets, Gasket Tests
12, 12K	Indoor use primarily to provide a degree of protection against circulating dust, falling dirt, and dripping noncorrosive liquids.	Corrosion protection (5.3) or Rust Resistance Test, Drip Test, Indoor circulating airborne method of the Dust Test or the Atomized Water Test – method A of the Atomized Water Test, Gaskets, Gasket Tests
13	Indoor use primarily to provide a degree of protection against dust, spraying of water, oil, and noncorrosive coolant.	Corrosion protection (5.3) or Rust Resistance Test, Oil Test, Gaskets, Gasket Test

SB6.4 When conducting the Rain Test, the Drip Test, the Hose and Hosedown Tests, and the Submersion Test in the Standard for Enclosures for Electrical Equipment, UL 50, talcum powder, a moisture-indicating paste, or other similar moisture indicator is to be used. The moisture indicator is to be placed within the environmental enclosure in any area where moisture can come into contact with live parts, and between the faces of the mated devices. Moisture on exposed blades is acceptable only for an unmated attachment plug or inlet that is not provided with a means to maintain the integrity of the specified enclosure type in the blade area. Water is permitted on the face of the device as a result of the Rain Test, the Drip Test, the Hose and Hosedown Tests, and the Submersion Test.

SB6.5 The Rain Test and the Drip Test are not required to be conducted when the enclosure complies with the Hose and Hosedown Tests. Table SB6.2 lists other acceptable substitutes for specific qualification tests from the Standard for Enclosures for Electrical Equipment, UL 50.

**UL COPYRIGHTED MATERIAL –  
NOT AUTHORIZED FOR FURTHER REPRODUCTION OR  
DISTRIBUTION WITHOUT PERMISSION FROM UL**



**Table SB6.2  
Acceptable test substitutes**

Qualification test from UL 50	Acceptable substitute for the qualification test	Special conditions
Rain Test	Hose or Hosedown Test	None
Drip Test	Hose or Hosedown Test	None
Dust Test (Outdoor method)	Hose test described in Hose or Hosedown Test	None
Dust Test (Indoor circulating airborne method)	Atomized Water Test– Method A or the Hose or Hosedown Tests	None
Dust Test (Indoor circulating airborne method and indoor settling airborne method)	Atomized Water Test– Method B or the Hose or Hosedown Tests	None
Dust Test	Submersion Test	Enclosure tested without pipe thread sealing compound
Dust Test	Oil Test	None
Drip Test	Oil Test	None
Air Pressure Test	Submersion Test	Enclosure does not have connections for pressurizing the interior and the duration of the submersion is increased from 30 minutes to 24 hours

SB6.6 The Dust Test is not required to be conducted when the enclosure complies with the Submersion Test. For the devices covered by this supplement, the Submersion Test is not an acceptable substitute for the Hose and Hosedown Tests.

SB6.7 An attachment plug, receptacle, inlet, or cord connector shall also comply with the Crushing Resistance Test described in the Standard for Polymeric Materials - Use in Electrical Equipment Evaluations, UL 746C. An inlet or receptacle shall also comply with the ball impact test described in the Resistance to Impact Test contained in UL 746C while an attachment plug or cord connector shall comply with the Impact Test (Plugs and Connectors) described in the Standard for Plugs, Receptacles, and Cable Connectors, of the Pin and Sleeve Type, UL 1682.

SB6.8 The ball impact test mentioned in SB6.7 is to be conducted:

- a) At room temperature for all devices,
- b) Immediately after being conditioned for three hours in a cold chamber at -35°C (-31°F) for devices intended for outdoor use, in lieu of conducting the test at room temperature, and
- c) Immediately after being conditioned for three hours in a cold chamber at 0°C (32°F) for devices intended for indoor-use only in locations where the temperature is less than actual room conditions, such as in an unheated garage.

**UL COPYRIGHTED MATERIAL –  
NOT AUTHORIZED FOR FURTHER REPRODUCTION OR  
DISTRIBUTION WITHOUT PERMISSION FROM UL**

## MARKINGS

### SB7 General

SB7.1 A device with an environmental enclosure rating shall be marked "Enclosure Type(s) \_\_\_\_\_," "Enc. Type(s) \_\_\_\_\_," "Enc. \_\_\_\_\_," or the equivalent, where the blank is to be filled in with one or more of the enclosure type designations specified in Table SB6.1. An enclosure that complies with the performance requirements only when its cover or cap is closed and that has a cover or cap which is not self-closing shall be marked "Enclosure Type \_\_\_\_\_ When Cover Closed," or the equivalent, where the blank is to be filled in with the type designation. An enclosure that complies with the performance requirements only when the device is fully connected to its intended mating device shall be marked "Enclosure Type \_\_\_\_\_ When Connected," or the equivalent, where the blank is to be filled in with the type designation. The markings shall be visible after installation on the outer enclosure of the device or on the inner or outer surface of the cover or cap. When a part of an environmental enclosure is completely removable without the use of a tool, the enclosure type designation shall be marked only on the removable part. (See SB3.4). An enclosure that requires an additional locking, latching or detent action of a self-closing cover or cap to comply with the performance requirements shall be additionally marked to indicate that action where visible after installation on the outer surface of the cover or cap.

SB7.2 The required markings shall be:

- a) Molded or die-stamped,
- b) Paint-stenciled or ink-stamped,
- c) Stamped or etched onto a metal plate that is permanently secured to the outer enclosure, or
- d) Provided on a pressure-sensitive label or a label secured by cement or adhesive.

SB7.3 A required marking shall be capable of withstanding the stresses of ordinary usage, including exposure to weather and other ambient conditions, handling, storage, and similar conditions. An adhesive-backed label shall comply with the requirements in the Standard for Marking and Labeling Systems, UL 969, for the exposure conditions and surface temperatures indicated in Table SB7.1.

*Exception No. 1: The need for exposure tests on forms of marking other than labels shall be individually evaluated.*

*Exception No. 2: A rated surface temperature other than those specified in Table SB7.1 is able to be used when it is demonstrated that the temperature is not exceeded in service.*

SB7.4 For an attachment plug or cord connector with an environmental enclosure rating, the installation instructions or smallest unit container of the device shall be marked "Enclosure Type \_\_\_\_\_ When Mated With \_\_\_\_\_," or the equivalent, where the first blank is to be filled in with the type designation and the second blank is to be filled in with the identification of the line of mating devices intended to be used with the device in order for that device to comply with the environmental enclosure requirements corresponding to that type designation.

SB7.5 For a receptacle or inlet with an environmental enclosure rating, the installation instructions or smallest unit container of the device shall be marked "Enclosure Type \_\_\_\_\_ When Mated With \_\_\_\_\_ and Installed With \_\_\_\_\_," or the equivalent, where the first and second blanks are to be filled in as indicated in SB7.4, and the third blank is to be filled in with the identification of any necessary outlet box or cabinet, conduit, or cord fitting, sealing material, preparatory or finishing actions, and any similar information concerning the installation of the device into the overall enclosure, in order for that device to comply with the environmental enclosure requirements corresponding to that type designation.

SB7.6 A receptacle with an integral outlet box cover is able to be marked "Wet Location," "Damp Location," or "Wet Location Only When Cover Closed" when the cover complies with SB3.2.

SB7.7 A Type 6 or 6P disconnectable device that can be disconnected from its intended mating device without the use of a tool after the devices have been installed as intended, fully connected, and submerged shall be marked, "CAUTION" and the following or the equivalent: "Risk of Shock. Do not disconnect while connectors are submerged."

SB7.8 When the acceptability of the environmental enclosure rating of a receptacle or inlet is dependent upon a particular mounting orientation, the enclosure shall be marked to indicate the required orientation.

*Exception No. 1: The enclosure is not required to be marked when the installation instructions or smallest unit container of the receptacle or inlet indicates the required orientation.*

*Exception No. 2: The enclosure of a Type 2 or 3R receptacle or inlet dependent upon the particular mounting orientation of a specific Type 2 or 3R outlet box, or other portion of the environmental enclosure which includes a means for connection to a conduit, raceway, or other wiring system is not required to be marked when the outlet box, cabinet, junction box, or other portion of the environmental enclosure bears its own orientation marking and is specifically identified in the installation instructions or smallest unit container of the receptacle or inlet.*

*Exception No. 3: The enclosure of a Type 2 or 3R receptacle or inlet dependent upon the particular mounting orientation of an unspecified outlet box, cabinet, junction box, or other portion of the environmental enclosure which includes a means for connection to a conduit, raceway, or other wiring system, is not required to be marked when the installation instructions or smallest unit container of the receptacle or inlet indicate the required orientation of the outlet box, cabinet, junction box, or other portion of the environmental enclosure.*

**UL COPYRIGHTED MATERIAL –  
NOT AUTHORIZED FOR FURTHER REPRODUCTION OR  
DISTRIBUTION WITHOUT PERMISSION FROM UL**

**Table SB7.1  
Label exposure conditions**

<b>Enclosure type number</b>	<b>Label exposure conditions</b>	<b>Maximum surface temperature °C (°F)</b>	<b>Minimum surface temperature °C (°F)</b>
2	Indoor locations where exposed to high humidity or occasional exposure to water	60 (140)	0 (32)
3, 3R, 3S, 4, 4X, 6, 6P	Indoor or outdoor locations where exposed to high humidity or occasional exposure to water	80 (176)	-35 (-31)
5, 12, 12K, 13	Indoor locations where exposed to high humidity or occasional exposure to water; additional conditions depending upon the application	60 (140)	0 (32)

## SUPPLEMENT SC - MARINE SHORE POWER INLETS

### INTRODUCTION

#### SC1 Scope

SC1.1 The requirements of this supplement cover marine shore power inlets rated at not less than 20 A and not more than 50 A, 250 V maximum. These devices are intended for use with marine shore power cable sets to extend the shore power supply from a shore-installed power outlet to a boat, in accordance with the applicable requirements in the American Boat and Yacht Council (ABYC) Std. E-8-1985, National Fire Protection Association Standard for Pleasure and Commercial Motor Craft, NFPA No. 302-1987, and the United States Coast Guard (USCG) Regulations Title 33, Chapter 1, CFR, Part 183.

#### SC2 Glossary

SC2.1 For the purpose of this supplement, the following definitions apply.

SC2.2 FACE COVER – A threaded or hinged cover intended to restrict water from coming in contact with the male blades of a shore power inlet when it is not connected to a shore power cable set.

SC2.3 SHORE POWER CABLE SET – A length of flexible cord or cable assembled with a locking-type grounding attachment plug as a line fitting and a locking-type grounding cord connector as a load fitting intended to be used to supply shore power to boats that are moored to a dock.

SC2.4 SHORE POWER INLET A boat-mounted inlet (motor attachment plug) intended to provide connection for a shore power cable set.

#### SC3 General

SC3.1 A marine shore power inlet shall comply with the requirements for inlets in this standard and the requirements for wet-location cover plates in the Standard for Metallic Outlet Boxes, UL 514A, the Standard for Nonmetallic Outlet Boxes, Flush Device Boxes, and Covers, UL 514C, or the Standard for Cover Plates for Flush-Mounted Wiring Devices, UL 514D, as applicable, except as modified by the requirements in this supplement.

**UL COPYRIGHTED MATERIAL –  
NOT AUTHORIZED FOR FURTHER REPRODUCTION OR  
DISTRIBUTION WITHOUT PERMISSION FROM UL**

## CONSTRUCTION

### SC4 General

SC4.1 A shore power inlet shall employ a L5-20P, L5-30P, L6-20P, L6-30P, L14-20P, L14-30P, L15-20P, L15-30P, L21-20P, L21-30P, SS1-50P, or SS2-50P configuration.

SC4.2 A shore power inlet shall be provided with a threaded hub and a threaded or hinged face cover. The hub and the face cover, if threaded, shall have a 2-3/4 – 16, Class 2 thread having at least three full threads. A shore power inlet shall be dimensioned to couple with a shore power cable set load fitting of a corresponding configuration. The face cover shall be positively retained in place on the shore power inlet. See Table SC4.1 and Figure SC4.1 for the required dimensions.

**Table SC4.1**  
**Dimensions for a shore power inlet as shown in Figure SC4.1**

Rating	Shore power inlet		NEMA WD6 designation
	inches (mm)		
	A <sup>a</sup>	B	
20A, 125 V, 1 Phase, 2 Pole, 3 Wire	1.880 (47.75)	0.921 <sup>b</sup> (23.39)	L5-20P
30 A, 125 V, 1 Phase, 2 Pole, 3 Wire	1.880 (47.75)	1.000 <sup>b</sup> (25.40)	L5-30P
20 A, 250 V, 1 Phase, 2 Pole, 3 Wire	1.880 (47.75)	0.921 <sup>b</sup> (23.39)	L6-20P
30 A, 250 V, 1 Phase, 2 Pole, 3 Wire	1.880 (47.75)	1.000 <sup>b</sup> (25.40)	L6-30P
20 A, 125/250 V, 1 Phase, 3 Pole, 4 Wire	2.000 (50.80)	0.921 <sup>b</sup> (23.39)	L14-20P
30 A, 125/250 V, 1 Phase, 3 Pole, 4 Wire	2.000 (50.80)	1.000 <sup>b</sup> (25.40)	L14-30P
20 A, 250 V, 3 Phase, 3 Pole, 4 Wire	2.000 (50.80)	0.921 <sup>b</sup> (23.39)	L15-20P
30 A, 250 V, 3 Phase, 3 Pole, 4 Wire	2.000 (50.80)	1.000 <sup>b</sup> (25.40)	L15-30P
20 A, 208Y/120 V, 3 Phase, 4 Pole, 5 Wire	2.000 (50.80)	0.921 <sup>b</sup> (23.39)	L21-20P
30 A, 208Y/120 V, 3 Phase, 4 Pole, 5 Wire	2.000 (50.80)	1.000 <sup>b</sup> (25.40)	L21-30P
50 A, 125 V, 1 Phase, 2 Pole, 3 Wire	2.015 (51.18)	1.163 <sup>c</sup> (29.54)	SS1-50P
50 A, 125/250 V, 1 Phase, 3 Pole, 4 Wire	2.015 (51.18)	1.163 <sup>c</sup> (29.54)	SS2-50P
<sup>a</sup> Minimum dimension. <sup>b</sup> Tolerance of minus 0, plus 0.031 (plus 0.79 mm). <sup>c</sup> Maximum dimension.			

SC4.3 With the face cover in the closed position, the construction of a shore power inlet shall not permit water to enter the inlet and contact the blades or face of the device as determined by the Water-Spray Test, Section SC11.

Figure SC4.1  
Dimensions of a shore power inlet

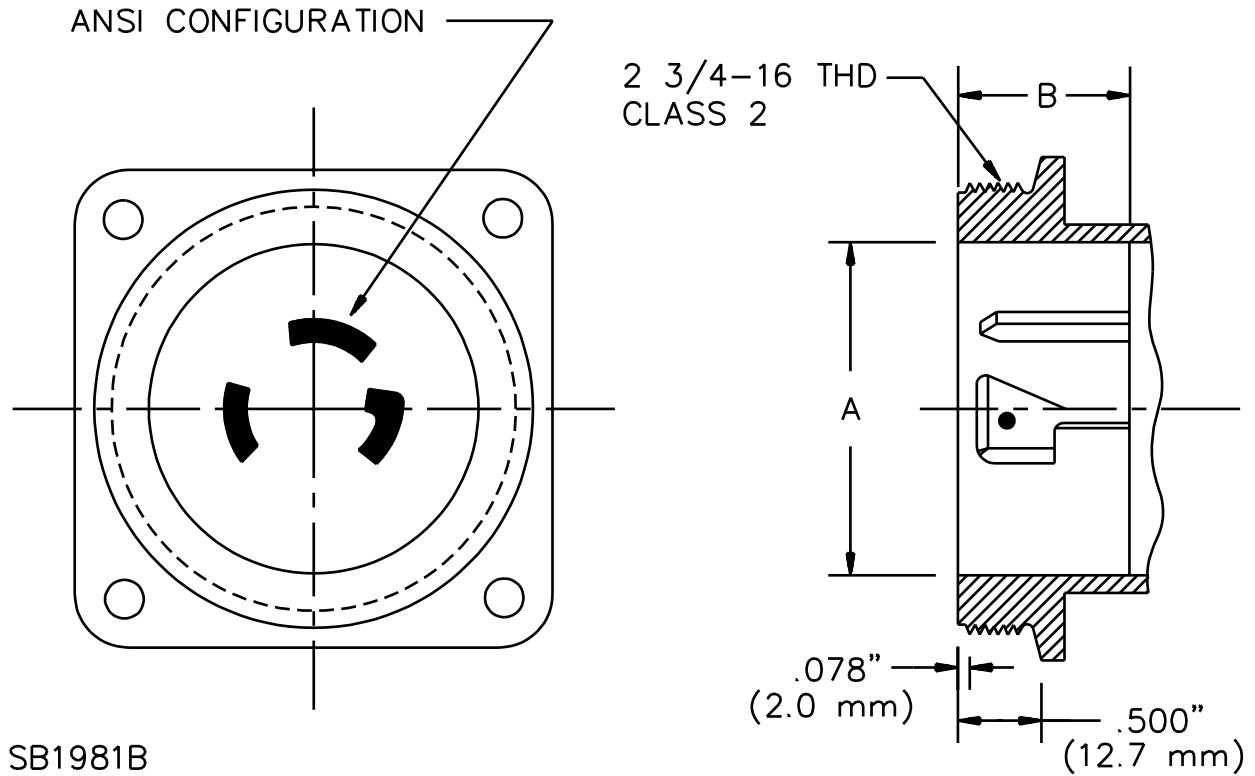

Document Was Downloaded By jianxiang chen For Use By KAI HUA (FOSHAN SHUNDE) ELECTRIC APPLIANCE CO LTD 22381 : 5/8/2008 - 10:34 AM

## SC5 Insulating Materials

SC5.1 An insulating material employed in a shore power inlet shall comply with the Ultraviolet Light Exposure Test and the Water Exposure and Immersion Test in the Standard for Polymeric Materials – Use in Electrical Equipment Evaluations, UL 746C.

*Exception: A material used only on the blade face or rear housing of the shore power inlet is not required to be subjected to the Ultraviolet Light Exposure Test.*

## SC6 Corrosion Resistance

SC6.1 All current-carrying parts shall be copper alloy. The blades of the shore power inlet shall be provided with a corrosion-resistant plating.

SC6.2 Noncurrent-carrying metal parts, such as metal strain-relief clamps or hinges that are depended upon to meet the requirements of the standard, shall be galvanically compatible with other metal parts of the shore power inlet, and shall provide corrosion resistance equivalent to that of:

- a) Stainless steel alloys 302, 304, 410, or 430, or
- b) Bronze alloys with less than 15 percent zinc content.

SC6.3 If there is any question as to whether the parts are corrosion resistant, the Salt-Spray Test, Section SC8, shall be performed.

## PERFORMANCE

### SC7 General

SC7.1 A shore power inlet shall be subjected to the Mechanical Strength Test, Section SC10, the Water-Spray Test, Section SC11, and the Shock Test, Section SC12. If necessary to determine compliance with the corrosion resistance requirements in SC6.2, a shore power inlet shall also be subjected to the Salt-Spray Test, Section SC8, and the Dielectric Voltage-Withstand Test, Section SC9.

### SC8 Salt-Spray Test

SC8.1 If necessary to determine compliance with the corrosion resistance requirement in SC6.2, a shore power inlet shall be exposed to salt spray (fog) as described in SC8.2. Following the exposure, the shore power inlet shall comply with the Dielectric Voltage-Withstand Test, Section SC9, the Mechanical Strength Test, Section SC10, and the Water-Spray Test, Section SC11.

SC8.2 The salt spray exposure is to be conducted for a period of 750 hours in accordance with the Standard Practice for Operating Salt Spray (Fog) Apparatus, ASTM B117.



**SC9 Dielectric Voltage-Withstand Test**

SC9.1 After being subjected to the Salt-Spray Test, Section SC8, a shore power inlet shall withstand without breakdown the application of a 60 Hz essentially sinusoidal potential of 1250 V applied for 1 minute between live parts of opposite polarity and between live parts and accessible dead metal parts.

SC9.2 The test potential is to be supplied from a 500 VA or larger capacity testing transformer whose output is essentially sinusoidal and can be varied. The applied potential is to be increased from zero until the required test voltage is reached, and is to be held at that voltage for a period of 1 minute. The increase in the applied potential is to be at a uniform rate that is as rapid as is consistent with its value being correctly indicated by the voltmeter.

**SC10 Mechanical Strength Test**

SC10.1 As a result of the test described in SC10.2 – SC10.4, there shall not be any cracking, breaking, or other physical deterioration of the shore power inlet.

SC10.2 One shore power inlet is to be installed on a platform as shown in Figure SC10.1. A 50 ft (15.2 m) shore power cable set is to be connected between the shore power inlet and a fixed end (to simulate its connection to a power inlet) as shown in the figure. The excess cord of the shore power cable set is to be coiled between the shore power inlet and the fixed point and taped at the base of the coil. During the test, the shore power cable set is to be free to move without striking any surface.

SC10.3 The platform is to be rotated to cause the mounted power inlet to move back and forth in a vertical direction through an angle of 30 degrees (15 degrees above and below the horizontal) for a total of 1000 cycles at a rate of 15 cycles per minute.

SC10.4 After completion of the 1000 cycles, the shore power inlet is to be visually examined for damage including cracking of the insulation materials, boots, and covers.

Figure SC10.1  
Mechanical strength test apparatus

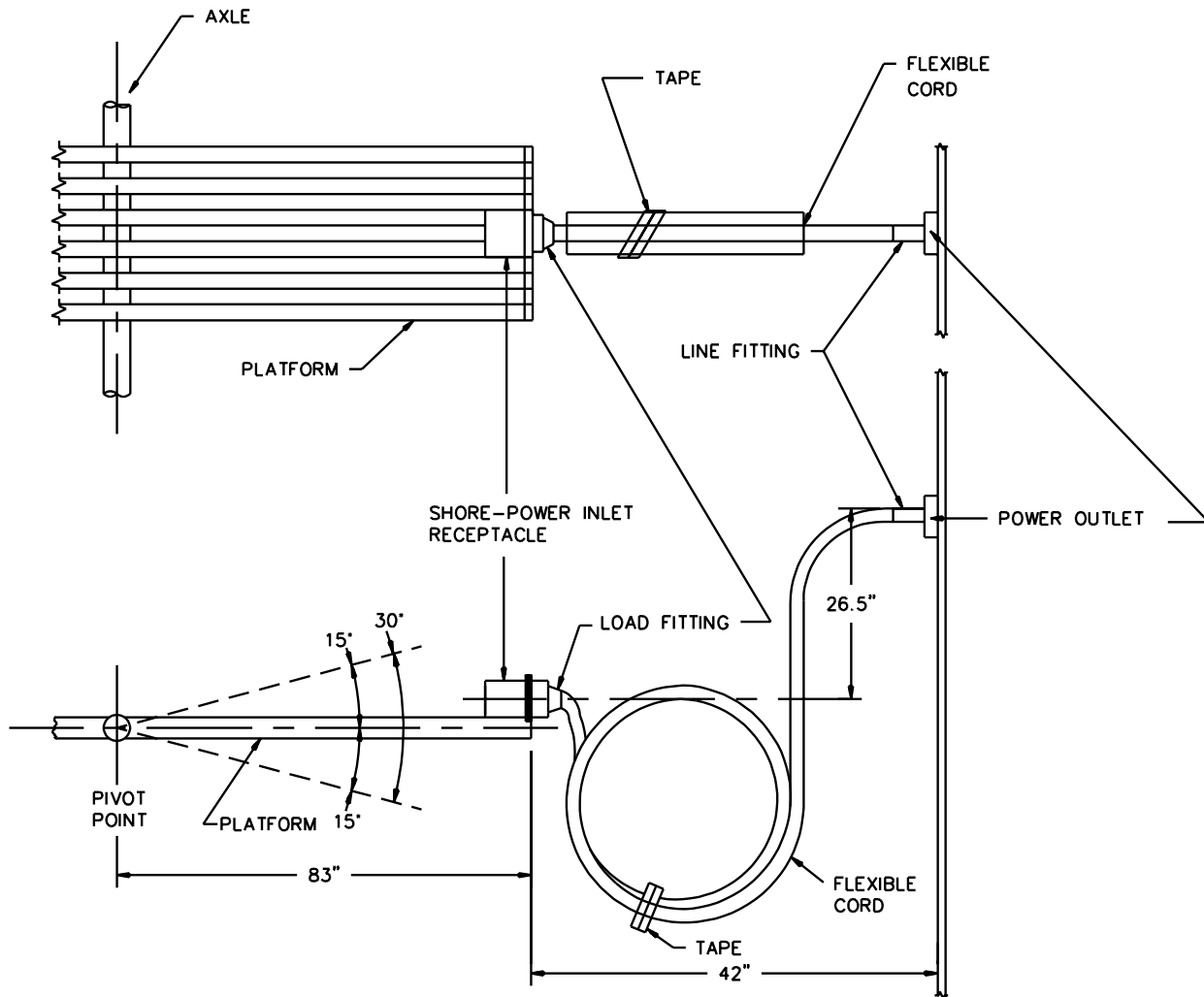

SB1968

inch	26.5	42	83
mm	673	1067	2108

UL COPYRIGHTED MATERIAL –  
NOT AUTHORIZED FOR FURTHER REPRODUCTION OR  
DISTRIBUTION WITHOUT PERMISSION FROM UL

### SC11 Water-Spray Test

SC11.1 As a result of the test described in SC11.2 – SC11.4, water shall not contact the current-carrying parts of a shore power inlet.

SC11.2 One shore power inlet is to be mounted to a vertical wall section with its face cover in the closed position.

SC11.3 The shore power inlet is then to be sprayed with water for one hour. The water-spray apparatus is to consist of three spray heads mounted in a water-supply pipe rack as illustrated in Figure SC11.1. The spray heads are to be constructed in accordance with Figure SC11.2. The water-supply pipe rack with spray heads is to be located so that the focal point of the spray is at the face cover of the shore power inlet. The water pressure is to be maintained at 5 lbs/in<sup>2</sup> (34 kPa) at each spray head.

SC11.4 After being subjected to the water spray described in SC11.3, the outside surface of the shore power inlet is to be wiped dry. The face cover is then to be opened and inspected for any water entry.

Figure SC11.1  
Water-spray-head piping  
PLAN VIEW

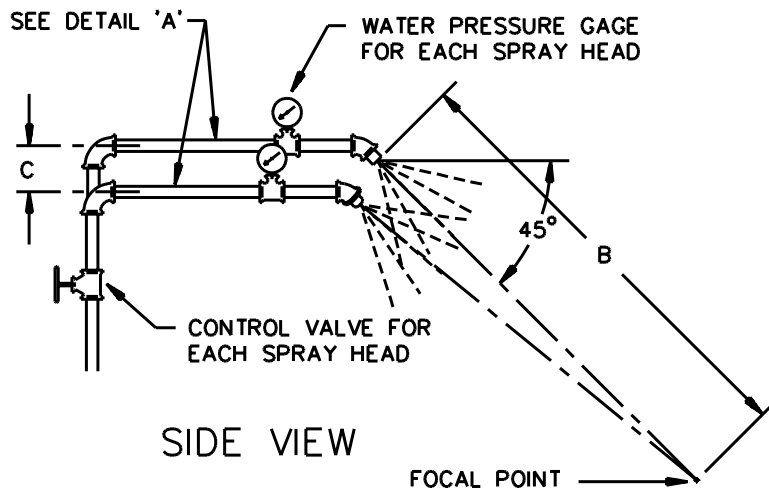
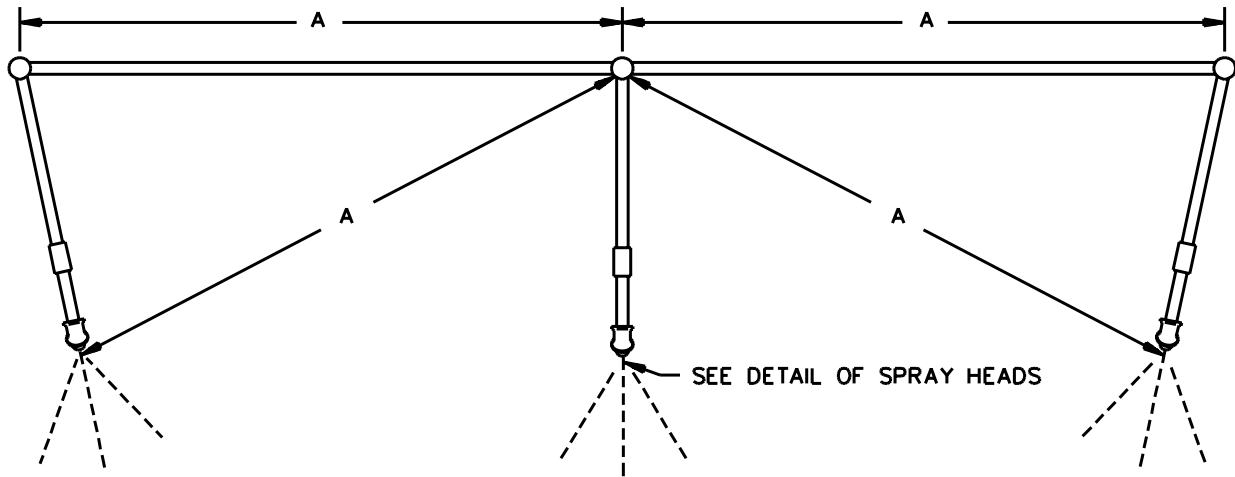

PIEZOMETER ASSEMBLY  
DETAIL 'A'

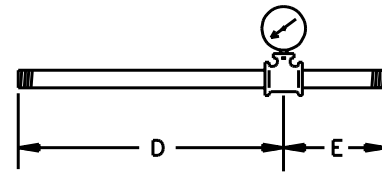

SIDE VIEW

RT101B

Item	Inch	mm
A	28	710
B	55	1400
C	2-1/4	55
D	9	230
E	3	75

UL COPYRIGHTED MATERIAL –  
NOT AUTHORIZED FOR FURTHER REPRODUCTION OR  
DISTRIBUTION WITHOUT PERMISSION FROM UL

Figure SC11.2  
Water-spray head

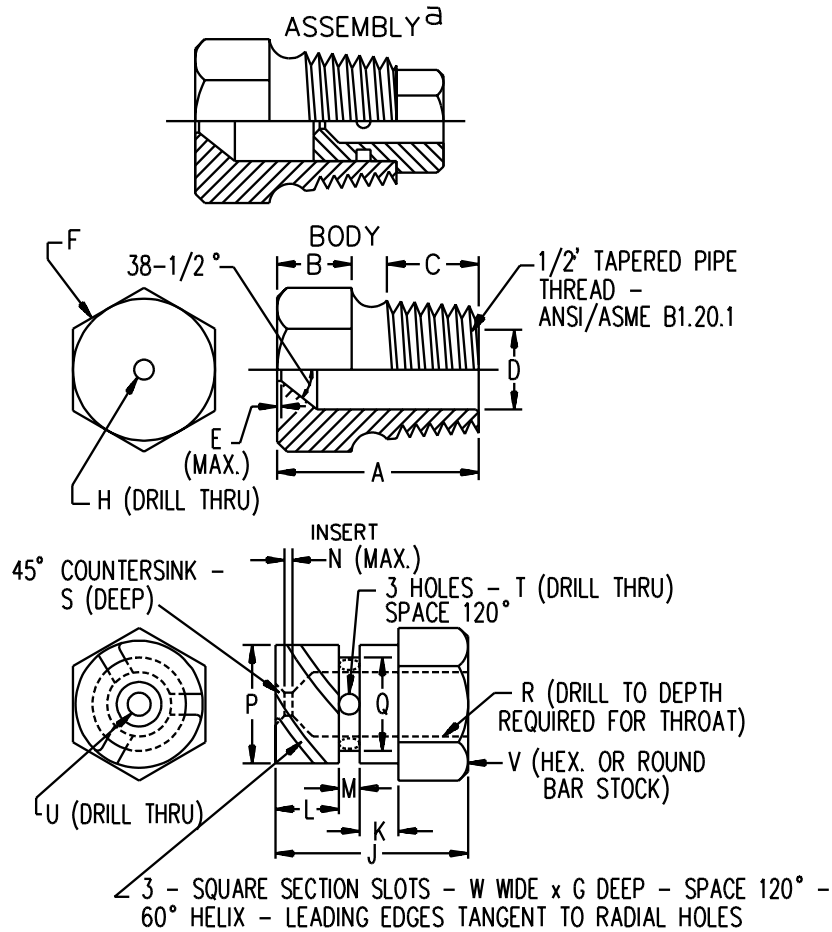

Item	inch	mm	Item	inch	mm
A	1-7/32	31.0	N	1/32	0.80
B	7/16	11.0	P	.575	14.61
C	9/16	14.0		.576	14.63
D	.578	14.68	Q	.453	11.51
	.580	14.73		.454	11.53
E	1/64	0.40	R	1/4	6.35
F	c	c	S	1/32	0.80
G	.06	1.52	T	(No. 35) <sup>b</sup>	2.80
H	(No. 9) <sup>b</sup>	5.0	U	(No. 40) <sup>b</sup>	2.50
J	23/32	18.3	V	5/8	16.0
K	5/32	3.97	W	0.06	1.52
L	1/4	6.35			
M	3/32	2.38			

<sup>a</sup> Nylon Rain-Test Spray Heads are available from Underwriters Laboratories

<sup>b</sup> ANSI B94.11M Drill Size

<sup>c</sup> Optional - To serve as a wrench grip.

RT100E

UL COPYRIGHTED MATERIAL -  
NOT AUTHORIZED FOR FURTHER REPRODUCTION OR  
DISTRIBUTION WITHOUT PERMISSION FROM UL

## SC12 Shock Test

SC12.1 As a result of the test described in SC12.2 – SC12.4:

- a) There shall not be any cracking, breaking, or physical deterioration of the shore power inlet, and
- b) No portion of the flexible cord attached to the wiring terminals of the shore power inlet shall pull out of the device.

SC12.2 One device is to be mounted on a 0.135 inch (3.43 mm) steel or aluminum panel that is in turn to be secured in a vertical plane to a rigid test fixture. The assembly (inlet, panel, and fixture) is then to be secured to a shock table. See Figure SC12.1.

SC12.3 The device is to be wired with flexible cord of the appropriate size for the device rating and torqued to simulate a normal installation. The opposite end of the cord is to be secured to a point located off the shock table platform at a point within 18 inches (457 mm) of the terminals.

SC12.4 The assembly (device, fixture, and cord) is to be subjected to 1000 shock impacts of 10 g [322 ft/s<sup>2</sup> (98 m/s<sup>2</sup>)] peak acceleration and 20 – 25 milliseconds duration as measured at the base of the half-sine shock wave envelope. The test is to be conducted at room temperature.

**Figure SC12.1**  
**Shock test**

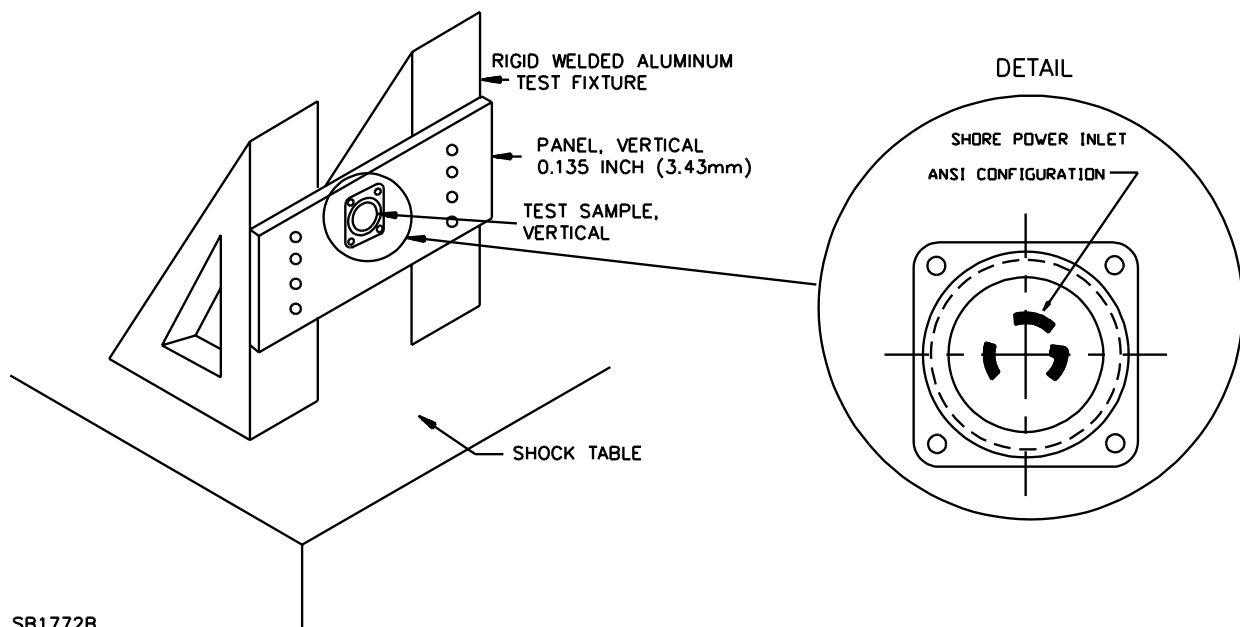

SB1772B

**UL COPYRIGHTED MATERIAL –  
NOT AUTHORIZED FOR FURTHER REPRODUCTION OR  
DISTRIBUTION WITHOUT PERMISSION FROM UL**

## SUPPLEMENT SD - HOSPITAL GRADE DEVICES

### INTRODUCTION

#### SD1 Scope

SD1.1 The requirements of this supplement cover Hospital Grade attachment plugs, cord connectors, and receptacles, intended for hospital use in other than hazardous locations in accordance with Article 517 of the National Electrical Code, ANSI/NFPA 70. They are applicable only to nonlocking-type devices of the 5-15, 6-15, 5-20, and 6-20 configurations. Receptacles shall be intended only for flush installation, and plugs and connectors shall be either of the straight type (flexible cord exits at the rear of the device) or angled type (cord exits at an angle to the major plug axis) intended for field assembly on flexible cord.

SD1.2 A Hospital Grade device shall comply with the applicable requirements of this standard, UL 498, except as modified by the requirements in this supplement.

SD1.3 Other types such as factory assembled plugs and connectors, devices having locking-type configurations, or devices for hazardous locations may be investigated based on the requirements in this supplement along with any modifications needed to adequately represent the expected use of the device.

SD1.4 These requirements do not cover Hospital Grade molded-on attachment plugs of power-supply cords.

### CONSTRUCTION

#### SD2 General

SD2.1 To provide strain relief for an attachment plug or cord connector, the clamp shall be capable of being easily tightened on the specified flexible cords to grip both the jacket and individually insulated conductors so that forces exerted on the cord (pushing or pulling) are not transmitted to the wiring terminal. See also Strain Relief Tests, Sections SD5 and SD19.

SD2.2 The wiring terminals of an attachment plug or cord connector shall be located in individual insulating compartments (wiring terminal enclosures) with no joints or seams through which stray strands of the conductor can pass during wiring. The wiring terminal compartment insulating walls or barriers are to either:

- a) Extend not less than 1/32 inch (0.79 mm) above metal parts of wired terminals and provide a spacing between metal parts of adjacent wire terminals of not less than 3/32 inch (2.38 mm) through air and over surface,
- b) Extend not less than to be flush with metal parts of wired terminals and provide a spacing between metal parts of adjacent wired terminals of not less than 1/4 inch (6.35 mm) through air and over surface, or
- c) Extend over the top of the terminal compartments with a wire clearance hole in the insulating wall or cover sized to:
  - 1) Accept the individual wire insulation, or
  - 2) Be spaced not less than 1/4 inch (6.35 mm) apart as measured from the periphery of each hole.

**UL COPYRIGHTED MATERIAL –  
NOT AUTHORIZED FOR FURTHER REPRODUCTION OR  
DISTRIBUTION WITHOUT PERMISSION FROM UL**

SD2.3 The housing of an attachment plug or cord connector that is grasped in handling the device shall be an insulating material with no accessible metal parts on the outside that extend into wiring or cord compartments that may contain unclamped or stray flexible cord conductor strands. Metal strain relief clamps are not prohibited by this requirement.

SD2.4 The size of an attachment plug shall provide for the full insertion of two attachment plugs simultaneously into a duplex receptacle. Angle plugs may have their assemblies rotated to determine compliance.

SD2.5 The blades of an attachment plug shall be formed of solid brass material in conformance with Wiring Devices – Dimensional Specifications, ANSI/NEMA WD6. The grounding pin shall not be capable of being easily bent or removed without the use of tools.

SD2.6 The grounding contact of a cord connector or receptacle shall enable free insertion of a U-shaped grounding pin at any possible angle permitted by the clearance opening for the grounding pin.

## PERFORMANCE

### GENERAL

#### SD3 Representative Devices

SD3.1 A Hospital Grade attachment plug is to be subjected to the tests outlined in Table SD3.1 in addition to those outlined in Table 54.1.

SD3.2 A Hospital Grade cord connector is to be subjected to the tests outlined in Table SD3.2 in addition to those outlined in Table 54.3.

SD3.3 A Hospital Grade receptacle is to be subjected to the tests outlined in Table SD3.3 in addition to those outlined in Table 54.4.

**Table SD3.1**  
**Summary of tests<sup>a</sup>**  
**Hospital grade attachment plugs**

Section	Test sequences	No. of devices <sup>b</sup>	Details
SD5	Strain Relief – static pull	6	
SD5	Strain Relief – rotary pull	3	
SD5	Strain Relief – abrupt removal		
	Straight plugs	8	
	Angle plugs	16	
SD6	Crushing	6	
SD7	Impact Resistance	6	
SD8	Mechanical Drop	6	
SD9	Mold Stress Relief	6	May be combined with Mold Stress Relief Test in Section 58. See Table 54.1.

<sup>a</sup>To be conducted in addition to any applicable tests specified in Table 54.1.

<sup>b</sup>A set of representative devices may be used for more than one test sequence if agreeable to all concerned.

**UL COPYRIGHTED MATERIAL –  
NOT AUTHORIZED FOR FURTHER REPRODUCTION OR  
DISTRIBUTION WITHOUT PERMISSION FROM UL**



**Table SD3.2**  
**Summary of tests<sup>a</sup>**  
**Hospital grade cord connectors**

Section	Test sequences	No. of devices <sup>b</sup>	Details
SD11	Grounding Contact Temperature	8	
SD12	Resistance		
SD13	Grounding Contact Overstress	6	
SD14	Plug Connection and Separation		
SD15	Crushing	6	
SD16	Impact Resistance	6	
SD17	Mechanical Drop	6	
SD18	Mold Stress Relief	6	May be combined with Mold Stress Relief Test in Section 58. See Table 54.3.
SD19	Strain Relief – static pull	6	
SD19	Strain Relief– rotary pull	3	
SD19	Strain Relief – abrupt removal	8	

<sup>a</sup>To be conducted in addition to any applicable tests specified in Table 54.3.  
<sup>b</sup>A set of representative devices may be used for more that one test sequence if agreeable to all concerned.

**Table SD3.3**  
**Summary of tests<sup>a</sup>**  
**Hospital grade receptacles**

Section	Test sequences	No. of devices <sup>b</sup>	Details
SD21	Abrupt Plug Removal	8	
SD22	Grounding Contact Temperature		
SD23	Resistance		
SD24	Fault Current		Represents the Fault Current Test required by Section 116
SD25	Grounding Contact Overstress	6	
SD26	Terminal Strength	3	
SD27	Assembly Security	3	
SD28	Impact	6	
SD29	Mold Stress Relief	6	May be combined with the Mold Stress Relief Test in Section 58. See Table 54.4.

<sup>a</sup>To be conducted in addition to any applicable tests specified in Table 54.4.  
<sup>b</sup>A set of representative devices may be used for more than one test sequence if agreeable to all concerned.

## HOSPITAL GRADE ATTACHMENT PLUGS

### SD4 General

SD4.1 Unless otherwise stated, previously untested plugs are to be used for each test.

### SD5 Strain Relief Tests

#### SD5.1 General

SD5.1.1 After being subjected to the strain relief tests described in this section, there shall not be any displacement of the conductors, conductor insulation, or outer jacket of the flexible cord exceeding 1/32 inch (0.79 mm). There shall not be any cuts, rips, or tears in the cord insulation nor any breakage of the attachment plug that could adversely affect the enclosure of live parts, strain relief, or grounding path integrity.

SD5.1.2 Attachment plugs are to be assembled onto 12 inch (305 mm) lengths of flexible cord 24 hours before testing. The flexible cord is to be cut at right angles to its major axis (but not stripped) and placed in the plug with its conductors positioned as if they were to be connected to the terminals. A 20 A attachment plug is to be assembled onto 16 AWG (1.3 mm<sup>2</sup>), Type SJT cord. A 15 A plug is to be assembled onto 18 AWG (0.83 mm<sup>2</sup>), Type SVT cord except where the device is marked on or in the carton to specifically exclude the use of cords having a diameter of less than 0.300 inch (7.62 mm) in which case Type SJT cord having 18 AWG (0.83 mm<sup>2</sup>) conductors is to be used. Except for a device that is individually packaged with instructions for cord clamp installation indicating the torsional force to be applied, the clamp is to be tightened with a torque of 8 in-lbf (0.9 N·m). Straight-plug testing requires 17 assemblies; angle-plug testing requires 25.

SD5.1.2 revised November 16, 2007

#### SD5.2 Method A – static pull

SD5.2.1 Each of six devices previously assembled onto flexible cord is to be subjected to a gradually applied pull of 30 lbf (133 N) to the free end of the cord while supporting the attachment plug. The force is to be applied for 1 minute in a direction perpendicular to the plane of cord entry.

#### SD5.3 Method B – rotary pull

SD5.3.1 Each of three devices previously assembled onto flexible cord is to be subjected to a rotary cord motion while a 10 lbf (44.5 N) is applied for 2 hours. The cord is to be rotated at a rate of approximately 9 rpm in a 3 inch diameter (0.76 mm) circle at a point of 6 inches (152 mm) below the cord exit with the attachment plug rigidly mounted. (Note – This test is conveniently done with the UL secureness test apparatus described in the Standard for Wire Connectors, UL 486A-486B.)

SD5.3.1 revised November 16, 2007

**UL COPYRIGHTED MATERIAL –  
NOT AUTHORIZED FOR FURTHER REPRODUCTION OR  
DISTRIBUTION WITHOUT PERMISSION FROM UL**

**SD5.4 Method C – abrupt removal**

SD5.4.1 Each attachment plug previously assembled onto flexible cord as described in SD5.1.2 is to be subjected to one abrupt removal from a Hospital Grade duplex receptacle in accordance with the procedure described in this section. One half of the devices is to be tested using a receptacle that has the grounding contact integral with the strap. The remaining devices are to be tested with a receptacle having separate grounding contacts riveted to the strap. A new plug is to be used for each abrupt removal.

SD5.4.2 Each receptacle outlet to be used for conducting this test is first to be conditioned by ten cycles of full insertion and complete withdrawal of an attachment plug of the matching configuration having solid line blades and a U-shaped ground pin rigidly supported by the attachment plug body. Each conditioned outlet is then to retain the fully inserted test pin illustrated in Figure SD5.1 for not less than 1 minute with the receptacle face horizontal and the weight applied perpendicular to the face plane, tending to remove the pin. The displacement of the test pin shall not be greater than 0.079 inch (2 mm). Any receptacle that is unable to retain the test pin after the conditioning cycles is not to be used for conducting the abrupt removal test.

**UL COPYRIGHTED MATERIAL –  
NOT AUTHORIZED FOR FURTHER REPRODUCTION OR  
DISTRIBUTION WITHOUT PERMISSION FROM UL**

Figure SD5.1  
Standard grounding pin

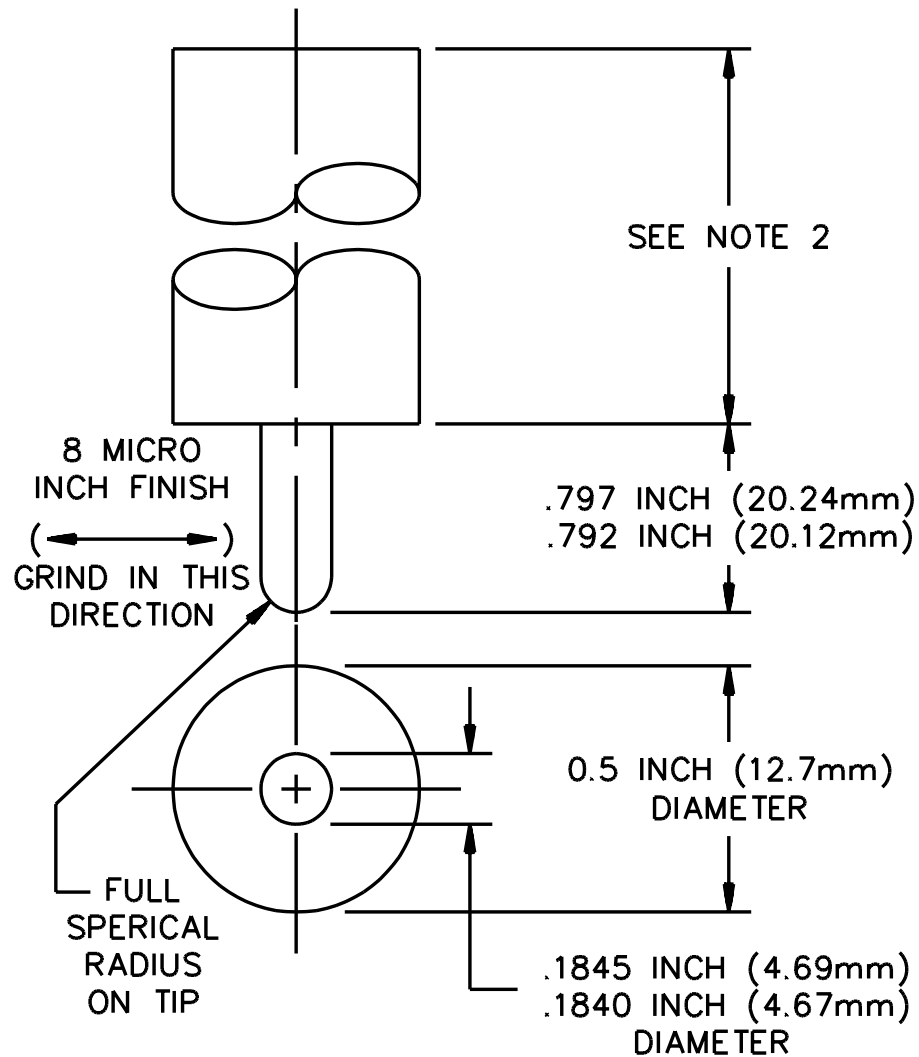

SB0704A

NOTES

- 1) All dimensions in inches.
- 2) Length not specified
- 3) Total tool weight of 4 oz (113 g).
- 4) Hardened steel pin.

microinch  
nanometer

8  
200

UL COPYRIGHTED MATERIAL –  
NOT AUTHORIZED FOR FURTHER REPRODUCTION OR  
DISTRIBUTION WITHOUT PERMISSION FROM UL

SD5.4.3 Each receptacle is then to be mounted to represent a typical installation and a 0.030 plus 0.003 minus 0.0 inch (0.76 plus 0.08 minus 0.0 mm) thick steel faceplate rigidly mounted as intended, being supported around its perimeter. The receptacle face is to be in a vertical plane in a manner that will facilitate the test orientations described in SD5.5.1 and SD5.6.1. See Figure SD5.2.

SD5.4.4 The flexible cord of each attachment plug assembly is to be fastened to the clamping mechanism shown in Figure SD5.3 or an equivalent mechanism that provides for the connection to the test set up shown in Figure SD5.2.

SD5.4.5 The receptacle outlets conditioned as described in SD5.4.2 and subsequently mounted as described in SD5.4.3 are then to be used to subject the attachment plug to the abrupt removals specified in SD5.5.1 or SD5.6.1, as applicable. Each abrupt removal is to consist of the full insertion of the attachment plug followed by the complete withdrawal by means of a 10 lb (4.4 kg) weight dropped from a height of 24 inches (0.61 m) - measured from the bottom of the weight - onto a striker plate attached to the plug by a 1/4 inch (6.4 mm) diameter guide rod and a flexible coupling. The guide rod shall be located as shown in Figure SD5.2. The applied force shall cause the removal of the test plug in one continuous motion.

#### **SD5.5 Straight attachment plugs**

SD5.5.1 The abrupt removal procedure for straight plugs is as follows: one removal with the grounding pin opening to the top of the vertically-oriented receptacle slots, then three additional removals rotating the receptacle 90 degrees clockwise before each additional plug removal. A total of eight devices is therefore required (four to be tested with each of the two receptacle types mentioned in SD5.4.1).

#### **SD5.6 Angle attachment plugs**

SD5.6.1 The abrupt removal procedure for angle plugs is as follows: four separate removals are required in each of two receptacle positions. First, the receptacle is to be positioned with the grounding pin opening to the top of the vertically-oriented slots. The first plug removal is to be with the direction of cord exit from the attachment plug to the top, then three additional removals are to be performed using devices whose cover has been rotated 90, 180, and 270 degrees from the original position. Four similar removals are then to be done with the receptacle positioned so that the grounding pin hole is to the right of the horizontally-oriented slots (first plug tested with cord exit to the top to be followed by plug removals with the cord exit at 90, 180, and 270 degrees from the original position). A total of 16 devices is therefore required (8 to be tested with each of the two receptacle types mentioned in SD5.4.1).

Figure SD5.2  
Test set-up for abrupt removals test

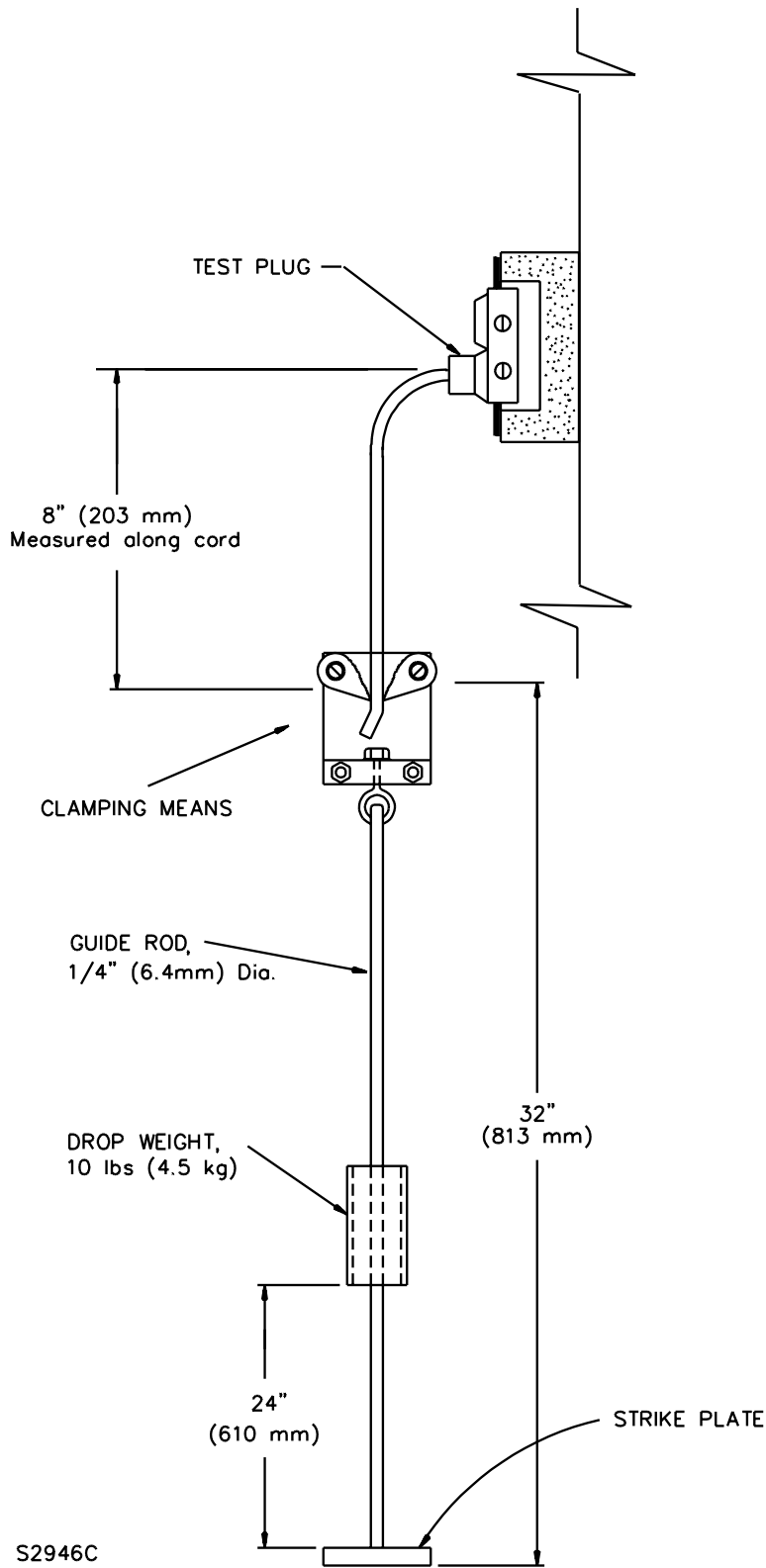

UL COPYRIGHTED MATERIAL –  
NOT AUTHORIZED FOR FURTHER REPRODUCTION OR  
DISTRIBUTION WITHOUT PERMISSION FROM UL

Figure SD5.3  
Typical clamping mechanism

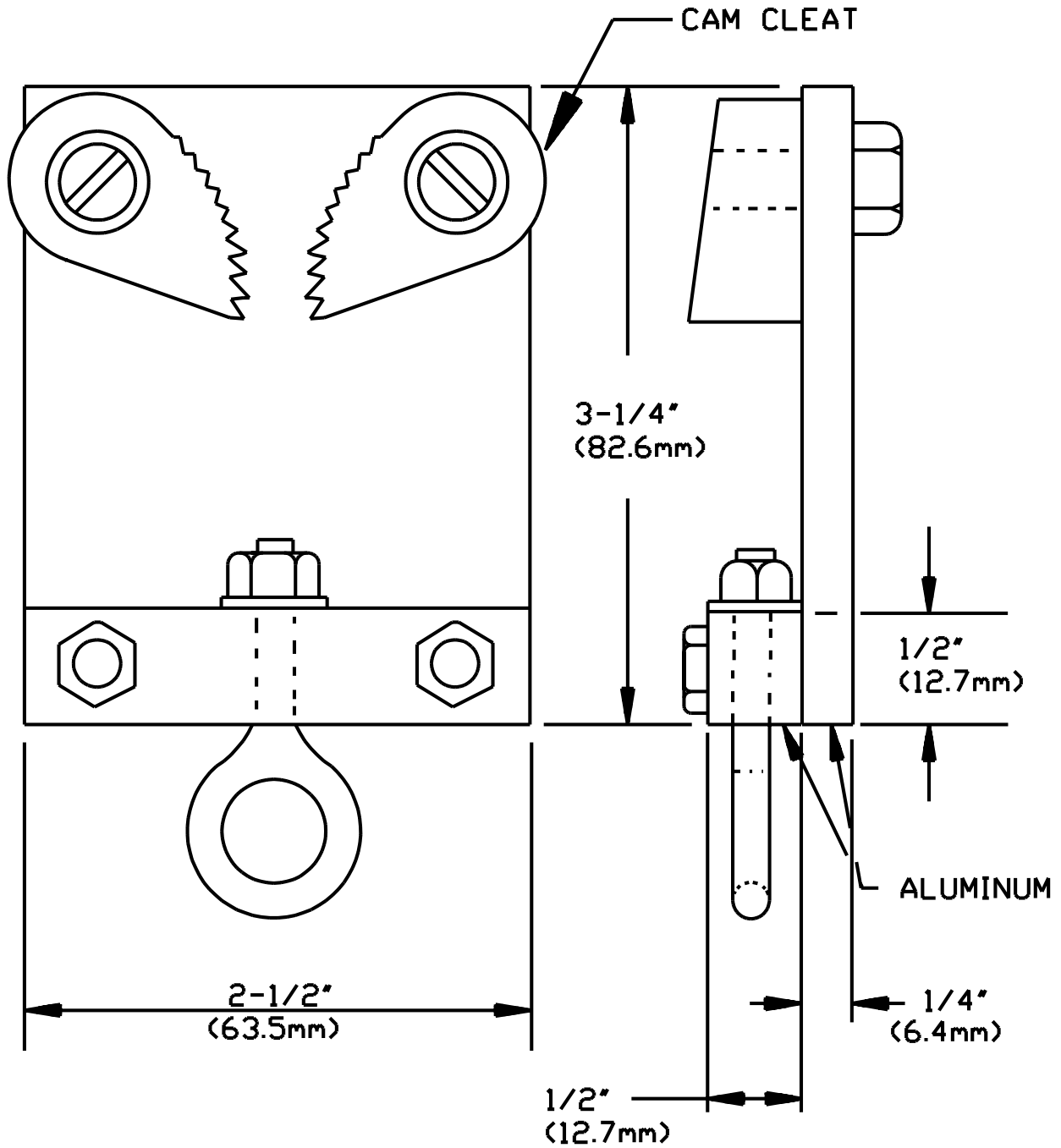

S2947

UL COPYRIGHTED MATERIAL –  
NOT AUTHORIZED FOR FURTHER REPRODUCTION OR  
DISTRIBUTION WITHOUT PERMISSION FROM UL

**SD6 Crushing Test**

SD6.1 An attachment plug shall be capable of withstanding the crushing test without resulting in breakage, deformation, or other adverse effects that may interfere with the intended function of the device.

SD6.2 Each of six devices wired onto flexible cord is to be placed between rigid horizontal steel plates. A crushing force is to be applied, increased gradually to a value of 500 lbf (2224 N). The force is then gradually removed. Each assembly is to be oriented in a natural resting position before applying the force. In no case is the force to be applied to the projecting blades.

SD6.3 The flexible cord used to wire the attachment plugs is to be the minimum size and type of flexible cord specified for use by the manufacturer in accordance with Reference No. 4 of Table 163.1.

**SD7 Impact Resistance Test**

SD7.1 As a result of the impact resistance test there shall not be any breakage of the body or other damage that may adversely affect the function of an attachment plug.

SD7.2 Each of the devices wired onto flexible cord is to be subjected to an impact caused by dropping a cylindrical 10 lb (4.5 kg) weight, having a flat face that is 2 inches (50.8 mm) in diameter, from a height of 18 inches (457 mm). Each assembly is to be placed on a hardwood surface in any natural resting position. A cylindrical attachment plug is to have its major axis parallel to the surface. The hardwood surface is to be a maple block approximately 1-5/8 inches (42 mm) thick by 4-1/2 inches (114 mm) square and is to rest on a fixed surface such as a concrete floor.

SD7.3 The flexible cord used to wire the attachment plugs is to be the minimum size and type of flexible cord specified for use by the manufacturer in accordance with Reference No. 4 of Table 163.1.

**SD8 Mechanical Drop Test**

SD8.1 Following the mechanical drop test:

- a) There shall not be any chipping, breaking, or loosening of parts that could adversely affect the functioning of the device, and
- b) The attachment plug shall be capable of withstanding the dielectric voltage-withstand test in SD8.4.



Figure SD8.1  
Mechanical drop test apparatus  
(All dimensions in inches)

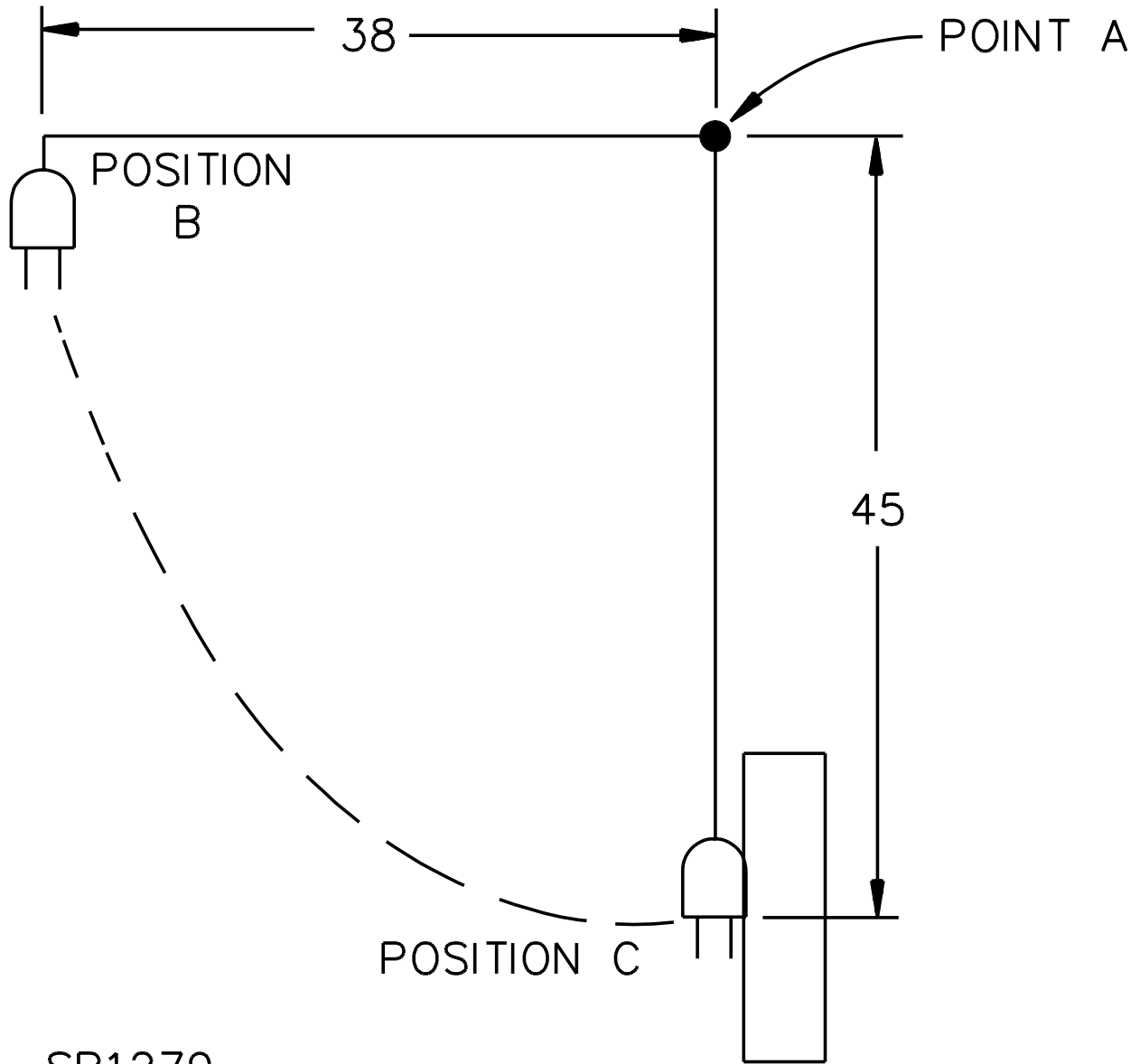

SB1279

inch	38	45
m	0.96	1.14

UL COPYRIGHTED MATERIAL –  
NOT AUTHORIZED FOR FURTHER REPRODUCTION OR  
DISTRIBUTION WITHOUT PERMISSION FROM UL

SD8.2 Each of the devices is to be assembled onto 18 AWG (0.8 mm<sup>2</sup>) flexible cord of a length sufficient for mounting on the test apparatus shown in Figure SD8.1. A 0.250 inch diameter (6.35 mm) braided nylon rope or its equivalent may be used to facilitate handling by the apparatus. The cord and attachment plug assembly is to be supported at point A so that when hanging freely the attachment plug rests against the vertical maple block 45 inches (1.14 m) below point A. A moving member of the test apparatus is to lift the test assembly to the test position B shown in Figure SD8.1 and then release it causing the plug to fall freely and strike the impact block at point C.

SD8.2 revised November 16, 2007

SD8.3 Each device is to be tested for not more than 1300 cycles. Each device is to complete not less than 500 cycles, and the average of the number of cycles completed by all devices is to be not less than 1000 cycles. Devices are to be inspected every 50 cycles beginning with the completion of 450 cycles. Assembly screws may be tightened throughout the test every 200 cycles.

SD8.4 The mechanical drop testing in SD8.2 and SD8.3 is to be followed by a dielectric voltage-withstand test of two times the plug rating plus 1000 V, applied between live parts of opposite polarity and between live parts and grounded metal parts for a period of 1 minute.

### **SD9 Mold Stress Relief Test**

SD9.1 As a result of temperature conditioning, there shall not be a change in any dimension greater than 10 percent nor any warpage creating an opening greater than 1/32 inch (0.79 mm) in any butt joint forming the enclosure of each attachment plug. Each attachment plug shall remain capable of functioning as intended.

SD9.2 The unwired attachment plugs are to be placed in a circulating air oven for 7 hours at 70°C (158°F). The devices are to be removed from the oven and allowed to cool to room temperature before determining compliance.

### **HOSPITAL GRADE CORD CONNECTORS**

#### **SD10 General**

SD10.1 Unless otherwise stated, previously untested cord connectors are to be used for each test.

**SD11 Grounding Contact Temperature Test**

SD11.1 The acceptability of the grounding path in a cord connector shall be demonstrated by a temperature rise not exceeding 30°C (54°F) when subjected to the test described in this section.

SD11.2 For the grounding contact temperature test, the previously untested cord connectors are first to be conditioned by 10 cycles of insertion and withdrawal from a solid-blade, 2-pole, 3-wire attachment plug having rigidly mounted blades and a U-shaped grounding pin. The abrupt removal test is not required on cord connectors.

SD11.3 The devices are to be wired in a series circuit through the grounding conductor path of the tested outlet of each device and a mating Hospital Grade plug. The test current is to be 25 A (125 percent of the maximum branch-circuit rating to which a 15 or 20 A receptacle could be connected). The cord connectors are to be wired using 12 AWG (3.3 mm<sup>2</sup>) flexible cord. Temperatures are to be measured after 1 hour on the grounding pin close to the face of the inserted plug. The current is then to be reduced to 22 A (110 percent of the maximum branch circuit rating) and the test continued until thermal equilibrium is reached. The temperature rise over room ambient shall not exceed 30°C (54°F) at any time.

SD11.3 revised November 16, 2007

No Text on This Page

Document Was Downloaded By jianxiong chen For Use By KAI HUA (FOSHAN SHUNDE) ELECTRIC APPLIANCE CO LTD 22381 : 5/8/2008 - 10:34 AM

***UL COPYRIGHTED MATERIAL –  
NOT AUTHORIZED FOR FURTHER REPRODUCTION OR  
DISTRIBUTION WITHOUT PERMISSION FROM UL***

**SD12 Resistance Test**

SD12.1 The total resistance between the mated attachment plug grounding terminal and cord connector grounding terminal shall not exceed 0.01 ohms when tested as follows.

SD12.2 The devices previously subjected to the Grounding Contact Temperature Test, Section SD11, are to be used for this test.

SD12.3 Compliance with SD12.1 is to be determined by passing an alternating current of 22 A from a power supply of 12 V or less from the attachment plug grounding terminal to the cord connector grounding terminal. The resulting drop in potential is to be measured between these two points. The resistance in ohms is to be determined by dividing the drop in potential in volts by the current in amperes passing between the two points.

**SD13 Grounding Contact Overstress Test**

SD13.1 A cord connector shall be capable of retaining the standard test pin shown in Figure SD13.1 for at least 1 minute following the conditioning described in SD13.2. The displacement of the test pin shall not be greater than 0.079 inch (2 mm). There shall not be any breakage that adversely affects the integrity of the enclosure of live parts.

SD13.2 Each outlet of six untested devices is to be conditioned then tested. The grounding contact of each outlet is to be conditioned by 20 insertions and withdrawals of the test pin illustrated in Figure SD13.2. For testing, the test pin illustrated in Figure SD13.1 is to be fully inserted in the receptacle which has its face horizontal so that the weight, applied perpendicular to the face, tends to withdraw the pin.

Figure SD13.1  
Standard grounding pin

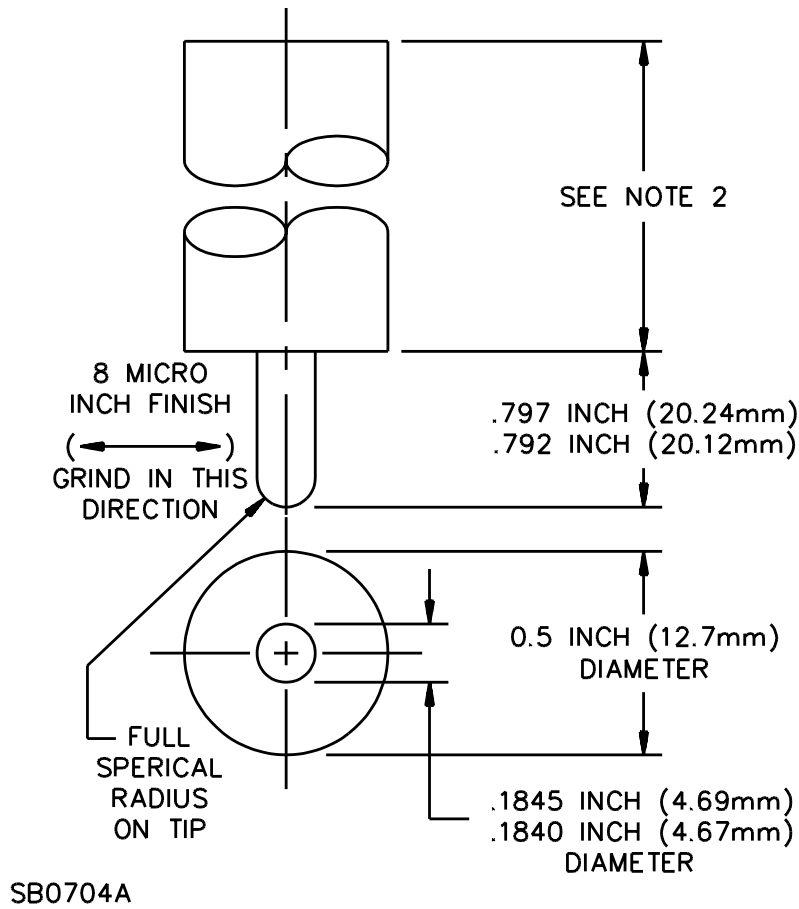

NOTES

- 1) All dimensions in inches.
- 2) Length not specified.
- 3) Total tool weight of 4 oz (113 g).
- 4) Hardened steel pin.

	0.1845		0.797
inch	0.1840	0.5	0.792
mm	4.686	13	20.24
	4.674		20.12
microinch		8	
nanometer		200	

UL COPYRIGHTED MATERIAL –  
NOT AUTHORIZED FOR FURTHER REPRODUCTION OR  
DISTRIBUTION WITHOUT PERMISSION FROM UL

Figure SD13.2  
Oversize grounding pin

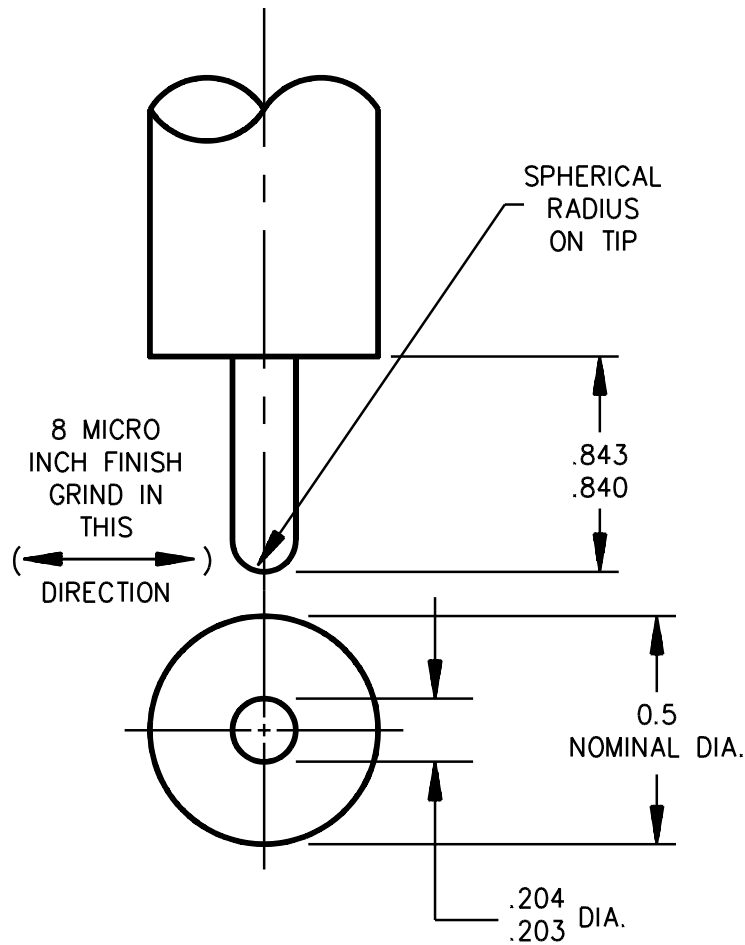

SB0705

NOTES

- 1) All dimensions in inches.
- 2) Length not specified for tool handle.
- 3) Hardened steel pin.

	0.204		0.843
inch	0.203	0.5	0.840
mm	5.18	13	21.41
	5.16		21.34
microinch		8	
nanometer		200	

UL COPYRIGHTED MATERIAL –  
NOT AUTHORIZED FOR FURTHER REPRODUCTION OR  
DISTRIBUTION WITHOUT PERMISSION FROM UL

## SD14 Plug Connection and Separation Test

SD14.1 Following the program of severe manual forces applied during the connection and separation of these devices described in this section, a cord connector shall:

- a) Maintain the grounding path integrity through the cord connector and the integrity of the cord connector insulating enclosure, and
- b) Have each outlet capable of retaining the test pin illustrated in Figure SD13.1. The displacement of the test pin shall not be greater than 0.079 inch (2 mm).

SD14.2 Each of six devices previously subjected to the grounding contact overstress test is to be tested by the insertion of a Hospital Grade attachment plug from the maximum angle permitted by the slots so as to maximize the grounding contact stress. The fully inserted plug is then to be firmly grasped in one hand and the cord connector in the other in preparation for the separations described below. Each device is to be subjected to a total of nine connections and separations as follows:

- a) The first three separations are to be subjected to a severe wiggling from side to side and twisting in such a manner that the cord connector is rotated in a direction opposite to the rotation of the attachment plug during the withdrawal,
- b) The next three separations are to be subjected to a severe breaking action in one direction in such a manner that the grounding pin of the mated attachment plug applies a force tending to deform the grounding contact construction in the cord connector, and
- c) The final three separations are to be subjected to a severe breaking action in the opposite direction.

SD14.3 After the separation conditioning, the test pin shown in Figure SD13.1 is to be inserted in the grounding contact with the force of the weight applied in a direction perpendicular to the face of the cord connector and tending to withdraw the pin from the device.

## SD15 Crushing Test

SD15.1 A cord connector shall be capable of withstanding the crushing test without resulting in breakage, deformation, or other adverse effects that may interfere with the intended function of the device.

SD15.2 Each of six devices wired onto flexible cord is to be placed between rigid horizontal steel plates. A crushing force is to be applied, increased gradually to a value of 500 lbf (2224 N). The force is then gradually removed. Each assembly is to be oriented in a natural resting position before applying the force. In no case is the force to be applied to the projecting blades.

SD15.3 The flexible cord used to wire the cord connector is to be the minimum size and type of flexible cord specified for use by the manufacturer in accordance with Reference No. 13 of Table 163.3.



**SD16 Impact Resistance Test**

SD16.1 As a result of the impact resistance test there shall not be any breakage of the body or other damage that may adversely affect the function of a cord connector.

SD16.2 Each of the devices wired onto flexible cord is to be subjected to an impact caused by dropping a cylindrical 10 lb (4.5 kg) weight, having a flat face that is 2 inches (50.8 mm) in diameter, from a height of 18 inches (457 mm). Each assembly is to be placed on a hardwood surface in any natural resting position. A cylindrical cord connector is to have its major axis parallel to the surface. The hardwood surface is to be a maple block approximately 1-5/8 inches (42 mm) thick by 4-1/2 inches (114 mm) square and is to rest on a fixed surface such as a concrete floor.

SD16.3 The flexible cord used to wire the cord connector is to be the minimum size and type of flexible cord specified for use by the manufacturer in accordance with Reference No. 5 of Table 163.3.

**SD17 Mechanical Drop Test**

SD17.1 Following the mechanical drop test:

- a) There shall not be any chipping, breaking, or loosening of parts that could adversely affect the functioning of the device, and
- b) The cord connector shall be capable of withstanding the dielectric voltage-withstand test in SD17.4.

SD17.2 Each of the devices is to be assembled onto 18 AWG (0.82 mm<sup>2</sup>) flexible cord of a length sufficient for mounting on the test apparatus shown in Figure SD17.1. A 0.250 inch diameter (6.35 mm) braided nylon rope or its equivalent may be used to facilitate handling by the apparatus. The cord and attachment plug assembly is to be supported at point A so that when hanging freely the attachment plug rests against the vertical maple block 45 inches (1.14 m) below point A. A moving member of the test apparatus is to lift the test assembly to the test position B shown in Figure SD17.1 and then release it causing the plug to fall freely and strike the impact block at point C.

SD17.2 revised November 16, 2007

Figure SD17.1  
Mechanical drop test apparatus  
(All dimensions in inches)

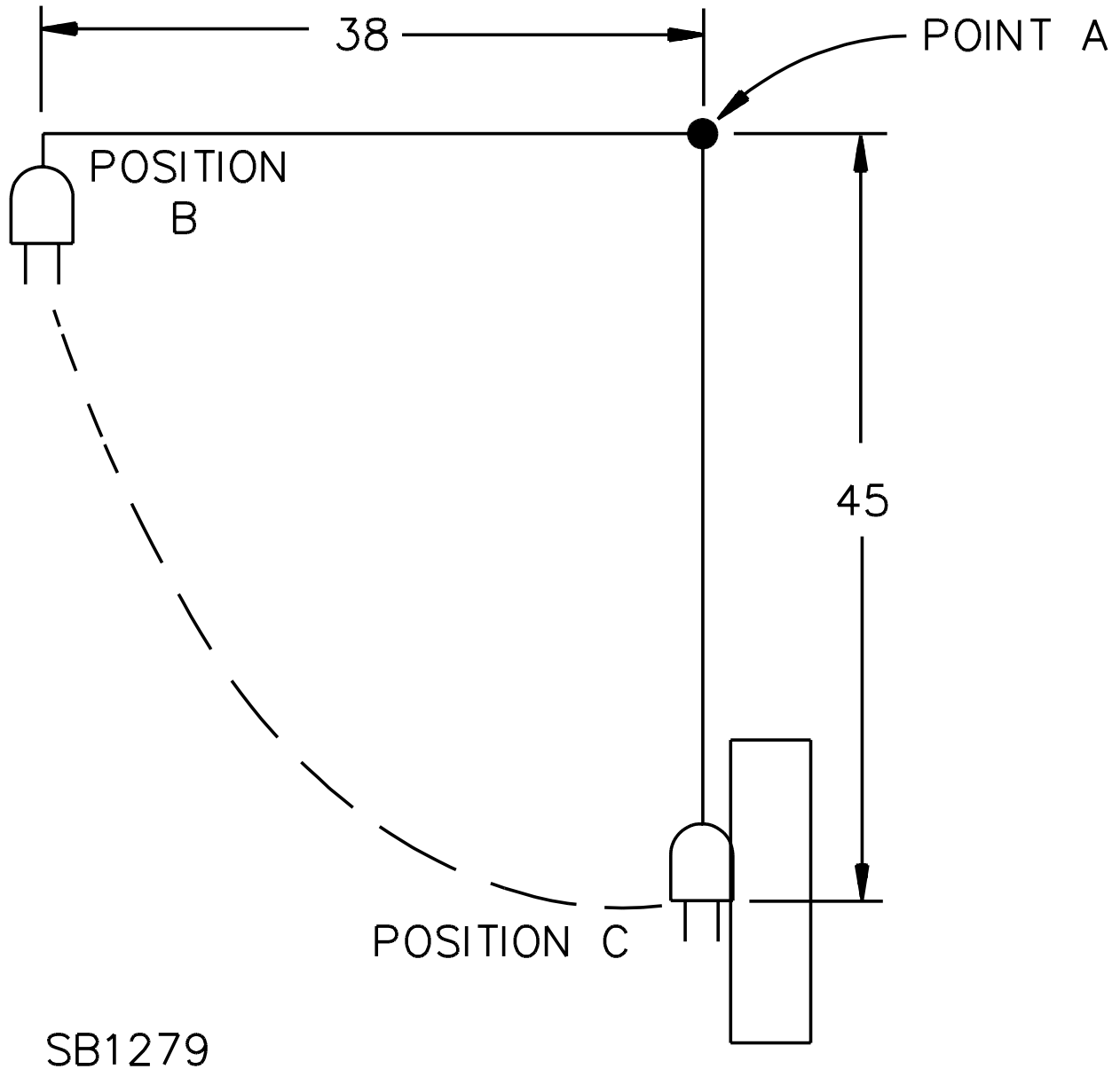

inch	38	45
m	0.96	1.14

UL COPYRIGHTED MATERIAL –  
NOT AUTHORIZED FOR FURTHER REPRODUCTION OR  
DISTRIBUTION WITHOUT PERMISSION FROM UL

SD17.3 Each device is to be tested for not more than 1300 cycles. Each device is to complete not less than 500 cycles, and the average of the number of cycles completed by all devices is to be not less than 1000 cycles. Devices are to be inspected every 50 cycles beginning with the completion of 450 cycles. Assembly screws may be tightened throughout the test every 200 cycles.

SD17.4 The mechanical drop testing in SD17.2 and SD17.3 is to be followed by a dielectric voltage-withstand test of two times the connector rating plus 1000 V, applied between live parts of opposite polarity and between live parts and grounded metal parts for a period of 1 minute.

### **SD18 Mold Stress Relief Test**

SD18.1 As a result of temperature conditioning, there shall not be a change in any dimension greater than 10 percent nor any warpage creating an opening greater than 1/32 inch (0.79 mm) in any butt joint forming the enclosure of each cord connector. Each cord connector shall remain capable of functioning as intended.

SD18.2 The unwired cord connectors are to be placed in a circulating air oven for 7 hours at 70°C (158°F). The devices are to be removed from the oven and allowed to cool to room temperature before determining compliance.

### **SD19 Strain Relief Tests**

#### **SD19.1 General**

SD19.1.1 A cord connector shall withstand the strain relief tests described in this Section. Fifteen devices are necessary to accomplish strain-relief testing.

*Exception: A cord connector that employs the same construction as a Hospital Grade attachment plug is not required to be subjected to strain relief testing.*

SD19.1.2 After being subjected to the strain relief tests described in this section, there shall not be any displacement of the conductors, conductor insulation, or outer jacket of the flexible cord exceeding 1/32 inch (0.79 mm). There shall not be any cuts, rips, or tears in the cord insulation nor any breakage of the cord connector that could adversely affect the enclosure of live parts, strain relief, or grounding path integrity.

SD19.1.3 Cord connectors are to be assembled onto 12 inch (305 mm) lengths of flexible cord 24 hours before testing. The flexible cord is to be cut at right angles to its major axis (but not stripped) and placed in the plug with its conductors positioned as if they were to be connected to the terminals. A 20 A cord connector is to be assembled onto 16 AWG (1.3 mm<sup>2</sup>), Type SJT cord. A 15 A connector is to be assembled onto 18 AWG (0.82 mm<sup>2</sup>), Type SVT cord except where the device is marked on or in the carton to specifically exclude the use of cords having a diameter of less than 0.300 inch (7.62 mm) in which case Type SJT cord having 18 AWG (0.82 mm<sup>2</sup>) conductors is to be used. Except for a device that is individually packaged with instructions for cord clamp installation indicating the torsional force to be applied, the clamp is to be tightened with a torque of 8 in-lbf (0.9 N·m).

SD19.1.3 revised November 16, 2007

**UL COPYRIGHTED MATERIAL –  
NOT AUTHORIZED FOR FURTHER REPRODUCTION OR  
DISTRIBUTION WITHOUT PERMISSION FROM UL**

### SD19.2 Method A – static pull

SD19.2.1 Each of six devices previously assembled onto flexible cord is to be subjected to a gradually applied pull of 30 lbf (133 N) to the free end of the cord while supporting the cord connector. The force is to be applied for 1 minute in a direction perpendicular to the plane of cord entry.

### SD19.3 Method B – rotary pull

SD19.3.1 Each of three devices previously assembled onto flexible cord is to be subjected to a rotary cord motion while a 10 lbf (44.5 N) is applied for 2 hours. The cord is to be rotated at a rate of approximately 9 rpm in a 3 inch diameter (0.76 mm) circle at a point of 6 inches (152 mm) below the cord exit with the attachment plug rigidly mounted. (Note – This test is conveniently done with the UL secureness test apparatus described in the Standard for Wire Connectors, UL 486A-486B.)

SD19.3.1 revised November 16, 2007

### SD19.4 Method C – abrupt removal

SD19.4.1 Each of eight previously untested cord connectors assembled onto flexible cord as described in SD19.1.3 is to be subjected to one abrupt removal from a Hospital Grade attachment plug as described in this section.

SD19.4.1 revised November 16, 2007

SD19.4.2 Each Hospital Grade attachment plug is to be rigidly mounted to a fixed support with its face at a 60 degree angle from the vertical as shown in Figure SD19.1.

SD19.4.3 The flexible cord of each cord connector assembly is to be fastened to the clamping mechanism shown in Figure SD19.2 or an equivalent mechanism that provides for the connection to the test set up described in Figure SD19.1.

SD19.4.4 The Hospital Grade attachment plug mounted as described in SD19.4.2 is then to be used to subject the cord connectors to the abrupt removals specified in SD19.4.5. Each abrupt removal is to consist of the full insertion of the cord connector onto the test plug followed by the complete withdrawal by means of a 10 lb (4.4 kg) weight dropped from a height of 24 inches (0.61 m) - measured from the bottom of the weight - onto a striker plate attached to the plug by a 1/4 inch (6.4 mm) diameter guide rod and a flexible coupling. The guide rod shall be located as shown in Figure SD19.1. The applied force shall cause the removal from the test plug in one continuous motion. A new test plug is to be used for each abrupt removal.

SD19.4.5 The abrupt removal procedure for cord connectors is as follows: one removal with the grounding pin opening to the top of the vertically-oriented line blades, then three additional removals rotating the plug 90 degrees clockwise before each additional cord connector removal.

Figure SD19.1  
Test set-up for abrupt removals test

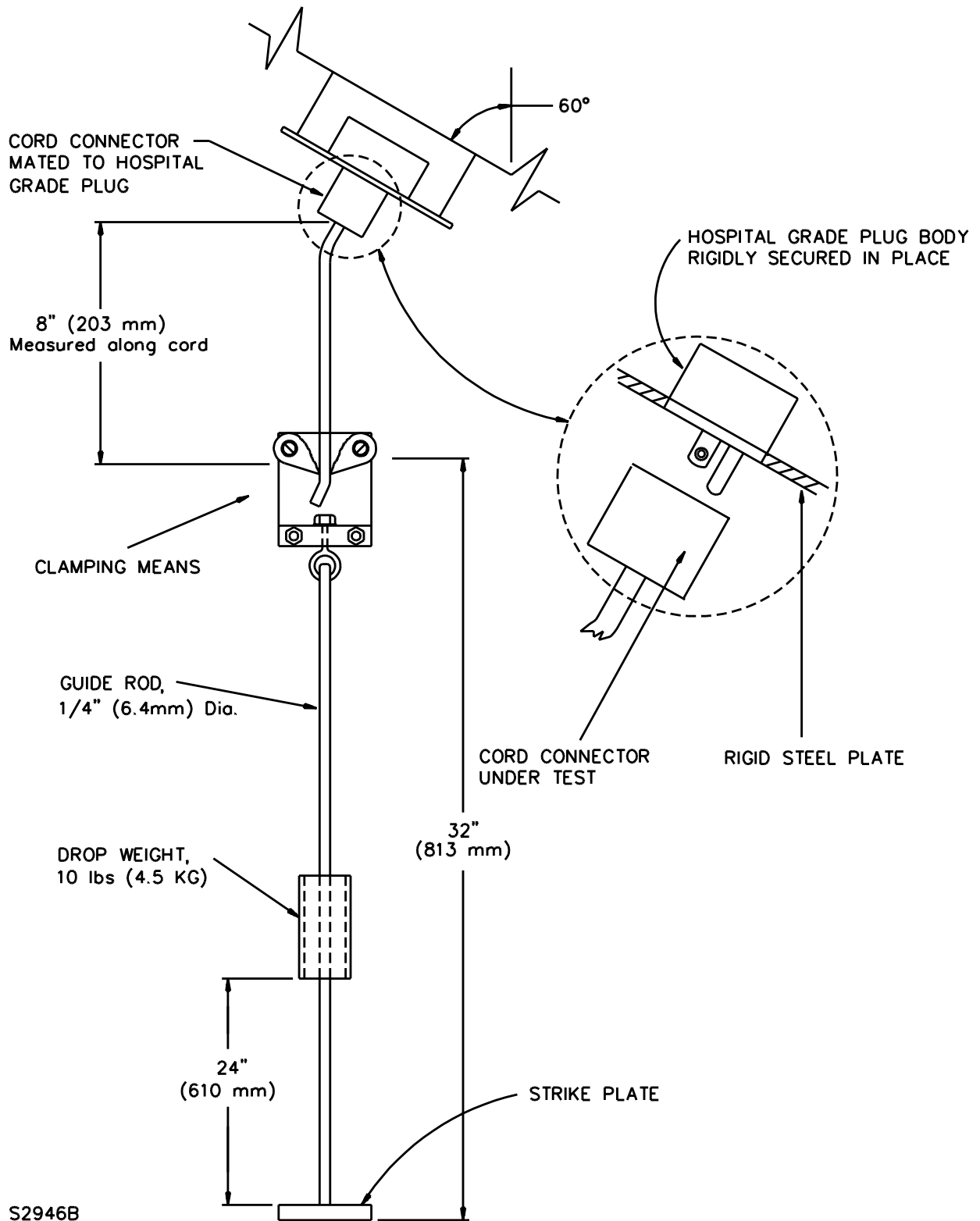

S2946B

UL COPYRIGHTED MATERIAL –  
NOT AUTHORIZED FOR FURTHER REPRODUCTION OR  
DISTRIBUTION WITHOUT PERMISSION FROM UL

Figure SD19.2  
Typical clamping mechanism

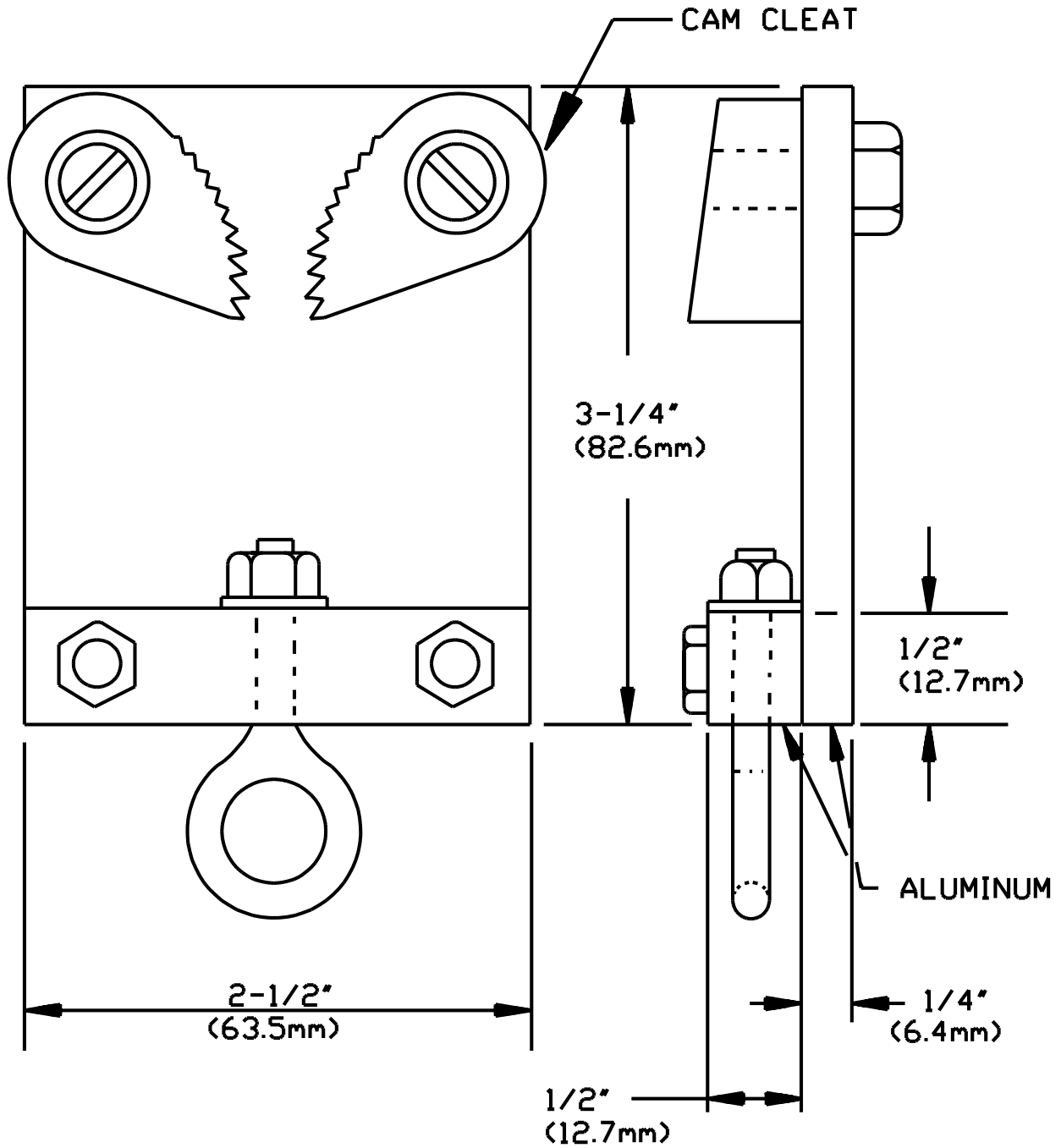

S2947

UL COPYRIGHTED MATERIAL –  
NOT AUTHORIZED FOR FURTHER REPRODUCTION OR  
DISTRIBUTION WITHOUT PERMISSION FROM UL

## HOSPITAL GRADE RECEPTACLES

### SD20 General

SD20.1 Unless otherwise stated, previously untested devices are to be used for each test.

SD20.2 The Hospital Grade attachment plugs required to perform the tests in Grounding Contact Temperature Test, Section SD22, Resistance Test, Section SD23, and Fault Current Test, Section SD24, shall have a U-shaped grounding pin.

### SD21 Abrupt Plug Removal Test

SD21.1 A receptacle shall retain the test pin illustrated in Figure SD21.1 without breakage or other damage such that full insertion of an attachment plug in the intended manner cannot be accomplished or the integrity of the enclosure of live parts is adversely affected when tested as described in this section.

SD21.2 Each receptacle outlet is to be first conditioned by ten cycles of full insertion and complete withdrawal of an attachment plug of the matching configuration having solid line blades and a U-shaped ground pin rigidly supported by the attachment plug body. Each conditioned outlet is then to retain the fully inserted test pin illustrated in Figure SD21.1 for not less than 1 minute with the receptacle face horizontal and the weight applied perpendicular to the face plane, tending to remove the pin. The displacement of the test pin shall not be greater than 0.079 inch (2 mm).

Figure SD21.1  
Standard grounding pin

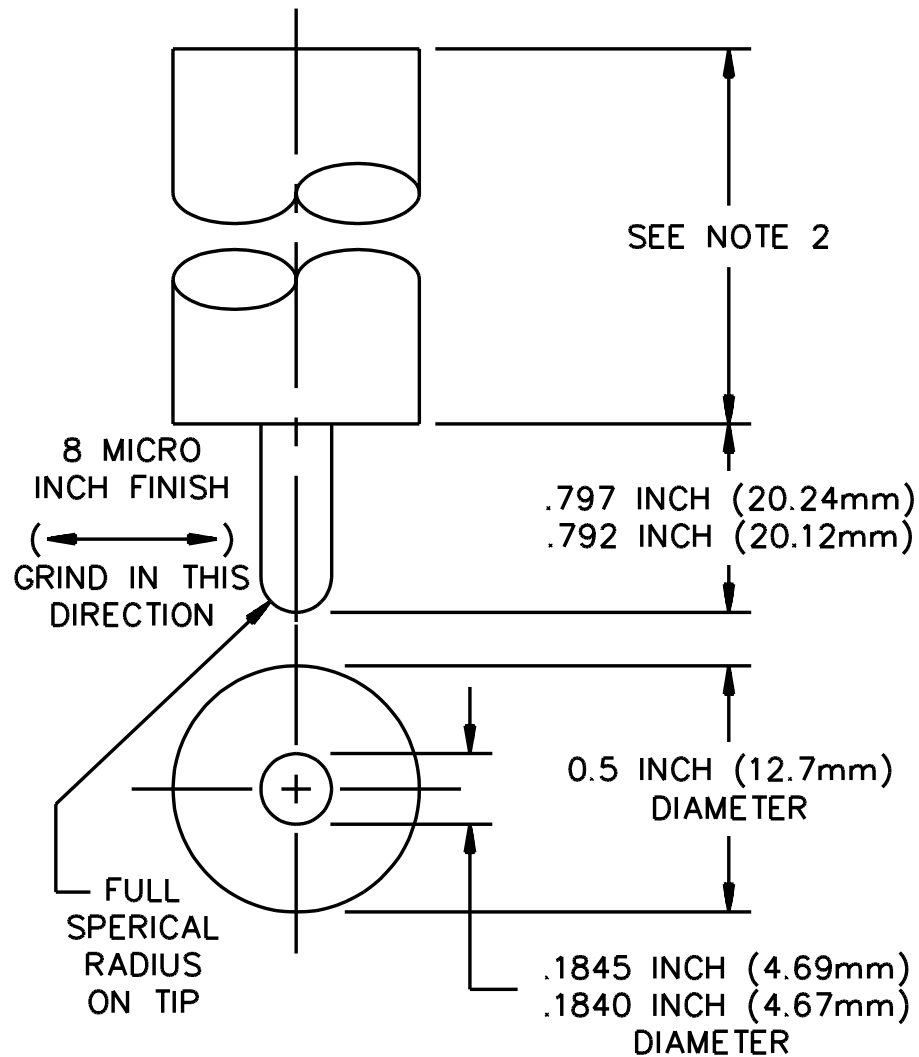

SB0704A

NOTES

- 1) All dimensions in inches.
- 2) Length not specified
- 3) Total tool weight of 4 oz (113 g).
- 4) Hardened steel pin.

microinch  
nanometer

8  
200

UL COPYRIGHTED MATERIAL –  
NOT AUTHORIZED FOR FURTHER REPRODUCTION OR  
DISTRIBUTION WITHOUT PERMISSION FROM UL



SD21.3 Each receptacle is then to be mounted to represent a typical installation and a 0.030 plus 0.003 minus 0.0 inch (0.76 plus 0.08 minus 0.0 mm) steel faceplate rigidly mounted as intended, being supported around its perimeter. The receptacle face is to be in a vertical plane in a manner that will facilitate the test orientations described in SD21.5 and SD21.6.

SD21.4 The outlets tested as described in SD21.2 and subsequently mounted as described in SD21.3 are to then each be subjected to a series of abrupt removals of the test plug illustrated in Figure SD21.2 as follows. Each abrupt removal is to consist of the full insertion of the test plug followed by the complete withdrawal by means of a 10 lb (4.4 kg) weight dropped from a height of 24 inches (0.61 m) - measured from the bottom of the weight - onto a striker plate attached to the plug by a 1/4 inch (6.4 mm) diameter guide rod and a flexible coupling. The guide rod shall be located vertically below the outlet being tested, and 2 inches (50.8 mm) in front of the plane of the receptacle face (see Figure SD21.3). The applied force shall cause the removal of the test plug in one continuous motion. New blades are to be used in the test plug for each abrupt removal.

**UL COPYRIGHTED MATERIAL –  
NOT AUTHORIZED FOR FURTHER REPRODUCTION OR  
DISTRIBUTION WITHOUT PERMISSION FROM UL**

Figure SD21.2  
Typical test plug for abrupt plug removals

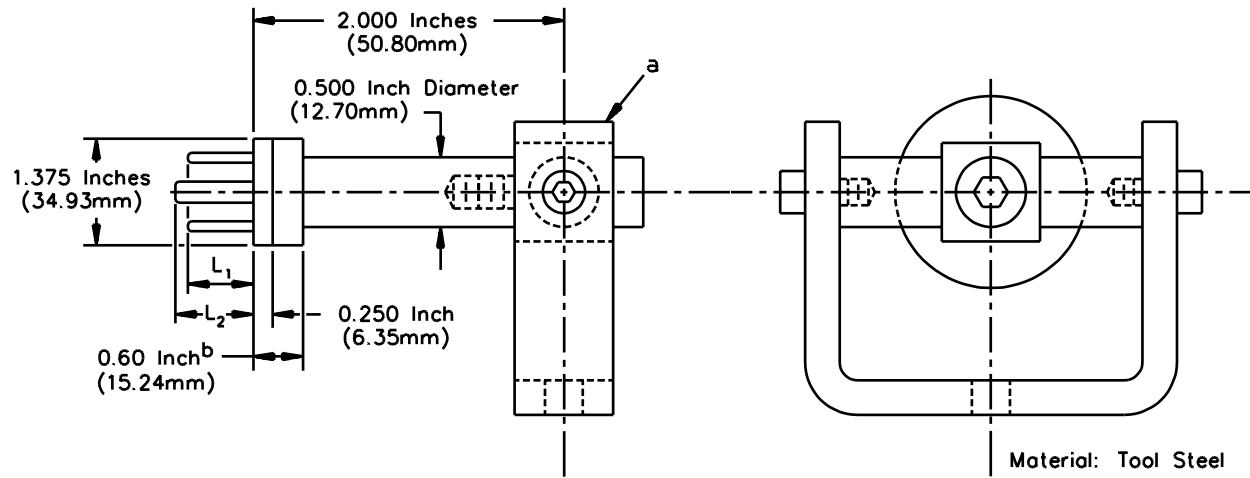

NOTES:

- a - Universal coupling, details not specified, typical application shown
- b - Dimensions are for typical construction and can be varied, provided that the necessary support of the test blades is maintained
- $L_1 = 0.625$  Inch (15.88 mm) Max.
- $L_2 = 0.843$  Inch (21.41 mm) Max.
- $L_2 - L_1 = 0.125$  Inch (3.18 mm) Min.

S2069A

UL COPYRIGHTED MATERIAL –  
NOT AUTHORIZED FOR FURTHER REPRODUCTION OR  
DISTRIBUTION WITHOUT PERMISSION FROM UL

Figure SD21.3  
Test set-up for abrupt removals test

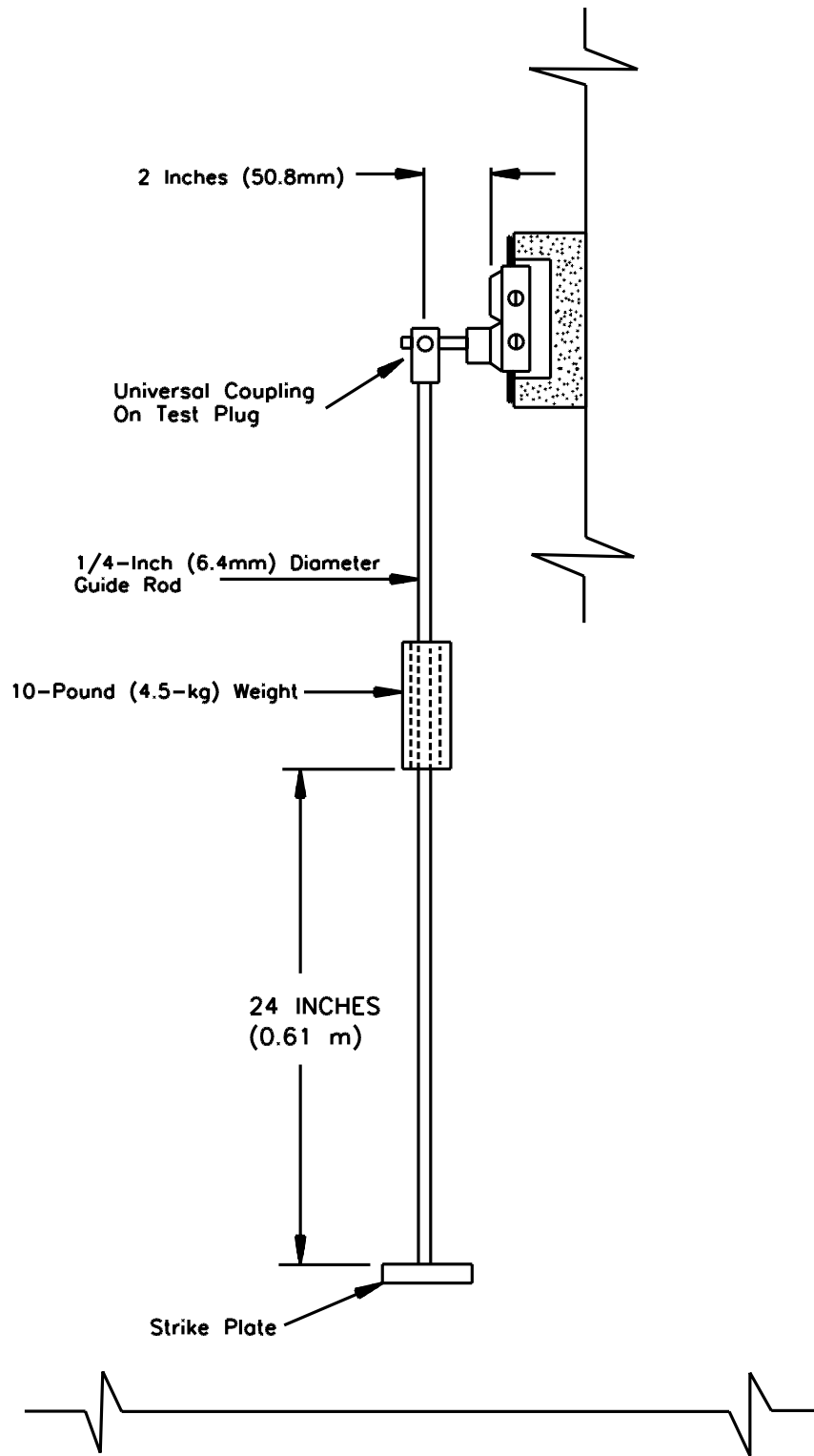

S2068

UL COPYRIGHTED MATERIAL –  
NOT AUTHORIZED FOR FURTHER REPRODUCTION OR  
DISTRIBUTION WITHOUT PERMISSION FROM UL

SD21.5 Four devices are to be tested as follows: two removals with the grounding pin opening to the top of the vertically-oriented slots, then four removals with the receptacle rotated 180 degrees, then two more removals in the initial position.

SD21.6 The remaining four devices are to be tested as follows: two removals with the grounding pin opening to the right of the horizontally oriented slots, then four removals with the receptacle rotated 180 degrees, then two more removals in the initial position.

SD21.7 Duplex receptacles are to be tested by using one of the two outlets for one half of the devices and the other outlet for the remaining devices.

SD21.8 Receptacles rated 20 A that accept 15 A attachment plugs are to be tested using one half of the devices for testing with the 20 A plug configuration and the remaining devices with the 15 A plug configuration.

SD21.9 After the conditioning described in SD21.2 and the abrupt plug removals described in SD21.4 – SD21.6, each outlet shall retain the fully inserted test pin illustrated in Figure SD21.1 for at least 1 minute. For this test, each receptacle is to be placed with its face horizontal so that the downward force exerted by the pin is perpendicular to the plane of the receptacle face and tends to withdraw the pin. The displacement of the test pin shall not be greater than 0.079 inch (2 mm).

SD21.10 In addition to retaining the fully inserted test pin as described in SD21.9, each receptacle outlet subjected to the tests described in this section shall:

- a) Be capable of receiving a fully inserted attachment plug (3-wire, solid blades with U-shaped grounding pin) of the intended configuration,
- b) Not experience any breakage or other damage that exposes live parts to contact with a probe consisting of a 1/32 inch (0.79 mm) diameter cylindrical rod, and
- c) Retain a fully inserted 2-wire attachment plug having a rigid body and solid blades without displacement resulting from the application of a 3 lbf (13.3 N) in a direction perpendicular to the receptacle outlet and tending to withdraw the plug, following which, there shall be electrical continuity through each blade/contact connection.

**SD22 Grounding Contact Temperature Test**

SD22.1 The acceptability of the grounding path in a receptacle shall be demonstrated by a temperature rise not exceeding 30°C (54°F) when subjected to the test described in this section.

SD22.2 The devices previously subjected to the Abrupt Plug Removal Test in Section SD21 are to be wired in a series circuit through the grounding conductor path of the tested outlet of each device and a mating Hospital Grade plug. The test current is to be 25 A (125 percent of the maximum branch-circuit rating to which a 15 or 20 A receptacle could be connected). Each receptacle is to be wired using 12 AWG (3.3 mm<sup>2</sup>) solid copper wire. Attachment plugs are to be wired using 12 AWG (3.3 mm<sup>2</sup>) flexible cord. Temperatures are to be measured after 1 hour on the grounding pin close to the face of the inserted plug. The current is then to be reduced to 22 A (110 percent of the maximum branch circuit rating) and the test continued until thermal equilibrium is reached. The temperature rise over room ambient shall not exceed 30°C (54°F) at any time.

SD22.2 revised November 16, 2007

**SD23 Resistance Test**

SD23.1 The total resistance between the mated attachment plug grounding terminal and receptacle grounding terminal shall not exceed 0.01 ohms when tested as follows.

SD23.2 The devices previously subjected to the Grounding Contact Temperature Test, Section SD22 are to be used for this test.

SD23.3 Compliance with SD23.1 is to be determined by passing an alternating current of 22 A from a power supply of 12 V or less from the attachment plug grounding terminal to the receptacle grounding terminal. The resulting drop in potential is to be measured between these two points. The resistance in ohms is to be determined by dividing the drop in potential in volts by the current in amperes passing between the two points.

**SD24 Fault Current Test**

SD24.1 When subjected to the Fault Current Test, the circuit breaker shall operate when the test circuit is closed. The grounding path shall retain its integrity as demonstrated by a continuity check after removing and reinserting the attachment plug.

SD24.2 The devices previously used for the Resistance Test, Section SD23, are to be subjected to the Fault Current Test described in Section 116.

## SD25 Grounding Contact Overstress Test

SD25.1 A receptacle is to be capable of retaining the standard test pin shown in Figure SD21.1 for at least 1 minute following the conditioning described in SD25.2. The displacement of the test pin shall not be greater than 0.079 inch (2 mm). There shall not be any breakage that adversely affects the integrity of the enclosure of live parts.

SD25.2 Each outlet of six untested devices is to be conditioned, then tested. The grounding contact of each outlet is to be conditioned by 20 insertions and withdrawals of the test pin illustrated in Figure SD25.1. For testing, the test pin is to be fully inserted in the receptacle which has its face horizontal so that the weight, applied perpendicular to the face, tends to withdraw the pin.

Figure SD25.1  
Oversize grounding pin

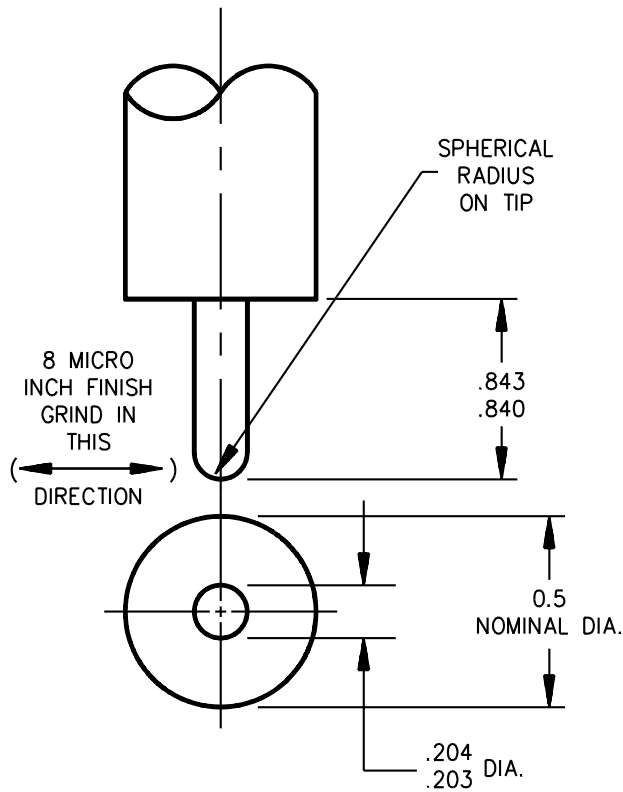

SB0705

NOTES

- 1) All dimensions in inches.
- 2) Length not specified for tool handle.
- 3) Hardened steel pin.
- 4) If the test pin is unable to be fully seated in the grounding contact, a similar test pin is to be used. All dimensions other than the 0.203 – 0.204 inch (5.16 – 5.18 mm) pin diameter are to be identical to the dimensions of the pin shown above. The pin diameter is to be the largest diameter that is able to be fully seated in the grounding contact with a minimum diameter of 0.190 inch (4.83 mm).

	0.204		0.843
inch	0.203	0.5	0.840
mm	5.18	13	21.41
	5.16		21.34
microinch		8	
nanometer		200	

UL COPYRIGHTED MATERIAL –  
NOT AUTHORIZED FOR FURTHER REPRODUCTION OR  
DISTRIBUTION WITHOUT PERMISSION FROM UL

**SD26 Terminal Strength Test**

SD26.1 The terminals of three untested receptacles are to be subjected to the Terminal Strength Test described in Section 117 with the modifications described in SD26.2.

SD26.2 The terminals are to be disassembled, assembled, and torqued three additional times following the method described in 117.5 except that the maximum tightening torque is to be 14 lbf-in (1.6 N·m).

**SD27 Assembly Security Test**

SD27.1 A Hospital Grade receptacle is to be subjected to the Assembly Security Test described in Section 118 except that the force exerted by the pushout tool inserted into the slots of the receptacle is to be 100 lbf (445 N).

**SD28 Impact Test**

SD28.1 A receptacle shall withstand the following impact test without experiencing breakage that impairs the function of the receptacle in enclosing and supporting contacting members for the connection of an attachment plug.

SD28.2 Six receptacles are to be mounted to a cast metal (malleable iron) outlet box and a metal faceplate installed as intended to provide peripheral support against the box edge. The receptacle, faceplate, and box are to be placed on a steel plate at least 1/2 inch (12.7 mm) thick with the outlet facing upward. A 5 lb (2.3 kg) cylindrical weight, 1-1/4 inch (31.8 mm) in diameter and having a flat end, is to be dropped from a height of 18 inches (0.46 m) to impact the center of each receptacle outlet. For duplex receptacles, three devices are to be tested using one outlet, and three using the other.

**SD29 Mold Stress Relief Test**

SD29.1 As a result of temperature conditioning, there shall not be a change in any dimension greater than 10 percent nor any warpage creating an opening greater than 1/32 inch (0.79 mm) in any butt joint forming the enclosure of each receptacle. Each device shall remain capable of functioning as intended.

SD29.2 The unwired receptacles are to be placed in a circulating air oven for 7 hours at 90°C (194°F). The devices are to be removed from the oven and allowed to cool to room temperature before determining compliance.



## MARKINGS

### SD30 General

SD30.1 An attachment plug or cord connector shall be marked with the phrase "Hospital Grade" or "Hosp. Grade" and with a green dot. The markings shall be located on any external surface including the face of the device so that it is visible after installation on flexible cord. The green dot shall not be located on an external (removable) strain relief clamp.

SD30.2 A receptacle shall be marked with the phrase "Hospital Grade" or "Hosp. Grade" where visible during installation and with a green dot that is visible after installation with the cover plate secured as intended.

SD30.3 The green dot shall be a contrasting shade of green if on a green-bodied device and shall be 3/16 inch (4.8 mm) minimum, 1/4 inch (6.4 mm) maximum in diameter.

SD30.4 The green dot shall be ink stamped, painted, or otherwise applied in a manner determined to be indelible. A label or sticker marked with the green dot and attached by an adhesive or other means to the device shall not be readily removable without destroying its significance if reapplied.

No Text on This Page

Document Was Downloaded By jianxiong chen For Use By KAI HUA (FOSHAN SHUNDE) ELECTRIC APPLIANCE CO LTD 22381 : 5/8/2008 - 10:34 AM

***UL COPYRIGHTED MATERIAL –  
NOT AUTHORIZED FOR FURTHER REPRODUCTION OR  
DISTRIBUTION WITHOUT PERMISSION FROM UL***

## SUPPLEMENT SE - WEATHER-RESISTANT RECEPTACLES

### INTRODUCTION

#### SE1 Scope

SE1.1 The requirements of this supplement cover weather-resistant flush-type receptacles, intended for wet and damp locations in accordance with Article 406 of the National Electrical Code, ANSI/NFPA-70.

SE1.1 added May 25, 2007

SE1.2 These requirements are applicable to flush-type, non-locking configuration devices of the ANSI/NEMA 5-15R, 6-15R, 5-20R, and 6-20R configurations only.

SE1.2 added May 25, 2007

SE1.3 Weather-resistant receptacles are intended only for flush installation in an appropriate enclosure suitable for the application.

SE1.3 added May 25, 2007

SE1.4 A weather-resistant receptacle shall comply with the applicable requirements of this standard, UL 498, except as modified by the requirements in this supplement.

SE1.4 added May 25, 2007

SE1.5 This supplement is intended to evaluate only the flush receptacle covered by this standard, UL 498.

SE1.5 added May 25, 2007

SE1.6 This supplement does not apply to the enclosure or any component which forms the enclosure, including the outlet box or flush-device cover plate, or both.

SE1.6 added May 25, 2007

SE1.7 This supplement does not apply to other end-product equipment that incorporate a weather-resistant receptacle.

SE1.7 added May 25, 2007

**UL COPYRIGHTED MATERIAL –  
NOT AUTHORIZED FOR FURTHER REPRODUCTION OR  
DISTRIBUTION WITHOUT PERMISSION FROM UL**

## CONSTRUCTION

### SE2 General

SE2.1 In addition to the general performance and construction requirements for receptacles, weather-resistant receptacles shall also comply with requirements for corrosion resistance, cold impact, accelerated aging, and resistance to ultraviolet light and water exposure, as specified in this supplement.

SE2.1 added May 25, 2007

### SE3 Insulating Materials

SE3.1 An insulating material used in the construction of the face of a weather-resistant receptacle shall comply with the Ultraviolet Light and Water Exposure Test in Section SE8.

*Exception: Insulating materials used in the construction of components other than the face of a weather-resistant receptacle, such as the body, shutters, and indicator lights, are not required to comply with this requirement. This exception does not apply to external shutters located on the outer face of the device.*

SE3.1 added May 25, 2007

### SE4 Corrosion Resistance

SE4.1 Except as noted in SE4.2, all current-carrying parts shall be copper alloy.

SE4.1 added May 25, 2007

SE4.2 All wire-binding screws and terminal pressure plates shall be copper alloy or stainless steel having a minimum of 16 percent chromium content. An internal backwire nut may be steel protected with nickel as described in SE4.4(a) (3) or (4). Protection is required on all sheared or cut edges but not required for punched holes with screw threads.

SE4.2 added May 25, 2007

SE4.3 Metals used in combinations shall be galvanically compatible.

SE4.3 added May 25, 2007

SE4.4 Noncurrent-carrying metal parts, such as metal mounting yoke, and mounting screws shall be:

a) Steel protected by one of the following coatings:

1) Hot-dipped mill-galvanized sheet steel conforming with the coating Designation A60, G60 or G90 in the Weight (Mass) of Coating Requirements table in the Standard Specification for Steel Sheet, Zinc-Coated (Galvanized) or Zinc-Iron Alloy-Coated (Galvannealed) by the Hot-Dip Process, ASTM A653, with not less than 40 percent of the zinc on any side, based on the minimum single-spot test requirement in this ASTM designation. The weight of the zinc coating may be determined by any acceptable method; however, in case of question the weight of coating shall be established in accordance with the Standard Test Method for Weight (Mass) of Coating on Iron or Steel Articles With Zinc or Zinc-Alloy Coatings, ASTM A90. Sheared, cut edges, punched holes and screw threads are not required to be additionally protected;

**UL COPYRIGHTED MATERIAL –  
NOT AUTHORIZED FOR FURTHER REPRODUCTION OR  
DISTRIBUTION WITHOUT PERMISSION FROM UL**

- 2) A zinc coating, other than that provided on hot-dipped mill-galvanized steel, having an average thickness not less than 0.0005 in (0.013 mm) or a thickness of less than 0.0004 in (0.0102 mm). Sheared, cut edges punched holes, and screw threads are not required to be additionally protected;
  - 3) A nickel coating having a thickness not less than 0.00015 in (0.0038 mm); or
  - 4) A tin over nickel coating having an overall thickness of not less than 0.00015 in (0.0038 mm).
- b) Stainless steel having a minimum of 16 percent chromium content; or
  - c) Copper, bronze or brass alloys.
  - d) Aluminum or aluminum alloys.

SE4.4 added May 25, 2007

## PERFORMANCE

### SE5 General

SE5.1 A weather-resistant receptacle shall be subjected to the Cold Impact Test, Section SE6, the Accelerated Aging Test, Section SE7, and the Ultraviolet Light and Water Exposure Test, Section SE8.

SE5.1 added May 25, 2007

### SE6 Cold Impact Test

SE6.1 When subjected to the Cold Impact Test described in SE6.2, six representative weather-resistant receptacles shall withstand the impact without breakage of the receptacle face or any other damage that could increase the risk of fire or electric shock. Upon completion of the test, each device shall be:

- a) Capable of completely mating with the intended attachment plugs both grounding and non-grounding types;
- b) Shall not crack to the extent such that a 1/32 in (0.8 mm) diameter rod can be inserted through the crack and contact live parts; and
- c) Subjected to the Dielectric Voltage-Withstand Test described in Section 60. The devices are not required to be subjected to the humidity conditioning described in 60.1.2.

SE6.1 added May 25, 2007

SE6.2 Six representative weather-resistant receptacles shall be conditioned for 5 h in circulating air at a temperature of minus 20  $\pm$ 1°C (minus 4  $\pm$ 2°F). Immediately following removal from the conditioning chamber, each device shall be subjected to the Impact Test described in SE6.3.

SE6.2 added May 25, 2007

**UL COPYRIGHTED MATERIAL –  
NOT AUTHORIZED FOR FURTHER REPRODUCTION OR  
DISTRIBUTION WITHOUT PERMISSION FROM UL**

SE6.3 Six receptacles are to be mounted to a cast metal (malleable iron) outlet box and a metallic flush-device cover plate is to be installed on the receptacle in the intended manner. The receptacle, faceplate, and box are to be placed on a steel plate at least 1/2-inch (12.7-mm) thick with the outlet facing upward. A 3 lb (1.36 kg) cylindrical weight, 1-1/4 inch (31.8 mm) in diameter and having a flat end without any sharp edges, is to be dropped from a height of 11 in (279 mm) to impact the center of each receptacle outlet. For duplex receptacles, three devices are to be tested using one outlet, and three using the other.

SE6.3 added May 25, 2007

## SE7 Accelerated Aging Test

SE7.1 A weather-resistant receptacle shall not crack or distort to the extent such that upon completion of the test each device shall be:

- a) Capable of completely mating with the intended attachment plugs both grounding and non-grounding types;
- b) Shall not crack to the extent such that a 1/32 in (0.8 mm) diameter rod can be inserted through the crack and contact live parts; and
- c) Subjected to the Dielectric Voltage-Withstand Test described in Section 60. The devices are not required to be subjected to the humidity conditioning described in 60.1.2.

SE7.1 added May 25, 2007

SE7.2 The device is to be placed in a full-draft air-circulating oven for 7 days at a temperature of 70°C (158°F). The device is to be allowed to rest at room temperature for at least one hour after removal from the oven.

SE7.2 added May 25, 2007

## SE8 Ultraviolet Light and Water Exposure Test

SE8.1 When subjected to the Ultraviolet Light and Water Exposure Test described in SE8.2, the insulating material employed in the face of a weather-resistant receptacle, shall not exhibit deterioration such as cracking, crazing, or warping, after exposure.

*Exception: Insulating material employed in the face of a weather-resistant receptacle that has been investigated in accordance with the requirements for the Ultraviolet Light Exposure Test in the Standard for Polymeric Material – Use in Electrical Equipment Evaluations, UL 746C, and so identified, is not required to comply with this requirement.*

SE8.1 added May 25, 2007

SE8.2 The receptacle is to be mounted such that the receptacle face is exposed to ultraviolet light and water by using either of the following methods:

- a) Twin enclosed carbon-arc, Type D, in accordance with ASTM G151 and ASTM G153. Method 1, continuous exposure to light and intermittent exposure to water spray, with a programmed cycle of 120 min consisting of a 102 min light exposure and an 18 min exposure to water spray with light, shall be used. The apparatus shall operate with a black-panel temperature of 63 ±3°C (145 ±5°F); or

b) Xenon-arc, Type B, in accordance with ASTM G26. Test Method A, continuous exposure to light and intermittent exposure to water spray, with a programmed cycle of 120 min consisting of a 102 min light exposure and an 18 min exposure to water spray with light, shall be used.

SE8.2 added May 25, 2007

SE8.3 The apparatus shall operate with a 6500 W, water-cooled xenon-arc lamp, borosilicate glass inner and outer optical filters, a spectral irradiance of 0.35 W/m<sup>2</sup>/nm at 340 nm and a blackpanel temperature of 63 ±3°C (145 ±5°F).

SE8.3 added May 25, 2007

SE8.4 Three representative devices in each color shall be mounted on the inside of the cylinder in the ultraviolet-light apparatus in such a way that they do not touch each other.

SE8.4 added May 25, 2007

SE8.5 For twin enclosed carbon-arc, the representative devices shall be exposed for a total of 720 h. For xenon-arc, the representative devices shall be exposed for a total of 1000 h.

SE8.5 added May 25, 2007

SE8.6 For a material that is to be evaluated in a range of colors, representative devices in the natural (when used in this color) and in the most heavily pigmented light and dark colors shall be provided to represent the color range.

SE8.6 added May 25, 2007

## MARKINGS

### SE9 General

SE9.1 A weather-resistant receptacle shall be marked with the phrase "Weather Resistant" or the abbreviation "WR" that is visible after installation with the cover plate secured as intended.

SE9.1 added May 25, 2007

SE9.2 The letters shall be a minimum of 4.8 mm (3/16 inch) in height and visible after installation.

SE9.2 added May 25, 2007

No Text on This Page

Document Was Downloaded By jianxiong chen For Use By KAI HUA (FOSHAN SHUNDE) ELECTRIC APPLIANCE CO LTD 22381 : 5/8/2008 - 10:34 AM

***UL COPYRIGHTED MATERIAL –  
NOT AUTHORIZED FOR FURTHER REPRODUCTION OR  
DISTRIBUTION WITHOUT PERMISSION FROM UL***



## APPENDIX A

### Standards for Components

Standards under which components of the products covered by this standard are evaluated include the following:

Title of Standard – UL Standard Designation

---

Configurations, Wiring Device – UL 1681  
Cover Plates for Flush-Mounted Wiring Devices – UL 514D  
Equipment Wiring Terminals for Use with Aluminum and/or Copper Conductors – UL 486E  
Fuseholders – Part 1: General Requirements – UL 4248-1  
Fuseholders – Part 4: Class CC – UL 4248-4  
Fuseholders – Part 5: Class G – UL 4248-5  
Fuseholders – Part 6: Class H – UL 4248-6  
Fuseholders – Part 8: Class J – UL 4248-8  
Fuseholders – Part 9: Class K – UL 4248-9  
Fuseholders – Part 11: Type C (Edison Base) and Type S Plug Fuse – UL 4248-11  
Fuseholders – Part 12: Class R – UL 4248-12  
Fuseholders – Part 15: Class T – UL 4248-15  
Marking and Labeling Systems – UL 969  
Outlet Boxes, Flush-Device Boxes, and Covers, Nonmetallic – UL 514C  
Outlet Boxes, Metallic – UL 514A  
Plastic Materials for Parts in Devices and Appliances, Tests for Flammability of – UL 94  
Polymeric Materials - Long Term Property Evaluations – UL 746B  
Polymeric Materials - Short Term Property Evaluations – UL 746A  
Receptacles and Switches Intended for Use with Aluminum Wire – UL 1567  
Switches, Enclosed and Dead-Front – UL 98  
Switches, General-Use Snap – UL 20  
Wire Connectors – UL 486A-486B

**UL COPYRIGHTED MATERIAL –  
NOT AUTHORIZED FOR FURTHER REPRODUCTION OR  
DISTRIBUTION WITHOUT PERMISSION FROM UL**

No Text on This Page

Document Was Downloaded By jianxiong chen For Use By KAI HUA (FOSHAN SHUNDE) ELECTRIC APPLIANCE CO LTD 22381 : 5/8/2008 - 10:34 AM

***UL COPYRIGHTED MATERIAL –  
NOT AUTHORIZED FOR FURTHER REPRODUCTION OR  
DISTRIBUTION WITHOUT PERMISSION FROM UL***

























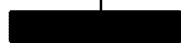







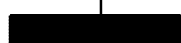



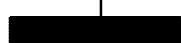

## APPENDIX B

### Wiring Device Configurations

The wiring device configuration charts illustrated in Figures 1 – 4 are reproduced from the National Electrical Manufacturers Association (NEMA) publication ANSI/NEMA WD 6 – 1997, Wiring Devices – Dimensional Specifications, copyright 1998, by NEMA, copies of which may be purchased from NEMA, 1300 North 17th Street, Rosslyn, VA 22209.

*UL COPYRIGHTED MATERIAL –  
NOT AUTHORIZED FOR FURTHER REPRODUCTION OR  
DISTRIBUTION WITHOUT PERMISSION FROM UL*

Figure 1  
NEMA configurations for specific purpose plugs and receptacles

DESCRIPTION	NEMA NUMBER	15 AMPERE		30 AMPERE		50 AMPERE	
		RECEPTACLE	PLUG	RECEPTACLE	PLUG	RECEPTACLE	PLUG
MIDGET LOCKING	125V, 2 POLE, 2 WIRE	ML1					
	125V, 2 POLE, 3 WIRE GROUNDING	ML2					
	125/250V, 3 POLE, 3 WIRE	ML3					
FSL CONFIGURATIONS	28V DC, 2 POLE, 3 WIRE GROUNDING	FSL1					
	120V, 400HZ, 2 POLE, 3 WIRE GROUNDING	FSL2					
	120V, 400 HZ, 3-PHASE 3 POLE, 4 WIRE GROUNDING	FSL3					
	120/208V, 3Ø Y, 400 HZ 4 POLE, 5 WIRE GROUNDING	FSL4					
MARINE SHIP-TO-SHORE	125V, 2 POLE, 3 WIRE GROUNDING	SS1					
	125/250V, 3 POLE, 4 WIRE GROUNDING	SS2					
TRAVEL TRAILER	120V AC, 2 POLE, 3 WIRE GROUNDING	TT					

NOTE: BLANK SPACES RESERVED FOR FUTURE CONFIGURATIONS

S4278

UL COPYRIGHTED MATERIAL –  
NOT AUTHORIZED FOR FURTHER REPRODUCTION OR  
DISTRIBUTION WITHOUT PERMISSION FROM UL

Figure 2  
NEMA configurations for straight blade plugs and receptacles

DESCRIPTION	NEMA NUMBER	15 AMPERE		20 AMPERE		30 AMPERE		50 AMPERE		60 AMPERE		
		RECEPTACLE	PLUG	RECEPTACLE	PLUG	RECEPTACLE	PLUG	RECEPTACLE	PLUG	RECEPTACLE	PLUG	
2-POLE 2-WIRE	125V	1										
	250V	2										
	277V AC	3										
	600V	4										
2-POLE 3-WIRE GROUNDING	125V	5										
	125V	5ALT										
	250V	6										
	250V	6ALT										
	277V AC	7										
	347V AC	24										
	480V AC	8										
	600V AC	9										
3-POLE 3-WIRE	125/250V	10										
	3 Ø 250V	11										
	3 Ø 480V	12										
	3 Ø 600V	13										
3-POLE 4-WIRE GROUNDING	125/250V	14										
	3 Ø 250V	15										
	3 Ø 480V	16										
	3 Ø 600V	17										
4-POLE 4-WIRE	3 Ø Y 120/208V	18										
	3 Ø Y 277/480V	19										
	3 Ø Y 347/600V	20										
4-POLE 5-WIRE GROUNDING	3 Ø Y 120/208V	21										
	3 Ø Y 277/480V	22										
	3 Ø Y 347/600V	23										

NOTE: BLANK SPACES RESERVED FOR FUTURE CONFIGURATIONS

S4279

UL COPYRIGHTED MATERIAL –  
NOT AUTHORIZED FOR FURTHER REPRODUCTION OR  
DISTRIBUTION WITHOUT PERMISSION FROM UL

Figure 3  
NEMA configurations for locking plugs and receptacles

DESCRIPTION	NEMA NUMBER	15 AMPERE		20 AMPERE		30 AMPERE		50 AMPERE		60 AMPERE	
		RECEPTACLE	PLUG	RECEPTACLE	PLUG	RECEPTACLE	PLUG	RECEPTACLE	PLUG	RECEPTACLE	PLUG
2-POLE 2-WIRE	125V	1									
	250V	2									
	277V AC	3									
	600V	4									
2-POLE 3-WIRE GROUNDING	125V	5									
	250V	6									
	277V AC	7									
	347V AC	24									
	480V AC	8									
	600V AC	9									
3-POLE 3-WIRE	125/250V	10									
	3 Ø 250V	11									
	3 Ø 480V	12									
	3 Ø 600V	13									
3-POLE 4-WIRE GROUNDING	125/250V	14									
	3 Ø 250V	15									
	3 Ø 480V	16									
	3 Ø 600V	17									
4-POLE 4-WIRE	3 Ø Y 120/208V	18									
	3 Ø Y 277/480V	19									
	3 Ø Y 347/600V	20									
4-POLE 5-WIRE GROUNDING	3 Ø Y 120/208V	21									
	3 Ø Y 277/480V	22									
	3 Ø Y 347/600V	23									

NOTE: BLANK SPACES RESERVED FOR FUTURE CONFIGURATIONS

S4280

UL COPYRIGHTED MATERIAL –  
NOT AUTHORIZED FOR FURTHER REPRODUCTION OR  
DISTRIBUTION WITHOUT PERMISSION FROM UL

**Figure 4**  
**NEMA configurations for 20A/30A 3, 4, and 5 wire locking plugs and receptacles**

DESCRIPTION	NEMA NUMBER	20 AMPERE		30 AMPERE	
		RECEPTACLE	PLUG	RECEPTACLE	PLUG
2-POLE 3-WIRE GROUNDING	125V	5-20R	5-20P	5-30R	5-30P
	250V	6-20R	6-20P	6-30R	6-30P
	277V AC	7-20R	7-20P	7-30R	7-30P
	347V AC	24-20R	24-20P	[REDACTED]	
	480V AC	8-20R	8-20P	8-30R	8-30P
	600V AC	9-20R	9-20P	9-30R	9-30P
3-POLE 3-WIRE	125/250V	10-20R	10-20P	10-30R	10-30P
	3 Ø 250V	11-20R	11-20P	11-30R	11-30P
	3 Ø 480V	12-20R	12-20P	12-30R	12-30P
	3 Ø 600V	[REDACTED]		13-30R	13-30P
3-POLE 4-WIRE GROUNDING	125/250V	14-20R	14-20P	14-30R	14-30P
	3 Ø 250V	15-20R	15-20P	15-30R	15-30P
	3 Ø 480V	16-20R	16-20P	16-30R	16-30P
	3 Ø 600V	[REDACTED]		17-30R	17-30P
4-POLE 4-WIRE	3 Ø Y 120/208V	18-20R	18-20P	18-30R	18-30P
	3 Ø Y 277/480V	19-20R	19-20P	19-30R	19-30P
	3 Ø Y 347/600V	20-20R	20-20P	20-30R	20-30P
4-POLE 5-WIRE GROUNDING	3 Ø Y 120/208V	21-20R	21-20P	21-30R	21-30P
	3 Ø Y 277/480V	22-20R	22-20P	22-30R	22-30P
	3 Ø Y 347/600V	23-20R	23-20P	23-30R	23-30P

NOTE: BLANK SPACES RESERVED FOR FUTURE CONFIGURATIONS

S4281

*UL COPYRIGHTED MATERIAL –  
 NOT AUTHORIZED FOR FURTHER REPRODUCTION OR  
 DISTRIBUTION WITHOUT PERMISSION FROM UL*

No Text on This Page

Document Was Downloaded By jianxiong chen For Use By KAI HUA (FOSHAN SHUNDE) ELECTRIC APPLIANCE CO LTD 22381 : 5/8/2008 - 10:34 AM

***UL COPYRIGHTED MATERIAL –  
NOT AUTHORIZED FOR FURTHER REPRODUCTION OR  
DISTRIBUTION WITHOUT PERMISSION FROM UL***