

## PWM Buck Controller with Enable Pin

### ■ General Description

The GT1512 is a high efficiency PFET switching regulator controller that can be used to quickly and easily develop a small, cost effective, switching buck regulator for a wide range of applications. The PWM control architecture provides for simple design without any control loop stability concerns using a wide variety of external components. The PFET architecture also allows for low component count as well as ultra-low dropout, 100% duty cycle operation. An dedicated Enable Pin provides a shutdown mode drawing only 2uA. The Enable Pin must be connected by a logic voltage level.

Current Limit protection can be implemented by measuring the voltage across the PFETs  $R_{DS(ON)}$ , thus eliminating the need for a sense resistor. The cycle-by-cycle current limit can be adjusted with a single resistor, ensuring safe operation over a range of output current.

### ■ Features

- Input voltage:3.6V to 24V
- Adjustable output voltage range :0.8V to VIN
- Duty ratio:0% to 100% PWM control
- Oscillation frequency:320KHz typ.
- Soft-start, Current limit function
- Thermal Shutdown function
- +/-1.3%(+/- 2% over temp) internal reference.
- Up to 95% Efficiency
- Dedicated enable pin.
- SOP-8L Pb-Free Package
- Low power standby mode(<5uA)

### ■ Applications

- Set-Top Box
- DSL/Cable Modem
- PC/IA
- TFT Monitor
- Battery Power Portable Application
- Distributed Power Systems
- Always On Power
- High Power LED Driver

### ■ Pin Assignments

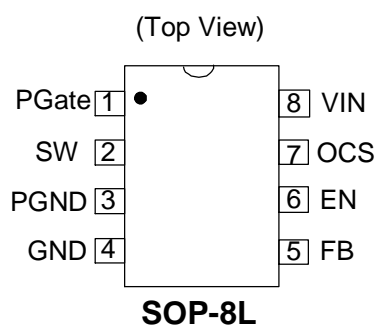

### ■ Pin Descriptions

Pin#	Name	Description
1	PGate	Gate Drive output for external PFET.
2	SW	This Pin should be connected to the PFET drain directly.
3	PGND	Power Ground.
4	GND	Signal Ground.
5	FB	The Feedback input. Connect the FB to a resistor voltage divider between the output and GND for an adjustable output voltage.
6	EN	Enable Pin.
7	OCS	Current limit threshold adjustment. Connected to an internal 100uA current source. A resistor is connected between this pin and VIN. The voltage across this resistor is compared with the SW pin voltage to determine if an over current condition has occurred.
8	VIN	Power supply input pin.

## PWM Buck Controller with Enable Pin

### Order Information

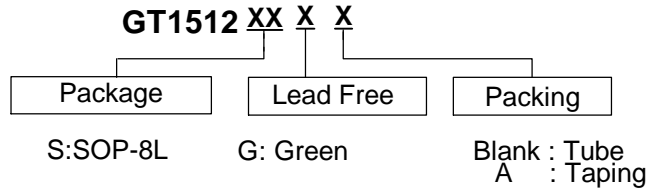

### Block Diagram

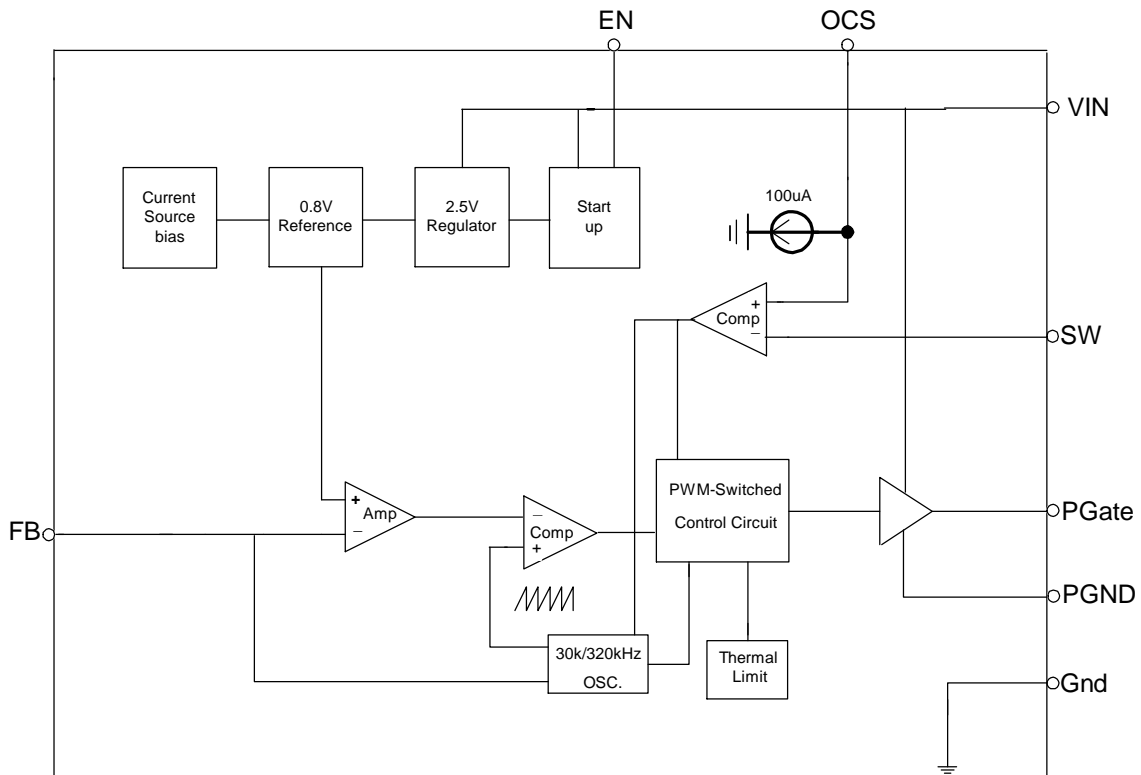

**PWM Buck Controller with Enable Pin**
**■ Absolute Maximum Ratings**

Symbol	Parameter	Rating	Unit
$V_{IN}$	Supply Voltage	+28	V
$V_{EN}$	Enable Pin input voltage	-0.3 to + $V_{IN}$	V
$V_{FB}$	Feedback Pin voltage	-0.3 to +6	V
$V_{OUT}$	Output voltage to Ground	-1	V
$P_D$	Power dissipation	Internally limited	W
$T_{ST}$	Storage temperature	-65 to +150	°C
$T_{OP}$	Operating temperature	-20 to +125	°C
$V_{OP}$	Operating voltage	+3.6 to +24	V

**■ Electrical Characteristics**

 Unless otherwise specified,  $V_{IN}=12V$   $T_a=25$  °C

Symbol	Parameter	Conditions	Min.	Typ.	Max.	Unit
$V_{FB}$	Feedback Voltage		0.784	0.8	0.816	V
$F_{OSC}$	oscillator frequency after regulation	Measure waveform at PGate pin	260	320	400	Khz
$F_{OSC1}$	Oscillator frequency when current limit	Measure waveform at PGate pin		30		Khz
$V_{IN}$	Input voltage		3.6		24	V
$V_{SH}$	EN pin input voltage	Evaluate oscillation at PGate pin	2.0			V
$V_{SL}$		Evaluate oscillation stop at PGate pin			0.8	
$I_{SH}$	EN pin input leakage current				5	uA
$I_{SL}$			-5			
$I_Q$	Quiescent Current	$V_{FB}=12$ force switching off		3	5	mA
$I_{SHDN}$	Shutdown input supply Current	$V_{EN}=0V$ $V_{IN}=12V$		5		uA
$\%V_{FB}/\Delta V_{IN}$	Feedback Line regulation	$V_{IN}=3.6V$ to 23V		0.05		%/V
$I_{FB}$	FB pin Bias Current			70	150	nA
$I_{OCS}$	OCS pin bias current		95	110	125	uA
$I_{PGATE}$	Driver Output current	Source $V_{IN}=12V, PGate=6V$		150		mA
		Sink $V_{IN}=12V, PGate=6V$		400		
EFFI	Efficiency	$V_{IN}=12V$ $V_{OUT}=5V$		92		%
$T_S$	Over temperature shutdown threshold	$T_j$ increasing	Measured from GND pin	150		°C
		$T_j$ decreasing		100		

## PWM Buck Controller with Enable Pin

### ■ Application Circuit

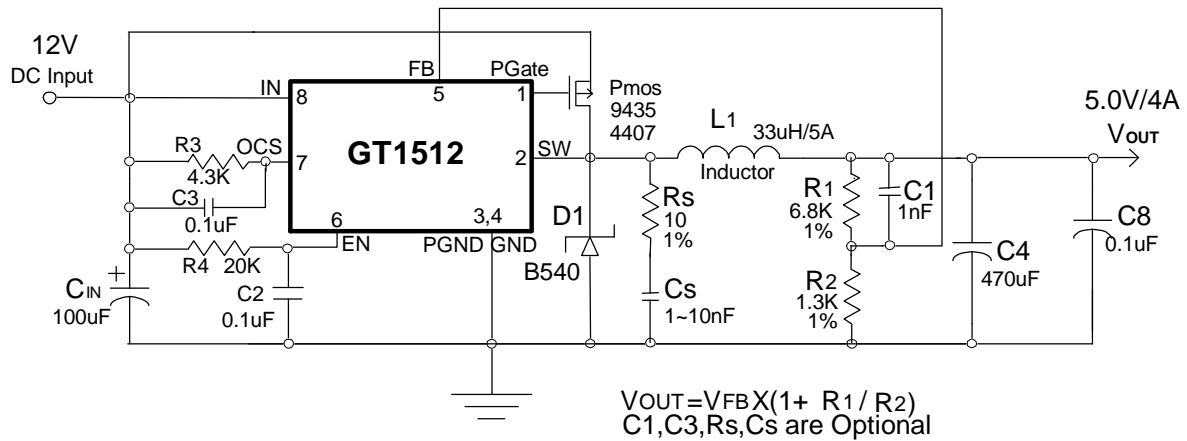

VCC=12V , I <sub>MAX</sub> =2A , I <sub>LIMIT</sub> =3.3A				VCC=12V , I <sub>MAX</sub> =3A , I <sub>LIMIT</sub> =4.0A			
V <sub>OUT</sub>	2.5V	3.3V	5V	V <sub>OUT</sub>	2.5V	3.3V	5V
L1	15uH	18uH	22uH	L1	22uH	27uH	33uH
R2/ R1	2.2K/4.7K	1.5K/4.7K	1.3K/6.8K	R1/ R2	2.2K/4.7K	1.5K/4.7K	1.3K/6.8K
Rocs	3.0K			Rocs	3.9K		

### ■ Detailed Description

#### PWM Control

The GT1512 is a voltage-mode Buck controller, It operates from 3.6V to 24V input range and supplies up to 3A to 5A Load current according to low R<sub>dsON</sub> of external PMOS. The duty cycle can be adjusted from 0% to 100% allowing a wide range of output range. Features include enable control, fixed internal soft-start, adjustable current limit, thermal shutdown.

The GT1512 is available in SO-8L package.

#### Start Up

The current Limit circuit is active during start-up. During start-up the PFET will stay on until the current limit I<sub>s</sub> trigger. If the current limit comparator is tripped first then the fold back characteristic should be taken into account. Start-up into full load may require a higher current limit set point or the load must be applied after start-up.

One problem with selecting a higher current limit is inrush current during start-up. Increasing the capacitance of C3 in parallel with R3 result in a soft-start characteristic. C3 and R3 create an RC time constant forcing current limit to activate at a lower current. The output voltage will have ramp more slowly when using the technique.

#### Switching Frequency

The GT1512 switching frequency is fixed after regulation, The typical value of frequency is 320KHz. When Current limit is triggered and the frequency drop to 1/12 of normal switching frequency. The inductor average current is greatly reduced because of the lower frequency.

#### Output Voltage Programming

Output voltage can be set by feeding back the output to the FB pin with a resistor divider network. In the

## PWM Buck Controller with Enable Pin

application circuit, The resistor divider network include R<sub>1</sub> and R<sub>2</sub>. Usually, a design is started by picking a fixed R<sub>2</sub> value and calculating the required R<sub>1</sub> with equation below.

$$V_o = 0.8 \times (R_1 + R_2) / R_2$$

Some standard value of R<sub>1</sub> and R<sub>2</sub> for most commonly used output voltage are listed below.

V <sub>o</sub> (V)	R <sub>1</sub> (KΩ)	R <sub>2</sub> (KΩ)	L <sub>1</sub> Minumum
0.8V	0	open	8.2uH
1.0V	1.0	4	8.2uH
1.2V	1.5	3	10uH
1.5V	2.0	2.2	10uH
1.8V	2.5	2	15uH
2.5V	4.7	2.2	15uH
3.3V	4.7	1.5	18uH
5.0V	6.8	1.3	22uH

Since the switch duty cycle can be as high as 100%, the maximum output voltage can be set as high as the input voltage minus the voltage drop on upper PMOS and inductor.

### Protection Features

The GT1512 has multiple protection features to prevent system circuit and external PMOS damage under abnormal conditions.

#### Over Current Protection (OCP)

Over current protection is implemented by sensing the voltage drop across the drain to source of the external high side power MOSFET. The drain to source voltage is then compared to a voltage level representing the over current threshold limit. The current limit threshold is set by external resistor connected between OCS pin and VIN. The stable current flow from VIN through resistor into OCS pin is about 100uA. When the load current reach the current limit threshold, the cycle by cycle current limit circuit turn off the external PMOS immediately to terminate the current duty cycle. The inductor current stop rising. When cycle by cycle current limit circuit is triggered, the output voltage drops as the duty cycle decreasing and the frequency reduces to 1/12 of normal switching frequency.

#### Thermal Protection (OTP)

The internal temperature sensor monitors the junction temperature. It shut down the internal control circuit and turn off the external PMOS if the junction temperature exceeds 150 °C. The regulator will restart automatically under the control of soft-start circuit when junction temperature decreases to 100°C.

#### Under Voltage Lockout

The under voltage lockout circuit of the GT1512 assures that that the PGate pin remain in high state. Lockout occurs if VIN falls below 3.3V. Normal operation resumes once VIN rises above 3.5V.

#### R<sub>DS(ON)</sub> Current Limiting

The current limit threshold is setting by the external resistor connecting from VIN supply to OCS pin. The internal 100uA sink current crossing the external resistor sets the voltage at the OCS pin. The power loss of the external resistor is less than the power loss of MOSFET, an over-current condition is triggered.

$$I_{LOAD} \times R_{DS(ON)} = I_{OCS} \times R_{OCS}$$

See above formula for setting the current limit value.

## PWM Buck Controller with Enable Pin

### Inductor Selection

For most designs, that operates with inductor of 15uH to 33uH. The inductor value can be derived from the following equation.

$$\Delta I_L = \frac{V_O}{f \times L} \times \left(1 - \frac{V_O}{V_{IN}}\right)$$

The peak inductor current is:

$$I_{L_{peak}} = I_O + \frac{\Delta I_L}{2}$$

High inductance give low inductor ripple current. Choose inductor ripple current approximately 15% of the maximum load current ,for examples 3A,  $\Delta I_L=0.4A$  , The DC current rating of the inductor should be at least equal to current limit plus half the ripple current to prevent core saturation (3A+0.2A).

### Output capacitor Selection

The output capacitor must have a higher rated voltage specification than the maximum desired output voltage including ripple. De-rating needs to be considered for long term reliability.

Output ripple voltage specification is another important factor for selecting the output capacitor. In a buck converter circuit, output ripple voltage is determined by inductor value , switching frequency ,output capacitor value and ESR. It can be calculated by the equation below:

$$\Delta V_O = \Delta I_L \times \left(ESR_{CO} + \frac{1}{8 \times f \times C_O}\right)$$

where  $C_O$  is the output capacitor value and  $ESR_{CO}$  is the Equivalent Series Resistor of output capacitor.

When low ESR ceramic capacitor is used as output capacitor, the impedance of the capacitor at the switching frequency dominates. Output ripple is mainly caused by capacitor value and inductor ripple current. The output ripple voltage calculation can be simplified to:

$$\Delta V_O = \Delta I_L \times \frac{1}{8 \times f \times C_O}$$

If the impedance of ESR at switching frequency dominates, the output ripple voltage is mainly decided by capacitor ESR and inductor ripple current. The output ripple voltage calculation can be further simplified to:

$$\Delta V_O = \Delta I_L \times ESR_{CO}$$

An aluminum electrolytic capacitors ESR value is related to the capacitance and its voltage rating. In most case , higher voltage electrolytic capacitors have lower ESR values. Most of time, capacitors with much higher voltage ratings may be needed to provide the low ESR values required for low output ripple voltage. It is recommended to replace this low ESR capacitor by using a 470u low ESR values <50mΩ .

### Thermal management and PCB layout Consideration

The thermal performance of the GT1512 is strongly affected by the PCB layout. The size of the heatsink depends on the input voltage, the output voltage, the load current and the ambient temperature.

In the GT1512 buck regulator circuit, the major power dissipating component are the GT1512, The Schottky diode and output inductor. The total power dissipation of converter circuit can be measured by input power minus output power.

$$P_{total\_loss} = V_{IN} \times I_{IN} - V_O \times I_O$$

## PWM Buck Controller with Enable Pin

The power dissipation in Schottky diode can be approximated as: (D: PWM Duty cycle)

$$P_{\text{diode\_loss}} = I_O * (1 - D) * V_{FW\_Schottky}$$

The power dissipation of inductor can be approximated as:

$$P_{\text{inductor\_loss}} = I_O^2 * R_{\text{inductor}}$$

The actual junction temperature can be calculated with power dissipation in the GT1512 and thermal impedance from junction to ambient. ( $\Theta_{JA} = 65^\circ\text{C} / \text{W}$ )

$$T_{\text{junction}} = (P_{\text{total\_loss}} - P_{\text{diode\_loss}} - P_{\text{inductor\_loss}}) * \Theta_{JA}$$

The maximum junction temperature of GT1512 is  $150^\circ\text{C}$ , which limits the maximum load current capability. The two SW pin are connected to external MOSFET drain. They are low resistance thermal conductor path and most noisy switching node. Connected a copper plane to SW pin to help thermal dissipation. The copper plane should not be too larger otherwise switching noise may be coupled to other part of circuit in PCB.

### ■ Marking Information

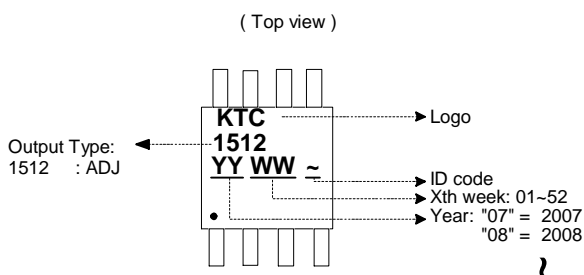

## PWM Buck Controller with Enable Pin

### ■ Package Information

Package Type: SOP-8L

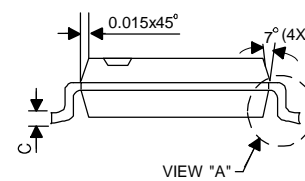
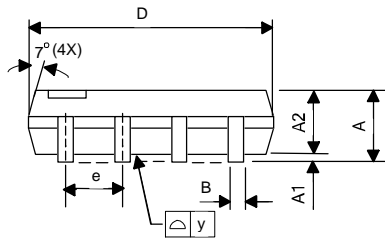
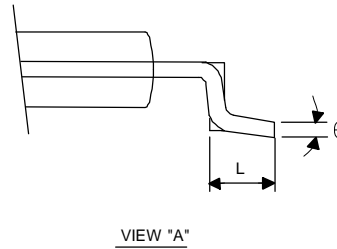
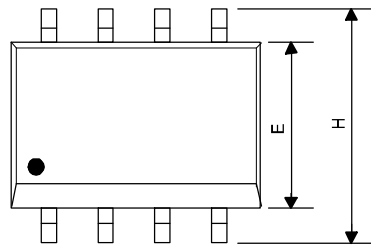

Symbol	Dimensions In Millimeters			Dimensions In Inches		
	Min.	Nom.	Max.	Min.	Nom.	Max.
A	1.40	1.60	1.75	0.055	0.063	0.069
A1	0.10	-	0.25	0.040	-	0.100
A2	1.30	1.45	1.50	0.051	0.057	0.059
B	0.33	0.41	0.51	0.013	0.016	0.020
C	0.19	0.20	0.25	0.0075	0.008	0.010
D	4.80	4.85	5.05	0.189	0.191	0.199
E	3.80	3.91	4.00	0.150	0.154	0.157
e	-	1.27	-	-	0.050	-
H	5.79	5.99	6.20	0.228	0.236	0.244
L	0.38	0.71	1.27	0.015	0.028	0.050
y	-	-	0.10	-	-	0.004
$\theta$	0°	-	8°	0°	-	8°