

# Peak Current Mode Control Applied to the Forward Converter with Active clamp

A. Fontán\*, S. Ollero\*, E. de la Cruz\*, J. Sebastián\*\*.

\* Alcatel Alsthom Corporate Research Center.  
Energy Department.  
Ramirez de Prado 5. Madrid 28045. SPAIN  
Phone : 34-1-3304658  
Fax : 34-1-3305060  
E-mail : afontan@alcatel.es  
ollero@alcatel.es  
delacruz@alcatel.es

\*\* Universidad de Oviedo.  
Area de Tecnología Electrónica.  
Campus de Viesques, s/n. Gijón 33204. SPAIN  
Phone : 34-8-5182087  
Fax : 34-8-5182068  
E-mail : sebastian@bautista.etsiig.uniovi.es

**Abstract- The Forward Converter with Active Clamp is nowadays one of the most useful topologies when low output voltage is required due to the possibility of using self driven synchronous rectification. This paper shows an study of the peak current mode control when the main mosfet current is sensed instead of the current passing through the output inductor. A dynamic study is accomplished and the control problems are shown. Finally, several practical ways to close the feedback loop avoiding the dynamic drawbacks is also presented.**

## I. INTRODUCTION

When very low output voltage (3.3 V or lower) is required, the Forward Converter with Active Clamp (FAC) [1] with self driven synchronous rectification has already been proposed as a very good solution [2][3][4]. However, only the analysis of voltage mode control can be found in the literature[8] (see Fig. 1).

In section II, the dynamic analysis of this topology using peak current mode control will be accomplished. When peak current mode control is used, it is very usual to sense the main mosfet

current instead of the output inductor one in order to reduce the losses. This method has a drawback: the mosfet's current is not a perfect image of the output inductor current due to the transformer magnetizing current.

The fact is that the open loop response of the converter with current mode control is different to the open loop response of the forward converter without Active Clamp [8], due to the magnetizing current. Actually, as it will be shown in section III, there are new problems to be solved. The reason is that a phase lag at the resonant frequency of the "equivalent" active clamp capacitor and the transformer magnetizing inductance appears. It has been called "equivalent" capacitor because, as it will be shown in the next section the capacitor seen by the converter depends on the duty cycle.

A prototype has been developed in order to validate the theoretical analysis. The main results are shown in section IV. In section V, several ideas will make easier future designs. Finally, in section VI, the conclusions and main results will be highlighted.

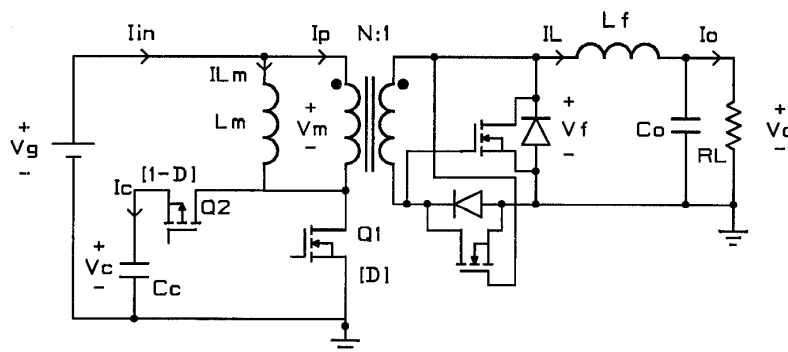

Fig. 1- Simplified schematic of the Forward with Active Clamp.

## II. DYNAMIC ANALYSIS OF THE PEAK CURRENT MODE CONTROL IN THE FAC

The nomenclature used hereafter in this paper is summarized as follows :

-Instantaneous quantities : lower-case letters with upper-case subscripts, i.e.  $i_{LF}$  (current flowing through LF in Fig. 2).

-Average quantities in a switching period : lower-case letters with lower-case subscripts. For instance,  $i_{lf}$  is the average value of  $i_{LF}$  during each switching period.

-Steady-state values of average quantities : upper-case letters with upper-case subscripts. For example,  $I_{LF}$  is the steady state value of the average current  $i_{lf}$ .

-Small-signal perturbations of average quantities : lower-case letters and subscripts with dash, i.e.  $\hat{i}_{lf}$  is the small-signal perturbation of the average current  $i_{lf}$ .

It is possible to appreciate graphically the meaning of those quantities in Fig. 2.

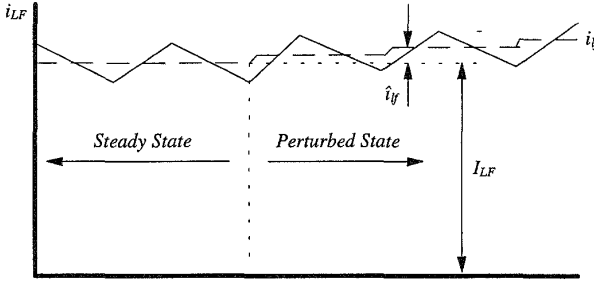

Fig. 2- Different components of the instantaneous current  $i_{LF}$ .

The main waveforms of the Forward Converter with Active Clamp and a deep analysis of this topology can be found in [1][2][3][4]. All the elements in this converter are assumed to have no losses and to be ideal. However, a deeper analysis with parasitic elements has been developed using Pspice.

It is going to be assumed that the converter is working in continuous conduction mode. The method used to obtain the small signal analysis has been widely reported [5][6][7]. Applying the first Kirtchoff law to the primary side of the transformer and averaging it during a switching period we can obtain,

$$v_m = v_g \cdot d + (v_g - v_c) \cdot (1-d) \quad (1)$$

This equation can be divided into its steady state and perturbed components,

$$V_m = V_g - (1-D) \cdot V_c \quad (2)$$

$$\hat{v}_m = \hat{v}_g - (1-D) \cdot \hat{v}_c + \hat{d} \cdot V_c$$

Assuming ideal behavior the steady state voltage in the transformer primary side must satisfy

$$V_m = 0 \quad (3)$$

Thus, it is obtained

$$\hat{v}_m = \hat{v}_g - (1-D) \cdot \hat{v}_c + \hat{d} \cdot \frac{V_g}{(1-D)} \quad (4)$$

The clamp capacitor current,  $i_c$ , can be expressed in terms of  $i_{lm}$

$$i_c = i_{lm} \cdot (1-d) \quad (5)$$

However,  $i_c$  is zero (mean current in a capacitor) thus,

$$I_{lm} = 0 \quad (6)$$

The small signal components are

$$\hat{i}_c = \hat{i}_{lm} \cdot (1-D) - I_{lm} \cdot \hat{d} \quad (7)$$

Taking (6) into account,

$$\hat{i}_c = \hat{i}_{lm} \cdot (1-D) \quad (8)$$

The same considerations can be established for the transformer currents. From Fig. 1 :

$$i_{in} = i_{lm} + i_p = \frac{v_m}{s \cdot Lm} + i_p \quad (9)$$

The small signal equation is

$$\hat{i}_{in} = \hat{i}_{lm} + \hat{i}_p = \frac{\hat{v}_m}{s \cdot Lm} + \hat{i}_p \quad (10)$$

The relationship between the primary and the secondary voltages can be summarized as follows

$$\hat{v}_f = \frac{\hat{v}_g \cdot D + V_g \cdot \hat{d}}{N} \quad (11)$$

The relationship between the primary and secondary currents is

$$\hat{i}_p = \frac{I_o \cdot \hat{d} + \hat{i}_l \cdot D}{N} \quad (12)$$

Now, the relationship between the main switch current and the input current will be calculated as follows

$$i_q = i_{in} \cdot d \quad (13)$$

$$I_q = I_{in} \cdot D = I_p \cdot D \quad (14)$$

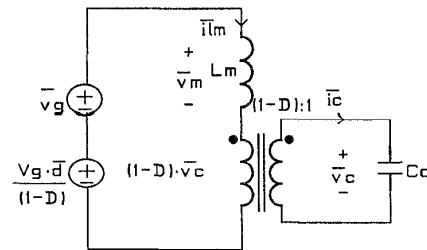

Fig. 3.- Small signal equivalent circuit of the clamp capacitor circuitry.

The small signal components are

$$\hat{i}_q = I_{in} \cdot \hat{d} + \hat{i}_{in} \cdot D \quad (15)$$

From (4) and (8) the small signal equivalent circuit of the clamp capacitor circuit can be obtained (see Fig. 3).

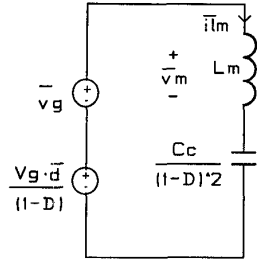

Fig. 4.- Small signal equivalent circuit of the clamp capacitor circuitry. The clamp capacitor has been replaced by its equivalent one.

A simplified circuit can be obtained passing the capacitor to the primary side of the transformer (see Fig. 4). It should be noted, as it will be remarked later, that the clamp capacitor has an equivalent value dependent on the working duty cycle. It means that any resonance due to this capacitor will have a duty cycle dependence and therefore a more difficult compensation.

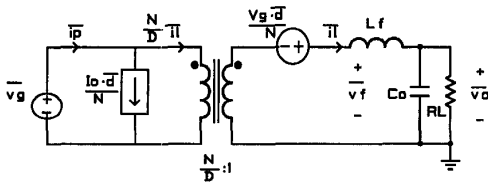

Fig. 5.- FAC equivalent small signal circuit

The equivalent circuit of the rest of the topology has been depicted in Fig. 5.

It should be noted that the circuit shown in Fig. 1 can be divided in two circuits, both with

the same main transistor Q1 (see Fig. 1). One is the clamping circuitry, and the other one is an ideal classical forward converter with no magnetic reset circuitry. This conclusion could also be extracted from the consideration of the active clamp as a combination of the classical forward (with an ideal transformer) and a boost with infinite load and being its inductor the magnetizing one (see Fig. 6). Both equivalent converters (Fig. 7 and Fig. 9) are operating with the same duty cycle. It should be noted that both converters are working in continuous conduction mode because both the forward converter output rectifiers and the boost converter rectifier (the clamp mosfet) are mosfets instead of diodes so the current can flow in both directions.

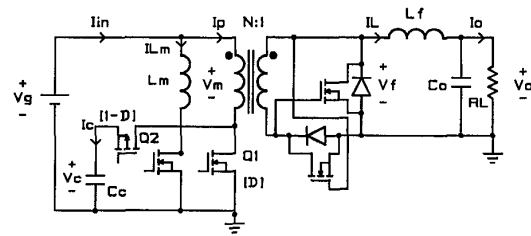

Fig. 6.- FAC divided into its two equivalent converters

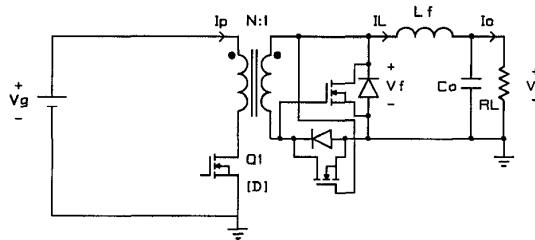

Fig. 7.- The intrinsic forward converter of the FAC

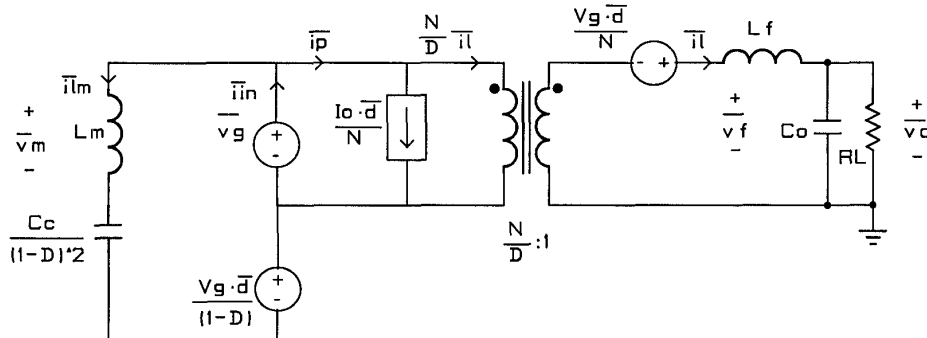

Fig. 8.- Complete small signal model of the FAC

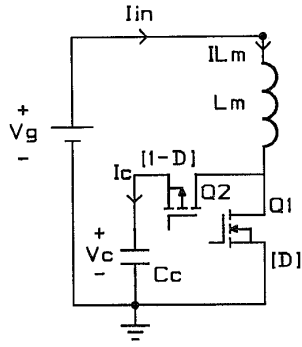

Fig. 9.- The intrinsic boost converter of the FAC. It is possible to appreciate how the load is infinite.

Finally, the complete small signal circuit can be drawn (see Fig. 8). It is perfectly in concordance with the small signal analysis of the forward and boost converters in the conditions mentioned before (working in continuous conduction mode and the boost with infinite load). The results are the same as those of [7] in such conditions. Fig. 8 shows the final equivalent small signal circuit.

As it can be appreciated in Fig. 8 the clamp capacitor does not affect to the input to output relationship of the typical forward converter when it is controlled in voltage mode control. As it is explained in [8] this is not true when ZVS is reached.

When the peak current mode control is used and the output filter current is sensed, the converter works in the same way as any other forward converter. On the other hand, if the main switch current is sensed the effect of the clamp capacitor is very important. In fact, the main switch current depends on the magnetizing current

$$\hat{i}_q = \frac{I_o \cdot D}{N \cdot (1-D)} \cdot \hat{d} + \hat{i}_{lm} \cdot D \quad (16)$$

This equation establishes the relationship between the main switch current (which is going to be sensed) and the magnetizing current (that depends on the clamp capacitor and magnetizing inductor dynamic behavior).

In order to obtain the expressions that relate the control to output voltages in the peak current mode control of the FAC converter, the process that is going to be followed is the same as the one that has been widely used and explained in [7].

The main difference is that the current sensed is not the output inductor one, on the contrary it is obtained from the main mosfet.

In Fig. 10 the main mosfet current can be seen. As it is shown its value is the addition of two quantities, the output inductor current reflected on the primary side of the transformer and the

magnetizing current (this current has also been drawn at the bottom of the figure). The stabilizing ramp added to the control voltage can also be appreciated, \$m\_0\$ being its slope. From this figure, \$m\_1\$ corresponds to the output current slope, \$m\_3\$ is due to the magnetizing inductance slope and \$m\_2\$ is the total slope, addition of \$m\_1\$ and \$m\_3\$.

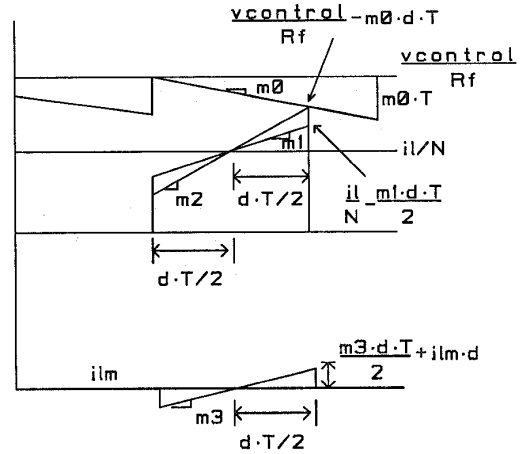

Fig. 10.- Detailed view of the main switch current and voltage control intersection.

These slopes have been calculated in order to obtain the necessary relationships between them. \$M\_1\$ is due to the output filter inductor as follows :

$$M_1 = \frac{V_g \cdot (1-D)}{N \cdot L_f} \quad (17)$$

$$\hat{m}_1 = \frac{\hat{v}_g - N \cdot \hat{v}_o}{N \cdot L_f} \quad (18)$$

\$M\_3\$ is due to the magnetizing inductance :

$$M_3 = \frac{V_g}{L_m} \quad (19)$$

$$\hat{m}_3 = \frac{\hat{v}_g}{L_m} \quad (20)$$

The relationship between the different slopes can be easily deduced from Fig. 10,

$$\frac{i_l}{N} + m_2 \cdot \frac{d \cdot T}{2} + i_{lm} \cdot d = \quad (21)$$

$$\frac{v_{control}}{Rf} - m_o \cdot d \cdot T$$

where \$Rf\$ is a factor to traduce the control voltage to a current (in Fig. 10 only currents have been drawn).

Assuming that the compensating ramp is constant, \$\hat{m}\_o = 0 \Rightarrow m\_o = M\_o\$

$$(22)$$

The perturbed components are

$$\frac{\hat{i}_l}{N} + M_2 \cdot \frac{\hat{d} \cdot T}{2} + \hat{m}_2 \cdot \frac{D \cdot T}{2} \quad (23)$$

$$+ I_{lm} \cdot \hat{d} + \hat{i}_{lm} \cdot D =$$

$$\frac{\hat{v}_{control}}{R_f} - m_o \cdot \hat{d} \cdot T$$

Defining the constant K,

$$K = \frac{M_2 \cdot T}{2} + M_o \cdot T = \left( \frac{M_2}{2} + M_o \right) \cdot T \quad (24)$$

It can be observed that  $m_2 = m_1 + m_3$ . (See Fig. 10).

$$\hat{m}_2 = \hat{m}_1 + \hat{m}_3 = \frac{\hat{v}_g}{N} \cdot \left( \frac{1}{L_f} + \frac{N}{L_m} \right) - \frac{\hat{v}_o}{L_f} \quad (25)$$

Thus,

$$\hat{d} = \frac{1}{K} \cdot \left( \frac{\hat{v}_{control}}{R_f} - \frac{\hat{i}_l}{N} + \frac{D \cdot T}{2 \cdot L_f} \cdot \hat{v}_o - \hat{i}_{lm} \cdot D \right) \quad (26)$$

With this result, Fig. 12 can be obtained in order to facilitate the calculation of the transfer function using computer simulations.

### III. NEW TRANSFER FUNCTION CHARACTERISTICS

From Fig. 12, several important conclusions can be achieved :

- The control voltage depends on the magnetizing current.
- The magnetizing current could have an "infinite" value at the  $L_m$  and  $C_c$  resonance frequency,

$$f = \frac{1}{2 \cdot \pi \cdot \sqrt{L_m \cdot \frac{C_c}{(1-D)^2}}} \quad (27)$$

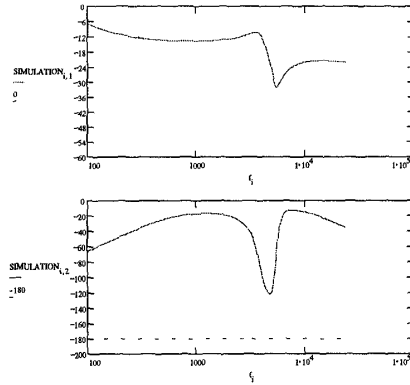

Fig. 11.- Simulation made with Pspice from the model of the Fig. 12

It is very interesting to remark, that the clamp capacitor has an equivalent value dependent on the working duty cycle. This fact will make more difficult to close the feedback loop because it means that any resonance due to this capacitor will have a duty cycle dependency.

A Pspice simulation of the FAC converter using the circuit of Fig. 12 is shown in Fig. 11. It should be noted how a very important phase lag appears at 6KHz. The same results have been obtained in a real prototype. (See section VI).

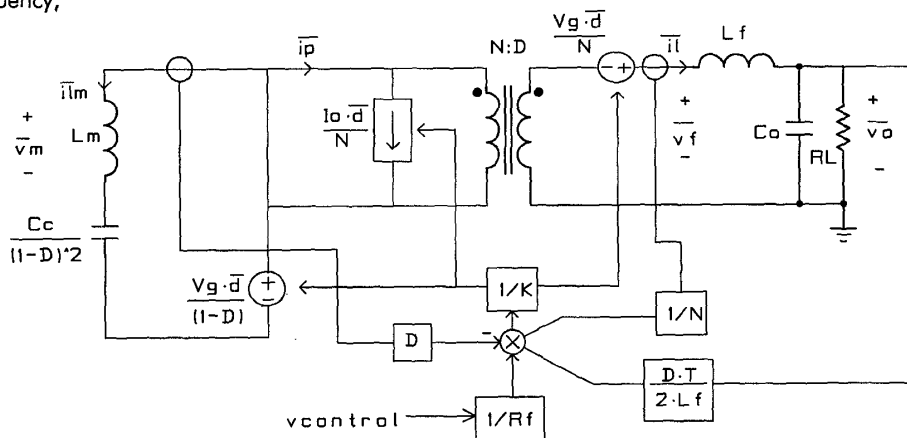

Fig. 12.- Small signal model of the FAC in peak current control mode to calculate the control to output transfer function.

#### IV. EXPERIMENTAL RESULTS

An isolated FAC prototype working in peak current control mode (sensing the main mosfet current) with the following features has been developed in order to validate the theoretical analysis :

Input Voltage 48 V

Output Voltage 5 V

Output Power 100 W

Switching frequency 100 KHz

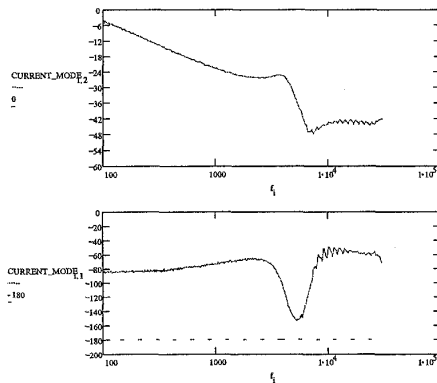

Fig. 13.-FAC with current mode control

In figure 13 the control to output bode plots of the peak current mode control of the prototype can be observed. It is possible to appreciate a phase lag at 6KHz due to the magnetizing current. The classical current mode controlled forward converter presents an open loop response with a gain downslope of 20 dB per decade and its correspondent -90 degrees of phase shift. In this case, due to the effect of the transformer magnetizing inductance and the Active Clamp capacitor, an additional phase lag appears at the resonance frequency. The resonance at 6KHz can be seen in Fig. 13. Fig. 14 shows a comparison between the converter with an Active Clamp capacitor of 100nF and of 1.5uF. The resulting bode plots show how the resonance is shifted to lower frequencies when the capacitor is higher.

#### V. SOLUTIONS TO THE PROBLEM

The solution to the phase lag implies a correct design of the transformer and the clamp circuitry. Of course different control approaches can give good results (ie. feedforward). Nevertheless, an adequate design can avoid control problems.

- Using a big capacitor force the resonance to be shifted at low frequencies. There are two drawbacks: The transformer could be saturated during transients and the loop could be conditionally stable at low frequencies. This situation must be avoided if it is possible.

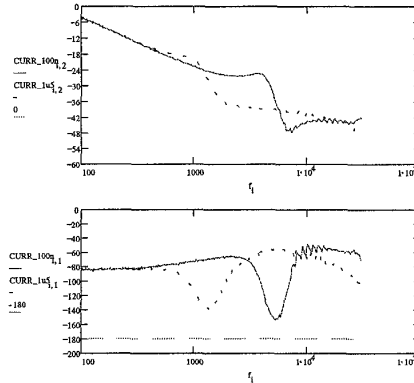

Fig. 14.-Different results when using several Active Clamp capacitor values. Continuous line : With a 100nF capacitor. Dot line : With a 1.5uF capacitor.

- Using a small Active Clamp capacitor shifts the resonance at frequencies higher than the necessary cross frequency. The inconvenient of this method is that the capacitor required by the power stage criteria (to keep the mosfet voltage under certain limits) could be higher than the estimated for good dynamic performance. It is also interesting to reduce the magnetizing inductor as much as possible to contribute to this effect.
- In order to damp the LC filter formed by the magnetizing inductance and the clamp capacitor, it is possible to add a resistor in series with the Active Clamp capacitor. In Fig. 15 a comparison between the open loop response without resistor and with 10 Ohm, 30 Ohm and 100 Ohm resistors is shown. However, the efficiency decreases with this method. It should only be used in cases in which there are high magnetizing inductors, so the clamp capacitor currents are small.
- Sensing in secondary. Of course the effect of the magnetizing current would be avoided.

In our prototype the solution implemented was to reduce the transformer magnetizing inductance to 300uH using a clamp capacitor of 100nF (The resonance is at frequency higher than 10KHz).

With this design it is assured that the desired bandwidth (2.5 KHz) is obtained (see Fig. 16).

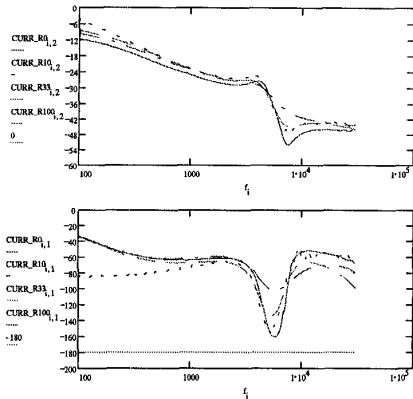

Fig. 15.-Comparison between FAC with different series resistors. The legend indicates the resistor value (ie. CURR\_R33 means 33 Ohm ,current mode control)

## VI. CONCLUSIONS

When very low output voltage (3.3 V or lower) is required, the Forward with Active Clamp with self driven synchronous rectification has already been proposed as a very good solution. Its main characteristics have been also presented in several papers [2][3][4]. The main dynamic features of this converter working in peak current mode control, when the main mosfet current is sensed, have been analyzed in this paper.

The small signal analysis of this converter shows that if the clamping network is not well damped, a very important dynamic degradation can occur at frequencies depending on the clamp capacitor, the magnetizing inductance of the transformer and the duty cycle. This fact could make difficult to compensate the feedback loop.

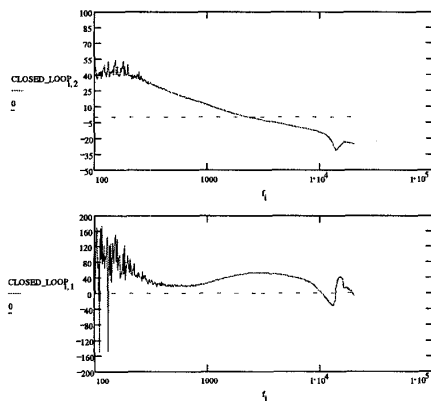

Fig. 16.-Closed loop measurement. (Worst case).

An equivalent circuit has been provided, and some simulations have been compared with

a real prototype in order to validate the small signal model.

Finally, advises have been given to avoid dynamic problems when designing this kind of circuits. An adequate design can improve the dynamic characteristics of the converter.

## REFERENCES

- [1] B. Carsten, "High Power SMPS Require Intrinsic Reliability", PCI, 1981, pp 118-132.
- [2] I.D. Jitaru and G.Cocina, "High Efficiency DC/DC Converter", Applied Power Electronics Conference (APEC), 1994, pp. 638-644.
- [3] J.A. Cobos, O.García,J.Sebastián, J.Uceda and F.Aldana, "Optimized synchronous rectification stage for low output voltage (3.3 V) DC/DC conversion", IEEE PESC 1994.
- [4] J.A. Cobos, O Garcia, J. Sebastián, J. Uceda, "Active clamp PWM forward converter with self driven synchronous rectification", Universidad Politécnica de Madrid 1993.
- [5] R.D. Middlebrook and Slobodan Cuk "A General Approach to Modeling Switching-Converter Power Stages", Power Electronics Specialists Conference (PESC), 1976.
- [6] R.D. Middlebrook "Modelling Current Programmed Buck and Boost Regulators", IEEE Transactions on Power Electronics Vol 4 N°1 April 1989.
- [7] R.D. Middlebrook "Topics in Multiple Loop Regulators and Current Mode Programming", IEEE Transactions on Power Electronics Vol PE-2 N°2 April 1987.
- [8] G.Stojcic', F.C.Lee, S.Hiti. "Small Signal Characterization of Active Clamp PWM Converters". Proceedings of the Virginia Power Electronics Conference, Blacksburg, VA September 1995.