



UCC38C42 25-Watt Self-Resonant Reset Forward Converter

Reference Design

UCC38C42 25-Watt Self-Resonant Reset Forward Converter

Lisa Dinwoodie

Power Supply Control Products

Contents

1	Introduction	2
2	Features	2
3	Schematic	3
4	Reference Design Layout	4
5	Circuit Description	5
6	Performance Data	6
7	Caution	8
8	References	8
9	List of Materials	9

1 Introduction

This reference design presents a self-resonant reset forward converter using the UCC38C42 BiCMOS Low-Power Current-Mode PWM Controller. The input voltage for this converter is compatible with the telecom input voltage range of 36 V_{DC} to 72 V_{DC}. The converter is designed to operate at a switching frequency of 525 kHz, requires minimal parts, and supports an isolated 2.5-V 10-A output. The complete schematic, list of materials, board layout, circuit description, and design performance curves are included.

2 Features

- Fixed Telecom Input Range: 36 V_{DC} To 72 V_{DC}
- 2.5-V Output Voltage
- 10-A Maximum Output Load, 1-A Minimum Output Load, Total 25-W Maximum Continuous Power
- High Efficiency 525-khz Switching Frequency
- Isolated Forward Topology
- Self-Resonant Reset
- Current Mode Control With Slope Compensation
- Soft Start
- Synchronization Input

3 Schematic

Figure 1 shows the schematic of the design.

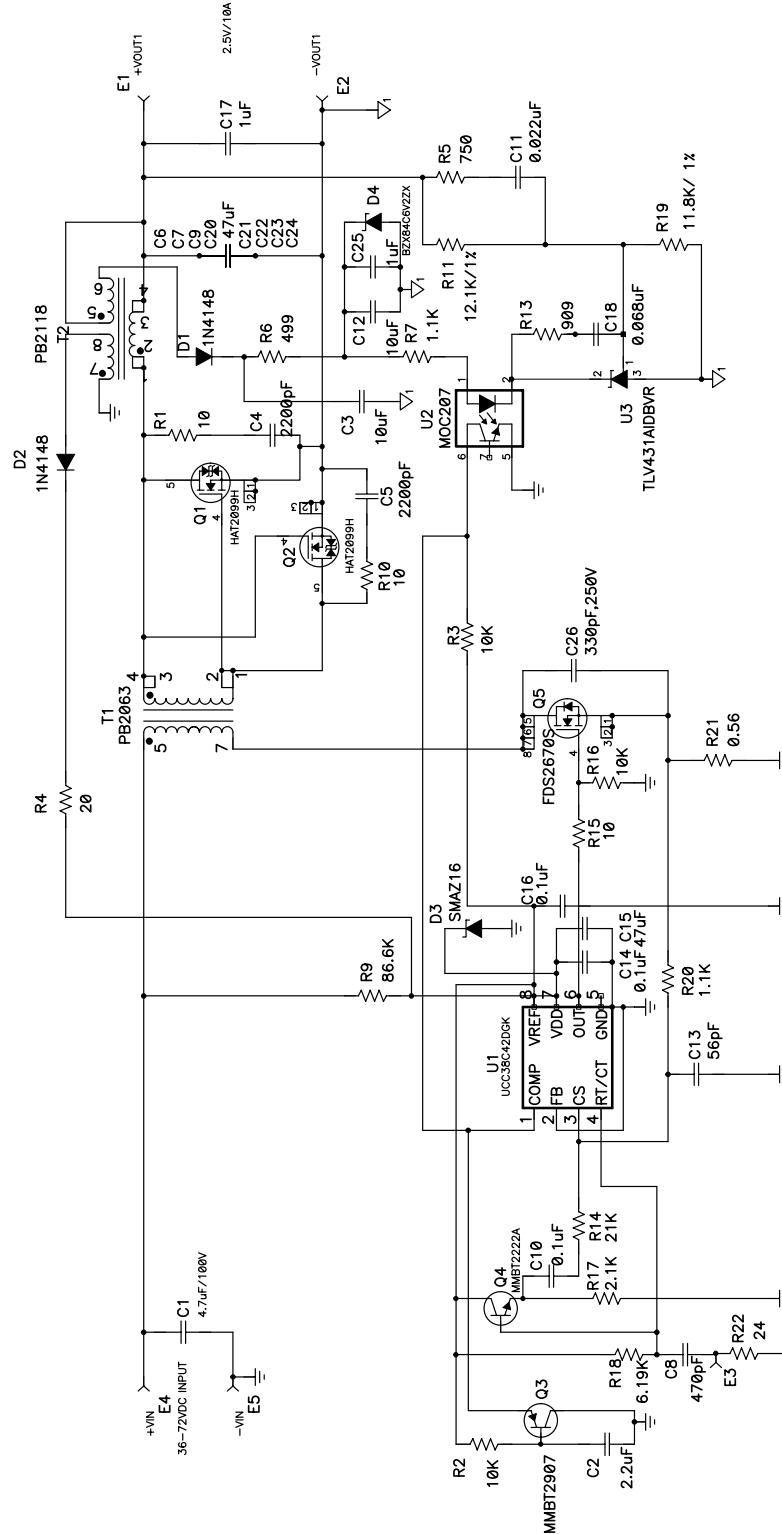

Figure 1. Self-Resonant Reset Forward Converter Utilizing the UCC38C42.

4 Reference Design Layout

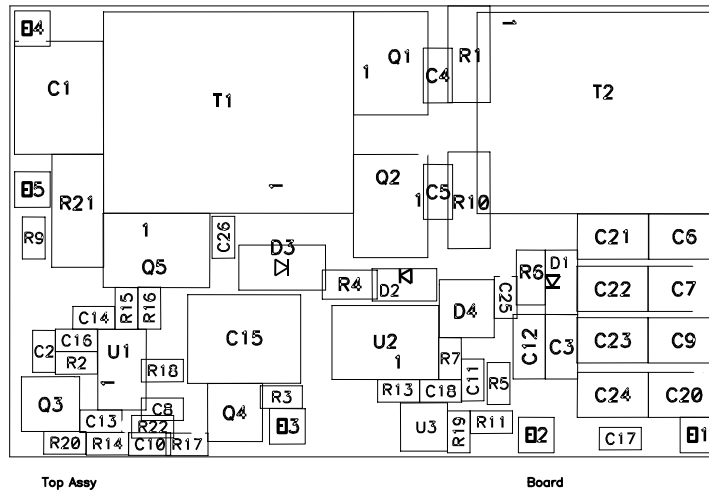

Figure 2. Top Layer Assembly

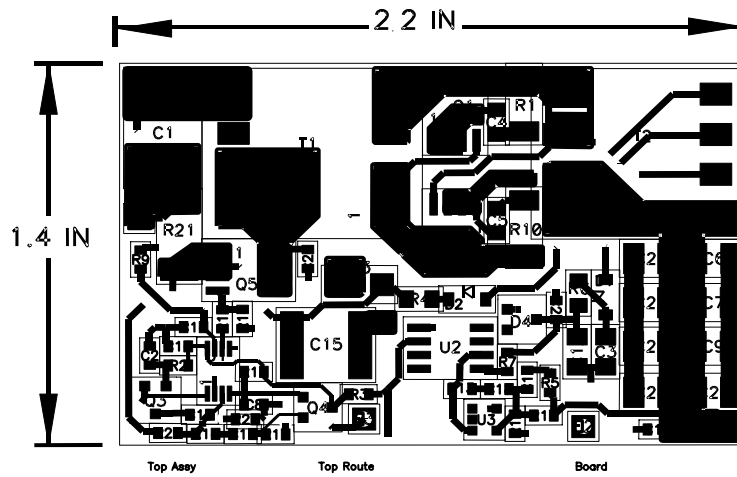

Figure 3. Top Layer

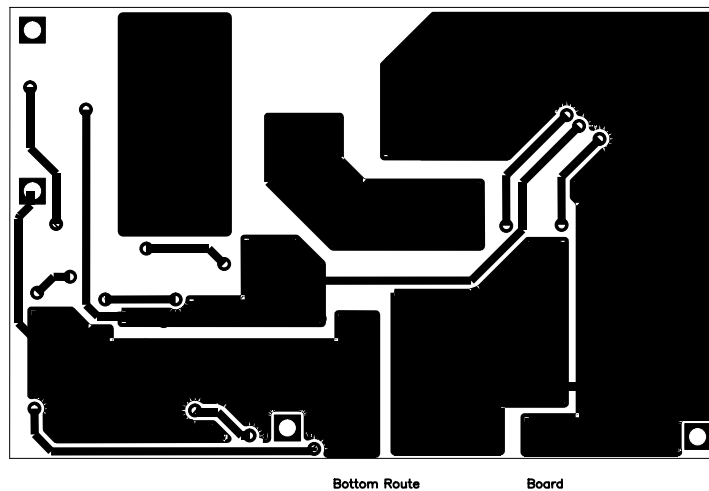

Figure 4. Bottom Layer

5 Circuit Description

A brief description of the circuit elements follows:

- Transformer T1, coupled inductor T2, MOSFETS Q1, Q2, and Q5, input capacitor C1, output capacitors C6, C7, C9, C20, C21, C22, C23, and C24, form the power stage of the converter. Q5 is the primary side switch. Because of the low output voltage, Q1 and Q2 synchronous rectifiers are used on the secondary side instead of conventional Schottky diodes.
- Power resistor R21 senses the primary switch current and converts this current into a voltage to be sensed by the primary side controller current sense amplifier.
- Capacitor C26, combined with the reflected junction capacitance of the forward synchronous rectifier and its snubber capacitor, the winding capacitance of T1, and the output capacitance of the primary switch, form a resonant tank circuit that resets the transformer core.
- Capacitor C17 filters out high frequency noise on the output bus directly at the output terminals.
- Resistor R1 and capacitor C4 make up the voltage snubber for Q1. Resistor R10 and capacitor C5 provide snubbing for Q2.
- Resistor R9 supplies the start up current to the primary side controller, U1. Operating current is provided through an auxiliary winding on the coupled inductor T2 and rectified through diode D2, current limiting resistor R4, and bulk capacitor C15. The IC is protected by clamping the bias voltage with zener diode D3.
- Decoupling to the IC is performed by C14 and C16 which should always be good quality low ESR/ESL type capacitors placed as close to the IC pins as possible and returned directly to the IC ground reference.
- Transistor Q3, resistor R2, and capacitor C2 provide soft start.
- Resistor R18 and capacitor C8 provide a charge and discharge path for the internal oscillator, setting the switching frequency of the controller. Resistor R22 provides a means of inserting an external synchronization pulse into the circuit.
- Transistor Q4, resistors R17 and R14, and capacitor C10 add slope compensation to the current signal.
- Resistor R20 and capacitor C13 filter out leading edge current spikes which are caused by the reverse recovery of the body drain diode of the secondary side switches, equivalent capacitive loading on the secondary, and parasitic circuit inductances.
- The gate drive circuitry to the primary side switch is composed of the gate drive resistor R15 (necessary for damping any oscillations resulting from the input capacitance of Q5 and any parasitic stray inductances) and pull down resistor R16.
- The voltage sense feedback loop is comprised of the TLV431 voltage reference and error amplifier U3 and the opto-isolator U2. Resistors R11 and R19 divide the output voltage for the comparator. Resistors R5 and R13 and capacitors C11 and C18 set up a Type III compensator and provide the necessary gain poles and zeros to stabilize the control loop. Resistors R7 and R3 set the gain across the isolation boundary. A well regulated and filtered bias is supplied to the LED of the opto-isolator by way of an auxiliary winding on T2, diode D1, resistor R6, capacitors C3, C12, and C25, and zener diode D4.

6 Performance Data

The following figures show the performance of a circuit built as described. In Figure 5, efficiencies greater than 82% are achieved at minimum input voltage. In Figure 6 load regulation of approximately $\pm 1\%$ is achieved. Figure 7 shows the output voltage range as a function of input line and output load.

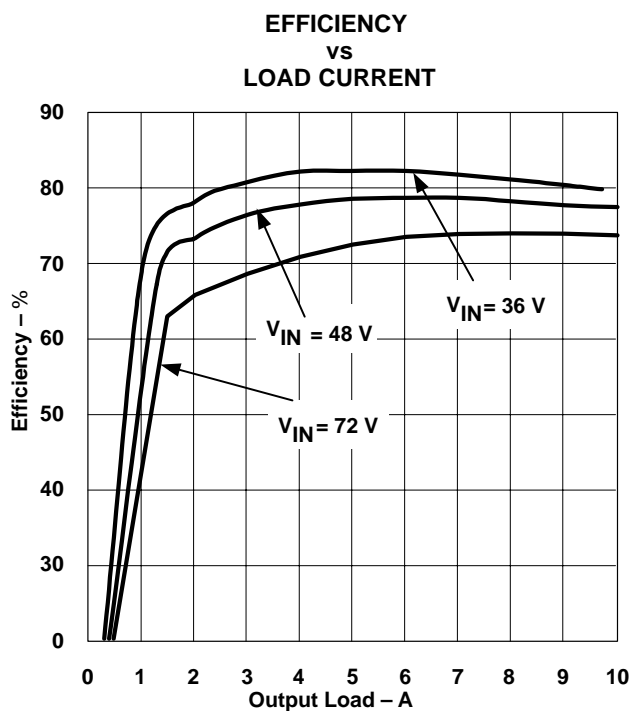

Figure 5

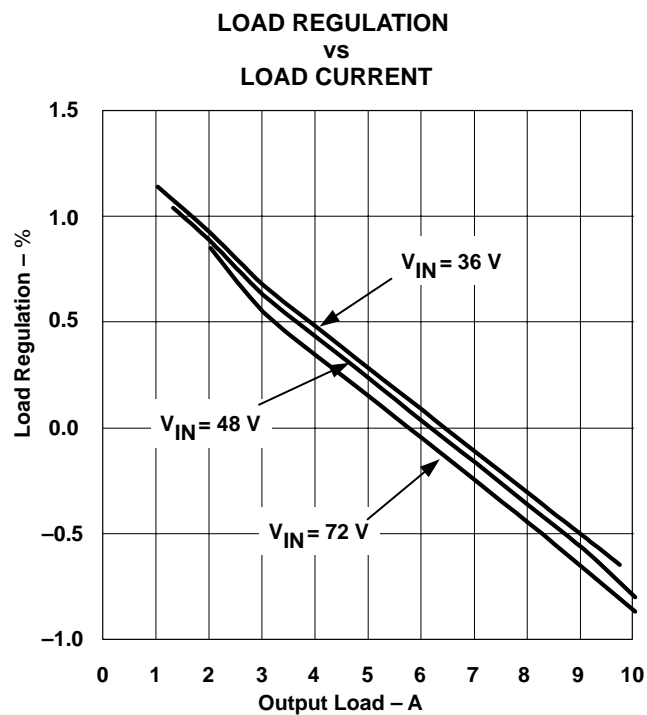

Figure 6

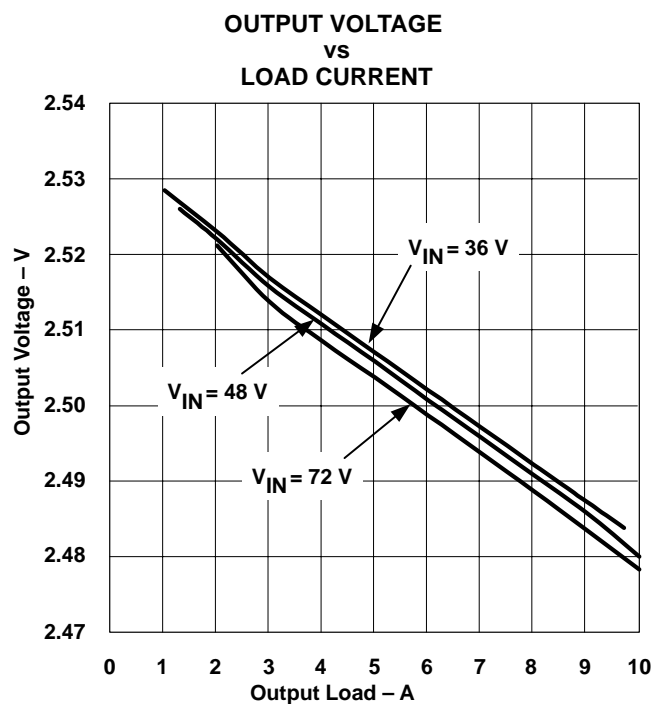
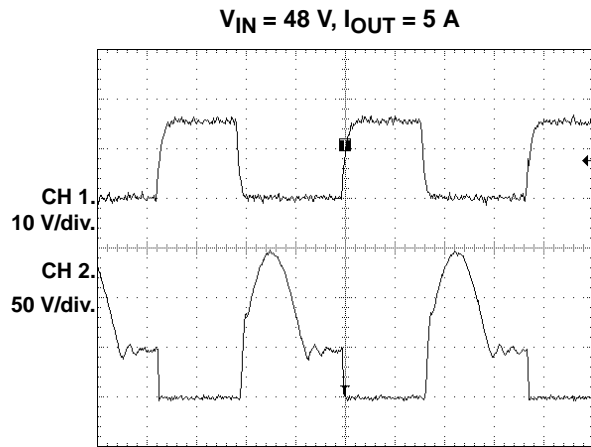
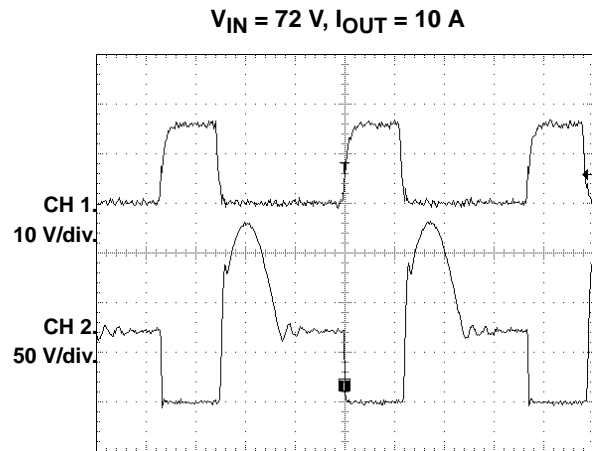

Figure 7

Figures 8 through 12 show the drain to source voltage of the main power switch. Channel 1 is the gate drive waveform, channel 2 is the drain to source voltage. All of the magnetizing energy is fully recovered when the drain to source voltage returns to the input voltage level.



t – time – 500 ns/div.
Figure 8



t – time – 500 ns/div.
Figure 9

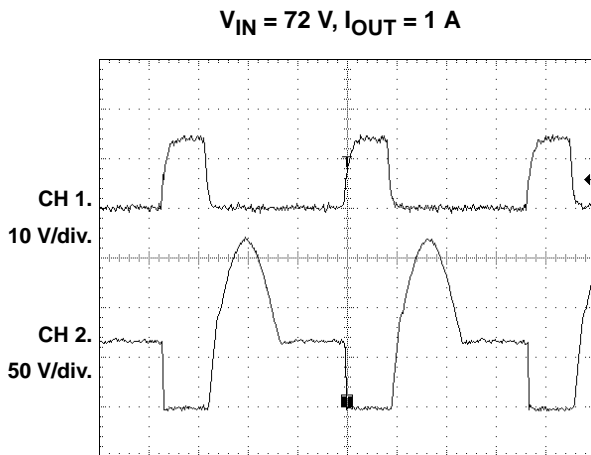

t – time – 500 ns/div.
Figure 10

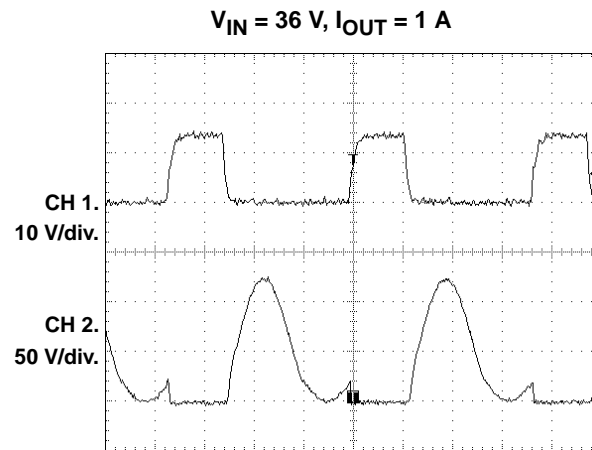

t – time – 500 ns/div.
Figure 11

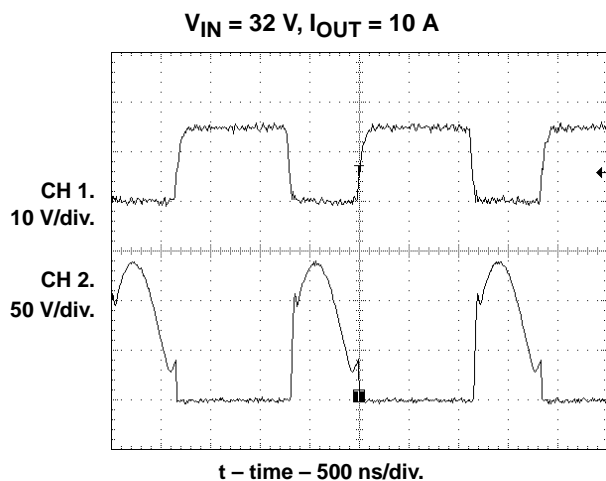

Figure 12

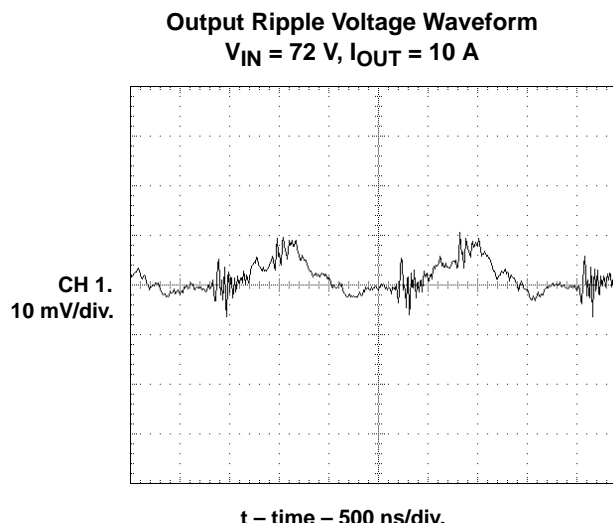

Figure 13

Output Transient Response to a Load Step
2.5 A to 7.5 A.

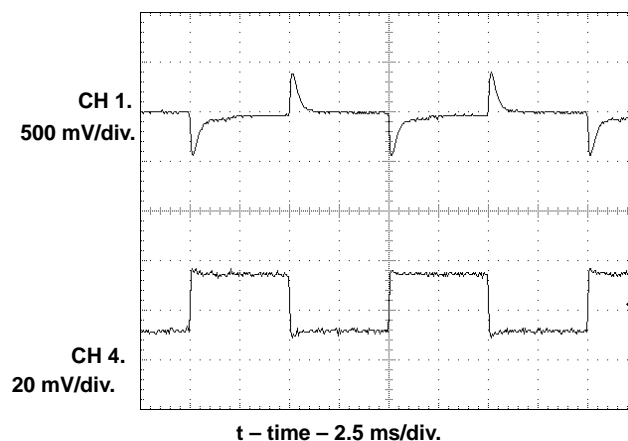

Figure 14

7 Caution

This reference design contains high-voltage levels, those exceeding 75 V. These voltages are present at, but not limited to, the drain node of the primary switch MOSFET. Proper precautions must be taken when working with modules built to this design. Serious injury can occur if proper safety precautions are not followed.

8 References

UCC38C42 Data Sheet, *BiCMOS Low-power Current-mode PWM Controller*, TI Literature number SLUS458B.

Andreycak, Bill, *The UCC38C42 Family of High-Speed, BiCMOS Current Mode PWM Controllers*, TI Literature Number SLUA257.

9 List of Materials

	Reference	Qty	Description	Manufacturer	Part Number
Capacitor	C1	1	Ceramic, 4.7 μ F, \pm 20%, 100 V, X7R, CKG57D	TDK	CKG57DX7R2A475M
	C2	1	Ceramic, 2.2 μ F, +80%/-20%, 10 V, Y5V, 0603	TDK	C1608Y5V1A225Z
	C3, C12	2	Ceramic, 10 μ F, \pm 20%, 10 V, X5R, 1206	TDK	C3216X5R1A106M
	C4, C5	2	Ceramic, 2200 pF, \pm 10%, 100 V, X7R, 0805	TDK	C2012X7R2A222K
	C6, C7, C9, C20, C21, C22, C23, C24	8	Ceramic, 47 μ F, \pm 10%, 6.3 V, X5R, 1210	TDK	C3225X5R0J476M
	C8	1	Ceramic, 470 pF, \pm 5%, 50 V, C0G, 0603	TDK	C1608COG1H471J
	C10, C14, C16	3	Ceramic, 0.1 μ F, \pm 10%, 50 V, X7R, 0603	TDK	C1608X7R1H104K
	C11	1	Ceramic, 0.022 μ F, \pm 10%, 50 V, X5R, 0805	TDK	C2012X7R1H223K
	C13	1	Ceramic, 56 pF, \pm 5%, 50 V, C0G, 0603	TDK	C1608COG1H560J
	C15	1	Ceramic, 47 μ F, \pm 20%, 25 V, X5R, CKG57D	TDK	CKG57DX5R1E476M
	C17, C25	2	Ceramic, 1 μ F, \pm 10%, 10 V, X5R, 0603	TDK	C1608X5R1A105K
	C18	1	Ceramic, 68000 pF, \pm 10%, 50 V, X7R, 0603	TDK	C1608X7R1H683K
	C26	1	Ceramic, 330 pF, \pm 10%, 250 V, C0G, 0603	TDK	C1608COG2E331K
	Diode	D1, D2	2	Schottky, 75 V, 350 mW, SOD-123	Diodes, Inc.
D3		1	Zener, SMD, 16 V, 1 W, SMA	Diodes, Inc.	SMAZ16-13
D4		1	Zener, SMD, 6.2 V, 350 mW, SOT-23	Zetex, Inc.	BZX84C6V2TA
Inductor	L1	1	2 μ H, RM5, SMD	Pulse	PB2118
MOSFET	Q1, Q2	2	N-channel, 30 V, 50 A, 0.0029 Ω , LPAK	Hitachi	HAT2099H
Transistor	Q3	1	PNP, 60 V, 350 mW, SOT-23	Diodes, Inc.	MMBT2907A-7
	Q4	1	NPN, 40 V, 350 mW, SOT-23	Diodes, Inc.	MMBT2222A-7
MOSFET	Q5	1	N-channel, 200 V, 3 A, 0.130 Ω , SO-8	Fairchild	FDS2670S
Resistor	R1, R10	2	Thick film, 10 Ω , \pm 5%, 1/2 W, 2010	Panasonic - ECG	ERJ-12ZYJ100U
	R2, R3, R16	3	Thick film, 10 k Ω , \pm 5%, 1/16 W, 0603	Panasonic - ECG	ERJ-3GEYJ103V
	R4	1	Thick film, 20 Ω , \pm 5%, 1/10 W, 0805	Panasonic - ECG	ERJ-6GEYJ200V
	R5	1	Thick film, 750 Ω , \pm 1%, 1/16 W, 0603	Panasonic - ECG	ERJ-3EKF7500V
	R6	1	Thick film, 499 Ω , \pm 1%, 1/10 W, 0805	Panasonic - ECG	ERJ-6ENF4990V
	R7, R20	2	Thick film, 1.1 k Ω , \pm 5%, 1/16 W, 0603	Panasonic - ECG	ERJ-3GEYJ112V
	R9	1	Thick film, 86.6 k Ω , \pm 5%, 1/16 W, 0603	Panasonic - ECG	ERJ-3EKF8662V
	R11	1	Thick film, 12.1 k Ω , \pm 1%, 1/16 W, 0603	Panasonic - ECG	ERJ-3EKF1212V
	R13	1	Thick film, 909 Ω , \pm 5%, 1/16 W, 0603	Panasonic - ECG	ERJ-3EKF9090V
	R14	1	Thick film, 21.0 k Ω , \pm 1%, 1/16 W, 0603	Panasonic - ECG	ERJ-3EKF2102V
	R15	1	Thick film, 10 Ω , \pm 5%, 1/16 W, 0603	Panasonic - ECG	ERJ-3GEYJ100V
	R17	1	Thick film, 2.10 k Ω , \pm 1%, 1/16 W, 0603	Panasonic - ECG	ERJ-3EKF2101V
	R18	1	Thick film, 6.19 k Ω , \pm 1%, 1/16 W, 0603	Panasonic - ECG	ERJ-3EKF6191V
	R19	1	Thick film, 11.8 k Ω , \pm 1%, 1/16 W, 0603	Panasonic - ECG	ERJ-3EKF1182V
	R21	1	Thick film, 0.56 Ω , \pm 5%, 1 W, 2512	Panasonic - ECG	ERJ-1WRQJR56U
	R22	1	Thick film, 24 Ω , \pm 5%, 1/16 W, 0603	Panasonic - ECG	ERJ-3GEYJ240V
	Transformer	T1	1	70 μ H, RM-5-SMD, RM5	Pulse
Inductor	T2	1	Coupled, 2 μ H, RM5-SMD, RM5	Pulse	PB2118
	U1	1	BiCMOS Current Mode PWM Controller, MICRO8_DGK8	Texas Instruments	UCC38C42DGK
	U2	1	Optoisolator Trans Output, SO-8	Fairchild	MOC207M
	U3	1	Low Voltage Adjustable Shunt Reg, SOT-23-5	Texas Instruments	TLV431AIDBVR

IMPORTANT NOTICE

Texas Instruments Incorporated and its subsidiaries (TI) reserve the right to make corrections, modifications, enhancements, improvements, and other changes to its products and services at any time and to discontinue any product or service without notice. Customers should obtain the latest relevant information before placing orders and should verify that such information is current and complete. All products are sold subject to TI's terms and conditions of sale supplied at the time of order acknowledgment.

TI warrants performance of its hardware products to the specifications applicable at the time of sale in accordance with TI's standard warranty. Testing and other quality control techniques are used to the extent TI deems necessary to support this warranty. Except where mandated by government requirements, testing of all parameters of each product is not necessarily performed.

TI assumes no liability for applications assistance or customer product design. Customers are responsible for their products and applications using TI components. To minimize the risks associated with customer products and applications, customers should provide adequate design and operating safeguards.

TI does not warrant or represent that any license, either express or implied, is granted under any TI patent right, copyright, mask work right, or other TI intellectual property right relating to any combination, machine, or process in which TI products or services are used. Information published by TI regarding third-party products or services does not constitute a license from TI to use such products or services or a warranty or endorsement thereof. Use of such information may require a license from a third party under the patents or other intellectual property of the third party, or a license from TI under the patents or other intellectual property of TI.

Reproduction of information in TI data books or data sheets is permissible only if reproduction is without alteration and is accompanied by all associated warranties, conditions, limitations, and notices. Reproduction of this information with alteration is an unfair and deceptive business practice. TI is not responsible or liable for such altered documentation.

Resale of TI products or services with statements different from or beyond the parameters stated by TI for that product or service voids all express and any implied warranties for the associated TI product or service and is an unfair and deceptive business practice. TI is not responsible or liable for any such statements.

Mailing Address:

Texas Instruments
Post Office Box 655303
Dallas, Texas 75265