

# ATX Specification

Version 2.1

---

## **IMPORTANT INFORMATION AND DISCLAIMERS**

1. INTEL CORPORATION MAKES NO WARRANTIES WITH REGARD TO THIS ATX SPECIFICATION (“SPECIFICATION”), AND IN PARTICULAR DOES NOT WARRANT OR REPRESENT THAT THIS SPECIFICATION OR ANY PRODUCTS MADE IN CONFORMANCE WITH IT WILL WORK IN THE INTENDED MANNER. NOR DOES INTEL ASSUME RESPONSIBILITY FOR ANY ERRORS THAT THE SPECIFICATION MAY CONTAIN OR HAVE ANY LIABILITIES OR OBLIGATIONS FOR DAMAGES INCLUDING, BUT NOT LIMITED TO, SPECIAL, INCIDENTAL, INDIRECT, PUNITIVE, OR CONSEQUENTIAL DAMAGES WHETHER ARISING FROM OR IN CONNECTION WITH THE USE OF THIS SPECIFICATION IN ANY WAY.

2. NO REPRESENTATIONS OR WARRANTIES ARE MADE THAT ANY PRODUCT BASED IN WHOLE OR IN PART ON THE ABOVE SPECIFICATION WILL BE FREE FROM DEFECTS OR SAFE FOR USE FOR ITS INTENDED PURPOSE. ANY PERSON MAKING, USING OR SELLING SUCH PRODUCT DOES SO AT HIS OR HER OWN RISK.

3. THE USER OF THIS SPECIFICATION HEREBY EXPRESSLY ACKNOWLEDGES THAT THE SPECIFICATION IS PROVIDED AS IS, AND THAT INTEL CORPORATION MAKES NO REPRESENTATIONS, EXTENDS NO WARRANTIES OF ANY KIND, EITHER EXPRESS OR IMPLIED, ORAL OR WRITTEN, INCLUDING ANY WARRANTY OF MERCHANTABILITY OR FITNESS FOR A PARTICULAR PURPOSE, OR WARRANTY OR REPRESENTATION THAT THE SPECIFICATION OR ANY PRODUCT OR TECHNOLOGY UTILIZING THE SPECIFICATION OR ANY SUBSET OF THE SPECIFICATION WILL BE FREE FROM ANY CLAIMS OF INFRINGEMENT OF ANY INTELLECTUAL PROPERTY, INCLUDING PATENTS, COPYRIGHT AND TRADE SECRETS NOR DOES INTEL ASSUME ANY OTHER RESPONSIBILITIES WHATSOEVER WITH RESPECT TO THE SPECIFICATION OR SUCH PRODUCTS.

4. A SOFTWARE LICENSE IS HEREBY GRANTED TO REPRODUCE THIS SPECIFICATION FOR ANY PURPOSE PROVIDED THIS “IMPORTANT INFORMATION AND DISCLAIMERS” SECTION (PARAGRAPHS 1-4) IS PROVIDED IN WHOLE. NO OTHER LICENSE, EXPRESS OR IMPLIED, BY ESTOPPEL OR OTHERWISE, TO ANY OTHER INTELLECTUAL PROPERTY RIGHTS IS GRANTED HEREIN.

Copyright © 1996, 1997, 1998, 2002 Intel Corporation. All rights reserved.

Version 2.1, June 2002

† Third-party brands and names are the property of their respective owners.

# Revision History

---

## Changes from Version 2.03 to Version 2.1

Global change—Removed references to Mini-ATX

Section 2—Replace existing text with new text that adds requirement for ATX12V connector; substitute revised Figure 1

Section 3.3—Add ATX12V power connector information to Table 3

Section 3.3.2—Replace existing text with new text that includes the 12V requirement for processor voltage regulators

Section 3.4—Moved text in Section 3.4 under a new subheading, 3.4.1. Added subheading, 3.4.2, to specify secondary side height constraints. Revised Figure 7 to reflect an increase in the maximum component height restriction. Zones C, D, and E formerly specified three different height restrictions. This revision replaces those three zones (C, D, and E) with one maximum component height restriction zone (C) for the entire region. Added two sentences at the end of the note that follows Figure 7.

Section 4—Replace existing text with new text that adds the 12V connector and a reference to the ATX/ATX12V Power Supply Design Guide

Section 4.2—Add references to the ATX12V connector; substitute revised Figure 10

Section 4.4—Add new Table 10 that lists wire color code for ATX12V power supplies

Section 6—Update Web site URL for ATX information and document downloading

## Changes from Version 2.02 to Version 2.03

Replaced seven occurrences of the erroneous name “microATX” with the correct name “Mini-ATX.” The error was introduced accidentally in Version 2.02. The Mini-ATX form factor is 11.2" x 8.2" (284mm x 208mm; the Mini-ATX form factor referred to in this *ATX Specification* is NOT the same as the microATX form factor, which is described in a separate specification.

## Changes from Version 2.01 to Version 2.02

Section 3.3.5—Replaced Figures 4 and 5.

Section 4.2.1—Added new section to define Aux Power Connector; renumbered the subsequent sections, figures, and tables accordingly.

Section 4.2.2.3—Replaced Figure 11 to better explain the power supply timing.

Section 4.2.3—Corrected two values in Table 7, Voltage Tolerances: -5VDC and -12VDC should comply to  $\pm 10\%$ , not  $\pm 5\%$ . This change was made to match the newly released *Intel ATX Power Supply Design Guide*, Version 0.9.

Section 4.4—Corrected Table 9; the 1394R signal is carried on Pin 4, and Pin 6 is Reserved. This matches the information shown in Figure 12.

Section 6—Added section to provide the Internet location of the ATX home page, for access to documents with information beyond the requirements of this ATX Specification.

## Changes from Version 2.0 to Version 2.01

Section 2—Updated Figure 1 to reflect recommendations implemented with Version 2.0.

Section 3.2—Modified Figure 2 to clarify motherboard mount requirements.

Section 3.3—Updated table of requirements to reflect changes in the section outlined below.

Section 3.3.5—Rewrote text to clarify requirements.

*Continued*

Section 3.3.5—Reduced keepout zone requirement to 0.1" (2.5 mm). This change was based on feedback from chassis manufacturers and is the most significant requirement change with respect to the chassis.

Section 3.3.5—Added recommendation to avoid paint within the keepout zone.

Section 3.3.5—Replaced Figure 4 to clarify chassis I/O aperture requirements. Tolerances were added to dimensions.

Section 3.3.5—Changed Figure 5 to define connector placement limitations on the motherboard. This is a new recommendation for motherboard designers to ensure clearance between the chassis and motherboard connectors for the I/O shield.

Section 3.3.5—Modified Figure 6 to remove redundant dimensions, and removed Figure 7 completely.

Section 4.3.2—Completely redefined FanC signal description, and removed Figure 15 completely.

Minor edits were made throughout the document to improve readability and to correct minor typographical or grammatical errors.

### **Changes from Version 1.1 to Version 2.0**

Section 3.2—Changed the optional mounting hole to a required hole in chassis implementations. Changed a previously required mounting hole to “not needed.”

Section 3.3.5—Added information and drawing to clarify I/O aperture requirements. Added corner radius information to the specification for clarity

Section 3.4—Changed height restrictions to facilitate future processor and onboard technologies.

Section 4—Added an explanation of the intent regarding the direction of air travel for cooling. Removed the external fan shown on the drawing of a suggested ATX power supply. Added a caution about external power supply fans. Added comments and drawings for duct mounting.

Section 4.2—Added explanations for PS\_ON#, PWR\_OK, 5VSB power supply lines. The 3.3VDC power rail and soft-power control signals are being changed to required.

Section 4.3—Added optional power connector for fan control, fan monitor, IEEE-1394 voltages, and remote 3.3 volt sensing.

Section 4.4—Added a section to give a suggested color coding for power supply wiring.

Section 4.5—Added a section suggesting a venting solution for power supplies.

Section 5—Added chassis considerations.

Added tables throughout the specification for clarification and easy reference of recommended and required features.

# Contents

---

<b>1. Executive Summary .....</b>	<b>7</b>
<b>2. ATX Form-factor Overview .....</b>	<b>8</b>
<b>3. Layout .....</b>	<b>9</b>
3.1 Board Size.....	9
3.2 Mounting Hole Placement .....	9
3.3 Connector Placement .....	11
3.3.1 Expansion slots .....	11
3.3.2 Power Input.....	13
3.3.3 Disk I/O .....	13
3.3.4 Front Panel I/O.....	13
3.3.5 Back Panel I/O .....	13
3.3.6 Memory Sockets .....	16
3.3.7 Processor .....	16
3.4 Height Constraints.....	16
3.4.1 Primary (Component) Side Height Constraints.....	16
3.4.2 Secondary (Bottom/Solder) Side Height Constraints.....	18
<b>4. Power Delivery .....</b>	<b>19</b>
4.1 Power Supply Connectors.....	19
4.1.1 Aux Power Connector for 250 W and 300 W Configurations .....	20
4.1.2 2x2 Connector.....	20
4.1.3 Power Signal Control Definitions.....	20
4.1.4 Voltage Tolerances .....	21
4.2 Optional Power Connector .....	21
4.2.1 FanM Signal .....	22
4.2.2 FanC Signal .....	22
4.2.3 3.3 V Sense Line.....	23
4.2.4 1394 V Pin.....	23
4.2.5 1394R Pin .....	23
<b>5. Other ATX Chassis Considerations.....</b>	<b>24</b>
5.1 Venting .....	24
5.2 Power Supply Mounting .....	24
<b>6. Additional Information .....</b>	<b>24</b>

## Figures

Figure 1. Summary of ATX Chassis Features .....	8
Figure 2. ATX and microATX Form Factor Mounting Holes .....	10
Figure 3. Sample ATX Layout Diagram .....	12
Figure 4. Chassis Back Panel I/O Aperture Requirements.....	14
Figure 5. Motherboard I/O Connector Zone Recommendation .....	15
Figure 6. Example Multimedia I/O Back Panel .....	15
Figure 7. ATX Motherboard Maximum Component Height Restrictions.....	17
Figure 10. ATX Power Supply Connector Configuration.....	19
Figure 9: 2x2 Connector Configuration .....	20
Figure 12. Optional Power Supply Connector Configuration .....	22
Figure 13. Simple Implementation of a Fan Monitor Circuit.....	22

## Tables

Table 1. ATX Feature Summary .....	7
Table 2. Motherboard Mounting Hole Locations .....	9
Table 3. Connector Locations .....	11
Table 4. Height Constraints .....	16
Table 5. Aux Power Connector for High 3.3V or 5V Current Configurations .....	20
Table 6. Voltage Tolerances .....	21

# 1. Executive Summary

---

ATX was developed as an evolution of the Baby-AT form factor and was defined to address four major areas of improvement: enhanced ease-of-use, better support for current and future I/O, better support for current and future processor technology, and reduced total system cost.

ATX combines the best functionality from the form factors that dominated the computer industry in the early 1990s: the high integration of LPX and the expandability of Baby-AT. The ATX form factor is essentially a Baby AT motherboard rotated 90 degrees within the chassis enclosure and providing a new mounting configuration for the power supply. The processor is relocated away from the expansion slots, allowing them all to hold full length add-in cards. The longer side of the board is used to host more on-board I/O. Table 1 summarizes the ATX features.

A change to the system form factor is ultimately of little benefit if it does not reduce overall system cost. ATX has achieved cost reduction in a number of ways:

- Material cost of cables and add-in cards is reduced because more I/O can be integrated down onto the board and because the hard drive and floppy connectors can be better positioned, allowing the use of shorter cables.
- Another benefit of integrated I/O down is the potential for lower EMI emissions with the removal of serial and parallel cables that can act like antennas.
- Manufacturing time and inventory holding costs are reduced because the number of cables in the system is reduced.
- Video-playback enhanced graphics and audio, the main hardware building blocks to support multimedia, are becoming a standard on many PCs; at the entry level, these features are quickly becoming a commodity. To reduce cost in a highly dollar-sensitive market segment, it makes sense to migrate these features down to the motherboard itself.

The ATX specification is written as an open specification for the industry, designed to add value to PC architecture.

**Table 1. ATX Feature Summary**

<b>Feature</b>	<b>Benefit</b>
Double height flexible I/O panel allows higher integration	Lower system cost Fewer cables Improved reliability Shorter assembly time Support for connectivity and I/O standards like USB, TV in/out, ISDN, etc. Integrated graphics allows use of unified frame buffer architecture
Relocated drive I/O means shorter cables	Reduced cost Support for faster drives such as PIO Mode 4/5 IDE drives
Relocated processor and memory	All full-length expansion slots Ease of use, upgrading the processor Ease of use, upgrading memory Ease of use, adding cards Relocated processor allows easier use of bulk capacitance and voltage regulation circuitry

## 2. ATX Form-factor Overview

---

The ATX form factor allows for processor relocation away from the expansion slots, allowing the longer side of the board to be used to host more on-board I/O. For processor voltage regulators that have been designed for 12V input, an additional 12V power connector must be added. ATX power supplies with the required 12V current and associated connector are designated "ATX12V". The ATX12V mating connector is shown in Figure 10. Details on the power supply can be found in the *ATX/ATX12V Power Supply Design Guide* (see Section 6 for URL from which the document can be downloaded).

---

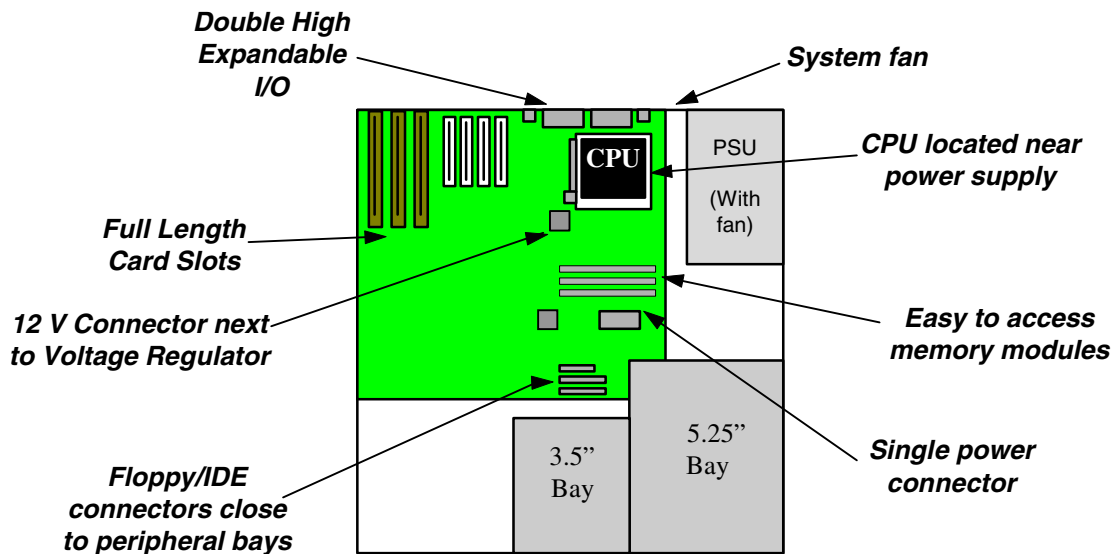

Figure 1. Summary of ATX Chassis Features



## 3. Layout

---

The following sections describe the mechanical specification of the ATX form factor motherboard, including physical size, mounting hole placement, connector placement, and component height constraints.

### 3.1 Board Size

A full size ATX board is 12" wide by 9.6" deep (305mm x 244mm). This allows many ATX form factor chassis to accept microATX boards as well.

### 3.2 Mounting Hole Placement

**Table 2. Motherboard Mounting Hole Locations**

Feature	Status	Comment
Motherboard mounting hole locations	Required	See Figure 2 for an overview and Figure 3 for exact locations. All ATX board mounting locations shown should be implemented for full ATX 2.1 compliance.

Where possible, the ATX mounting holes line up with mounting holes used for microATX boards. Three holes have been defined to provide mechanical support along the front edge of the full size ATX board.

- Figure 2 shows the relative outlines of the ATX and microATX boards. This figure uses letter callouts to show the general location of the mounting holes for the ATX and microATX form factors. The accompanying table indicates which holes are required for each form factor.
- Figure 3 shows the exact location (dimensions) of the mounting holes for ATX boards.

#### **Must be used**

All ATX board mounting locations listed in the table in Figure 2 should be implemented for chassis assemblies to achieve full ATX 2.1 compliance and to provide proper support for the board in these areas.

The hole at F in Figure 2 (upper right corner of the ATX board) must be implemented in all ATX 2.1-compliant chassis assemblies to accommodate boards requiring this mounting hole. This hole was labeled optional in the ATX 1.1 specification. Note that changing this mounting location from optional to required may not accommodate all ATX 1.0- and 1.1-compliant motherboards. To accommodate these motherboards, a removable standoff may be used. All ATX 2.1-compliant motherboards should implement this mounting location or allow for a standoff in this area by implementing a component and trace keepout.

#### **No longer used**

The hole at B in Figure 2 was previously required along the rear edge of the board. This location is not required for ATX designs. If it is desired to implement a board mount in this area, a removable standoff should be used to avoid problems with boards that do not use this mounting location.

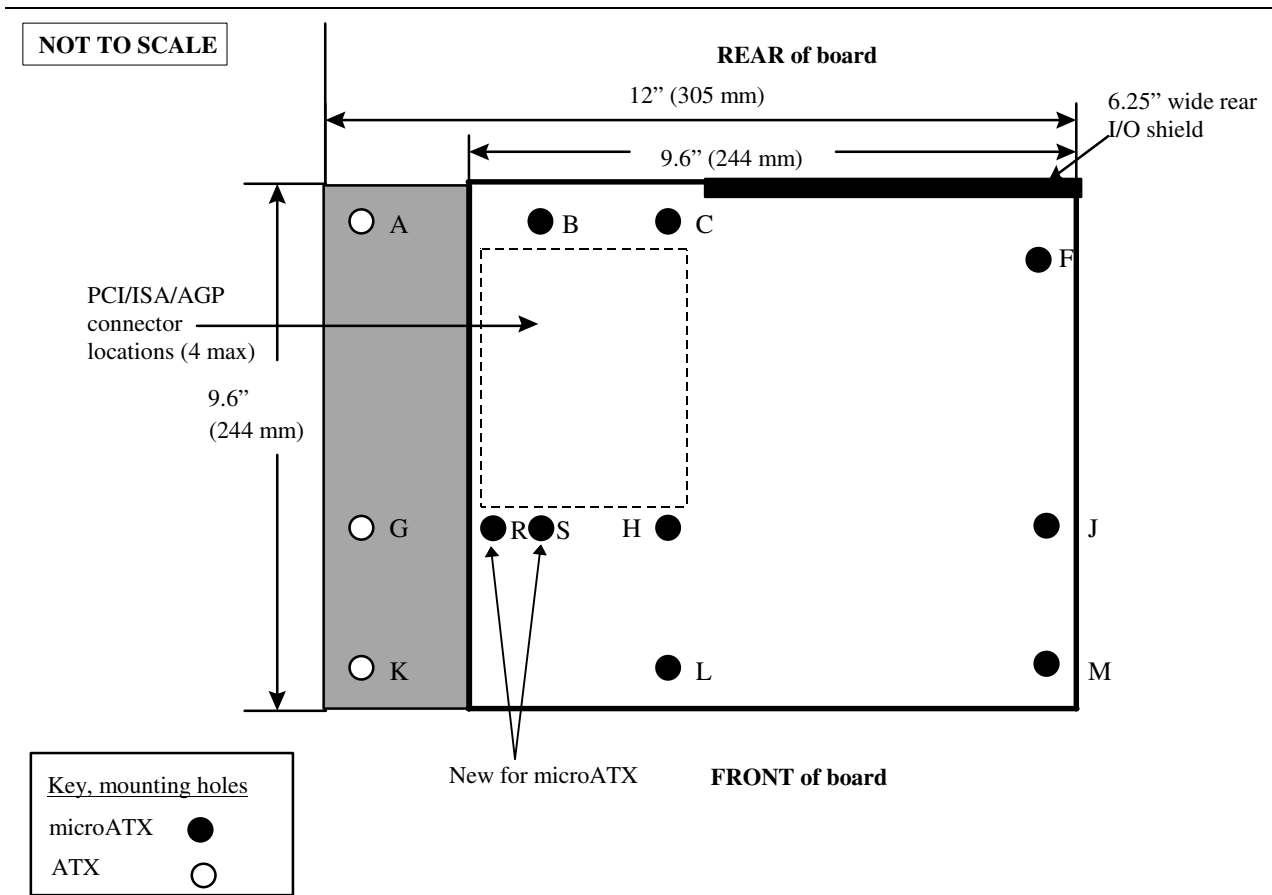

Form factor	Mounting hole locations	Notes
ATX	A, C, F, G, H, J, K, L, M	Hole F must be implemented in all ATX 2.1-compliant chassis assemblies; it was optional in the ATX 1.1 specification.
microATX	B, C, F, H, J, L, M, R, S	Holes R and S are added for microATX form factor. Hole B was defined in Full AT format

**Figure 2. ATX and microATX Form Factor Mounting Holes**

## 3.3 Connector Placement

Table 3 lists connector locations. Figure 3 clearly defines the location of the PCI and ISA connectors as well as the allowable placement area for I/O connectors on the back panel. The specification provides recommendations, but the exact locations of other connectors are left to the judgment of the motherboard designer working in conjunction with the system integrator.

**Table 3. Connector Locations**

Feature	Status	Comment
ATX12V power connector	Required for 12V voltage regulator designs	See Figure 10
Back panel I/O aperture size and location	Required	See Figure 4.
Back panel I/O connector arrangement	Optional	See Figure 6 for example.
Back panel I/O connector zone	Recommended	See Figure 5.
Disk I/O connector location	Recommended	Front edge of board, near drive bays.
Front panel I/O connector locations	Recommended	Front edge of board, right of expansion slots.
Memory module connector location	Recommended	Between processor and expansion slots, or between processor and disk I/O connectors.
Optional Power connector pinout	Recommended	See Figure 12 (Optional power supply connector configuration).
Expansion Slot connector locations	Required	See Figure 3.
Power input connector location	Recommended	Right edge of board, near processor.
Power input connector pinout	Required	See Figure 10 (ATX power supply connector configuration).
Processor location	Recommended	Right of expansion slots, front of back panel I/O connectors.

### 3.3.1 Expansion slots

The ATX form factor supports up to seven expansion slots. These slots may be any combination of ISA, PCI, shared ISA/PCI, AGP, CNR, or shared CNR/PCI. Figure 3 shows a combination of the three ISA slots, two PCI slots, one shared ISA/PCI slot, and one AGP slot. The location of pin 1 is defined for each of the connectors. If a combination other than that shown in Figure 3 is desired, motherboard designers should extrapolate the location of pin one on each of the connectors. The slot spacing must remain constant. To allow all add-in cards to be full length, it is recommended that the height of any board component located to the left of the right edge of the seventh slot (plus clearance for the board components) be less than 0.6 inches (15.2mm). For more details on component height constraints, see Section 3.4. For extra support during add-in card insertion, it is suggested that mechanical support be implemented under expansion slots through use of a device such as a bumper.

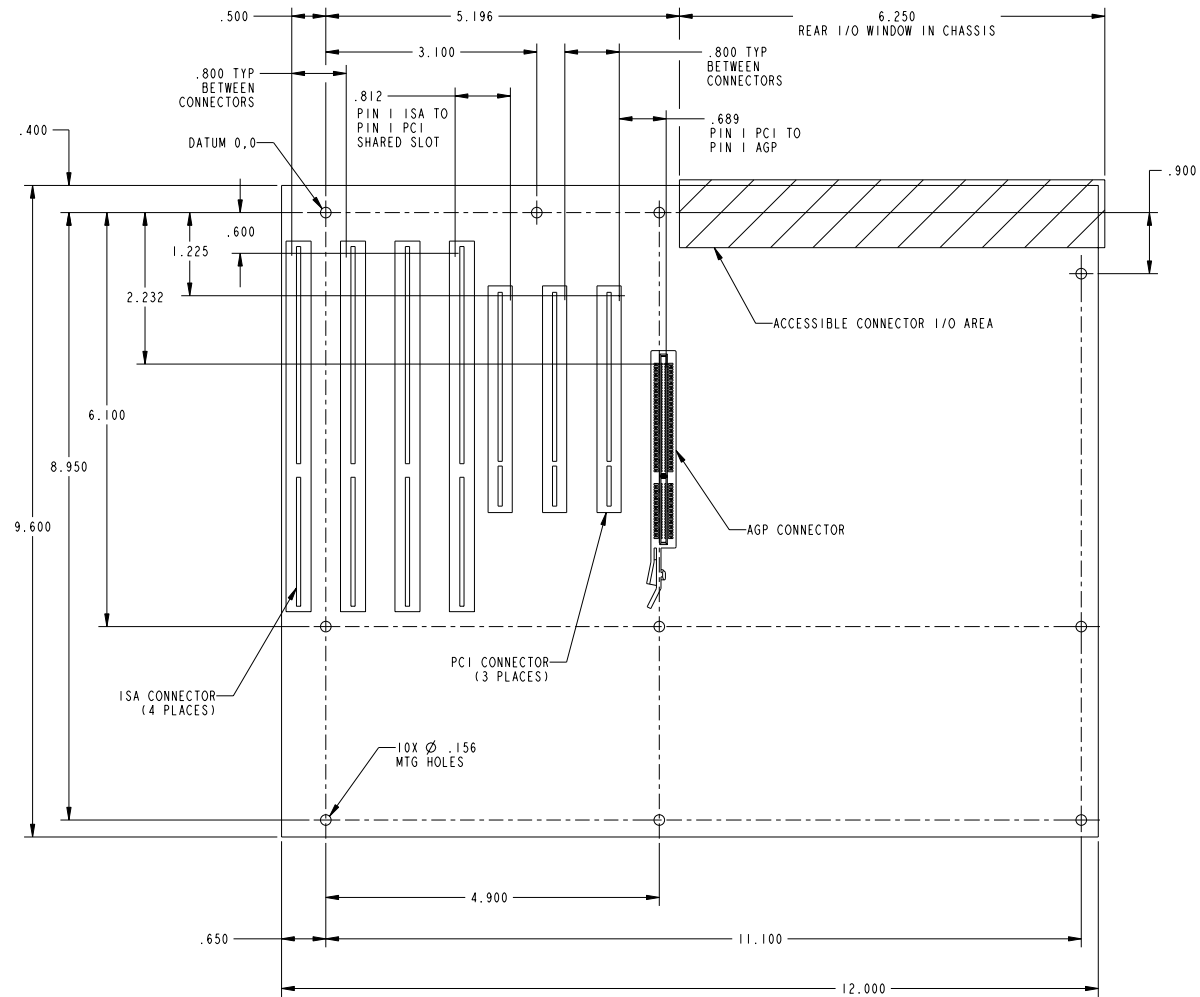

**Figure 3. Sample ATX Layout Diagram**

(all dimensions shown in inches)

### 3.3.2 Power Input

Power distribution trends are driving a change in the board power input connectors. As processors become faster and more highly integrated, more current is required. To reduce power distribution loss, board manufacturers are moving toward 12V power distribution. To facilitate 12V distribution to the processor voltage regulator, a 2x2 connector will be required on these systems. The power supply connector is described in Section 4.1.2.

The exact locations of the power connectors are not specified. It is recommended that the main connector be placed along the right edge of the board, taking into consideration the location of the processor, core logic, and clearance for the peripheral bays. The ATX12V power connector should be placed as close as possible to the input of the processor voltage regulator. Locating the ATX12V power connector near the voltage regulator will help to ensure clean power.

### 3.3.3 Disk I/O

The exact locations of the floppy, IDE, and/or SCSI I/O connectors are not specified. It is recommended that they be placed along the front edge of the board to the right of the expansion slots. When placing connectors, the designer should keep in mind that proper clearance must be provided for the chassis peripheral bays.

### 3.3.4 Front Panel I/O

The exact location of the front panel I/O connector is not specified. It is recommended that it be placed along the front edge of the board to the right of the expansion slots. When placing the connector, the designer should keep in mind that proper clearance must be provided for the chassis peripheral bays. Locating the front panel I/O connector along the left edge of the board is not recommended due to limited clearance with a full length add-in card. Locating it along the front edge of the board under the expansion slots using a right angle header may be acceptable, provided that clearance for the add-in cards and mechanical retention of the mating connector is properly accounted for.

### 3.3.5 Back Panel I/O

Toward the rear of the chassis, ATX defines a stacked I/O area that is 6.25" (158.75mm) wide by 1.75" (44.45mm) tall. This area allows the use of stacked connectors on the motherboard to maximize the amount of I/O space available.

As shown in Figure 4, the bottom of the back panel opening is located 0.150" (3.81mm) below the top of a typical, 0.062" (1.57 mm) thick motherboard. Also, a 0.1" (2.5 mm) keepout zone has been defined around the perimeter of the cutout area, on both the inside and outside surfaces of the chassis back panel. This required keepout zone provides a reserved space that can be used to clip a chassis-independent I/O shield to the chassis back panel. No slots, tabs, notches, or other topographical features should be placed within the keepout zone. If a feature violates the keepout zone, the chassis loses the opportunity to support an I/O shield that can be designed to fit all ATX chassis that meet the specifications listed below and detailed in Figures 4 and 5. For best EMI attenuation performance, paint should not be applied within the keepout area as it can prevent proper grounding of the I/O shield. Also, motherboard connector placement must be limited as shown in Figure 5 to allow enough clearance between the connectors and chassis opening for the I/O shield structure.

- Nominal cutout size = 6.25" (158.75mm) by 1.75" (44.45mm). See Figure 4 for tolerances.
- Distance from top of a typical 0.062" (1.57 mm) motherboard to bottom of I/O cutout hole = 0.150" (3.81mm) (Figure 4).
- Allowable thickness of a chassis back panel that the I/O shield can clip into is in the range 0.037" (0.94mm) to 0.052" (1.32mm) (Figure 4).

- The corners of the I/O aperture can be rounded to a maximum radius of .039" (0.99mm) (Figure 4). This allowable rounding of the corners helps case manufacturers extend the life of their hard tooling while still complying with the specification.
- The 0.1" (2.5mm) keepout zone around the I/O aperture area is required in an ATX 2.1-compliant chassis (Figure 4). This allows ATX 2.1-compliant I/O shields to fit into ATX 1.1 or 2.1-compliant cases. The keepout area is needed for the shield attachment points. Avoid paint application in this area.
- The face of all I/O connectors should be placed 0.445" (11.30mm) from the reference datum and remain within the zone defined in Figure 5.
- The I/O aperture should be a simple cutout of the chassis back panel. Recessing the I/O aperture will prevent the case from accepting ATX 2.1-compliant I/O shields.

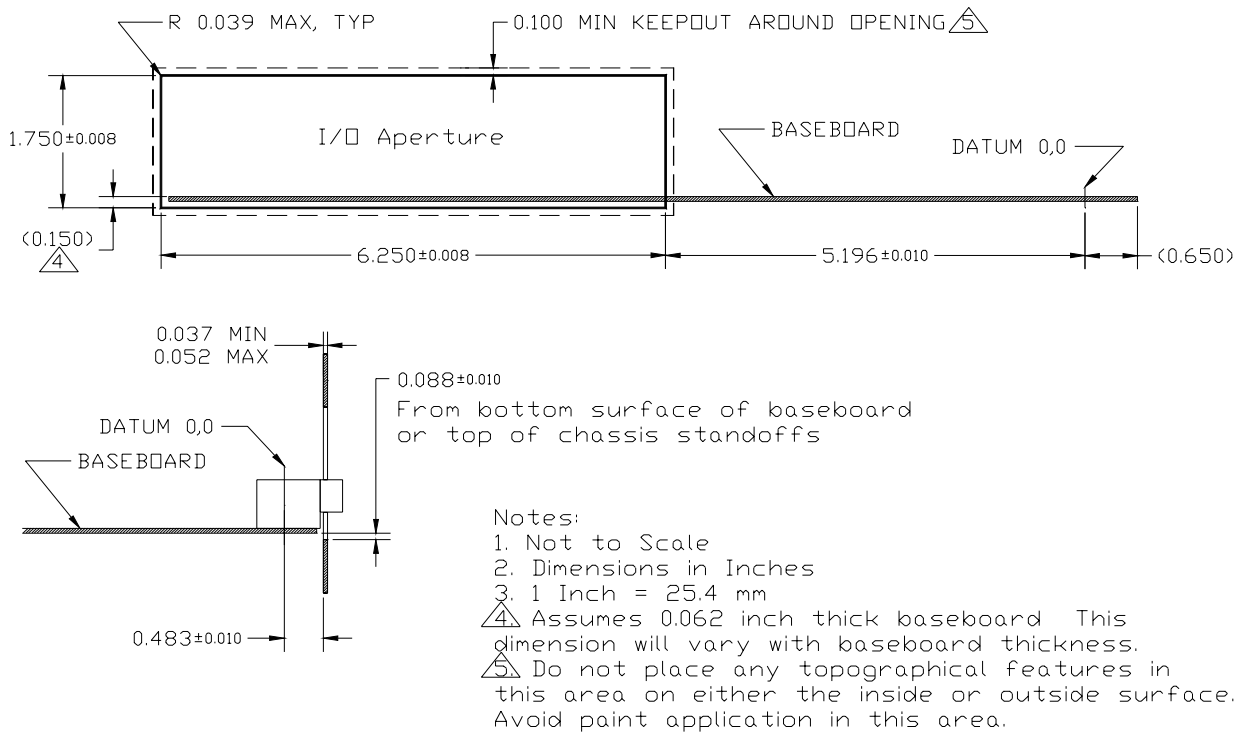
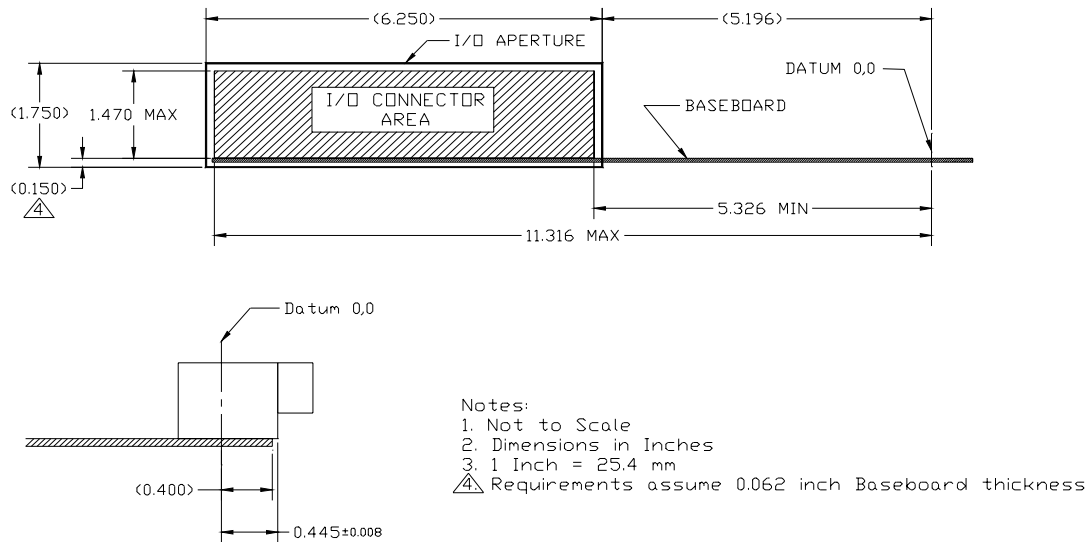

**Figure 4. Chassis Back Panel I/O Aperture Requirements**

(rear and side view—see Figure 3 for datum location)

Note: The term “baseboard” used in the figure above and other figures is equivalent to the term “motherboard” used in the text throughout.

Figure 5 specifies the I/O connector zone. Compliance with this recommendation is necessary to ensure enough clearance between the chassis aperture and motherboard connectors for the I/O shield structure. This recommendation may be waived if the shield provided with the motherboard requires less than the recommended clearance. To retain maximum flexibility, the exact positioning of connectors within the I/O connector zone is left to the discretion of the motherboard designer.



**Figure 5. Motherboard I/O Connector Zone Recommendation**

(rear and side view—see Figure 3 for datum location)

Figure 6 shows an example of a multimedia I/O panel, featuring stacked keyboard and mouse connectors, four stacked USB connectors – two on either side of the serial port, parallel port, and VGA connector, a LAN connector, and stacked audio jacks. Other connectors, such as modem or ISDN, could be added if the manufacturer desired. This layout is only an example—the ATX form factor allows complete flexibility in the layout of back panel I/O.

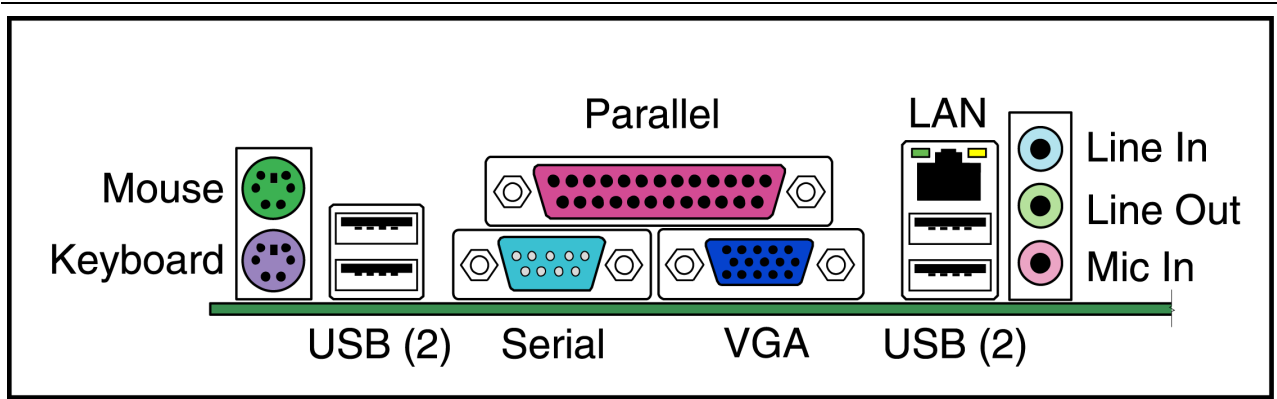

**Figure 6. Example Multimedia I/O Back Panel**

### 3.3.6 Memory Sockets

The exact location of the memory sockets is not rigidly specified. Ideally, the sockets should be located to the right of the seventh expansion slot and far enough toward the back edge of the board to clear the chassis peripheral bays. This will enable easy upgrade by the end user. The exact location of the sockets will be dictated by the processor and core logic placement requirements. Two of the most likely locations are:

- Placed rear to front between the processor and the seventh expansion slot, or
- Placed left to right between the processor and the front edge of the board.

### 3.3.7 Processor

The exact location of the processor is not specified. It is recommended that it be located behind the external I/O connectors and to the right of the seventh expansion slot, so that it receives sufficient cooling. It may be cooled from a combination of the system fan, the fan located in the power supply, an active heatsink (fan attached to the processor), and/or normal airflow through the chassis. The exact method will depend on the specific processor cooling requirements.

## 3.4 Height Constraints

### 3.4.1 Primary (Component) Side Height Constraints

One of the major advantages of the ATX form factor is its accessibility and ease of expansion. Table 4 lists the status of height constraints for specific areas. Figure 7 shows the required **maximum component** height constraints for the components on the PC board. For full compliance with ATX 2.1, the motherboard should not encroach into these areas, which are reserved for ATX 2.1-compliant power supplies, standard peripherals, or chassis features. Similarly, ATX 2.1-compliant power supplies, peripherals, and chassis features should not extend into the motherboard component area.

 **Note**

All keepout areas are now required for chassis implementations that are to be ATX 2.1-compliant. Of particular note is the revision in the component height restriction of Areas A and C. Motherboard components in Area A may now extend to 2.80" high, whereas in V1.1 of the specification, maximum component height in Area A was limited to 2.20". Area C now encompasses the former Areas C, D, and E to allow for components up to 1.5" in the entire area.

**Table 4. Height Constraints**

Feature	Status	Comment
ATX motherboard maximum component heights	Required	See Figure 7.
ATX chassis keepout in Area A	Required	3.0 inches. See Figure 7.
ATX chassis keepout in Area A	Recommended	3.5 inches. See Figure 7.

Regarding the chassis keepout for Area A:

- Required: A clearance above the motherboard **must** be 3.0" to facilitate dynamic considerations of components in this area on the PC board.
- Recommended: A clearance of 3.5" is **preferred** to facilitate cooling solutions that require ducting.

Careful placement of peripherals, power supply, and chassis features is required to maintain strict compliance to the ATX 2.1 specification.



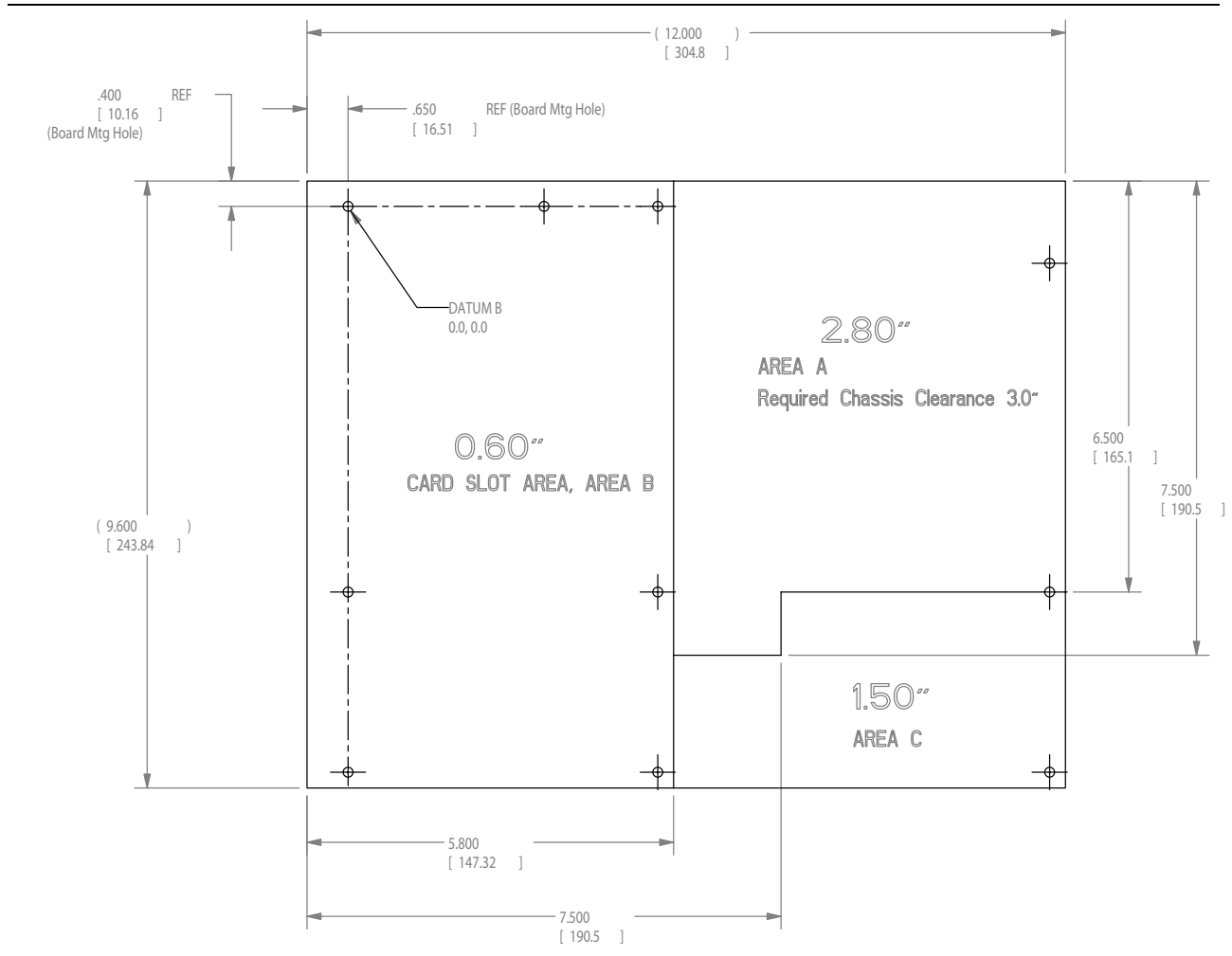

**Figure 7. ATX Motherboard Maximum Component Height Restrictions**

(all dimensions in inches)

**Notes:**

- The 2.80" height restriction in Area A applies to the PC board component height. The required clearance for the chassis in this area is 3.0". The difference in these heights is related to the need to accommodate dynamic excursion considerations for shipping. The recommended clearance for the chassis in this area is 3.5" to facilitate alternative processor cooling solutions.
- The component height requirement assumes a motherboard thickness of 0.062" (1.57 mm). The maximum height specified for Area C is intended to avoid interference between motherboard components and the chassis structure and to provide backward-compatibility with ATX 2.03 or higher.
- Area C was changed to match the same area on the microATX form factor. The revised area is backward compatible with previous ATX designs.
- When designing an ATX motherboard, attention should also be paid to keepouts specific to the specifications for the type of add-in card slots being integrated into the motherboard, which may have additional requirements for motherboard component heights. Example is the PCI and AGP add-in card specifications which require a maximum component height in the area between the card connector and the rear panel that is less than the Area B component heights.

### 3.4.2 Secondary (Bottom/Solder) Side Height Constraints

Required secondary (bottom) side motherboard height constraints for all areas (A-C, as shown in Figure 7) are defined as follows (measured from the bottom planar surface of the motherboard PCB):

- $\leq 0.010''$  – Mounting hole standoff areas – no components. Restriction applies within  $0.400''$  square area centered on each required mounting hole location defined in Section 3.2. Nominal allowance is provided only to accommodate slight reflow solder excess.
- $\leq 0.098''$  – All board circuit components (including leads) that are electrically conductive and intolerant of direct connection to chassis ground (e.g., through-hole leads, surface mount resistors)
- $\leq 0.120''$  – Board components that are non-conductive or otherwise tolerant of direct connection to chassis ground (e.g., connector guide/stake pins)
- $\leq 0.200''$  – Devices attached to the motherboard for the sole purpose of structural retention or stiffening

A chassis and its related elements (e.g., stiffening ribs, base pan, structural supports fasteners, etc.) must allow  $\geq 0.250''$  clearance to the bottom planar surface of the motherboard PCB. This does not including mounting hole standoffs, which may extend to and contact the PCB at the mounting holes within the prescribed  $0.400''$ -square areas.

# 4. Power Delivery

The ATX form factor allows different configurations of chassis and power supplies. Several standard power supplies exist including the ATX12V, SFX12V, and TFX12V. Design Guides are published to assist in integration of the power supply into the ATX form factor (see Section 6 for URL).

This section defines the basic requirements for system power supplies.

## 4.1 Power Supply Connectors

Figure 10 shows the connector pinouts for the main ATX power connector and the ATX12V connector. The main ATX power board-mounted header may be implemented with a Molex 39-29-9202 or equivalent. This mates with the power supply connector, Molex 39-01-2200 or equivalent. All signals and power rails on the main power connector are required to be implemented.

The ATX 12V board-mounted header may be implemented with a Molex 39-29-9042 or equivalent. This mates with the power supply connector, Molex 39-01-2040 or equivalent. Additional information on the ATX12V power supply can be found in the *ATX/ATX12V Power Supply Design Guide* (see Section 6 for URL).

During power-up and power-down transitions, it is recommended that the 3.3VDC rails always be held at a lower potential than the +5VDC rails. This allows for improved reliability of motherboard designs at a reduced cost.

Proper implementation of PS\_ON#, 5VSB, and PWR\_OK is **required** for an ATX 2.1-compliant power supply.

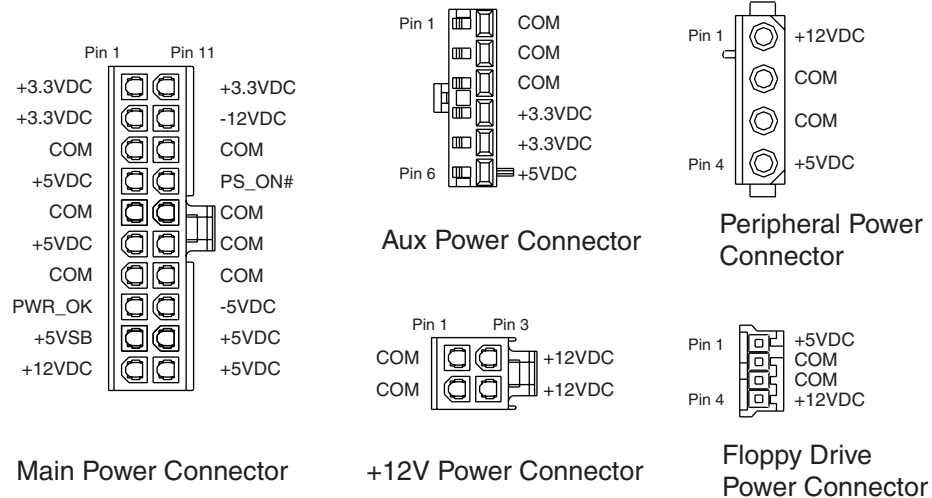

conns990825a

**Figure 10. ATX Power Supply Connector Configuration**

### 4.1.1 Aux Power Connector for 250 W and 300 W Configurations

It is recommended that motherboards requiring 3.3V current over 18 A or +5V current over 30 A implement an Aux Power Connector.

**Table 5. Aux Power Connector for High 3.3V or 5V Current Configurations**

Molex 90331-0010 keyed pin 6 or equivalent		
Pin	Signal	16 AWG Wire
1	COM	Black
2	COM	Black
3	COM	Black
4	3.3 V	Orange
5	3.3 V	Orange
6	5 V	Red

### 4.1.2 2x2 Connector

In addition to the 20-pin main connector, a 2x2 connector (shown in Figure 9) is utilized for +12 V power signals for the processor voltage regulator. For detailed information regarding the power supply or connectors for the microATX form factor, refer to the *ATX/ATX12V Power Supply Design Guide*.

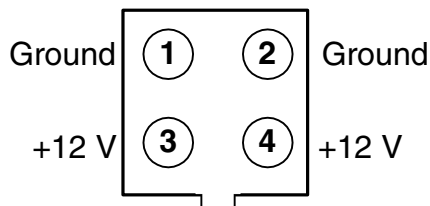

**Figure 9: 2x2 Connector Configuration**

### 4.1.3 Power Signal Control Definitions

#### 4.1.3.1 PS\_ON#

PS\_ON# is an active low signal that turns on all of the main power rails including 3.3VDC, 5VDC, -5VDC, 12VDC, and -12VDC power rails. When this signal is held high by the PC board or left open circuited, outputs of the power rails should not deliver current and should be held at a zero potential with respect to ground. Power should be delivered to the rails only if the PS\_ON# signal is held at ground potential. This signal should be held at +5VDC by a pullup resistor internal to the power supply.

#### 4.1.3.2 5VSB

5VSB is a standby voltage that may be used to power circuits that require power input during the powered-down state of the power rails. This power may be used to operate circuits such as soft power control. It is recommended that the 5VSB line be capable of delivering 2 A. This current allows the implementation of features such as Wake on LAN technology in accordance with IAPC (see <http://developer.intel.com/technology/iapc/index.htm> for more information).

### 4.1.3.3 PWR\_OK

PWR\_OK is a power good signal and should be asserted high by the power supply to indicate that the +5VDC and +3.3VDC outputs are above the undervoltage thresholds of the power supply. When this signal is asserted high, there should be sufficient energy stored by the converter to guarantee continuous power operation within specification. Conversely, when the output voltages fall below the undervoltage threshold, or when mains power has been removed for a time sufficiently long so that power supply operation is no longer guaranteed, PWR\_OK should be de-asserted to a low state. The recommended electrical and timing characteristics of the PWR\_OK signal are provided in the *ATX/ATX12V Power Supply Design Guide*.

Motherboards should be designed so the signal timings recommended in the *ATX/ATX12V Power Supply Design Guide* are used. Using these recommendations will help drive the industry to an acceptable standard.

### 4.1.4 Voltage Tolerances

Tolerance for the motherboard power rails should comply with the values listed in Table 6.

**Table 6. Voltage Tolerances**

Voltage Rail	Tolerance
+5VDC	± 5 %
-5VDC (if used)	± 10 %
+12VDC	± 5 %
-12VDC	± 10 %
+3.3VDC	± 4 %
+5VSB	± 5 %

## 4.2 Optional Power Connector

In addition to the main power connector, a 2-by-3 optional connector from the power supply can be used in an ATX system for such ancillary functions as fan monitoring, fan control, IEEE-1394 power source, and a remote 3.3 V sense line. Although this connector is **not** required for ATX compliance, it adds benefits that are compelling for a full-featured system:

- The fan monitor features add the ability to monitor and detect fan failures.
- A built-in fan control allows the motherboard to request fan shutdown when the system goes into a sleep or suspend mode.
- Fan speed control is possible to allow for slower fan speeds during low power usage.

Figure 12 shows the pinout of the optional power connector. The PC board connector should be implemented with a Molex 39-30-1060 or equivalent connector. This mates with the power supply connector, Molex 39-01-2060 or equivalent. The exact location of this connector on the motherboard is not specified but should be located near the main connector for convenience.

Proper implementation of FanM, FanC, 3.3 V Sense, 1394V, and 1394R is discussed below. The signals should be implemented according to these specifications if a standard optional connector is used.

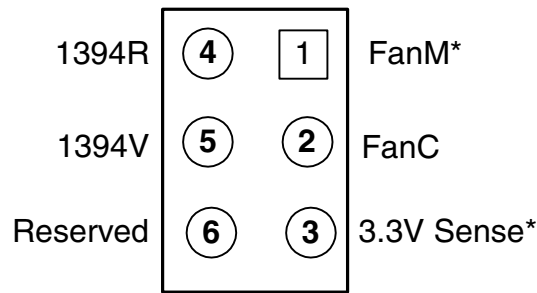

**Figure 12. Optional Power Supply Connector Configuration**

### 4.2.1 FanM Signal

The FanM signal is an open collector, 2 pulse per revolution tachometer signal from the power supply fan. The signal stops cycling during a lock rotor state; the level can be either high or low. This signal allows the system to monitor the power supply for fan speed or failures. Implementation of this signal would allow a system designer to gracefully power down the system in the case of a critical fan failure. The monitoring circuit on the motherboard should use a 1k-Ohm to 10k-Ohm pullup resistor for this signal. The output should be fed into a high impedance gate for the motherboard implementation. Figure 13 shows a simple illustration of the basic circuit requirements. If this signal is not implemented on the motherboard, it should not impact the power supply function.

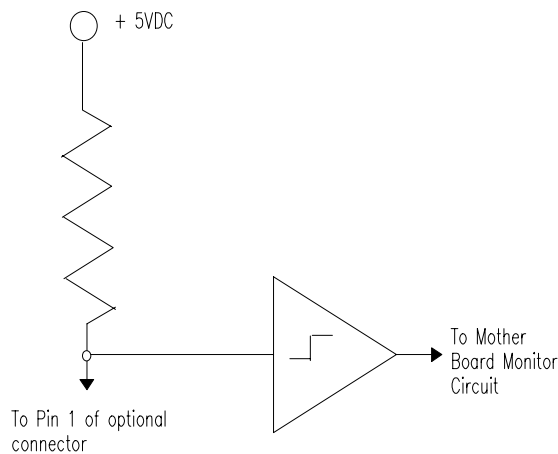

**Figure 13. Simple Implementation of a Fan Monitor Circuit**

### 4.2.2 FanC Signal

The FanC signal is an optional fan speed and shutdown control signal. The fan speed and shutdown are controlled by a variable voltage on this pin. This signal allows the system to request control of the power supply fan from full speed to off. Implementation of this signal would allow a system designer to implement a request-fan-speed control or shut-down during low power states such as sleep or suspend. The control circuit on the motherboard should supply voltage to this pin from +12VDC to 0VDC for the fan control request.

- If a voltage level of +1 volts or less is sensed by the power supply at pin 2 of the optional connector, the fan is requested by the motherboard to shut down.

- If a voltage level of +10.5 volts or higher is being supplied to pin 2, the fan in the power supply is requested to operate at full speed.

The fan control in the power supply may be implemented so that it allows variable speed operation of the fan, depending on the voltage level supplied. If, for example, a +6 V signal is sensed at pin 2, the power supply would operate the fan at a medium speed. If this signal is used for on/off control of the power supply fan, and speed control is not implemented in the fan control circuit of the power supply, the power supply fan should operate at full speed for any voltage level over +1VDC. The power supply should draw no more than 20 mA from pin 2 of the optional power supply connector. A pullup should be used internal to the power supply for this signal so that if the connector is left open, the fan will be requested to operate at full speed.

### 4.2.3 3.3 V Sense Line

A remote 3.3 V sense line can be added to the optional connector to allow for accurate control of the 3.3VDC line directly at motherboard loads. Because of potential voltage drops across the connector and traces leading to the motherboard components, it may be advantageous to implement a 3.3 V sense line that remotely monitors the 3.3VDC power level at the load on the motherboard. The implementation of this signal should be such that if an NC condition is detected on this line, the default 3.3 V sense line on the main connector would be used for sensing the 3.3VDC voltage level.

### 4.2.4 1394 V Pin

This pin on the optional connector allows for implementation of a segregated voltage supply rail for use with unpowered IEEE-1394 solutions. The power derived from this pin should be used to power only 1394 connectors. The output of this power rail is dependent on the 1394 compatibility required. Use of this power rail for motherboard or other power needs may have unpredictable results, because power for 1394 devices is not required to be regulated and may provide voltage levels between 8 and 40 volts. See the applicable IEEE-1394 specification for details on the specific power requirements for this voltage rail. If this power rail is implemented, it should operate such that the main PS\_ON# signal must be asserted low for power to be delivered at this connector.

### 4.2.5 1394R Pin

The 1394R pin provides an isolated ground path for unpowered 1394 implementations. This ground should be used only for 1394 connections and should be fully isolated from other ground planes in the system.

## 5. Other ATX Chassis Considerations

---

An ATX-compliant chassis should be designed so that it will allow for all ATX 2.1-compliant motherboards to be integrated. Although not explicitly stated throughout the text, a chassis should implement all features necessary to properly support a complete ATX solution. Many of the chassis features are embedded in the text, but others that are related only to the chassis that will be pointed out in the following section.

### 5.1 Venting

Adequate venting should be provided in the system to allow for unimpeded and well-directed airflow to cool key components such as the processor. One recommendation that is implicit in the ATX specification is the placement of the power supply. The power supply should be placed in close proximity to the processor if the power supply is expected to cool the processor properly (but be sure to observe the component height keepouts over the PC board). Chassis venting should be placed strategically to allow for proper cooling of other components such as peripherals and add-in cards. A system fan should be considered to allow for proper cooling of all system components.

### 5.2 Power Supply Mounting

If the power supply is mounted so that it must be removed to allow for integration of Field Replaceable Units (FRU), consideration should be made for easy removal of the power supply. Some of the typical FRU components that should be considered are the processor, memory, add-in cards, and peripherals. Use of a common fastener such as a standard screw that is easily accessible should be considered for mounting power supplies that interfere with easy component integration.

## 6. Additional Information

---

For additional information beyond the requirements of this *ATX Specification* (including thermal solutions, power supply design recommendations, I/O shield examples, and vendor information), refer to:

<http://www.formfactors.org>

or contact your Intel representative.