

FD2004 — Adaptive Digital DC-DC Controller with Current Sharing

1. Overview

1.1. Features

Power Conversion

- Efficient Synchronous Buck Controller
- Adaptive Performance Optimization Algorithms
- 4.5V to 14V Input Range
- 0.54V to 4V Output Range (with Margin)
- $\pm 1\%$ V_{OUT} Setpoint Accuracy
- Fast Load Transient Response
- Current Sharing and Phase Interleaving
- Digitally Adjustable Current Sense Range
- *Snapshot™* Parametric Capture Mechanism
- RoHS-Compliant (5 x 5mm) QFN Package

Power Management

- Digital Soft-Start/Stop
- Precision Delay and Ramp-up
- Power Good / Enable
- Voltage Tracking, Sequencing, and Margining
- Voltage / Current / Temperature Monitoring
- SMBus Communication (PMBus™ Compliant)
- Output Voltage and Current Protection
- Internal Non-volatile Memory (NVM)

1.2. Applications

- Servers / Storage Equipment
- Telecom / Datacom Equipment
- Power Supplies (Memory, DSP, ASIC, FPGA)

1.3. Description

The FD2004 is a digital DC-DC controller designed to work with the FD1505 MOSFET driver IC. Current sharing allows multiple devices to be connected in parallel to source loads with very high current demands. Adaptive performance optimization algorithms improve power conversion efficiency across the load range. The Digital-DC™ technology enables a blend of power conversion performance and power management features.

The FD2004 is designed to be a flexible building block for DC power and can be easily adapted to designs ranging from a single-phase power supply operating from a 4.5V input to a multi-phase supply operating from a 12V input. The FD2004 eliminates the need for complicated power supply managers as well as numerous external discrete components.

Operating features can be configured by pin-strap / resistor selection or through the SMBus serial interface. FD2004 uses the PMBus™ protocol for communication with a host controller and the inter-device DDC bus for communication with other Digital-DC devices.

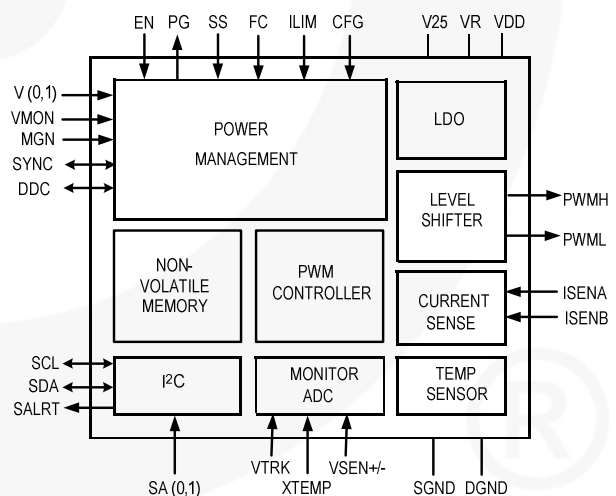

Figure 1. Block Diagram

PMBus™ is a trademark of the PMB Implementers Forum and System Management Interface Forum (SMIF).



TRADEMARKS

The following includes registered and unregistered trademarks and service marks, owned by Fairchild Semiconductor and/or its global subsidiaries, and is not intended to be an exhaustive list of all such trademarks.

- | | | | |
|--------------------------|------------------------|---------------------------------------|----------------------|
| Build it Now™ | F-PFET™ | PowerTrench® | The Power Franchise® |
| CorePLUS™ | FRFET® | Programmable Active Droop™ | |
| CorePOWER™ | Global Power Resource™ | QFET® | TinyBoost™ |
| CROSSVOL™ | Green FPST™ | QST™ | TinyBuck™ |
| CTL™ | Green FPST™ e-Series™ | Quiet Series™ | TinyLogic® |
| Current Transfer Logic™ | GTO™ | RapidConfigure™ | TINYOPTO™ |
| EcoSPARK® | IntelliMAX™ | | TinyPower™ |
| EfficientMax™ | ISOPLANAR™ | Saving our world, 1mW/W/kW at a time™ | TinyPWM™ |
| EZSWITCH™* | MegaBuck™ | SmartMax™ | TinyWire™ |
| | MICROCOUPLER™ | SMART START™ | µSerDes™ |
| | MicroFET™ | SPM® | |
| Fairchild® | MicroPak™ | STEALTH™ | UHC® |
| Fairchild Semiconductor® | MillerDrive™ | SuperFET™ | Ultra FRFET™ |
| FACT Quiet Series™ | MotionMax™ | SuperSOT™.3 | UnifET™ |
| FACT® | Motion-SPM™ | SuperSOT™.6 | Vcx™ |
| FAST® | OPTOLOGIC® | SuperSOT™.8 | VisualMax™ |
| FastvCore™ | OPTOPLANAR® | SupreMOS™ | |
| FlashWriter®* | | SyncFET™ | |
| FPST™ | PDP µPM™ | | |
| | Power-SPM™ | | |

* EZSWITCH™ and FlashWriter® are trademarks of System General Corporation, used under license by Fairchild Semiconductor.

DISCLAIMER

FAIRCHILD SEMICONDUCTOR RESERVES THE RIGHT TO MAKE CHANGES WITHOUT FURTHER NOTICE TO ANY PRODUCTS HEREIN TO IMPROVE RELIABILITY, FUNCTION, OR DESIGN. FAIRCHILD DOES NOT ASSUME ANY LIABILITY ARISING OUT OF THE APPLICATION OR USE OF ANY PRODUCT OR CIRCUIT DESCRIBED HEREIN; NEITHER DOES IT CONVEY ANY LICENSE UNDER ITS PATENT RIGHTS, NOR THE RIGHTS OF OTHERS. THESE SPECIFICATIONS DO NOT EXPAND THE TERMS OF FAIRCHILD'S WORLDWIDE TERMS AND CONDITIONS, SPECIFICALLY THE WARRANTY THEREIN, WHICH COVERS THESE PRODUCTS.

LIFE SUPPORT POLICY

FAIRCHILD'S PRODUCTS ARE NOT AUTHORIZED FOR USE AS CRITICAL COMPONENTS IN LIFE SUPPORT DEVICES OR SYSTEMS WITHOUT THE EXPRESS WRITTEN APPROVAL OF FAIRCHILD SEMICONDUCTOR CORPORATION.

As used herein:

- Life support devices or systems are devices or systems which, (a) are intended for surgical implant into the body or (b) support or sustain life, and (c) whose failure to perform when properly used in accordance with instructions for use provided in the labeling, can be reasonably expected to result in a significant injury of the user.
- A critical component in any component of a life support, device, or system whose failure to perform can be reasonably expected to cause the failure of the life support device or system, or to affect its safety or effectiveness.

ANTI-COUNTERFEITING POLICY

Fairchild Semiconductor Corporation's Anti-Counterfeiting Policy. Fairchild's Anti-Counterfeiting Policy is also stated on our external website, www.fairchildsemi.com, under Sales Support.

Counterfeiting of semiconductor parts is a growing problem in the industry. All manufacturers of semiconductor products are experiencing counterfeiting of their parts. Customers who inadvertently purchase counterfeit parts experience many problems such as loss of brand reputation, substandard performance, failed applications, and increased cost of production and manufacturing delays. Fairchild is taking strong measures to protect ourselves and our customers from the proliferation of counterfeit parts. Fairchild strongly encourages customers to purchase Fairchild parts either directly from Fairchild or from Authorized Fairchild Distributors who are listed by country on our web page cited above. Products customers buy either from Fairchild directly or from Authorized Fairchild Distributors are genuine parts, have full traceability, meet Fairchild's quality standards for handling and storage and provide access to Fairchild's full range of up-to-date technical and product information. Fairchild and our Authorized Distributors will stand behind all warranties and will appropriately address any warranty issues that may arise. Fairchild will not provide any warranty coverage or other assistance for parts bought from Unauthorized Sources. Fairchild is committed to combat this global problem and encourage our customers to do their part in stopping this practice by buying direct or from authorized distributors.

PRODUCT STATUS DEFINITIONS

Definition of Terms

| Datasheet Identification | Product Status | Definition |
|--------------------------|-----------------------|---|
| Advance Information | Formative / In Design | Datasheet contains the design specifications for product development. Specifications may change in any manner without notice. |
| Preliminary | First Production | Datasheet contains preliminary data; supplementary data will be published at a later date. Fairchild Semiconductor reserves the right to make changes at any time without notice to improve design. |
| No Identification Needed | Full Production | Datasheet contains final specifications. Fairchild Semiconductor reserves the right to make changes at any time without notice to improve the design. |
| Obsolete | Not In Production | Datasheet contains specifications on a product that is discontinued by Fairchild Semiconductor. The datasheet is for reference information only. |

Rev. I36

Digital-DC™, and Snapshot™ are trademarks of Zilker Labs, Inc., used under license by Fairchild Semiconductor. All other products or brand names mentioned herein are trademarks of their respective holders.

PMBus™ is a trademark of the PMB Implementers Forum and System Management Interface Forum (SMIF).