

## Off-line high voltage converters

### Features

- 800 V avalanche rugged power section
- PWM operation with frequency jittering for low EMI
- Operating frequency:
  - 60 kHz for L type
  - 115 kHz for H type
- Standby power < 50 mW at 265 Vac
- Limiting current with adjustable set point
- Adjustable and accurate over voltage protection
- On-board soft-start
- Safe auto-restart after a fault condition
- Hysteretic thermal shutdown

### Application

- Adapters for PDA, camcorders, shavers, cellular phones, videogames
- Auxiliary power supply for LCD/PDP TV, monitors, audio systems, computer, industrial systems
- SMPS for set-top boxes, DVD players and recorders, white goods

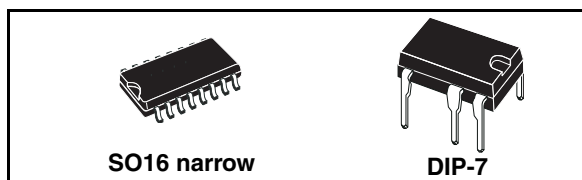

### Description

The device is an off-line converter with an 800 V rugged power section, a PWM control, two levels of over current protection, over voltage and overload protections, hysteretic thermal protection, soft-start and safe auto-restart after any fault condition removal. Burst mode operation and device very low consumption helps to meet the standby energy saving regulations.

Advance frequency jittering reduces EMI filter cost. Brown-out function protects the switch mode power supply when the rectified input voltage level is below the normal minimum level specified for the system. The high voltage start-up circuit is embedded in the device.

**Figure 1. Typical topology**

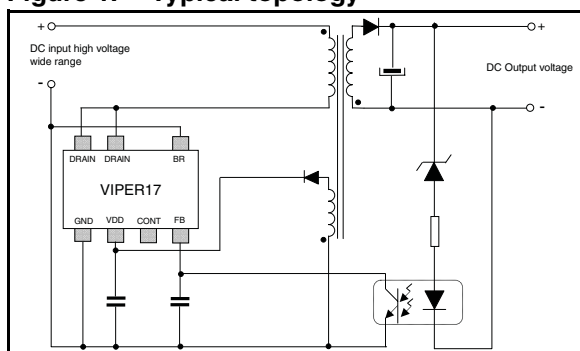

**Table 1. Device summary**

Order codes	Package	Packaging
VIPER17LN	DIP-7	Tube
VIPER17HN		
VIPER17HD	SO16 narrow	Tube
VIPER17HDTR		Tape and reel
VIPER17LD		Tube
VIPER17LDTR		Tape and reel

# Contents

- 1      Block diagram ..... 4**
- 2      Typical power ..... 4**
- 3      Pin settings ..... 5**
  - 3.1    Connection diagram ..... 5
  - 3.2    Pin description ..... 5
- 4      Electrical data ..... 6**
  - 4.1    Maximum ratings ..... 6
  - 4.2    Thermal data ..... 6
  - 4.3    Electrical characteristics ..... 7
- 5      Typical electrical characteristics ..... 11**
- 6      Typical circuit ..... 14**
- 7      Operation descriptions ..... 15**
  - 7.1    Power section and gate driver ..... 15
  - 7.2    High voltage startup generator ..... 15
  - 7.3    Power-up and soft-start up ..... 16
  - 7.4    Power down operation ..... 18
  - 7.5    Auto restart operation ..... 18
  - 7.6    Oscillator ..... 18
  - 7.7    Current mode conversion with adjustable current limit set point ..... 19
  - 7.8    Over voltage protection (OVP) ..... 19
  - 7.9    About CONT pin ..... 21
  - 7.10    Feed-back and over load protection (OLP) ..... 21
  - 7.11    Burst-mode operation at no load or very light load ..... 24
  - 7.12    Brown-out protection ..... 25
  - 7.13    2nd level over current protection and hiccup mode ..... 27

---

<b>8</b>	<b>Package mechanical data .....</b>	<b>28</b>
<b>9</b>	<b>Revision history .....</b>	<b>32</b>

# 1 Block diagram

Figure 2. Block diagram

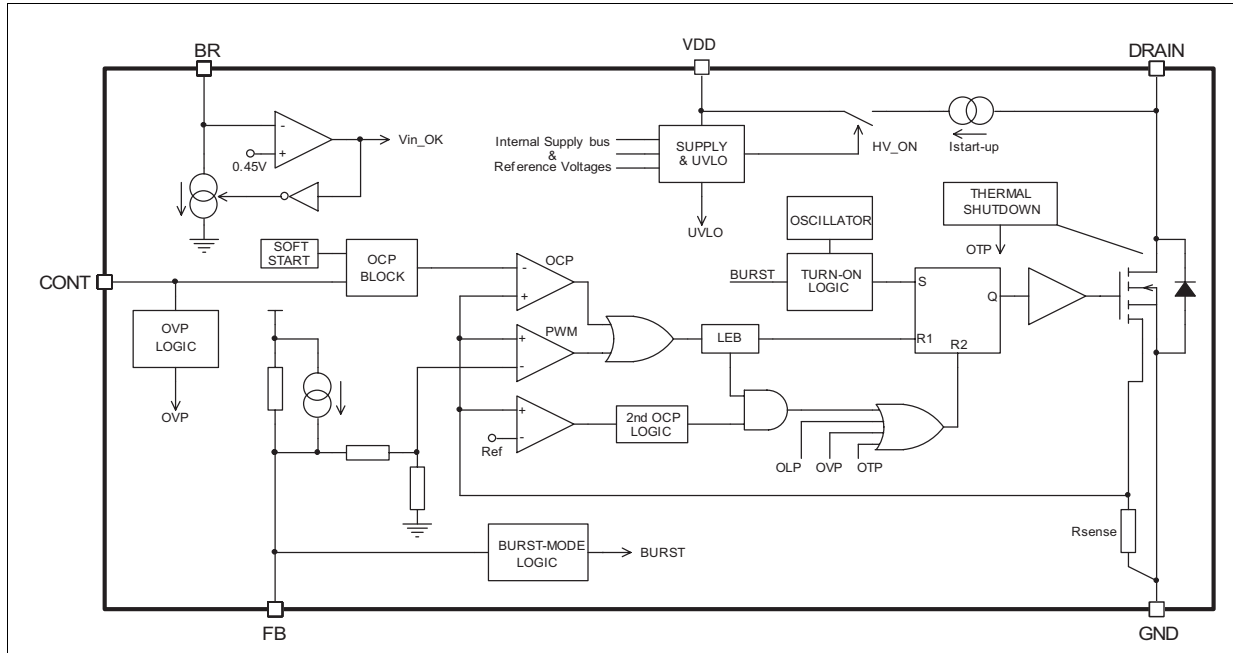

# 2 Typical power

Table 2. Typical power

Part number	230 V <sub>AC</sub>		85-265 V <sub>AC</sub>	
	Adapter <sup>(1)</sup>	Open frame <sup>(2)</sup>	Adapter <sup>(1)</sup>	Open frame <sup>(2)</sup>
VIPER17	9 W	12 W	5 W	7 W

1. Typical continuous power in non ventilated enclosed adapter measured at 50 °C ambient.
2. Maximum practical continuous power in an open frame design at 50 °C ambient, with adequate heat sinking.

## 3 Pin settings

### 3.1 Connection diagram

Figure 3. Connection diagram (top view)

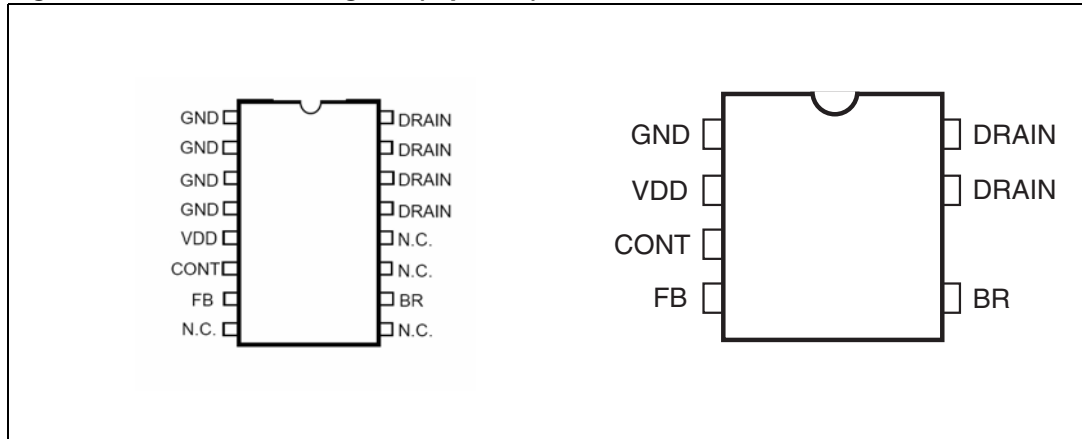

### 3.2 Pin description

Table 3. Pin description

Pin N.		Name	Function
DIP-7	SO16		
1	1...4	GND	This pin represents the device ground and the source of the power section.
2	5	VDD	Supply voltage of the control section. This pin also provides the charging current of the external capacitor during start-up time.
3	6	CONT	Control pin. The following functions can be selected: 1. current limit set point adjustment. The internal set default value of the cycle-by-cycle current limit can be reduced by connecting to ground an external resistor. 2. output voltage monitoring. A voltage exceeding 3 V shuts the IC down reducing the device consumption. This function is strobed and digitally filtered for high noise immunity.
4	7	FB	Control input for duty cycle control. Internal current generator provides bias current for loop regulation. A voltage below 0.5 V activates the burst-mode operation. A level close to 3.3 V means that we are approaching the cycle-by-cycle over-current set point.
5	10	BR	Brownout protection input with hysteresis. A voltage below 0.45 V shuts down (not latch) the device and lowers the power consumption. Device operation restarts as the voltage exceeds 0.45 V plus hysteresis voltage. It can be connected to ground when not used.
7,8	13...16	DRAIN	High voltage drain pin. The built-in high voltage switched start-up bias current is drawn from this pin too.

## 4 Electrical data

### 4.1 Maximum ratings

**Table 4. Absolute maximum ratings**

Symbol	Pin	Parameter	Value	Unit
$V_{DRAIN}$	7, 8	Drain-to-source (ground) voltage	800	V
$E_{AV}$	7, 8	Repetitive avalanche energy (limited by $T_J = 150\text{ °C}$ )	2	mJ
$I_{AR}$	7, 8	Repetitive avalanche current (limited by $T_J = 150\text{ °C}$ )	1	A
$I_{DRAIN}$	7, 8	Pulse drain current	2.5	A
$V_{CONT}$	3	Control input pin voltage (with $I_{CONT} = 1\text{ mA}$ )	Self limited	V
$V_{FB}$	4	Feed-back voltage	-0.3 to 5.5	V
$V_{BR}$	5	Brown-out input pin voltage	2	V
$V_{DD}$	2	Supply voltage ( $I_{DD} = 25\text{ mA}$ )	Self limited	V
$P_{TOT}$		Power dissipation at $T_A < 50\text{ °C}$	1	W
$T_J$		Operating junction temperature range	Internally limited	°C
$T_{STG}$		Storage temperature	-55 to 150	°C

### 4.2 Thermal data

**Table 5. Thermal data**

Symbol	Parameter	Max value SO16N	Max value DIP7	Unit
$R_{thJP}$	Thermal resistance junction pin	35	40	°C/W
$R_{thJA}$	Thermal resistance junction ambient <sup>(1)</sup>	80	90	°C/W

1. When mounted on a standard single side FR4 board with  $100\text{ }\mu\text{m}^2$  (0.155 sq in) of Cu (35  $\mu\text{m}$  thick)

### 4.3 Electrical characteristics

( $T_J = -25$  to  $125$  °C,  $V_{DD} = 14$  V; unless otherwise specified)

**Table 6. Power section**

Symbol	Parameter	Test condition	Min	Typ	Max	Unit
$V_{BVDS}$	Break-down voltage	$I_{DRAIN} = 1$ mA, $V_{FB} = GND$ $T_J = 25$ °C	800			V
$I_{OFF}$	OFF state drain current	$V_{DRAIN} = \text{max rating}$ , $V_{FB} = GND$			60	μA
$R_{DS(on)}$	Drain-source on state resistance	$I_{DRAIN} = 0.2$ A, $V_{FB} = 3$ V, $V_{BR} = GND$ , $T_J = 25$ °C		20	24	Ω
		$I_{DRAIN} = 0.2$ A, $V_{FB} = 3$ V, $V_{BR} = GND$ , $T_J = 125$ °C		40	48	Ω
$C_{OSS}$	Effective (energy related) output capacitance	$V_{DRAIN} = 0$ to $640$ V		10		pF

**Table 7. Supply section**

Symbol	Parameter	Test condition	Min	Typ	Max	Unit
<b>Voltage</b>						
$V_{DRAIN\_START}$	Drain-source start voltage		60	80	100	V
$I_{DD\_CH}$	Start up charging current	$V_{DRAIN} = 120$ V, $V_{BR} = GND$ , $V_{FB} = GND$ , $V_{DD} = 4$ V	-2	-3	-4	mA
		$V_{DRAIN} = 120$ V , $V_{BR} = GND$ , $V_{FB} = GND$ , $V_{DD} = 4$ V after fault.	-0.4	-0.6	-0.8	mA
$V_{DD}$	Operating voltage range	After turn-on	8.5		23.5	V
$V_{DDclamp}$	$V_{DD}$ clamp voltage	$I_{DD} = 20$ mA	23.5			V
$V_{DDon}$	$V_{DD}$ start up threshold		13	14	15	V
$V_{DDoff}$	$V_{DD}$ under voltage shutdown threshold	$V_{DRAIN} = 120$ V, $V_{BR} = GND$ , $V_{FB} = GND$	7.5	8	8.5	V
$V_{DD(RESTART)}$	$V_{DD}$ restart voltage threshold	$V_{DRAIN} = 120$ V, $V_{BR} = GND$ , $V_{FB} = GND$	4	4.5	5	V
<b>Current</b>						
$I_{DD0}$	Operating supply current, not switching	$V_{FB} = GND$ , $F_{SW} = 0$ kHz, $V_{BR} = GND$ , $V_{DD} = 10$ V			0.9	mA
$I_{DD1}$	Operating supply current, switching	$V_{DRAIN} = 120$ V, $F_{SW} = 60$ kHz			1.8	mA
		$V_{DRAIN} = 120$ V, $F_{SW} = 115$ kHz			2	mA
$I_{DD\_FAULT}$	Operating supply current, with protection tripping				400	μA
$I_{DD\_OFF}$	Operating supply current with $V_{DD} < V_{DD\_OFF}$	$V_{DD} = 7$ V			270	μA

**Table 8. Controller section**  
( $T_J = -25$  to  $125$  °C,  $V_{DD} = 14$  V; unless otherwise specified)

Symbol	Parameter	Test condition	Min	Typ	Max	Unit
<b>Feed-back pin</b>						
$V_{FB\_olp}$	Over load shut down threshold		4.7	4.8	5.2	V
$V_{FB\_lin}$	Linear dynamics upper limit		3.2	3.3	3.4	V
$V_{FB\_bm}$	Burst mode threshold	Voltage falling	0.4	0.5	0.6	V
$V_{FB\_bm\_hys}$	Burst mode hysteresis	Voltage rising		50		mV
$I_{FB}$	Feed-back sourced current	$V_{FB} = 0.3$ V	-150	-200	-280	uA
		$3.3$ V < $V_{FB}$ < $4.8$ V		-3		uA
$R_{FB(DYN)}$	Dynamic resistance	$V_{FB} < 3.3$ V	14		19	k $\Omega$
$H_{FB}$	$\Delta V_{FB} / \Delta I_D$		4		9	V/A
<b>CONT pin</b>						
$V_{CONT\_I}$	Low level clamp voltage	$I_{CONT} = -100$ $\mu$ A		0.5		V
<b>Current limitation</b>						
$I_{Dim}$	Max drain current limitation	$V_{FB} = 4$ V, $I_{CONT} = -10$ $\mu$ A $T_J = 25$ °C	0.38	0.4	0.42	A
$t_{SS}$	Soft-start time			8.5		ms
$T_{ON\_MIN}$	Minimum turn ON time		220	400	480	ns
$t_d$	Propagation delay			100		ns
$t_{LEB}$	Leading edge blanking			300		ns
$I_{D\_BM}$	Peak drain current during burst mode	$V_{FB} = 0.6$ V		90		mA
<b>Oscillator section</b>						
$F_{OSC}$	VIPER17L	$V_{DD}$ = operating voltage range, $V_{FB} = 1$ V	54	60	66	kHz
	VIPER17H		103	115	127	kHz
FD	Modulation depth	VIPER17L		$\pm 4$		kHz
		VIPER17H		$\pm 8$		kHz
FM	Modulation frequency			250		Hz
$D_{MAX}$	Maximum duty cycle		70		80	%



**Table 8. Controller section (continued)**  
 ( $T_J = -25$  to  $125$  °C,  $V_{DD} = 14$  V; unless otherwise specified)

Symbol	Parameter	Test condition	Min	Typ	Max	Unit
<b>Over current protection ( 2<sup>nd</sup> OCP )</b>						
$I_{D\text{MAX}}$	Second over current threshold			0.6		A
<b>Over voltage protection</b>						
$V_{\text{OVP}}$	Over voltage protection threshold		2.7	3	3.3	V
$T_{\text{STROBE}}$	Over voltage protection strobe time			2.2		$\mu\text{s}$
<b>Brown out protection</b>						
$V_{\text{BRth}}$	Brown out threshold	Voltage falling	0.41	0.45	0.49	V
$V_{\text{BR Hyst}}$	Voltage hysteresis above $V_{\text{BRth}}$			50		mV
$I_{\text{BR Hyst}}$	Current hysteresis		7		10	$\mu\text{A}$
$V_{\text{BR}}$	Operating range		0.15		2	V
$V_{\text{DIS}}$	Brown out disable voltage		50		150	mV
<b>Thermal shutdown</b>						
$T_{\text{SD}}$	Thermal shutdown temperature		150	170		°C
$T_{\text{HYST}}$	Thermal shutdown hysteresis			30		°C

Figure 4. Minimum turn-on time test circuit

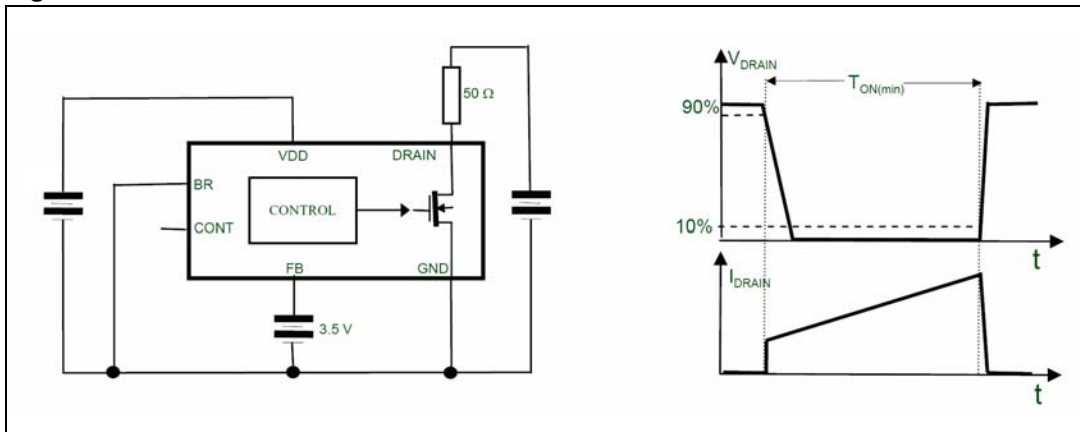

Figure 5. Brown out threshold test circuits

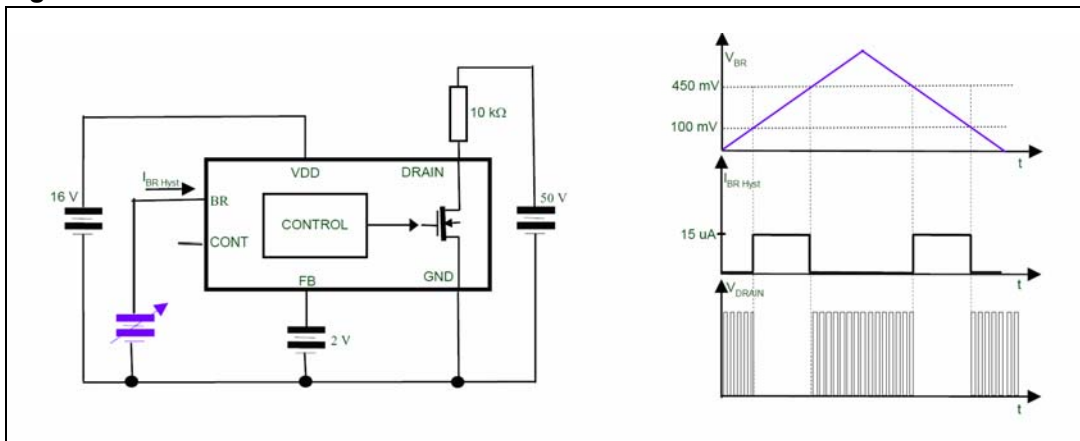
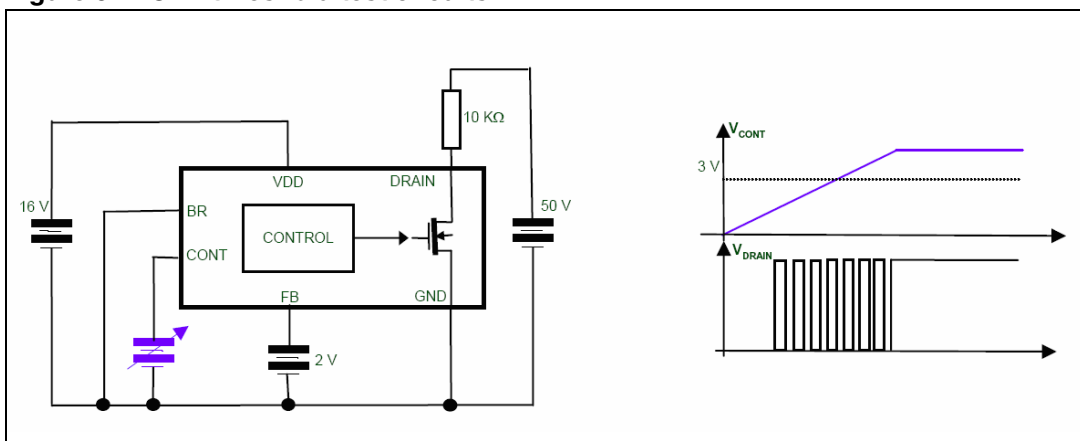

Figure 6. OVP threshold test circuits



# 5 Typical electrical characteristics

Figure 7. Current limit vs  $T_J$

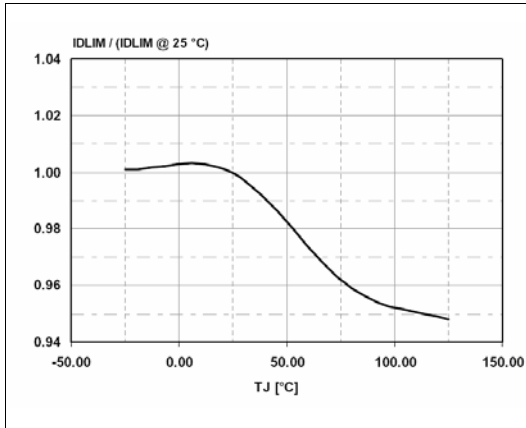

Figure 8. Switching frequency vs  $T_J$

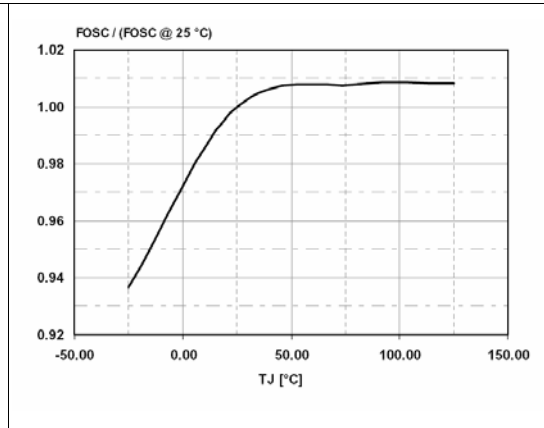

Figure 9. Drain start voltage vs  $T_J$

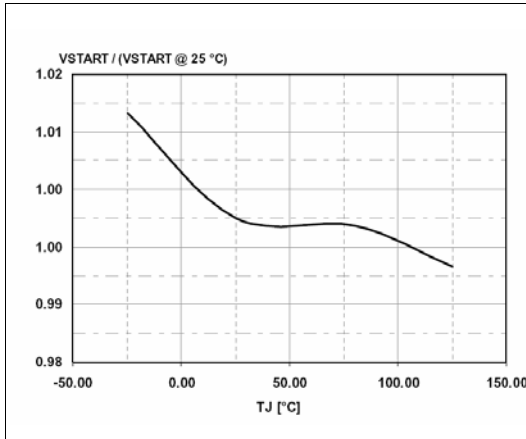

Figure 10. HFB vs  $T_J$

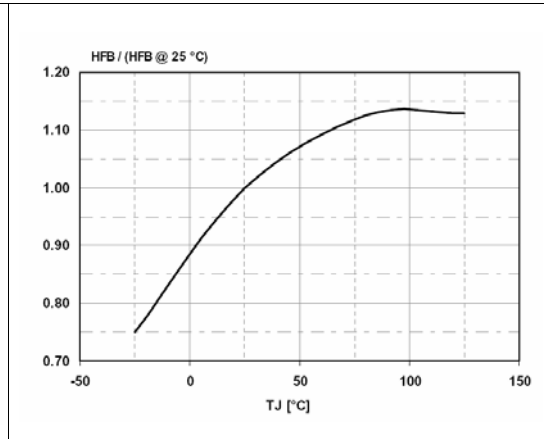

Figure 11. Brown out threshold vs  $T_J$

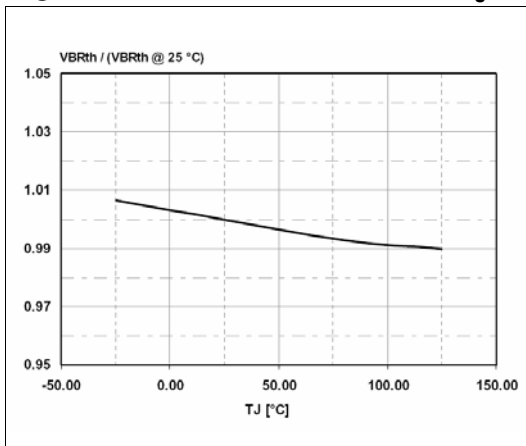

Figure 12. Brown out hysteresis vs  $T_J$

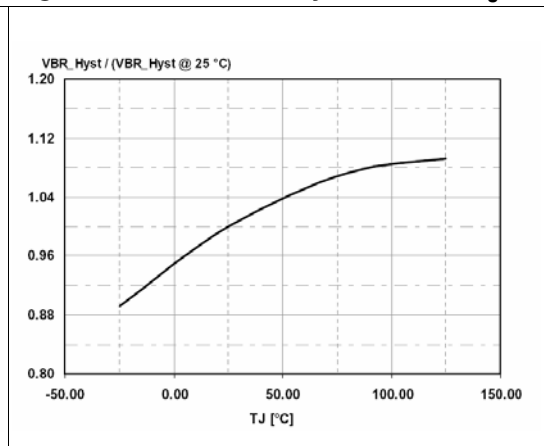

Figure 13. Brown out hysteresis current vs  $T_J$

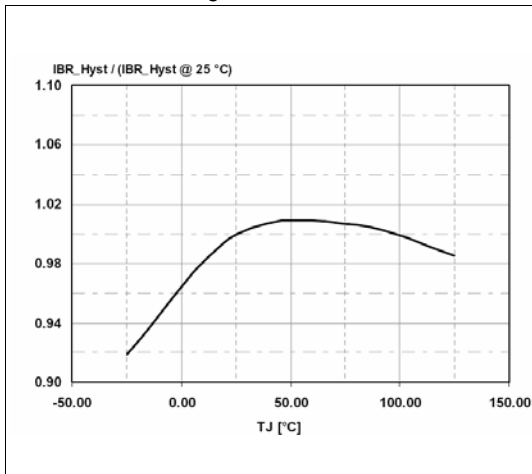

Figure 14. Operating supply current (no switching) vs  $T_J$

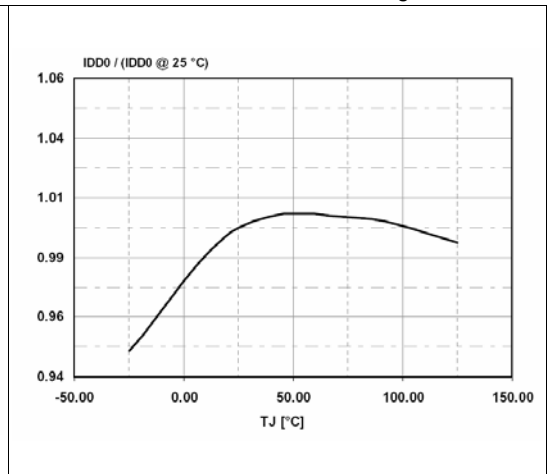

Figure 15. Operating supply current (switching) vs  $T_J$

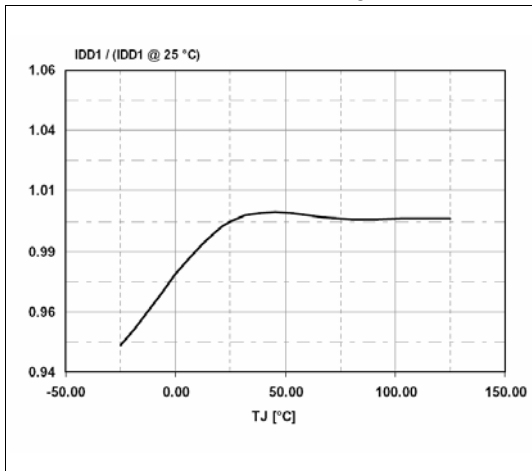

Figure 16. current limit vs  $R_{LIM}$

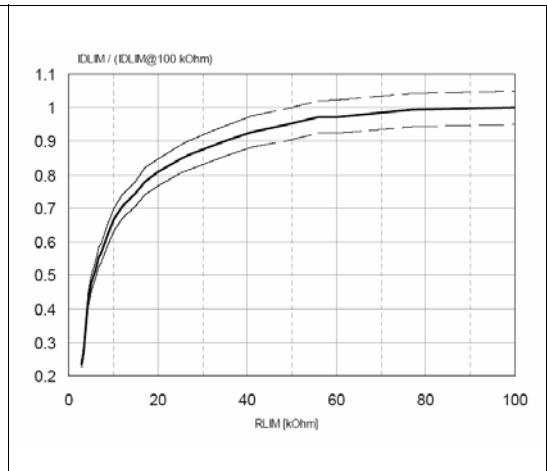

Figure 17. Power MOSFET on-resistance vs  $T_J$

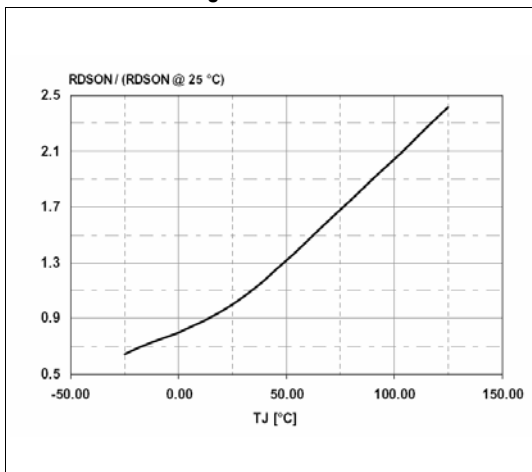

Figure 18. Power MOSFET break down voltage vs  $T_J$

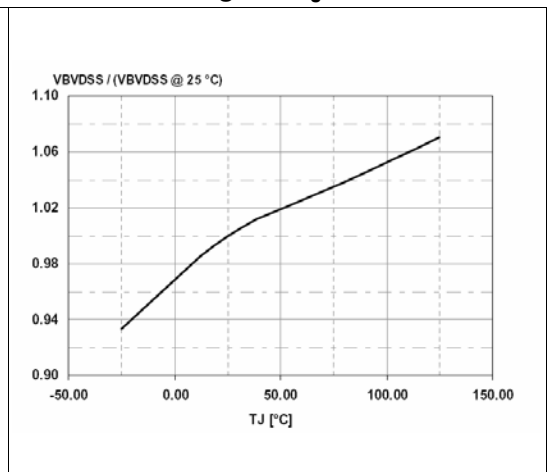
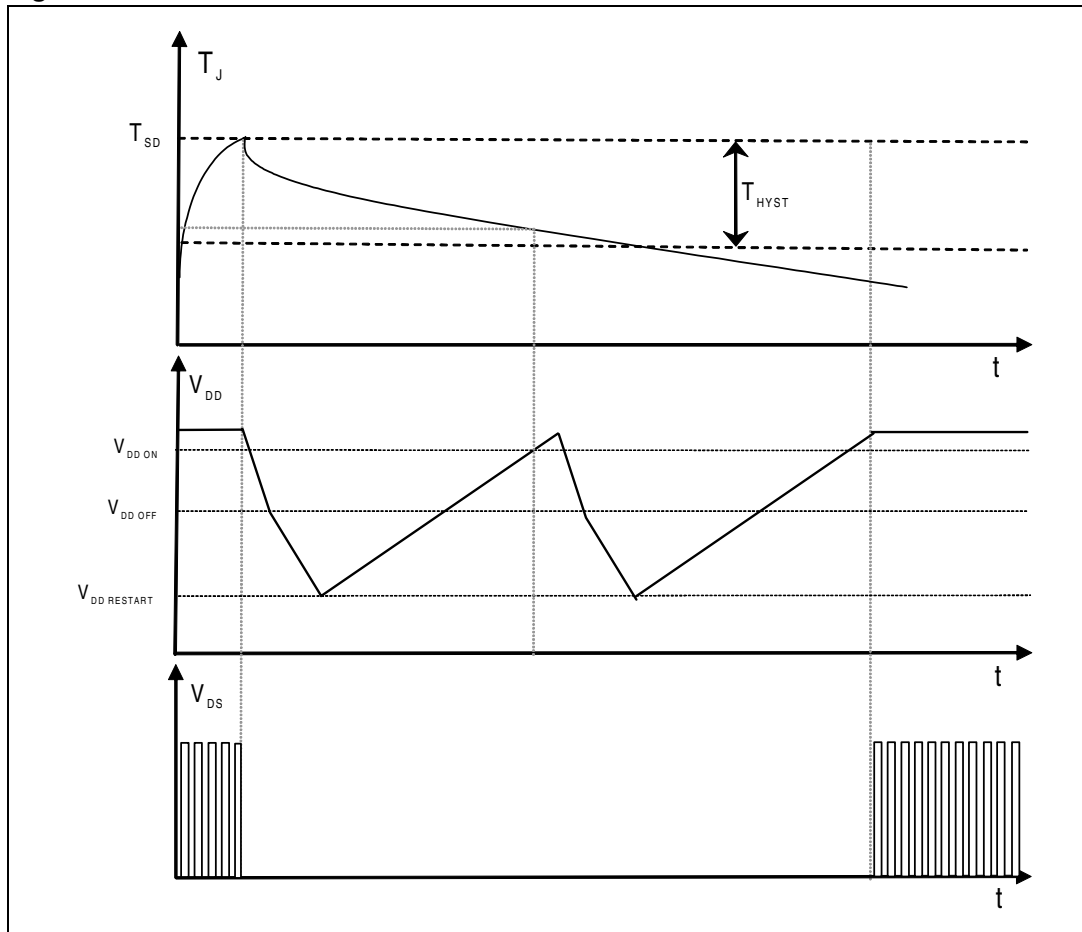

Figure 19. Thermal shutdown



# 6 Typical circuit

Figure 20. Flyback application (basic)

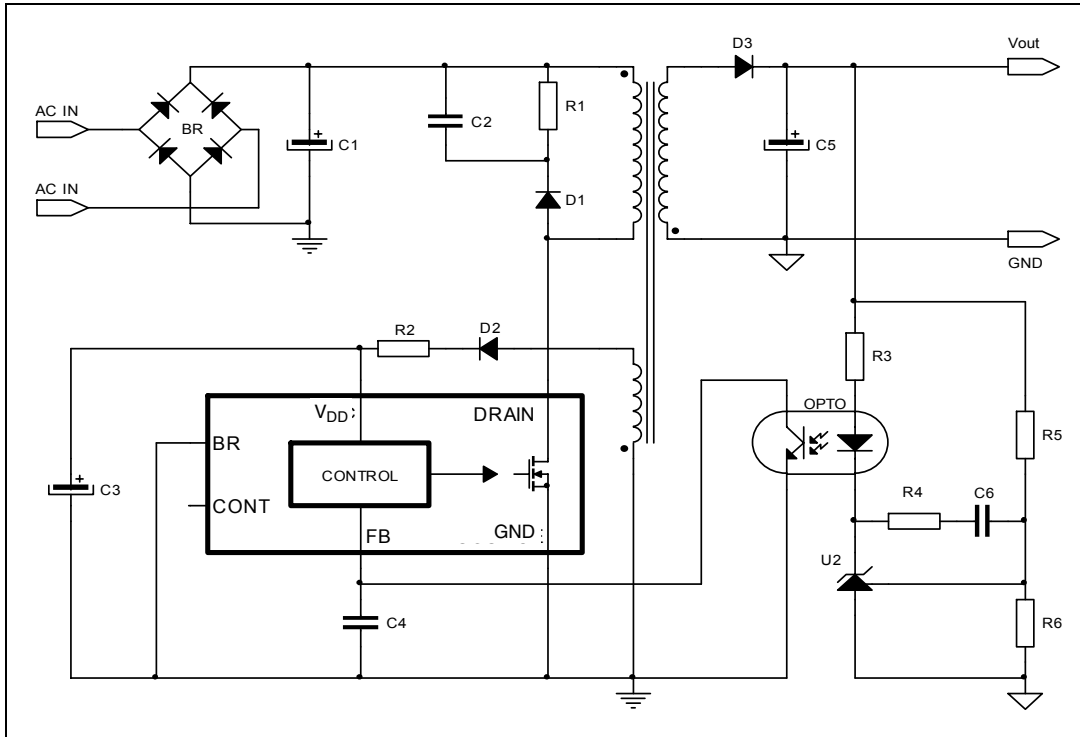
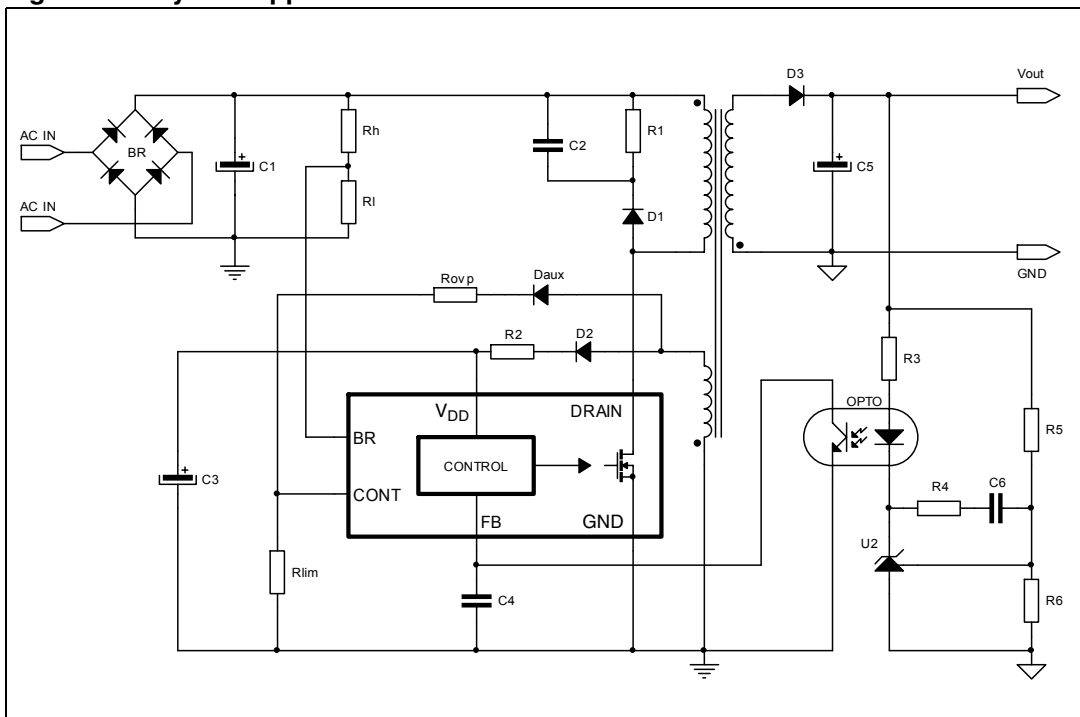

Figure 21. Flyback application



## 7 Operation descriptions

VIPER17 is a high-performance low-voltage PWM controller chip with an 800 V, avalanche rugged Power section.

The controller includes: the oscillator with jittering feature, the start up circuits with soft-start feature, the PWM logic, the current limit circuit with adjustable set point, the second over current circuit, the burst mode management, the brown-out circuit, the UVLO circuit, the auto-restart circuit and the thermal protection circuit.

The current limit set-point is set by the CONT pin. The burst mode operation guaranties high performance in the stand-by mode and helps in the energy saving norm accomplishment.

All the fault protections are built in auto restart mode with very low repetition rate to prevent IC's over heating.

### 7.1 Power section and gate driver

The power section is implemented with an avalanche ruggedness N-channel MOSFET, which guarantees safe operation within the specified energy rating as well as high dv/dt capability. The Power section has a  $BV_{DSS}$  of 800 V min. and a typical  $R_{DS(on)}$  of 20  $\Omega$  at 25 °C.

The integrated SenseFET structure allows a virtually loss-less current sensing.

The gate driver is designed to supply a controlled gate current during both turn-on and turn-off in order to minimize common mode EMI. Under UVLO conditions an internal pull-down circuit holds the gate low in order to ensure that the Power section cannot be turned on accidentally.

### 7.2 High voltage startup generator

The HV current generator is supplied through the DRAIN pin and it is enabled only if the input bulk capacitor voltage is higher than  $V_{DRAIN\_START}$  threshold, 80  $V_{DC}$  typically. When the HV current generator is ON, the  $I_{DD\_ch}$  current (3 mA typical value) is delivered to the capacitor on the  $V_{DD}$  pin. In case of Auto Restart mode after a fault event, the  $I_{DD\_ch}$  current is reduced to 0.6 mA, typ. in order to have a slow duty cycle during the restart phase.

### 7.3 Power-up and soft-start up

If the input voltage rises up till the device start level ( $V_{DRAIN\_START}$ ), the  $V_{DD}$  voltage begins to grow due to the  $I_{DD\_ch}$  current (see [Table 7 on page 7](#)) coming from the internal high voltage start up circuit. If the  $V_{DD}$  voltage reaches  $V_{DDon}$  threshold (~14 V) the power MOSFET starts switching and the HV current generator is turned OFF. See [Figure 23 on page 17](#).

The IC is powered by the energy stored in the capacitor on the VDD pin,  $C_{VDD}$ , until when the self-supply circuit (typically an auxiliary winding of the transformer and a steering diode) develops a voltage high enough to sustain the operation.

$C_{VDD}$  capacitor must be sized enough to avoid fast discharge and keep the needed voltage value higher than  $V_{DDoff}$  threshold. In fact, a too low capacitance value could terminate the switching operation before the controller receives any energy from the auxiliary winding.

The following formula can be used for the  $V_{DD}$  capacitor calculation:

**Equation 1**

$$C_{VDD} = \frac{I_{DDch} \times t_{SSaux}}{V_{DDon} - V_{DDoff}}$$

The  $t_{SSaux}$  is the time needed for the steady state of the auxiliary voltage. This time is estimated by applicator according to the output stage configurations (transformer, output capacitances, etc).

During the converter start up time, the drain current limitation is progressively increased to the maximum value. In this way the stress on the secondary diode is considerably reduced. It also helps to prevent transformer saturation. The soft-start time lasts 8.5 ms and the feature is implemented for every attempt of start up converter or after a fault.

**Figure 22. Start up  $I_{DD}$  current**

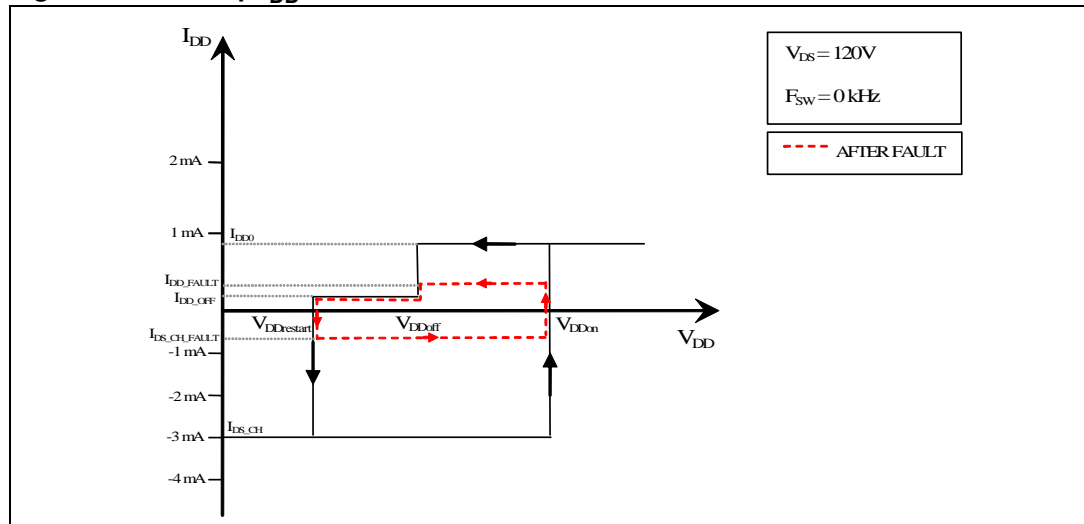



Figure 23. Timing diagram: normal power-up and power-down sequences

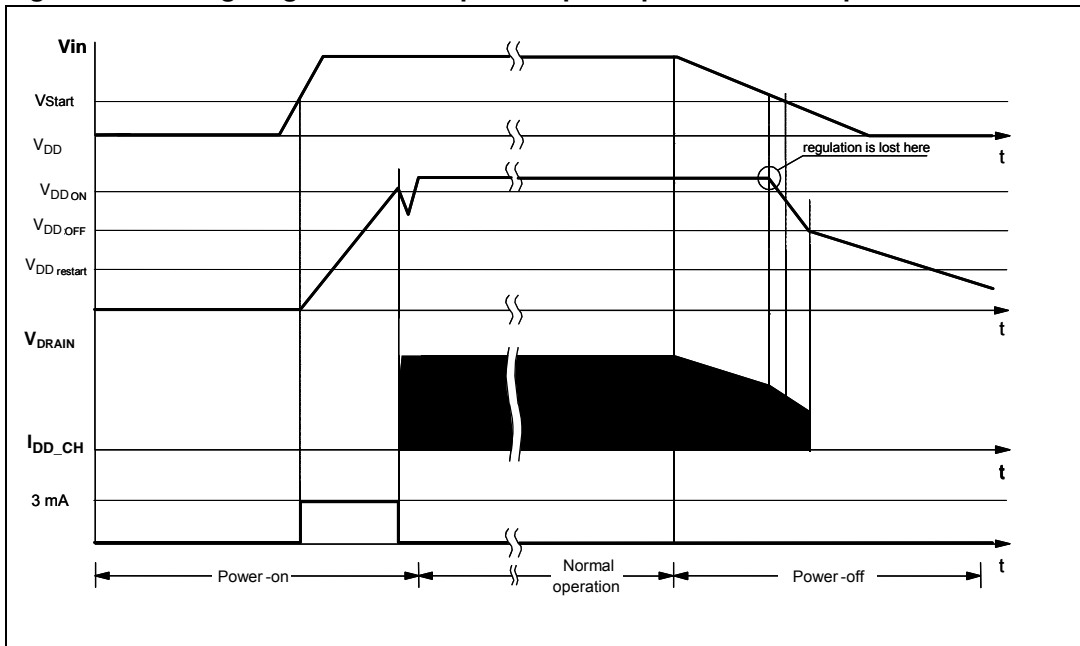
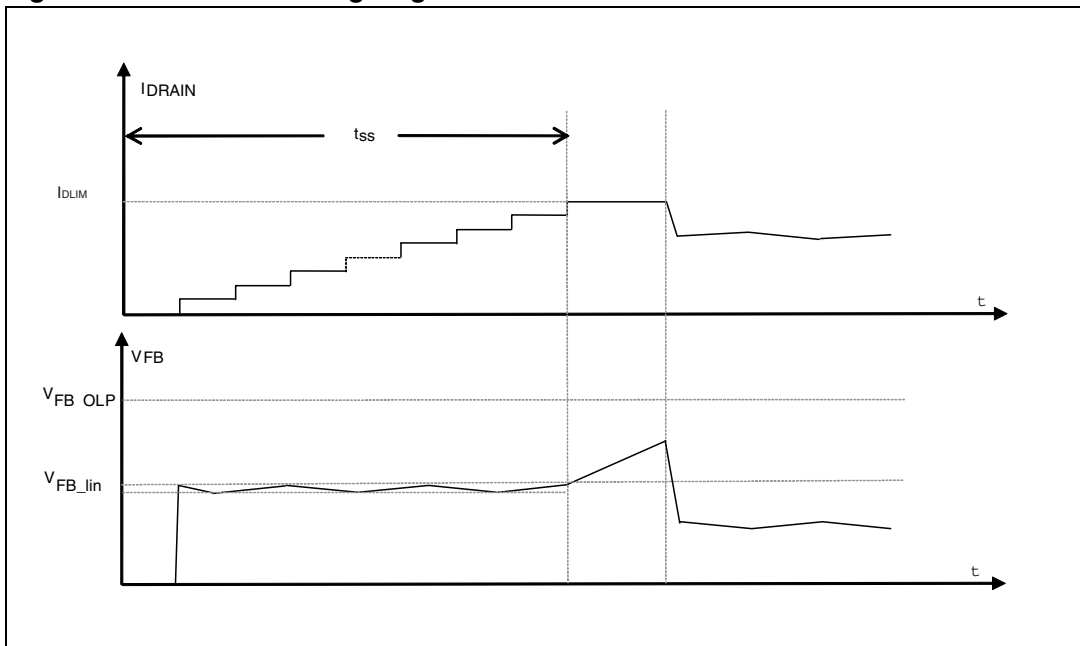

Figure 24. Soft-start: timing diagram



### 7.4 Power down operation

At converter power down, the system loses regulation as soon as the input voltage is so low that the peak current limitation is reached. The  $V_{DD}$  voltage drops and when it falls below the  $V_{DDoff}$  threshold (8 V typical) the power MOSFET is switched OFF, the energy transfers to the IC interrupted and consequently the  $V_{DD}$  voltages decreases, *Figure 23 on page 17*. Later, if the  $V_{IN}$  is lower than  $V_{DRAIN\_START}$  (80 V typical), the start up sequence is inhibited and the power down completed. This feature is useful to prevent converter’s restart attempts and ensures monotonic output voltage decay during the system power down.

### 7.5 Auto restart operation

If after a converter power down, the  $V_{IN}$  is higher than  $V_{DRAIN\_START}$ , the start up sequence is not inhibited and will be activated only when the  $V_{DD}$  voltage drops down the  $V_{DDrestart}$  threshold (4.5 V typical). This means that the HV start up current generator restarts the  $V_{DD}$  capacitor charging only when the  $V_{DD}$  voltage drops below  $V_{DDrestart}$ . The scenario above described is for instance a power down because of a fault condition. After a fault condition, the charging current is 0.6 mA (typ.) instead of the 3 mA (typ.) of a normal start up converter phase. This feature together with the low  $V_{DDrestart}$  threshold (4.5 V) ensures that, after a fault, the restart attempts of the IC has a very long repetition rate and the converter works safely with extremely low power throughput. The *Figure 25* shows the IC behavioral after a short circuit event.

**Figure 25. Timing diagram: behavior after short circuit**

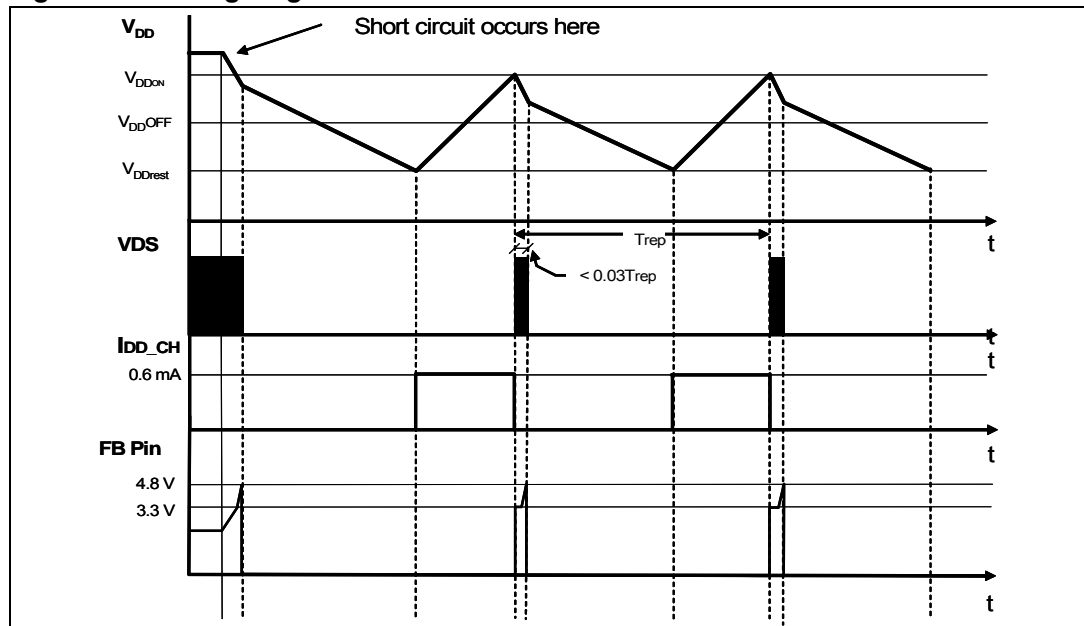

### 7.6 Oscillator

The switching frequency is internally fixed to 60 kHz or 115 kHz. In both case the switching frequency is modulated by approximately  $\pm 4$  kHz (60 kHz version) or  $\pm 8$  kHz (115 kHz version) at 250 Hz (typical) rate, so that the resulting spread-spectrum action distributes the energy of each harmonic of the switching frequency over a number of side-band harmonics having the same energy on the whole but smaller amplitudes.

## 7.7 Current mode conversion with adjustable current limit set point

The device is a current mode converter: the drain current is sensed and converted in voltage that is applied to the non inverting pin of the PWM comparator. This voltage is compared with the one on the feed-back pin through a voltage divider on cycle by cycle basis.

The VIPER17 has a default current limit value,  $I_{DLIM}$ , that the designer can adjust according the electrical specification, by the  $R_{LIM}$  resistor connected to the CONT see [Figure 16 on page 12](#).

The CONT pin has a minimum current sunk needed to activate the  $I_{DLIM}$  adjustment: without  $R_{LIM}$  or with high  $R_{LIM}$  (i.e. 100 K $\Omega$ ) the current limit is fixed to the default value (see  $I_{DLIM}$ , [Table 8 on page 8](#)).

## 7.8 Over voltage protection (OVP)

The device can monitor the converter output voltage. This operation is done by CONT pin during power MOSFET OFF-time, when the voltage generated by the auxiliary winding tracks converter's output voltage, through turn ratio  $\frac{N_{AUX}}{N_{SEC}}$ . See [Figure 26](#).

In order to perform the output voltage monitor, the CONT pin has to be connected to the aux winding through a resistor divider made up by  $R_{LIM}$  and  $R_{OVP}$  (see [Figure 21](#) and [Figure 27](#)). If the voltage applied to the CONT pin exceeds the internal 3 V reference for four consecutive times the controller recognizes an over voltage condition. This special feature uses an internal counter; that is to reduce sensitivity to noise and prevent the latch from being erroneously activated. see [Figure 26 on page 20](#). The counter is reset every time the OVP signal is not triggered in one oscillator cycle.

Referring to the [Figure 21](#), the resistors divider ratio  $k_{OVP}$  will be given by:

### Equation 2

$$k_{OVP} = \frac{V_{OVP}}{\frac{N_{AUX}}{N_{SEC}} \cdot (V_{OUTOVP} + V_{DSEC}) - V_{DAUX}}$$

### Equation 3

$$k_{OVP} = \frac{R_{LIM}}{R_{LIM} + R_{OVP}}$$

Where:

- $V_{OVP}$  is the OVP threshold (see [Table 8 on page 9](#))
- $V_{OUT\ OVP}$  is the converter output voltage value to activate the OVP set by designer
- $N_{AUX}$  is the auxiliary winding turns
- $N_{SEC}$  is the secondary winding turns
- $V_{DSEC}$  is the secondary diode forward voltage
- $V_{DAUX}$  is the auxiliary diode forward voltage
- $R_{OVP}$  together  $R_{LIM}$  make the output voltage divider

Then, fixed  $R_{LIM}$ , according to the desired  $I_{DLIM}$ , the  $R_{OVP}$  can be calculating by:

**Equation 4**

$$R_{OVP} = R_{LIM} \times \frac{1 - k_{OVP}}{k_{OVP}}$$

The resistor values will be such that the current sourced and sunk by the CONT pin be within the rated capability of the internal clamp.

**Figure 26. OVP timing diagram**

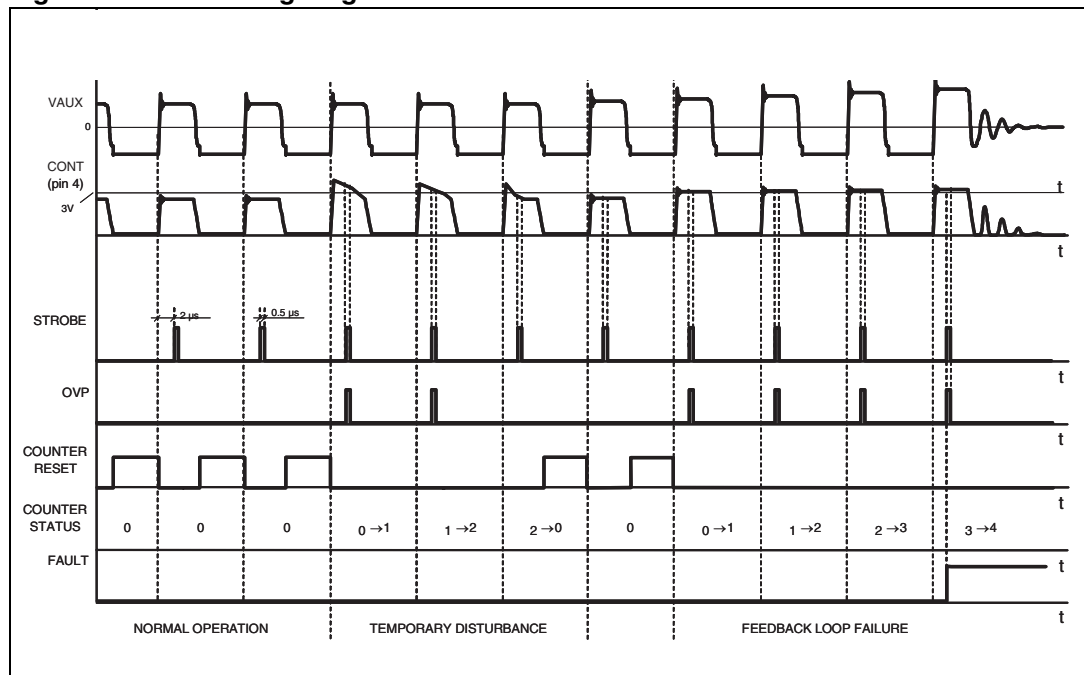

## 7.9 About CONT pin

Referring to the [Figure 27](#), through the CONT PIN, the below features can be implemented:

1. Current Limit set point
2. Over voltage protection on the converter output voltage

The [Table 9 on page 21](#) referring to the [Figure 27](#), lists the external resistance combinations needed to activate one or plus of the CONT pin functions.

**Figure 27. CONT pin configuration**

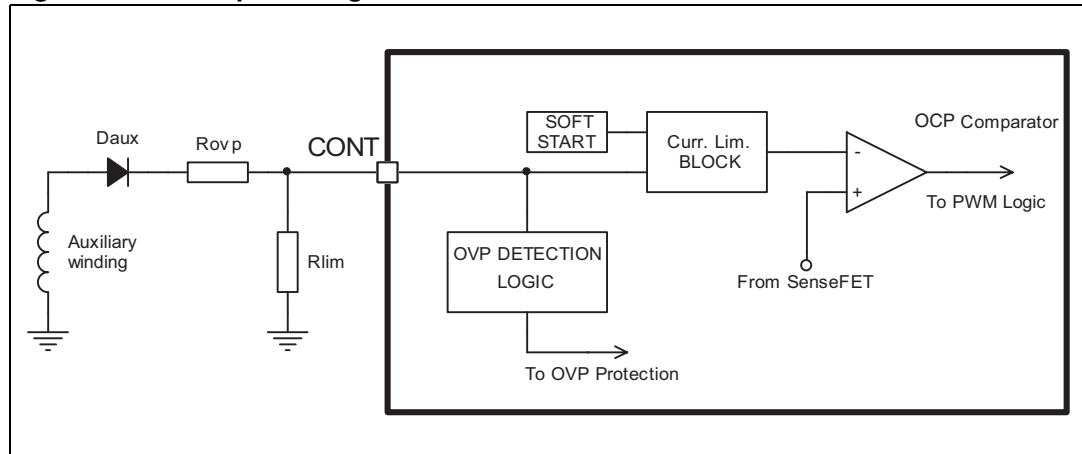

**Table 9. CONT pin configurations**

Function / component	$R_{LIM}^{(1)}$	$R_{OVP}$	$D_{AUX}$
$I_{DLIM}$ reduction	See <a href="#">Figure 8</a>	No	No
OVP	$\geq 80 K\Omega$	See <a href="#">Equation 4</a>	Yes
$I_{DLIM}$ reduction + OVP	See <a href="#">Figure 8</a>	See <a href="#">Equation 4</a>	Yes

1.  $R_{LIM}$  have to be fixed before  $R_{FF}$  and  $R_{OVP}$

## 7.10 Feed-back and over load protection (OLP)

The VIPER17 is a current mode converter: the feedback pin controls the PWM operation, controls the burst mode and activates the overload protection of the device. [Figure 28 on page 23](#) and [Figure 29](#) show the internal current mode structure.

With the feedback pin voltage between  $V_{FB\_bm}$  and  $V_{FB\_lin}$ , (respectively 0.5 V and 3.3 V, typical values) the drain current is sensed and converted in voltage that is applied to the non inverting pin of the PWM comparator.

This voltage is compared with the one on the feedback pin through a voltage divider on cycle by cycle basis. When these two voltages are equal, the PWM logic orders the switch off of the power MOSFET. The drain current is always limited to  $I_{DLIM}$  value.

In case of overload the feedback pin increases in reaction to this event and when it goes higher than  $V_{FB\_lin}$  the drain current is limited or to the default  $I_{DLIM}$  value or the one

imposed through a resistor at the CONT pin (using the  $R_{LIM}$ , see [Figure 16 on page 12](#)); the PWM comparator is disabled.

At the same time an internal current generator starts to charge the feedback capacitor ( $C_{FB}$ ) and when the feedback voltage reaches the  $V_{FB\_olp}$  threshold, the converter is turned off and the start up phase is activated with reduced value of  $I_{charge}$  to 0.6 mA.

During the first start up phase of the converter, after the soft-start up time (typical value is 8.5 ms) the output voltage could force the feedback pin voltage to rise up to the  $V_{FB\_olp}$  threshold that switches off the converter itself.

To avoid this event, the appropriate feedback network has to be selected according to the output load. More the network feedback fixes the compensation loop stability. The [Figure 28 on page 23](#) and [Figure 29](#) show the two different feedback networks.

The time from the over load detection ( $V_{FB} = V_{FB\_lin}$ ) to the device shutdown ( $V_{FB} = V_{FB\_olp}$ ) can be calculating by  $C_{FB}$  value (see [Figure 28 on page 23](#) and [Figure 29](#)), using the formula:

#### Equation 5

$$T_{OLP\_delay} = C_{FB} \times \frac{V_{FBolp} - V_{FBlin}}{3\mu A}$$

In the [Figure 28](#), the capacitor connected to FB pin ( $C_{FB}$ ) is used as part of the circuit to compensate the feedback loop but also as element to delay the OLP shut down owing to the time needed to charge the capacitor (see equation 5).

After the start up time, 8.5 ms typ value, during which the feedback voltage is fixed at  $V_{FB\_lin}$ , the output capacitor could not be at its nominal value and the controller interpret this situation as an over load condition. In this case, the OLP delay helps to avoid an incorrect device shut down during the start up.

Owing to the above considerations, the OLP delay time must be long enough to by-pass the initial output voltage transient and check the over load condition only when the output voltage is in steady state. The output transient time depends from the value of the output capacitor and from the load.

When the value of the  $C_{FB}$  capacitor calculated for the loop stability is too low and cannot ensure enough OLP delay, an alternative compensation network can be used and it is showed in [Figure 29 on page 23](#).

Using this alternative compensation network, two poles ( $f_{PFB}$ ,  $f_{PFB1}$ ) and one zero ( $f_{ZFB}$ ) are introduced by the capacitors  $C_{FB}$  and  $C_{FB1}$  and the resistor  $R_{FB1}$ .

The capacitor  $C_{FB}$  introduces a pole ( $f_{PFB}$ ) at higher frequency than  $f_{ZB}$  and  $f_{PFB1}$ . This pole is usually used to compensate the high frequency zero due to the ESR (Equivalent Series Resistor) of the output capacitance of the fly-back converter.

The mathematical expressions of these poles and zero frequency, considering the scheme in [Figure 29](#) are reported by the equations below:

#### Equation 6

$$f_{ZFB} = \frac{1}{2 \cdot \pi \cdot C_{FB1} \cdot R_{FB1}}$$

Equation 7

$$f_{PFB} = \frac{R_{FB(DYN)} + R_{FB1}}{2 \cdot \pi \cdot C_{FB} \cdot (R_{FB(DYN)} \cdot R_{FB1})}$$

Equation 8

$$f_{PFB1} = \frac{1}{2 \cdot \pi \cdot C_{FB1} \cdot (R_{FB1} + R_{FB(DYN)})}$$

The  $R_{FB(DYN)}$  is the dynamic resistance seen by the FB pin.

The  $C_{FB1}$  capacitor fixes the OLP delay and usually  $C_{FB1}$  results much higher than  $C_{FB}$ . The Equation 5 can be still used to calculate the OLP delay time but  $C_{FB1}$  has to be considered instead of  $C_{FB}$ . Using the alternative compensation network, the designer can satisfy, in all case, the loop stability and the enough OLP delay time alike.

Figure 28. FB pin configuration

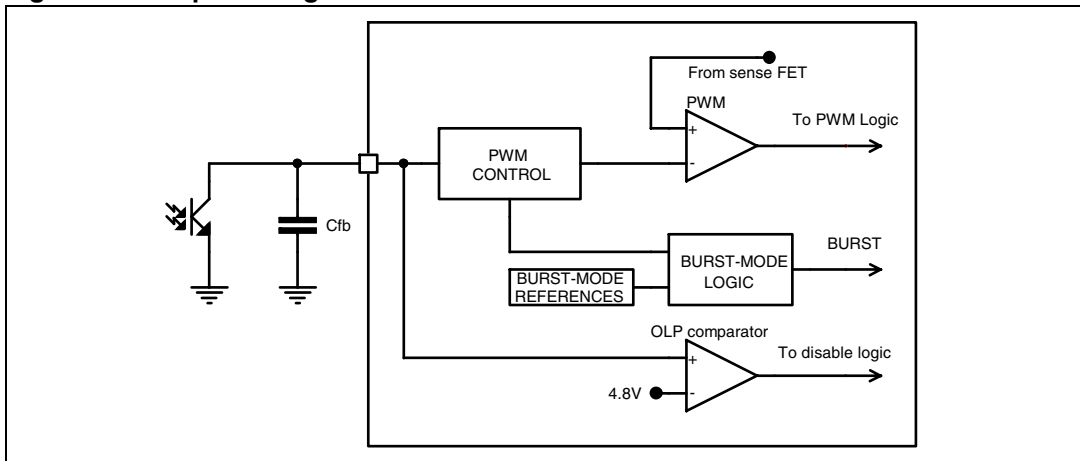
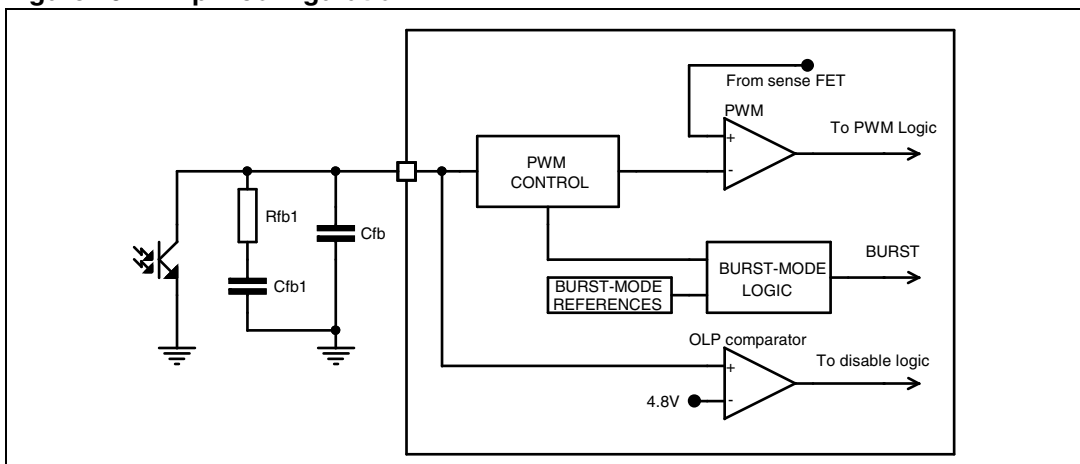

Figure 29. FB pin configuration



### 7.11 Burst-mode operation at no load or very light load

When the voltage on feedback pin falls down 50 mV below the burst mode threshold,  $V_{FBbm}$ , power MOSFET is not more allowed to be switched on. It can be switched on again if the voltage on feedback pin exceeds  $V_{FBbm}$ . The voltage on PWM comparator non inverting internal input, connected to feedback pin through a resistive voltage divider, is lower clamped to a certain value leading to a minimum value, of 90 mA (typ.) for the drain peak current.

When the load decrease the feedback loop reacts lowering the feedback pin voltage. As the voltage goes 50 mV below  $V_{FBbm}$  MOSFET stops switching. After the MOSFET stops, as a result of the feedback reaction to the energy delivery stop, the feedback pin voltage increases and exceeding  $V_{FBbm}$  threshold MOSFET the power device start switching again. *Figure 30* shows this behavior called burst mode. Systems alternates period of time where power MOSFET is switching to period of time where power MOSFET is not switching. The power delivered to output during switching periods exceeds the load power demands; the excess of power is balanced from not switching period where no power is processed. The advantage of burst mode operation is an average switching frequency much lower then the normal operation working frequency, up to some hundred of hertz, minimizing all frequency related losses.

**Figure 30. Burst mode timing diagram, light load management**

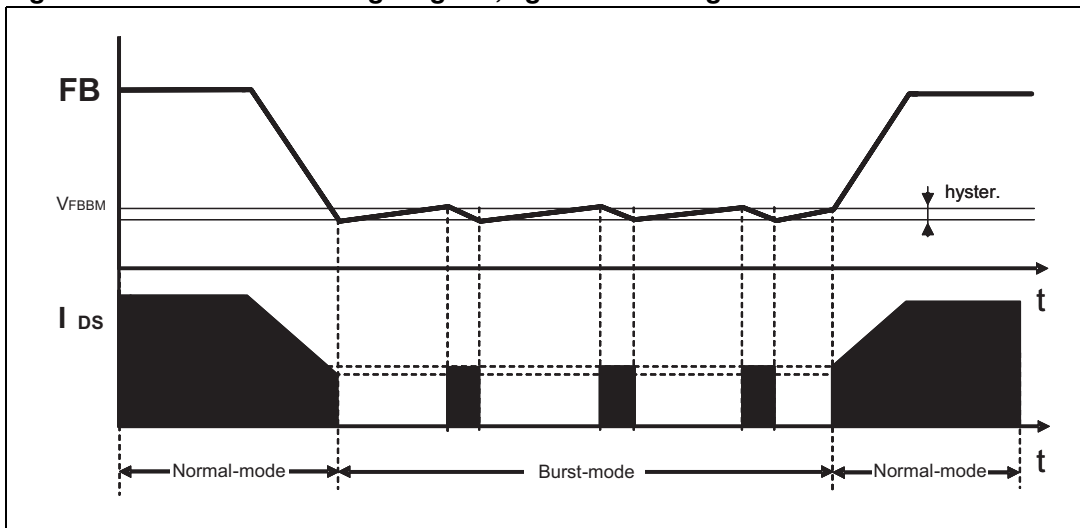



## 7.12 Brown-out protection

Brown-out protection is a not-latched shutdown function activated when a condition of mains under voltage is detected.

The Brown-out comparator is internally referenced to  $V_{BRth}$ , 0.45 V typ value, and disables the PWM if the voltage applied at the BR pin is below this internal reference. Under this condition the power MOSFET is turned off. Until the Brown out condition is present, the VDD voltage continuously oscillates between the  $V_{DDon}$  and the UVLO thresholds, as shown in the timing diagram of [Figure 31 on page 25](#). A voltage hysteresis is present to improve the noise immunity.

The switching operation is restarted as the voltage on the pin is above the reference plus the before said voltage hysteresis. See [Figure 31](#).

The Brown-out comparator is provided also with a current hysteresis,  $I_{BRhyst}$ . With this approach is possible to set the  $V_{INon}$  threshold and  $V_{INoff}$  thresholds separately, by properly choosing the resistors of the divider connect to the BR pin.

**Figure 31. Brown-out protection: BR external setting and timing diagram**

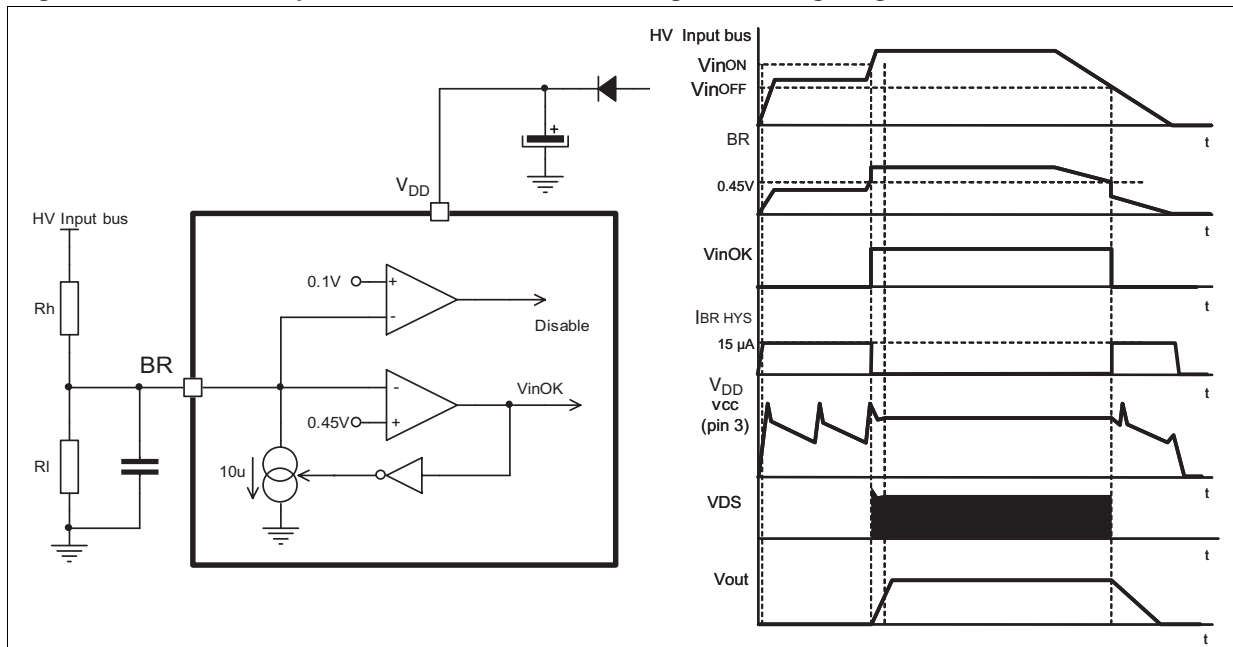

Fixed the  $V_{INon}$  and the  $V_{INoff}$  levels, with reference to [Figure 31](#), the following relationships can be established for the calculation of the resistors  $R_H$  and  $R_L$ :

### Equation 9

$$R_L = -\frac{V_{BRHYST}}{I_{BRHYST}} + \frac{V_{INon} - V_{INoff} - V_{BRHYST}}{V_{INoff} - V_{BR}} \times \frac{V_{BR}}{I_{BRHYST}}$$

**Equation 10**

$$R_H = \frac{V_{INon} - V_{INoff} - V_{BRHYST}}{I_{BRHYST}} \times \frac{R_L}{R_L + \frac{V_{BRHYST}}{I_{BRHYST}}}$$

For a proper operation of this function,  $V_{IN\ on}$  must be less than the peak voltage at minimum mains and  $V_{IN\ off}$  less than the minimum voltage on the input bulk capacitor at minimum mains and maximum load.

The BR pin is a high impedance input connected to high value resistors, thus it is prone to pick up noise, which might alter the OFF threshold when the converter operates or gives origin to undesired switch-off of the device during ESD tests.

It is possible to bypass the pin to ground with a small film capacitor (e.g. 1-10 nF) to prevent any malfunctioning of this kind.

If the Brown-out function is not used the pin has to be connected to GND.

## 7.13 2<sup>nd</sup> level over current protection and hiccup mode

The VIPER17 is protected against short circuit of the secondary rectifier, short circuit on the secondary winding or a hard-saturation of fly-back transformer. Such as anomalous condition is invoked when the drain current exceed 0.6 A typical.

To distinguish a real malfunction from a disturbance (e.g. induced during ESD tests) a “warning state” is entered after the first signal trip. If in the subsequent switching cycle the signal is not tripped, a temporary disturbance is assumed and the protection logic will be reset in its idle state; otherwise if the 2<sup>nd</sup> OCP threshold is exceeded for two consecutive switching cycles a real malfunction is assumed and the power MOSFET is turned OFF.

The shutdown condition is latched as long as the device is supplied. While it is disabled, no energy is transferred from the auxiliary winding; hence the voltage on the  $V_{DD}$  capacitor decays till the  $V_{DD}$  under voltage threshold ( $V_{DDoff}$ ), which clears the latch.

The start up HV current generator is still off, until  $V_{DD}$  voltage goes below its restart voltage,  $V_{DDrest}$ . After this condition the  $V_{DD}$  capacitor is charged again by 600 mA current, and the converter switching restart if the  $V_{DDon}$  occurs. If the fault condition is not removed the device enters in auto-restart mode. This behavioral, results in a low-frequency intermittent operation (Hiccup-mode operation), with very low stress on the power circuit. See the timing diagram of [Figure 32](#).

**Figure 32. Hiccup-mode OCP: timing diagram**

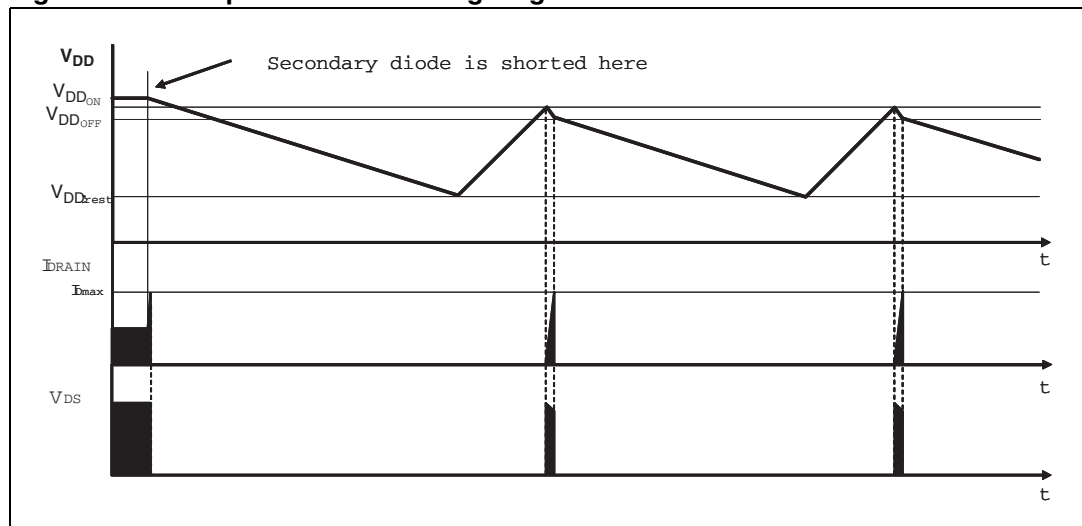

## 8 Package mechanical data

In order to meet environmental requirements, ST offers these devices in ECOPACK® packages. These packages have a lead-free second level interconnect. The category of second Level Interconnect is marked on the package and on the inner box label, in compliance with JEDEC Standard JESD97. The maximum ratings related to soldering conditions are also marked on the inner box label. ECOPACK is an ST trademark. ECOPACK specifications are available at: [www.st.com](http://www.st.com).

**Table 10. DIP-7 mechanical data**

Dim.	mm		
	Typ	Min	Max
A			5,33
A1		0,38	
A2	3,30	2,92	4,95
b	0,46	0,36	0,56
b2	1,52	1,14	1,78
c	0,25	0,20	0,36
D	9,27	9,02	10,16
E	7,87	7,62	8,26
E1	6,35	6,10	7,11
e	2,54		
eA	7,62		
eB			10,92
L	3,30	2,92	3,81
M <sup>(6)(8)</sup>	2,508		
N	0,50	0,40	0,60
N1			0,60
O <sup>(7)(8)</sup>	0,548		

- 1- The leads size is comprehensive of the thickness of the leads finishing material.
- 2- Dimensions do not include mold protrusion, not to exceed 0,25 mm in total (both side).
- 3- Package outline exclusive of metal burrs dimensions.
- 4- Datum plane "H" coincident with the bottom of lead, where lead exits body.
- 5- Ref. POA MOTHER doc. 0037880
- 6- Creepage distance > 800 V
- 7- Creepage distance 250 V
- 8- Creepage distance as shown in the 664-1 CEI / IEC standard.

Figure 33. Package dimensions

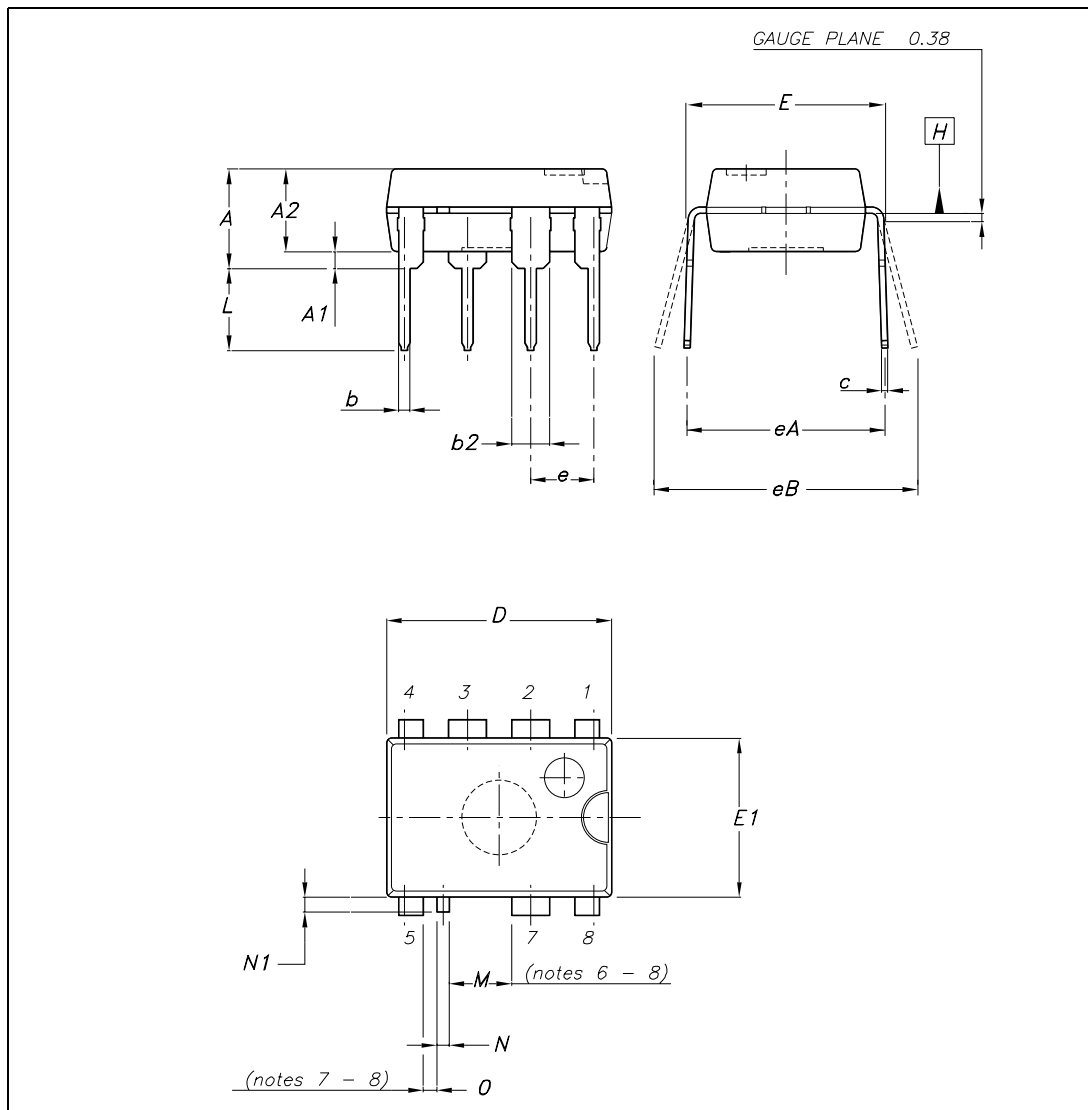
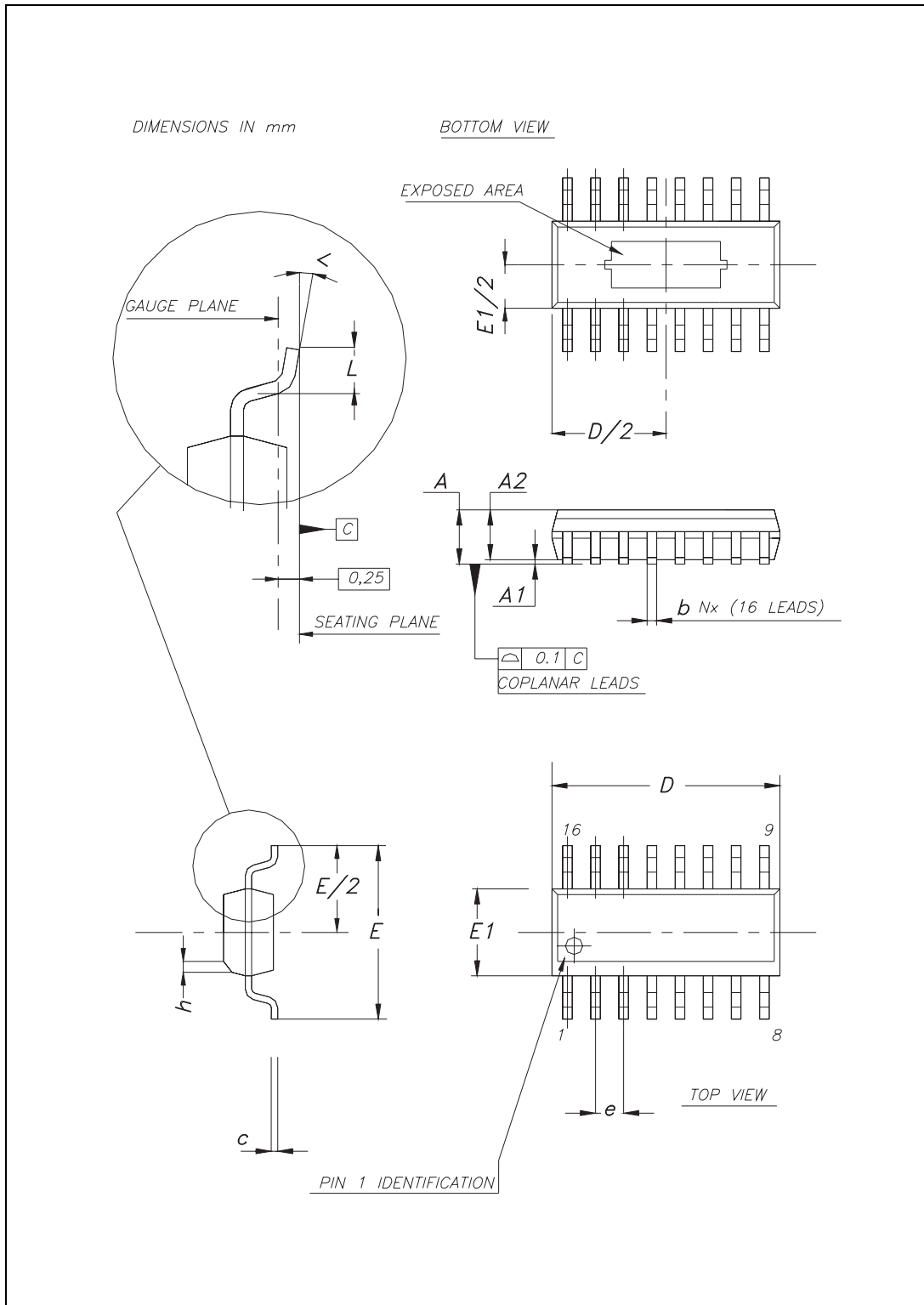

Table 11. SO16 narrow mechanical data

Dimensions			
Ref.	Databook (mm.)		
	Nom	Min	Max
A	1.63	1.55	1.73
A1	0.15	0.12	0.25
A2	1.47	1.40	1.55
b	0.41	0.31	0.49
c	0.20	0.19	0.25
D	9.93	9.80	9.98
E	5.99	5.84	6.20
E1	3.94	3.81	3.99
e	1.27		
L	0.64	0.41	0.89
<	5°	0°	8°
h	0.33	0.25	0.41

Figure 34. Package dimensions



## 9 Revision history

**Table 12. Document revision history**

Date	Revision	Changes
14-Feb-2008	1	Initial release
19-Feb-2008	2	Updated: <i>Figure 1 on page 1, Figure 3 on page 5</i>
21-Jul-2008	3	Added new SO16 package



**Please Read Carefully:**

Information in this document is provided solely in connection with ST products. STMicroelectronics NV and its subsidiaries ("ST") reserve the right to make changes, corrections, modifications or improvements, to this document, and the products and services described herein at any time, without notice.

All ST products are sold pursuant to ST's terms and conditions of sale.

Purchasers are solely responsible for the choice, selection and use of the ST products and services described herein, and ST assumes no liability whatsoever relating to the choice, selection or use of the ST products and services described herein.

No license, express or implied, by estoppel or otherwise, to any intellectual property rights is granted under this document. If any part of this document refers to any third party products or services it shall not be deemed a license grant by ST for the use of such third party products or services, or any intellectual property contained therein or considered as a warranty covering the use in any manner whatsoever of such third party products or services or any intellectual property contained therein.

**UNLESS OTHERWISE SET FORTH IN ST'S TERMS AND CONDITIONS OF SALE ST DISCLAIMS ANY EXPRESS OR IMPLIED WARRANTY WITH RESPECT TO THE USE AND/OR SALE OF ST PRODUCTS INCLUDING WITHOUT LIMITATION IMPLIED WARRANTIES OF MERCHANTABILITY, FITNESS FOR A PARTICULAR PURPOSE (AND THEIR EQUIVALENTS UNDER THE LAWS OF ANY JURISDICTION), OR INFRINGEMENT OF ANY PATENT, COPYRIGHT OR OTHER INTELLECTUAL PROPERTY RIGHT.**

**UNLESS EXPRESSLY APPROVED IN WRITING BY AN AUTHORIZED ST REPRESENTATIVE, ST PRODUCTS ARE NOT RECOMMENDED, AUTHORIZED OR WARRANTED FOR USE IN MILITARY, AIR CRAFT, SPACE, LIFE SAVING, OR LIFE SUSTAINING APPLICATIONS, NOR IN PRODUCTS OR SYSTEMS WHERE FAILURE OR MALFUNCTION MAY RESULT IN PERSONAL INJURY, DEATH, OR SEVERE PROPERTY OR ENVIRONMENTAL DAMAGE. ST PRODUCTS WHICH ARE NOT SPECIFIED AS "AUTOMOTIVE GRADE" MAY ONLY BE USED IN AUTOMOTIVE APPLICATIONS AT USER'S OWN RISK.**

Resale of ST products with provisions different from the statements and/or technical features set forth in this document shall immediately void any warranty granted by ST for the ST product or service described herein and shall not create or extend in any manner whatsoever, any liability of ST.

ST and the ST logo are trademarks or registered trademarks of ST in various countries.

Information in this document supersedes and replaces all information previously supplied.

The ST logo is a registered trademark of STMicroelectronics. All other names are the property of their respective owners.

© 2008 STMicroelectronics - All rights reserved

STMicroelectronics group of companies

Australia - Belgium - Brazil - Canada - China - Czech Republic - Finland - France - Germany - Hong Kong - India - Israel - Italy - Japan - Malaysia - Malta - Morocco - Singapore - Spain - Sweden - Switzerland - United Kingdom - United States of America

[www.st.com](http://www.st.com)