

50W SMPS DEMOBOARD

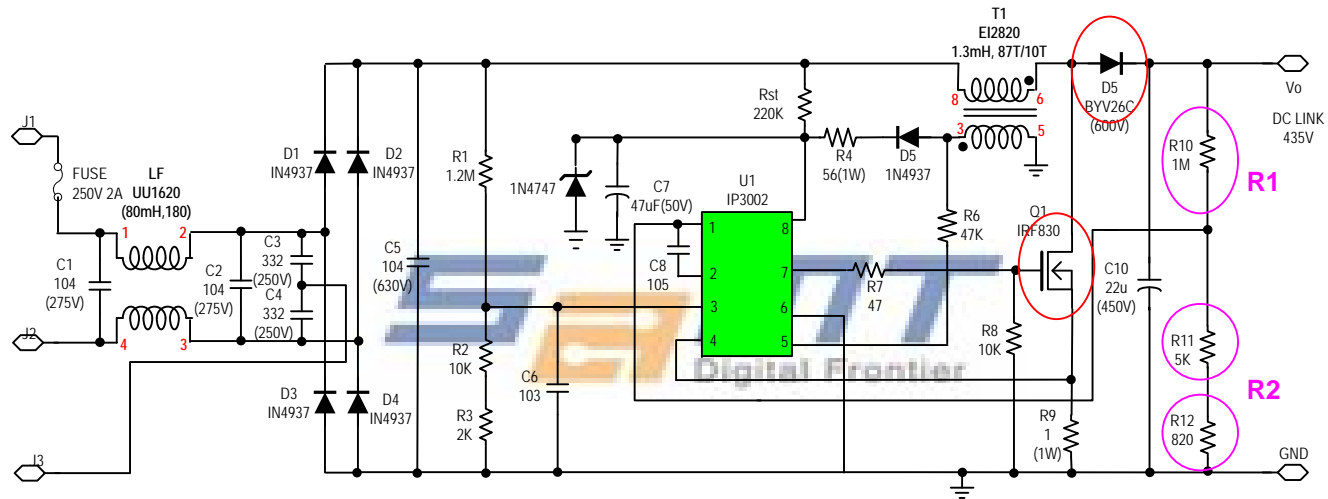

내압이 중요한 소자들 이므로 출력전압을 올릴경우 바꾸어 주어야 함.

출력 전압을 결정하는 저항 값들  $V_o = (1 + \frac{R1}{R2}) \times V_{ref}$   
\* Vref=2.5V

80W SMPS DEMOBOARD

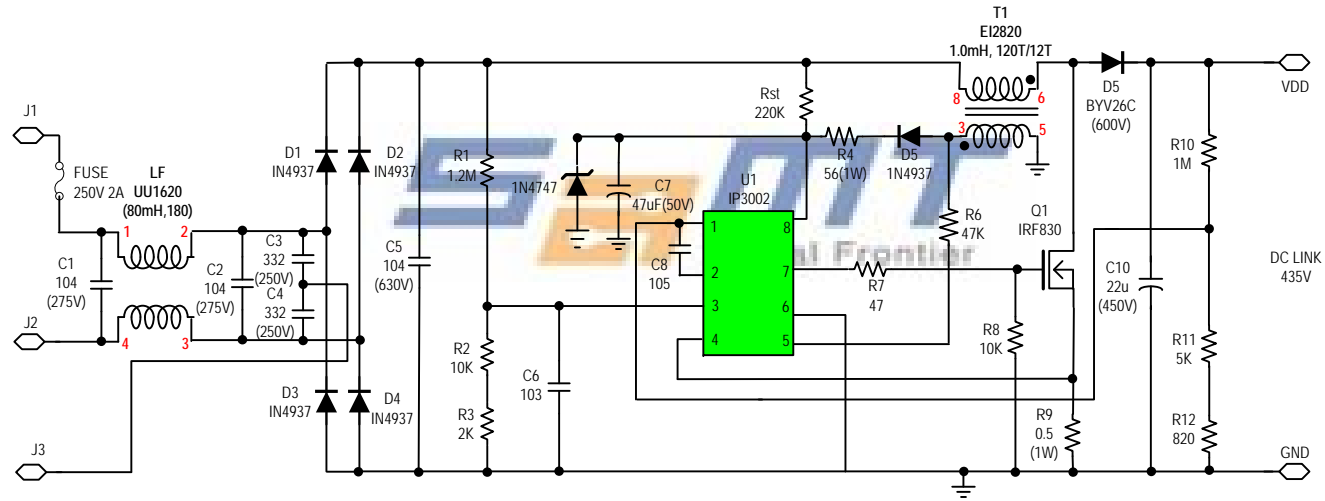

100W SMPS DEMOBOARD

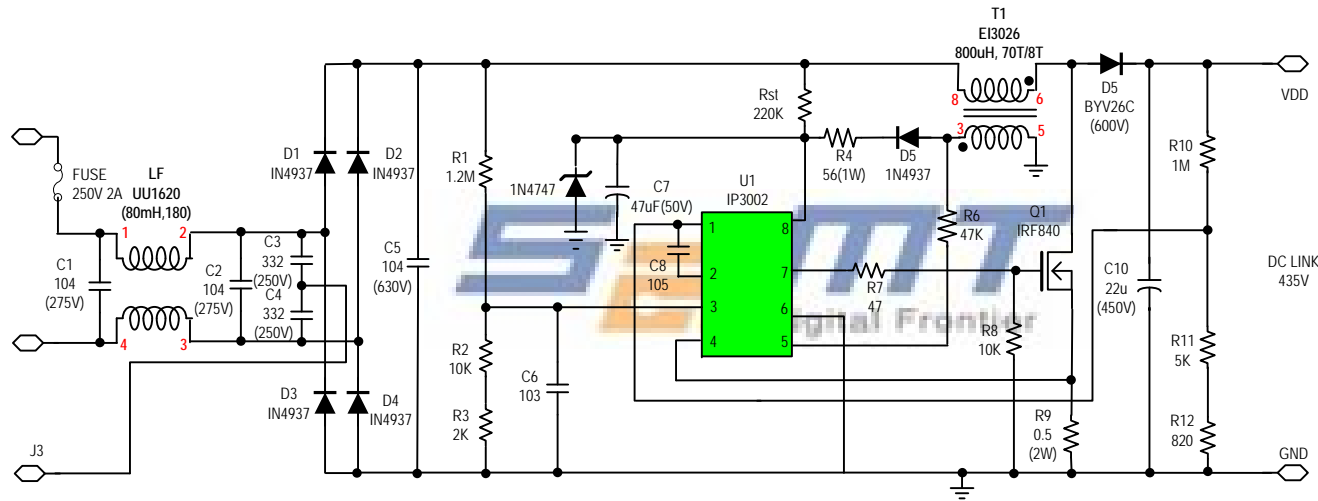

200W SMPS DEMOBOARD

