

GENERAL DESCRIPTION

The N5100 is a universal switching buffer, specifically designed to drive the power MOSFET for the various switching topology applications, it allows to receive dual input signals from a push-pull controller, and outputs total 4 driving outputs for directly driving dual N-channel and dual P-channel MOSFETs.

The N5100 features a level shift function that can shift the output potential to be different with the input potential while the device connects to different voltage source.

The N5100 features a fixed delay time control function that can transfer dual input signals from the push-pull controller become to 4 driving outputs, and successful to drive a full bridge structure power supply.

The N5100 provides 4 high current totem pole outputs that allow to be used on the multiple switching control application with single universal switching buffer.

FEATURES

- 4.5V~13.2V operating voltage
- ZVS control
- Level shift for different output potential
- Full bridge operating with a push- pull controller
- 4 high current totem pole outputs
- High efficiency
- Compatible with W98M4427 (dual outputs application)
- Low cost solution
- SOP-8 and DIP-8 Package

APPLICATIONS

- Full bridge topology
- Half bridge topology
- Push-pull topology

BLOCK DIAGRAM

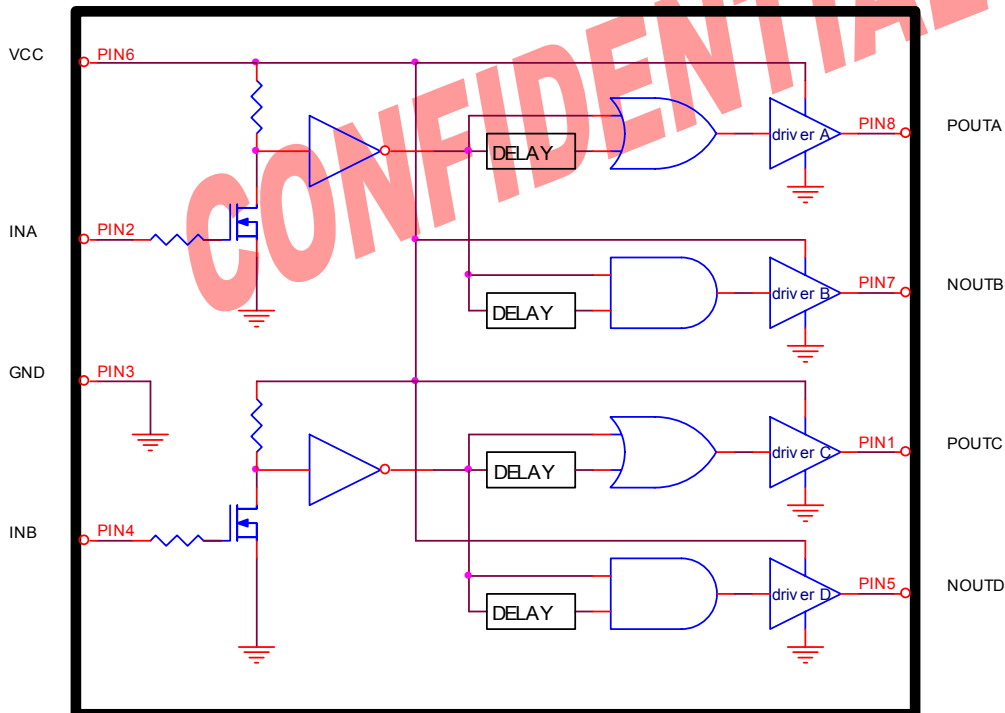

ABSOLUTE MAXIMUM RATINGS

PARAMETER	SYMBOL	LIMITS	UNITS
Power Supply Voltage	V _{CC}	15	V
Input Voltage	INA,INB	-5.0 ~V _{CC} +0.3	V
Power Dissipation at Ta =50 , SOP/DIP	PTOT	725	mW
Operating Junction Temperature	T _j	- 40 ~ 150	
Storage Temperature	TSTG	- 65 ~ 150	
Lead Temperature (Soldering) 10S	TLEAD	300	

THERMAL DATA

PARAMETER	SYMBOL	SOP- 8	DIP-8	UNIT
Thermal Resistance Junction to Ambient	θ _{ja}	53	45	/W
Thermal Resistance Junction to Case	θ _{jc}	23	15	/W

ELECTRICAL SPECIFICATIONS (- 40 Tc 85 , unless otherwise specified)

PARAMETER	SYMBOL	CONDITIONS	MIN	TYP	MAX	UNITS
INPUT SECTION						
Logic 1 input voltage	V _{IH}		2.4			V
Logic 0 input voltage	V _{IL}				0.5	V
Input Current	I _{IN}	0 VIN VCC	-1		1	uA
OUTPUT SECTION						
High Output Voltage	V _{OH}		V _{CC} -0.075			V
Low Output Voltage	V _{OL}				0.05	V
Output Resistance	R _P	current source		10		
Output Resistance	R _N	current sink		4		
Rise Time	T _r	V _{CC} =12V,Co=1000pF		35		nS
Fall Time	T _f	V _{CC} =12V,Co=1000pF		20		nS
Propagation Delay to Turn On	T _p	No load		12	25	nS
Delay Time Control	T _{delay}	No load	250	350	450	nS
POWER SUPPLY SECTION						
Supply Voltage	V _{CC}		4.5		13.2	V
Supply Current	I _{CC}	No load		2.7	4	mA

OPERATING WAVEFORM

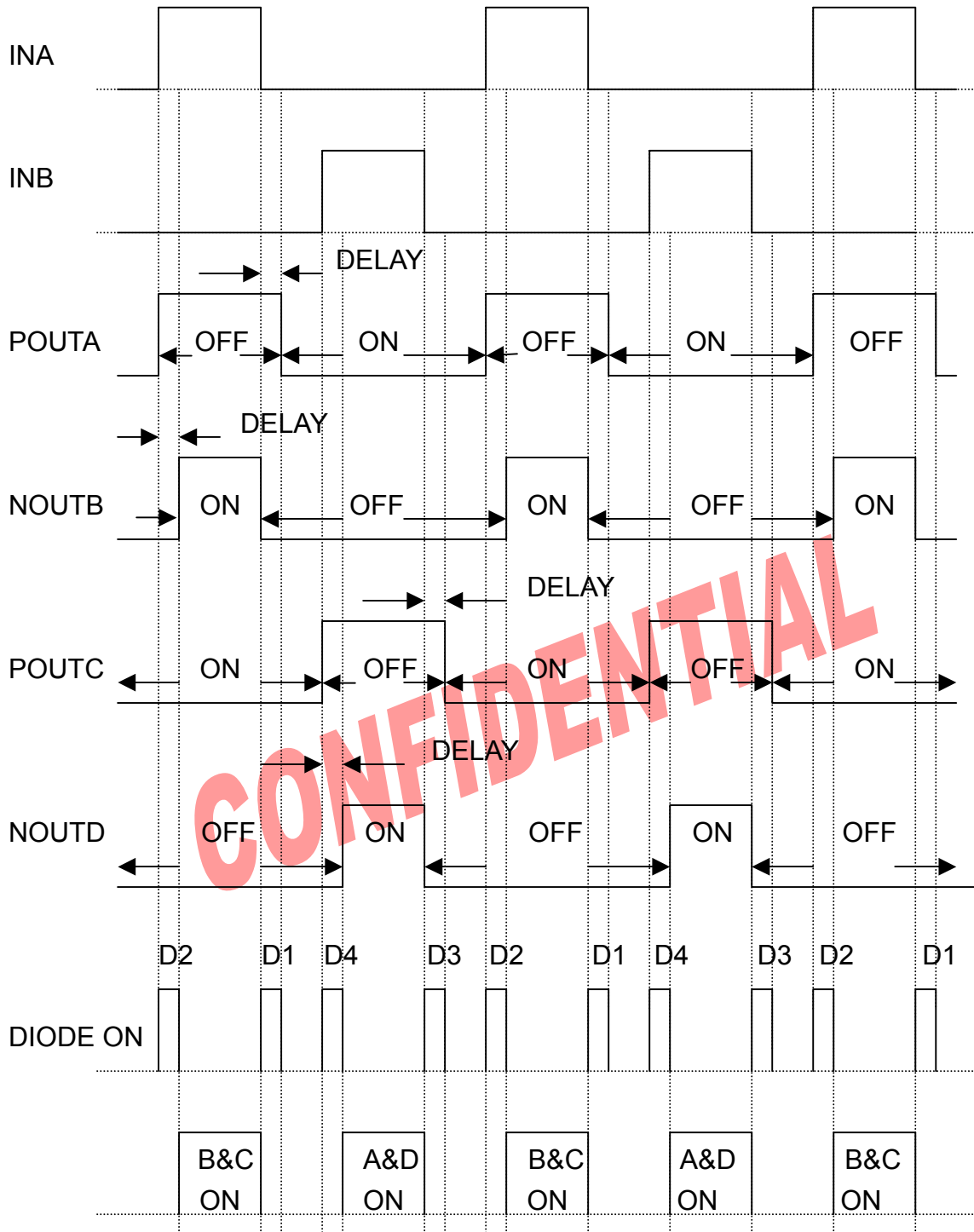

PIN CONFIGURATIONS

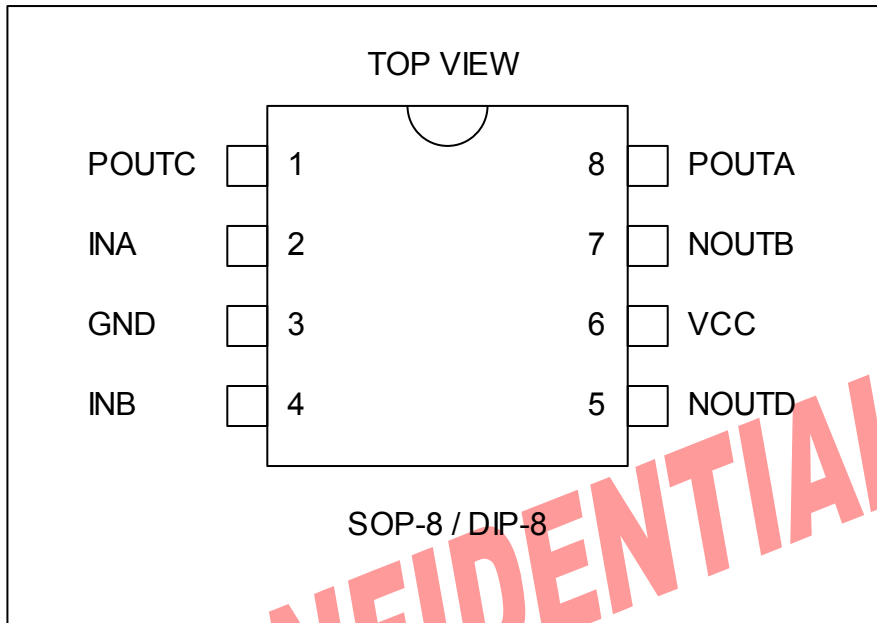

CONFIDENTIAL

PIN FUNCTIONS

NO	FUNCTION	DESCRIPTION
1	POUTC	The output of driver C that is driving the external P-channel MOSFET
2	INA	Control input A; TTL/CMOS compatible input
3	GND	GND
4	INB	Control input B; TTL/CMOS compatible input
5	NOUTD	The output of driver D that is driving the external N-channel MOSFET
6	VCC	Supply voltage input
7	NOUTB	The output of driver B that is driving the external N-channel MOSFET
8	POUTA	The output of driver A that is driving the external P-channel MOSFET

DEVICE SELECTION GUIDE

DIP-8	SOP-8
N5100P	N5100V

SOP-8 (D) MECHANICAL DATA

Dimension	mm			Dimension	mm		
	Min.	Typ.	Max.		Min.	Typ.	Max.
A	4.8		5.0	H	0.4		1.27
B	3.8		4.0	I	0.18		0.25
C	5.8		6.2	J		0.22	
D	0.33		0.51	K	0°		8°
E		1.27		L			
F			1.75	M			
G	0.1		0.3	N			

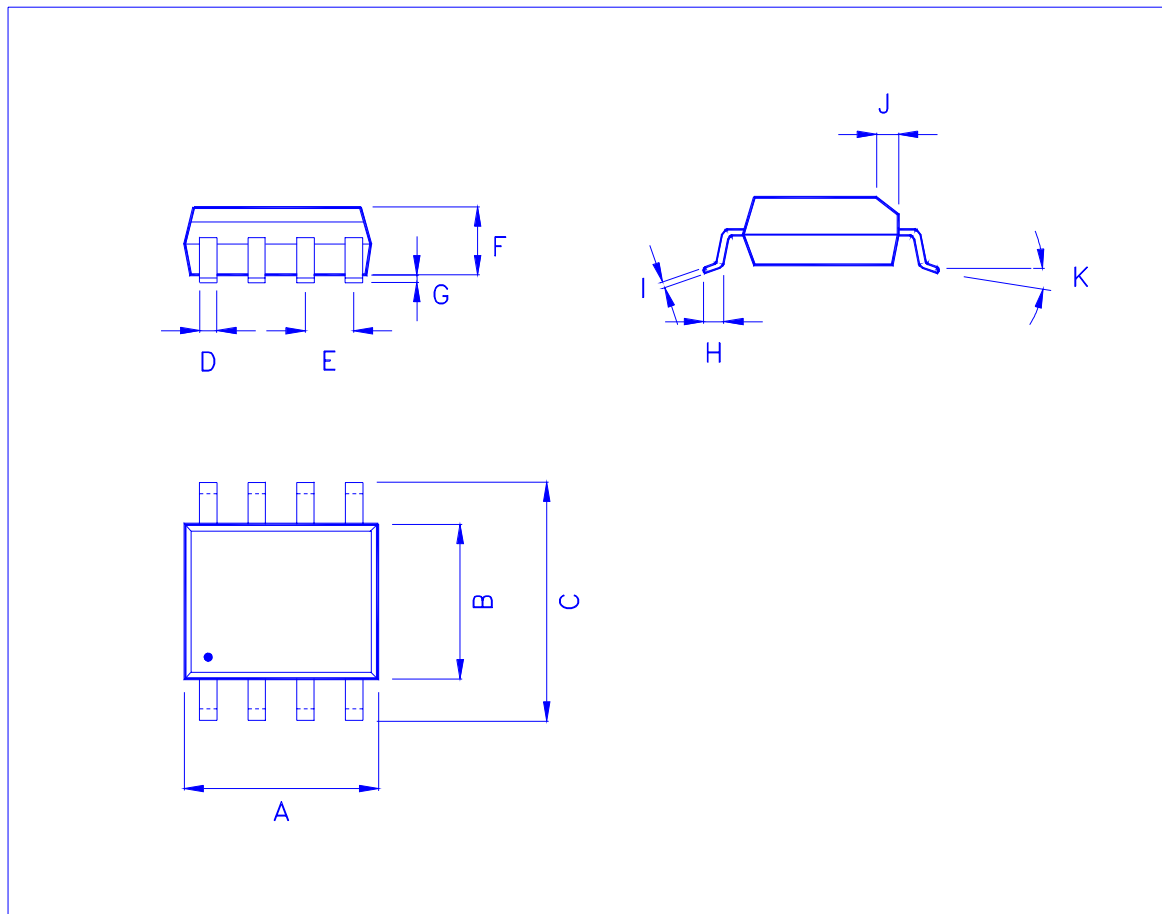

DIP-8 MECHANICAL DATA

Dimension	mm			Dimension	mm		
	Min.	Typ.	Max.		Min.	Typ.	Max.
A	8.8		9.6	H	7.95		9.75
B	6.2		7.0	I			
C	0.35	0.45	0.55	J			
D		2.54		K			
E	0.5		0.8	L			
F	3.05	3.28	3.56	M			
G	7.48	7.62	8.13	N			

