

GENERAL DESCRIPTION

The PT4107 is a high voltage buck control IC for constant LED current regulation. It allows efficient operation of High Brightness (HB) LEDs from voltage sources ranging from 18VDC up to 450VDC. The PT4107 controls an external MOSFET at fixed switching frequency from 25 kHz to 200 kHz. The frequency can be programmed using an external resistor. A proprietary peak current control method keeps constant average LED currents for wide input and output ranges. The output current can be programmed from a few milliamps up to more than 1A.

The output current on an LED string can be programmed to any value between zero and its maximum value by applying an external control voltage at the linear dimming control input of the PT4107. Moreover, PT4107 provides a low-frequency PWM dimming input that can accept an external control signal with duty ratio of 0-100% and a frequency of up to a few kilohertz.

Frequency jittering is used to reduce the EMI.

FEATURES

- Proprietary constant-current control.
- Wide input range from 18V to 450V
- Applications from a few mA to more than 1A Output
- LED string up to hundreds of diodes
- PWM Low-Frequency Dimming via Enable pin
- Linear Dimming via LD pin
- Frequency jittering for better EMI performance
- Programmable Over temp Protection (OTP)

APPLICATION

- AC/DC LED Driver applications
- RGB Backlighting LED Driver
- Signal and Decorative LED lighting

ORDERING INFORMATION

PACKAGE	TEMPERATURE RANGE	ORDERING PART NUMBER	TRANSPORT MEDIA	MARKING
SOP-8	-40 °C to 85 °C	PT4107ESOP	Tape and Reel	PT4107 xxxxxX
DIP-8	-40 °C to 85 °C	PT4107EDIP	Tape and Reel	PT4107 xxxxxX

Note:

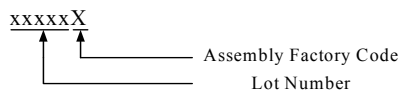

TYPICAL APPLICATION CIRCUIT

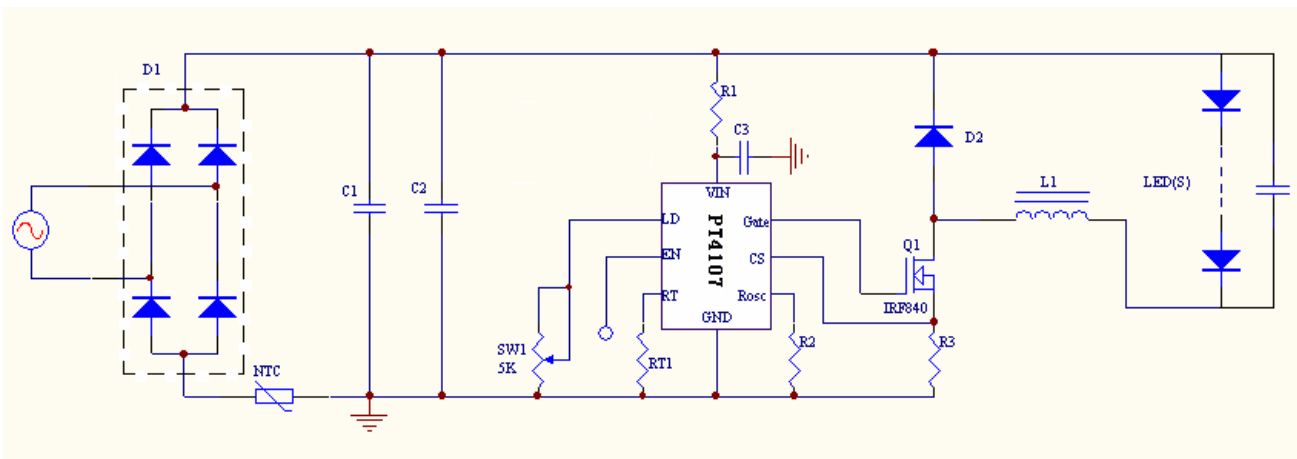

PIN ASSIGNMENT

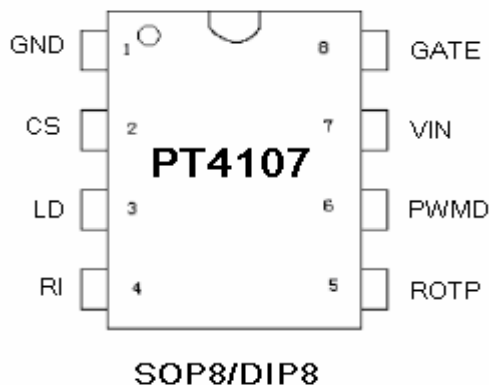

PIN DESCRIPTIONS

SOP8/DIP-8 PIN No.	PIN NAMES	DESCRIPTION
1	GND	Device ground
2	CS	Senses LED string current
3	LD	Linear dimming by changing the current limit threshold at current sense comparator
4	RI	Oscillator control. A resistor connected between this pin and ground sets the PWM frequency
5	ROTP	Temperature sensing input pin. Connected through an NTC resistor to GND. Once the voltage of the ROTP pin drops below a pre-defined value, PWM output will be disabled
6	PWMD	Low frequency PWM dimming pin, also Enable input. Internal 100kohm pull-up to 5 V
7	VIN	Input Voltage 18V to 450VDC connected by a resistor
8	GATE	Drives the gate of the external MOSFET

ABSOLUTE MAXIMUM RATINGS (note1)

SYMBOL	ITEMS	VALUE	UNIT
V_{IN}	Supply Voltage	-0.3~30	V
GATE	Drives the gate of the external MOSFET	-0.3~20	V
	Other pins voltage	-0.3~6	V
$I_{VIN(MAX)}$	Max. Input Current	10	mA
P_{DMAX}	Power Dissipation (Note 2)	Internally Limited	W
P_{TR1}	Thermal Resistance, SOP-8 θ_{JA}	105	°C/W
P_{TR2}	Thermal Resistance, DIP-8 θ_{JA}	90	°C/W
T_J	Operation Junction Temperature Range	-40 to 125	°C
T_{STG}	Storage Temperature	-55 to 150	°C

	ESD Susceptibility (Note 3)	2	kV
--	-----------------------------	---	----

RECOMMENDED OPERATING RANGE

SYMBOL	ITEMS	VALUE	UNIT
V_{IN}	V_{DD} Supply Voltage	0 ~ 20	V
	Other pins	0 ~ 5	V
T_{OPT}	Operating Temperature	-40 to +85	°C

Note 1: Absolute Maximum Ratings indicate limits beyond which damage to the device may occur. Recommended Operating Range indicates conditions for which the device is functional, but do not guarantee specific performance limits. Electrical Characteristics state DC and AC electrical specifications under particular test conditions which guarantee specific performance limits. This assumes that the device is within the Operating Range. Specifications are not guaranteed for parameters where no limit is given, however, the typical value is a good indication of device performance.

Note 2: The maximum power dissipation must be derated at elevated temperatures and is dictated by T_{JMAX} , θ_{JA} , and the ambient temperature T_A . The maximum allowable power dissipation is $P_{DMAX} = (T_{JMAX} - T_A) / \theta_{JA}$ or the number given in Absolute Maximum Ratings, whichever is lower.

Note 3: Human body model, 100pF discharged through a 1.5k Ω resistor.

ELECTRICAL CHARACTERISTICS (Note 4, 5)

The following specifications apply for $V_{IN}=16V$, $T_A=25^\circ C$, unless specified otherwise.

SYMBOL	ITEMS	CONDITIONS	MIN.	TYP.	MAX.	UNIT
I_{VIN_START}	V_{IN} start up current	$V_{IN}=15V$, $R_I=300k$		3	10	μA
I_{VIN_OPER}	V_{IN} operation current	$V_{IN}=15V$, $R_I=300k$, GATE floated			1	mA
V_{IN_clamp}	Maximal pin V_{IN} voltage			20		V
UVLO (H)	V_{IN} Under Voltage Lockout Exit	V_{IN} rising	15.5	16.5	17.5	V
UVLO (L)	V_{IN} Under Voltage Lockout Enter	V_{IN} falling	9.5	10.5	11.5	V
$V_{EN(lo)}$	PIN PWMD input low voltage				0.6	V
$V_{EN(hi)}$	PIN PWMD input high voltage		2.4			V
R_{EN}	PIN PWMD pull-up resistance			100		k Ω
V_{CS}	Current sense pull-in threshold voltage	V_{CS} Falling from 600mV	225	250	275	mV
V_{OL}	GATE Output Low Level	$V_{IN}=16V$, $I_o=-20mA$			0.3	V
V_{OH}	GATE Output High Level	$V_{IN}=16V$, $I_o=20mA$	11			V
V_{G_clamp}	Output Clamp			18		V

**Universal High Brightness LED Driver
with improved current regulation and EMI performance**

T_r	Output Rising Time	$V_{IN}=16V, CL=1nF$		120		ns
T_f	Output Falling Time	$V_{IN}=16V, CL=1nF$		50		ns
F_{OSC}	Oscillator frequency	RI=1.2M RI=300k	20 80	25 100	30 120	kHZ
D_{MAX}	Maximum PWM duty cycle			90		%
V_{LD}	Linear Dimming pin voltage range		0		500	mV
R_{LD}	Linear Dimming pin pull-up resistance			100		k Ω
T_{BLK}	Current sense blanking interval			215		ns
T_{DLY}	Delay from CS trip to GATE low				300	ns
Δf_{OSC}	Frequency Modulation range over Base Frequency		-3		+3	%
$f_{jittering}$	Modulation Freq.	RI=300k		32		Hz
I_{ROTP}	Output current of pin R_{OTP}	RI=300k		80		μA
V_{OTP}	Threshold voltage for OTP			1.0		V

Note 4: Typical parameters are measured at 25°C and represent the parametric norm.

Note 5: Datasheet min/max specification limits are guaranteed by design, test, or statistical analysis.

BLOCK DIAGRAM

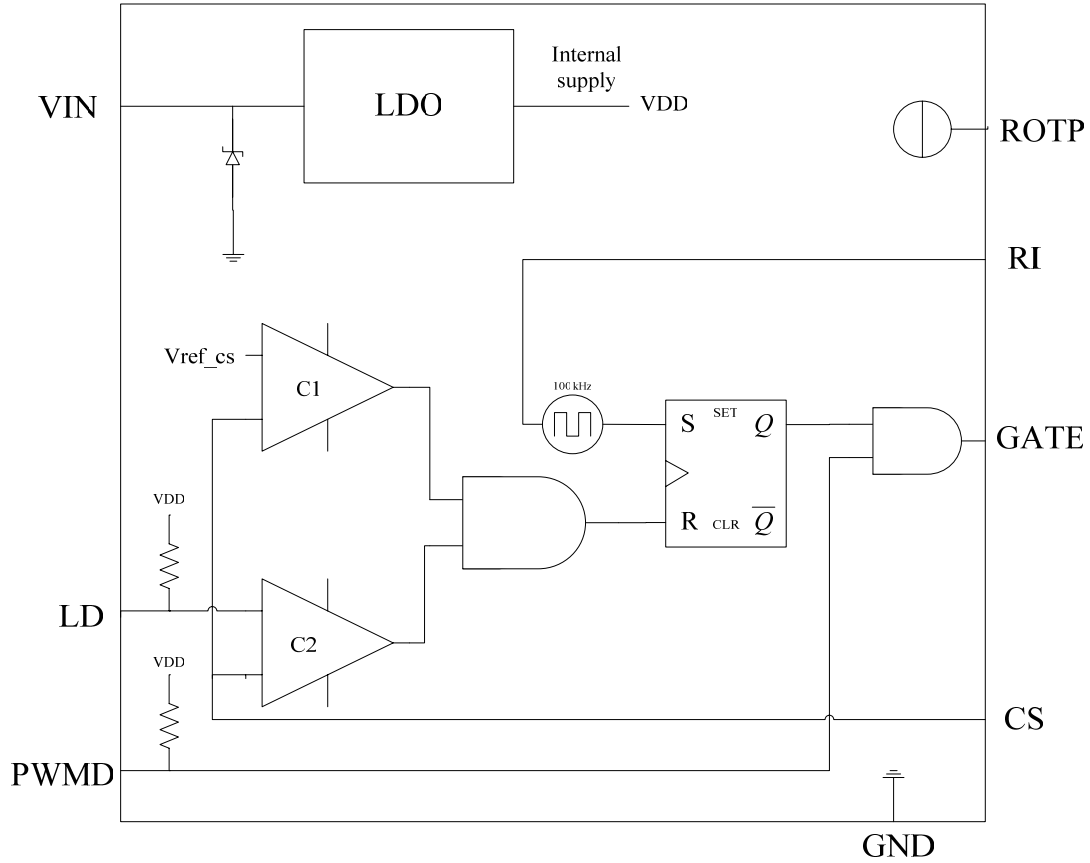

OPERATION DESCRIPTION

PT4107 is a high voltage buck controller for LED driver. The high input voltage from the rectified 110VAC or 220VAC is clamped to about 20V by an external resistor and an internal Zener. When the voltage at the V_{IN} pin exceeds the UVLO threshold the gate drive is enabled. The output current is controlled by means of limiting peak current in the external power MOSFET. A current sense resistor is connected in series with the source terminal of the MOSFET. The voltage from the sense resistor is applied to the CS pin of the PT4107. When the voltage at CS pin exceeds a peak current sense voltage threshold, the gate drive signal terminates, and the power MOSFET turns off. The threshold is internally set, or it can be programmed externally by applying voltage to the LD pin. When soft start is required, a capacitor can be connected to the LD pin to allow this voltage to ramp at a desired rate, therefore, assuring that output current of the LED ramps gradually.

LED Current Control

The peak current of the LED is programmed by an external resistor connected to CS pin. And the peak current is changed adaptively at different input and output to get the constant average LED current. The peak current I_p^*

$$I_p^* = \frac{V_{ref_cs}}{R_{cs}} + I_{pd} = \frac{V_{ref} \times (1 + 0.8 \times D) + 8 \times [(V_{IN} - V_{DD}) / R1 - I_{DD}]}{R_{cs}} + I_{pd} \quad (1)$$

Where $V_{ref} = 250\text{mV}$, $D = \frac{V_{OUT}}{V_{IN}}$ is the duty cycle of the controller, V_{IN} is the rectified voltage from the AC, $V_{DD} = 20\text{V}$, $R1$ is the start up resistor connected between V_{IN} and V_{DD} , I_{DD} is the operating current dependent on the operating frequency and the MOSFET connected to GATE. It increases with operating frequency and gate capacitance of the MOSFET. It is about 2mA when 4N60 is used at 100 kHz operating frequency.

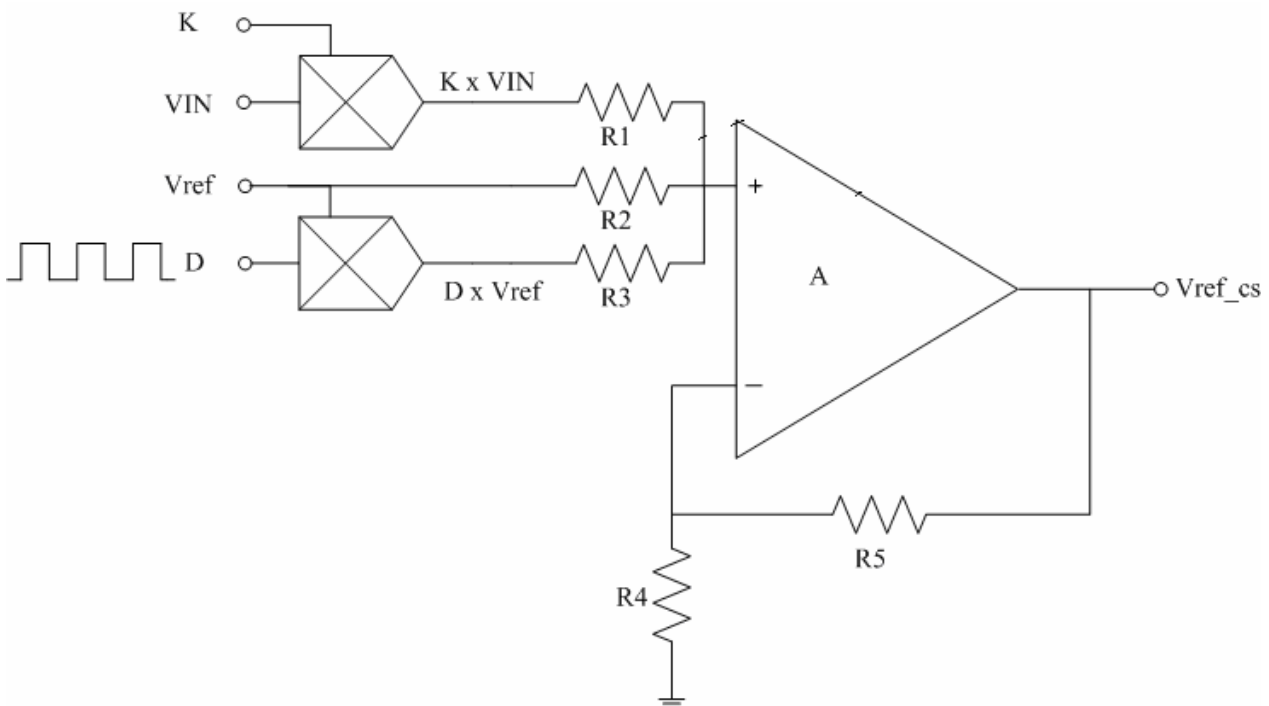

And I_{pd} is the additional current due to the system delay. Normally the system delay is about 300 ns.

$$I_{pd} = \frac{(V_{IN} - n \times V_{LED}) \times T_d}{L \times R_{cs}} \quad (2)$$

The changed peak current is used to compensate the different inductor ripple current at different application to make sure the average LED current is constant at a wide range of input and output voltage.

After the peak current compensation, the LED current is programming easily when the inductor, operating frequency, and startup resistor is determined.

$$I_{LED} = \frac{V_{ref}}{R_{cs}} = \frac{250mV}{R_{cs}} \quad (3)$$

The application note provides more information how to choose them.

Dimming

The PT4107 can drive up to tens of High-Brightness (HB) LEDs or multiple strings of HB LEDs. The LED arrays can be configured as a series or series/parallel connection. The PT4107 regulates constant current that ensures controlled brightness and spectrum of the LEDs, and extends their lifetime. The PT4107 features an enable pin (PWMD) that allows PWM control of brightness. The PT4107 can also control brightness of LEDs by programming continuous output current of the LED driver (so-called linear dimming) when a control voltage is applied to the LD pin.

Thermal Protection

A thermistor (NTC) connected to R_{OTP} pin can prevent the LED from overheating. An internal current

$$I_{OTP} = \frac{24000}{RI[k\Omega]} \mu A$$
 is sourcing from the R_{OTP} pin. The current is about 80uA when RI is equal to 300k Ohm. And

the controller will shut down the system when the voltage of R_{OTP} pin is less than 1 V. When the overheating situation is released, the system recovers to normal operation.

Frequency shuffling for EMI improvement

The frequency jittering (switching frequency modulation) is implemented in PT4107. The oscillator frequency is modulated with a random source so that the tone energy is spread out. The spread spectrum minimizes the conduction band EMI and therefore reduces system design challenge.

Enable

The PT4107 can be turned off by pulling the PWM_D pin to ground. When disabled, the PT4107 draws quiescent current of less than 0.5mA.

Leading Edge Blanking

Each time when the power MOSFET is switched on, a turn-on spike will inevitably occur on the sense-resistor. To avoid premature termination of the switching pulse, a 300 ns leading-edge blanking time is built in. Conventional RC filtering can therefore be omitted. During this blanking period, the current-limit comparator is disabled and it cannot switch off the gate driver.

APPLICATION INFORMATION

This section discusses the design of a buck-based LED driver using the PT4107 with the help of an off-line application example.

For example:

AC Input Voltage Range: $V_{nom,ac}=220V$ rms $V_{min,ac}=176V$ rms $V_{max,ac}=264V$ rms $freq=50Hz$

Expected LED string voltage: $V_{o,min}=30V$ $V_{o,max}=70V$

Stabilized LED CURRENT: $I_{o,max}=350mA$

Expected Efficiency: $\eta=90\%$

Switching Frequency and resistor (RI)

The operating frequency of the oscillator is programmed between 25 and 200 kHz using an external resistor connected to the RT pin:

$$FOSC = 30000 / (RI [k\Omega]) [kHz]$$

Normally, setting the operating frequency to 100 kHz and the resistor is 300 k Ω .

When the output LED strings are less than 5, lower operating frequency is used.

Input Diode Bridge (D1) and the thermistor (NTC)

The voltage rating of the diode bridge will depend on the maximum value of the input voltage. The current rating will depend on the maximum average current drawn by the converter.

$$V_{bridge} = 1.5 \times (\sqrt{2} \times V_{max,ac}) \quad (4)$$

$$I_{bridge} = \frac{V_{o,max} \times I_{o,max}}{V_{min} \times \eta} \quad (5)$$

The 1.5 factor in equation (4) is a 50% safety margin. For this design, choose a 400V, 1A diode bridges.

Placing a thermistor (or resistor) in series with input bridge rectifier will effectively limit the inrush charging current to input bulk capacitor C1 during the initial start-up of the converter. Except this useful action during very short time interval, such a series element creates unnecessary power loss dissipation during normal operation of the converter, and must be minimized. A good rule of thumb is that the thermistor should limit the inrush current to not more than five times the steady state current as given by equation (5), assuming maximum voltage is applied. The required cold resistance is:

$$R_{cold} = \frac{V_{bridge}}{5 \times I_{bridge}} \quad (6)$$

Choose a thermistor with a resistance around 300 Ω and rms current greater than 0.2A for the application.

Input Capacitors (C1 and C2)

The first design criterion to meet is that the maximum LED string voltage is should be less than half the minimum input voltage to avoid having to implement a special loop compensation technique

For this example, the minimum rectified voltage should be:

$$V_{\min,dc} = 2 \times V_{o,\max} = 140V \quad (7)$$

The hold-up and input filter capacitor required at the diode bridge output have to be calculated at the minimum AC input voltage. The minimum capacitor value can be calculated as:

$$C1 \geq \frac{V_{o,\max} \times I_{o,\max}}{(2 \times V_{\min,ac} - V_{\min,ac}) \times \eta \times freq} \quad (8)$$

In this example, $C1 > 12.8\mu F$

The voltage rating of the capacitor should be more than the peak input voltage with 10-12% safety margin.

$$V_{\max,cap} \geq \sqrt{2} \times V_{\max,ac} = 371V \quad (9)$$

Choose a 22 μF , 400V electrolytic capacitor.

FET (Q1) and Diode (D2)

The peak voltage seen by the FET is equal to the maximum input voltage. Using a 50% safety rating,

$$V_{FET} = 1.5 \times (\sqrt{2} \times V_{ac,nom}) \quad (10)$$

The maximum RMS current through the FET depends on the maximum duty cycle, which is 50% by design.

Hence, the current rating of the FET is

$$I_{FET} \approx I_{o,\max} \times \sqrt{2} \quad (11)$$

For this application, chose a MOSFET 600V, 1 to 2 A. 2N60 or 4N60 are good choice.

The peak voltage rating of the diode is the same as the FET. The average current through the diode is:

$$I_{diode} = I_{o,\max} = 350mA \quad (12)$$

For this example, 600V/1A is ok. Fast recovery diode is recommended.

The Startup Resistor (R1) and Hold Capacitor (C3)

$$R1 = \frac{\sqrt{2}V_{ac,nom} - V_{DD,nom}}{I_{IN}} \quad (13)$$

Calculate resistor R1 power dissipation:

$$P_{R1} = I_{in,\max}^2 \times R1 \quad (14)$$

Typically, the range of the startup resistor is 56k to 100k with 2W for 220V AC and 33k to 56k with 1W for 110V AC.

For this example, 75k/2W power resistor is used. A 1 μF 30V hold capacitor is ok for PT4107.

The thermal protection resistance (RT1)

An NTC thermistor RT1 can be connected from pin RT to ground. A constant current I_{RT} is output from pin RT. The voltage on RT pin can be expressed as $V_{RT} = I_{RT} \times RT1$, The system will be shut down when the voltage of the pin RT as low as 1V.

$$I_{RT} = 24000 / (RI [k\Omega]) [\mu A]$$

Choose the Inductor (L1)

The inductor value depends on the ripple current in the LEDs. The LED current decreases with the ripple current without compensation. However, a proprietary current compensation technique is used in PT4107 to overcome this problem. The average LED current doesn't change with the ripple current at a wide range of output voltage. The inductor can be smaller and the total cost can be lower. A bypass capacitor is used to reduce ripple current if necessary.

If the operating frequency is set to 100 kHz, the value of inductor is shown in table 1. It's valid at a wide range of output voltage from 10 LEDs to 20 LEDs if the input voltage is 220V AC.

Table 1

IOUT	220V AC	110V AC
350mA	2000uH	1000uH
750mA	1000uH	560uH
1000mA	680uH	390uH

Normally, the value of inductor decreases with the LED current and operating frequency. It's not recommended the higher operating frequency is used due to higher switching loss.

For this example, 2mH/500mA inductor is ok.

Choose the Current Sense Resistor (R3)

The sense resistor value is given by:

$$R3 = \frac{0.25}{I_{LED}} = 0.72\Omega \quad (15)$$

Calculate also resistor power dissipation:

$$P_{R3} = I_{LED}^2 \times R3 = 0.088W \quad (16)$$

A 0.1W 0.72Ω resistor is good for this application.

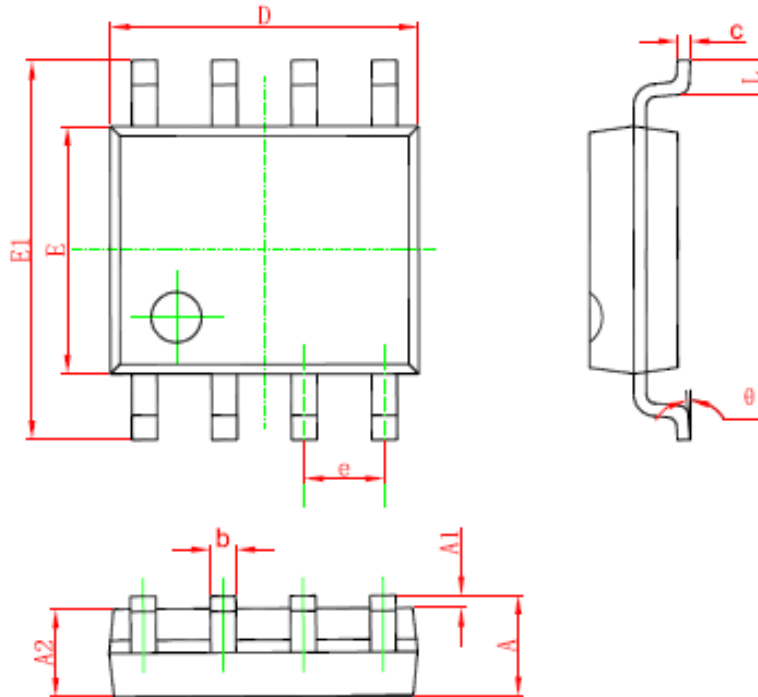
PACKAGE INFORMATION
SOP-8 Package

Symbol	Dimensions In Millimeters		Dimensions In Inches	
	Min	Max	Min	Max
A	1.350	1.750	0.053	0.069
A1	0.100	0.250	0.004	0.010
A2	1.350	1.550	0.053	0.061
b	0.330	0.510	0.013	0.020
c	0.170	0.250	0.006	0.010
D	4.700	5.100	0.185	0.200
E	3.800	4.000	0.150	0.157
E1	5.800	6.200	0.228	0.244
e	1.270 (BSC)		0.050 (BSC)	
L	0.400	1.270	0.016	0.050
θ	0°	8°	0°	8°