

Standalone Linear Li-Ion Battery Charger

Description

KF4054 is a complete constant-current & constant voltage linear charger for single cell lithium-ion batteries. Its SOT-23 package and low external component count make KF4054 ideally suited for portable applications. Furthermore, the KF4054 is specifically designed to work within USB power specification. At the same time, KF4054 can also be used in the standalone lithium-ion battery charger.

No external sense resistor is needed, and no blocking diode is required due to the internal MOSFET architecture. Thermal feedback regulates the charge current to limit the die temperature during high power operation or high ambient temperature. The charge voltage is fixed at 4.2V, and the charge current can be programmed externally with a single resistor. The KF4054 automatically terminates the charge cycle when the charge current drops to 1/10th the programmed value after the final float voltage is reached.

When the input supply (wall adapter or USB supply) is removed, the KF4054 automatically enters a low current stage, dropping the battery drain current to less than 2uA. The KF4054 can be put into shutdown mode, reducing the supply current to 25uA.

Other features include charge current monitor, undervoltage lockout, automatic recharge and a status pin to indicate charge termination and the presence of an input voltage.

Ordering Information

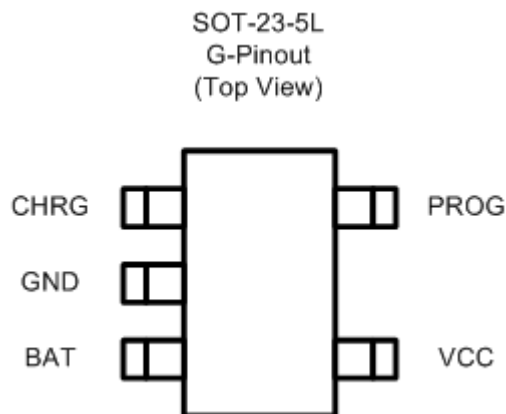

Features

- Programmable Charge Current Up to 800mA.
- No MOSFET, Sense Resistor or Blocking Diode Required.
- Constant-Current/Constant-Voltage Operation with Thermal Protection to Maximize Charge Rate without Risk of Overheating.
- Charges Single Cell Li-Ion Batteries Directly from USB Port.
- Preset 4.2V Charge Voltage with $\pm 1\%$ Accuracy.
- 25uA Supply Current in Shutdown.
- 2.9V Trickle Charge Threshold
- Available Without Trickle Charge.
- Soft-Start Limits Inrush Current.
- Available in 5-Lead SOT-23 Package.

Application

- Cellular Telephones, PDA's, MP3 Players.
- Charging Docks and Cradles
- Bluetooth Applications

Typical Applications

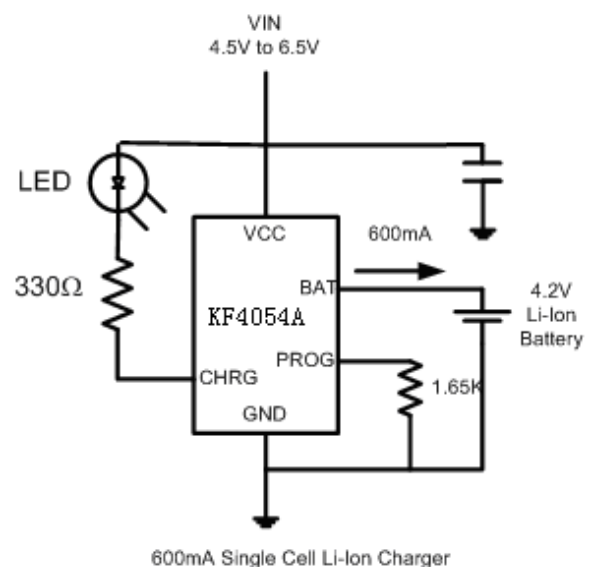

Absolute Maximum Rating (1)

Parameter	Symbol	Value	Units
Input Supply Voltage	V_{CC}	10	V
PROG Voltage	V_{PROG}	$V_{CC}+0.3$	V
BAT Voltage	V_{BAT}	7	V
CHRG Voltage	V_{CHRG}	10	V
BAT Short-Circuit Duration		Continuous	
BAT Pin Current	I_{BAT}	800	mA
PROG Pin Current	I_{PROG}	800	A
Maximum Junction Temperature	T_J	125	°C
Storage Temperature	T_S	-65 to +125	°C
Lead Temperature (Soldering, 10 sec)		300	°C

Operating Rating (2)

Parameter	Symbol	Value	Units
Supply Input Voltage	V_{IN}	-0.3 to +10	V
Junction Temperature	T_J	-40 to +85	°C

Electrical Characteristics

$V_{IN} = 5V$; $T_J = 25^\circ C$; unless otherwise specified.

Symbol	Parameter	Conditions	Min	Typ	Max	Unit
V_{CC}	Input Supply Voltage		4.25		6	V
I_{CC}	Input Supply Current	Charge Mode ⁽³⁾ , $R_{PROG} = 10k$		190		μA
		Standby Mode (Charge Terminated)		85		μA
		Shutdown Mode (R_{PROG} Not Connected, $V_{CC} < V_{BAT}$, or $V_{CC} < V_{UV}$)		12		μA
V_{FLOAT}	Regulated Output (Float) Voltage	$0^\circ C \leq T_J \leq 85^\circ C$, $I_{BAT} = 40mA$		4.2		V
I_{BAT}	BAT Pin Current	$R_{PROG} = 10k$, Current Mode		110		mA
		$R_{PROG} = 2k$, Current Mode		500		mA
		Standby Mode, $V_{BAT} = 4.2V$		4		μA
		Shutdown Mode (R_{PROG} Not Connected)		± 1		μA
		Sleep Mode, $V_{CC} = 0V$		± 1		μA
I_{TRIKL}	Trickle Charge current	$V_{BAT} < V_{TRIKL}$, $R_{PROG} = 10k$		12		mA
V_{TRIKL}	Trickle Charge Threshold Voltage	$R_{PROG} = 10k$, V_{BAT} Rising		2.9		V

**Electrical Characteristics (Continued)** $V_{IN} = 5V$; $T_J = 25^{\circ}C$; unless otherwise specified

Symbol	Parameter	Conditions	Min	Typ	Max	Unit
V_{UV}	V_{CC} Undervoltage Lockout Threshold	From V_{CC} Low to High		3.4		V
V_{UVHYS}	V_{CC} Undervoltage Lockout Hysteresis			170		mV
V_{MSD}	Manual Shutdown Threshold Voltage	PROG Pin Rising		1.25		V
		PROG Pin Falling		1.2		V
V_{ASD}	$V_{CC} - V_{BAT}$ Lockout Threshold Voltage	V_{CC} from Low to High		100		mV
		V_{CC} from High to Low		30		mV
I_{TERM}	C/10 Termination Current Threshold	$R_{PROG} = 10k^{(4)}$		0.1		mA
		$R_{PROG} = 2k$		0.1		mA
V_{PROG}	PROG Pin Voltage	$R_{PROG} = 10k$, Current Mode		1.03		V
I_{CHRG}	CHRG Pin Weak Pull-Down Current	$V_{CHRG} = 5V$		20		μA
V_{CHRG}	CHRG Pin Output Low Voltage	$I_{CHRG} = 5mA$		0.35		V
ΔV_{RECHRG}	Recharge Battery Threshold Voltage	$V_{FLOAT} - V_{RECHRG}$		100		mV
T_{LIM}	Junction Temperature in Constant Temperature Mode			120		$^{\circ}C$
t_{SS}	Soft-Start Time	$I_{BAT} = 0$ to $1000V/R_{PROG}$		100		μs
$t_{RECHARGE}$	Recharge Comparator Filter Time	V_{BAT} High to Low		2		ms
t_{TERM}	Termination Comparator Filter Time	I_{BAT} Falling Below $I_{CHG}/10$		1000		μs
I_{PROG}	PROG Pin Pull-Up Current			1		μA

Note 1: Exceeding the absolute maximum rating may damage the device.

Note 2: The device is not guaranteed to function outside its operating rating.

Note 3: Supply current includes PROG pin current (approximately $100\mu A$) but does not include any current delivered to the battery through the BAT pin (approximately 100mA).

Note 4: I_{TERM} is expressed as a fraction of measured full charge current with indicated PROG resistor.

Application Hints

Stability Considerations

The constant-voltage mode feedback loop is stable without an output capacitor provided a battery is connected to the charger output. With no battery present, an output capacitor is recommended to reduce ripple voltage. When using high value, low ESR ceramic capacitors, it is recommended to add a 1Ω resistor in series with the capacitor. No series resistor is needed if tantalum capacitors are used.

In constant-current mode, the PROG pin is in the feedback loop, not the battery. The constant-current mode stability is affected by the impedance at the PROG pin. With no additional capacitance on the PROG pin, the charger is stable with program resistor values as high as 20k. However, additional capacitance on this node reduces the maximum allowed program resistor. The pole frequency at the PROG pin should be kept above 100kHz.

V_{CC} Bypass Capacitor

Many types of capacitors can be used for input bypassing, however, caution must be exercised when using multilayer ceramic capacitors. Because of the self-resonant and high Q characteristics of some types of ceramic capacitors, high voltage transients can be generated under some start-up conditions, such as connecting the charger input to a live power source. Adding a 1.5Ω resistor in series with a ceramic capacitor

will minimize start-up voltage transients.

Power Dissipation

The conditions that cause the KF4054 to reduce charge current through thermal feedback can be approximated by considering the power dissipated in the IC. Nearly all of this power dissipation is generated by the internal MOSFET—this is calculated to be approximately:

$$P_D = (V_{CC} - V_{BAT}) \cdot I_{BAT}$$

The approximate ambient temperature at which the thermal feedback begins to protect the IC is:

$$T_A = 120^\circ\text{C} - P_D \theta_{JA}$$
$$T_A = 120^\circ\text{C} - (V_{CC} - V_{RAT}) \cdot I_{RAT} \cdot \theta_{IA}$$

Thermal Considerations

Because of the small size of the ThinSOT package, it is very important to use a good thermal PC board layout to maximize the available charge current. The thermal path for the heat generated by the IC is from the die to the copper lead frame, through the package leads, (especially the ground lead) to the PC board copper. The PC board copper is the heat sink. The footprint copper pads should be as wide as possible and expand out to larger copper areas to spread and dissipate the heat to the surrounding ambient. Other heat sources on the board, not related to the charger, must also be considered when designing a PC board layout because they will affect overall temperature rise and the maximum charge current.

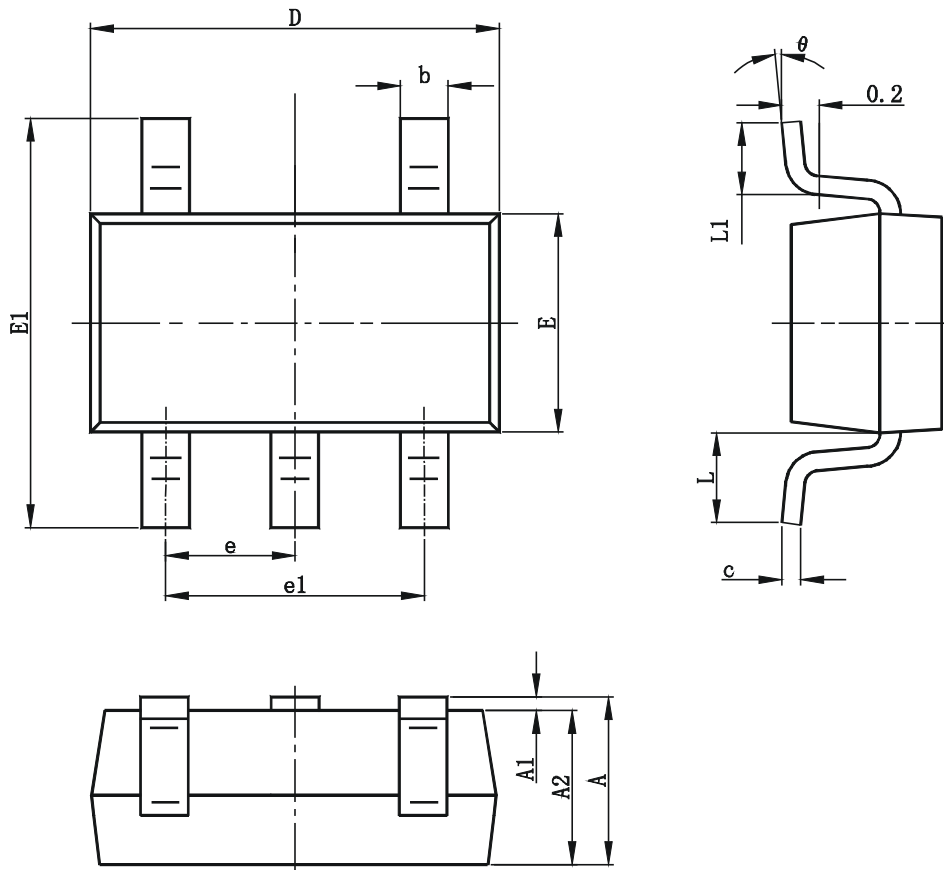
Package Information
SOT-23-5L PACKAGE OUTLINE DIMENSIONS

Symbol	Dimensions In Millimeter		Dimensions In Inches	
	Min	Max	Min	Max
A	1.050	1.250	0.041	0.049
A1	0.000	0.100	0.000	0.004
A2	1.050	1.150	0.041	0.045
b	0.300	0.400	0.012	0.016
c	0.100	0.200	0.004	0.008
D	2.820	3.020	0.111	0.119
E	1.500	1.700	0.059	0.067
E1	2.650	2.950	0.104	0.116
e	0.950TYP		0.037TYP	
e1	1.800	2.000	0.071	0.079
L	0.700REF		0.028REF	
L1	0.300	0.600	0.012	0.024
?	0	8	0	8