

**2A Constant Current Buck Converter
for Powering LEDs**

GENERAL DESCRIPTION

The FP7101A is a current-mode buck regulator with a built in internal 2A power MOSFET. It provides a simple, high efficiency solution for driving high power LEDs. With a 0.2V reference voltage feedback control to minimize power dissipation, an external resistor sets the current as needed for driving various types of LEDs. Current mode operation provides fast transient response and eases loop stabilization. The FP7101A requires a minimum number of readily available external components to complete a 2A buck regulator solution. The device includes cycle-by-cycle current limiting and thermal shutdown protection. Additional features include user accessible EN/DIM pin for enabling and PWM dimming of LEDs.

FEATURES

- 2A Output Current
- 0.22Ω Internal Power MOSFET Switch
- Stable with Low ESR Output Ceramic Capacitors
- Up to 90% Efficiency
- 25μA Shutdown Mode Current
- Fixed 380KHz frequency
- Thermal Shutdown
- Cycle-by-Cycle Over Current Protection
- Wide 4.75 to 23V operating Input Range
- Output Adjustable From 0.2 to 16V
- Available SOP8 & PDIP8 Package
- Under Voltage Lockout

APPLICATIONS

- LED Driver
- Constant Current Source
- Industrial Lighting
- LED Flashlights

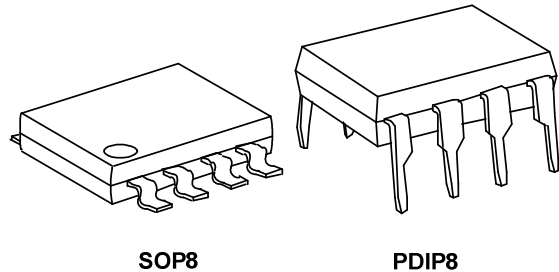

TYPICAL APPLICATION CIRCUIT

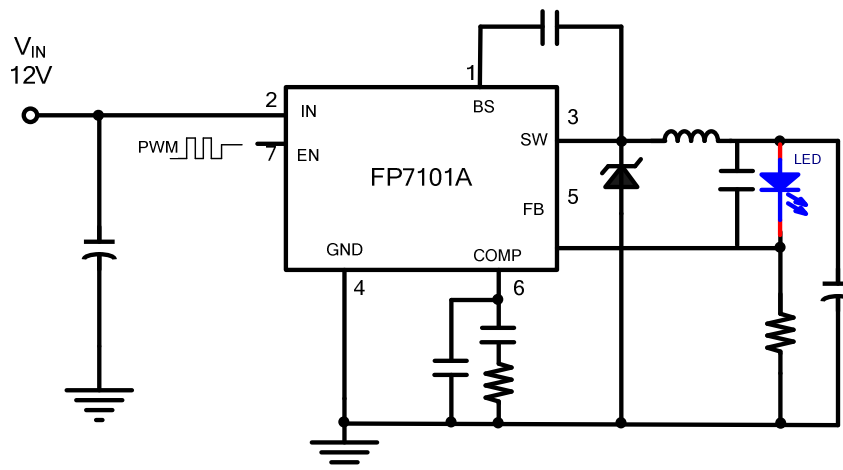

FUNCTIONAL BLOCK DIAGRAM

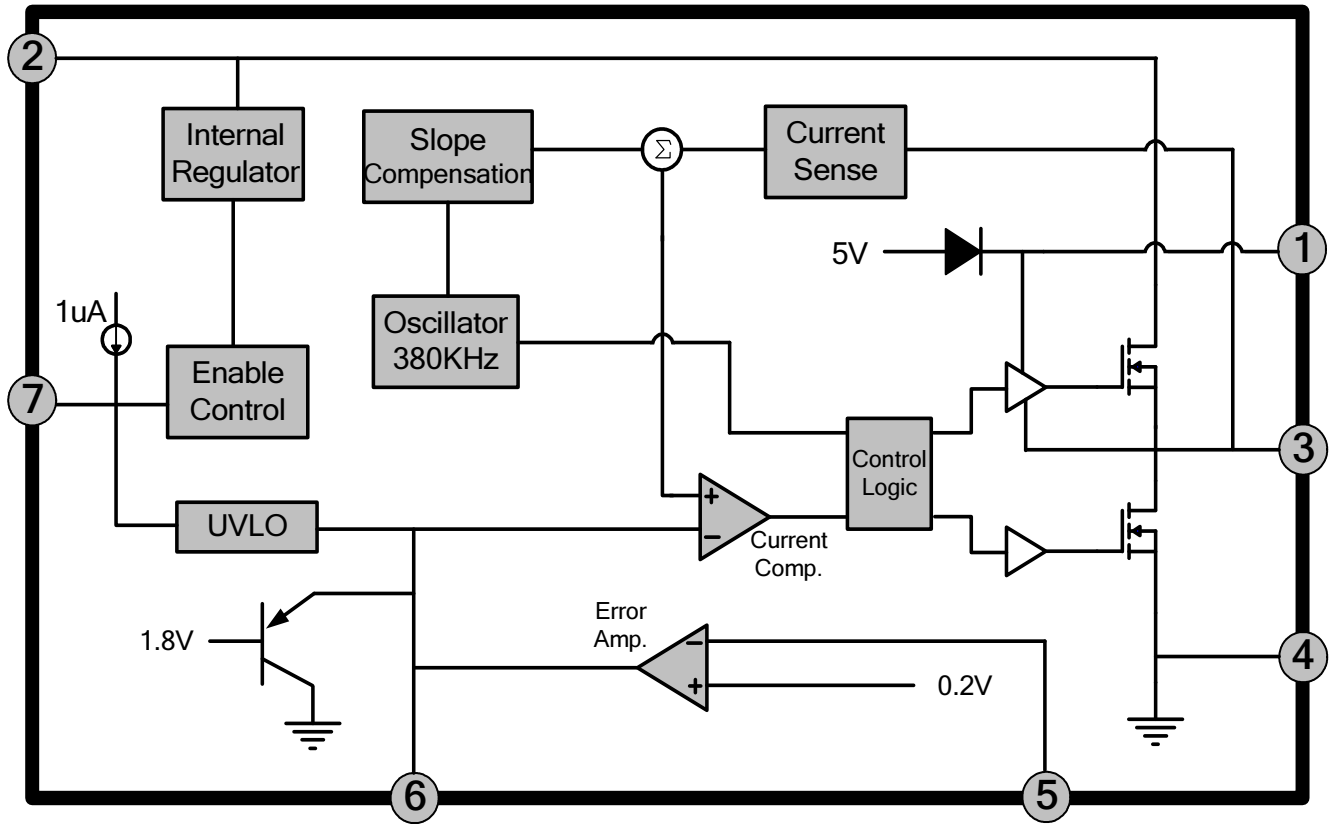

MARK VIEW

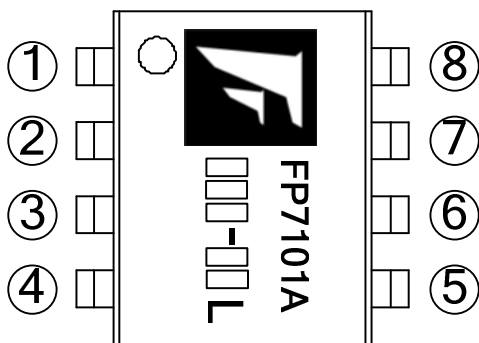

PIN DESCRIPTION

Name	No.	I/O	Description
BS	1	O	Bootstrap Pin
IN	2	P	Supply Voltage
SW	3	O	Switch Pin
GND	4	P	Ground
FB	5	I	Feedback Pin
COMP	6	O	Compensation Pin
EN/DIM	7	I	Enable/UVLO
NC	8	-	NC

ORDER INFORMATION

Part Number	Operating Temperature	Package	Description
FP7101ADR-G1	-40°C ~ +85°C	SOP8	Tape & Reel
FP7101AD-G1	-40°C ~ +85°C	SOP8	Tube
FP7101AP-G1	-40°C ~ +85°C	PDIP8	Tube

IC DATE CODE DISTINGUISH

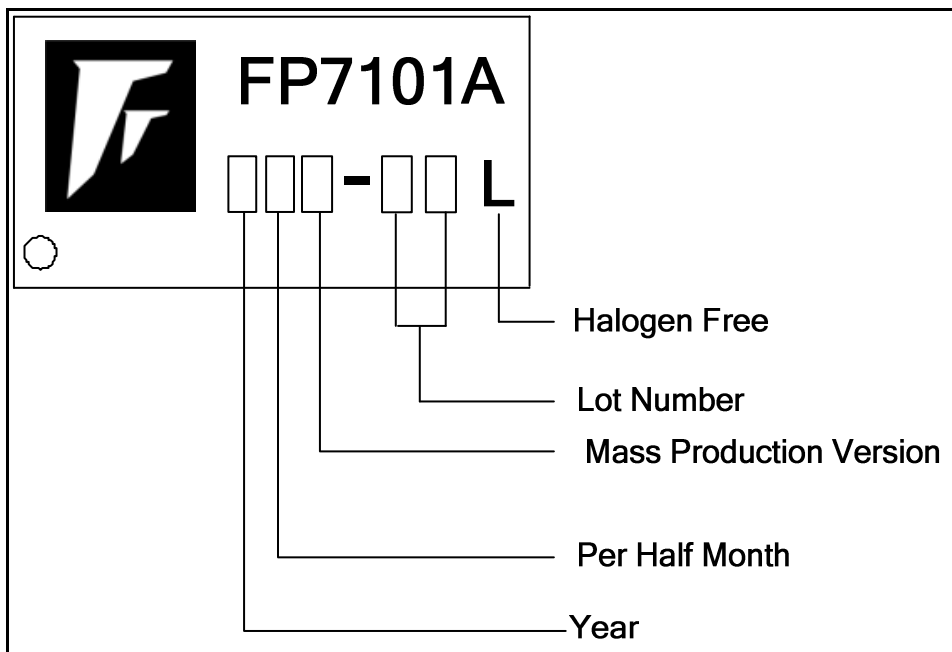

For example:

- 1 – Year 2001
- 2 – Year 2002
- 3 – Year 2003 ----- And so on

Lot Number is the last two numbers

For example:

A3311C62
 ↳ Lot Number

ABSOLUTE MAXIMUM RATINGS

Supply Voltage (V_{IN})	-0.3V to 24V
Switch Voltage (V_{SW})	-1V to $V_{IN} + 0.3V$
Bootstrap Voltage (V_{BS})	$V_{SW} - 0.3V$ to $V_{SW} + 6V$
All Other Pins	-0.3V to 6V
Junction Temperature	150°C
Storage Temperature	-65°C to 150°C
Allowable Power Dissipation ($T_a \leq +25^\circ C$)	
SOP8	570mW
PDIP	800mW
Thermal Resistance(Junction to Ambient, θ_{JA})	
SOP8	175°C/W
PDIP8	125°C/W
Lead Temperature (soldering, 10 sec)	
SOP8	+260°C
PDIP8	+270°C

Recommended Operating Conditions

Supply Voltage (V_{IN})	4.75~23V
Operating temperature	-40°C ~ +85°C

DC ELECTRICAL CHARACTERISTICS ($T_a = 25^\circ\text{C}$, $V_{IN} = 12\text{V}$, unless otherwise noted)

PARAMETER	SYMBOL	TEST CONDITIONS	MIN	TYP	MAX	UNIT
Standby Current	I_{SB}	$V_{EN} \geq 3\text{V}, V_{FB} \geq 0.5\text{V}$		1.0	1.5	mA
Shutdown Supply Current	I_{ST}	$V_{EN} = 0$		25	50	μA
Feedback Voltage	V_{FB}	$V_{IN} = 12\text{V}, V_{COMP} < 2\text{V}$		0.2		V
High Side Switch ON Resistance	R_{ON-HS}			0.22		Ω
Low Side Switch ON Resistance	R_{ON-LS}			10		Ω
High Side Switch Leakage Current	I_{IL}	$V_{EN} = 0, V_{SW} = 0\text{V}$		0.1	10	μA
Current Limit	I_{CL}		2.8	3.4		A
Oscillation Frequency	f_{OSC}			380		KHz
Maximum Duty Cycle	D_{MAX}	$V_{FB} = 0.195\text{V}$		90		%
Minimum Duty Cycle	D_{MIN}	$V_{FB} = 0.3\text{V}$			0	%
Under Voltage Lockout Threshold	V_{UVLO}	V_{EN} Rising	2.0	2.5	3.0	V
Under Voltage Lockout Threshold Hysteresis	V_{HYS}			200		mV
EN Threshold Voltage	V_{EN}	$I_{CC} > 100\mu\text{A}$	0.7	1.0	1.3	V
Enable Pull Up Current	I_{EN}	$V_{EN} = 0\text{V}$		1.0		μA
Thermal Shutdown	T_{TS}			140		$^\circ\text{C}$

FUNCTION DESCRIPTION

The FP7101A is a current-mode buck regulator. It regulates input voltages from 4.75V to 23V down to an output voltage as low as 0.2V, and is able to supply up to 2A of load current.

The FP7101A uses current-mode control to regulate the output voltage. The output voltage is measured at FB through a resistive voltage divider and amplified through the internal error amplifier. The output current of the transconductance error amplifier is presented at COMP where a network compensates the regulation control system. The voltage at COMP is compared to the switch current measured internally to control the output voltage.

The converter uses an internal n-channel MOSFET switch to step-down the input voltage to the regulated output voltage. Since the MOSFET requires a gate voltage greater than the input voltage, a boost capacitor connected between SW and BS drives the gate.

The capacitor is internally charged while the switch is off. An internal 10Ω switch from SW to GND is used to insure that SW is pulled to GND when the switch is off to fully charge the BS capacitor.

SETTING THE LED CURRENT

FP7101A is a constant current buck regulator. The LEDs are connected between V_{OUT} and FB pin as shown in the Typical Application Circuit. The FB pin is at 0.2V in regulation and therefore the LED current I_F is set by V_{FB} and the resistor R_2 from FB to ground by the following equation:

$$I_F = V_{FB} / R_2$$

I_F should not exceed the 2A current capability of FP7101A and therefore R_2 minimum must be approximately 0.1Ω.

OUTPUT VOLTAGE

The output voltage is primarily determined by the number of LEDs(n) connected from V_{OUT} to FB pin and therefore V_{OUT} can be written as:

$$V_{OUT} = ((n \times V_F) + V_{FB})$$

where V_F is the forward voltage of one LED at the set LED current level (see LED manufacturer datasheet for forward characteristics curve).

LED PWM DIMMING

The LED brightness can be controlled by applying a periodic pulse signal to the EN/DIM pin and varying its frequency and or duty cycle. This PWM dimming method controls the average light output by pulsing the LED current between the set value and zero. A logic high level at the EN/DIM pin turns on the LED current whereas a logic low level turns off the LED current

SHUTDOWN MODE

Drive enable Pin to ground to shut down the FP7101A. Shutdown forces the internal power MOSFET off, turns off all internal circuitry, and reduces the V_{IN} supply current to $25\ \mu\text{A}$ (typ). The enable Pin rising threshold is 1.0V (typ). Before any operation begins, the voltage at Enable Pin must exceed 1.0V (typ).

BOOST HIGH-SIDE GATE DRIVE(BST)

Since the MOSFET requires a gate voltage greater than the input voltage, connect a flying bootstrap capacitor between SW and BS to provide the gate-drive voltage to the high-side n-channel MOSFET switch. The capacitor is alternately charged from the internally regulator.

On startup, an internal low-side switch connects SW to ground and charges the BST capacitor to internally regulator voltage. Once the BST capacitor is charged, the internal low-side switch is turned off and the BST capacitor voltage provides the necessary enhancement voltage to turn on the high-side switch.

THERMAL SHUTDOWN PROTECTION

The FP7101A features integrated thermal shutdown protection. Thermal shutdown protection limits allowable power dissipation(P_D) in the device, and protects the device in the event of a fault condition. When the IC junction temperature exceeds $+140^\circ\text{C}$, an internal thermal sensor signals the shutdown logic, turning off the internal power MOSFET and allowing the IC to cool down. The thermal sensor turns the internal power MOSFET back on after the IC junction temperature cools down to $+110^\circ\text{C}$, resulting in a pulsed output under continuous thermal overload conditions.

APPLICATIONS INFORMATION

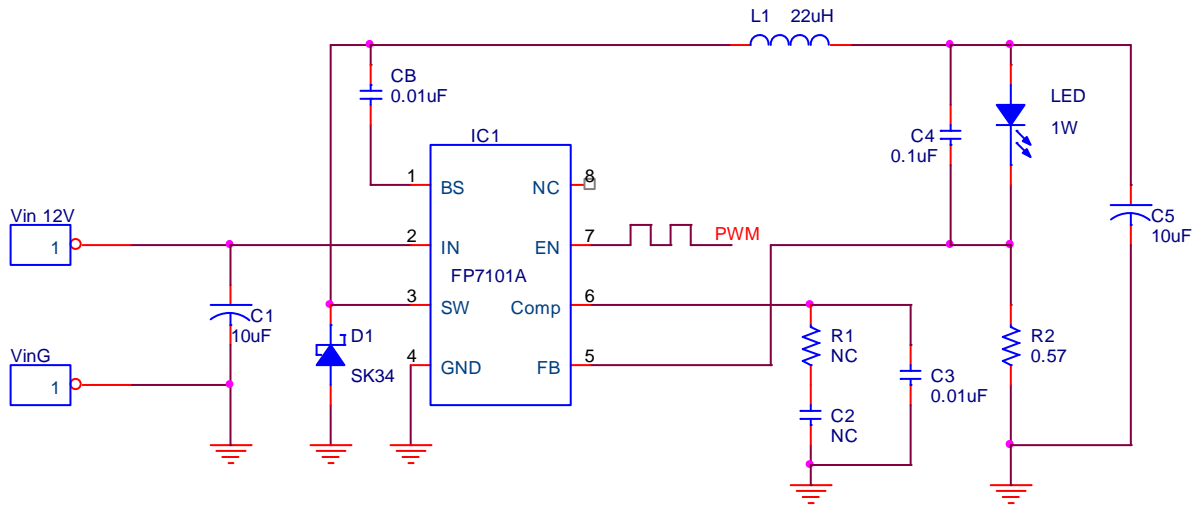

Figure 1: 1W * 1 LED for DC Input

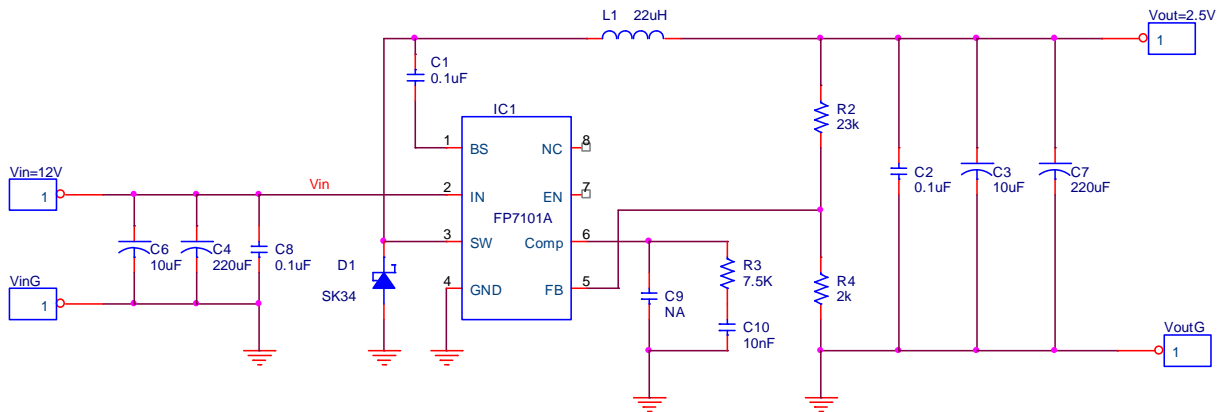
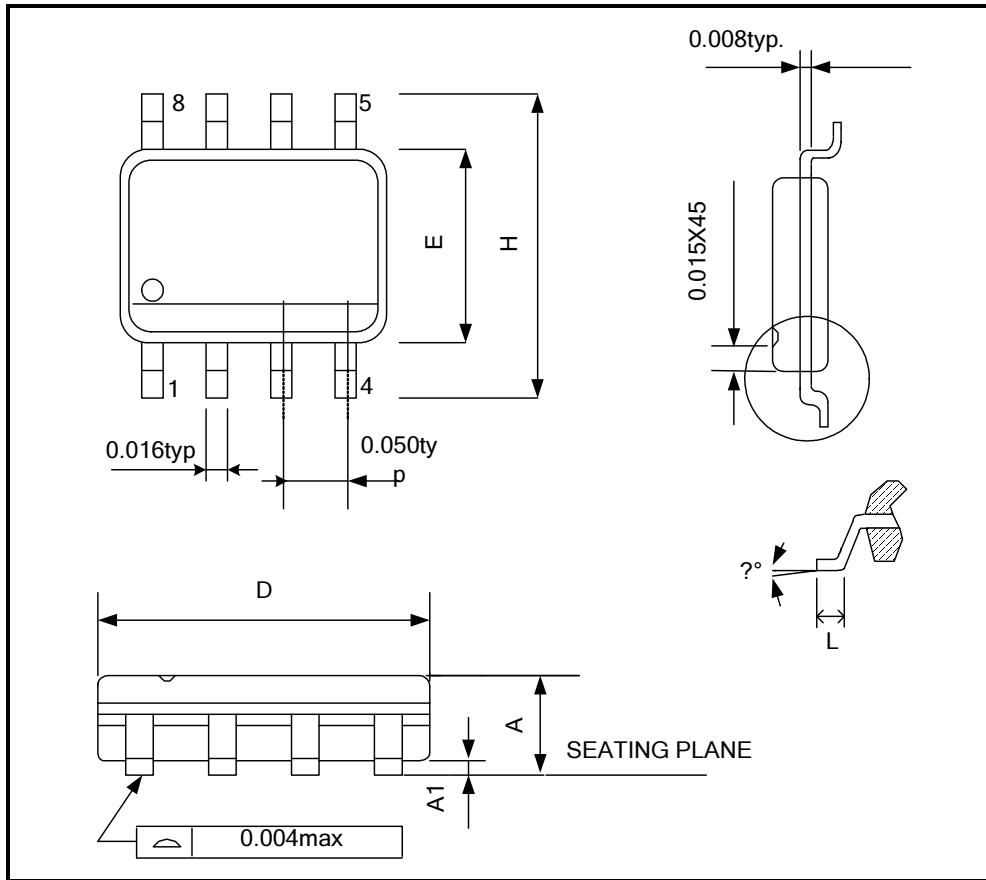

Figure 2: DC to DC Voltage Regulator

PACKAGE OUTLINE

SOP8



SYMBOLS	MIN	MAX
A	0.053	0.069
A1	0.004	0.010
A2	-	0.059
D	0.189	0.196
E	0.150	0.157
H	0.228	0.244
L	0.016	0.050
θ°	0	8

UNIT:INCH

NOTE:

1. JEDEC OUTLINE:MS-012 AA ◦
2. DIMENSIONS "D" DOES NOT INCLUDE MOLD FLASH,PROTRUSIONS OR GATE BURRS.MOLD FLASH,PROTRUSIONS AND GATE BURRS SHALL NOT EXCEED .15mm (.006in) PER SIDE ◦
3. DIMENSIONS "E" DOES NOT INCLUDE INTER-LEAD FLASH,OR PROTRUSIONS INTER-LEAD FLASH AND PROTRUSIONS SHALL NOT EXCEED .25mm (.010in) PER SIDE ◦

PDIP 8

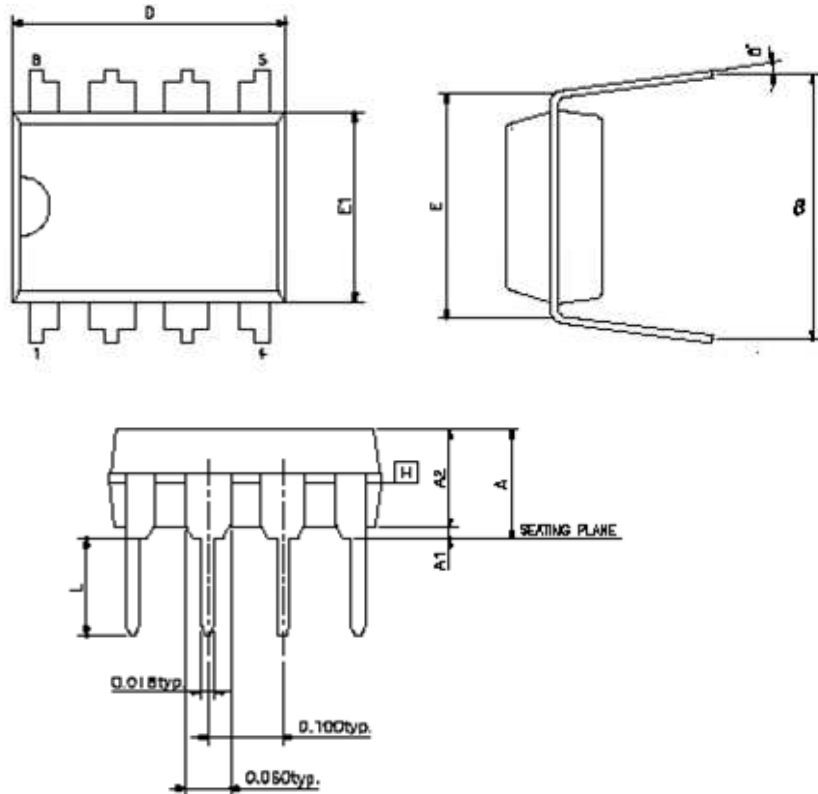

UNIT:INCH

SYMBOLS	MIN	NOR	MAX
A	-	-	0.210
A1	0.015	-	-
A2	0.125	0.130	0.135
D	0.355	0.365	0.400
E	0.300BSC.		
E1	0.245	0.250	0.255
L	0.115	0.130	0.150
e_{θ}	0.335	0.355	0.375
θ°	0	7	15

Note:

1. JEDEC OUTLINE:MS-001 BA.
2. "D" 、"E1" DIMENSIONS DO NOT INCLUDE MOLD FLASH OR PROTRUSIONS SHALL NOT EXCEED .010 INCH.
3. e_{θ} IS MEASURED AT THE LEAD TIPS WITH THE LEADS UNCONSTRAINED.
4. POINTED OR ROUNDED LEAD TIPS ARE PREFERRED TO EASE INSERTION.
5. DISTANCE BETWEEN LEADS INCLUDING DAM BAR PROTRUSIONS TO BE .005 INCH MINIMUM.
6. DATUM PLANE H COINCIDENT WITH THE BOTTOM OF LEAD, WHERE LEAD EXITS BODY.

PACKING SPECIFICATIONS

BOX & CARTON DIMENSION

PDIP8

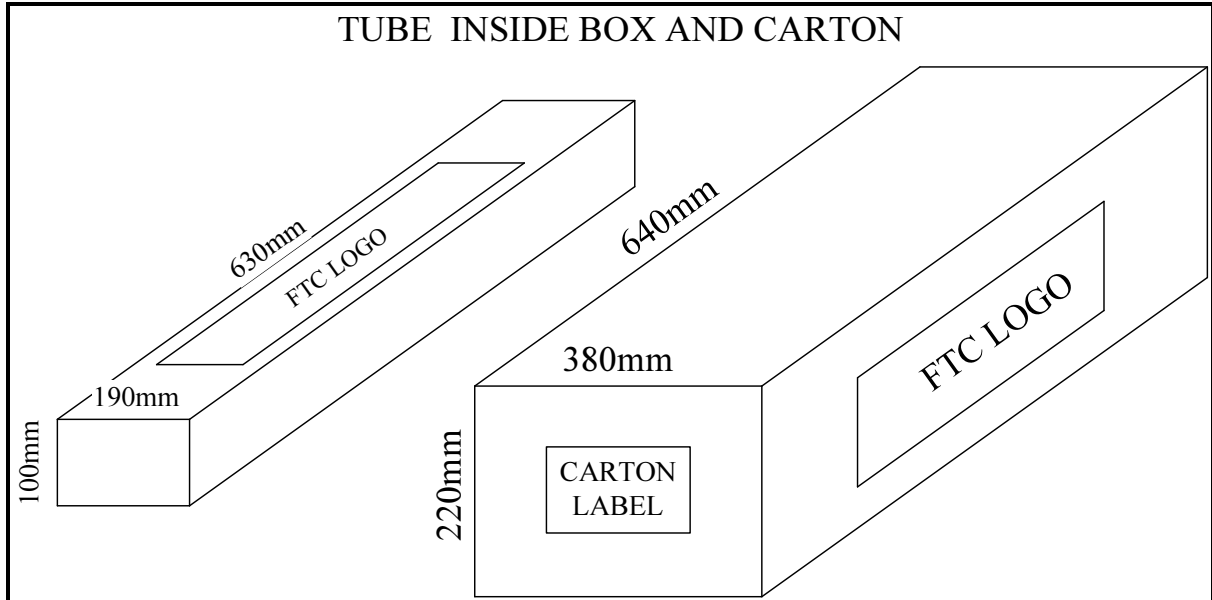

SOP8

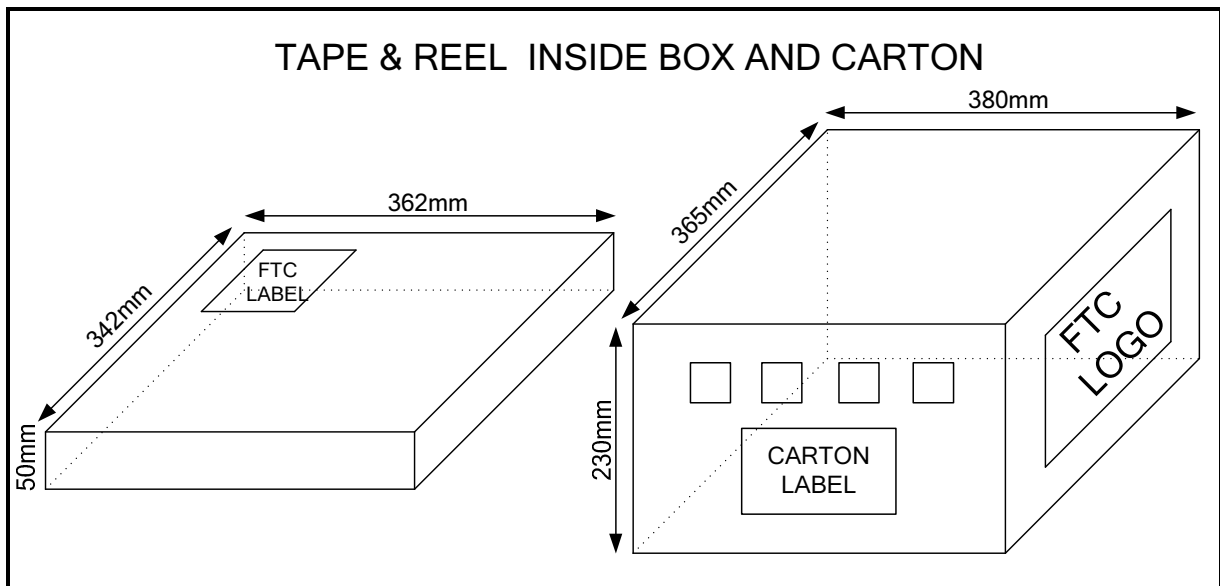

PACKING QUANTITY SPECIFICATIONS

SOP8	PDIP8
2500 EA / REEL	60 EA/TUBE
1 REELS / INSIDE BOX	60 TUBES / INSIDE BOX
4 INSIDE BOXES / CARTON	4 INSIDE BOXES / CARTON

CARRIER TAPE AND REEL DIMENSIONS

SOP8

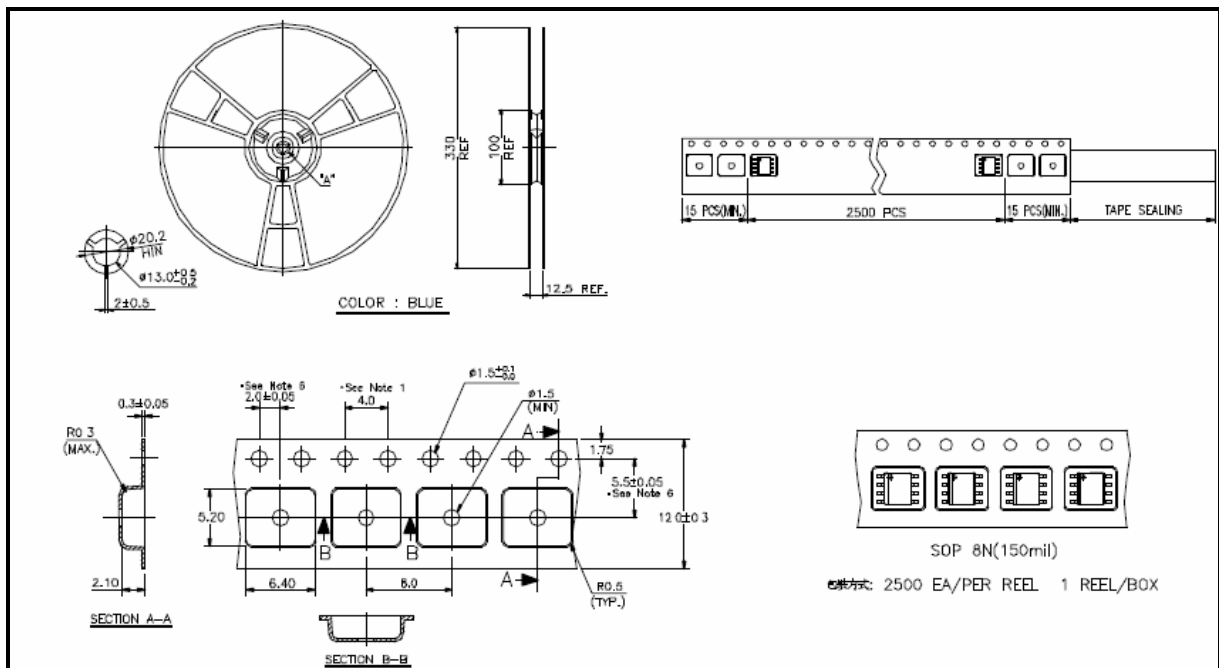

Note:

1. 10 SPROCKET HOLE PITCH CUMULATIVE TOLERANCE ± 0.2 mm.
2. COMBER NOT TO EXCEED 1mm IN 100mm.
3. MATERIAL : ANTI-STATIC BLOCK ADVANTEK POLYSTYRENE.
4. A₀ AND B₀ MEASURED ON A PLANE 0.3mm ABOVE THE BOTTOM OF THE POCKET.
5. K₀ MEASURED FROM A PLANE AN THE INSIDE BOTTOM OF THE POCKET TO THE TOP SURFACE OF THE CARRIER.
6. POCKET POSITION RELATIVE TO SPROCKET HOLE MEASURED AS TRUE POSITION OF POCKET , NOT POCKET HOLE.

SOLDER PROFILE

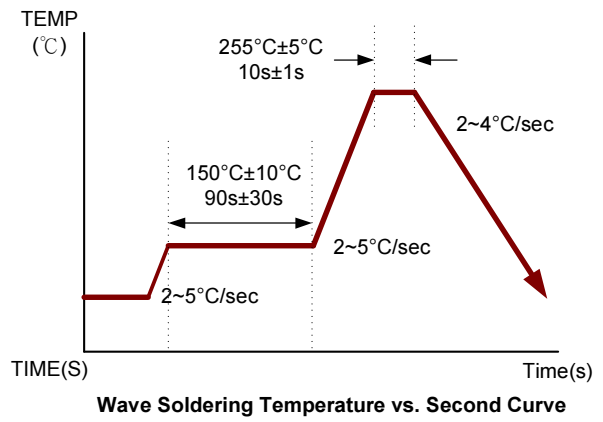
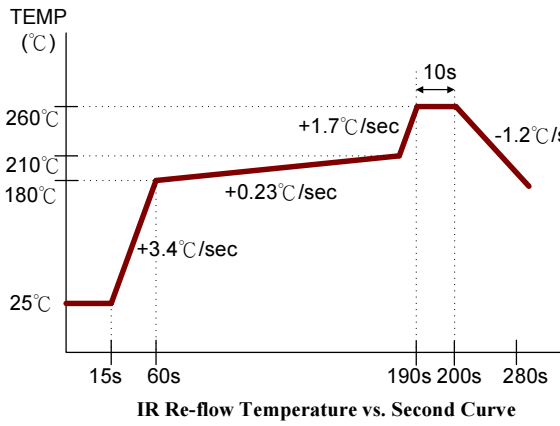

Note:

1. Suggest IR Reflow Soldering Profile Condition.