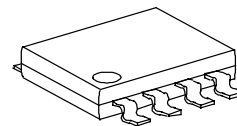

Low-Noise Step-Up Current Mode PWM IC**GENERAL DESCRIPTION**

The **FP6290** is a boost converter of current mode , PWM circuitry with a built-in 0.2 power MOSFET provides a highly efficient regulator. Selectable high switching frequency allows easy filtering, faster loop performance in a low noise output. The non-inverting input of error amplifier connects to a 1.24V precision reference voltage. Soft-Start is programmed with an external capacitor, which sets the input current ramp rate. Current mode control and external compensation network make it easy and flexible to stabilize the system. The **FP6290** is available in the MSOP-8L package, using of low ESR capacitors and reduced PCB space for the step-up application fields.

FEATURES

- Precision feedback reference voltage: 1.24V
- Current Limit Protection
- Internal fixed PWM frequency
- Pin control frequency: 640KHz/1.2MHz
- External Programmable Soft-Start function (SS)
- Internal 0.2 , 1.6A, 14V Power MOSFET
- Shutdown Current : 0.1uA
- Adjustable Output from VCC to 12V
- Package: MSOP8

**MSOP8****TYPICAL APPLICATION**

- LCD Display
- Digital Camera
- Hand-Held Device
- Portable product

FUNCTIONAL BLOCK DIAGRAM

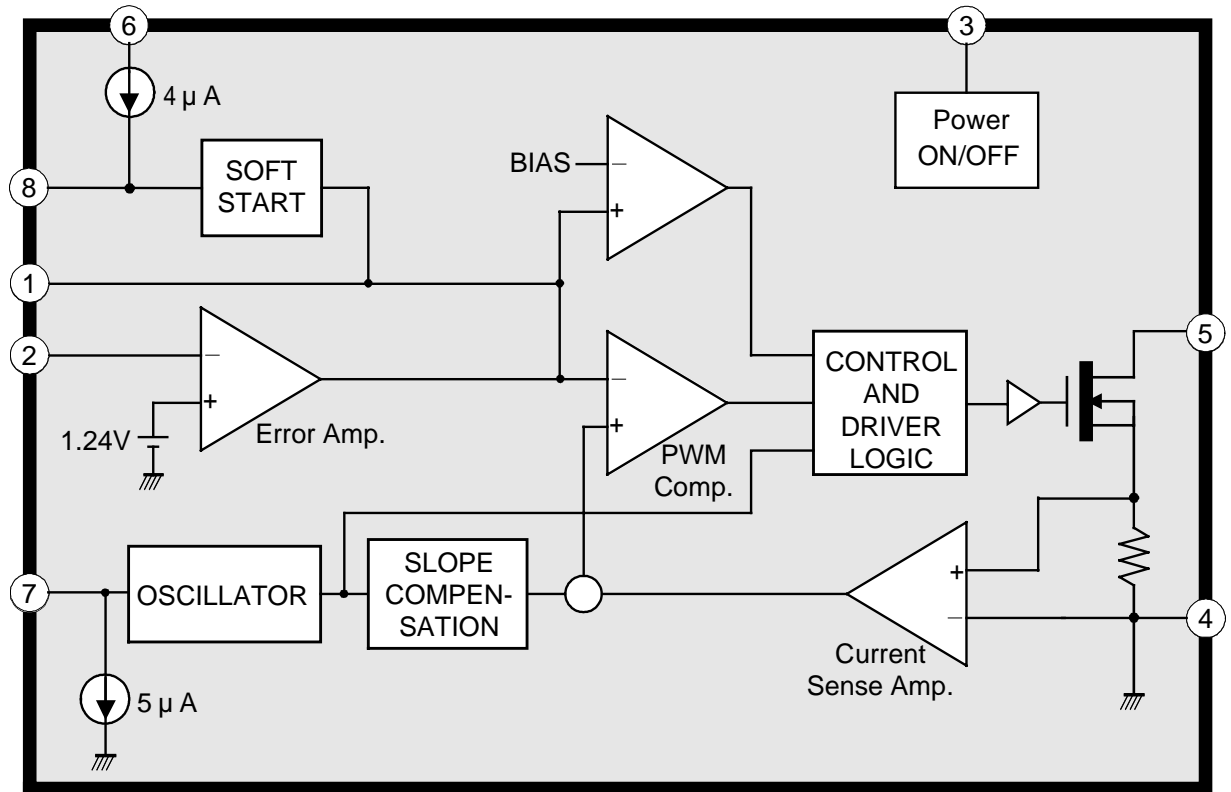

MARK VIEW

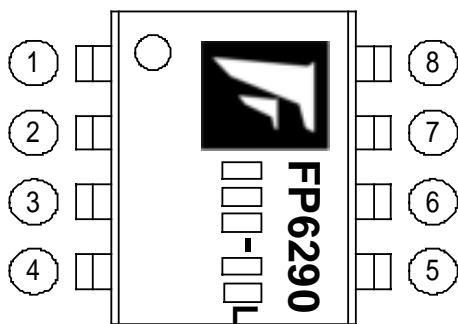

PIN DESCRIPTION

NAME	NO.	STATUS	DESCRIPTION
COMP	1	O	Error Amplifier Compensation Output
FB	2	I	Error Amplifier Inverting Input
EN	3	I	Enable Control
GND	4	P	IC Ground
LX	5	O	Switch Output
VCC	6	P	IC Power Supply
FREQ	7	O	Frequency Selection
SS	8	I	Soft-start Control

ORDER INFORMATION

Part Number	Operating Temperature	Package	Description
FP6290T-LF	-40°C ~ +85°C	MSOP8	Tube
FP6290TR-LF	-40°C ~ +85°C	MSOP8	Tape & Reel

IC DATE CODE DISTINGUISH

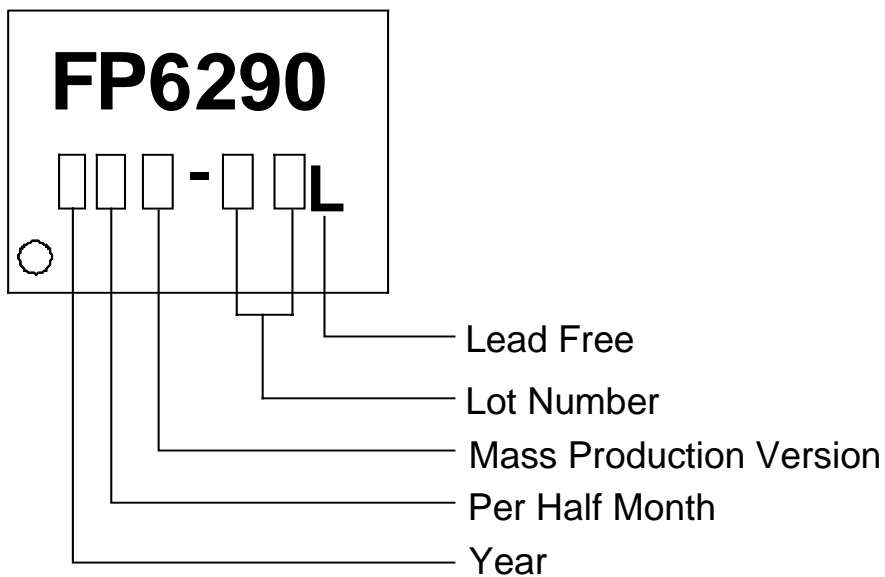

FOR EXAMPLE:

January A (Front Half Month), B (Last Half Month)
 February C, D
 March E, F -----And so on

Lot Number is the last two numbers

For Example:

A3311C62
 ↳ Lot Number

ABSOLUTE MAXIMUM RATINGS

Supply Voltage (VCC) -----	+6.0V
RMS LX Current -----	1.2A
LX to GND -----	-0.3V +14V
SS,COMP to GND -----	-0.3V VCC+0.3V
EN,FREQ,FB to GND -----	-0.3V VCC
Allowable dissipation	
MSOP8 Ta +70 -----	330mW
Operating temperature-----	-40 +85
Storage temperature-----	-55 +125
MSOP8 Lead Temperature (soldering, 10 sec) -----	+260

Recommend: IR Reflow

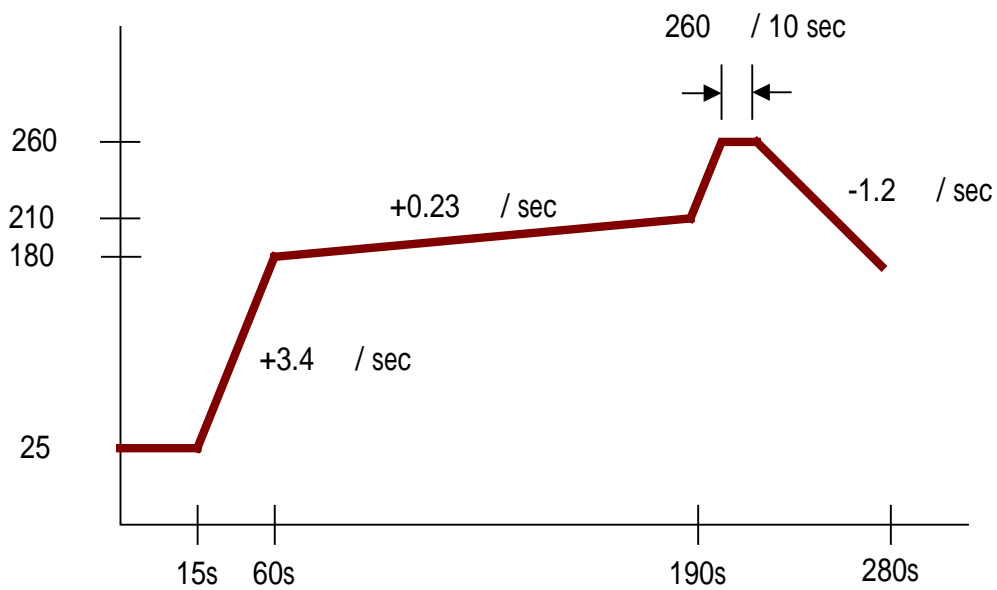

IR Re-flow Soldering Curve

DC ELECTRICAL CHARACTERISTICS

Electrical characteristics over recommended operating free-air temperature range, VCC=3V, FREQ=GND (unless otherwise noted)

Reference section

PARAMETER	SYMBOL	TEST CONDITIONS	MIN	TYP	MAX	UNIT
Output voltage	V_{REF}	COMP connected to FB	1.222	1.240	1.258	V
Line regulation	V_{REF}/V_{REF}	VCC=2.6V 5.5V		0.05		% / V
Output voltage change with Temperature		$T_A=-40$ to 25		1		%
		$T_A=25$ to 85		1		

Under voltage lockout section

PARAMETER	SYMBOL	TEST CONDITIONS	MIN	TYP	MAX	UNIT
Upper threshold voltage(Vcc)	V_{UPPER}	$T_A=25$		2.38	2.53	V
Lower threshold voltage(Vcc)	V_{LOW}			2.33	2.48	V
Hysteresis (Vcc)	V_{HYS}			50		mV

Soft-start section

PARAMETER	SYMBOL	TEST CONDITIONS	MIN	TYP	MAX	UNIT
Reset switch Resistance	R_{SS}				100	
Input source current	I_{SS}	$V_{SS}=1.2V$	1.5	4.0	7.0	μA

Oscillator section

PARAMETER	SYMBOL	TEST CONDITIONS	MIN	TYP	MAX	UNIT
Frequency	f	FREQ=GND	540	640	740	KHz
		FREQ=VCC	1.00	1.24	1.50	MHz
Frequency change with voltage	f/ V	VCC=2.6V to 5.5V		2		% / V
Frequency change with Temperature	f/ T	$T_A=-40$ to 85		10		%
Maximum duty cycle	T_{DUTY}	FREQ=GND	79	85		%
		FREQ=VCC		84		%

Error –amplifier section

PARAMETER	SYMBOL	TEST CONDITIONS	MIN	TYP	MAX	UNIT
FB Input bias current	I_{BIAS}	$V_{FB}=1.24V$			40	nA
Transconductance	gm	$I=5 \mu A$	70	140	240	$\mu A/V$
Voltage Gain	A_v			700		V/V

Output section

PARAMETER	SYMBOL	TEST CONDITIONS	MIN	TYP	MAX	UNIT
NMOS Current Limit	I_{LIM}	$V_{FB}=1V, Duty Cycle=65\%$	1.2	1.6	2.3	A
NMOS On resistance	$R_{DS(ON)}$	$I_{LX}=1.2A$		0.2	0.5	
Output leakage current	I_{LXOFF}	$V_{LX}=12V$		0.01	20	μA
Current-Sense Trans-resistance	R_{CS}			0.56		V/A

DC ELECTRICAL CHARACTERISTICS (Cont.)

Control Input section

PARAMETER	SYMBOL	TEST CONDITIONS	MIN	TYP	MAX	UNIT
Input High Voltage	V_{IH}	EN,FREQ; VCC=2.6V~5.5V	$0.7 \times V_{CC}$			V
Input Low Voltage	V_{IL}	EN,FREQ; VCC=5.5V~2.6V			$0.3 \times V_{CC}$	V
Hysteresis		EN,FREQ		$0.1 \times V_{CC}$		V
FREQ Pull-Down Current	I_{FREQ}		1.8	5	9	μA
EN Input Current	I_{EN}			1		nA

Total device

PARAMETER	SYMBOL	TEST CONDITIONS	MIN	TYP	MAX	UNIT
Input Supply Range	V_{CC}		2.6		5.5	V
Disable Supply Current	$I_{Disable}$	EN=GND		0.1	10	μA
Standby Supply Current	I_{SBY}	$V_{FB}=1.3V$		0.20	0.35	mA
Average Supply Current	I_{AVG}	$V_{FB}=1.0V$		2.0	5.0	mA

TYPICAL CHARACTERISTICS

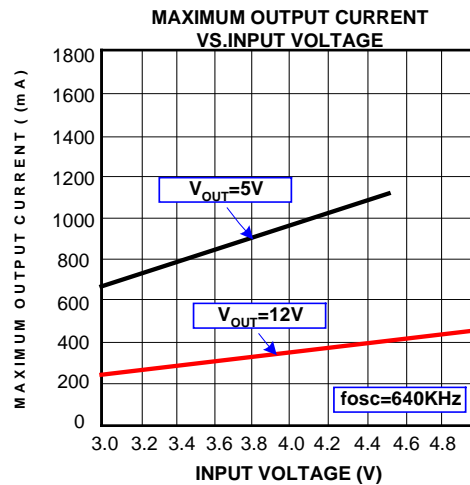
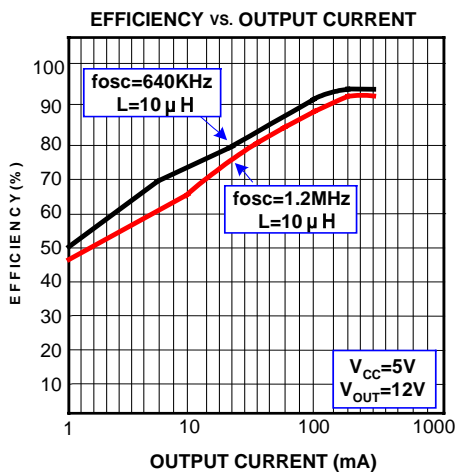
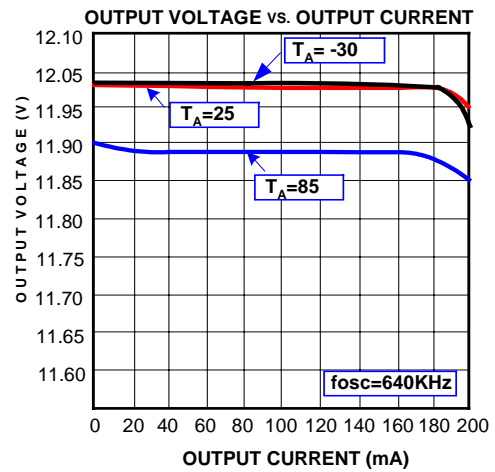
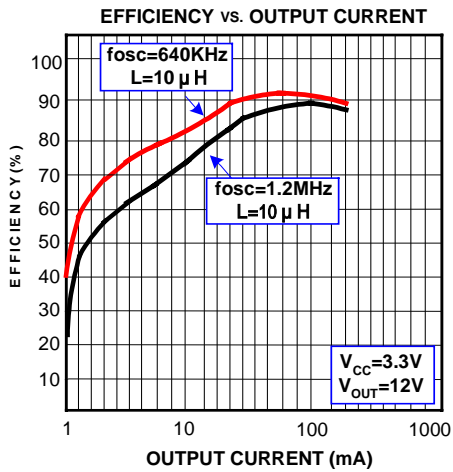
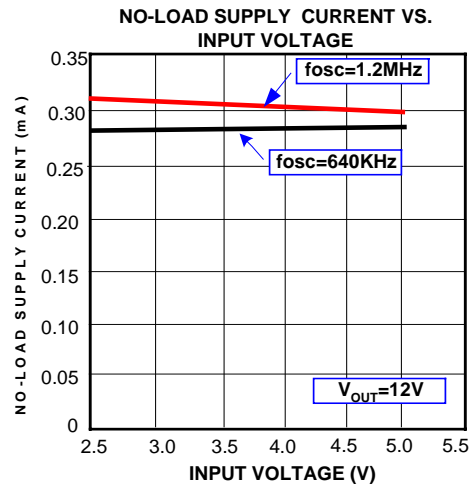
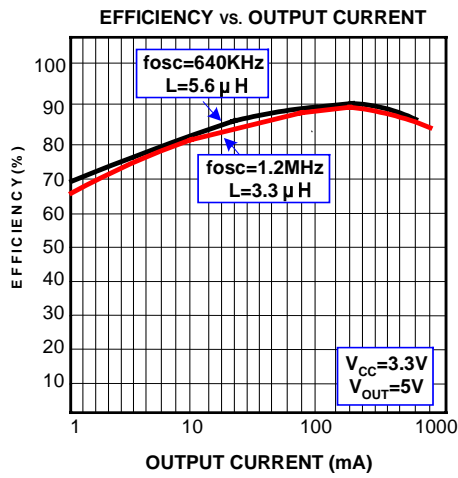

TYPICAL CHARACTERISTICS (Cont.)

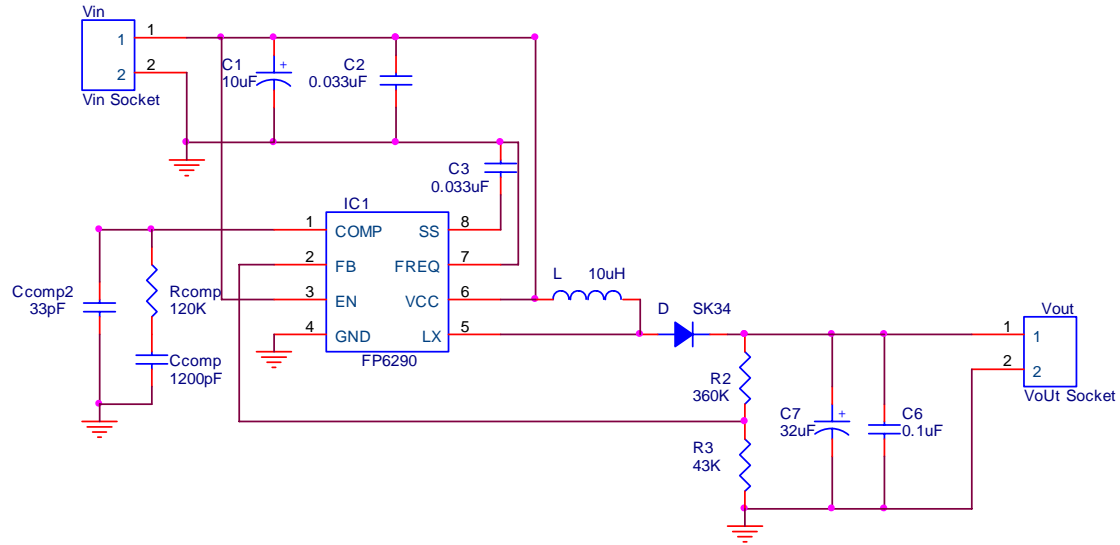

Application Circuit

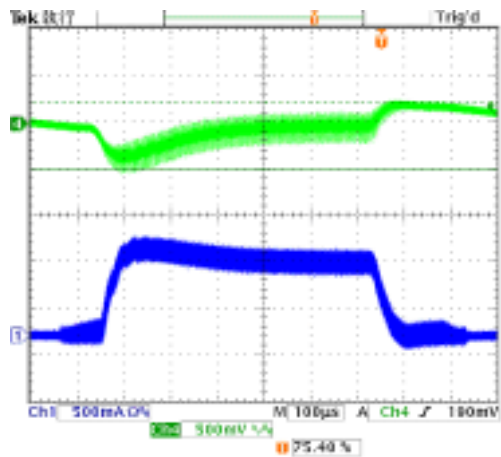

Ch1=Inductor Current
 Ch4=Output AC-Coupled
 Vcc=3.3V, Vout=12V
 Freq=640KHz
 I_{LOAD}=10mA~200mA

LOAD-TRANSIENT RESPONSE

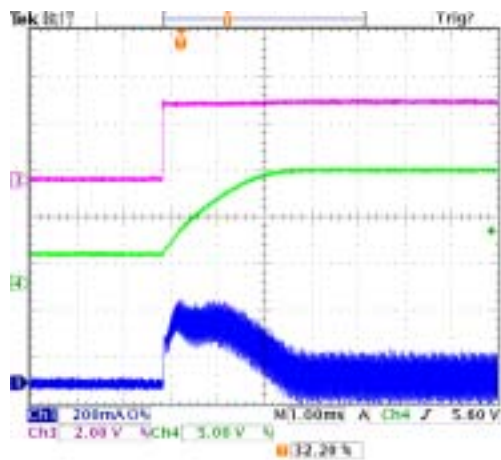

Ch1=Inductor Current
 Ch3=EN
 CH4=Vout
 Vcc=3.3V, Vout=12V
 I_{LOAD}=10mA
 Freq=640KHz

START UP WAVEFORM WITH SOFT-START

TYPICAL CHARACTERISTICS (Cont.)

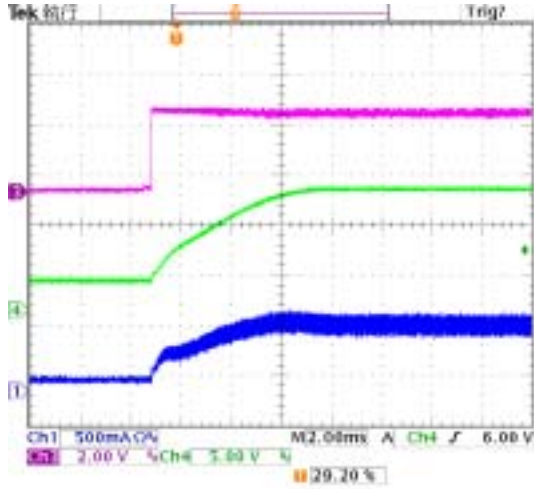

START UP WAVEFORM WITH SOFT-START

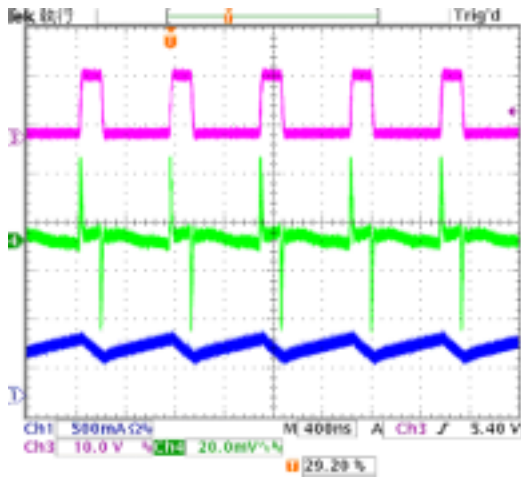

SWITCHING WAVEFORM

DETAILED DESCRIPTION

Voltage reference

A 1.24V reference regulator supplies **FP6290** internal circuits on the non-inverting terminal of error amplifier.

Error amplifier

The error amplifier compares a sample of the dc-dc converter output voltage to the 1.24V(Vref) reference and generates an error signal for the PWM comparator. Output voltage of dc-dc converter is setting with the resistor divider using the following expression :

$$V_{out} = \left(1 + \frac{R1}{R2}\right) * 1.24$$

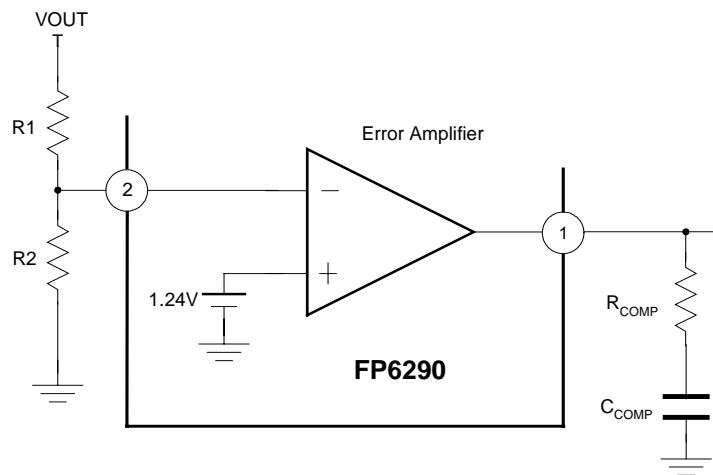

Oscillator

The switching frequency of **FP6290** can be selected to operate at either 640KHz or 1.2MHz. When the FREQ pin is connected to GND for 640KHz operation, and connected to VCC for 1.2MHz operation. FREQ has an internal pull-down current about 5 μ A, allowing the user the option of leaving FREQ unconnected for 640KHz operation.

Soft Start

The soft start is functional after power on, and the interval of soft start time is determined by a capacitor connected to SS pin (pin 2). When EN pin is taken high, the soft start capacitor (C_{SS}) is charged at a constant current of 4 μ A (typ). During this time, the SS voltage directly controls the peak inductor current. The maximum load current is available after the soft-start cycle is completed. When the EN pin is taken low, the soft-start capacitor is discharged to ground for next start up.

The load must wait for the soft-start cycle to finish before drawing a significant amount of load current. The duration after which the load can begin to draw maximum load current is:

$$T_{MAX} = 6.77 * 10^5 C_{SS}$$

EN

The **FP6290** is turn off to reduce the supply current to 0.1 μ A when EN is low. In this mode, the internal reference, error amplifier, comparators, and biasing circuitry turn off while the N-channel MOSFET is turned off. The boost converter's output is connected to VCC by the external inductor and catch diode.

Output Current Capability

The output current capability of the **FP6290** is a function of current limit, input voltage, operation frequency, and inductor value. Because of the slope compensation used to stabilize the feedback loop, the duty cycle affects the current limit. The output current capability is governed by the following equation:

$$I_{OUT(MAX)} = [I_{LIM} * (1.26 - 0.4 * Duty) - 0.5 * Duty * V_{IN} / (f_{osc} * L)] * \eta * V_{IN} / V_{OUT}$$

Where:

I_{LIM} =current limit specified at 65%

$$Duty = \text{duty cycle} = \frac{(V_{OUT} - V_{IN} + V_{DIODE})}{V_{OUT} - I_{LIM} * R_{ON} + V_{DIODE}}$$

V_{DIODE} =catch diode forward voltage at I_{LIM}

=conversion efficiency, 85% nominal

Current Limitation

The power-MOS switch current is monitored cycle-by-cycle and is limited to the value not exceed 1.6A (typ). When the switch current reaches the limited value, the power-MOS is turned off immediately until the next cycle.

APPLICATION NOTE

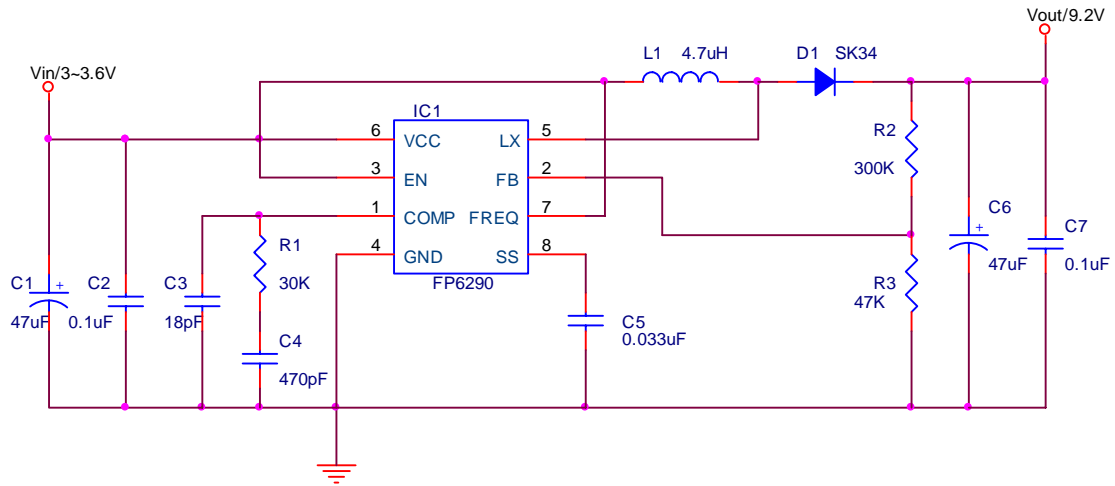

Figure 1 FP6290 Typical Application Circuits

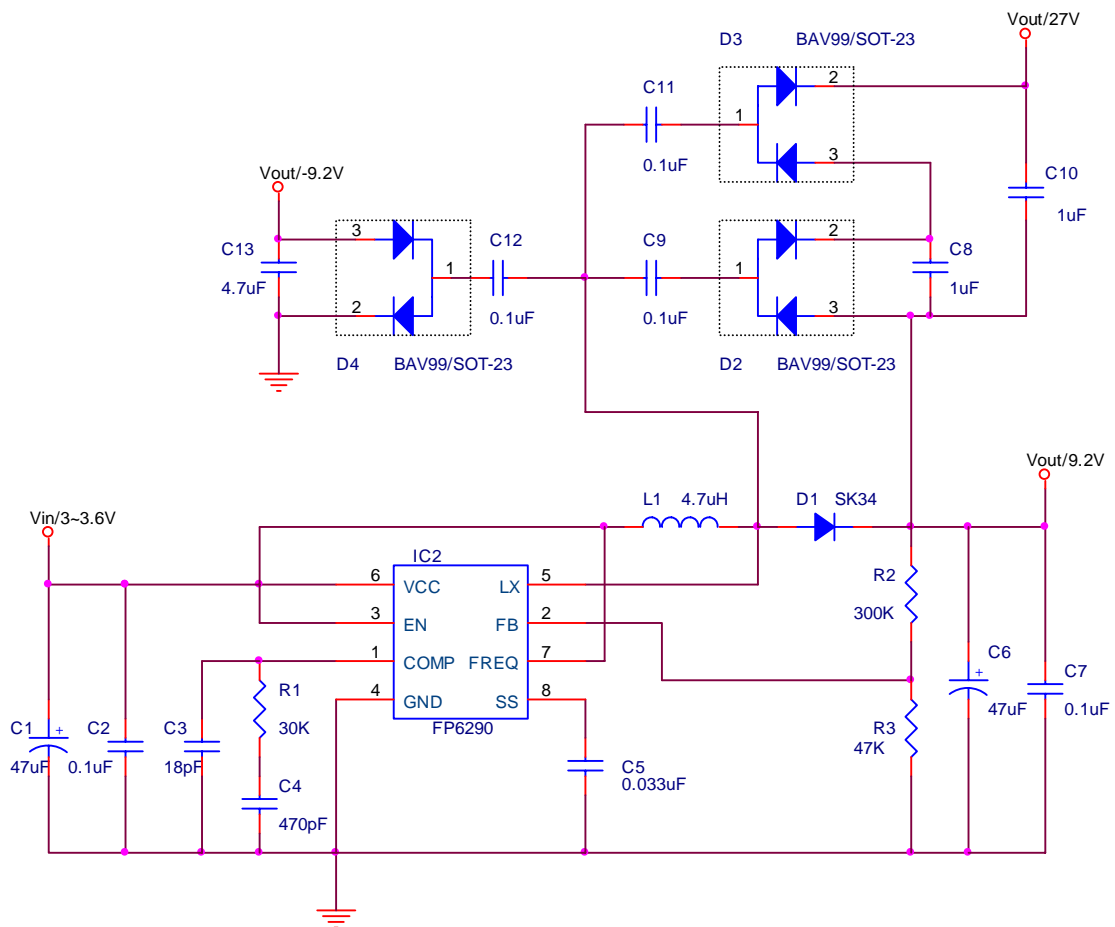
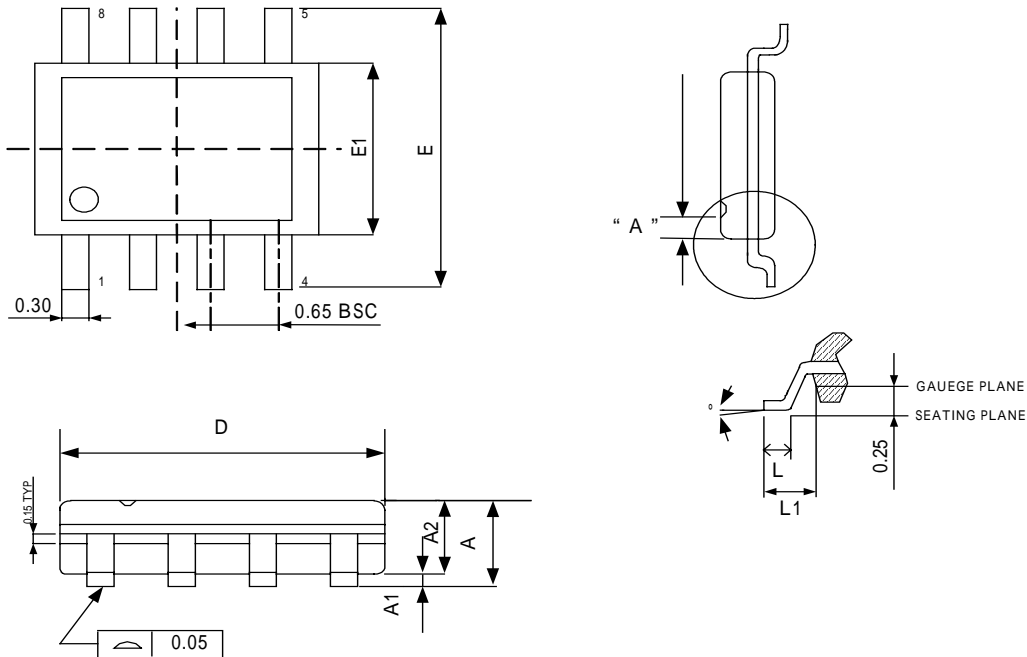

Figure 2 FP6290 TFT Panel Power Supply Application Circuits

PACKAGE OUTLINE

MSOP-8L



SYMBOLS	MIN	MAX
A	-	1.10
A1	0.00	0.15
A2	0.75	0.95
D	3.00 BSC	
E	4.90 BSC	
E1	3.00 BSC	
L	0.40	0.80
L1	0.95 REF	
°	0	8

UNIT:MM

NOTE:

- 1.JEDEC OUTLINE:MO-187 AA
- 2.DIMENSIONS "D" DOES NOT INCLUDE MOLD FLASH,PROTRUSIONS OR GATE BURRS.MOLD FLASH,PROTRUSIONS AND GATE BURRS SHALL NOT EXCEED 0.15 PER SIDE
- 3.DIMENSIONS "E1" DOES NOT INCLUDE INTERLEAD FLASH,OR PROTRUSIONS. INTERLEAD FLASH OR PROTRUSIONS SHALL NOT EXCEED 0.25 PER SIDE.
- 4.DIMENSIONS "0.22" DOES NOT INCLUDE DAMBAR PROTRUSIONS.ALLOWABLE DAMBAR PROTRUSIONS SHALL BE 0.08 MM TOTAL IN EXCESS OF THE '0.22' DIMENSION AT MAXIMUM MATERIAL CONDITION.DAMBAR CANNOT BE LOCATED ON THE LOWER RADIUS OF THE FOOT.MINIMIM SPAC BETWEEN PROTRUSION AND ADJACENT LEAD IS 0.07MM.
- 5.DIMENSIONS "D" AND 'E1' TO BE DETERMINED AT DATUM PLANE H

PACKING SPECIFICATIONS

BOX DIMENSION

TUBE INSIDE BOX AND CARTON

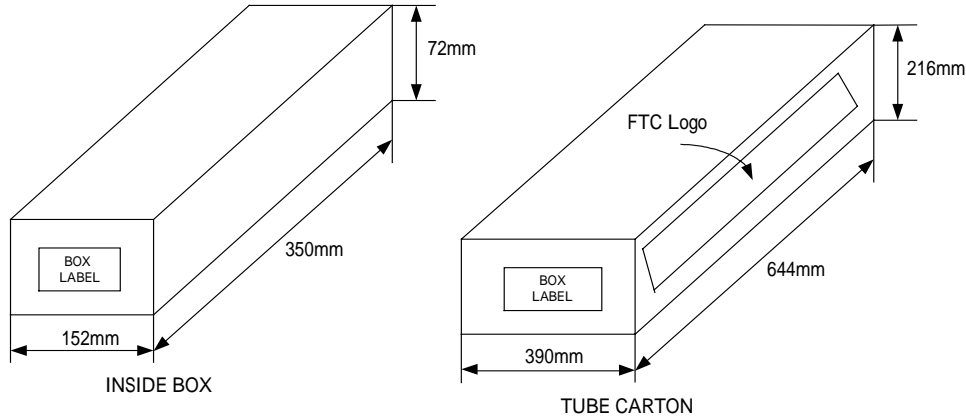

TAPE AND REEL INSIDE BOX AND CARTON

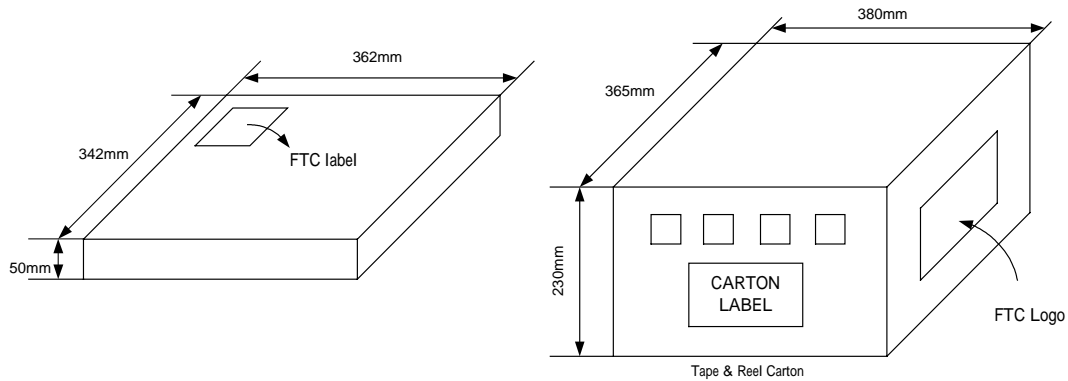

PACKING QUANTITY SPECIFICATIONS

80 EA/TUBE	2500 EA / REEL
200 TUBES / INSIDE BOX	4 INSIDE BOXES / CARTON
8 INSIDE BOXES / CARTON	

LABEL SPECIFICATIONS

TAPPING & REEL

Feeling Technology Corp.	
Product	FP6290TR-LF
Lot No	A3311C62
D/C	6Xx-62L
Q'ty	2500
無鉛 Lead Free	

CARTON

Feeling Technology Corp.	
Product Type:	FP6290TR-LF
Lot No:	A3311C62
Date Code:	6Xx-62L
Package Type:	MSOP-8L
Marking Type:	Laser
Total Q'ty:	10,000
無鉛 Lead Free	

MSOP8

CARRIER TAPE DIMENSIONS

APPLICATION	W	P	E	F	D	D ₁
MSOP8	12.0±3	8.0	1.75±1.0	5.5±0.5	1.5 ^{+0.1}	1.50

APPLICATION	P ₀	P ₁	A _D	B ₀	K ₀	t
MSOP8	4.0±0.1	2.0±0.5	4.20	3.30	1.20	0.30±0.5

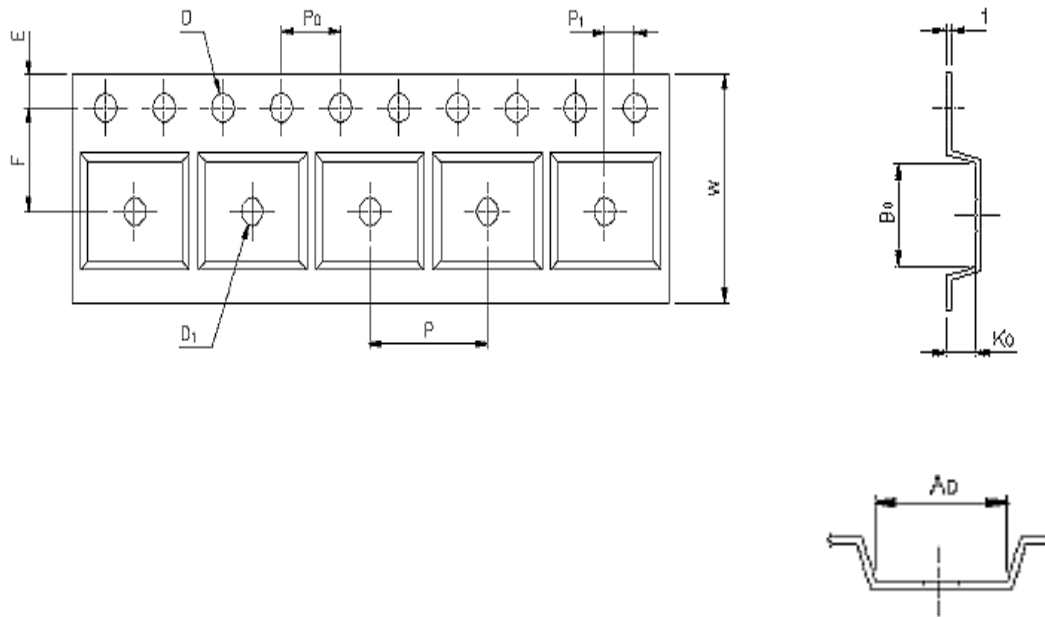

REEL DIMENSIONS

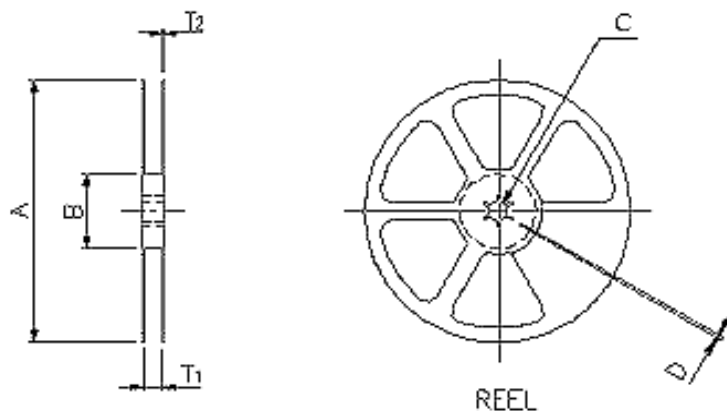

APPLICATION	MATERIAL	A	B	C	D	T ₁	T ₂
MSOP8	PLASTIC REEL	330±1	62±1.5	12.75 ^{+0.15}	2±0.15	12.4 ^{+0.2}	16.8 ^{-0.4}