



Description

SE1051 is a highly integrated solution for SMPS applications requiring CV (constant voltage) and CC (constant current) modes.

SE1051 integrates one voltage reference, two operational amplifiers (the outputs are OR'ed together, common collectors), and a current sensing circuit.

The voltage reference, together with one operational amplifier, makes it an ideal voltage controller. The other low voltage reference, together with another operational amplifier, makes it an ideal current limiter for low side output current sensing. The current threshold is fixed, and precise. The SE1051, housed in space-saving SOT23-6L package, is ideal for space sensitive applications such as adapters, cellphone chargers, Digital Camera chargers, and other battery chargers.

Features

- Constant Voltage and Constant Current Control
- Low Voltage Operation
- Precision Internal Voltage Reference
- Low External Component Count
- Current Sink Output Stage
- Easy Compensation
- Low AC Mains Voltage Rejection
- Rugged 2KV ESD withstand capability.
- Available in SOT-23-6L Package.
- RoHS Compliant and 100% Lead (Pb)-Free

Application

- Adapters
- Digital Camera Chargers.
- Cellphone Chargers.
- Other Battery Chargers

Pin Configuration

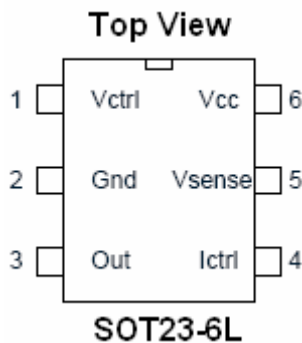

Ordering Information

Device	Package	V _{OUT}
SE1051	SOT-23-6L (Lead-free)	Fixed output voltages 1.21V

Pin Description

Name	Pin#	Type	Function
V _{CTRL}	1	Analog Input	Input Pin of the Voltage Control Loop
GND	2	Power Supply	Ground Line. 0V Reference For All Voltages
V _{OUT}	3	Current Sink Output	Output Pin. Sinking Current Only
I _{CTRL}	4	Analog Input	Input Pin of the Current Control Loop
V _{SENSE}	5	Analog Input	Input Pin of the Current Control Loop
V _{CC}	6	Power Supply	Positive Power Supply Line



Absolute Maximum Rating

Symbol	Parameter	Maximum	Units
V_{CC}	DC Supply Voltage	18	V
V_{IN}	Input Supply Voltage	-0.3~ V_{CC}	V
θ_{JA}	Thermal Resistance Junction to Ambient	250	°C/W
T_J	Operating Junction Temperature Range	0 to 125	°C
T_{STG}	Storage Temperature Range	-40 to 150	°C
T_{LEAD}	Lead Temperature (Soldering 10 Sec)	260	°C

Electrical Characteristic

$V_{CC} = 5.0V$, $T_A = 25^\circ C$, unless otherwise specified.

Symbol	Parameter	Test Condition	Min	Typ	Max	Unit
Total Current Consumption						
I_{CC}	Total Supply Current - not taking the output sinking current into account			0.4		mA
		$0 < T_A < 85^\circ C$		0.5		
Voltage Control Loop						
G_{mv}	Transconduction Gain (V_{CTRL}). Sink Current Only ¹⁾			2.4		mA/mV
		$0 < T_A < 85^\circ C$		2.0		
V_{REF}	Voltage Control Loop Reference ²⁾			1.21		V
		$0 < T_A < 85^\circ C$				
I_{IBV}	Input Bias Current (V_{CTRL})			50		nA
		$0 < T_A < 85^\circ C$		100		
Current Control Loop						
G_{mi}	Transconduction Gain (I_{CTRL}). Sink Current Only ³⁾	$0 < T_A < 85^\circ C$		2.9		mA/mV
V_{SENSE}	Current Control Loop Reference ⁴⁾	$I_{OUT} = 2.5mA$		200		mV
		$0 < T_A < 85^\circ C$				
I_{IBI}	Current out of pin I_{CTRL} at -200mV			25		μA
		$0 < T_A < 85^\circ C$		50		
Output Stage						
V_{OL}	Low output voltage at 10 mA sinking current	$0 < T_A < 85^\circ C$		300		mV
I_{OS}	Output Short Circuit Current. Output to V_{CC} . Sink Current Only			22		mA
		$0 < T_A < 85^\circ C$		35		

1. If the voltage on V_{CTRL} (the negative input of the amplifier) is higher than the positive amplifier input ($V_{REF}=1.210V$), and it is increased by 1mV, the sinking current at the output OUT will be increased by 2.4mA.
2. The internal Voltage Reference is set at 1.210V. The internal Voltage Reference is fixed by bandgap, and trimmed to 0.5% accuracy at room temperature.
3. When the positive input at I_{CTRL} is lower than -200mV, and the voltage is decreased by 1mV, the sinking current at the output OUT will be increased by 2.9mA.
4. The internal current sense threshold is set to -200mV. The current control loop precision takes into account the cumulative effects of the internal voltage reference deviation as well as the input offset voltage of the trans-conduction operational amplifier.



Typical Application

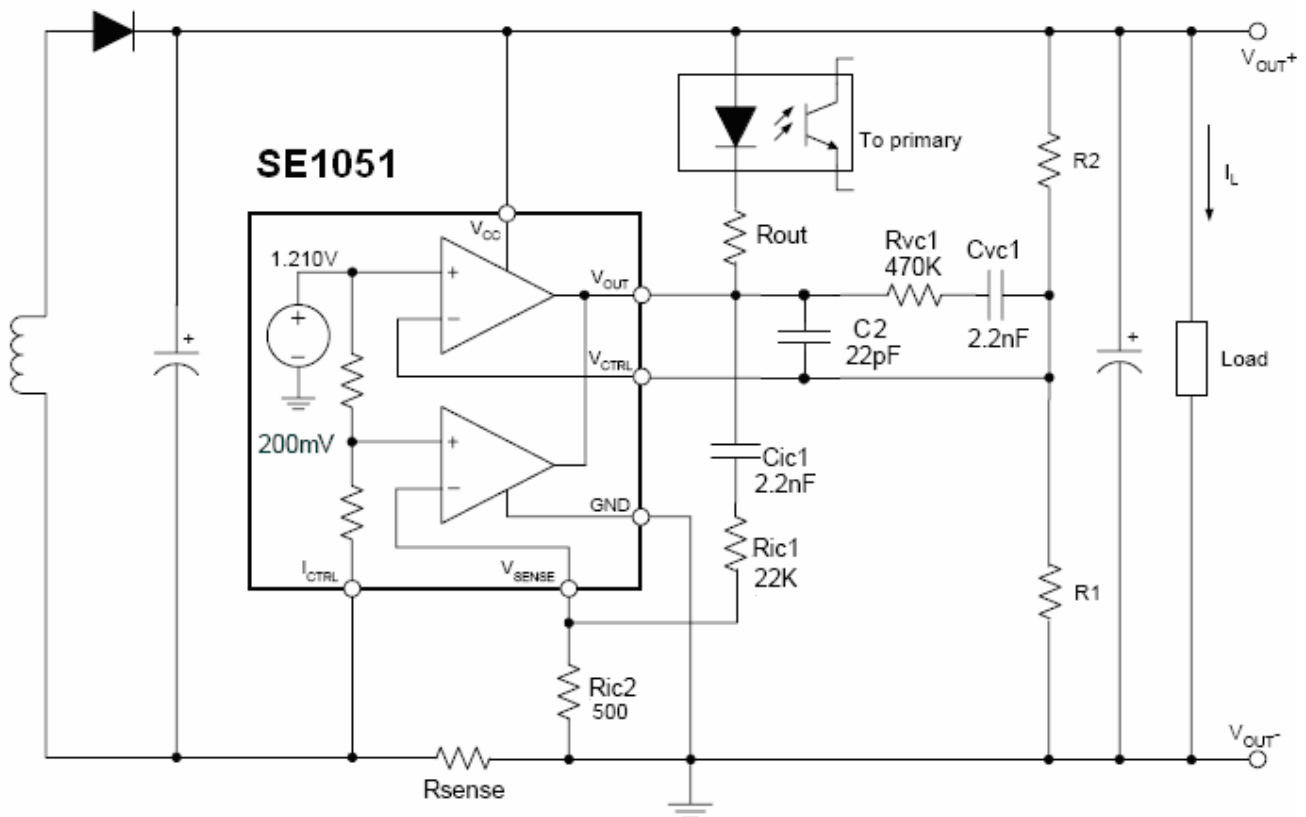

Fig.1 Typical Adapter or Battery Charger Application Using SE1051

In the above application schematic, the SE1051 is used on the secondary side of a flyback adapter (or battery charger) to provide an accurate control of voltage and current. The above feedback loop is made with an optocoupler.

$$V_{OUT} = V_{REF} \times \frac{R1 + R2}{R1}$$

$$I_{LIMIT} = \frac{V_{SENSE}}{R_{SENSE}}$$



Application Hints

Voltage Control

The voltage loop is controlled via a first transconductance operational amplifier, the resistor bridge R1, R2, and the optocoupler which is directly connected to the output.

The relation between the values of R1 and R2 should be chosen as written in Equation 1.

$$R1 = R2 \times Vref / (Vout - Vref) \quad Eq1$$

Where Vout is the desired output voltage. To avoid the discharge of the load, the resistor bridge R1, R2 should be highly resistive. For this type of application, a total value of 100KΩ (or more) would be appropriate for the resistors R1 and R2. As an example, with R2 = 100KΩ, Vout = 4.10V, Vref = 1.210V, then R1 = 41.9KΩ.

Note that if the low drop diode should be inserted between the load and the voltage regulation resistor bridge to avoid current flowing from the load through the resistor bridge, this drop should be taken into account in the above calculations by replacing Vout by (Vout + Vdrop).

Current Control

The current loop is controlled via the second trans-conductance operational amplifier, the sense resistor Rsense, and the optocoupler.

The control equation is:

$$Rsense \times I\text{-limit} = Vsense \quad Eq2$$

$$Rsense = Vsense / I\text{-limit} \quad Eq3$$

where I-limit is the desired current limit, and Vsense is the threshold voltage for the current control loop.

As an example, with I-limit = 1A, Vsense = -200mV, then Rsense = 200mΩ.

Note that the Rsense resistor should be selected with the consideration of the Maximum Power in full load operations (P-limit).

$$P\text{-limit} = Vsense \times I\text{-limit} \quad Eq4$$

As an example, with I-limit = 1A, and Vsense = -200mV, P-limit = 200mW.

Consequently, for most adapter and battery charger applications, a quarter-watt resistor to make the current sensing function is sufficient.

Vsense threshold is achieved internally by a resistor bridge tied to the Vref voltage reference. Its middle point is tied to the positive input of the current control operational amplifier, and its foot is to be connected to lower potential point of the sense resistor as shown on the following figure. The resistors of this bridge are matched in layout to provide the best precision possible.

The current sinking outputs of the two trans-conductance operational amplifiers are connected together. This makes an ORing function which ensures that whenever the current or the voltage reaches too high values, the optocoupler is activated.

The relation between the controlled current and the controlled output voltage can be described with a square characteristic as shown in the following V/I output-power graph.

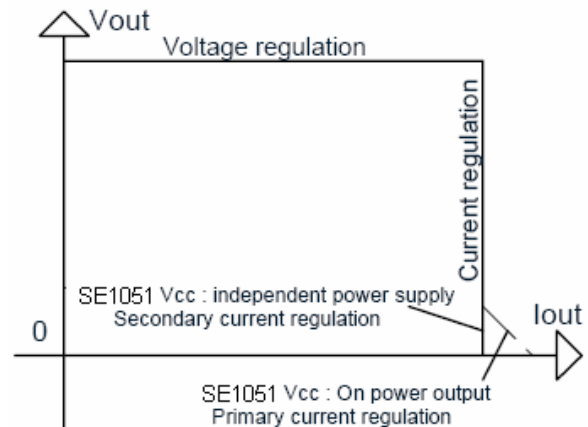

Fig.2 Output voltage versus output current

Compensation

The voltage-control trans-conductance operational amplifier can be fully compensated. Both of its output and negative input are directly accessible for external compensation components.

An example of a suitable compensation network is shown in Fig.1. It consists of a capacitor Cvc1=2.2nF and a resistor Rcv1=470KΩ in series, connected in parallel with another capacitor Cvc2=22pF.

The current-control trans-conductance operational amplifier can also be fully compensated. Both of its output and negative input are directly accessible for external compensation components.

An example of a suitable compensation network is shown in Fig.1. It consists of a capacitor Cic1=2.2nF and a resistor Ric1=22KΩ in series. When the Vcc voltage reaches 12V it could be interesting to limit the current coming through the output in the aim to reduce the dissipation of the device and increase the stability performances of the whole application.

An example of a suitable Rout value could be 330Ω in series with the opto-coupler in case Vcc=12V.



Start Up and Short Circuit Conditions

Under start-up or short-circuit conditions the SE1051 does not have a high enough supply voltage. This is due to the fact that the chip has its power supply line in common with the power supply line of the charger system. Consequently, the current limitation can only be ensured by the primary PWM module, which should be designed accordingly.

If the primary current limitation is considered not to be precise enough for the application, then a sufficient supply for the SE1051 has to be ensured under any condition. It would then be necessary to add some circuitry to supply the chip with a separate power line. This can be achieved in numerous ways, including an additional winding on the transformer.

The following schematic shows how to realize a low-cost power supply for the SE1051 (with no additional windings).

Please pay attention to the fact that in the particular case presented here, this low-cost power supply can reach voltages as high as twice the voltage of the regulated line. Since the Absolute Maximum Rating of the SE1051 supply voltage is 18V, this low-cost auxiliary power supply can only be used in applications where the regulated line voltage does not exceed 9V.

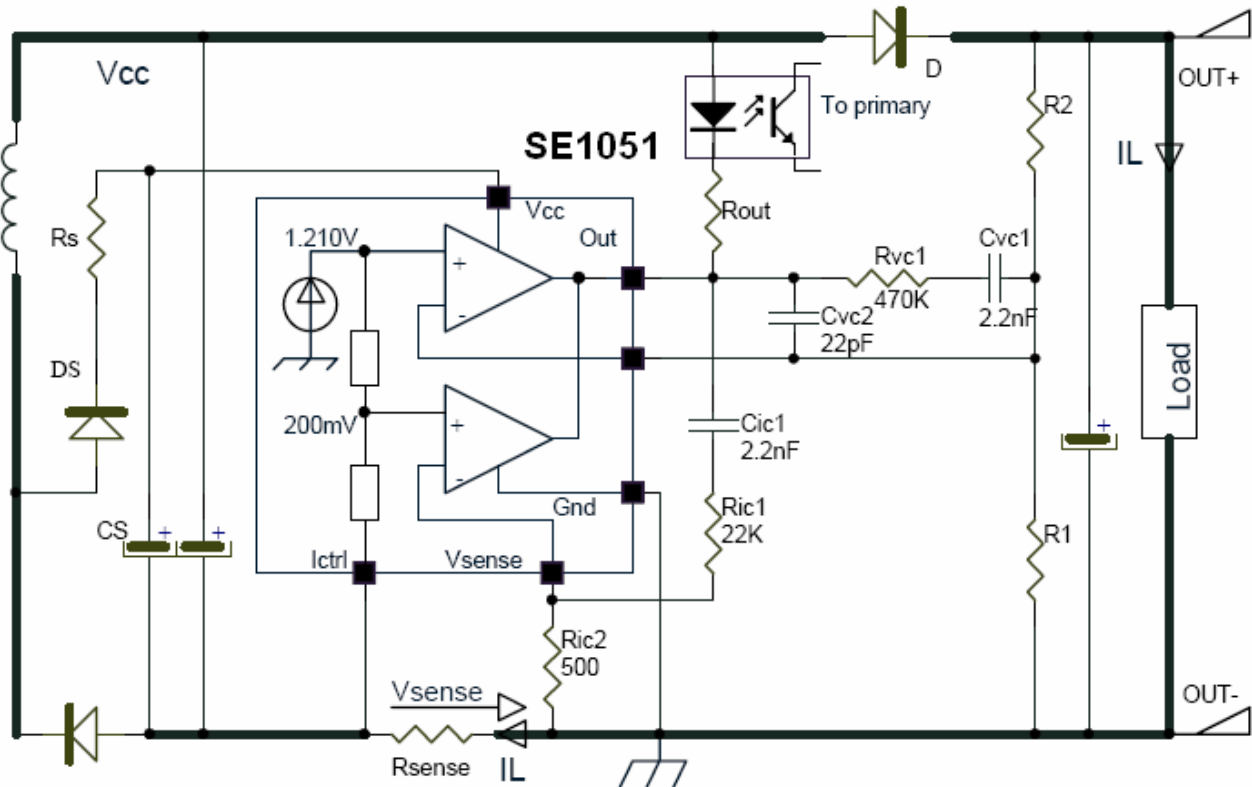
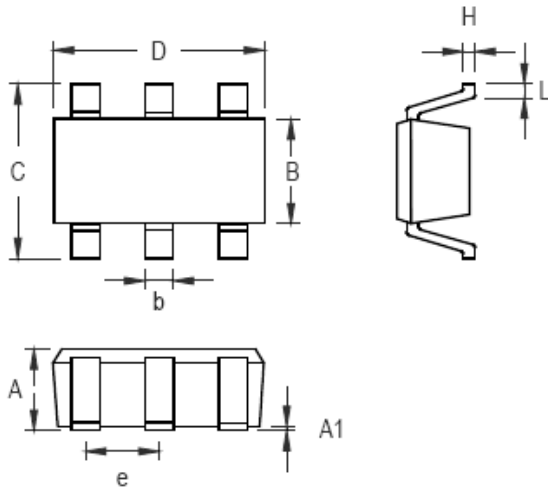

Fig. 3



OUTLINE DRAWING SOT-23-6L



Symbol	Dimensions In Millimeters		Dimensions In Inches	
	Min	Max	Min	Max
A	0.889	1.295	0.031	0.051
A1	0.000	0.152	0.000	0.006
B	1.397	1.803	0.055	0.071
b	0.250	0.560	0.010	0.022
C	2.591	2.997	0.102	0.118
D	2.692	3.099	0.106	0.122
e	0.838	1.041	0.033	0.041
H	0.080	0.254	0.003	0.010
L	0.300	0.610	0.012	0.024

Customer Support

Seaward Electronics Incorporated – China

Rm 1605, Building 1, International Pioneering Park, #1 Shangdi Xinxu Rd

Haidian District, Beijing 100085, China

Tel: 86-10-8289-5700/01/05

Fax: 86-10-8289-5706

Seaward Electronics Corporation – Taiwan

2F, #181, Sec. 3, Minquan East Rd,

Taipei, Taiwan R.O.C

Tel: 886-2-2712-0307

Fax: 886-2-2712-0191

Seaward Electronics Incorporated – North America

1512 Centre Pointe Dr.

Milpitas, CA95035, USA

Tel: 1-408-821-6600

Agent: SHENZHEN FULLPOWER ELECT-TECH CO.,LTD.

TEL:+86-755-83011898

FAX:+86-755-82861919

SUPPORT LINE:+86-13828816686

Last Updated - 9/6/2007