

**2A, 23V, 380KHz  
Step-Down Converter**

**GENERAL DESCRIPTION**

The **FP6182** is a buck regulator with a built in internal power MOSFET. It achieves 2A continuous output current over a wide input supply range with excellent load and line regulation. Current mode operation provides fast transient response and eases loop stabilization. The device includes cycle-by-cycle current limiting and thermal shutdown protection. Adjustable soft-start reduced the stress on the input source at power-on. The regulator only consumes 23 $\mu$ A supply current in shutdown mode. The FP6182 requires a minimum number of readily available external components to complete a 2A buck regulator solution.

**FEATURES**

- 2A Output Current
- Adjustable Soft-Start
- 0.22 $\Omega$  Internal Power MOSFET Switch
- Stable with Low ESR Output Ceramic Capacitors
- Up to 95% Efficiency
- 23 $\mu$ A Shutdown Mode Current
- Fixed 380KHz frequency
- Thermal Shutdown
- Cycle-by-Cycle Over Current Protection
- Wide 4.75 to 23V operating Input Range
- Output Adjustable From 1.222 to 16V
- Available SOP8 & PDIP8 Package
- Under Voltage Lockout

**APPLICATIONS**

- Distributed Power Systems
- Battery Charger
- Pre-Regulator for Linear Regulators
- DSL Modems

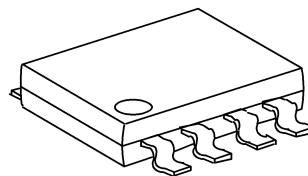

SOP8

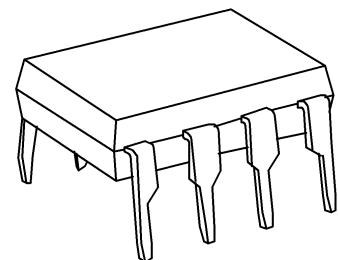

PDIP8

**TYPICAL APPLICATION CIRCUIT**

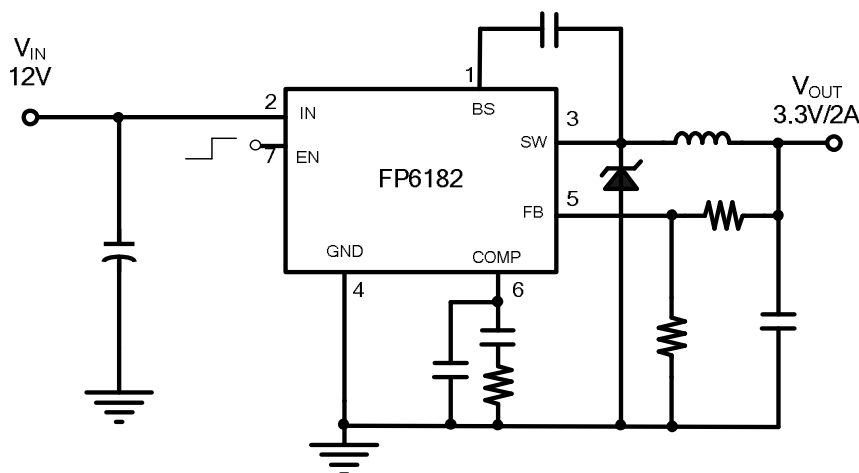



**ORDER INFORMATION**

Part Number	Operating Temperature	Package	Description
FP6182DR-LF	-40°C ~ +85°C	SOP8	Tape & Reel
FP6182D-LF	-40°C ~ +85°C	SOP8	Tube
FP6182P-LF	-40°C ~ +85°C	PDIP8	Tube

**IC DATE CODE DISTINGUISH**

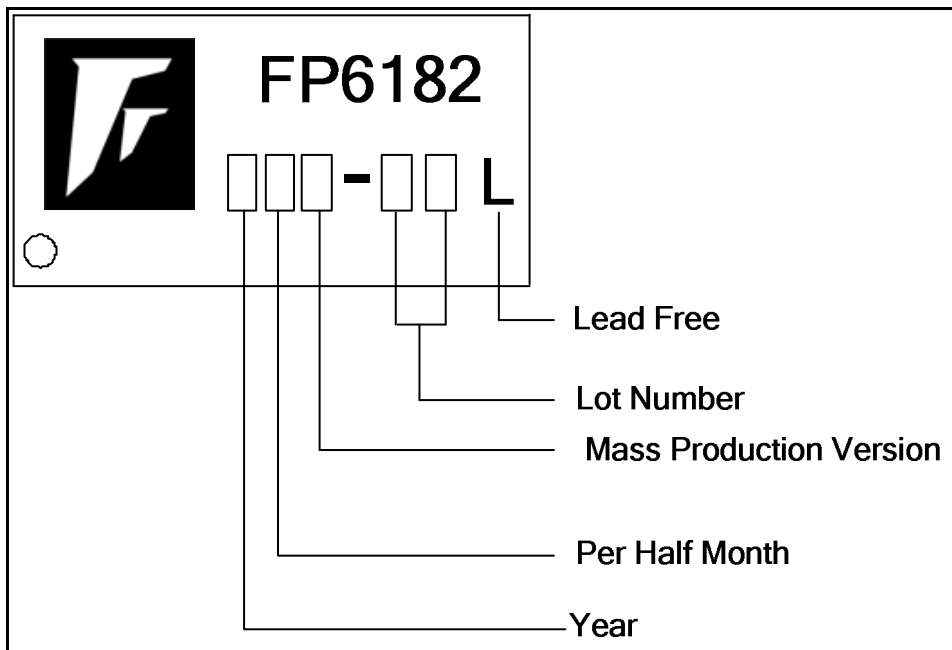

**For example:**

- 1 – Year 2001
- 2 – Year 2002
- 3 – Year 2003 ----- And so on

Lot Number is the last two numbers

**For example:**

A3311C62  
 ↳ Lot Number

**ABSOLUTE MAXIMUM RATINGS**

Supply Voltage ( $V_{IN}$ )	-0.3V to 24V
Switch Voltage ( $V_{SW}$ )	-1V to $V_{IN} + 0.3V$
Bootstrap Voltage ( $V_{BS}$ )	$V_{SW} - 0.3V$ to $V_{SW} + 6V$
All Other Pins	-0.3V to 6V
Junction Temperature	150°C
Storage Temperature	-65°C to 150°C
Allowable Power Dissipation ( $T_a \leq +25^\circ C$ )	
SOP8	570mW
PDIP	800mW
Thermal Resistance(Junction to Ambient, $\theta_{JA}$ )	
SOP8	175°C/W
PDIP8	125°C/W
Lead Temperature (soldering, 10 sec)	
SOP8	+260°C
PDIP8	+270°C

**Recommended Operating Conditions**

Supply Voltage ( $V_{IN}$ )	4.75~23V
Operating temperature	-40°C ~ +85°C

**DC ELECTRICAL CHARACTERISTICS**( $T_a = 25^\circ\text{C}$ ,  $V_{IN} = 12\text{V}$ , unless otherwise noted)

PARAMETER	SYMBOL	TEST CONDITIONS	MIN	TYP	MAX	UNIT
Standby Current	$I_{ST}$	$V_{EN} \geq 3\text{V}, V_{FB} \geq 1.5\text{V}$		1.0	1.5	mA
Shutdown Supply Current	$I_{ST}$	$V_{EN} = 0$		25	50	$\mu\text{A}$
Feedback Voltage	$V_{FB}$	$V_{IN} = 12\text{V}, V_{COMP} < 2\text{V}$	1.184	1.222	1.258	V
High Side Switch ON Resistance	$R_{ON-HS}$			0.22		$\Omega$
Low Side Switch ON Resistance	$R_{ON-LS}$			10		$\Omega$
High Side Switch Leakage Current	$I_{IL}$	$V_{EN} = 0, V_{SW} = 0\text{V}$		0.1	10	$\mu\text{A}$
Current Limit	$I_{CL}$		2.8	3.4		A
Oscillation Frequency	$f_{OSC}$			380		KHz
Short Circuit Oscillation Frequency	$f_{SC}$	$V_{FB} = 0\text{V}$		42		KHz
Maximum Duty Cycle	$D_{MAX}$	$V_{FB} = 1.0\text{V}$		90		%
Minimum Duty Cycle	$D_{MIN}$	$V_{FB} = 1.5\text{V}$			0	%
Under Voltage Lockout Threshold	$V_{UVLO}$	$V_{EN}$ Rising	2.0	2.5	3.0	V
Under Voltage Lockout Threshold Hysteresis	$V_{HYS}$			200		mV
EN Threshold Voltage	$V_{EN}$	$I_{CC} > 100\mu\text{A}$	0.7	1.0	1.3	V
Enable Pull Up Current	$I_{EN}$	$V_{EN} = 0\text{V}$		1.0		$\mu\text{A}$
Thermal Shutdown	$T_{TS}$			140		$^\circ\text{C}$

## Function Description

The FP6182 is a current-mode buck regulator. It regulates input voltages from 4.75V to 23V down to an output voltage as low as 1.222V, and is able to supply up to 2A of load current.

The FP6182 uses current-mode control to regulate the output voltage. The output voltage is measured at FB through a resistive voltage divider and amplified through the internal error amplifier. The output current of the transconductance error amplifier is presented at COMP where a network compensates the regulation control system. The voltage at COMP is compared to the switch current measured internally to control the output voltage.

The converter uses an internal n-channel MOSFET switch to step-down the input voltage to the regulated output voltage. Since the MOSFET requires a gate voltage greater than the input voltage, a boost capacitor connected between SW and BS drives the gate.

The capacitor is internally charged while the switch is off. An internal  $10\Omega$  switch from SW to GND is used to insure that SW is pulled to GND when the switch is off to fully charge the BS capacitor.

## Output Voltage( $V_{OUT}$ )

The output voltage is set using a resistive voltage divider from the output voltage to FB. The voltage divider divides the output voltage down by the ratio:

$$V_{FB} = V_{OUT} \times R2 / (R1 + R2)$$

Thus the output voltage is:

$$V_{OUT} = 1.222 \times (R1 + R2) / R2$$

A typical value for R2 can be as high as 100k, but a typical value is 10K.

## Shutdown Mode

Drive enable Pin to ground to shut down the FP6182. Shutdown forces the internal power MOSFET off, turns off all internal circuitry, and reduces the  $V_{IN}$  supply current to  $25\mu A$  (typ). The enable Pin rising threshold is 1.0V(typ). Before any operation begins, the voltage at Enable Pin must exceed 1.0V (typ).

## Boost High-Side Gate Drive(BST)

Since the MOSFET requires a gate voltage greater than the input voltage, connect a flying bootstrap capacitor between SW and BS to provide the gate-drive voltage to the high-side n-channel MOSFET switch. The capacitor is alternately charged from the internally regulator.

On startup, an internal low-side switch connects SW to ground and charges the BST capacitor to internally regulator voltage. Once the BST capacitor is charged, the internal low-side switch is turned off and the BST capacitor voltage provides the necessary enhancement voltage to turn on the high-side switch.

---

**Function Description(cont.)****Thermal Shutdown Protection**

The FP6182 features integrated thermal shutdown protection. Thermal shutdown protection limits allowable power dissipation( $P_D$ ) in the device, and protects the device in the event of a fault condition. When the IC junction temperature exceeds  $+140^{\circ}\text{C}$ , an internal thermal sensor signals the shutdown logic, turning off the internal power MOSFET and allowing the IC to cool down. The thermal sensor turns the internal power MOSFET back on after the IC junction temperature cools down to  $+110^{\circ}\text{C}$ , resulting in a pulsed output under continuous thermal overload conditions.

## APPLICATIONS INFORMATION

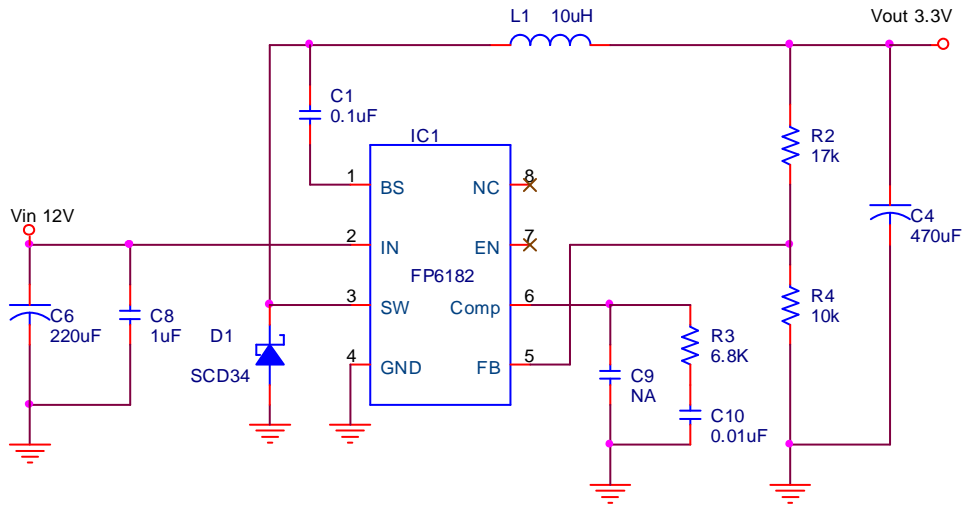



PACKAGE OUTLINE

SOP8

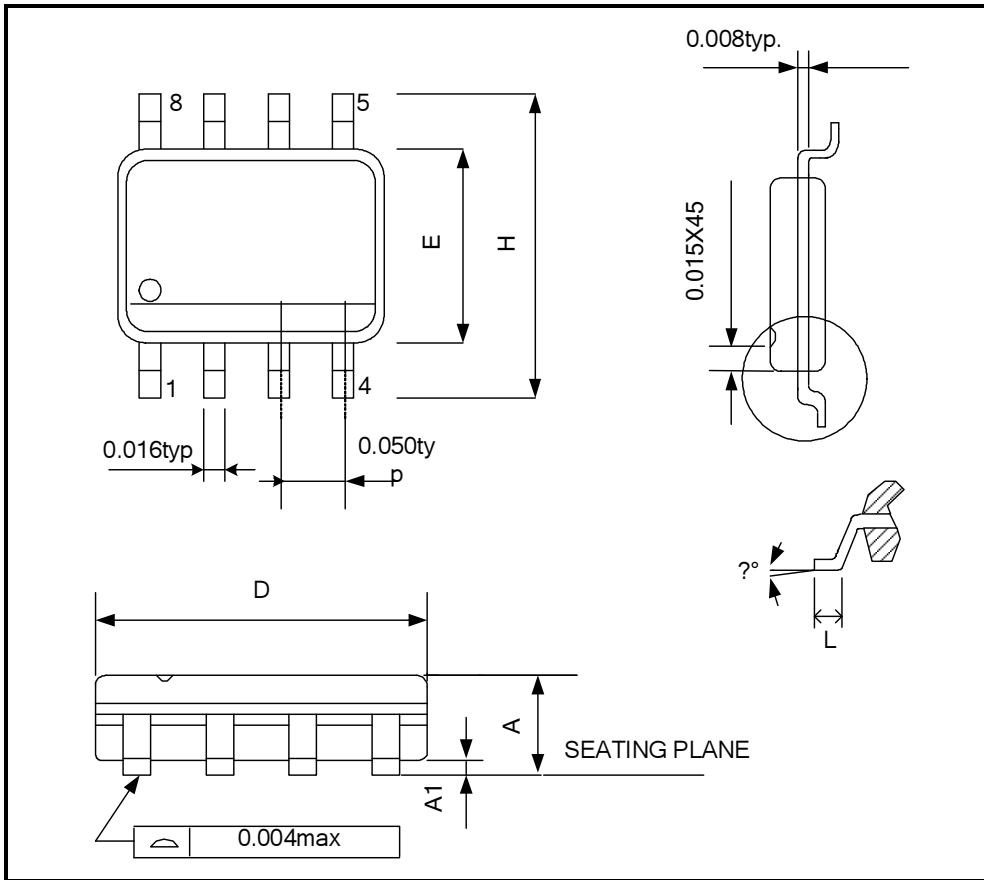

SYMBOLS	MIN	MAX
A	0.053	0.069
A1	0.004	0.010
A2	-	0.059
D	0.189	0.196
E	0.150	0.157
H	0.228	0.244
L	0.016	0.050
$\theta^\circ$	0	8

UNIT:INCH

NOTE:

1. JEDEC OUTLINE:MS-012 AA ◦
2. DIMENSIONS “D” DOES NOT INCLUDE MOLD FLASH,PROTRUSIONS OR GATE BURRS.MOLD FLASH,PROTRUSIONS AND GATE BURRS SHALL NOT EXCEED .15mm (.006in) PER SIDE ◦
3. DIMENSIONS “E” DOES NOT INCLUDE INTER-LEAD FLASH,OR PROTRUSIONS INTER-LEAD FLASH AND PROTRUSIONS SHALL NOT EXCEED .25mm (.010in) PER SIDE ◦

PDIP 8

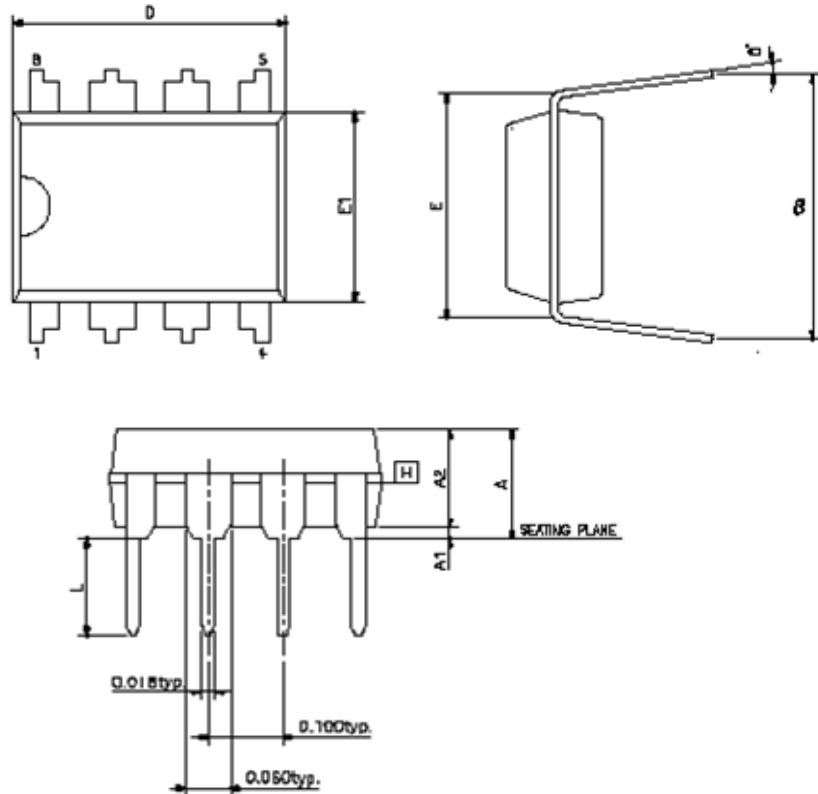

UNIT:INCH

SYMBOLS	MIN	NOR	MAX
A	-	-	0.210
A1	0.015	-	-
A2	0.125	0.130	0.135
D	0.355	0.365	0.400
E	0.300BSC.		
E1	0.245	0.250	0.255
L	0.115	0.130	0.150
$e_{\theta}$	0.335	0.355	0.375
$\theta^{\circ}$	0	7	15

Note:

1. JEDEC OUTLINE:MS-001 BA.
2. "D" 、"E1" DIMENSIONS DO NOT INCLUDE MOLD FLASH OR PROTRUSIONS SHALL NOT EXCEED .010 INCH.
3.  $e_{\theta}$  IS MEASURED AT THE LEAD TIPS WITH THE LEADS UNCONSTRAINED.
4. POINTED OR ROUNDED LEAD TIPS ARE PREFERRED TO EASE INSERTION.
5. DISTANCE BETWEEN LEADS INCLUDING DAM BAR PROTRUSIONS TO BE .005 INCH MINIMUM.
6. DATUM PLANE H COINCIDENT WITH THE BOTTOM OF LEAD, WHERE LEAD EXITS BODY.

**PACKING SPECIFICATIONS**

**BOX & CARTON DIMENSION**

**PDIP8**

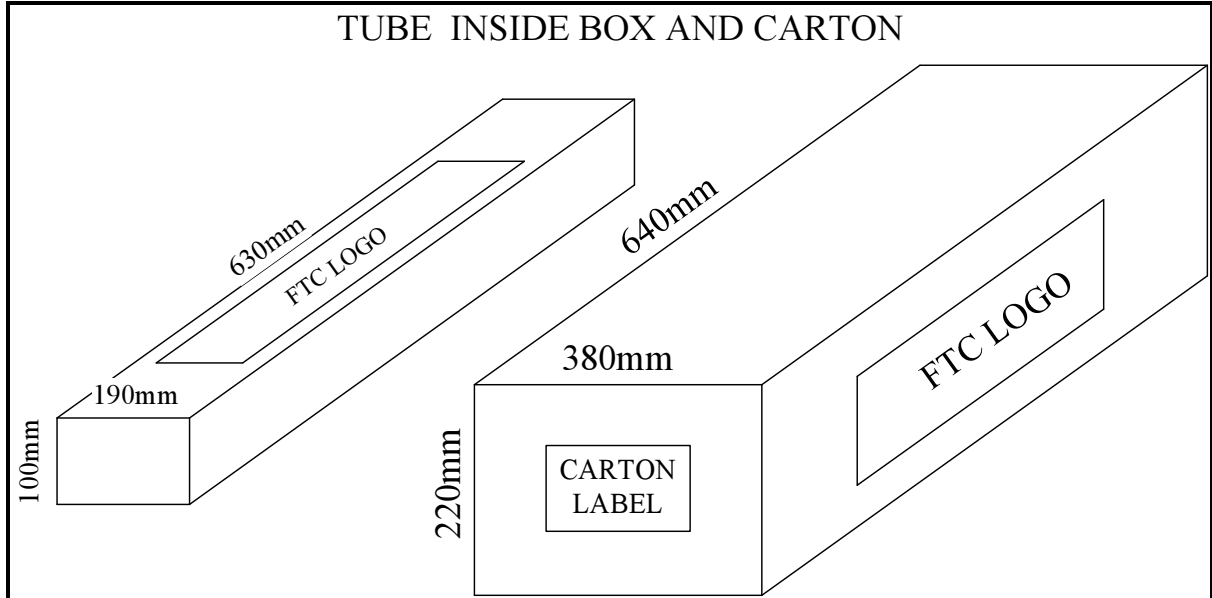

**SOP8**

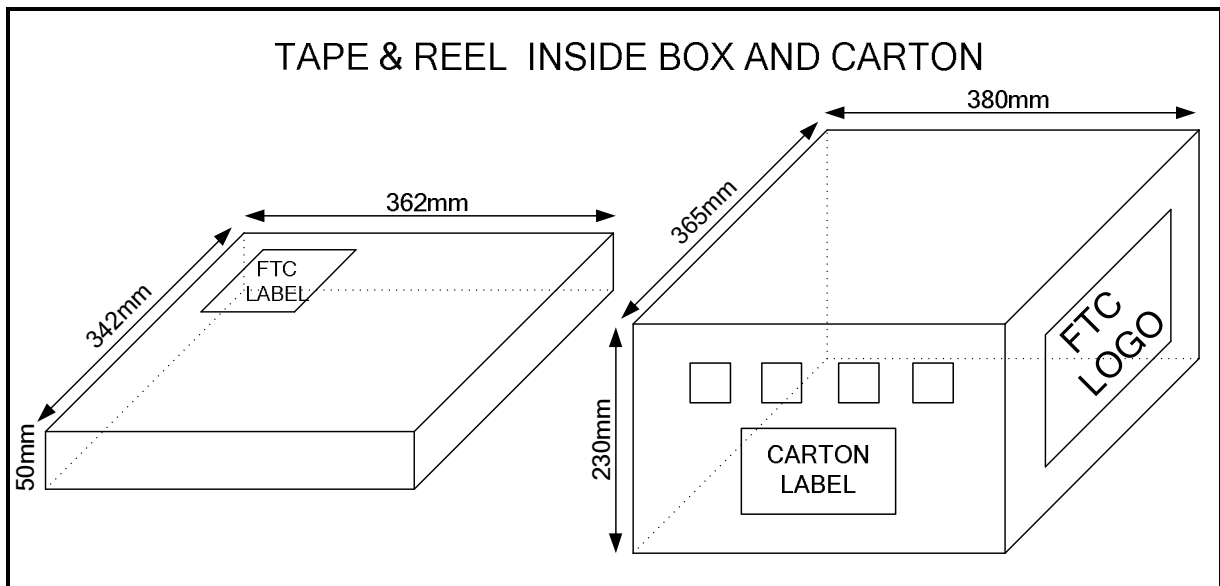

**PACKING QUANTITY SPECIFICATIONS**

SOP8	PDIP8
2500 EA / REEL	60 EA/TUBE
1 REELS / INSIDE BOX	60 TUBES / INSIDE BOX
4 INSIDE BOXES / CARTON	4 INSIDE BOXES / CARTON

**LABEL SPECIFICATIONS**

**TAPPING & REEL**

<p>Feeling Technology Corp          Product:FP6182DR-LF          Lot NO: XXXXXXXX          D/C: 8Xx-XXL          Q`ty: 2500</p>	<div style="border: 1px solid black; padding: 5px; display: inline-block;">             無鉛 Lead Free         </div>
---	---

**CARTON**

<p>Feeling Technology Corp          Product Type: FP6182DR-LF          Lot No: XXXXXXXX          Date Code: 8Xx-XXL          Package Type:SOP8          Marking Type:Laser          Total Q`ty: 10,000</p>	<div style="border: 1px solid black; padding: 5px; display: inline-block;">             無鉛 Lead Free         </div>
--	---

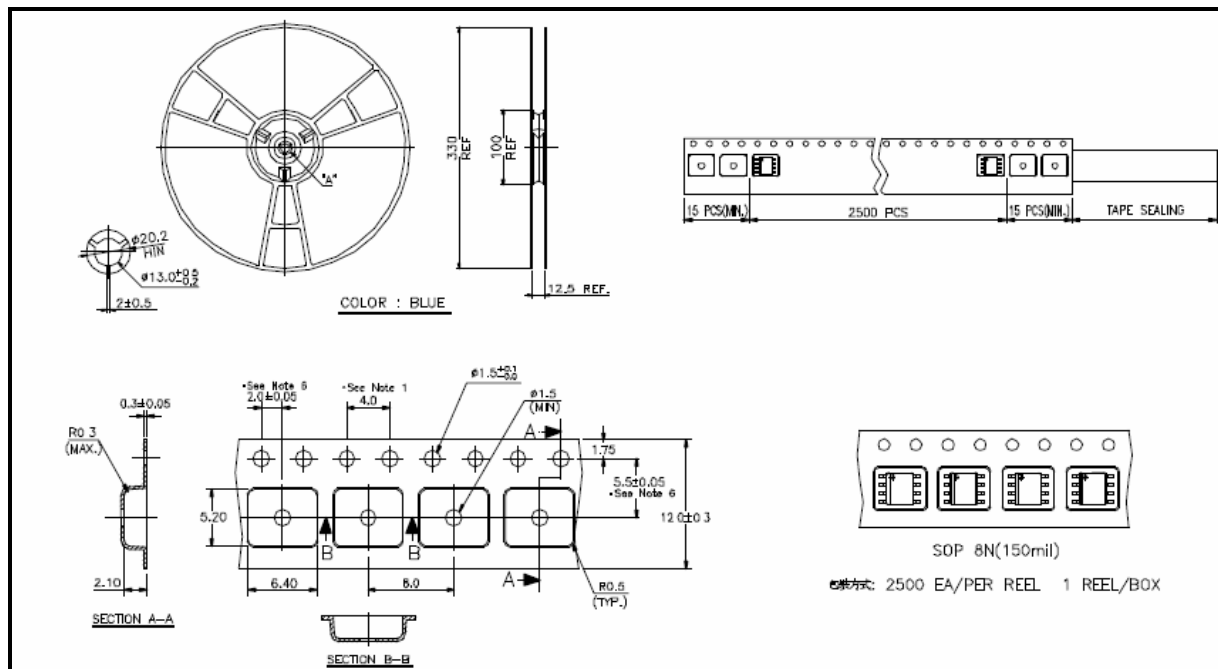
**CARRIER TAPE AND REEL DIMENSIONS**
**SOP8**

**Note:**

1. 10 SPROCKET HOLE PITCH CUMULATIVE TOLERANCE  $\pm 0.2$ mm.
2. COMBER NOT TO EXCEED 1mm IN 100mm.
3. MATERIAL : ANTI-STATIC BLOCK ADVANTEK POLYSTYRENE.
4.  $A_0$  AND  $B_0$  MEASURED ON A PLANE 0.3mm ABOVE THE BOTTOM OF THE POCKET.
5.  $K_0$  MEASURED FROM A PLANE AN THE INSIDE BOTTOM OF THE POCKET TO THE TOP SURFACE OF THE CARRIER.
6. POCKET POSITION RELATIVE TO SPROCKET HOLE MEASURED AS TRUE POSITION OF POCKET , NOT POCKET HOLE.

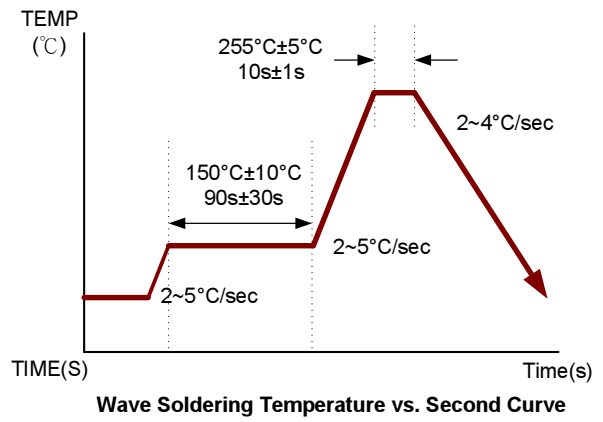
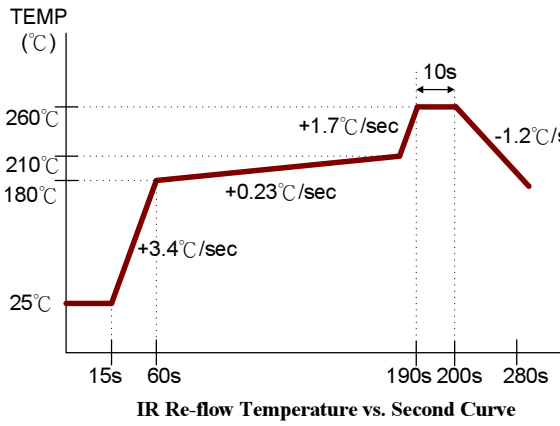
**SOLDER PROFILE**



**Note:**

1. Suggest IR Reflow Soldering Profile Condition.