

1 changed from 0.33uF  
The calculated value is 0.3uF  
but may need to be increased

2 A faster diode is used  
(better reverse recovery time)

3 8 only populate if  
winding 7-8 is not proved by UL  
for creepage distance issue  
of that transformer

4 11 MOSFET is changed to  
a faster turn-off one.  
A RCD Snubber is designed  
to decrease the switch turn-off  
loss and ringing, and the resistor  
value need to be tested.

5 7 A decoupling cap is included

6 9 A faster diode is included to speed up turn-off

10 A RC snubber is used to limit the voltage overshoot  
caused by leakage inductance resonance with parasitic capacitances  
Also a diode-transil clamp footprints are left for comparison.  
(diode-transil may dissipate more power at full load, but costs no power at no load)

12 Current sense resistor values are increased,  
because for a new transformer operates  
at higher duty cycle, the peak current  
will be smaller and needs to be limited

13 A Schottcky diode is used

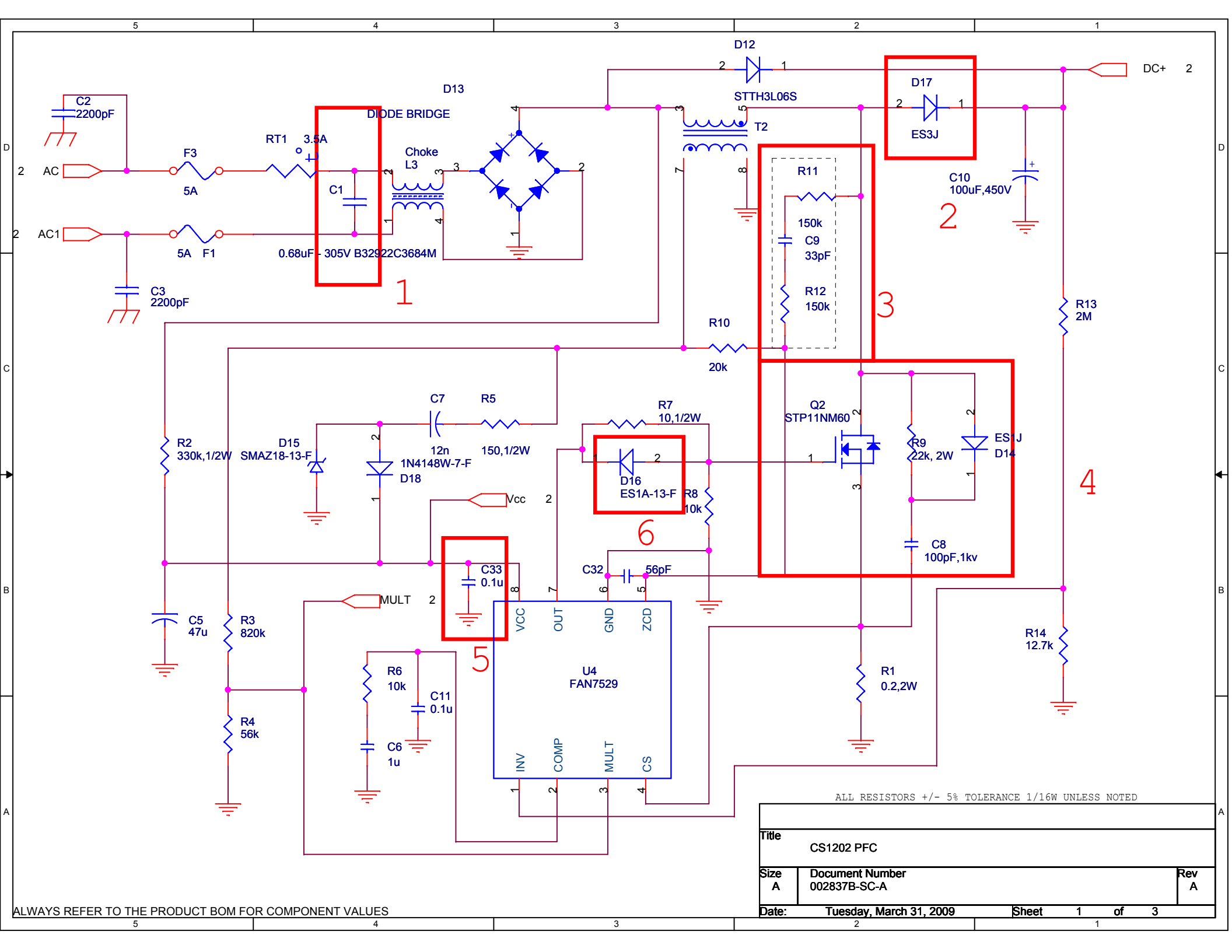

ALL RESISTORS +/- 5% TOLERANCE 1/16W UNLESS NOTED

Title		
CS1202 PFC		
Size	Document Number	Rev
A	002837B-SC-A	A
Date:	Tuesday, March 31, 2009	Sheet 1 of 3

ALWAYS REFER TO THE PRODUCT BOM FOR COMPONENT VALUES

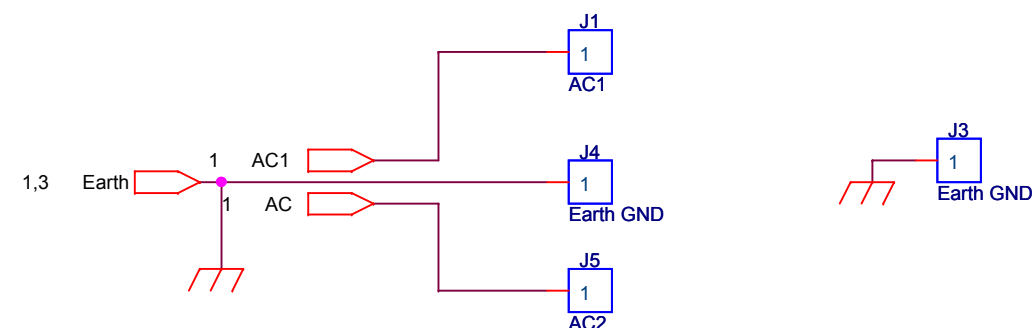
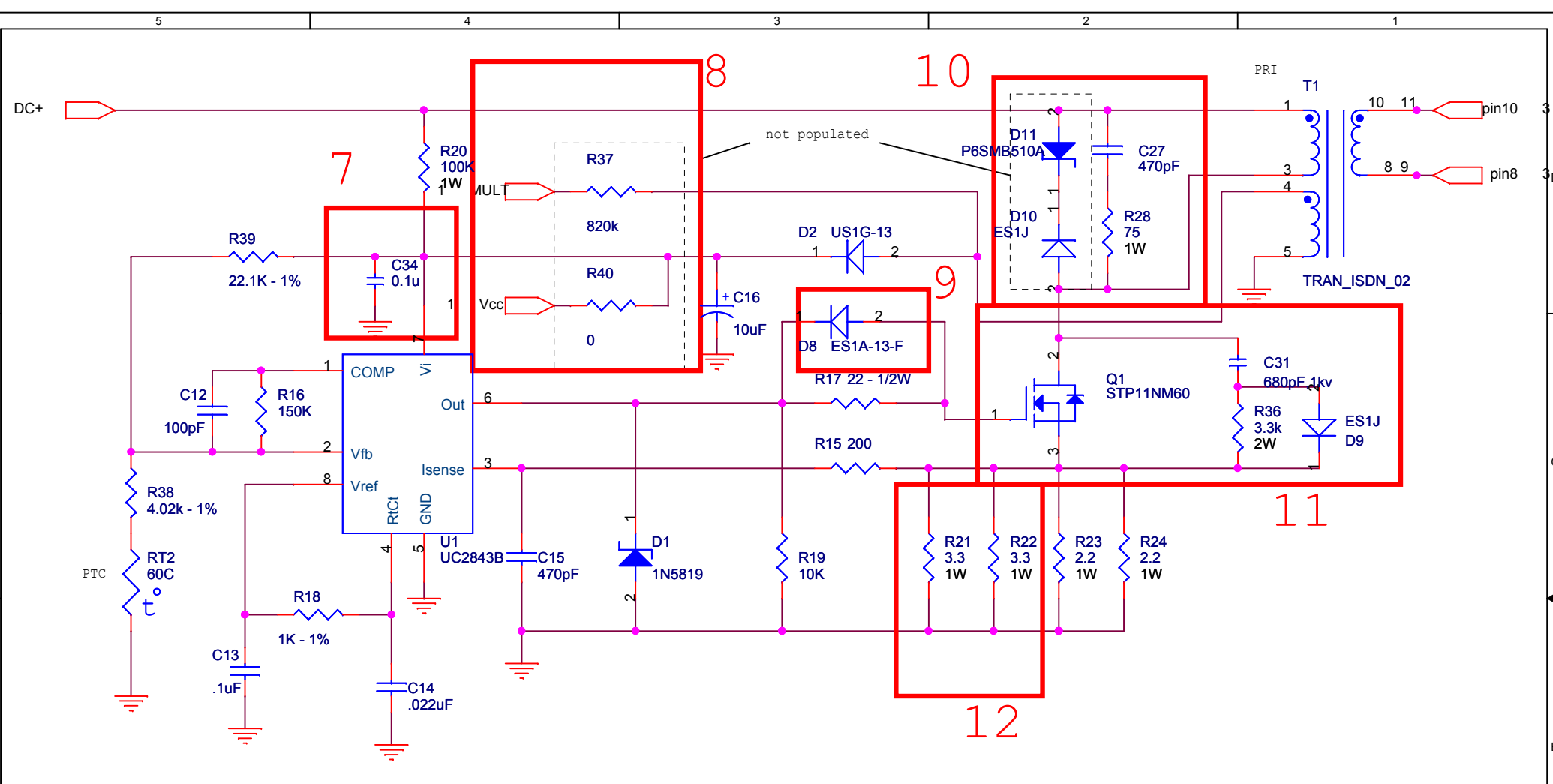

ALL RESISTORS +/- 5% TOLERANCE 1/16W UNLESS NOTED

Title		
CS1202 PFC		
Size	Document Number	Rev
A	002837B-SC-A	A
Date:	Monday, March 30, 2009	Sheet 2 of 3

ALWAYS REFER TO THE PRODUCT BOM FOR COMPONENT VALUES

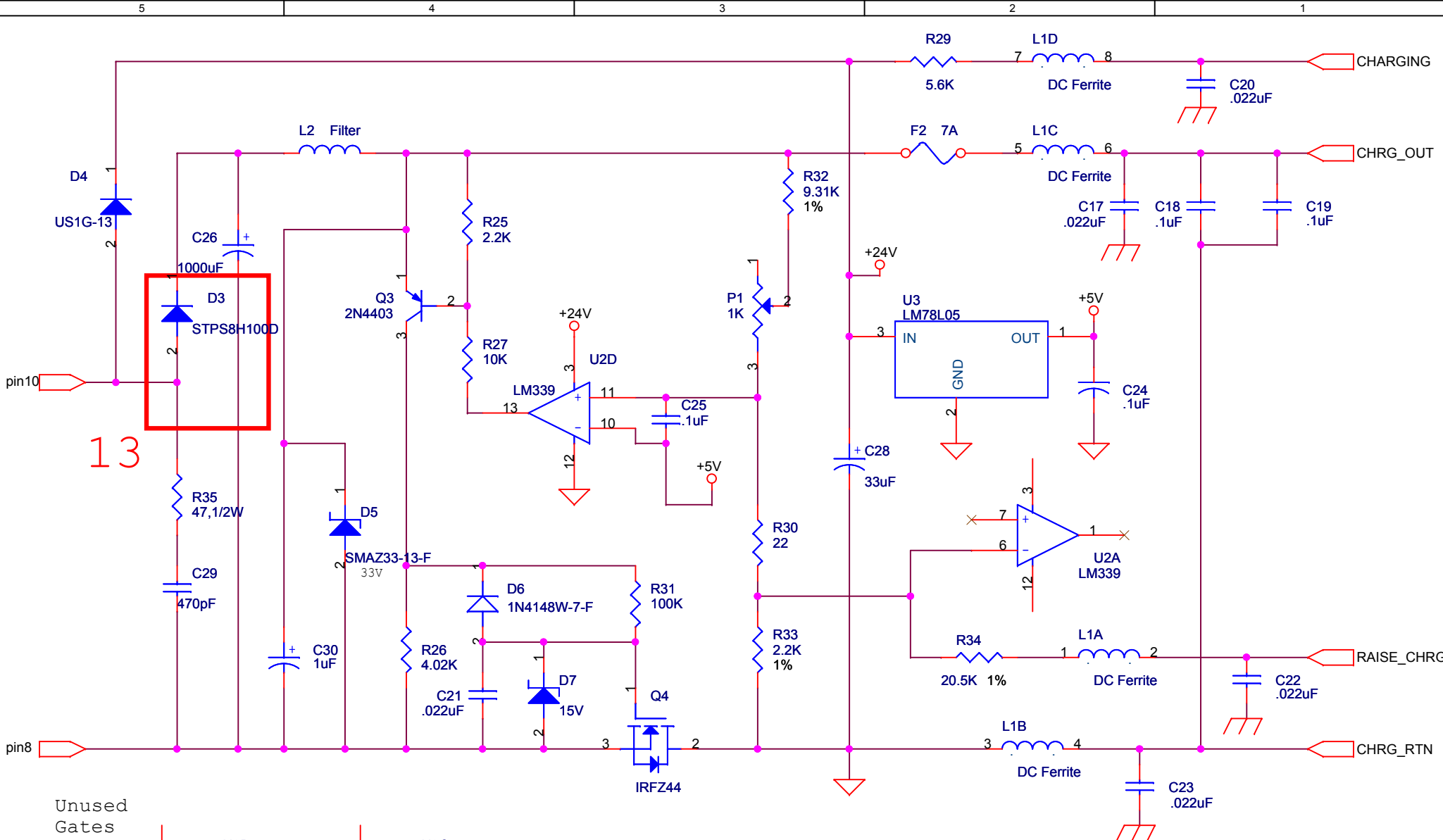

13

Unused Gates

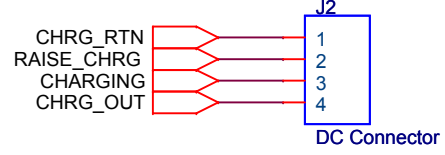
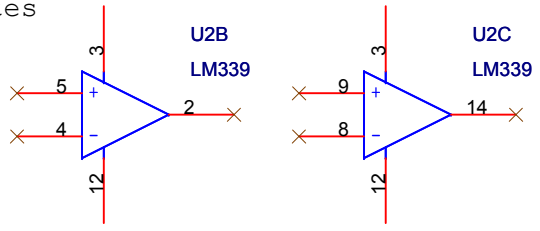

ALL RESISTORS +/- 5% TOLERANCE 1/16W UNLESS NOTED

ALWAYS REFER TO THE PRODUCT BOM FOR COMPONENT VALUES

Title		
CS1202 PFC		
Size	Document Number	Rev
A	002837B-SC-A	A
Date:	Tuesday, March 17, 2009	Sheet 3 of 3