

# UL 50E

## Enclosures for Electrical Equipment, Environmental Considerations

***UL COPYRIGHTED MATERIAL –  
NOT AUTHORIZED FOR FURTHER REPRODUCTION OR  
DISTRIBUTION WITHOUT PERMISSION FROM UL***

Underwriters Laboratories Inc. (UL)  
333 Pfingsten Road  
Northbrook, IL 60062-2096

UL Standard for Safety for Enclosures for Electrical Equipment, Environmental Considerations, UL 50E

First Edition, Dated September 4, 2007

### **Summary of Topics**

***This first edition of ANSI/UL 50E is the result of the harmonization effort to develop a tri-national standard covering requirements for enclosures for electrical equipment. The first edition of UL 50E contains the additional construction, performance, and marking requirements related to the environmental type rating designations. The non-environmental construction, performance, and marking requirements for enclosures are included in the twelfth edition of UL 50.***

The new requirements are substantially in accordance with UL's Proposal(s) on this subject dated March 11, 2005 and August 25, 2006.

As indicated on the title page (page 1), this UL Standard for Safety is an American National Standard. Attention is directed to the note on the title page of this Standard outlining the procedures to be followed to retain the approved text of this ANSI/UL Standard.

The UL Foreword is no longer located within the UL Standard. For information concerning the use and application of the requirements contained in this Standard, the current version of the UL Foreword is located on ULStandardsInfoNet at: <http://ulstandardsinfo.net/ulforeword.html>

The master for this Standard at UL's Northbrook Office is the official document insofar as it relates to a UL service and the compliance of a product with respect to the requirements for that product and service, or if there are questions regarding the accuracy of this Standard.

UL's Standards for Safety are copyrighted by UL. Neither a printed copy of a Standard, nor the distribution diskette for a Standard-on-Diskette and the file for the Standard on the distribution diskette should be altered in any way. All of UL's Standards and all copyrights, ownerships, and rights regarding those Standards shall remain the sole and exclusive property of UL.

All rights reserved. No part of this publication may be reproduced, stored in a retrieval system, or transmitted in any form by any means, electronic, mechanical photocopying, recording, or otherwise without prior permission of UL.

Revisions of UL Standards for Safety are issued from time to time. A UL Standard for Safety is current only if it incorporates the most recently adopted revisions.

UL provides this Standard "as is" without warranty of any kind, either expressed or implied, including but not limited to, the implied warranties of merchantability or fitness for any purpose.

In no event will UL be liable for any special, incidental, consequential, indirect or similar damages, including loss of profits, lost savings, loss of data, or any other damages arising out of the use of or the inability to use this Standard, even if UL or an authorized UL representative has been advised of the possibility of such damage. In no event shall UL's liability for any damage ever exceed the price paid for this Standard, regardless of the form of the claim.

***UL COPYRIGHTED MATERIAL –  
NOT AUTHORIZED FOR FURTHER REPRODUCTION OR  
DISTRIBUTION WITHOUT PERMISSION FROM UL***

UL will attempt to answer support requests concerning electronic versions of its Standards. However, this support service is offered on a reasonable efforts basis only, and UL may not be able to resolve every support request. UL supports the electronic versions of its Standards only if they are used under the conditions and operating systems for which it is intended. UL’s support policies may change from time-to-time without notification.

UL reserves the right to change the format, presentation, file types and formats, delivery methods and formats, and the like of both its printed and electronic Standards without prior notice.

Purchasers of the electronic versions of UL’s Standards for Safety agree to defend, indemnify, and hold UL harmless from and against any loss, expense, liability, damage, claim, or judgement (including reasonable attorney’s fees) resulting from any error or deviation introduced while purchaser is storing an electronic Standard on the purchaser’s computer system.

If a single-user version electronic Standard was purchased, one copy of this Standard may be stored on the hard disk of a single personal computer, or on a single LAN file-server or the permanent storage device of a multiple-user computer in such a manner that this Standard may only be accessed by one user at a time and for which there is no possibility of multiple concurrent access.

If a multiple-user version electronic Standard was purchased, one copy of the Standard may be stored on a single LAN file-server, or on the permanent storage device of a multiple-user computer, or on an Intranet server. The number of concurrent users shall not exceed the number of users authorized.

Electronic Standards are intended for on-line use, such as for viewing the requirements of a Standard, conducting a word search, and the like. Only one copy of the Standard may be printed from each single-user version of an electronic Standard. Only one copy of the Standard may be printed for each authorized user of a multiple-user version of an electronic Standard. Because of differences in the computer/software/printer setup used by UL and those of electronic Standards purchasers, the printed copy obtained by a purchaser may not look exactly like the on-line screen view or the printed Standard.

An employee of an organization purchasing a UL Standard can make a copy of the page or pages being viewed for their own fair and/or practical internal use.

The requirements in this Standard are now in effect, except for those paragraphs, sections, tables, figures, and/or other elements of the Standard having future effective dates as indicated in the preface. The prior text for requirements that have been revised and that have a future effective date are located after the Standard, and are preceded by a "SUPERSEDED REQUIREMENTS" notice.

New product submittals made prior to a specified future effective date will be judged under all of the requirements in this Standard including those requirements with a specified future effective date, unless the applicant specifically requests that the product be judged under the current requirements. However, if the applicant elects this option, it should be noted that compliance with all the requirements in this Standard will be required as a condition of continued Listing, Recognition, Classification, and Follow-Up Services after the effective date, and understanding of this should be signified in writing.

Copyright © 2007 Underwriters Laboratories Inc.

This Standard consists of pages dated as shown in the following checklist:

Page	Date
1-46.....	September 4, 2007

**UL COPYRIGHTED MATERIAL –  
NOT AUTHORIZED FOR FURTHER REPRODUCTION OR  
DISTRIBUTION WITHOUT PERMISSION FROM UL**



Association of Standardization and Certification  
NMX-J-235/2-ANCE-2007  
Second Edition



Canadian Standards Association  
CSA C22.2 No. 94.2-07  
First Edition



Underwriters Laboratories Inc.  
UL 50E  
First Edition

## Enclosures for Electrical Equipment, Environmental Considerations

September 4, 2007



ANSI/UL 50E-2007

*UL COPYRIGHTED MATERIAL –  
NOT AUTHORIZED FOR FURTHER REPRODUCTION OR  
DISTRIBUTION WITHOUT PERMISSION FROM UL*

## **Commitment for Amendments**

This standard is issued jointly by the Association of Standardization and Certification (ANCE), the Canadian Standards Association (CSA), and Underwriters Laboratories Inc. (UL). Comments or proposals for revisions on any part of the standard may be submitted to ANCE, CSA, or UL at any time. Revisions to this standard will be made only after processing according to the standards development procedures of ANCE, CSA, and UL. CSA and UL will issue revisions to this standard by means of a new edition or revised or additional pages bearing their date of issue. ANCE will incorporate the same revisions into a new edition of the standard bearing the same date of issue as the CSA and UL pages.

---

## **Copyright © 2007 ANCE**

Rights reserved in favor of ANCE.

---

**ISBN 1-55397-628-2**

**© 2007**

**Canadian Standards Association**

All rights reserved. No part of this publication may be reproduced in any form whatsoever without the prior permission of the publisher.

To purchase CSA Standards and related publications, visit CSA's Online Store at **[www.ShopCSA.ca](http://www.ShopCSA.ca)** or call toll-free 1-800-463-6727 or 416-747-4044.

---

## **Copyright © 2007 Underwriters Laboratories Inc.**

Revisions of this Standard will be made by issuing revised or additional pages bearing their date of issue. A UL Standard is current only if it incorporates the most recently adopted revisions, all of which are itemized on the transmittal notice that accompanies the latest set of revised requirements. Comments or proposals for revisions on any part of the Standard may be submitted to UL at any time. Proposals should be submitted via a Proposal Request in UL's On-Line Collaborative Standards Development System (CSDS) at <http://csds.ul.com>.

The most recent designation of ANSI/UL 50E as an American National Standard (ANSI) occurred on September 4, 2007.

This ANSI/UL Standard for Safety, which consists of the First Edition, is under continuous maintenance, whereby each revision is ANSI approved upon publication.

To purchase UL Standards, visit COMM 2000 at [http://www.comm-2000.com/help/how\\_to\\_order.aspx](http://www.comm-2000.com/help/how_to_order.aspx) or call toll free 1-888-853-3503.

---

***UL COPYRIGHTED MATERIAL –  
NOT AUTHORIZED FOR FURTHER REPRODUCTION OR  
DISTRIBUTION WITHOUT PERMISSION FROM UL***

**CONTENTS**

**Preface** .....5

1 Scope .....7

2 Units of Measurement .....7

3 Components .....7

4 Normative References .....8

5 Definitions .....8

6 Enclosure Types and Applications .....10

7 Construction .....10

    7.1 Polymeric materials .....10

    7.2 Corrosion protection .....11

    7.3 Openings .....14

    7.4 Conduit connection .....15

    7.5 External operating mechanisms .....15

    7.6 Access to interior .....16

    7.7 Gaskets .....16

8 Tests .....16

    8.1 General .....16

    8.2 Drip test .....17

    8.3 Rain test .....17

    8.4 Dust test .....18

    8.5 External icing test .....20

    8.6 Hosedown test .....21

    8.7 Indoor corrosion protection .....21

    8.8 Outdoor corrosion protection .....23

    8.9 Additional corrosion protection for type 4X and 6P .....24

    8.10 Submersion test .....25

    8.11 Pressure test .....25

    8.12 Oil exclusion test .....26

    8.13 Gasket tests .....26

    8.14 Rod entry test .....28

    8.15 Misalignment test .....28

    8.16 Water exposure and immersion .....29

9 Marking .....29

    9.1 General .....29

    9.2 Type designations .....29

    9.3 Supplemental markings .....29

    9.4 Location .....30

    9.5 Orientation .....30

    9.6 Equipment openings .....30

    9.7 Drainage openings .....30

Tables .....31

Figures .....35

**Annex A – Standards For Components (Normative)****Annex B – Reference Standards (Normative)****Annex C – Permanence Of Marking (Normative In The United States Only)****Annex D – Water Immersion Test (Normative)**

D.1 Water Exposure and Immersion .....	.44
D.1.1 General .....	.44
D.1.2 Dimensional change .....	.44
D.1.3 Water exposure and immersion test .....	.45



## Preface

This is the common ANCE, CSA, and UL standard for Enclosures for Electrical Equipment, Environmental Considerations. It is the second edition of NMX-J-235/2-ANCE-2007, the first edition of CSA C22.2 No. 94.2-07, and the first edition of UL 50E.

This common standard was prepared by the Association of Standardization and Certification (ANCE), the Canadian Standards Association (CSA), and Underwriters Laboratories Inc. (UL). The efforts and support of Technical Harmonization Committee 70/31 are gratefully acknowledged.

This standard is considered suitable for use for conformity assessment within the stated scope of the standard.

The present Mexican standard was developed by the CT CDI Control y Distribución Industrial from the Comité de Normalización de la Asociación de Normalización y Certificación, A.C., CONANCE, with the collaboration of the enclosures manufacturers and users.

This standard was reviewed by the CSA Subcommittee on Enclosures, under the jurisdiction of the CSA Technical Committee on Industrial Products and the CSA Strategic Steering Committee on Requirements for Electrical Safety, and has been formally approved by the CSA Technical Committee.

This standard will be submitted to the Standards Council of Canada (SCC) for approval as a National Standard of Canada.

This standard has been approved by the American National Standards Institute (ANSI) as an American National Standard.

Where reference is made to a specific number of samples to be tested, the specified number shall be considered a minimum quantity.

*Note: Although the intended primary application of this standard is stated in its scope, it is important to note that it remains the responsibility of the users of the standard to judge its suitability for their particular purpose.*

### Level of harmonization

This standard uses the IEC format but is not based on, nor shall it be considered equivalent to, an IEC standard. This standard is published as an equivalent standard for ANCE, CSA, and UL.

An equivalent standard is a standard that is substantially the same in technical content, except as follows: Technical national differences are allowed for codes and governmental regulations as well as those recognized as being in accordance with NAFTA Article 905, for example, because of fundamental climatic, geographical, technological, or infrastructural factors, scientific justification, or the level of protection that the country considers appropriate. Presentation is word for word except for editorial changes.

### Interpretations

The interpretation by the standards development organization of an identical or equivalent standard is based on the literal text to determine compliance with the standard in accordance with the procedural rules of the standards development organization. If more than one interpretation of the literal text has been identified, a revision is to be proposed as soon as possible to each of the standards development organizations to more accurately reflect the intent.

**UL COPYRIGHTED MATERIAL –  
NOT AUTHORIZED FOR FURTHER REPRODUCTION OR  
DISTRIBUTION WITHOUT PERMISSION FROM UL**

**ANCE effective date**

The effective date for ANCE will be announced through the Diario Oficial de la Federación (Official Gazette) and is indicated on the cover page.

**CSA effective date**

The effective date for CSA International will be announced through CSA Informs or a CSA certification notice.

**UL effective date**

As of September 4, 2007 all products Listed or Recognized by UL must comply with the requirements in this standard except for clauses, figures, and tables in the following list, which are effective September 4, 2012.

Clauses 7.3.3.1, 7.3.5.1, 7.4.2.3, 7.4.2.4, 7.6.1, 7.6.2, 7.7.1, 8.13.3.1 – 8.13.3.4, 8.14.1 – 8.14.2.1, 8.15.1 – 8.15.2.2, 9.2.3, Figure 3, and Tables 2 and 5

Between September 4, 2007 and September 4, 2012, new product submittals to UL may be evaluated under all requirements in this standard or, if requested in writing, evaluated under presently effective requirements only. The presently effective requirements are contained in the eleventh edition of UL 50.

A UL effective date is one established by Underwriters Laboratories Inc. and is not part of the ANSI approved standard.

# Enclosures for Electrical Equipment, Environmental Considerations

## 1 Scope

1.1 This standard applies to enclosures for electrical equipment intended to be installed and used in non-hazardous locations in accordance with the Canadian Electrical Code, Part I, CSA C22.1, the provisions of the National Electrical Code, NFPA 70, and the provisions of Mexico's Electrical Installations, NOM-001-SEDE, as follows:

- a) Enclosures for indoor locations, Types 1, 2, 5, 12, 12K, and 13; and
- b) Enclosures for indoor or outdoor locations, Types 3, 3R, 3S, 4, 4X, 6, and 6P.

1.2 This standard covers additional environmental construction and performance requirements for enclosures. The general requirements for enclosures are contained in standard CSA C22.2 No. 94.1, UL 50, and NMX-J-235/1-ANCE (See Annex B, Ref. No. 10) or the end-use product standards that are to be used in conjunction with this standard.

1.3 This standard does not cover the requirements for protection of devices against conditions such as condensation, icing, corrosion, or contamination that may occur within the enclosure or that may enter via conduit or unsealed openings.

1.4 Where an individual product standard contains requirements that are at variance with those of this standard, the requirements of the individual product standard take precedence.

## 2 Units of Measurement

2.1 The values given in SI (metric) units shall be normative. Any other values given shall be for informational purposes only.

## 3 Components

3.1 Except as indicated in 3.2, a component of a product covered by this standard shall comply with the requirements for that component. See Annex A for a list of standards covering components generally used in the products covered by this standard. A component shall comply with the ANCE, CSA, or UL standards as appropriate for the country where the product is to be used.

3.2 A component is not required to comply with a specific requirement that:

- a) Involves a feature or characteristic not required in the application of the component in the product covered by this standard, or
- b) Is superseded by a requirement in this standard.

3.3 A component shall be used in accordance with its rating established for the intended conditions of use.

3.4 Specific components are incomplete in construction features or restricted in performance capabilities. Such components are intended for use only under limited conditions, such as certain temperatures not exceeding specified limits, and shall be used only under those specific conditions.

#### 4 Normative References

4.1 For undated references to standards, such reference shall be considered to refer to the latest edition and all revisions to that edition up to the time when this standard was approved. For dated references to standards, such reference shall be considered to refer to the dated edition and all revisions published up to the time the standard was approved.

4.2 In Canada, general requirements are as indicated in Annex B, Ref. No. 6.

#### 5 Definitions

5.1 The following definitions are applicable in this standard.

5.1.1 BOX – That portion of an enclosure not including the cover or door.

5.1.2 BREAKOUT – A portion of a wall of a cast or molded enclosure so fashioned, usually by the use of one or more rings of reduced thickness of the wall material, that the material within the outer perimeter of the ring to be removed may be readily broken away at the time of installation in order to provide an opening similar to that provided by a knockout.

5.1.3 COVER – An unhinged portion of an enclosure that covers an opening.

5.1.4 DEGREE OF PROTECTION – The extent of protection provided by an enclosure against access to parts which result in a risk of injury, ingress of foreign solid objects, and/or ingress of water as verified by standardized test methods.

5.1.5 DESIGN TESTS – Tests to demonstrate performance of a product designed to applicable standards; they are not intended to be production tests.

5.1.6 DOOR – A hinged portion of an enclosure that covers an opening.

5.1.7 ENCLOSURE – A surrounding case constructed to provide a degree of protection to personnel against incidental contact with the enclosed equipment and to provide a degree of protection to the enclosed equipment against specified environmental conditions. The specific enclosure types, their applications, and the environmental conditions for which they are designed to protect against are as follows:

TYPE 1 – Enclosures constructed for indoor use to provide a degree of protection to personnel against incidental contact with the enclosed equipment and to provide a degree of protection against falling dirt.

TYPE 2 – Enclosures constructed for indoor use to provide a degree of protection to personnel against incidental contact with the enclosed equipment, to provide a degree of protection against falling dirt, and to provide a degree of protection against dripping and light splashing of non-corrosive liquids.

TYPE 3 – Enclosures constructed for either indoor or outdoor use to provide a degree of protection to personnel against incidental contact with the enclosed equipment; to provide a degree of protection against falling dirt, rain, sleet, snow, and windblown dust; and that will be undamaged by the external formation of ice on the enclosure.

TYPE 3R – Enclosures constructed for either indoor or outdoor use to provide a degree of protection to personnel against incidental contact with the enclosed equipment; to provide a degree of protection against falling dirt, rain, sleet, and snow; and that will be undamaged by the external formation of ice on the enclosure.

TYPE 3S – Enclosures constructed for either indoor or outdoor use to provide a degree of protection to personnel against incidental contact with the enclosed equipment; to provide a degree of protection against falling dirt, rain, sleet, snow, and windblown dust; and in which the external mechanism(s) remain operable when ice laden.

TYPE 4 – Enclosures constructed for either indoor or outdoor use to provide a degree of protection to personnel against incidental contact with the enclosed equipment; to provide a degree of protection against falling dirt, rain, sleet, snow, windblown dust, splashing water, and hose-directed water; and that will be undamaged by the external formation of ice on the enclosure.

TYPE 4X – Enclosures constructed for either indoor or outdoor use to provide a degree of protection to personnel against incidental contact with the enclosed equipment; to provide a degree of protection against falling dirt, rain, sleet, snow, windblown dust, splashing water, hose-directed water, and corrosion; and that will be undamaged by the external formation of ice on the enclosure.

TYPE 5 – Enclosures constructed for indoor use to provide a degree of protection to personnel against incidental contact with the enclosed equipment; to provide a degree of protection against falling dirt; against settling airborne dust, lint, fibers, and flyings; and to provide a degree of protection against dripping and light splashing of non-corrosive liquids.

TYPE 6 – Enclosures constructed for either indoor or outdoor use to provide a degree of protection to personnel against incidental contact with the enclosed equipment; to provide a degree of protection against falling dirt, rain, sleet, snow, hose-directed water, and the entry of water during occasional temporary submersion at a limited depth, and that will be undamaged by the external formation of ice on the enclosure.

TYPE 6P – Enclosures constructed for either indoor or outdoor use to provide a degree of protection to personnel against incidental contact with the enclosed equipment; to provide a degree of protection against falling dirt, rain, sleet, snow, hose-directed water, corrosion and the entry of water during prolonged submersion at a limited depth; and that will be undamaged by the external formation of ice on the enclosure.

TYPE 12 – Enclosures constructed (without knockouts) for indoor use to provide a degree of protection to personnel against incidental contact with the enclosed equipment; to provide a degree of protection against falling dirt, against circulating dust, lint, fibers, and flyings; against dripping and light splashing of non-corrosive liquids; and against light splashing and consequent seepage of oil and non-corrosive coolants.

***UL COPYRIGHTED MATERIAL –  
NOT AUTHORIZED FOR FURTHER REPRODUCTION OR  
DISTRIBUTION WITHOUT PERMISSION FROM UL***

TYPE 12K – Enclosures constructed (with knockouts) for indoor use to provide a degree of protection to personnel against incidental contact with the enclosed equipment; to provide a degree of protection against falling dirt, against circulating dust, lint, fibers, and flyings; against dripping and light splashing of non-corrosive liquids; and against light splashing and consequent seepage of oil and non-corrosive coolants.

TYPE 13 – Enclosures constructed for indoor use to provide a degree of protection to personnel against incidental contact with the enclosed equipment; to provide a degree of protection against falling dirt, against circulating dust, lint, fibers, and flyings; and against the spraying, splashing, and seepage of water, oil, and non-corrosive coolants.

5.1.8 INDOOR LOCATIONS – Areas that are protected from exposure to the weather.

5.1.9 KNOCKOUT – A portion of a wall of a sheet metal enclosure so fashioned that it may be removed readily by a hammer, screwdriver, and pliers at the time of installation in order to provide a hole for the attachment of an auxiliary device or raceway, cable, or fitting.

5.1.10 NONVENTILATED – Constructed so as to provide no intentional circulation of external air through the enclosure.

5.1.11 OIL RESISTANT GASKETS – Gaskets made of material that is resistant to oil and oil fumes.

5.1.12 OUTDOOR LOCATIONS – Areas that are exposed to the weather.

5.1.13 SCRIBING TOOL – A straight-shank tungsten carbide tip, lathe cutting tool, or carbide-tipped pencil type tool used to penetrate a protective coating on base metal.

5.1.14 THREADED CONDUIT ENTRY – A conduit entry that is threaded so as to secure a rigid conduit without the use of a bushing or locknut.

5.1.15 VENTILATED – Constructed so as to provide for the circulation of external air through the enclosure to remove excess heat, fumes, or vapors.

## 6 Enclosure Types and Applications

6.1 Protection against specific environmental conditions as defined for each environmental type (see 5.1.7) is applicable only when the enclosure is completely and properly installed.

6.2 All mechanical and electrical parts mounted on or through an enclosure shall pass the applicable tests for the enclosure type unless otherwise specified in the standard.

6.3 Table 1 indicates the environmental conditions that each enclosure type is tested for and aids in comparing applications for enclosure types.

## 7 Construction

### 7.1 Polymeric materials

7.1.1 Polymeric materials used for Types 3, 3R, 3S, 4, 4X, 6, and 6P enclosures or polymeric materials used for fastenings and/or hinges for these enclosure types shall comply with the Ultraviolet light exposure test (Weatherometer test) specified in Annex B, Ref. No. 1.

*UL COPYRIGHTED MATERIAL –  
NOT AUTHORIZED FOR FURTHER REPRODUCTION OR  
DISTRIBUTION WITHOUT PERMISSION FROM UL*

7.1.2 Polymeric materials used for Types 6 and 6P enclosures or polymeric materials used for fastenings and/or hinges for these enclosure types shall comply with the Water exposure and immersion tests specified in 8.16.

## **7.2 Corrosion protection**

### **7.2.1 General**

7.2.1.1 Enclosures made of the following materials shall be considered to comply with the indoor and outdoor corrosion requirements:

- a) Copper, aluminum, or stainless steel; and
- b) Bronze or brass containing at least 80 percent copper.

7.2.1.2 Enclosures shall not be constructed of metals in any combination such as to cause galvanic action that will adversely affect any part of the equipment exposed to moisture.

7.2.1.3 Fasteners and hinges used on an enclosure shall be resistant to corrosion and shall comply with the same requirements as the enclosure.

7.2.1.4 Other than as permitted by 7.2.1.5, both the inside and outside surfaces of an enclosure made of ferrous material, along with any external ferrous parts attached to these enclosures, shall be protected against corrosion in accordance with 7.2.2, 7.2.3, or 7.2.4.

7.2.1.5 The corrosion protection requirement does not apply to:

- a) Bearings, sliding surfaces of a hinge or shaft, and the like, located on the exterior of these enclosures;
- b) Sheared or cut edges and punched holes of galvanized sheet steel;
- c) Parts such as a decorative grill, and the like, that are not required to form part of these enclosures.

## 7.2.2 Indoor corrosion

7.2.2.1 Type 1, 2, 5, 12, 12K, and 13 ferrous enclosures and external ferrous parts attached to these enclosures either:

- a) Shall be protected against corrosion by enameling, painting, galvanizing, or other equivalent means; or
- b) Shall be tested in accordance with 8.7.

## 7.2.3 Outdoor corrosion

7.2.3.1 Type 3, 3R, 3S, 4, 4X, 6, and 6P ferrous enclosures, and external ferrous parts attached to these enclosures shall be protected against corrosion by one of the coatings in 7.2.3.1 (a) – (d) or shall comply with the test requirements of 8.8:

- a) Hot-dipped mill-galvanized sheet steel conforming with the coating Designation G90 in Table I of Annex B, Ref. No. 2;
- b) A zinc coating, other than that provided on hot-dipped mill-galvanized sheet steel, uniformly applied to an average thickness of not less than 0.015 mm (0.00061 inch) on each surface with a minimum thickness of 0.014 mm (0.00054 inch). The thickness of coating shall be established by the metallic-coating-thickness test described in Annex B, Ref. No. 3. An annealed coating shall comply with 7.2.3.2 and 7.2.3.3;
- c) A zinc coating conforming with 7.2.3.1(c)(1) or 7.2.3.1(c)(2) and with one coat of an organic finish of the epoxy or alkyd-resin type or other outdoor paint applied after forming on each surface. The acceptability of the paint may be determined by consideration of its composition or by corrosion tests if these are considered necessary;
  - 1) Hot-dipped mill-galvanized sheet steel conforming with the coating Designation G60 or A60 in Table I of Annex B, Ref. No. 2;
  - 2) A zinc coating, other than that provided on hot-dipped mill-galvanized sheet steel, uniformly applied to an average thickness of not less than 0.010 mm (0.00041 inch) on each surface with a minimum thickness of 0.009 mm (0.00034 inch). The thickness of the coating shall be established by the metallic-coating-thickness test described in Annex B, Ref. No. 3.
- d) Paint shall comply with the requirements in 8.8 or Annex B, Ref. No. 7;

7.2.3.2 An annealed coating on sheet steel that is bent or similarly formed or extruded or rolled at edges of holes after annealing shall be additionally painted in the affected area if the process damages the zinc coating. See 7.2.3.1(b).

7.2.3.3 If flaking or cracking of the zinc coating at the outside radius of the bent or formed section is visible at 25 power magnification, the zinc coating is considered to be damaged. Simple sheared or cut edges and punched holes are not required to be additionally protected. See 7.2.3.1(b) and 7.2.3.7.



7.2.3.4 A hot-dipped mill-galvanized G90 coating shall not be damaged during handling or fabrication to the extent that the base metal is exposed, other than as allowed by 7.2.3.5 and 7.2.3.6. See 7.2.3.1(a).

7.2.3.5 In accordance with 7.2.3.4, uncoated cross-sectional surfaces at cut edges and drilled openings are acceptable.

7.2.3.6 In accordance with 7.2.3.4, the base metal may be exposed if:

- a) The maximum width and length of the exposed metal does not exceed the thickness and length of any cut edge on the sheet; or
- b) The surface has one coat of an organic finish of the epoxy or alkyd-resin type, or other outdoor paint applied after fabrication.

7.2.3.7 Sheet steel that employs a hot-dipped mill-galvanized G90 coating that is drawn, formed, extruded, or rolled shall be additionally painted with one coat of an organic finish of the epoxy or alkyd-resin type or other outdoor paint in the areas that are affected by a process that damages the coating as determined by the requirement in 7.2.3.3. See 7.2.3.1(b).

7.2.3.8 An enclosure of cast iron or malleable iron at least 3.2 mm (1/8 inch) thick shall be protected against corrosion by:

- a) A 0.0038 mm (0.00015 inch) thick coating of zinc, cadmium, or the equivalent, on the outside surface and a visible coating of such metal on the inside surface; or
- b) One coat of an organic finish of the epoxy or alkyd-resin type or other outdoor paint on each surface. The acceptability of the paint may be determined by consideration of its composition or, if necessary, by Corrosion tests as specified in 8.8.

7.2.4 Additional corrosion protection

7.2.4.1 Type 4X and 6P enclosures, and external parts attached to these enclosures, shall be manufactured of American Iron and Steel Institute (AISI) Type 304 or Type 316 stainless steel, polymers, or other materials that have been determined to comply with 7.2.3 and 8.9.

## 7.3 Openings

### 7.3.1 General

7.3.1.1 Other than as permitted by 7.3.1.2, openings provided in an enclosure shall comply with the tests in Table 2 with these openings unfilled.

7.3.1.2 Openings in accordance with 7.3.2, if provided in the test enclosure, shall be filled as intended to maintain the environmental integrity of the enclosure.

7.3.1.3 Joints for all devices closing openings into the equipment cavity of a Type 12 or 12K enclosure, as well as any door or cover for a Type 12 or 12K enclosure, shall include a gasket in the full length of the joint. The gasket shall comply with the requirements of 8.13.

### 7.3.2 Equipment openings

7.3.2.1 Enclosures may be provided with openings that are intended to be closed by field-installed equipment (such as pushbutton switches, door latches, etc.) if these enclosures are marked in accordance with 9.6.

### 7.3.3 Drainage openings

7.3.3.1 Type 2 and 3R enclosures shall have provisions for drainage. Drainage openings shall not be less than 3.2 mm in diameter (1/8 inch in diameter) or more than 6.4 mm in diameter (1/4 inch in diameter), unless baffled or provided with a drainage fitting.

7.3.3.2 For Type 2 and 3R enclosures that also meet the requirements of other enclosure types, the drainage openings shall be closed by a removable plug, and instructions shall be provided in accordance with 9.7.1.

7.3.3.3 Type 2 and 3R enclosures that also meet the requirements of other enclosure types need not have drainage holes if the enclosure is provided with instructions in accordance with 9.7.2.

### 7.3.4 Mounting openings

7.3.4.1 For Type 3, 3S, 4, 4X, 6, 6P, 12, 12K, and 13 enclosures, the mounting means shall be external to the equipment cavity or shall comply with 7.3.4.2. For Type 1, 2, 3R and 5 enclosures, the mounting means shall comply with 6.3.4 of Annex B, Ref. No. 10.

7.3.4.2 In accordance with 7.3.4.1, the mounting means may pass through the enclosure wall into the equipment cavity if it attaches to an intermediate bracket or foot and is tested in accordance with 8.1. The bracket or foot shall then rely on separate mounting hardware to attach it to the building wall. The mounting means shall not have the same mounting hardware both pass through the equipment cavity and attach directly to the building wall.

7.3.4.3 The mounting means noted in 7.3.4.1 may be provided as a kit if the kit and the marking or instructions are included with the enclosure referencing this kit. The kit may be supplied separately only if the hardware required to maintain the environmental rating of the enclosure is provided.

### 7.3.5 Ventilation

7.3.5.1 Type 1, 2, and 3R enclosures may be ventilated.

## 7.4 Conduit connection

### 7.4.1 General

7.4.1.1 Enclosures shall be designed for use with appropriate conductor entry provisions to maintain the specified environmental capability in accordance with 8.1.1 after proper installation.

### 7.4.2 Hubs and fittings

7.4.2.1 An enclosure provided without conduit hubs shall be marked in accordance with 9.6.

7.4.2.2 A conduit hub or fitting may be shipped separately if the necessary hardware, gaskets, and instructions are provided with either the enclosure or the fitting.

7.4.2.3 For non-metallic enclosures, other than Type 1, designed for or equipped with detachable threaded conduit hubs that are held in a circular opening, such as a single breakout or knockout, pre-punched openings, or user-punched (as specified in the manufacturer's instructions) openings, by means of a locknut or equivalent, shall withstand a Misalignment test in accordance with the requirements of 8.15 applied to any detachable hub installed in the enclosure.

7.4.2.4 In Canada, the requirements of 7.4.2.3 shall also apply to metallic enclosures, other than Type 1, with wall thickness less than 1.35 mm (0.05 in).

### 7.4.3 Knockouts and breakouts

7.4.3.1 All enclosure types may have knockouts and breakouts, except Type 12 enclosures.

7.4.3.2 Knockouts and breakouts shall meet the appropriate design tests in Table 2 for the enclosure type in which they are provided.

## 7.5 External operating mechanisms

7.5.1 External operating mechanisms, when mounted on or through the enclosure, shall comply with the applicable design tests in Table 2 for the enclosure type unless otherwise specified.

7.5.2 External operating mechanisms on a Type 3S enclosure shall support the additional weight of ice and withstand the removal of ice by a hand tool. See 8.5.

## 7.6 Access to interior

7.6.1 Types 3, 3R, 3S, 5, 12, and 12K enclosures shall require the use of a tool to gain access to the equipment cavity or shall have provisions for locking. When the provision for locking is provided as an accessory:

- a) The accessory shall be shipped with the enclosure of which it is intended to be installed; and
- b) Both the accessory and the enclosure shall comply with clause 9.

7.6.2 All closing hardware for Type 5, 12, and 12K enclosures shall be captive.

## 7.7 Gaskets

7.7.1 A gasket of elastomeric or thermoplastic material or a composition gasket utilizing an elastomeric material that is provided on a Type 2, 3, 3R, 3S, 4, 4X, 5, 6, 6P, 12, 12K, or 13 enclosure to meet the environmental construction and performance requirements of this standard shall comply with the Gasket tests of 8.13.2 and 8.13.3.

7.7.2 A gasket provided on a Type 12, 12K, or 13 enclosure shall be oil resistant and shall additionally comply with the Oil immersion test in 8.13.4.

7.7.3 A gasket shall be secured with adhesive or by mechanical means. The gasket and its securing means shall not be damaged when the joint is opened.

## 8 Tests

### 8.1 General

8.1.1 The following design tests shall be used to demonstrate conformance with this standard. The enclosure and its enclosed equipment shall be mounted (including all mounting options) as intended for use in service.

8.1.2 Each enclosure type shall be evaluated to the specific design tests as outlined in Table 2.

## 8.2 Drip test

### 8.2.1 Method A

8.2.1.1 The enclosure shall be mounted beneath a drip test apparatus that extends beyond all exposed sides of the enclosure. The drip test apparatus shall be equipped with uniformly distributed drip sources. There shall be one drip source for each 129 cm<sup>2</sup> (20 in<sup>2</sup>) of test surface area and each drip source shall have a drip rate of at least 20 drops of water per minute. The enclosure shall be subjected to continuously dripping water for 30 minutes. Conduit shall be connected as intended.

### 8.2.2 Method B

8.2.2.1 The enclosure with conduit connected shall be mounted as intended and the top exposed to a water spray falling for 1 hour at the rate of 25 ±10 mm/h (1 ±3/8-in/h), at any angle up to 15 degrees from the vertical.

8.2.2.2 A Type 2 enclosure shall be considered to have met the requirements if at the conclusion of the test:

- a) There is no accumulation of water within the enclosure; and
- b) No water has entered the enclosure at a level higher than the lowest live part, other than as permitted by 8.2.2.3.

8.2.2.3 In accordance with 8.2.2.2, water may enter above live parts in an enclosure that complies with 9.5.3 if the equipment is so constructed that no water is visible on the live parts, insulating material, or mechanism parts, and no water has entered any space within the enclosure in which wiring may be present under any proper installation conditions.

## 8.3 Rain test

8.3.1 A complete enclosure with conduit connected shall be mounted as in actual service, except that the conduit shall be connected without using pipe thread sealing compound. Rigid conduit shall be threaded into the opening in the enclosure and tightened with torques specified in Table 3.

8.3.2 The test apparatus shall consist of at least three spray heads mounted in a water supply pipe rack as shown in Figure 1. Spray heads shall be constructed in accordance with the details shown in Figure 2.

8.3.3 The enclosure shall be positioned in the focal area of the spray heads so that the greatest quantity of water is likely to enter the enclosure. The water pressure shall be maintained at 34.5 kPa (5 psi) at each spray head and a continuous water spray shall be applied for one hour.

8.3.4 A Type 3R enclosure shall be considered to have met the requirements if at the conclusion of the test:

- a) There is no accumulation of water within the enclosure; and
- b) No water has entered the enclosure at a level higher than the lowest live part, other than as permitted by 8.3.5.

8.3.5 Water may enter above live parts in an enclosure that complies with 9.5.3 if the equipment is so constructed that no water is visible on the live parts, insulating material, or mechanism parts, and no water has entered any space within the enclosure in which wiring may be present under any proper installation conditions.

## **8.4 Dust test**

### **8.4.1 Outdoor dust test**

#### **8.4.1.1 Dust blast method**

8.4.1.1.1 The enclosure shall be subjected to a blast of compressed air mixed with dry Type 1 general-purpose Portland cement (see Table 4), using a suction-type sand blast gun that is equipped with a 4.7 mm diameter (3/16 inch diameter) air jet and a 9.5 mm diameter (3/8 inch diameter) nozzle. The air shall be dry and at a pressure of 620 – 690 kPa (90 – 100 pounds per square inch). The cement shall be applied at a rate of 2.27 kg per minute (5 pounds per minute). The nozzle shall be held 305 – 380 mm (12 – 15 inches) away from the enclosure, and the blast of air and cement shall be directed at all points of potential dust entry, such as seams, joints, and external operating mechanisms. The total volume of cement sprayed shall be at least 5.9 kg per linear meter of test length (4 pounds per linear foot of test length). The test length shall be equal to the sum of the height, width, and depth of the test specimen. A conduit may be installed to equalize the internal and external pressures.

8.4.1.1.2 The enclosure shall be considered to have met the requirements if at the conclusion of the test no dust has entered the enclosure.

#### **8.4.1.2 Hose method**

8.4.1.2.1 The enclosure and its external mechanisms shall be subjected to a stream of water from a hose that has a 25 mm inside diameter (1 inch inside diameter) nozzle that delivers at least 170 L per minute (45 gallons per minute). The water shall be directed at all joints from a distance of 3.0 – 3.5 m (10 – 12 feet). The nozzle shall be moved along each joint one time at a uniform nominal rate of 6 mm/s (1/4 inch per second). A conduit may be installed to equalize internal and external pressures, but shall not serve as a drain.

8.4.1.2.2 The enclosure shall be considered to have met the requirements if at the conclusion of the test no water has entered the enclosure.

## 8.4.2 Indoor dust test

### 8.4.2.1 Circulating dust test

#### 8.4.2.1.1 Dust method

8.4.2.1.1.1 The enclosure shall be placed in its intended mounting position in an airtight chamber having an internal volume not less than 0.169 m<sup>3</sup> (6 cubic feet). The volume of the chamber shall be not less than 150 percent of the volume of the enclosure under test (L x W x H). The test chamber shall be maintained at ambient room temperature and 20 – 50 percent relative humidity.

8.4.2.1.1.2 At least 1.5 kilograms (1.5 ounce per cubic foot) of dry Type 1 general-purpose Portland cement (see Table 4) per cubic meter of test chamber shall be circulated by means of a blower suction unit for 5 minutes so as to completely envelop the enclosure under test. The air velocity at the outlet of the blower shall be maintained at approximately 305 meters per minute (1000 feet per minute).

8.4.2.1.1.3 The enclosure shall be considered to have met the requirements if at the conclusion of the test no dust has entered the enclosure.

#### 8.4.2.1.2 Atomized-water method (Method A)

8.4.2.1.2.1 The enclosure shall be subjected to a spray of atomized water using a nozzle that produces a round pattern 75 – 100 mm in diameter when measured 300 mm from the nozzle (3 – 4 inches in diameter when measured 12 inches from the nozzle). The air pressure shall be 200 kPa (30 psi). Not less than 4.8 mL/linear cm (5 ounce per linear foot) shall be applied at a rate of 11.4 L/h (3 gallons per hour). The nozzle shall be held 300 – 380 mm (12 – 15 inches) from the enclosure and the spray of water shall be directed once at all points of potential dust entry such as seams, joints, and external operating mechanisms. A conduit may be installed to equalize the internal and external pressures, but shall not serve as a drain. The test specimen shall have at least one seam representative of each of the types of seams of the enclosure(s). A seam is the junction of, or the joint between, two pieces. When two covers or doors are adjacent, their common edges shall be considered a single seam.

8.4.2.1.2.2 The enclosure shall be considered to have met the requirements if at the conclusion of the test no water has entered the enclosure.

## 8.4.2.2 Settling dust test

### 8.4.2.2.1 Dust method

8.4.2.2.1.1 At least 0.85 kilograms of dry Type 1 General Purpose Portland cement (see Table 4) per cubic meter of test chamber (0.85 ounces per cubic foot) shall be circulated by means of a blower suction unit so as to completely envelop the enclosure under test. The air velocity at the outlet of the blower is to be 304.8 meters per minute (1000 feet per minute). The blower shall be cycled 15 seconds on and 30 seconds off for seven complete cycles.

8.4.2.2.1.2 The enclosure shall be considered to have met the requirements if at the conclusion of the test no dust has entered the enclosure.

### 8.4.2.2.2 Atomized-water method (Method B)

8.4.2.2.2.1 The enclosure shall be subjected to a spray of atomized water using a nozzle that produces a round pattern 75 – 100 mm in diameter when measured 300 mm from the nozzle (3 – 4 inches in diameter when measured 12 inches from the nozzle). The air pressure shall be 170 kPa (25 psi). A quantity of 2.9 mL/linear cm (3 ounces per linear foot) shall be applied at a flow rate of 11.4 L/h (3 gallons per hour). The nozzle shall be held 460 – 530 mm (18 – 21 inches) away from the enclosure and the spray of water shall be directed once at all points of potential dust entry such as seams, joints, and external operating mechanisms. A conduit may be installed to equalize the internal and external pressure, but shall not serve as a drain. The test specimen shall have at least one seam representative of each of the types of seams of the enclosure(s). A seam is the junction of, or the joint between, two pieces. When two covers or doors are adjacent, their common edges shall be considered a single seam.

8.4.2.2.2.2 The enclosure shall be considered to have met the requirements if at the conclusion of the test no water has entered the enclosure.

## 8.5 External icing test

8.5.1 The enclosure shall be mounted in a room which can be cooled to minus 7°C (20°F). A metal test bar which is 25.4 mm in diameter by 600 mm long (1 inch in diameter and 2 feet long) shall be mounted in a horizontal position in a location where it will receive the same general water spray as the enclosure under test. Provision shall be made for spraying the entire enclosure from above with water at an angle of approximately 45 degrees from the vertical. The water shall be between 0°C (32°F) and 3°C (37°F). Spraying facilities which provide between 40 – 80 L/h/m<sup>2</sup> (1 – 2 gallons per hour per square foot) of area to be sprayed have been found effective. The room temperature shall be lowered to 2°C (35°F). The spray of water shall be started and continued for at least 1 hour, maintaining the room temperature between 1°C (33°F) and 3°C (37°F). At the end of this time, the room temperature shall be lowered to between minus 7°C (20°F) and minus 3°C (27°F) while continuing the water spray. (The rate of change in the room temperature is not critical and shall be whatever is obtainable with the cooling means employed.) The water spray shall be controlled so as to cause ice to build up on the bar at a rate of approximately 6.35 mm per hour (1/4 inch per hour) and shall be continued until 20 mm (3/4 inch) of ice has formed on the top surface of the bar. The spray shall then be discontinued but the room temperature shall be maintained between minus 7°C (20°F) and minus 3°C (27°F) for 3 hours to assure that all parts of the enclosure and ice coatings have been equalized to a constant temperature.



8.5.2 A Type 3S enclosure and its external mechanisms shall be considered to have met the requirements of this test if while ice laden, they can be manually operated by one person without any damage to the enclosure, the enclosed equipment, or mechanism. When an auxiliary mechanism is provided to break the ice, it shall be included and utilized in the test. A separate test is required for each maintained position of each external operator. If necessary, it shall be possible to gain access to the enclosure interior using an appropriate hand tool without causing functional damage to the enclosure.

8.5.3 A Type 3, 3R, 4, 4X, 6, or 6P enclosure shall be considered to have met the requirements if at the conclusion of the test the enclosure is found to be undamaged after the ice has melted.

## **8.6 Hosedown test**

8.6.1 The enclosure and its external mechanisms shall be subjected to a stream of water from a hose that has a 25 mm inside diameter (1 inch inside diameter) nozzle that delivers at least 240 L per minute (65 gallons per minute). The water shall be directed at all joints from a distance of 3.0 – 3.5 m (10 – 12 feet). The nozzle shall be moved along each joint one time at a uniform nominal rate of 6 mm/s (1/4 inch per second). A conduit may be installed to equalize internal and external pressures, but shall not serve as a drain.

8.6.2 The enclosure shall be considered to have met the requirements if at the conclusion of the test no water has entered the enclosure.

## **8.7 Indoor corrosion protection**

### **8.7.1 24-hour salt spray test**

#### **8.7.1.1 General**

8.7.1.1.1 Unless the enclosures comply with 7.2.2.1, the enclosure or representative parts or plaques of the enclosure shall be subjected to a salt spray (fog) using the test method described below.

#### **8.7.1.2 Test equipment**

8.7.1.2.1 The test apparatus shall consist of a fog chamber, a salt-solution reservoir, a supply of compressed air, atomizing nozzles, support for the enclosure, provision for heating the chamber, and means of control.

#### **8.7.1.2.2 The test apparatus shall:**

- a) Not permit drops of solution that accumulate on the ceiling or cover of the chamber to fall on the enclosure being tested;
- b) Not permit drops of solution that fall from the enclosure to be returned to the solution reservoir for re-spraying; and
- c) Be constructed of materials that will not affect the corrosiveness of the fog.

### 8.7.1.3 Salt solution

8.7.1.3.1 The salt solution shall be prepared by dissolving 5 parts by weight of salt in 95 parts by weight of either distilled water or water containing not more than 200 parts per million of total solids. The salt shall be sodium chloride which is substantially free of nickel and copper and which contains, when dry, not more than 0.1 percent of sodium iodide and not more than 0.3 percent of total impurities.

### 8.7.1.4 Air supply

8.7.1.4.1 The compressed air supply to the nozzle(s) for atomizing the salt solution shall be free of oil and dirt and shall be maintained between 69 and 172 kPa (between 10 and 25 psi).

### 8.7.1.5 Temperature

8.7.1.5.1 The temperature of the salt spray chamber shall be maintained between 33°C and 36°C (between 92°F and 97°F). The nozzle(s) shall be directed or baffled so that none of the spray can impinge directly on the enclosure being tested.

### 8.7.1.6 Test procedure

8.7.1.6.1 The chamber shall be closed and the spray operated continuously, except for the short daily interruption necessary to inspect, rearrange, or remove the test specimens, to check and replenish the solution in the reservoir, and to make necessary recordings.

8.7.1.6.2 The test shall be run continuously for 24 hours. At the end of the test, the specimens shall be removed from the chamber and washed in clean running water that is not warmer than 38°C (100°F) to remove salt deposits from their surface, and then dried immediately. Corrosion products, other than rust, may be removed by light brushing if required, to observe the condition of the underlying stratum.

### 8.7.1.7 Evaluation

8.7.1.7.1 The enclosure shall be considered to have met the requirements of this test if there is no rust except at those points where protection is impractical, such as machined and mating surfaces of cast enclosures and sliding surfaces of hinges, shafts, and so forth.

## 8.8 Outdoor corrosion protection

### 8.8.1 600-hour salt spray test

8.8.1.1 Finishes other than as described in 7.2.3.1 (a) – (d), such as special metallic finishes, or metallic finish combined with paint, shall be tested in accordance with 8.7, except the time shall be 600 hours when compared with G90 galvanized sheet steel (without annealing, wiping, or other surface treatment) conforming with 7.2.3.1(a).

8.8.1.2 An enclosure shall be considered to have met the requirements of this test if upon completion it does not show pitting, cracking, or other deterioration more severe than that resulting from a similar test on G90 galvanized sheet steel.

### 8.8.2 1200-hour moist carbon dioxide-sulphur dioxide-air test

#### 8.8.2.1 General

8.8.2.1.1 Two unscribed specimens and two specimens scribed in accordance with 8.8.2.1.1 shall be tested.

#### 8.8.2.2 Scribed specimens

8.8.2.2.1 Where specified or agreed upon, each specimen shall be prepared for testing by scribing it in such a manner that the scribe can be exposed lengthwise when positioned in the test cabinet. This position will allow solution droplets to run lengthwise along the scribe.

8.8.2.2.2 Scribe the specimen by holding the tool at approximately a 45-degree angle to the surface. Position the tool so that only the carbide is in contact with the surface. Pull the scribing tool to obtain a uniform V-cut through the coating that is being tested. Inspect the tool frequently for dulling, chipping, or wear and replace or repair as needed. The scribe should be of sufficient length to cover significant test area, but should not contact the edge of the specimen. The scribe shall penetrate all the organic coating layers on the metal, leaving a uniformly bright line of burrs. The extent of scribe penetration through metallic coatings should be agreed upon between the producer and user. The quality of the scribe may be observed with the aid of low-power magnification. Defects, coding, and flaws that may affect results shall be noted, marked, and described.

### 8.8.2.3 Test procedure

8.8.2.3.1 The apparatus used for the moist carbon dioxide-sulfur dioxide-air exposure shall consist of a chamber having a volume of at least 0.08 m<sup>3</sup> (3 cubic feet) with a water jacket and thermostatically controlled heater to maintain a temperature of 35 plus 1.1 or minus 1.7 °C (95 plus 2 or minus 3 °F).

8.8.2.3.2 Sulfur dioxide and carbon dioxide shall be supplied to the test chamber from commercial cylinders containing the gases under pressure. An amount of sulfur dioxide equivalent to 1 percent of volume of the test chamber, and an equal volume of carbon dioxide, shall be introduced into the chamber each working day. Prior to introducing the new charge of gas each day, the remaining gas-air mixture from the previous day is to be purged from the chamber. A small amount of water (approximately 10 ml/0.0003 m<sup>3</sup> of chamber volume) shall be maintained at the bottom of the chamber for humidity. This water shall not be changed during the exposure.

8.8.2.3.3 The specimens shall be supported in plastic racks at an angle of 15 to 30 degrees from the vertical.

8.8.2.3.4 An enclosure shall be considered to have met the requirements of this test if upon completion, specimens:

- a) Except for the scribe, do not show more than light corrosion beneath the coating, with no visual pitting of substrate and only incipient buildup or weeping of corrosion products;
- b) Comply with Table 6; and
- c) Do not exhibit an average creepage distance from the scribe greater than Rating No. 6 [1.6 – 3.2 mm (1/16 – 1/8 inch)] as designated in Procedure A, Method 2, as specified in Annex B, Ref. No. 4, with maximum isolated spot not exceeding 9.5 mm (3/8 inch).

## 8.9 Additional corrosion protection for type 4X and 6P

### 8.9.1 200-hour salt spray test

8.9.1.1 Materials other than Type 304 stainless steel, Type 316 stainless steel, and polymerics shall be tested in accordance with 8.7, except the time shall be 200 hours.

8.9.1.2 An enclosure shall be considered to have met the requirements of this test if upon completion it does not show pitting, cracking, or other deterioration more severe than that resulting from a similar test on passivated American Iron and Steel Institute Type 304 stainless steel.

## 8.10 Submersion test

8.10.1 The complete enclosure shall be mounted in a tank, with the conduit connected using pipe-thread sealing compound. The conduit shall be tightened with the torque values specified in Table 3. The tank shall be filled with water so that the highest point of the enclosure is 1.8 meters below the surface (6 feet below the surface) of the water. After 30 minutes, the enclosures shall be removed from the tank, the excess water removed from the surface of the enclosure, and the enclosure opened. The enclosure need not be submersed to a depth of 1.8 meters (6 feet) if an equivalent pressure differential between the interior and the exterior of the enclosure is maintained for the required period of time. This differential may be achieved either by reducing the air pressure inside the enclosure or pressurizing the water surrounding the enclosure.

8.10.2 The enclosure shall be considered to have met the requirements if at the conclusion of the test no water has entered the enclosure.

## 8.11 Pressure test

### 8.11.1 Internal pressurization method

8.11.1.1 The complete enclosure with conduit, pressure gage, and check valve shall be pressure tested. The internal air pressure of the enclosure shall be raised to 40 kPa (6 psig) and the check valve closed. After 24 hours the pressure shall be checked. The conduit shall be connected using pipe-thread sealing compound and shall be tightened with the torque specified in Table 3.

8.11.1.2 The enclosure shall be considered to have met the requirements if at the conclusion of the test the internal pressure is a minimum of 26 kPa (4 psig) and there is no permanent deformation of the enclosure.

### 8.11.2 External pressurization method

8.11.2.1 Submerge the complete enclosure, connected as intended for use, in water so that the highest point of the enclosure is 1.8 meters below the surface (6 feet) for a period of 24 hours. The enclosure need not be submerged to a depth of 1.8 m (6 feet) if the equivalent pressure differential between the interior and exterior of the enclosure is maintained for the required period of time. This differential may be achieved either by reducing the air pressure inside the enclosure or by pressurizing the water around the enclosure to simulate a depth of 1.8 meters (6 feet).

8.11.2.2 The enclosure shall be considered to have met the requirements if at the conclusion of the test no water has entered the enclosure.

## 8.12 Oil exclusion test

8.12.1 To assure against entry of liquid via the conduit, it is recommended that during installation, the conduit and the wiring in it be tightly sealed at the point of entry to the enclosure by an oil and coolant resistant compound or equivalent means.

8.12.2 The compatibility of the gasket with other sealing materials and liquids to which it is exposed will in some cases have to be determined by tests.

8.12.3 The enclosure shall be subjected to a stream of test liquid consisting of water and a wetting agent. The concentration of the wetting agent shall be approximately 0.1 percent by weight (or by volume if the wetting agent is liquid).

8.12.4 The liquid shall be supplied through a nozzle that delivers at least 7 L/min (2 gallons per minute). One such nozzle shall have an opening of 10 mm diameter (opening of 3/8 inch diameter). The stream shall be directed upon the enclosure from all angles from a distance of 300 – 460 mm (12 – 18 inches) for 30 minutes. If the enclosure houses an externally operated device, the device shall be operated at a rate of approximately 30 operations per minute for the duration of the test. A conduit may be installed to equalize internal and external pressures, but shall not serve as a drain.

*Note: One such wetting agent is Rohm and Haas' Triton X-100.*

8.12.5 The enclosure shall be considered to have met the requirements if at the conclusion of the test no test liquid has entered the enclosure.

## 8.13 Gasket tests

### 8.13.1 General

8.13.1.1 The tests specified in 8.13.2 and 8.13.3 are applicable to gaskets employed on enclosure Types 2, 3, 3R, 3S, 4, 4X, 5, 6, 6P, 12, 12K, and 13. The test of 8.13.4 is applicable to gaskets employed on enclosure Types 12, 12K, and 13.

### 8.13.2 Tensile strength and elongation tests

8.13.2.1 Gasket material, if used in a Type 2, 3, 3R, 3S, 4, 4X, 5, 6, 6P, 12, 12K, or 13 enclosure, shall be of such quality that samples subjected to a temperature of 69 – 70°C (156 – 158°F) in circulating air for 168 hours have a tensile strength of not less than 75 percent and an elongation of not less than 60 percent of values determined for unaged samples. At the conclusion of the tests, there shall be no visible deterioration, deformation, melting, or cracking of the material, and the material shall not harden as determined by normal hand flexing.

### 8.13.3 Compression test

8.13.3.1 A set of three specimens of gasket material, if used in a Type 2, 3, 3R, 3S, 4, 4X, 5, 6, 6P, 12, 12K, or 13 enclosure, shall be tested to the requirements of 8.13.3.2 – 8.13.3.4 (see Figure 3). On completion of each test the specimen shall not show signs of deterioration or cracks that can be seen with normal or corrected vision.

8.13.3.2 A circular weight to apply 69 kPa (10 pounds per square inch) shall be placed on the middle portion of each specimen for a period of 2 hours. At the end of that time the weight shall be removed and the specimen allowed to rest at room temperature for 30 minutes. The thickness of the gasket shall then be determined and compared with a measurement obtained before the application of the weight. The compression set shall not exceed 50 percent of the initial thickness of the specimen.

8.13.3.3 Following the test specified in 8.13.3.2, the specimens shall be suspended in an air oven at a temperature of 70°C (158°F) for a period of 5 days. The specimens shall then be tested for compliance with 8.13.3.2, approximately 24 hours after removal from the oven.

8.13.3.4 Following the test specified in 8.13.3.3, the specimens shall be cooled to a temperature of minus 30°C (minus 22°F) for a period of 24 hours and then subjected to an impact from a hammer of 1.35 kg mass (2.98 pounds) falling from a height of 150 mm (6 inches). The hammer head shall be steel, 28.6 mm (1-1/8 inches) in diameter, and have a flat striking surface, 25.4 mm (1 inch) in diameter, with slightly rounded edges. The specimens being tested shall be placed on short lengths of 50 by 100 mm (2 by 4 inch) minimum wooden pieces (clear spruce) when being impacted. Following the impact the specimens shall be examined for evidence of cracking or other adverse effects. The test shall be continued and the specimens impacted every 24 hours for two more days. The specimens shall then be removed from the cold chamber, allowed to rest at room temperature for approximately 24 hours, and then tested for compliance with 8.13.3.2.

### 8.13.4 Oil immersion test

8.13.4.1 Gasket material, if used in a Type 12, 12K, or 13 enclosure, shall not swell more than 25 percent or shrink more than 1 percent as a result of immersion in Immersion Oil No. 903 for 70 hours at room temperature.

*Note: Specifications for Immersion Oil No. 903 can be found in ASTM D 471.*

## 8.14 Rod entry test

### 8.14.1 Ventilated enclosures test method

8.14.1.1 For ventilated enclosures with live parts less than 102 mm (less than 4 inches) from the opening, this test shall be made by attempting to insert a rod having a diameter of 12.7 mm (a diameter of 1/2 inch).

8.14.1.2 For ventilated enclosures with live parts located 102 mm or more (4 inches or more) from the opening, this test shall be made by attempting to insert a rod having a diameter of 19 mm (a diameter of 3/4 inch).

### 8.14.2 Evaluation

8.14.2.1 The enclosure shall be considered to have met the requirements if the rod cannot enter the enclosure.

## 8.15 Misalignment test

### 8.15.1 General

8.15.1.1 A 3 m (10 foot) length of steel conduit, trade size 3, shall be tightly threaded into a detachable threaded conduit hub, and the hub shall be installed in one or more of the conduit locations in the enclosure to be tested. A conduit of smaller size shall be used if the maximum size of conduit the enclosure is designed to accept is smaller than trade size 3. The opposite end of the conduit from the enclosure shall be displaced from its axis in all directions by a distance of 75 mm (3 inches), except that the displacement shall be reduced if necessary to avoid exceeding the bending moment value specified in Table 5.

### 8.15.2 Evaluation

8.15.2.1 As a result of the test, the non-metallic enclosure shall not crack or break and the enclosure shall meet the applicable environmental tests of 8.2, 8.3, 8.4, 8.6, or 8.11.

8.15.2.2 As a result of the test, a metallic enclosure shall not be permanently distorted and the enclosure shall meet the applicable environmental tests of 8.2, 8.3, 8.4, 8.6, or 8.11.



## 8.16 Water exposure and immersion

### 8.16.1 General

8.16.1.1 A polymeric material used for the enclosure of electrical equipment intended for outdoor installation shall not be appreciably degraded because of exposure to water. The acceptability of the material's resistance to such degradation may be judged by the procedure described in Annex D.

## 9 Marking

### 9.1 General

*Advisory Note: In Canada, there are two official languages, English and French. Markings required by this standard will in some cases have to be provided in other languages to conform with the language requirements of the country where the product is to be used.*

### 9.2 Type designations

9.2.1 Enclosures shall be designated by the type number which is intended to indicate the environmental conditions for which they are suitable, for example, "Type \_\_ Enclosure", or equivalent.

9.2.2 Enclosures that comply with the requirements for more than one type enclosure may be designated by a combination of type numbers, the lower number being given first.

9.2.3 Ventilated Type 1, 2, or 3R enclosures in which the equipment to be installed is not known shall be marked to indicate the area in which live parts are to be installed.

### 9.3 Supplemental markings

9.3.1 Enclosures may be additionally marked with the supplemental markings in 9.3.2 – 9.3.7. These are relative terms for reference purposes only and do not imply enclosure capabilities.

9.3.2 A Type 3, 3S, 4, 4X, 6, or 6P enclosure may be marked "Raintight".

9.3.3 A Type 3R enclosure may be marked "Rainproof".

9.3.4 A Type 4, 4X, 6, or 6P enclosure may be marked "Watertight".

9.3.5 A Type 4X or 6P enclosure may be marked "Corrosion Resistant".

9.3.6 A Type 2, 5, 12, 12K, or 13 enclosure may be marked "Driptight".

9.3.7 A Type 3, 3S, 5, 12, 12K, or 13 enclosure may be marked "Dusttight".

## 9.4 Location

9.4.1 Markings may be placed at any point on the inside or outside surface of the enclosure or door where they will be readily visible after installation.

9.4.2 In the United States, markings shall additionally comply with the requirements in Annex C.

## 9.5 Orientation

9.5.1 If the acceptability of a Type 2 or 3R enclosure is dependent upon a particular mounting orientation, the enclosure shall be marked to indicate the required orientation unless the mounting is obvious.

9.5.2 If a Type 2 or 3R enclosure has knockouts for conduit in the sides or back of the enclosure in which the equipment to be installed is not known, it shall be marked to indicate the area in which live parts are to be installed.

9.5.3 Other than as permitted by 9.5.4, a Type 2 or 3R enclosure that allows water to enter shall be marked or provided with instructions indicating the areas in which live parts shall or shall not be located.

9.5.4 When it has been determined that the water does not enter the enclosure above an area intended for live parts, the marking in 9.5.3 is not required for enclosures containing live parts or for enclosures marked to specify the equipment intended to be mounted within the enclosure.

## 9.6 Equipment openings

9.6.1 Enclosures intended for use with conduit hubs, closure plates, and other equipment (such as push-button switches) intended to be field installed shall be marked or provided with instructions that identify the equipment necessary to maintain the environmental integrity of the enclosure. This may be accomplished by identifying the necessary environmental type designation or by identifying the specific manufacturer and model number of the field installed equipment.

## 9.7 Drainage openings

9.7.1 Types 2 and 3R enclosures that are constructed in accordance with 7.3.3.2 shall have instructions indicating that the drainage hole plugs shall be removed for Type 2 or 3R applications and shall be in place for other applications.

9.7.2 Types 2 and 3R enclosures that are constructed in accordance with 7.3.3.3 shall have instructions indicating the method of (obtaining) providing drainage openings when the enclosure is being used for Types 2 and 3R applications.

**Table 1**  
**Comparison of specific applications of enclosures for indoor and outdoor nonhazardous locations**

(See 6.3)

Provides a degree of protection against the following environmental conditions	Type of enclosure												
	1 <sup>a</sup>	2 <sup>a</sup>	3	3R <sup>a</sup>	3S	4	4X	5	6	6P	12	12K	13
Incidental contact with the enclosed equipment	X	X	X	X	X	X	X	X	X	X	X	X	X
Falling dirt	X	X	X	X	X	X	X	X	X	X	X	X	X
Dripping and light splashing of non-corrosive liquids		X	X	X	X	X	X	X	X	X	X	X	X
Rain, snow, and sleet <sup>b</sup>			X	X	X	X	X		X	X			
Rain, snow, and sleet <sup>c</sup>					X								
Circulating dust, lint, fibers, and flyings <sup>d</sup>			X		X	X	X		X	X	X	X	X
Settling airborne dust, lint, fibers, and flyings <sup>d</sup>			X		X	X	X	X	X	X	X	X	X
Windblown dust			X		X	X	X		X	X			
Hosedown and splashing water						X	X		X	X			
Oil and coolant seepage											X	X	X
Oil or coolant spraying and splashing													X
Corrosive agents							X			X			
Occasional temporary submersion									X	X			
Occasional prolonged submersion										X			

<sup>a</sup> These enclosures may be ventilated.  
<sup>b</sup> External operating mechanisms are not required to be operable when the enclosure is ice covered.  
<sup>c</sup> External operating mechanisms are operable when the enclosure is ice covered. See 8.5.2.  
<sup>d</sup> These fibers and flyings are nonhazardous materials and are not considered Class III type ignitable fibers or combustible flyings. (For Class III type ignitable fibers or combustible flyings, see the Canadian Electrical Code, Part I, Section 18, the National Electrical Code, Article 500, or Mexico's NOM-001-SEDE, Electrical Installations (utility), Article 500.

**Table 2**  
**Applicable design tests**

(See 7.3.1.1 and 8.1.2)

Enclosure type	Applicable tests	Clause
1	Rod entry <sup>a</sup>	8.14
	Indoor corrosion protection	8.7
2	Rod entry <sup>a</sup>	8.14
	Drip <sup>b</sup>	8.2
	Indoor corrosion protection	8.7
	Gasket	8.13
	Misalignment	8.15
3	Outdoor dust <sup>d</sup>	8.4.1
	External icing <sup>g</sup>	8.5
	Outdoor corrosion protection	8.8
	Gasket	8.13
	Misalignment	8.15
3R	Rod entry <sup>a</sup>	8.14
	Rain <sup>c</sup>	8.3

**UL COPYRIGHTED MATERIAL –  
 NOT AUTHORIZED FOR FURTHER REPRODUCTION OR  
 DISTRIBUTION WITHOUT PERMISSION FROM UL**

Table 2 Continued on Next Page

Table 2 Continued

Enclosure type	Applicable tests	Clause
	External icing <sup>g</sup>	8.5
	Outdoor corrosion protection	8.8
	Gasket	8.13
	Misalignment	8.15
3S	Outdoor dust <sup>d</sup>	8.4.1
	External icing <sup>g</sup>	8.5
	Outdoor corrosion protection	8.8
	Gasket	8.13
	Misalignment	8.15
4	External icing <sup>g</sup>	8.5
	Hosedown <sup>h</sup>	8.6
	Outdoor corrosion protection	8.8
	Gasket	8.13
	Misalignment	8.15
4X	External icing <sup>g</sup>	8.5
	Hosedown <sup>h</sup>	8.6
	Outdoor corrosion protection	8.8
	Additional corrosion protection	8.9
	Gasket	8.13
	Misalignment	8.15
5	Indoor settling dust <sup>f</sup>	8.4.2.2
	Indoor corrosion protection	8.7
	Gasket	8.13
	Misalignment	8.15
6	External icing <sup>g</sup>	8.5
	Outdoor corrosion protection	8.8
	Submersion <sup>i</sup>	8.10
	Gasket	8.13
	Misalignment	8.15
6P	External icing <sup>g</sup>	8.5
	Outdoor corrosion protection	8.8
	Additional corrosion protection	8.9
	Pressure <sup>j</sup>	8.11
	Gasket	8.13
	Misalignment	8.15
12, 12K	Indoor (circulating) dust <sup>e</sup>	8.4.2.1
	Indoor corrosion protection	8.7
	Gasket	8.13
	Misalignment	8.15
13	Indoor corrosion protection	8.7
	Oil exclusion <sup>k</sup>	8.12
	Gasket	8.13
	Misalignment	8.15

<sup>a</sup> Required only when ventilated. The rod entry test is intended to simulate incidental contact with enclosed equipment; see Table 1.

<sup>b</sup> The drip test is intended to simulate dripping and light splashing of liquids; see Table 1. The drip test method A described in 8.2.1 and method B described in 8.2.2 are alternate drip test methods.

<sup>c</sup> The rain test is intended to simulate falling rain; see Table 1. A device that meets the requirements of the Rain test also meets the requirements of the Drip test in 8.2.

**UL COPYRIGHTED MATERIAL –  
NOT AUTHORIZED FOR FURTHER REPRODUCTION OR  
DISTRIBUTION WITHOUT PERMISSION FROM UL**

Table 2 Continued on Next Page

**Table 2 Continued**

Enclosure type	Applicable tests	Clause
	<p><sup>d</sup> The outdoor dust test is intended to simulate windblown dust; see Table 1. The Dust blast method described in 8.4.1.1 and the hose method described in 8.4.1.2 are alternate outdoor dust tests. A device that meets the requirements of the Outdoor dust test also meets the requirements of the Circulating dust test in 8.4.2.1, the Settling dust test in 8.4.2.2, the Drip test in 8.2, and the Rain test in 8.3.</p>	
	<p><sup>e</sup> The indoor circulating dust test is intended to simulate an indoor industrial environment of circulating dust, lint, fibers, and flyings; see Table 1. This test, in conjunction with the oil-resistant gaskets of Type 12 and Type 12K devices, also demonstrates a degree of protection against light splashing and consequent seepage of oil and non-corrosive coolants. The dust method described in 8.4.2.1.1 and the atomized water method (method A) described in 8.4.2.1.2 are alternate circulating dust tests. A device that meets the requirements of the Indoor circulating dust test also meets the requirements of the Settling dust test, 8.4.2.2, and the Drip test in 8.2.</p>	
	<p><sup>f</sup> The settling dust test is intended to simulate an indoor industrial environment of settling airborne dust, lint, fibers, and flyings; see Table 1. The dust method described in 8.4.2.2.1 and Atomized water method (method B) described in 8.4.2.2.2 are alternate settling dust tests. A device that meets the requirements of the Settling dust test also meets the requirements of the Drip test in 8.2.</p>	
	<p><sup>g</sup> The external icing test is intended to simulate freezing rain, sleet, and snow; see Table 1. A Type 3, 3R, 4, 4X, 6, and 6P enclosure which has no external cavities to trap water when mounted in the normal position is not required to be subjected to the External icing test.</p>	
	<p><sup>h</sup> The hosedown test is intended to simulate a hosedown condition; see Table 1. A device that meets the requirements of the hosedown test also meets the requirements of the Drip test in 8.2, Rain test in 8.3, and Dust tests in 8.4.</p>	
	<p><sup>i</sup> The submersion test is intended to simulate temporary submersion at a limited depth; see Table 1. A device that meets the requirements of the submersion test also meets the requirements of the Dust test, 8.4, and the Hosedown test, 8.6.</p>	
	<p><sup>j</sup> The pressure test is intended to simulate prolonged submersion at a limited depth; see Table 1. The Internal pressurization method described in 8.11.1 and the External pressurization method described in 8.11.2 are alternate pressure tests. A device that meets the requirements of the pressure test also meets the requirements of the Submersion test in 8.10.</p>	
	<p><sup>k</sup> The oil exclusion test is intended to simulate spraying water, oil and non-corrosive coolant; see Table 1. A device that meets the requirements of the Oil exclusion test also meets the requirements of the Rain test, 8.3, and the Dust tests, 8.4.</p>	

**Table 3  
Tightening torque**

(See 8.3.1, 8.10.1, and 8.11.1.1)

Torque <sup>a</sup>		Trade size of conduit
N-m	(Pound-inches)	
90.4	800	3/4 and smaller
113	1000	1, 1-1/4 and 1-1/2
180.8	1600	2 and larger

<sup>a</sup> In accordance with 1.4, other values may be specified by end-use product standards.

**Table 4**  
**Particle size**

(See 8.4.1.1.1, 8.4.2.1.1.2, and 8.4.2.2.1.1)

Mesh	mm	(inches)	Percent content
Coarser than 200	Larger than 0.074	(0.0029)	3
200	0.074	(0.0029)	8
325	0.043	(0.0017)	7
400	0.038 or smaller	(0.0015)	82

**Table 5**  
**Bending moment for misalignment test**

(See 8.15.1.1)

Normal mounting plane of enclosure surface	Conduit trade size	Bending moment N-m (lb-ft)	
		Metallic conduit	Nonmetallic conduit
Horizontal	All	34 (2.5)	34 (2.5)
Vertical	1/2 – 3/4	34 (2.5)	34 (2.5)
	1 and up	68 (5.0)	34 (2.5)

**Table 6**  
**Blister size and frequency**

(See 8.8.2.3.4)

Maximum size <sup>a</sup>	Maximum frequency
2	None
4 or 6	Medium
8	Medium dense

Note – Compliance is to be determined in accordance with Annex B, Ref. No. 5.  
<sup>a</sup> The largest blister size is Number 2 and the smallest blister size is Number 8.

Figure 1 – Rain-test spray-head piping

(See 8.3.2)

PLAN VIEW

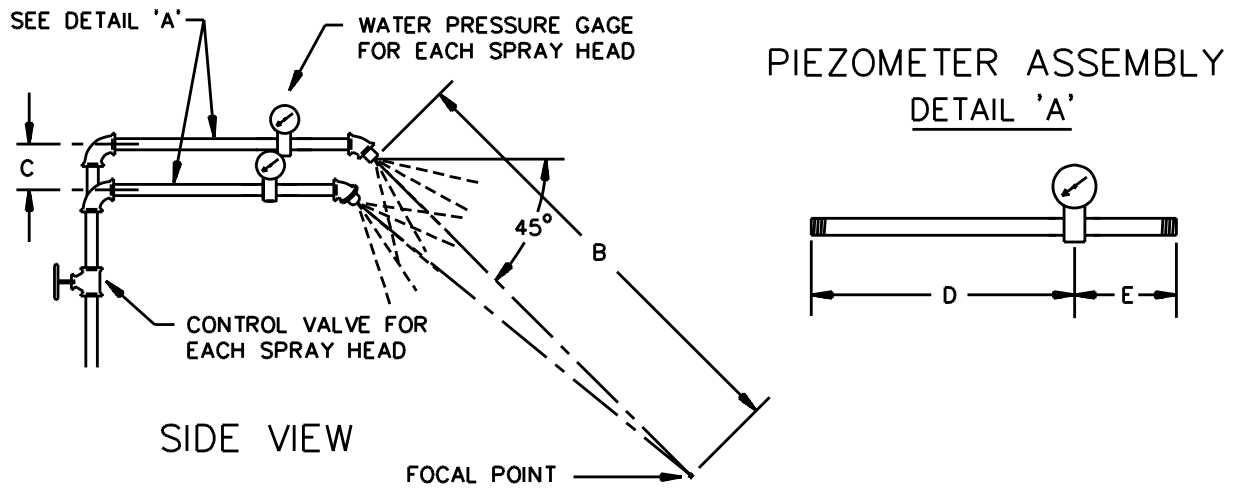
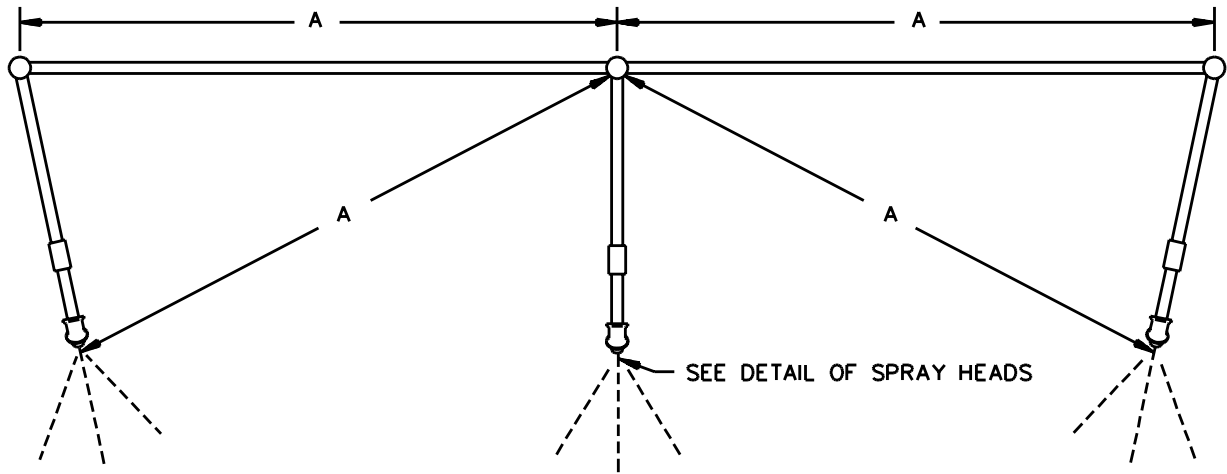

Item	mm	inch
A	710	28
B	1400	55
C	55	2-1/4
D	230	9
E	75	3

RT101F

UL COPYRIGHTED MATERIAL –  
 NOT AUTHORIZED FOR FURTHER REPRODUCTION OR  
 DISTRIBUTION WITHOUT PERMISSION FROM UL

**Figure 2 – Rain-test spray head**

(See 8.3.2)

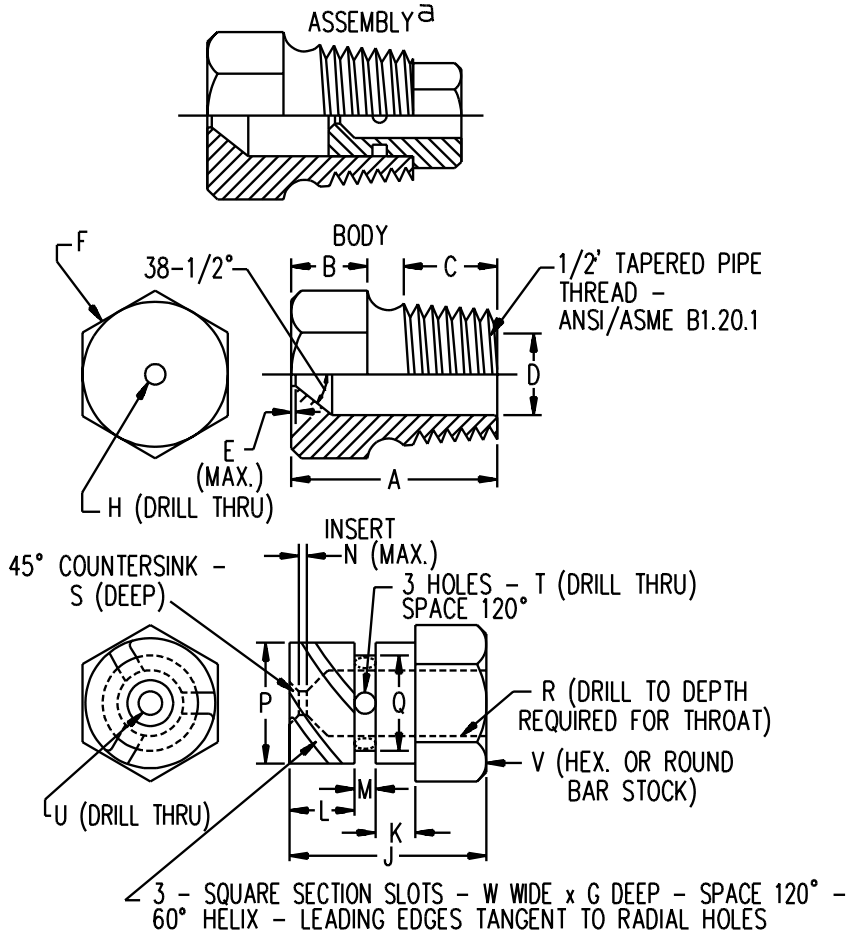

Item	mm	inch	Item	mm	inch
A	31.0	1-7/32	N	0.80	1/32
B	11.0	7/16	P	14.61	.575
C	14.0	9/16		14.63	.576
D	14.68	.578	Q	11.51	.453
	14.73	.580		11.53	.454
E	0.40	1/64	R	6.35	1/4
F	c	c	S	0.80	1/32
G	1.52	.06	T	2.80	(No. 35) <sup>b</sup>
H	5.0	(No.9) <sup>b</sup>	U	2.50	(No. 40) <sup>b</sup>
J	18.3	23/32	V	16.0	5/8
K	3.97	5/32	W	1.52	0.06
L	6.35	1/4			
M	2.38	3/32			

<sup>a</sup> Nylon Rain-Test Spray Heads are available from Underwriters Laboratories

<sup>b</sup> ANSI B94.11M Drill Size

<sup>c</sup> Optional – To serve as a wrench grip.

RT100F

**UL COPYRIGHTED MATERIAL –  
NOT AUTHORIZED FOR FURTHER REPRODUCTION OR  
DISTRIBUTION WITHOUT PERMISSION FROM UL**



Figure 3 – Gasket test

(See 8.13.3.1)

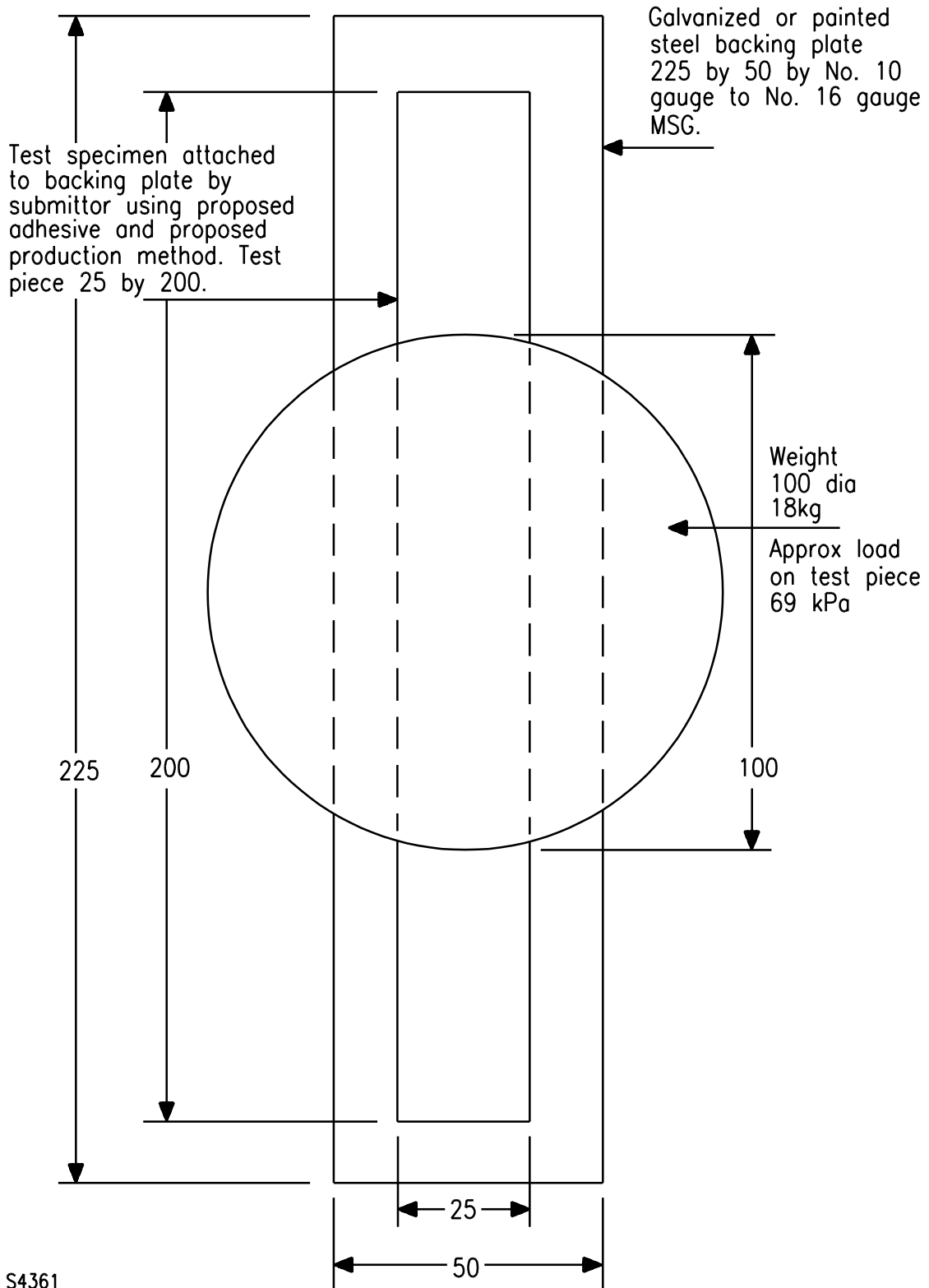

## Annex A – Standards For Components (Normative)

A1.1 The ANCE, CSA, and UL Standards listed below are used for evaluation of components and features of products covered by this standard. Components need only comply with the applicable component standard acceptable in the country where the product is to be used. These standards shall be considered to refer to the latest edition and all revisions published to that edition.

A1.2 Standards under which components of the products covered by this standard are evaluated include the following:

### **ANCE Standards**

NMX-J-017-ANCE,  
*Conduit, Tubing and Cable Fittings*

NMX-J-023/1-ANCE,  
*Metallic Outlet Boxes*

NMX-J-515-ANCE,  
*Industrial Distribution and Control Equipment*

NMX-J-543-ANCE,  
*Wire Connectors*

### **CSA Standards**

C22.2 No. 0-M91 (R2006),  
*General Requirements – Canadian Electrical Code, Part II*

CAN/CSA C22.2 No. 0.4-04,  
*Bonding of Electrical Equipment*

C22.2 No. 0.5-82 (R2003),  
*Threaded Conduit Entries*

C22.2 No. 0.15–01 (R2006),  
*Adhesive Labels*

CAN/CSA C22.2 No. 0.17-00 (R2004),  
*Evaluation of Properties of Polymeric Materials*

C22.2 No. 14-05,  
*Industrial Control Equipment*

C22.2 No. 18-98 (R2003),  
*Outlet Boxes, Conduit Boxes, Fittings and Associated Hardware*

C22.2 No. 41-M1987 (R2004),  
*Grounding and Bonding Equipment*

**UL COPYRIGHTED MATERIAL –  
NOT AUTHORIZED FOR FURTHER REPRODUCTION OR  
DISTRIBUTION WITHOUT PERMISSION FROM UL**

CAN/CSA C22.2 No. 65-03,  
*Wire Connectors*

**UL Standards**

UL 94  
*Tests for Flammability of Plastic Materials for Parts in Devices and Appliances*

UL 467  
*Grounding And Bonding Equipment*

UL 486A-486B  
*Wire Connectors*

UL 514B  
*Conduit, Tubing and Cable Fittings*

UL 746A  
*Polymeric Materials – Short Term Property Evaluations*

UL 746C  
*Polymeric Materials – Use in Electrical Equipment Evaluations*

UL 969  
*Marking and Labeling Systems*

UL 1332  
*Organic Coatings for Steel Enclosures for Outdoor Use Electrical Equipment*

**Annex B – Reference Standards**  
(Normative)

Ref. No.	Clause No.	Canada	Mexico	United States
1	7.1.1	CAN/CSA C22.2 No. 0.17 -00 (R2004), Evaluation of Properties of Polymeric Materials	NMX-J-235/2-ANCE, Enclosures for Electrical Equipment, Environmental Considerations	Polymeric Materials – Use in Electrical Equipment Evaluations, UL 746C
2	7.2.3.1(a), 7.2.3.1(c)(1)	ASTM A 653/A653M – 05, Standard Specification for Steel Sheet, Zinc-Coated (Galvanized) or Zinc-Iron Alloy-Coated (Galvannealed) by the Hot-Dip Process	No Equivalent	ASTM A 653/A653M – 05, Standard Specification for Steel Sheet, Zinc-Coated (Galvanized) or Zinc-Iron Alloy-Coated (Galvannealed) by the Hot-Dip Process
3	7.2.3.1(b), 7.2.3.1(c)(2)	ASTM B 555 – 86 (R2002), Standard Guide for Measurement of Electrodeposited Metallic Coating Thickness By the Dropping Test	No Equivalent	ASTM B 555 – 86 (R2002), Standard Guide for Measurement of Electrodeposited Metallic Coating Thickness By the Dropping Test
4	8.8.2.3.4(c)	ASTM D 1654 – 92 (R2000), Standard Test Method for Evaluation of Painted or Coated Specimens Subjected to Corrosive Environments	NMX-J-235/2-ANCE, Enclosures for Electrical Equipment, Environmental Considerations	ASTM D 1654 – 92 (R2000), Standard Test Method for Evaluation of Painted or Coated Specimens Subjected to Corrosive Environments
5	Table 6	ASTM D 714-02, Standard Test Method for Evaluating Degree of Blistering of Paints	NMX-J-235/2-ANCE, Enclosures for Electrical Equipment, Environmental Considerations	ASTM D 714-02, Standard Test Method for Evaluating Degree of Blistering of Paints
6	4.2	CAN/CSA C22.2 No. 0 – M91 (R2006), General Requirements – Canadian Electrical Code, Part II; C22.2 No. 0.4 – 04, Bonding of Electrical Equipment; C22.2 No 0.5 –82 (R2003), Threaded Conduit Entries	No Equivalent	No Equivalent
7	7.2.3.1(d)	No Equivalent	No Equivalent	Organic Coatings for Steel Enclosures for Outdoor Use Electrical Equipment, UL 1332
8	D.1.3.4(c)	CAN/CSA C22.2 No. 0.17 -00 (R2004), Evaluation of Properties of Polymeric Materials	NMX-J-565/3-ANCE, Flammability of Plastic Materials for Parts in Devices and Appliances	Tests for Flammability of Plastic Materials for Parts in Devices and Appliances, UL 94
9	D.1.2.1	ASTM D 570, Standard Test Method for Water Absorption of Plastics ASTM D 1042, Standard Test Method for Linear Dimensional Changes of Plastics under Accelerated Service Condition	No Equivalent	Polymeric Materials– Short Term Property Evaluations, UL 746A

**UL COPYRIGHTED MATERIAL –  
NOT AUTHORIZED FOR FURTHER REPRODUCTION OR  
DISTRIBUTION WITHOUT PERMISSION FROM UL**

Table Continued on Next Page

**Table Continued**

<b>Ref. No.</b>	<b>Clause No.</b>	<b>Canada</b>	<b>Mexico</b>	<b>United States</b>
10	1.2 and 7.3.4.1	CSA C22.2 No. 94.1, Standard for Enclosures for Electrical Equipment, non- environmental considerations	NMX-J-235/1, Standard for Enclosures for Electrical Equipment, non- environmental considerations	Standard for Enclosures for Electrical Equipment, non-environmental considerations, UL 50

***UL COPYRIGHTED MATERIAL –  
NOT AUTHORIZED FOR FURTHER REPRODUCTION OR  
DISTRIBUTION WITHOUT PERMISSION FROM UL***

**Annex C – Permanence Of Marking**  
(Normative In The United States Only)

C.1 A required marking shall be molded, die-stamped, ink-stamped, paint-stenciled; stamped or etched metal that is permanently secured; or indelibly applied lettering on a label secured by adhesive that, upon investigation, is found to be acceptable for the application. Ordinary usage, including likely exposure to weather and other ambient conditions, handling, storage, and the like, of the equipment shall be considered in the determination of the acceptability of the application. The need for exposure tests on forms of marking other than labels shall be individually evaluated.

C.2 After being subjected to the tests specified in Table C.1, the sample is to rest, dry, or cool, as applicable, for the period of time specified for the test involved. Subsequently, the labels shall show no separation from the test surface other than at the corners or edges. The total area of separation at the corners or edges shall not exceed 10 percent of the label area. The marking shall be legible.

**Table C.1**  
**Label performance criteria**

Enclosure type number	Inside the enclosure	Outside the enclosure
1	B	B
2, 5	B	A
3, 3R, 3S, 4	A	C
4X, 6, 6P	A	D
12, 12K, 13	B	A
<p>The requirement and qualification tests from the Standard for Marking and Labeling Systems, UL 969, are as follows (applies to nonmetallic labels and labels secured by adhesive.):</p> <p>A Exposure conditions for labels for use indoors where exposed to high humidity or occasional exposure to water.</p> <p>B Exposure conditions for labels intended only for indoor dry locations.</p> <p>C Exposure conditions for labels intended for both indoor or outdoor use where exposed to high humidity or occasional exposure to water.</p> <p>D Additional exposure conditions for labels depending on application.</p>		

C.3 For the purpose of the aging test conducted as part of the exposure conditions required in the Standard for Marking and Labeling Systems, UL 969, rated surface temperatures are considered to be those specified in Table C.2, except as follows:

A rated surface temperature other than those specified in Table C.2 may be used for the purposes of the aging test if it can be demonstrated that the temperature will not be exceeded in service.

**Table C.2**  
**Rated surface temperatures**

	<b>Indoor use</b>	<b>Outdoor use</b>
High Temperature	60° C (140° F)	80° C (176° F)
Low Temperature	0° C (32° F)	minus 35° C (minus 31° F)

## Annex D – Water Immersion Test (Normative)

### D.1 Water Exposure and Immersion

#### D.1.1 General

D.1.1.1 A polymeric material used for the enclosure of electrical equipment intended for outdoor installation shall not be appreciably degraded because of exposure to water. The acceptability of the material's resistance to such degradation may be judged by the procedure described in D.1.2, D.1.3.1, and D.1.3.2.

D.1.1.2 Table D.1 summarizes the minimum property retention limitations after exposure to water. The flammability classification of base samples of the material in the thinnest part thickness, and any color under consideration, shall not be reduced as a result of the 7 day at 70° C (158°F) conditioning described in D.1.3. The average physical-property values after the water exposure and immersion conditioning shall not be less than 50 percent of the original (non-water conditioned) value when the standardized small-scale physical test in Table D.1 are performed.

**Table D.1**  
**Minimum property retention limitations after water immersion conditioning**

Property	Water immersion <sup>a</sup>
Flammability Classification	Unchanged
Tensile or Flexural Strength <sup>b</sup>	50 percent
Tensile, Izod or Charpy Impact <sup>b</sup>	50 percent
<sup>a</sup> 7 days at 70°C <sup>b</sup> For functional support, the test methods are tensile strength and flexural strength. For impact resistance, the test methods are Tensile, Izod, or Charpy impact.	

#### D.1.2 Dimensional change

D.1.2.1 If a material exhibits a dimensional change greater than 2.0 percent after immersion for 168 hours in distilled water, as described in Annex B, Ref. No. 9, end-product tests are to be performed to determine if the change in dimension created by the service environment might cause:

- a) A reduction of spacings leading to excessive leakage currents;
- b) A dielectric breakdown after such exposure; or
- c) Warpage or swelling that might impair the acceptable operation of the equipment.



### D.1.3 Water exposure and immersion test

D.1.3.1 Using standard test procedures, property values for the material are to be determined both before and after the conditioning in D.1.3.2.

D.1.3.2 Specimens of the material shall be immersed in distilled or deionized water at  $70.0 \pm 1.0^\circ\text{C}$  ( $158.0 \pm 1.8^\circ\text{F}$ ) for 7 days. A complete change of water is to be made on each of the first 5 days. Following the water conditioning, those specimens that are to be subjected to physical-property tests are to be immersed in distilled or deionized water at  $23.0 \pm 2.0^\circ\text{C}$  ( $73.4 \pm 3.6^\circ\text{F}$ ) for 1/2 hour immediately prior to testing. Following the immersions, those specimens to be subjected to flammability tests are to be conditioned in air at  $23.0 \pm 2.0^\circ\text{C}$  ( $73.4 \pm 3.6^\circ\text{F}$ ) and  $50 \pm 5$  percent relative humidity for 2 weeks. Physical property tests conducted on the 3.2 mm (1/8 inch) thick specimens are considered representative of other thicknesses, down to 1.6 mm (1/16 inch).

D.1.3.3 For materials classed 5VA or 5VB or materials that are evaluated by Enclosure Flammability – 5 inch flame test (see Annex B, Ref. No. 1), the specimens shall be immersed in distilled or deionized water at  $82 \pm 1^\circ\text{C}$  ( $180 \pm 1.8^\circ\text{F}$ ) rather than  $70 \pm 1^\circ\text{C}$ .

D.1.3.4 The following properties shall be included in the evaluation (See Table D.2):

- a) For Functional Support, either
  - 1) Tensile Strength; or
  - 2) Flexural Strength.
- b) For Impact Resistance, either
  - 1) Tensile Impact;
  - 2) Izod Impact; or
  - 3) Charpy Impact.
- c) Flammability, as described in Annex B, Ref. No. 8. See Table D.2.

**Table D.2**  
**Physical-property test methods**

<b>Physical-property consideration</b>	<b>Material test method</b>
Functional support	Tensile strength or Flexural strength
Impact resistance	Tensile impact, Izod impact, or Charpy impact

D.1.3.5 Tensile strength tests conducted on 3.2 mm (1/8 inch nominal) or 4.0 mm thick specimens are considered representative of other thicknesses, down to 0.8 mm (1/32 inch).