

## Reference Design

# *AMC7150 – 1.5A Power LED Driver*

### *Content*

1. AMC7150 EVM User Guide
2. Application of AMC7150 @  $V_{IN}=12V_{DC}$
3. Application of AMC7150 @  $V_{IN}=24V_{DC}$
4. Application of AMC7150 for MR16
5. PWM Dimming Function of AMC7150
6. Thermal Issue of AMC7150: Temperature vs. Current
7. Relationship between  $V_{IN}$  and the LED Driving Current

# 1. AMC7150 EVM User Guide

## 1.1. Circuit Scheme:

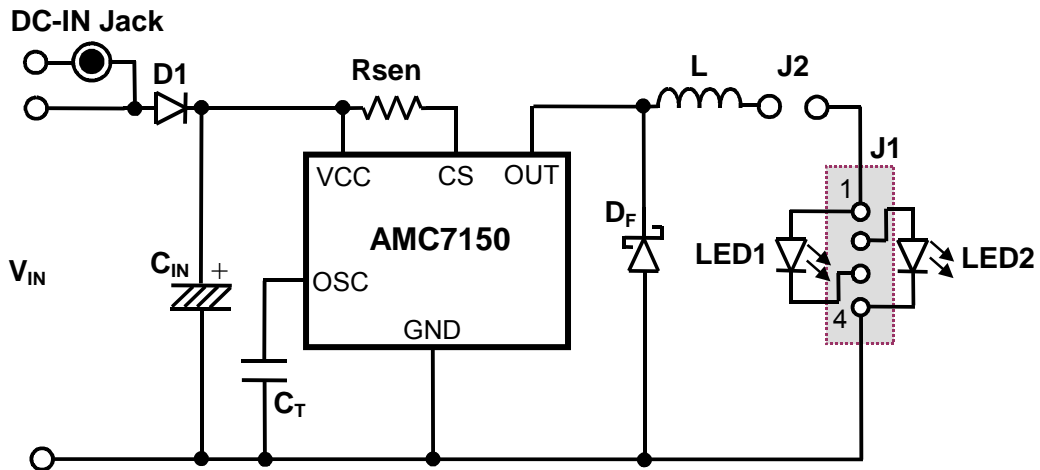

## 1.2. Picture:

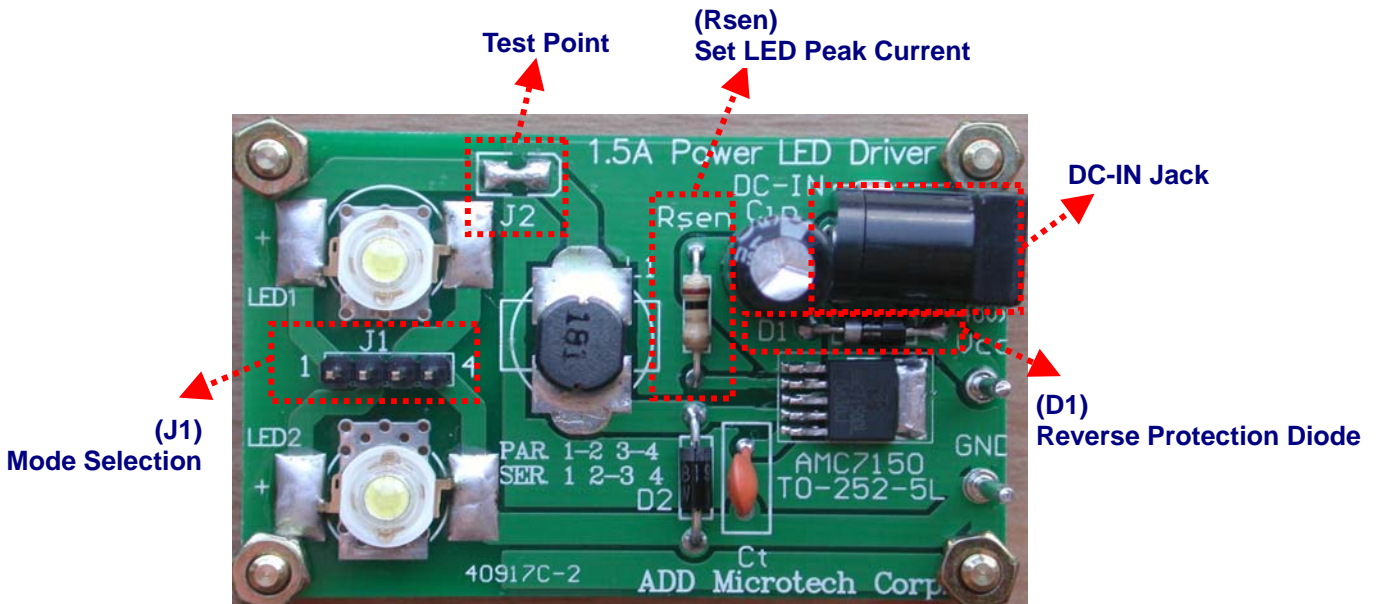

### 1.3. Description:

- 【1】 **DC-IN:** DC power jack. It is designed to provide convenience for demo. Simply one adapter is needed for supplying the EVM board to light up the Power LEDs.
- 【2】 **D1:** Reverse protection diode. It is located between input port of the EVM,  $V_{IN}$ , and  $V_{CC}$  pin of the IC. The function is to provide protection when input source is reverse connected.
- 【3】 **J1:** Lighting mode selection connector. Four lighting modes of the 2 LEDs can be accomplished through jumper. The 2 LEDs can be connected in series or parallel, or either of the 2 LEDs can be selected. The method of selecting one of these modes is shown in the following table.

Table Method of using jumper to select 1 of the 4 lighting modes for the 2 LEDs.

Mode	Lighting condition of LED1 and LED2	J1
1	LED1&LED2 connected in serial	1 <span style="border: 1px solid black; padding: 2px;">2 3</span> 4
2	LED1&LED2 connected in parallel	<span style="border: 1px solid black; padding: 2px;">1 2</span> <span style="border: 1px solid black; padding: 2px;">3 4</span>
3	LED1	1 2 <span style="border: 1px solid black; padding: 2px;">3 4</span>
4	LED2	<span style="border: 1px solid black; padding: 2px;">1 2</span> 3 4

- 【4】 **J2:** Test point. It is reserved for current measurement to make sure that the LED driving current matches the value calculated by the formula below (Please refer to the datasheet for the calculated method of the average current):

$$I_{PK} = \frac{330mV \pm 10\%}{R_{sense}}$$

### 1.4. Reference PCB Layout:

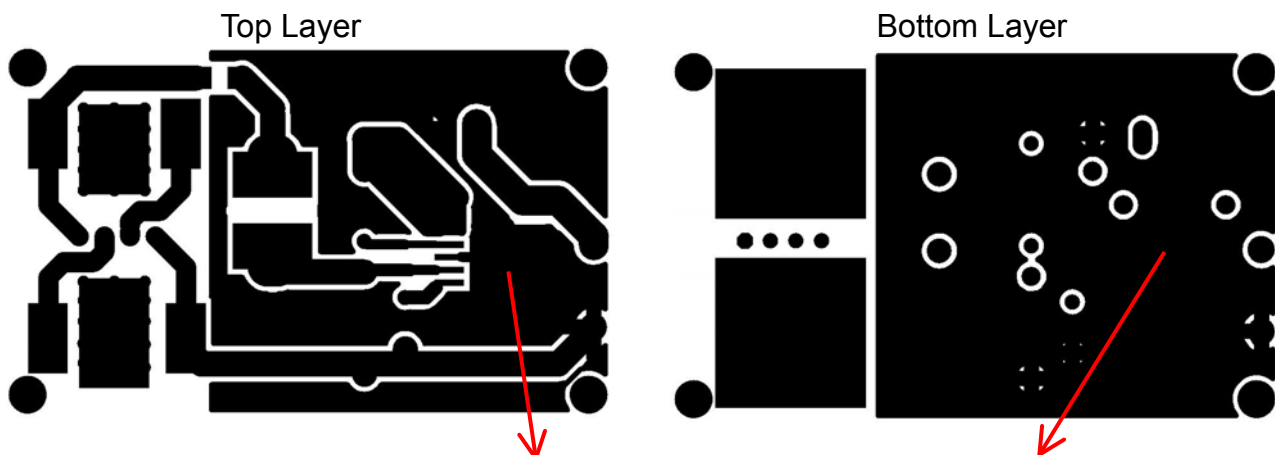

Large PCB area is reserved for GND plane and is connected to the heat pad of AMC7150. The GND plane can be a part of heat sink for AMC7150.

## 2. Application of AMC7150 @ $V_{IN}=12V_{DC}$

### 2.1. $V_{IN}=12V_{DC}$ for 1pcs of Power LED:

#### A. Circuit Diagram:

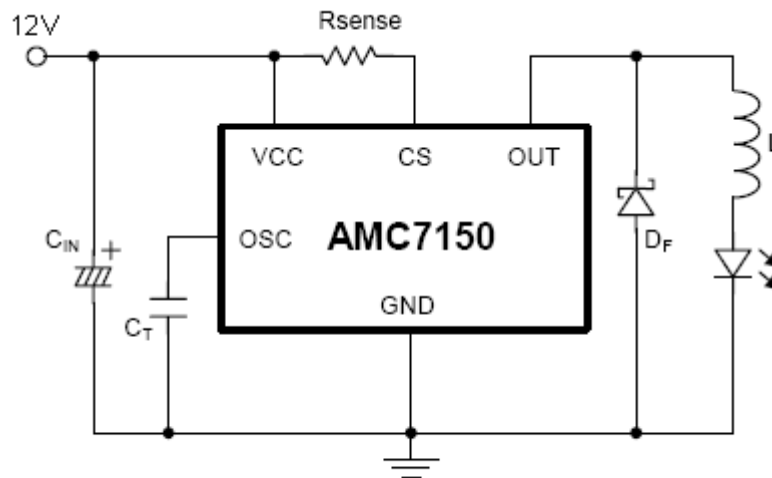

#### B. Bill of Material:

Component	Value	Package
AMC7150	-	TO-252-5L
$C_{IN}$	47uF / 16V	E. C. Cap.
$C_T$	680~820pF	DIP / SMD 0603
$R_{SENSE}$	0.87 $\Omega$	DIP / SMD 1206
$D_F$	1N5819	DO-41 (Axial Lead)
L	220uH	-

## 2.2. $V_{IN}=12V_{DC}$ for 2pcs of Power LED in Series:

### A. Circuit Diagram:

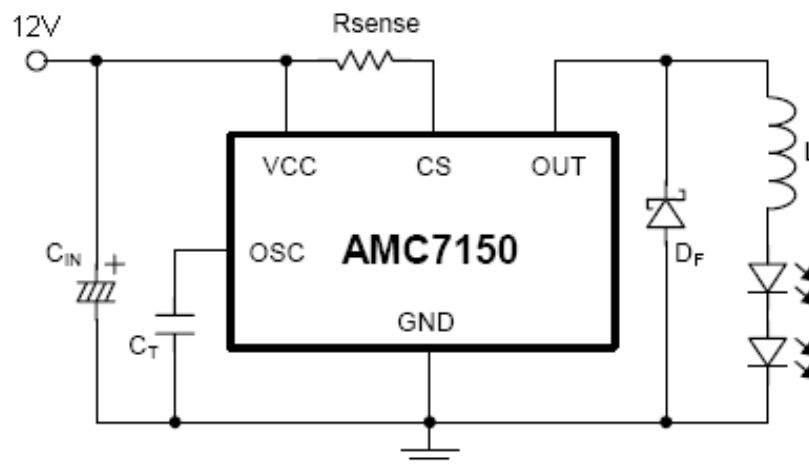

### B. Bill of Material:

Component	Value	Package
AMC7150	-	TO-252-5L
$C_{IN}$	47 $\mu$ F / 16V	E. C. Cap.
$C_T$	680~820pF	DIP / SMD 0603
$R_{SENSE}$	0.83 $\Omega$	DIP / SMD 1206
$D_F$	1N5819	DO-41 (Axial Lead)
L	220 $\mu$ H	-

### 2.3. $V_{IN}=12V_{DC}$ for 3pcs of Power LED in Parallel:

#### A. Circuit Diagram:

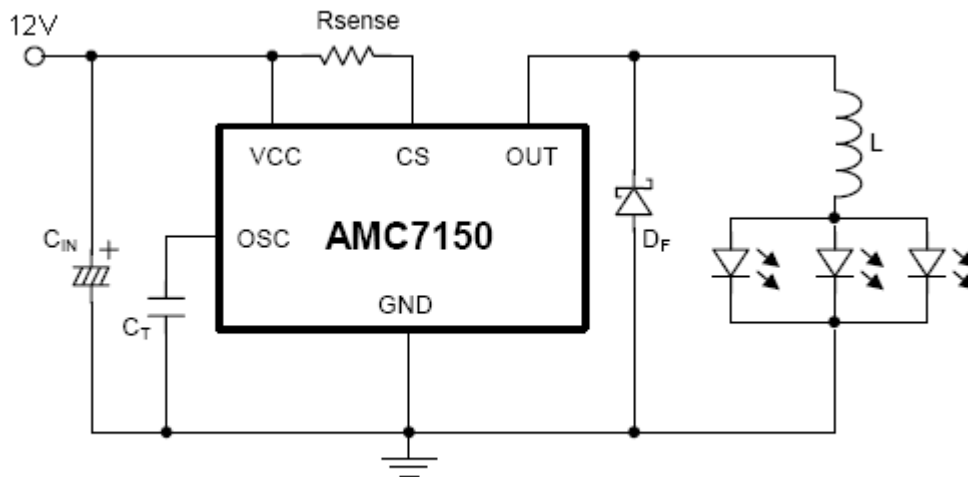

#### B. Bill of Material:

Component	Value	Package
AMC7150	-	TO-252-5L
$C_{IN}$	47uF / 16V	E. C. Cap.
$C_T$	680~820pF	DIP / SMD 0603
$R_{SENSE}$	0.92 $\Omega$	DIP / SMD 1206
$D_F$	1N5819	DO-41 (Axial Lead)
L	220uH	-

### 3. Application of AMC7150 @ $V_{IN}=24V_{DC}$

#### 3.1. $V_{IN}=24V_{DC}$ for 2pcs of Power LED in Series:

##### A. Circuit Diagram:

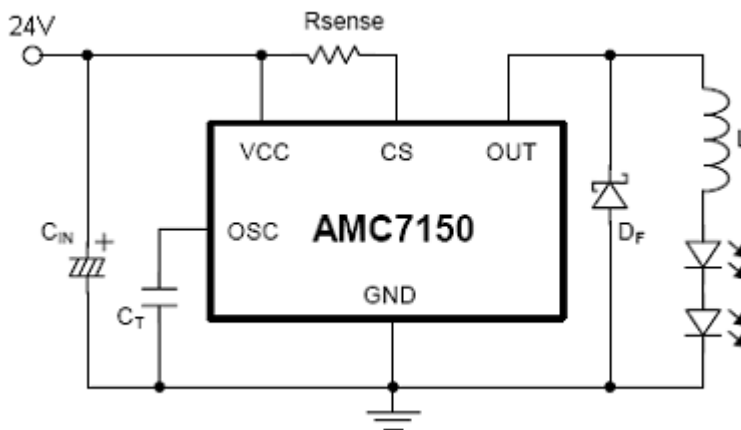

##### B. Bill of Material:

Component	Value	Package
AMC7150	-	TO-252-5L
$C_{IN}$	47uF / 35V	E. C. Cap.
$C_T$	680~820pF	DIP / SMD 0603
$R_{SENSE}$	0.83 $\Omega$	DIP / SMD 1206
$D_F$	1N5819	DO-41 (Axial Lead)
L	220uH	-

### 3.2 $V_{IN}=24V_{DC}$ for 3pcs of Power LED in Series:

#### A. Circuit Diagram:

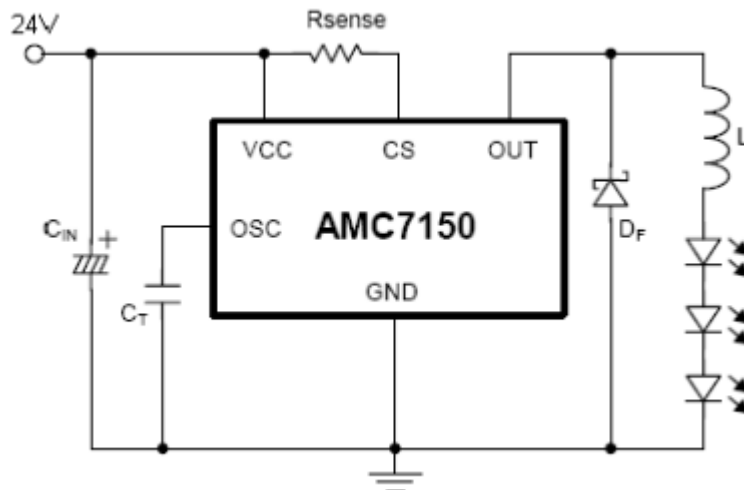

#### B. Bill of Material:

Component	Value	Package
AMC7150	-	TO-252-5L
$C_{IN}$	47uF / 35V	E. C. Cap.
$C_T$	680~820pF	DIP / SMD 0603
$R_{SENSE}$	0.8 $\Omega$	DIP / SMD 1206
$D_F$	1N5819	DO-41 (Axial Lead)
L	220uH	-



## 4. Application of AMC7150 for MR16

### 4.1. Application Circuit of AMC7150 for MR16 ( $V_{IN}=12V_{AC}$ ):

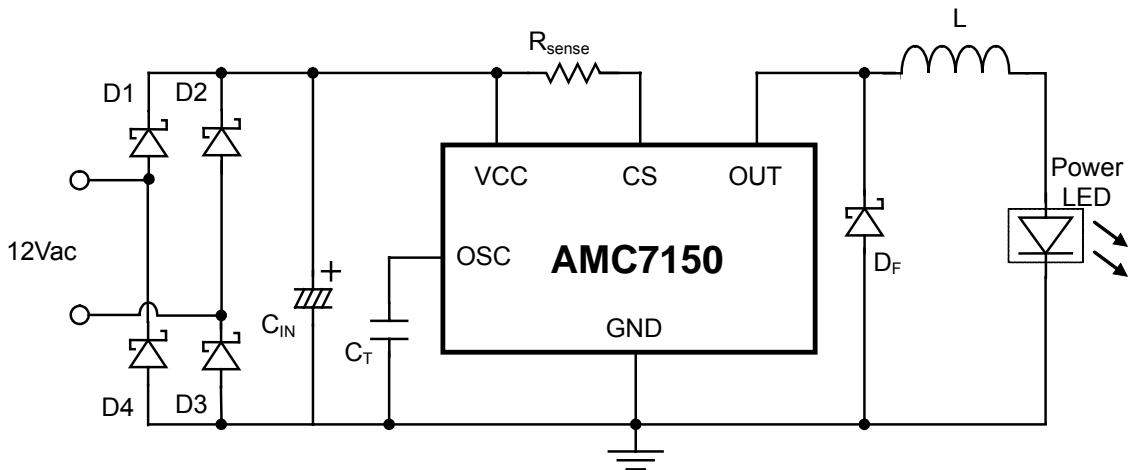

### 4.2. Bill of Material:

C. R. No.	Q'TY	Value	Description
PCB	1	-	PCB – 12V Ballast Solution 7150 for MR-16
IC	1	-	AMC7150
$C_{IN}$	1	47~100uF/25V	Tantalum Chip Cap.
D1~D4	4	FM140-M	Schottky Diode 【40V/2A】
$D_F$	1	FM140-M	Schottky Diode 【40V/2A】
$R_{SENSE}$	1	0.22Ω~3Ω	SMD 0603
L1	1	220uH	$I_{DC}=0.4 \sim 1.2A$
$C_T$	1	680~820pF	SMD 0603

## 5. PWM Dimming Function of AMC7150

### 5.1 Application Circuit :

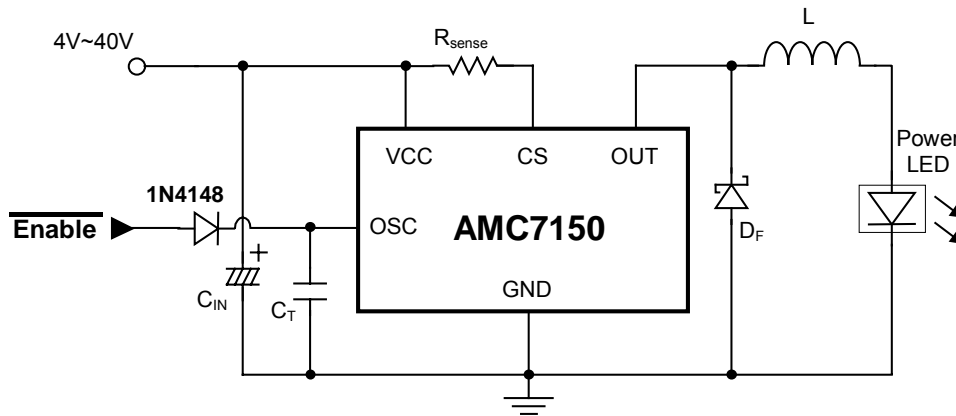

### 5.2 Description of Enable Control :

One diode (1N4148) is added between the inward PWM control signal and the OSC pin.

Parameter	Description	Symbol	Min	Max	Unit	Apply Pin
Enable voltage "High"	Turn OFF the driver	$V_{\overline{EN},H}$	2	5.5	V	$\overline{\text{Enable}}$
Enable voltage "Low"	Turn ON the driver	$V_{\overline{EN},L}$		0.4	V	
Enable voltage sink current	Turn OFF the driver	$I_{\overline{EN}}$		300	uA	

### 5.3 Measured Waveform :

When ON duty=100%,  $i_{LED,Mean} = 369\text{mA}$

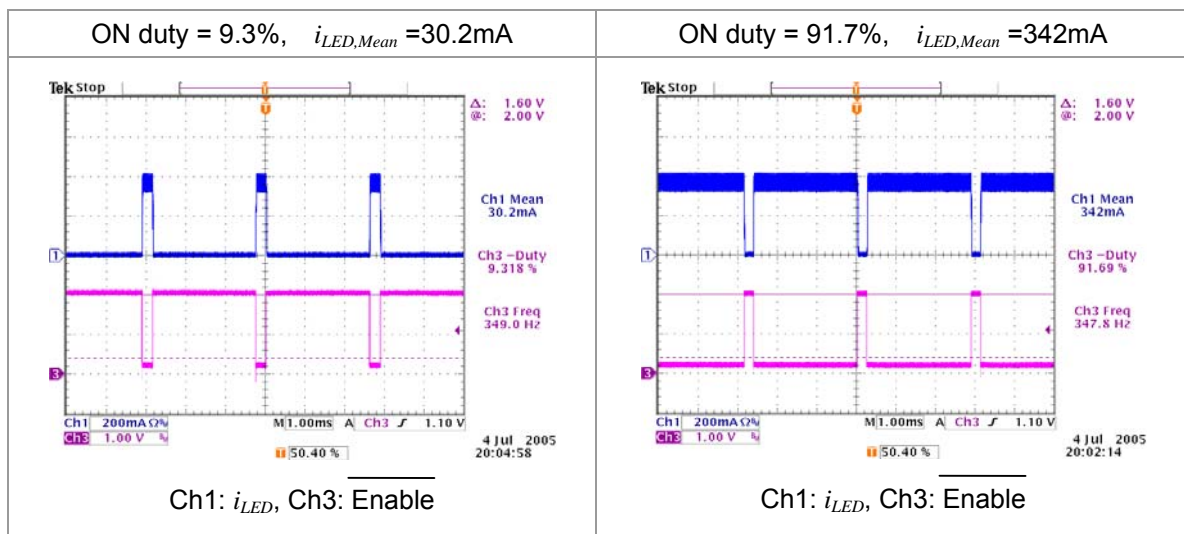

## 6. Thermal Issue of AMC7150: Temperature vs. Current

AMC7150 can work well under ambient temperature from  $-40^{\circ}\text{C}$  to  $+125^{\circ}\text{C}$ . Put the AMC7150 EVM board into the programmable chamber to simulate the extreme temperature environment, the AMC7150 EVM board can work well, as the measured waveforms of LED current and the oscillating waveform of  $C_T$  shown in the following table:

Table AMC7150 EVM can work well under ambient temperature from  $-40^{\circ}\text{C}$  to  $+125^{\circ}\text{C}$ .

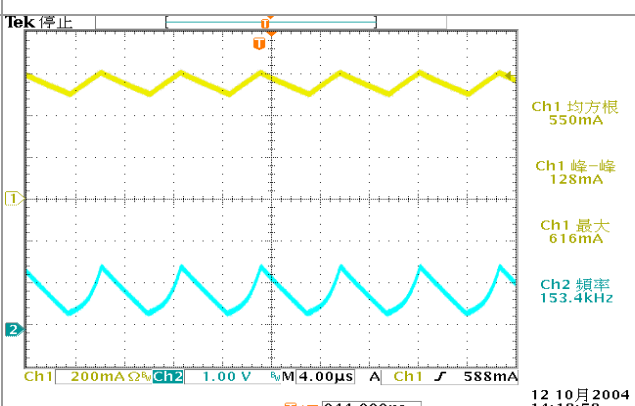
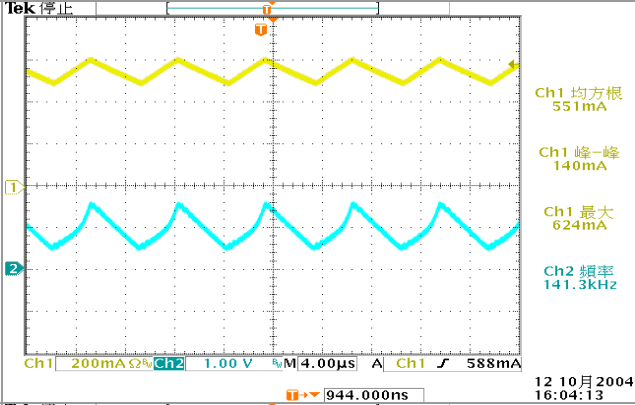
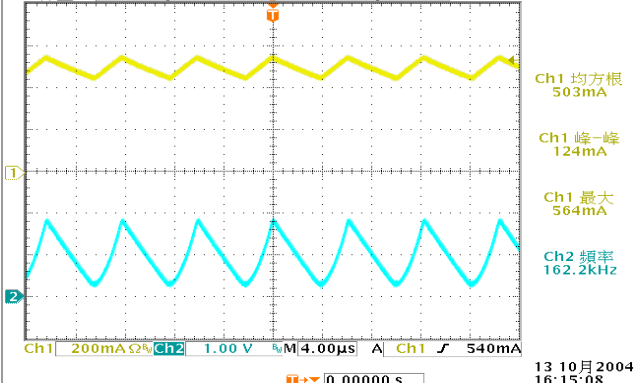
Ambient Temperature	Measured waveforms	Test condition
Room Temperature	 <p>Ch1 均方根 550mA Ch1 峰-峰 128mA Ch1 最大 616mA Ch2 頻率 153.4kHz</p> <p>Ch1 200mA/Ω Ch2 1.00V 4.00μs A Ch1 588mA</p> <p>12 10月2004 14:18:58</p>	CH1 : $i_L$ CH2 : $C_T$ $V_{cc}=12\text{V}$ $R_{sen}=0.5\Omega$ $L=180\mu\text{H}$ $\text{LED}=1\text{pcs}$ $C_T=820\text{pF}$ $V_{f,\text{LED}}=3.34\text{V}$
Low Temperature $-40^{\circ}\text{C}$	 <p>Ch1 均方根 551mA Ch1 峰-峰 140mA Ch1 最大 624mA Ch2 頻率 141.3kHz</p> <p>Ch1 200mA/Ω Ch2 1.00V 4.00μs A Ch1 588mA</p> <p>12 10月2004 16:04:13</p>	CH1 : $i_L$ CH2 : $C_T$ $V_{cc}=12\text{V}$ $R_{sen}=0.5\Omega$ $L=180\mu\text{H}$ $\text{LED}=1\text{pcs}$ $C_T=820\text{pF}$ $V_{f,\text{LED}}=3.626\text{V}$
High Temperature $+125^{\circ}\text{C}$	 <p>Ch1 均方根 503mA Ch1 峰-峰 124mA Ch1 最大 564mA Ch2 頻率 162.2kHz</p> <p>Ch1 200mA/Ω Ch2 1.00V 4.00μs A Ch1 540mA</p> <p>13 10月2004 16:15:08</p>	CH1 : $i_L$ CH2 : $C_T$ $V_{cc}=12\text{V}$ $R_{sen}=0.5\Omega$ $L=180\mu\text{H}$ $\text{LED}=1\text{pcs}$ $C_T=820\text{pF}$ $V_{f,\text{LED}}=3.2\text{V}$

## 7. Relationship between $V_{IN}$ and the LED Driving Current

When  $V_{IN}$  changes, the RMS value of LED driving current will change slightly.

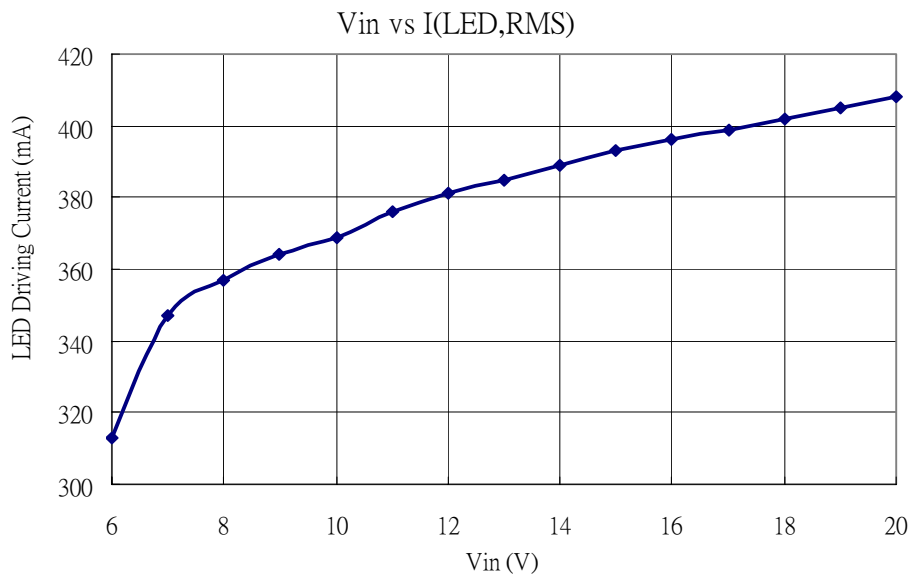

<b><math>V_{IN}=8\sim 12V</math></b>	$\frac{di}{dv} = \frac{381\text{ mA} - 357\text{ mA}}{12V - 8V} = 6\text{ mA}/V$ $\% / V = \frac{6\text{ mA}/V}{381\text{ mA}} = 1.57\% / V$
<b><math>V_{IN}=12\sim 16V</math></b>	$\frac{di}{dv} = \frac{396\text{ mA} - 381\text{ mA}}{16V - 12V} = 3.75\text{ mA}/V$ $\% / V = \frac{3.75\text{ mA}/V}{381\text{ mA}} = 0.98\% / V$